



**US Army Corps  
of Engineers**  
Huntsville Division

---

# **A History of Huntsville Division**

**U.S. Army  
Corps of Engineers**

**1982-1987**



# Report Documentation Page

Form Approved  
OMB No. 0704-0188

Public reporting burden for the collection of information is estimated to average 1 hour per response, including the time for reviewing instructions, searching existing data sources, gathering and maintaining the data needed, and completing and reviewing the collection of information. Send comments regarding this burden estimate or any other aspect of this collection of information, including suggestions for reducing this burden, to Washington Headquarters Services, Directorate for Information Operations and Reports, 1215 Jefferson Davis Highway, Suite 1204, Arlington VA 22202-4302. Respondents should be aware that notwithstanding any other provision of law, no person shall be subject to a penalty for failing to comply with a collection of information if it does not display a currently valid OMB control number.

1. REPORT DATE <b>1990</b>		2. REPORT TYPE		3. DATES COVERED <b>00-00-1990 to 00-00-1990</b>	
4. TITLE AND SUBTITLE <b>A History of the Huntsville Division U.S. Army Corps of Engineers 1982-1987 Update</b>				5a. CONTRACT NUMBER	
				5b. GRANT NUMBER	
				5c. PROGRAM ELEMENT NUMBER	
6. AUTHOR(S)				5d. PROJECT NUMBER	
				5e. TASK NUMBER	
				5f. WORK UNIT NUMBER	
7. PERFORMING ORGANIZATION NAME(S) AND ADDRESS(ES) <b>U.S. Army Corps of Engineers,Huntsville Division,PO Box 1600,Huntsville,AL,35807</b>				8. PERFORMING ORGANIZATION REPORT NUMBER	
9. SPONSORING/MONITORING AGENCY NAME(S) AND ADDRESS(ES)				10. SPONSOR/MONITOR'S ACRONYM(S)	
				11. SPONSOR/MONITOR'S REPORT NUMBER(S)	
12. DISTRIBUTION/AVAILABILITY STATEMENT <b>Approved for public release; distribution unlimited</b>					
13. SUPPLEMENTARY NOTES					
14. ABSTRACT					
15. SUBJECT TERMS					
16. SECURITY CLASSIFICATION OF:			17. LIMITATION OF ABSTRACT	18. NUMBER OF PAGES	19a. NAME OF RESPONSIBLE PERSON
a. REPORT <b>unclassified</b>	b. ABSTRACT <b>unclassified</b>	c. THIS PAGE <b>unclassified</b>			

**A HISTORY OF  
HUNTSVILLE DIVISION  
U.S. ARMY  
CORPS OF ENGINEERS**

**1982-1987 UPDATE**

**Contract No. DACW87-88-C-0042**

**by**

**Louis Torres**

**1990**

# Table Of Contents

<b>FOREWORD</b>	<b>iii</b>
<b>PREFACE</b>	<b>iv</b>
<b>ACKNOWLEDGEMENTS</b>	<b>v</b>
<b>I EVOLUTION OF THE MISSION: FROM ONE MISSION TO MANY</b>	<b>1-1</b>
<b>II THE DIVISION'S RESOURCES</b>	<b>2-1</b>
<b>III ADVANCED TECHNOLOGY IN DEFENSE AREAS OF NATIONAL SIGNIFICANCE</b>	<b>3-1</b>
<b>IV HIGH TECHNOLOGY FACILITY SUPPORT</b>	<b>4-1</b>
<b>V MAJOR PROCUREMENT MISSIONS</b>	<b>5-1</b>
<b>VI CORPS TRAINING AND TRAINING MANAGEMENT</b>	<b>6-1</b>
<b>VII CONCLUSION</b>	<b>7-1</b>
<b>NOTES</b>	<b>Notes-1</b>
<b>APPENDIX</b>	<b>A-1</b>
<b>BIBLIOGRAPHY</b>	<b>B-1</b>

# Foreword

The update history of Huntsville Division tells the story of an organization whose responsibilities, according to its charter, are to serve the Corps of Engineers and its customers in areas of complex contracting, training, and high engineering technology. Organized without a boundary and districts to administer, Huntsville Division is unique within the Corps. This uniqueness made it possible for the Division to cut across all Corps boundaries and agencies for the benefit of the Military Establishment and the country. The number of Centers of Expertise which Headquarters, U.S. Army Corps of Engineers has seen appropriate to assign to Huntsville Division during the period of this history is testimony to the trust that headquarters has placed upon the Division. Much is owed to the men and women of the Division who have made this success possible, and I take this opportunity to dedicate this history to them.

**PHILIP L. HALL**  
**Colonel, Corps of Engineers**  
**Commanding**

## Preface

The preparation of this history update of Huntsville Division was the result of Contract Number DACW87-88-C-0042 awarded 12 May 1988. In abiding by the conditions of the contract, the author has attempted to write a history that establishes continuity with the past, provides some description of the technical subject matter to the layman, and, above all, provides the reader with an understanding of the problems inherent in the accomplishment of a highly technical mission. Yet despite those problems, Huntsville Division accomplished its mission effectively. The uniqueness of Huntsville Division, which sets it apart from other Corps agencies, should provide the reader with more than just a casual interest in the history of this organization.

The author's graduate work was completed at Columbia University. He served 32 years as a government historian, half of them with the Departments of the Army and Air Force, and the other half with the National Park Service. He is now retired from government service and works as a historical consultant. He is the author of books and articles on local history and national historic sites. More recently, he prepared two publications for the Corps of Engineers: one, published by the Government Printing Office, is titled "To the Immortal Name and Memory of George Washington: The United States Army Corps of Engineers and the Construction of the Washington Monument." The other is titled "A History of the U.S. Army Construction Engineering Research Laboratory, 1964-1985."

# Acknowledgements

The author wishes to express his gratitude to the following former and present members of Huntsville Division who provided him with a wealth of data so that he could write this history: Colonel Charles T. Myers III, the late Colonel John A. Poteat, Colonel Rudolph E. Abbott, Colonel Robert S. Lindsay, Colonel William A. Miller, Lieutenant Colonel John C. McIlrath, Lieutenant Colonel Leon W. Cook, Mr. Walter R. Peterson, Mr. James A. Henderson, Mr. Raymond D. Aldridge, Mr. Emmett N. Creekmore, and Mr. Gerald D. Dupree. The author is also grateful to the following persons in HQUSACE for granting him interviews: Messrs. Ralph Loschialpo, John Reimer, Gerald Liebes, Jim Vincent, and Charles Dunnam. A word of thanks must also go collectively to the Historical Committee for its guidance and assistance in reviewing each chapter of the draft. Finally, without the administrative assistance of the following persons, to which the author owes a special debt of gratitude, the history would have been difficult, if not impossible, to prepare: Ms. Jimmie L. Davis, Mr. Ken Crawford, Ms. Judy M. Wilson, Ms. Therese S. Odom, Ms. Janice J. Perry, and Mr. Daniel F. Talbot.

## Historical Committee

**1988--1990**

**Chairperson (1988) Jimmie Davis, Administrative Officer**  
**Chairperson (1989-90) Ken Crawford, Chief, Public Affairs**  
**Jack Bowen, Information Management Office**  
**Gerald Dupree, Resource Management Office**  
**Jim Hudson, Engineering Division**  
**Susan Jackson, Contracting Division**  
**Elnora Johnson, Information Management Office**  
**Debbie Jones, Contracting Division**  
**Ron Larkin, Contracting Division**  
**Betty Neff, Engineering Division**  
**Jeff Seward, Training Division**  
**Judy Wilson, Public Affairs Office**

# Evolution of the Mission: From One Mission to Many

## In Retrospect

Unique from the moment of its conception, Huntsville Division was founded in order to serve a single mission. Yet this Division has since developed into a diverse organization with a central role in Corps-wide programs. In October 1967, in response to a national policy to deploy a ballistic missile defense system, Huntsville Division was established as a separate Class II activity under the command of the Chief of Engineers. The sole mission of this Division was to manage the design and construction of facilities needed for the Army's SENTINEL/SAFEGUARD Ballistic Missile Defense (BMD) System and the Division's only customer, the Sentinel System Command.<sup>1</sup> Unlike other Corps divisions, this new division had no districts under it, no military engineering functions other than the one assigned, no civil works responsibilities, and no geographic boundaries. These special characteristics have made Huntsville Division an operational and functional organization unmatched within the Corps.

With the change in national policy of the BMD mission in 1972, Division work load shifted from a single-purpose mission to a multipurpose and diversified mission. At first the change was gradual, but before long the Division became the recipient of several high technology projects. Headquarters, United States Army Corps of Engineers (HQUSACE) recognized the Division's talents and gave it new missions spanning geographic boundaries. Moreover, Headquarters concluded that the establishment of these new missions, some of which were mandated by national policy and Army regulation, were consistent with the Division's non-geographic and operational role. Assigning new missions also provided an opportunity to move certain functions out of the National Capital region to a field operating activity (FOA) without downgrading mission performance. This idea of decentralization was not new; other Government agencies had been undertaking similar measures. Another reason for assigning new missions was that the Corps, like other agencies, was required to use its resources to the

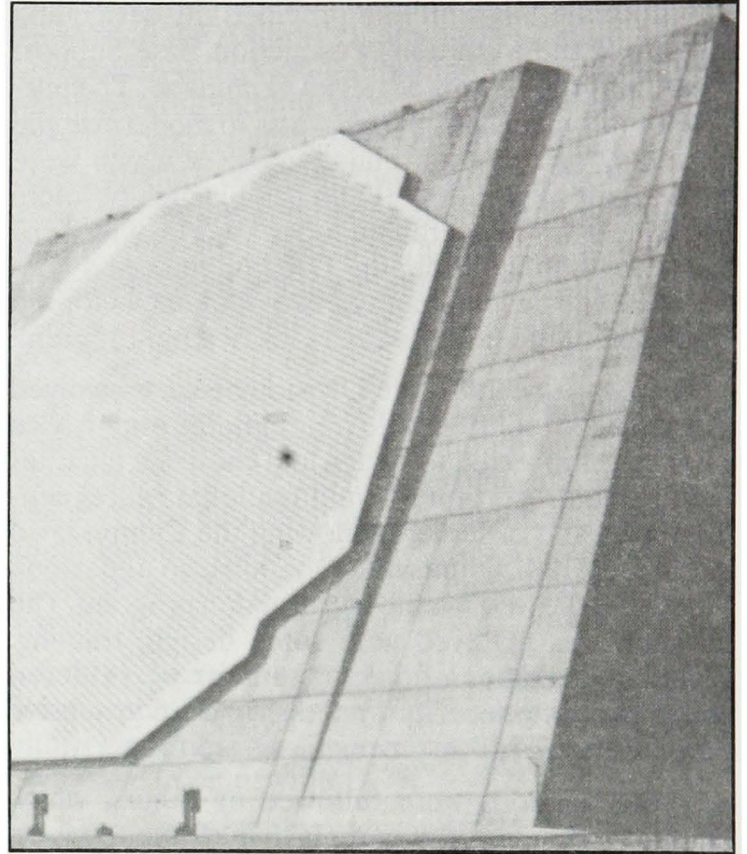

Ballistic Missile Defense

maximum possible extent; therefore, with the loss of the SAFEGUARD mission, Headquarters believed that the change in BMD policy was an excellent opportunity to place other missions upon the Division's shoulders.<sup>2</sup>

After several years in SENTINEL/SAFEGUARD work, Huntsville Division began to broaden its mission base. In 1978, HQUSACE assigned several operating missions and functions to the Division. Because of the Division's extensive experience with government-furnished property procurement in the BMD program, Huntsville Division was directed to procure fixed mechanical components for 21 Postal Service bulkmail sites. Later, the Division's broad procurement experience was applied to an ongoing effort in government-furnished property procurement for the government of Saudi Arabia, as well as Jordan's Armor Rebuild Center.

Other significant assignments during the late seventies further expanded Huntsville Division's versatility. The Division provided design engineering and construction for test facilities at the National Aeronautics Space Agency (NASA) Marshall Space Flight Center in Huntsville and the National Space Technology Laboratory near Bay St. Louis, Mississippi. Huntsville Division also provided the design and support of the Munitions Production Base Support Program for the Army Materiel Command. The purpose of this extensive program was to modernize the old Army ammunition plants, most of which were built during World War II and had become obsolete and dangerous to operate in today's world of modern technology. In addition, the Division managed contracts for the development of two pilot plants for the Department of Energy's Coal Gasification Program.

Then, in June 1981, the Division became involved in a project of considerable international importance when it was directed to design and construct facilities in the Sinai Desert for the multinational Peacekeeping Force and observers following the Camp David Accord. In 1981, Huntsville Division also undertook to support the MX missile construction program. The Division was involved with some design, training, systems engineering, management of selected programs, site security systems, and an extensive procurement of government-furnished property.

These missions were followed by others, which gradually changed the complexion of the Division from an agency with a single mission serving one customer to an organization performing a variety of design engineering, construction, procurement, and training functions for a wide spectrum of government agencies. Huntsville Division also continued to provide facility support to the Ballistic Missile Defense Command in its research on the Strategic Defense Initiative.

In addition to those missions already noted, the following were assigned to the Division between 1977 and 1981:

- Terrain Analysis
- Army Pollution Abatement Program
- Army Facilities Component Systems
- Design and Construction Evaluation
- Corps of Engineers Documentation Update
- Corps of Engineers Training and Training Management
- Army Force Modernization (New Army Systems)

- Defense Communications Systems (Facilities Design)
- Mobilization (Planning and Design) U.S. Army Commissary Stores
- Solid Fuel Conversion
- Railroad Improvement Program
- Lethal Chemical Munitions Demilitarization
- Defense Nuclear Agency Support
- Army Range Modernization
- Installation Restoration
- Computer-Aided Engineering and Architectural Design Systems
- Medical Facilities Design Services
- Energy Monitoring and Control Systems
- Energy Engineering Analysis Program
- Resource Conservation and Recovery Act.<sup>3</sup>

By the end of 1981, 13 years after its establishment, Huntsville Division remained an organization possessing several unique qualities. Although its mission was manifold, the Division had emerged as a specialized FOA of the Corps with capabilities in several functional areas.

## The Mission: 1982-1987

As the Division began 1982, it saw its role as supporting the Corps of Engineers in many of its new missions; providing support to other agencies where the Corps played a vital role; enhancing program relationships between Corps divisions, districts, and FOAs; and, most important, maintaining an effective and efficient organization to produce high quality products for the many Corps customers. The Division was convinced that because of its experience with sophisticated, unique, and highly technical programs, it could contribute immensely to future programs.<sup>4</sup>

This strong conviction was echoed by Colonel John A. Poteat, Division Commander, on the eve of his retirement in 1984. In writing to the Chief of Engineers, he said:

I believe it is vital for the success of the Corps to have a specialized advanced technology operating division like Huntsville to serve as an extension of the Office, Chief of Engineers staff for certain operating missions; to function as a central manager or one face

of the Corps in managing large geographically centralized programs for customers; to serve as a high technology center of expertise for a variety of missions for which it would be too difficult and expensive to provide the particular expertise to all FOAs; and finally, to take on execution of special rapid response, complex missions. It was certainly gratifying that the Command Strategy which was published last fall recognizes the role of Huntsville Division in this concept.<sup>5</sup>

The same message uttered by Colonel Poteat is condensed in a few words in the Division's Statement of Purpose printed on a plaque hanging in the hallway outside the Executive Office. The statement reads: "U.S. Army Engineer Division, Huntsville, Provides Management and Technical Services for Specialized Corps-wide Programs that are Broad in Scope, Technically Sophisticated or Require Rapid Response."

By 1982, support to the MX System was discontinued; however, the offensive missile phase-down created by treaties was compensated for by an increase in defensive missile systems, that is, in the Strategic Defense Initiative.<sup>6</sup> Other missions soon followed, and the Division grew significantly. By 1987, Huntsville Division's work load was nearly three times as much as it was in 1980.<sup>7</sup>

Some programs, especially those that were concerned with the environment, were sometimes impeded or entirely eliminated because of a reduction of funds or because of changes in national policies. However, Headquarters continued to recognize Huntsville Division's role in the Corps' total mission execution, thus allowing the Division to seek mission assignments within the parameters of its charter.<sup>8</sup>

In January 1982, the Division was given responsibilities in the Power Reliability Enhancement Program, more commonly referred to as Project PREP, and in February, it assumed facility support for the SENTRY Program in the areas of environmental assessment/environmental impact statements; developing programming documentation; master planning; site selection and coordination in real estate acquisition; facility design and construction; facility systems engineering; advanced procurement of materials and equipment; and special studies such as nuclear weapons effects, vulnerability, and hardness.<sup>9</sup>

In April, the Division was charged with the

management of subsurface investigations, groundwater assessments, and assistance in complying with the Resource Conservation and Recovery Act of 1976, a mission that was part of the Pollution Abatement Program. A mission to support the Army Toxic and Hazardous Materials Agency was also assigned that month. In April, Huntsville Division was designated the Assigned Responsible Agency for the Computer-Aided Cost Estimating System (CACES), which was the module of the Computer-Aided Engineering and Architectural Design System. An additional module was also incorporated into CACES called the Automatic Budget Estimating System. In August 1982, an interagency agreement was signed with the Federal Management Agency, allowing the Division to participate in the Keyworker Blast Shelter Program.<sup>10</sup>

In FY 1982, five revisions were made to the Division's organization and functions regulation. The regulation was altered to broaden its scope and to add a charter that described the programmatic and functional boundaries of the Division. The charter assigned programs, projects, and tasks that contained five common characteristics:

1. Programs that were national and broad in scope. For example, the Division was the key organization within the Corps to support the Strategic Defense Command in Huntsville.

2. Programs that required integrated facilities or systems that crossed division boundaries, such as the Production Base Support Program. The Division managed and provided technical support for the modernization and expansion of 26 Army ammunition production plants located throughout the United States.

3. Programs that required commonality, standardization, multiple site adaptation, or technology transfer. An example of this was the Army Facilities Components System (AFCS) where the Division provided planning guidance, construction drawings, and bills of materials needed for Army construction in a theater of operations. AFCS grew to the extent that the Division developed about 4,100 facility designs and 750 installation designs. Some of these designs included troop camps, hospitals, bridges, marine terminals, port facilities, and ammunition storage facilities.

4. Programs that required a centralized management structure for the effective control of program

development, coordination, and execution, such as the Production Base Support Program, government-furnished procurement programs, and others.

5. Programs that required the performance of functions that were normally executed by a headquarters organizational element. For example, Huntsville Division managed the training mission for the Corps of Engineers, a function previously performed by HQUSACE.<sup>11</sup>

Although the charter defined program characteristics, Huntsville Division's mission remained broad and complex. This mission was divided into two areas. One area contained a list of "continuous mission assignments" or programs with an indefinite lifetime. The other area contained a long list of "specialized mission assignments" that varied in number according to customer needs at any given time. Customers could be the Corps of Engineers, Army Materiel Command, Department of Defense, Department of the Army, Department of Energy, or any other federal agency. All missions and programs, which were described in individual tasking assignments, required the application of advanced engineering technology; program development and management; systems engineering; reliability, operational, and maintenance analyses; documentation; and the design and analysis of protective structures and systems for hardened facilities.<sup>13</sup>

In 1982, there were ten continuous mission assignments. By 1987, however, one had been eliminated, the mission which had made the Division responsible for the administration of the worldwide Design and Construction Evaluation Program for Military Programs. With the transfer of this mission back to HQUSACE, the following continuous missions remained:

1. To serve as the single point of contact for USACE in matters dealing with BMD facilities.
2. To be responsible for the overall administration and management of the Corps Short Course Training Program.
3. To provide support to and serve as the single USACE point of contact for NASA industrial-type activities.
4. To be responsible for conducting centralized procurement functions, as assigned, in complex procurement and contract administration of government-furnished property.

5. To manage and execute the design program for AFCS.

6. To serve as the support element responsible for Military Program Guidance USACE Documentation Update Program. This included the production, review, and maintenance of guide specifications and technical manuals as well as the operation and maintenance of the SPECBASE System and the Guide Specification Notification Program.

7. To provide overall technical, fiscal, and program management for the Production Base Support Construction Program. The Division designed facilities where the process systems were common to two or more sites, and produced designs requiring technical complexity or design commonality.

8. To serve as the Assigned Responsible Agent in implementing and maintaining assigned automated engineering and architectural systems such as CACES, 1391 Processor, and SPECBASE.

9. To serve as the Corps' Center of Expertise for such designed programs as the Energy Monitoring and Control System, Solid Fuel Conversion, and Military Range Modernization Program.<sup>14</sup>

The concept of Centers of Expertise corresponded well to Huntsville Division's functional and non-geographic role, since these centers were defined as a division or district which possessed a demonstrated, creditable, technical capability in a specialized subject area that could be of beneficial use to other Corps field offices. This capability could reside in a single person or could rest in the organization as a whole and apply to civil and/or military work. The services rendered by a Center of Expertise were advisory unless requested to be otherwise by the FOA seeking assistance. The responsibilities of a Center of Expertise were threefold:

- Maintain within its capability state-of-the-art technical competence and awareness in its assigned specialty.
- Provide advisory assistance to other FOAs.
- Provide design services in their assigned specialty.<sup>15</sup>

During 1982-1987, Huntsville Division was administering 13 Centers of Expertise. This significant number of centers was assigned to Huntsville Division because of its unique management and procurement capabilities. Seven of these centers were assigned prior to 1982. These were Energy Monitoring and Control Systems, Solid Fuel Conver-

sion, Army Ranges, Army Facilities Component Systems, Army Ammunition Plants, Energy Engineering Analysis Program, and Railroads on Government property. The six centers that were established later were Intrusion Detection Systems, Electromagnetic Shielding, Mobilization Designs, Chemical Demilitarization Facilities, Child Development Facilities, and Third Party Contracting.<sup>16</sup>

The large number of Centers of Expertise assigned the Division led to some concern in 1983 that the Division might be unable to accomplish its work adequately in every given case. Headquarters, U.S. Army Corps of Engineers noted that some of the Division's Centers of Expertise consisted of diversified missions that did not have a corresponding design work load, a situation that might have hampered the levels of technical expertise needed for the optimum performance of assignments.<sup>17</sup> If there was some basis for this concern, the results proved otherwise. By the end of 1987, the Division's Centers of Expertise were held in the highest esteem and were "models for Centers of Expertise throughout the Corps."<sup>18</sup>

With a broad and complex mission and many Centers of Expertise, the Division performed 50 to 60 percent of its work for customers outside the Corps of Engineers.<sup>19</sup> These customers ranged from Army, Air Force, and Navy commands to agencies like NASA, Department of Energy, Department of Defense, and the Environmental Protection Agency to name just a few. Such a wide demand for support was indicative of the reputation the Division had acquired outside of the Corps.

Although the potential for conflict and disagreement between the Division and its customers was sometime unavoidably present, conflicts never placed a project in jeopardy. The diplomacy and tact exercised by the Division Commander and his key staff members played a major role in resolving conflicts with customers. Friction also developed because some organizations both inside and outside of the Corps expressed the view that Huntsville Division's missions could be assumed by other divisions. Headquarters, United States Army Corps of Engineers, however, did not share that point of view. Headquarters was strongly convinced that disbanding an organization like Huntsville Division would mean the loss of a team of experts, leaving a serious gap within the military. Headquarters knew how difficult it would be to replace an organization

with the unique and diversified capabilities of the Huntsville Division.<sup>20</sup>

Challenged by problems, Huntsville Division set out to minimize those conflicts by dedicating itself to customer satisfaction. Colonel Rudolph E. Abbott, Division Commander, introduced a number of actions designed to enhance what was termed "customer care." One of these actions provided a medium of communications between the Division and its customers by the use of a newsletter which provided customers with information about the Division's services and how they were conducted. He also initiated a series of surveys, one of which provided the Division staff with the opportunity to express its feelings about a particular assignment and its limitations, problems which they might anticipate, and attitudes toward a customer. The survey was intended to identify any internal problems that might affect the staff's work. Another survey was aimed at the customer. Here the customer was asked to evaluate Division performance. Colonel Abbott also established a Customer Care Panel. Chaired by Colonel William A. Miller, Deputy Commander, the panel was designed to develop a program of customer education. The panel's primary responsibilities were to inform customers as to why and how the Division conducted business.<sup>21</sup>

Huntsville Division initiated other policies in its attempts to enhance customer satisfaction. It conducted quarterly project reviews with its customers, which included senior members of both organizations. Periodically, the Division prepared Customer Care Reports which explained different facets of its work to its customers. It also conducted a series of formal visits to Army ammunition plants, which proved to be very beneficial in providing a clearer role of Huntsville's support. The Division undertook many other actions in the area of customer care, proving that Huntsville Division was making every attempt to minimize the possibilities of misunderstandings and friction between itself and its customers.<sup>22</sup>

The successes Huntsville Division had achieved in satisfying customers proved that the Division was fully capable of handling the unique mission that had been placed upon it. Although by 1982 the Division had long since shed its single-purpose mission, by 1987, it had assumed a multitude of missions, far greater in number than it had ever anticipated, proof that the Division merited the confidence of

HQUSACE and other agencies in dealing with highly technical and sophisticated programs. With the continual addition of new programs to its work load, Huntsville Division's resources could no longer remain the same.

Chapter 2 is an attempt to highlight the several changes that occurred to its resources in order to meet the challenges of the period.

# The Division's Resources

The increase in number of missions inherited by Huntsville Division during the period of this history witnessed a work load that by 1987 had grown almost threefold since 1980. Such growth led inevitably to a significant increase in the number of personnel with diversified skills assigned to the Division, a staff that was organized to respond more readily to missions, a greater funding by HQUSACE and its customers, and a new training facility that was better able to handle the needs of the Corps. One of Huntsville Division's new challenges was to employ these resources in the most efficient manner possible. This chapter attempts to describe these resources and how they evolved.

## Division Commanders

During the period of this history, four Division Commanders served Huntsville Division: Colonel John A. Poteat, Colonel Rudolph E. "Jim" Abbott, Colonel Robert S. Lindsay, and Colonel Charles T. Myers III.

The characteristics and skills of a Huntsville Division commander were similar to those of commanders in other divisions and districts. Because Huntsville Division is a unique organization, however, special qualities and managerial talents were expected of its commanders. The highly diversified and skilled composition of the Division's work force demanded that commanders exercise careful judgment in employee relations. They needed to encourage the best results in their people, while conforming to requirements. They needed the ability to retain people with special -- and sometimes rare -- skills. One former commander aptly noted that a "good Division Commander must have the good feeling that the Division has specialized skills that cannot be found elsewhere."<sup>1</sup>

Because Huntsville Division's work crossed division and district boundaries, the Division's commanders had to excel in public relations and

diplomacy to avoid misunderstandings that could lead to costly delays or dissatisfied customers. Diplomacy was also important for the commander and the Division's relations with customers outside of the Corps. Finally, commanders had to demonstrate leadership in seeking missions suited to the Division's expertise, and in employing resources to meet new challenges.

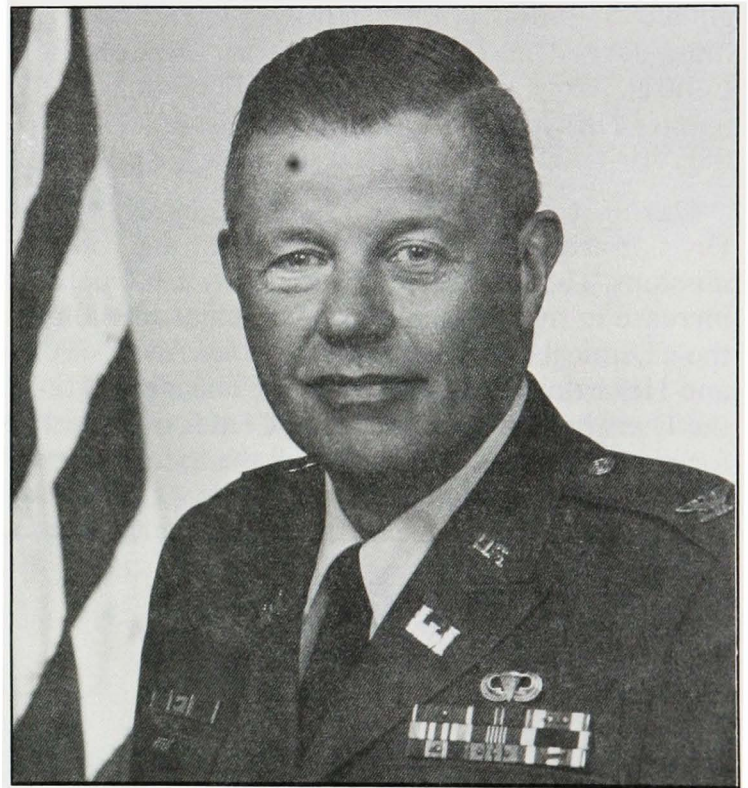

Fig. 1. Colonel John A. Poteat, Jr.

**Colonel John A. Poteat, Jr.** (Fig. 1). Colonel Poteat succeeded Brigadier General Max W. Noah as Division Commander in September 1980. A 1954 graduate of the U.S. Military Academy, Poteat later received a Master of Science Degree in Civil Engineering from the Massachusetts Institute of Technology. Colonel Poteat was a graduate of the Army's Command and General Staff College, Armed Forces Staff College, and Industrial College of the Armed Forces. He was a registered professional engineer in

the District of Columbia, Washington, and Alabama. Throughout his career he held a number of responsible command and staff assignments. He served as Assistant Professor and later as aide to the Superintendent of the U.S. Military Academy. Other positions included Resident Engineer, U.S. Army Engineer Mediterranean Division in Turkey; staff officer, Office of Deputy Chief of Staff for Logistics; Chief, Civil Engineer Branch, Logistics Directorate of the Office of Joint Chiefs of Staff; and Assistant Director of Civil Works, Pacific, in HQUSACE.

Colonel Poteat commanded the 588th Engineer Battalion (Combat) in Vietnam and later became Executive Officer of the U.S. Army Engineer Command in Vietnam. He commanded the 293rd Engineer Battalion (Construction) in Germany and later served as staff officer with Headquarters Central Army Group (NATO). He served as the Seattle District Engineer and was the Executive to the Assistant Secretary of the Army for Civil Works.<sup>2</sup>

During Colonel Poteat's tenure, the Huntsville Division acquired many highly technical and complex missions. The Division enjoyed nearly a 100 percent increase in missions, adding such major missions as the Chemical Demilitarization for the Army's Toxic and Hazardous Materials Agency. During this time, the Division was selected as the Center of Expertise for many areas, almost half of all the areas so designated by HQUSACE.<sup>3</sup>



Fig. 2. Colonel Rudolph E. Abbott

**Colonel Rudolph E. "Jim" Abbott** (Fig. 2). After Colonel Poteat retired on 31 July 1984, Colonel Abbott was named Division Commander. Abbott received a Bachelor of Science Degree in Mechanical Engineering from Oregon State University in 1958, and in 1967, received a Master of Science Degree in Mechanical Engineering from Arizona State University. He qualified as an Army pilot and parachutist, and was a graduate of the Army Command and General Staff College and Army War College. His varied assignments included serving as Deputy Commander, European Division, Germany; Commander of the 4th Engineer Training Brigade; Deputy Chief of Staff of the U.S. Army Engineer Training Center; and Commander of the 46th Engineer Battalion.

Colonel Abbott had an extensive background in personnel work, having served as Chief, Personnel Actions and Personnel Management Officer of the Military Personnel Center, as well as Personnel Management Officer in the Army's Office of Personnel Operations.<sup>4</sup>

During Abbott's tour of duty at Huntsville Division, several significant events occurred. Stressing the theme "Achieving Excellence as Leaders in Customer Care," Abbott instituted a policy that facilitated dramatically improved customer relationships. A support staff known as Information Management was organized, and Abbott implemented a major reorganization in which the functions of the Systems Engineering Division were fused with the Engineer Division. In February 1986, construction began on the new Training Center Facility.<sup>5</sup>

**Colonel Robert S. Lindsay** (Fig. 3). Colonel Lindsay became acting commander when Colonel Abbott retired on 13 February 1987. Until his appointment, Lindsay had served as Deputy Commander of the Division.

Colonel Lindsay started his military career in the enlisted ranks, which he left to attend college. Later, after graduating from Clemson University with a Bachelor's Degree in Civil Engineering, he returned to the Army. He later earned a Master of Engineering Degree from the University of South Carolina and completed all course and residency requirements for a Ph.D. in Engineering at the University of Mississippi.

Lindsay had a variety of assignments, including Engineer Platoon Leader; Aide-de-Camp to the Commanding General of Fort Belvoir; Engineer



Fig. 3. Colonel Robert S. Lindsay

Company Commander; Deputy District Engineer for Civil Works; Chief of the Environmental Branch in Headquarters, U.S. Army, Europe; Deputy Inspector General; and Battalion Commander. Prior to joining Huntsville Division, he was Director of Engineering and Housing at Fort McClellan, Alabama.

Colonel Lindsay was a graduate of the Army Artillery and Missile Officer Candidate School and the Army Command and General Staff College. He was a registered engineer in Kansas, North Carolina, South Carolina, and the Republic of West Germany.

**Colonel Charles T. Myers, III** (Fig. 4). Colonel Myers succeeded Colonel Lindsay as Division Commander 15 July 1987. He was commissioned in the Corps of Engineers in 1958, following his graduation from Rice Institute, where he received a Bachelor's Degree in Physics. He received a Master of Science Degree in Engineering Management from the University of Missouri in 1972. Myers is also a graduate of the Armed Forces Staff College and Army War College. Colonel Myers has held several command and staff assignments. Some of his major assignments included Assistant Director of Civil Works for Lower Mississippi and Gulf Areas in HQUSACE; Commander of the 4th Engineer Battalion, 2nd Training Brigade at Fort Leonard Wood,

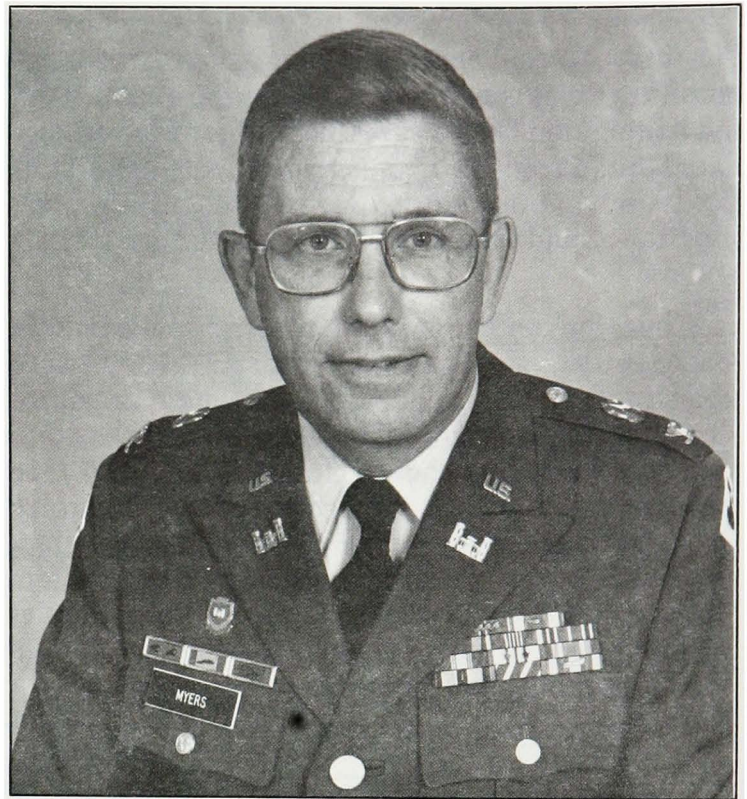

Fig. 4. Colonel Charles T. Myers III

Missouri; Director of Facilities and Engineering at Fort Sam Houston, Texas; Engineer Battalion and Group Operations Officer in Vietnam; and Engineer Company Commander. Prior to his appointment to Huntsville Division, he was Commander of the Jacksonville District.

## Organizing the Staff

During most of 1982, the Division's five technical divisions were Engineering Division, Systems Engineering Division, Construction Evaluation and Management Division, Procurement Division, and Corps of Engineers Training Management Division. The seven advisory and administrative offices were Resource Management Office, Office of Administrative Services, Automatic Data Processing Center, Office of Counsel, Public Affairs Office, Personnel Office, and Safety Office. The number of liaison offices varied, depending upon the number of projects. The two field project offices were in the U.S. Army Materiel Development and Readiness Command (DARCOM), now Army Materiel Command (AMC) Munitions Production Base Support Agency at

Picatinny Arsenal and at the Mississippi Army Ammunition Plant construction site. At the end of 1982, the Automated Data Processing Center was redesignated the Automation Management and Support Office with two branches: Computer-Aided Engineering Branch and Information Systems Branch (Figs. 5 and 6).

While the staff organization remained relatively stable in 1982, the following year saw several major changes. (Fig. 7). Changes included the reorganization of Systems Engineering Division and the addition of two new branches to Huntsville Division. One branch was the Special Projects Branch, which provided engineering support and planned development supporting the Military Studies Development Program. A second branch -- the Military Studies Development Branch -- conducted military contingency planning and determined requirements for

response to emergencies, natural disasters, and military crises.<sup>9</sup> Furthermore, the Planning Branch of the Systems Engineering Division was reorganized, adding mobilization and operations planning to its responsibilities.<sup>10</sup>

Also during 1983, functions of the Construction Evaluation Management Division were modified by deleting two branches. Design and construction evaluation were placed directly under the division chief, and functions formerly belonging to the Construction Management Branch were transferred to the Project Management Branch of the Engineering Division. These functions were established in the Project Management Branch as a Construction Category. The design functions already being performed by the branch were designated the Design Category. The Project Management Branch was further reorganized by establishing an Environmental

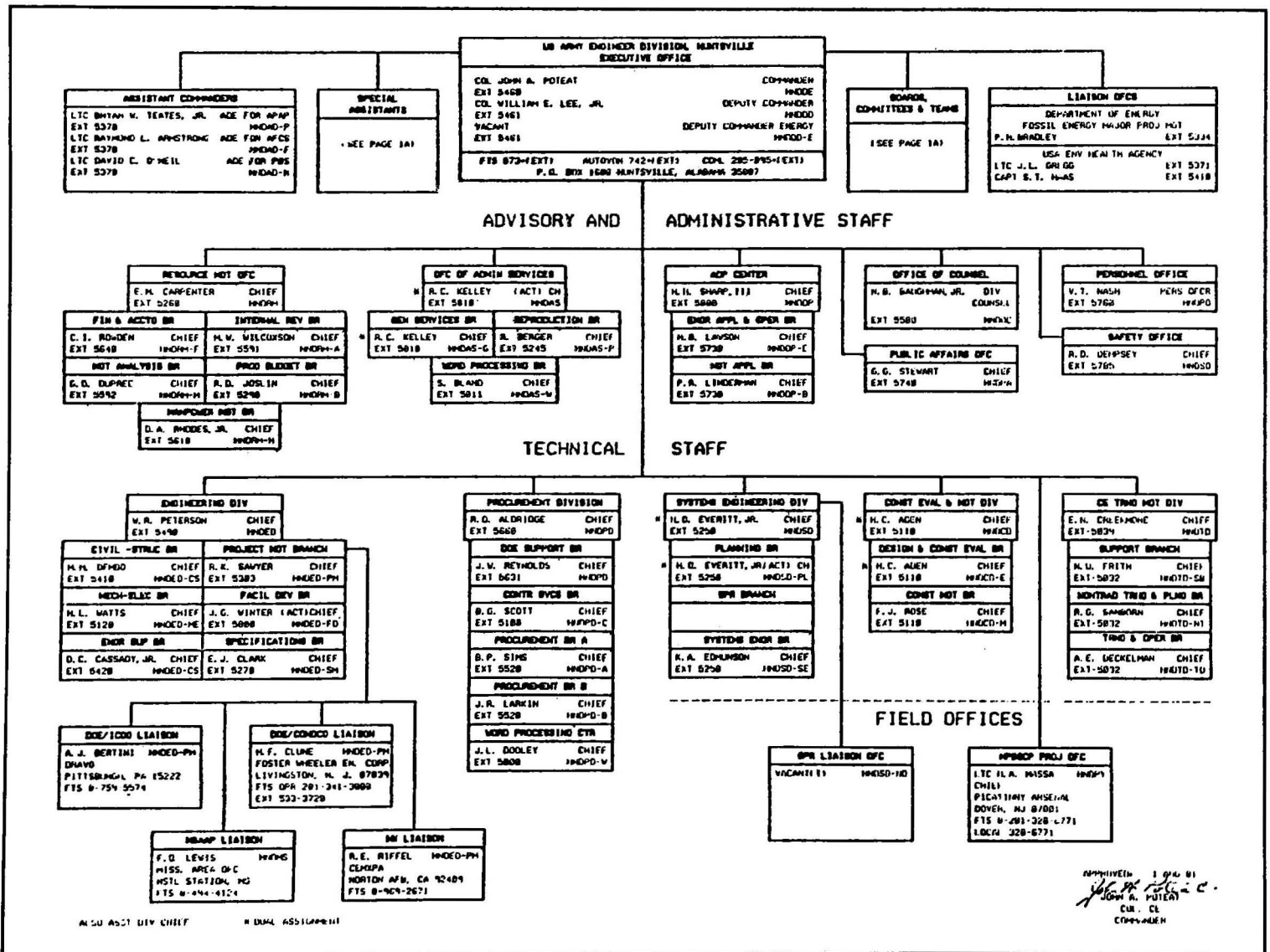

Fig. 5. Organization Chart, 1 August 1981

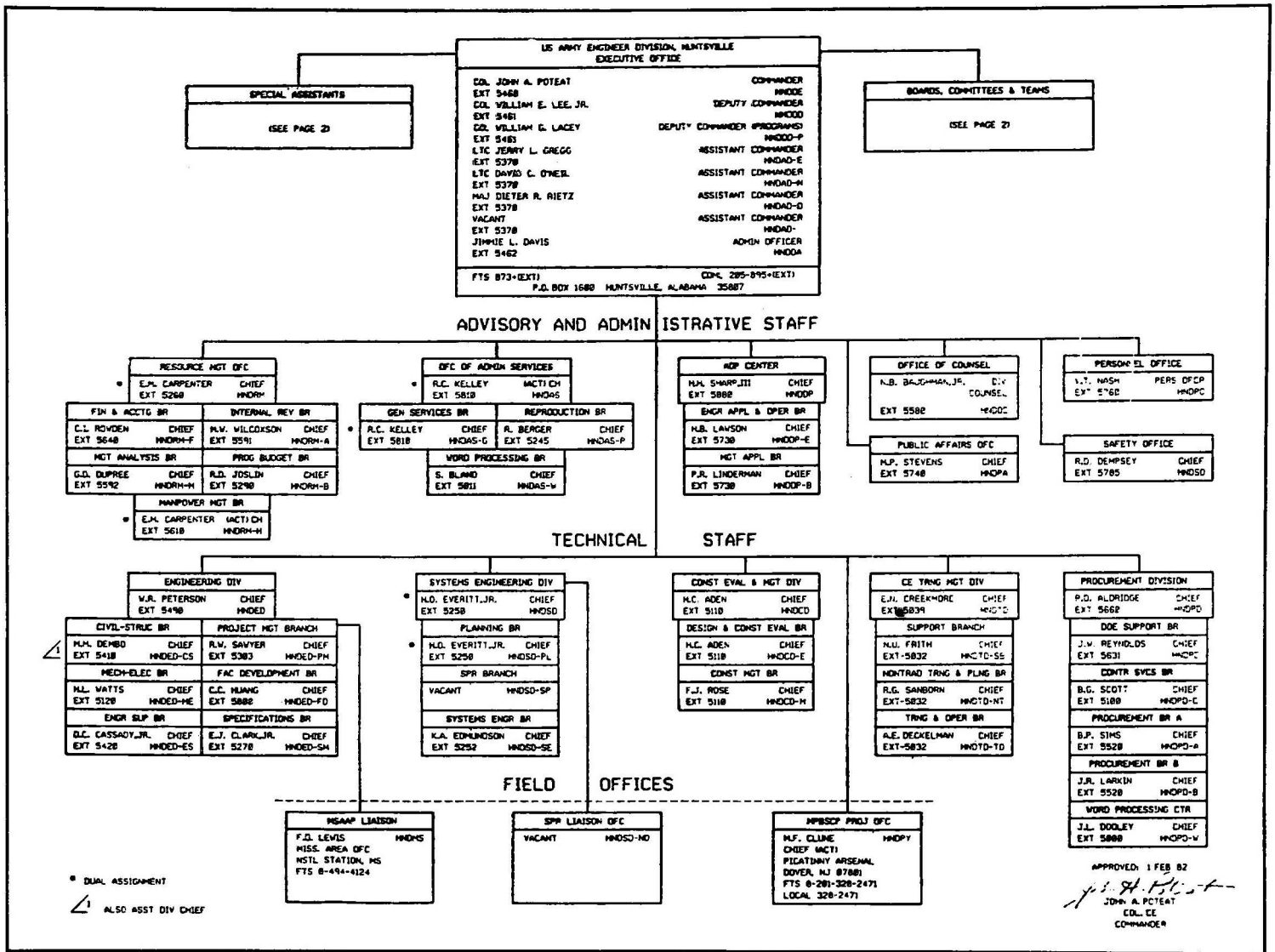

Fig. 6. Organization Chart, 1 February 1982

Category. 11

The title of Department of Energy (DOE) Support Branch of the Procurement Division was redesignated the Acquisition Management Branch. The Acquisition Management Branch retained its contracting expertise and would be assigned high-technology acquisition activities for the Huntsville Division.<sup>12</sup>

Two new sections were added to the Finance and Accounting Branch of the Resource Management Office. The Systems and Control Section was created because of new functions initiated as a result of the implementation of the Corps of Engineers Management Information System (COEMIS).

The Disbursing Section was organized to align the organization with HQUSACE's structure and to provide better disbursing functions.<sup>13</sup>

Perhaps the most significant change in 1983 was the elimination of the Civilian Personnel Office (CPO) from Huntsville Division's administration because of a consolidation of CPOs in the Corps. The Division's Personnel Office became a sub-office of HQUSACE's CPO.<sup>14</sup> The principle reason for the Corps-wide consolidation was to maintain the integrity of the Corps organization and to reduce the number of manpower requirements needed by the Corps to operate CPOs. A manpower study conducted by the Department of the Army concluded that money and manpower spaces would be saved if some CPO consolidation took place, including Corps CPOs. Since Army commands and their subordinate organizations were generally larger than most Corps agencies, the Corps was concerned that some loss of independence would occur and that responsiveness and understanding of the Corps would be significant-

ly reduced.<sup>15</sup>

Consolidation within the Corps meant that nineteen of its CPOs would be discontinued, Huntsville Division's one of them. Under the Army's policy, Huntsville Division's CPO would have been absorbed by the Missile Command at Redstone Arsenal. Yet, under Corps policy selected divisions' and districts' CPOs would be consolidated with each other. Basically, each division would be authorized one CPO. Huntsville Division's CPO was to be consolidated with some other Corps CPO since it had no subordinate districts. The two most probable CPOs for Huntsville to consolidate with were the South Atlantic Division in Atlanta, Georgia, or the Nashville District in Nashville, Tennessee. The result of the consolidation would have been that the Division would be serviced by some other Corps CPO. However, Colonel Poteat proposed that the Division's

CPO be made a suboffice of HQUSACE's CPO. The Chief of Engineers agreed, and the Division CPO became a suboffice of HQUSACE.<sup>16</sup>

During the latter part of 1984, the Internal Review Branch of the Resource Management Office and the Specification Branch of the Engineering Division were discontinued. An Audit Office, created from the discontinued Internal Review Branch, was added to the administrative staff. The Specifications Branch was merged into the Engineering Support Branch of Engineering Division. Other changes occurring at this time included the redesignation of two branches in the Automation Management and Support Office, one becoming the Integration and Operations Branch, the other the Systems Design and Programming Branch.

One of the most important changes occurring during the period of this history was the discontinua-

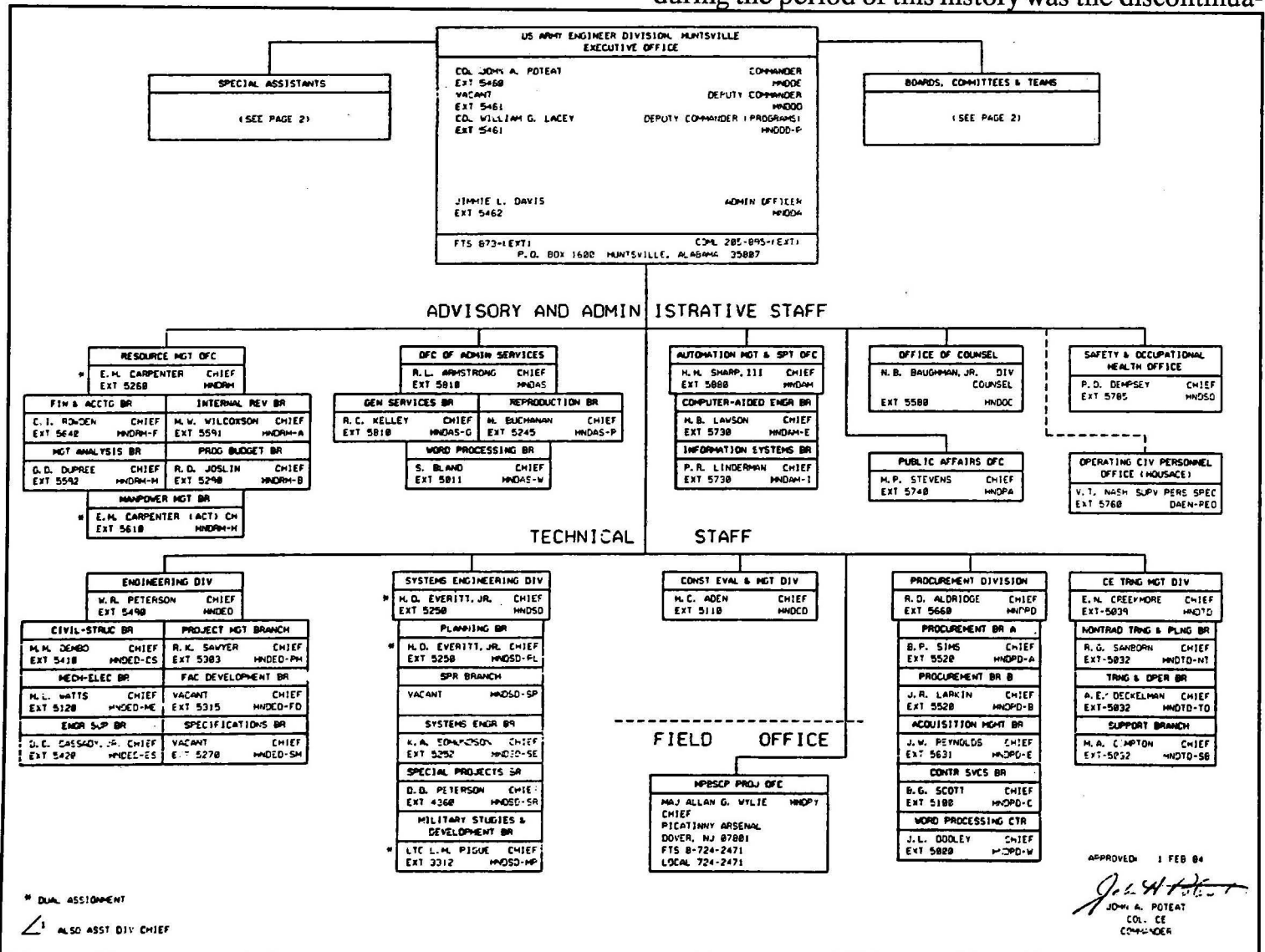

Fig. 7. Organization Chart, 1 February 1984

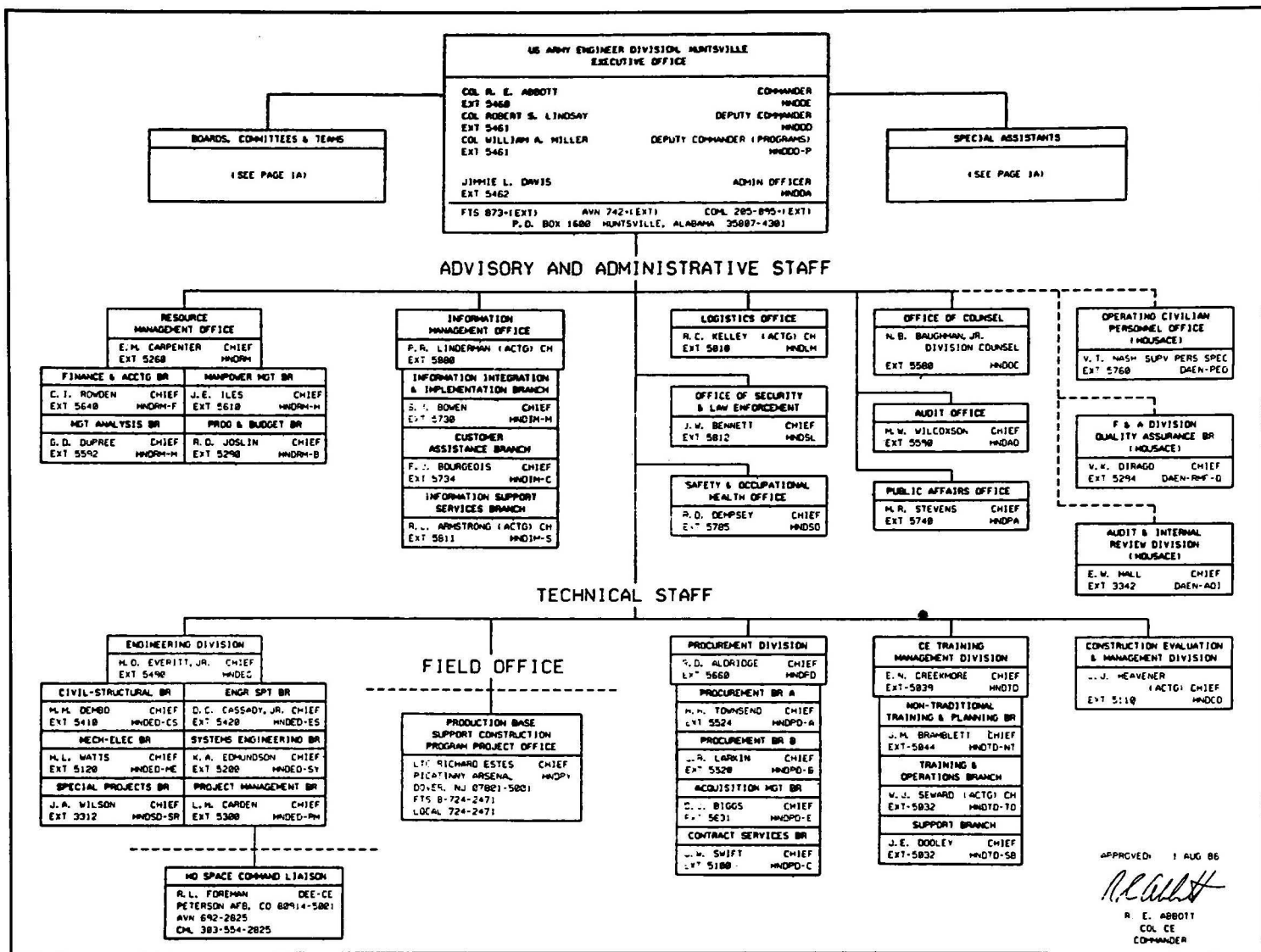

Fig. 8. Organization Chart, 1 August 1986

tion of the Systems Engineering Division and the reestablishment of its functions as a branch under the Engineering Division. In 1981, the Strategic Petroleum Reserve Division was redesignated as the Systems Engineering Division, retaining most of the old division's functions except for its connection with the Department of Energy.

Later, because Engineering Division and Systems Engineering Division had many common functions requiring coordination between the two, some argued that combining these divisions would streamline operations and could lead to manpower savings. Realizing that the two divisions had similar functions, Colonel Abbott decided to combine them. In January 1986, HQUSACE approved the change.<sup>17</sup>

In late 1985, as a result of the establishment of the Army's Information Systems Command, HQUSACE

directed the Division to establish an Information Management Office. Army Regulation 25-1, the Army Information Program, contained the policies, responsibilities and procedures governing information management. Automation (including office automation), communications, audio visual, records management, libraries, printing, and publication were consolidated under one office. In August 1986, the Information Management Office was permanently created with three branches: Information Integration and Implementation, Customer Assistance, and Information Support Services.<sup>18</sup>

The purpose of the new office was to automate, where feasible, and integrate all functions formerly conducted by the Administrative Services Office and the Automation Management Office. While the new office absorbed nearly all the information functions

of the Administrative Services Office as well as the word-processing capabilities of the Contracting, Engineering, and Training Divisions, there were a few functions it did not absorb. These were consolidated under a new Logistics Support Office which handled such matters as space and facilities management, travel, transportation, motor vehicles, supply, and property management. Also in November of 1986, the Procurement Division's title was changed to Contracting Division.<sup>19</sup>

Creating an Information Management Office and Logistics Support Office was to help centralize common or related functions, particularly those functions which were information-related and potentially could be automated. While significant progress was made by the end of 1987 to bring functions in line with this reorganization, there were still some logistics areas that were not as yet consolidated within the

Logistics Support Office.<sup>20</sup>

In 1986, HQUSACE established an Internal Review Office and a Quality Assurance Branch and located them in Huntsville. These two organizational entities were part of HQUSACE, not Huntsville Division. The Division entered into an agreement with HQUSACE to provide administrative support to these two units. That same year ended with the establishment of an Office of Security and Law Enforcement (Fig.8).

Two other changes were made to the Division's staff in 1987.

One was the addition of the Ground-Based Laser Area Design Office as a branch of the Engineering Division. The other change was the addition of a Systems Branch under the Resource Management Office (Fig. 9).

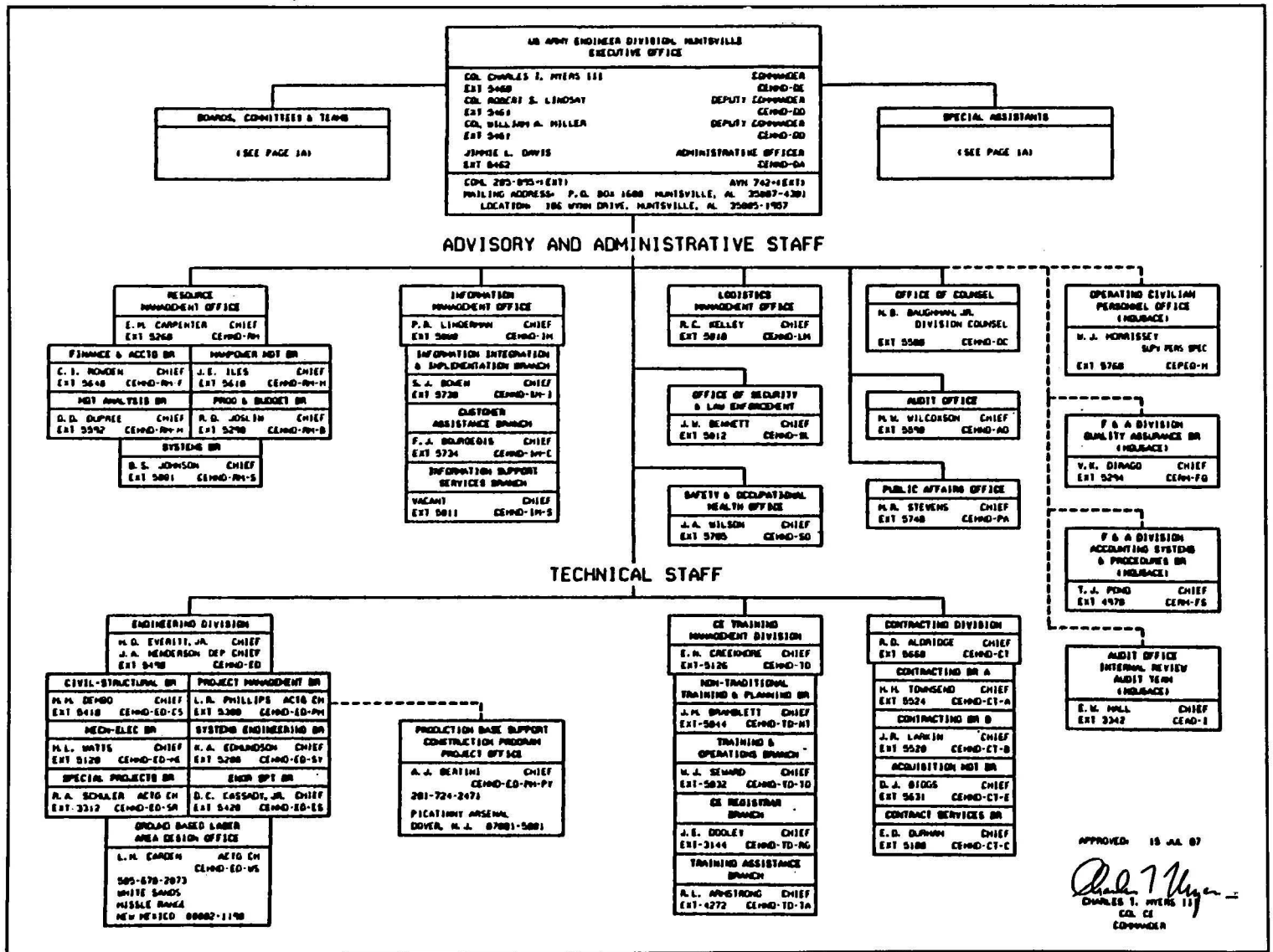

Fig. 9. Organization Chart, 15 July 1987

## Personnel

Huntsville Division's uniqueness contributed to high morale and esprit de corps. Creativity, professionalism, and personal integrity were common among Division employees. A survey of employee attitudes conducted by the U.S. Office of Personnel Management (OPM) in 1984 showed that the Division had a "highly motivated and dedicated workforce." It noted that employees "like their work, are more satisfied than not with their opportunities, feel their skills are being utilized, are helped by supervisors and encouraged by co-workers, and are generally well informed on personnel matters that affect them." The Office of Personnel Management concluded that the Division's civilian employees were well above average.<sup>21</sup>

These observations were also true in 1987. At that time, Brigadier General J. Offringa, who headed an HQUSACE inspection team, noted that the "state of morale, esprit de Corps, and professionalism in the Huntsville Division is outstanding." He explained why this was so:

USACE has, in this division, a unique capability to accomplish high priority, critical missions. The breadth and depth of expertise is indeed impressive. Special skills in contracting, training management, nuclear effects, and other technical areas are found in no other organization in the Corps.<sup>22</sup>

**Strength.** The following table reflects the assigned strength of civilian employees at the end of each fiscal year:

**Table 1**  
**Assigned Strength of Civilian Employees<sup>23</sup>**

Fiscal Year	Other than	
	Full Time Permanent	Full Time Permanent
1982	397	34
1983	433	36
1984	455	30
1985	472	42
1986	454	15
1987	471	53

The civilian personnel strength at the end of 1987 was distributed within the Division as follows:

**Table 2**  
**Civilian Strength Distributed Within the Division<sup>24</sup>**

	Full Time Permanent	Other than Full Time Perm.	Total
<b>Executive</b>	6	3	9
<b>Advisory Staff</b>			
Personnel Management	42	6	48
Information Management	42	9	51
Logistics	6	0	6
Audit	3	0	3
Counsel	4	0	4
Public Affairs	3	0	3
Security	2	0	2
<b>Total</b>	<b>102</b>	<b>15</b>	<b>117</b>
<b>Technical Staff</b>			
Engineering Division	264	25	289
Contracting Division	35	4	39
Training Mgt. Division	45	2	47
<b>Total</b>	<b>344</b>	<b>31</b>	<b>375</b>
HQUSACE	19	1	20
<b>Grand Total</b>	<b>471</b>	<b>50</b>	<b>521</b>

With the exception of fiscal year (FY) 1986, the Division enjoyed a steady growth in civilian employee strength, paralleling increased missions. The Division was successful, gaining personnel authorizations from HQUSACE. One former commander said, "we got good support . . . we did well."<sup>25</sup> The opposite was sometimes true, however. In FY 1987, the Division received about 15 percent fewer spaces than requested.<sup>26</sup>

Because manpower resources were frequently limited and Corps missions were constantly increasing, HQUSACE insisted that manpower be used efficiently. Because of its varied missions and high visibility, Huntsville Division had to employ its professional staff wisely and effectively.

**Classification.** In May 1982 the Division was apprehensive over the reduction in the high-grade position ceiling imposed by HQUSACE. High-grade position ceilings usually applied to grades GS-11 and above. The Division found itself in a situation where missions were increasing both in numbers and complexity, while its high-grade position ceiling was being reduced from 113 in FY 1981 to 99 in FY 1982. The Division commander was convinced that a reduction-in-grade ceiling would harm mission performance, especially on high-technology strategic programs.<sup>27</sup> After Colonel Poteat made a strong appeal to save these high grades, HQUSACE returned ten spaces previously removed. The same concern was again felt in 1983 when HQUSACE reduced the ceiling to 99. In view of the fact that the missions had grown significantly since FY 1980, the Division could not afford to lose high technology engineers.<sup>28</sup>

The problem of high-grade ceiling reductions was a continual one. To avoid any disruptive action that these reductions might bring about, the Chief of Engineers directed its organizations to stabilize their GS/GM-11 through 15 grades immediately. The Corps sought to decrease high grades through established position management practices.<sup>29</sup> To overcome this perennial problem, Colonel Abbott believed the Division had to "aggressively and innovatively" examine every vacant or new position to determine whether it could be performed at a lower grade. Although the Division had not done well in this respect, Abbott was convinced it must hold down grades to avoid imposed quotas.<sup>30</sup>

**Hiring.** Generally speaking, the hiring of civilians was not a serious problem. Although Huntsville was a city with several federal defense agencies and defense contractors, competition for high technology engineers was seldom a serious problem. Civil engineers were usually plentiful and mechanical engineers were in fair supply. Perhaps the one area that gave the Division some concern was the shortage of electrical instrumentation engineers, a phenomena that existed Corps-wide. There was a considerable amount of competition for these positions, particularly from NASA and the U.S. Army Missile Command.<sup>31</sup>

The Division fared well in all other respects. Division employees were able to accomplish their work despite shortages. When the Division did not have the necessary personnel, work was contracted or someone was detailed from Mobile District.<sup>32</sup>

**In-house Training.** The Division took considerable advantage of the opportunities offered by its in-house training management program. During FY 1985, there were 610 individual cases of training, costing the Division \$538,740. This number rose to 778 the next year.<sup>33</sup>

Although in-house training was adequate, there was a need for financial support in order to encourage employees, especially high-technology engineers, to pursue career-related advanced degrees. Financial support for those seeking advanced degrees was an area where the federal government was lagging behind private industry. However, Colonel Abbott believed that the government could become more competitive with industry and recruit the best personnel if the government provided better educational benefits. Huntsville Division would especially benefit from an enhanced training program, since the Division largely depended on employees with up-to-date high-technology skills. Colonel Abbott believed that government restrictions on employee training should be liberalized, and he asked HQUSACE to help bring about such a policy change.<sup>34</sup>

Headquarters, U.S. Army Corps of Engineers agreed that there would be significant benefits if the government supported such training. Headquarters encouraged the Division to provide financial support to training where courses were job-related, provided that the attainment of a degree was incidental to the training.<sup>35</sup>

**The Equal Employment Opportunity (EEO) Program.** There were significant signs that the EEO Program was working well within the Division. In 1982, every opportunity was provided to further affirmative action. Efforts to recruit and select minority and women engineers were generally successful. Although employment of minorities could not be compared with their counterparts in the local labor force, the Division successfully increased minority representation through alternative staffing and selection procedures.

During the first half of FY 1982, minorities and women received a proportionate share of the total training effort (11.8 percent and 30.8 percent, respectively). Of the 31 promotions during the same period, minorities received 19.3 percent and women received 67.7 percent. These figures represented slightly more than a proportionate share, when compared to their representation in the work force.<sup>36</sup>

Furthermore, the Division designated 6.5 percent of all authorized positions for co-op education, upward mobility, and career intern positions, and actively encouraged minorities and women to pursue these positions.<sup>37</sup>

By the end of 1987, the Division experienced further improvement in affirmative action. Much of the improvement was attributed to supervisors' and managers' increased awareness of the part they play.

The EEO Manager sponsored training for all supervisors and managers and monitored the critical element in supervisory/managerial performance standards and appraisals. Supervisors and managers received information about the work force composition through the quarterly Program Review and Analysis, and they got additional feedback about under-representation of minorities and women from the EEO Manager.

Other EEO improvements included a significant amount of minority participation in programs such as the Army's Career Intern Program, the Cooperative Education Program, the Federal Junior Fellowship Program, and an "Adopt-a-School" arrangement with Alabama A&M University, an historically black university. Furthermore, plans were made for the Division to participate in a job fair during February 1988, an event sponsored by the National Society of Black Engineers.<sup>38</sup>

The minority representation in the Division's work force at the end of 1987 was 11 percent, a 2.1-percent gain from 1986. Black representation was 7.7 percent and other minority representation was 3.3 percent. These figures reflected the highest minority representation levels achieved by the Division.<sup>39</sup>

The Federal Women's Program (FWP) enjoyed a successful period which led to an increase in women's standing within the Division's work force. Each year the program increased in effectiveness.

In 1985, two issues of a newsletter were published and an after-hours continuing education program, an in-house learning program, and an outreach program to other FWP activities were conducted.<sup>40</sup> Women were given the opportunity to progress in their careers, one attaining the grade of GS-13. A number of female engineers were hired during this period.<sup>41</sup>

## A New Training Center

Since 1978, the Training Management Center had been located on North Memorial Parkway in Huntsville. The leased facility, about 11,500 square feet, was considered too small, crowded, and inefficient to meet the growing needs of the training program. Even with a deliberate and planned approach, the training program and the number of people required to manage it grew faster than anticipated. Therefore, the Chief, Training Management Division began actions to acquire additional floor space. Studies conducted by the Division concluded that a facility consisting of 30,000 square feet was far more realistic in meeting the future needs of the program. The Division studied various alternatives to its training facility requirements.<sup>42</sup>

In seeking a new facility, the Chief of Engineers, Lieutenant General John W. Morris, said that any new facility should be affiliated with an academic institution. In 1979, the President of the University of Alabama, Huntsville (UAH) proposed that UAH build the center on its land and lease it to the Corps. The idea was attractive because it would provide the learning environment of a college campus along with the opportunity to use university faculty and facilities. The proposed facility would be located close to Division headquarters and to the airport.<sup>43</sup>

In April 1983, after various studies and negotiations, the university and the Division signed a Memorandum of Agreement. Through the efforts of Congressman Tom Bevill (D-Jasper, Ala.), a group of city and university officials met in Washington to develop their plans. This was an independent action.<sup>44</sup>

In July 1983, through Congressman Bevill's efforts, Congress passed legislation raising \$9.5 million for a learning center on UAH's campus. The appropriation was not considered a Corps of Engineers authorization. The Corps had several million dollars in a revolving fund, which the Chief of Engineers could use at his discretion. It was decided that the money for the new facility would come from this fund with the condition that it be paid back through the collection of tuition and fees from hotel and cafeteria accommodations. During discussions between the



Fig. 10. New Training Center under construction, March 1987.

Assistant Secretary of the Army for Civil Works, Congressman Bevill, and the Chief of Engineers, at that time, it was agreed that the university would provide the land as partial payment. Although this would change, it was agreed that the government was to own the facility, and the cost of maintenance was to be shared by both the government and university. The use of the building was to be shared by the Corps and the university's Continuing Education Center.<sup>45</sup>

Other negotiations about land, money, and the facility, led to a new agreement in October 1985, and a final Memorandum of Agreement was signed. Under the new agreement, UAH owned the building, but the Corps had priority for use of the facility for a fifty-year period. Maintenance of classroom areas was to be shared -- 75 percent by the Corps and 25

percent by the university. The rest of the building, which consisted of a hotel and dining area, was to be self-supporting. After fifty years, a new agreement could be negotiated, with the probability that the Corps would pay rent to the university.<sup>46</sup>

Once the legalities were settled, construction was planned to begin in 1986 and be completed in late 1987. The Division's Architectural Section designed the structure in 1985, with university input. The new facility was to consist of 93,000 square feet of space, and of this amount, the Corps Training Center was to occupy 34,500 square feet, including four classrooms, one executive classroom, a lounge, and administration offices. The center of the complex was to feature a three-story atrium. Hotel accommodations were to consist of 100 guest rooms, three executive suites, and

facilities for the handicapped. In addition, the center was to contain a kitchen and a dining room with a capacity of 110.<sup>47</sup>

A contract for \$6,296,775 was awarded in February 1986 to the Bryson Construction Company of Decatur, Alabama, to build the center. The construction contract was managed by the Mobile District. On 26 February 1986, during ground-breaking ceremonies, the university made the surprise announcement that the new facility would be named the "Tom Bevill Center for Professional Development and Continuing Education" for the congressman who had been instrumental in its establishment (Fig. 10).<sup>48</sup>

On 24 December 1987, the center was officially declared complete. Most of the furniture and furnish-

ings, which the Division's Contracting Division had acquired for about \$1 million, were already in place by the end of the year (Fig. 11). On 15 January 1988, the center was officially declared open with a ribbon-cutting ceremony.<sup>49</sup>

## Funding the Missions

Adequate funding was seldom a serious problem in the Huntsville Division. As one mission declined or was removed, another took its place. For example, when the MX mission was discontinued in 1981, it was soon replaced by strategic defense systems. About 90 percent of Division's missions were project-funded.<sup>50</sup>

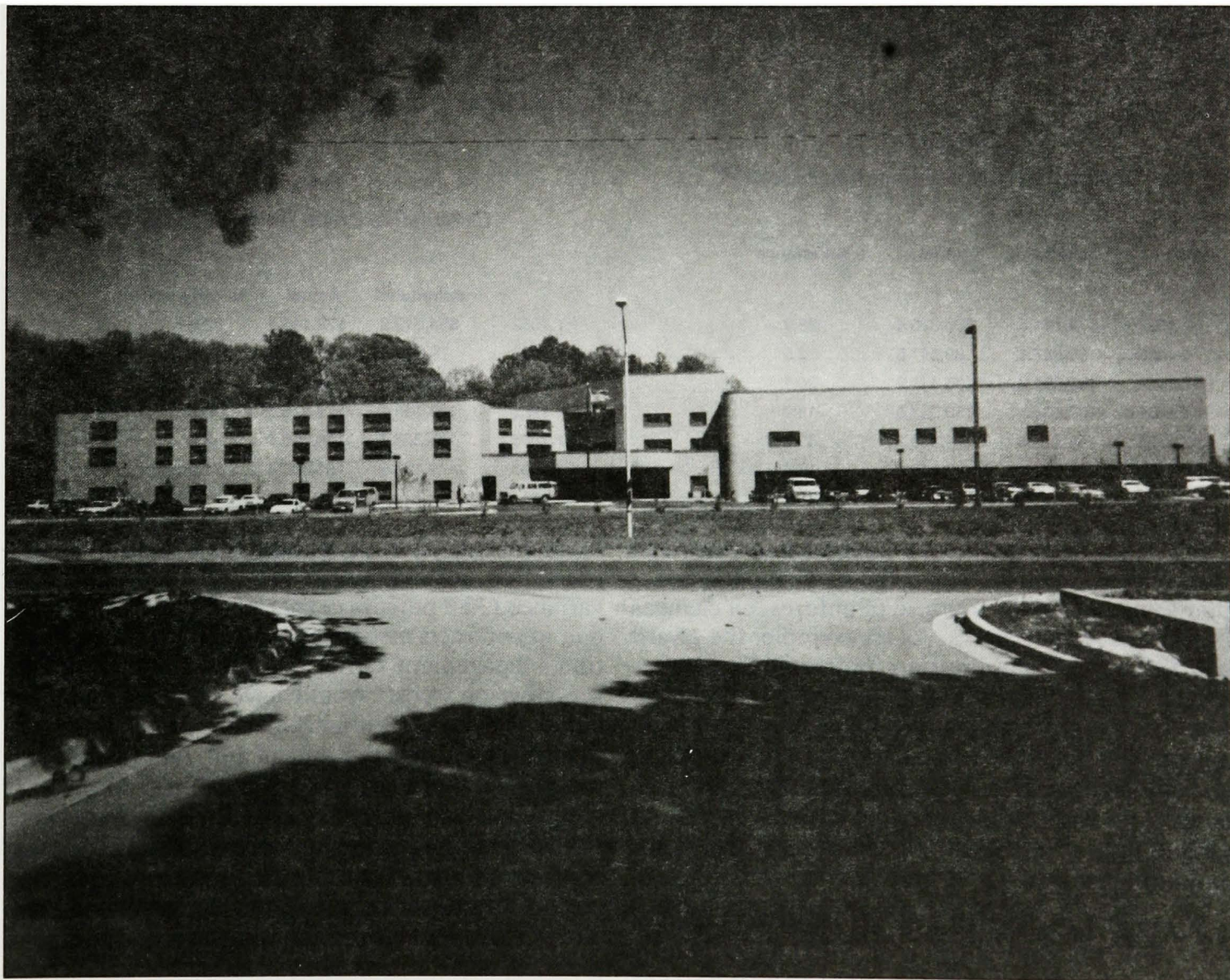

Fig. 11. Bevill Training Center completed.

There were always shifts occurring in programs, and part of the challenge was adjusting to these shifts. In FY 1986, the most dramatic change was the downward shift in funding of a classified special project from an estimated \$59 million to an actual \$17.6 million. The Munitions Production Base Support Program was also down from an estimated \$87.4 million to an actual cost of \$65.7 million. On the other hand, the Chemical Demilitarization Program rose from an estimated \$53.4 million to \$88.7 million. Change in several of the smaller programs was also evident. For example, Mobilization Drawings declined from \$3.1 million to \$252,000, and environmental programs for the Army Materiel Command fell from \$11 million to \$8.2 million. Work on Strategic Defense Initiative, however, grew from \$8.4 million to \$11.7 million.<sup>51</sup>

The following table reflects the constant growth in cumulative obligations during the period of this history:

**Table 3**  
**Cumulative Obligations (in thousands)<sup>52</sup>**

	Scheduled	Actual	% Variance
FY 1982	\$74,741.5	\$96,325.4	28.9
FY 1983	91,847.1	89,547.5	-2.5
FY 1984	195,882.2	156,431.2	-20.1
FY 1985	189,504.1	155,332.8	-18.0
FY 1986	148,129.8	194,958.2	31.6
FY 1987	149,207.1	177,303.9	18.8

The data in Table 3 reflects the extent to which total obligations grew during the six-year period. Actual payments varied because of unforeseen changes in mission requirements. As an example, the award of a \$3.3 million mobilization contract in September 1982 drove the Guide Specifications and Technical Manuals Program obligations above what had been anticipated. On the other hand, during that same period, Munitions Production Base Support Program obligations were below schedule because \$4 million for site improvements at the Mississippi Army Ammunition Plant was delayed.<sup>53</sup>

A significant shortfall in FY 1984 of \$39 million (20.1 percent below anticipated costs) was primarily attributable to the classified special project because

of slow program direction and proposal solicitation and evaluation time that was longer than expected.<sup>54</sup> A shortfall in FY 1985 of \$34 million, or 18 percent, was again attributable to the classified special project because of program changes and efforts to definitize future plans.<sup>55</sup>

The sudden jump from a shortfall in FY 1985 to an overrun of 31.6 percent in FY 1986 was attributed primarily to the many unanticipated increases in scopes of work for the Chemical Demilitarization Program and the Defense Environmental Restoration Account.<sup>56</sup> The average of 18.8 percent experienced in FY 1987 was attributed to the additional tasking for the Defense Environmental Restoration Program and the establishment of a project office at White Sands, New Mexico, for the Strategic Defense Command, and to the \$12.5 million in Chemical Demilitarization obligations that had not been expected to occur until FY 1988.<sup>57</sup>

The following table reflects the expenses incurred by the Division during 1982-1987:

**Table 4**  
**Cumulative Costs (in thousands)<sup>58</sup>**

	Scheduled	Actual	% Variance
FY 1982	\$54,319.2	\$72,146.1	32.8
FY 1983	79,955.6	70,719.6	-11.6
FY 1984	96,579.8	90,717.1	-6.1
FY 1985	185,165.3	172,875.7	-6.6
FY 1986	185,266.6	178,555.7	-3.6
FY 1987	179,175.6	181,008.4	1.0

As in the case of obligations, actual versus scheduled cost variances are reflected. The high variance (32.8 percent) experienced in FY 1982 was due to contracts associated with the Sinai Construction Management Office. Without these contracts, the Division's costs would have been 57.7 percent below schedule.<sup>59</sup> Variance declined to 11.6 percent below schedule at the end of FY 1983 for several reasons. In some instances slow billings on the part of the contractor delayed payments. In the case of the Railroads Program, the late receipt of funds delayed contract awards, resulting in lower costs for that period. Contracts on the Guide Specifications and Technical Manuals Program were awarded later than planned, and this also delayed costs.<sup>60</sup>

During the period of this history, Huntsville Division was fortunate to have enjoyed the essential resources to undertake the missions it had been assigned, many of them of a high technical nature. Without the strong and consistent support from higher headquarters, Huntsville Division could not

have undertaken these missions effectively. The remainder of this history is the story of how the Division fulfilled its responsibilities.

# Advanced Technology in Defense Areas of National Significance

## Presidential Strategic Initiatives

**Strategic Defense Initiatives.** With the cancellation of the SAFEGUARD Program in 1975, the Corps of Engineers continued its involvement in ballistic missile technology. Huntsville Division acted as the Corps' single point of contact for support to the Ballistic Missile Defense Program. The Division customers were the Ballistic Missile Defense System Command (BMDSCOM), the Ballistic Missile Defense Advanced Technology Center (BMDATC), and the Kwajalein Range Directorate. The Division's location in Huntsville with BMDSCOM and BMDATC enabled Division personnel to provide a wider range of engineering services.

One of the major aspects of Huntsville Division support in the Ballistic Missile Defense Program was the deployment of the Low-Altitude Air Defense System (LOADS), later renamed SENTRY. Major support work in the LOADS program included radiation transport methods, propellant testing, electronics radiation testing, nuclear weapons effects, and criteria development and design of tactical test facilities for White Sands Missile Range and Kwajalein Missile Range.

In FY 1982, BMDSCOM provided Huntsville Division about \$2.3 million to support the LOADS program. Test facilities construction was programmed for the two missile ranges in FY 1983. About \$5.4 million was appropriated for construction at White Sands Missile Range and nearly \$22 million for Kwajalein Missile Range. Huntsville Division prepared the designs for the tactical facilities under an architect-engineer (A/E) contract with support from the Fort Worth District and the Pacific Ocean Division. A preliminary deployment planning exercise identifying the facility support required from Huntsville Division and the Corps agencies for LOADS deployment was also completed.<sup>1</sup>

The Ballistic Missile Defense mission continued at

a rapid pace in Huntsville Division during 1983. During this year, President Reagan announced his Strategic Defense Initiative (SDI) Program with its long-range goal of eliminating the threat of strategic nuclear missiles. National policy changed from one of "strategic deterrence" to one of "strategic defense." The new policy emphasized "defense in depth" in support of SDI, with a balanced emphasis on technology, design, and construction of test facilities for the program. To meet this goal, the President established the Strategic Defense Initiative Organization at Department of Defense level. This organization was supported by the U.S. Army Strategic Defense Command (USASDC), successor to BMDSCOM. The Strategic Defense Command developed deployment concepts for which the Corps of Engineers supplied the facility support of both the concepts testing and the actual system deployment. The Chief of Engineers assigned program management responsibilities to Huntsville Division, and designated it USACE point of contact for USADC support.<sup>2</sup> The Division's broad experience acquired through support of BMD facilities made it the logical choice for this assignment.

The Division provided a wide range of support during this period to USASDC, the Defense Nuclear Agency (DNA), and other government agencies. That support ranged from feasibility studies through criteria development to the design, construction, validation testing, training, and life-cycle maintenance of hardened systems. Other support included participation at working group meetings and conferences, coordination of research and development activities at government laboratories, and preparation of formal documentation. The Division also was active in identifying problem areas and working with government agencies and private contractors to resolve research and development needs. By 1987, the workload became diverse as it included aboveground and underground nuclear testing (AGT/UGT), developing and testing of radiation-

hardened electronics; continued support in developing a survivable Battle Management Command, Control, and Communications Network for SDI application; and preparing special studies in supersonic impact and continuum mechanics for NASA, DNA, and USASDC. The Division prepared designs and undertook construction and life cycle maintenance for hardened facilities, conducted feasibility studies on the Rail Garrison Basing Mode, developed and executed a validation test program for Jam Resistant Secure Communications sites, and developed nuclear environments for SDI elements.<sup>3</sup>

The Division's advanced technology work included support to the DISKO ELM AGT/VGT. A two-year contract for testing the DISKO ELM AGT/VGT was initially estimated at \$3.5 million, but could reach \$8 million depending upon options awarded and available funding. Contractual support was also sought for the procurement, pretest, and post-test characterization of candidate optical sensor material samples (optical, window, and mirror materials).<sup>4</sup>

In the area of Vulnerability, Survivability, and Hardness, the Division provided technical, managerial, and contractual support to DNA in three areas: Rail Garrison, Hardness Verification/Surveillance Testing and Standards Program, and special studies in Electromagnetic Pulse and Electromagnetic Phenomena. Funding for this support was expected to reach about \$13 million by FY 1990.<sup>5</sup>

A significantly large project in SDI assigned to Huntsville Division in 1984 was the formulation of program documentation for a ground-based facility at White Sands Missile Range. As point of contact in SDI support, Huntsville Division assumed responsibility for the development and design of facility criteria for the Ground Based Free Electron Laser-Technology Integrated Experiment (GBFEL-TIE). The Division worked closely with Corps districts responsible for construction. Huntsville Division's work on this project included preparing appropriate environmental impact documentation, assisting the USASDC in selecting sites, developing facility criteria, preparing designs, and providing engineering and management support during construction. Because of the nature of the project and the relatively short design and construction schedule, innovative techniques were used during all phases of work.

In FY 1985, Huntsville Division received \$25,000 for the initial support to the GBFEL-TIE project, but in FY 1986, the amount rose to \$3.68 million, and in

FY 1987, funding soared to \$11.76 million. In FY 1988, however, funding was expected to be reduced to \$5.3 million, evidence of the uncertainties that surrounded national defense programs in advanced technologies.<sup>6</sup>

In 1987, Huntsville Division awarded a major contract to Bechtel National Inc., for the facility design of the GBFEL-TIE. The cost of the two phase project was expected to run between \$600 million and \$1 billion. The first phase of construction was to support low-power experiments, while the second phase was to provide for high-power tests. The design of individual components depended in part upon the selection of one of two competing free-electron laser technologies. The basic idea was for several ground-based lasers to radiate beams of hundreds of megawatts to a relay mirror in space. The mirror would then deflect the energy to a "fighting mirror" that would aim the beams at enemy missiles, thus destroying them.<sup>7</sup>

The next step was to select a site and award a construction contract for the new facility. The Orogrande site at White Sands Missile Range was selected as the location for the GBFEL-TIE, and a construction contract was awarded to Fluor Constructors, Inc. In January 1987, Huntsville Division began the design of the support facilities. To coordinate matters closely, the Division established a project office at White Sands Missile Range in April 1987. It consisted of 16 people on temporary duty until a permanent staff was hired.<sup>8</sup>

As previously noted, funding for the GBFEL-TIE was considerably reduced in FY 1988. The design budget for this project was originally estimated at \$26 million for FY 1988. By the end of December 1987, however, the budget was reduced to \$5.3 million as part of an overall Congressional reduction in SDI programs. Even though such reductions placed resources in an uncertain status, USASDC insisted that Huntsville Division maintain its resources and capabilities in this program at a high level. Then, if adequate funding became available in FY 1989, the Division could resume full-scale operations with little disruption.<sup>9</sup>

By the end of 1987, SDI activities constituted about 6 percent of Huntsville Division's budget.<sup>10</sup> USASDC continued to be an important customer, and Huntsville Division retained the ability to respond. In the final analysis, however, national policy would determine the future workload.

**Power Reliability Enhancement Program (PREP).** In 1981, the Joint Chiefs of Staff directed the Corps of Engineers to upgrade and modernize the electrical power supply used in critical command, control, communication, and warning sensor facilities. The Chief of Engineers directed Huntsville Division to assume the position of Project Manager for this project while working with the Facilities Engineering Support Agency (FESA), the lead agency and Technical Manager. The Facilities Engineering Support Agency was responsible for preparing site surveys and identifying requirements. This coalition formed the basis for PREP.<sup>11</sup>

On 8 January 1982, the Chief of Engineers outlined PREP responsibilities and duties of Huntsville Division. The Division was to assist FESA during Phase I of the program by providing in-house engineering and A-E contract services. During Phase II, the Division was to take the lead in developing long-range project criteria and producing a Design Features Manual for Major Fixed C<sup>3</sup> Power Systems. In addition, Huntsville Division was to monitor the design and construction undertaken by Corps divisions and districts and coordinate joint construction.<sup>12</sup>

The Facilities Engineering Support Agency controlled the funds for PREP. In FY 1982, it provided Huntsville Division with \$1.5 million for A-E contracts and \$239,785 for in-house engineering support. The Office of the Chief of Engineers added another \$47,000, which the Division used to award A-E contracts.<sup>13</sup>

Initially, the Joint Chiefs of Staff selected six sites to be evaluated for reliability and modernization of power facilities: National Military Command Center (The Pentagon), Alternate National Military Command Center (Fort Ritchie, Maryland), North American Air Defense Command (Cheyenne Mountain Complex, Colorado), Continental United States Ground Station (Buckley ANGB, Colorado), the PAVE-PAWS radar site at Otis Air Force Base (Massachusetts), and the PAVE-PAWS radar site at Beale Air Force Base (California).<sup>14</sup>

On 12 February 1982, two A-E contracts were awarded, one to United Engineers and Constructors of Boston, the other to Sverdrup and Parcel of St. Louis. The former contractor was to provide A-E services such as surveys, analyses, short-term planning, and preliminary long-term planning for the three eastern sites, and the latter company was to

provide similar services for the three western sites.<sup>15</sup>

By November 1982, both contractors completed their work. Meanwhile, Huntsville Division awarded a contract for the preparation of portions of the Design Features Manual and planned to finish the remainder in-house. While work seemed to be moving along smoothly in FY 1982, a shortage of funds in FY 1983 forced the Division to delay its supervision of A-E contracts.<sup>16</sup>

In FY 1983, three sites were added to PREP: National Military Intelligence Center (The Pentagon), a site at Thule Air Force Base (Greenland), and an unidentified ground station outside the Continental United States. In FY 1984, six more sites were added in the United States, Germany, and the United Kingdom. Nine more sites were added in FY 1985, two of which were in Germany and the rest in the United States. Three sites were added in FY 1986, two in the United States and one in Japan. While no new sites were added in FY 1987, two sites, one in Hawaii, the other in South Korea, were scheduled for FY 1988.<sup>17</sup>

Site surveys, data collection and analyses, and the preparation of programming documents were completed for the initial sites and those added through FY 1985. Contracts for the evaluation of the three sites added in FY 1986 were also awarded that same year, two of which were to be completed in February 1988.<sup>18</sup>

One important aspect of the PREP mission was the installation of an uninterruptable power supply (UPS) and a high-altitude electromagnetic pulse (HEMP). Both were protection improvements at the Alternate National Military Command Center in Maryland. That work evolved from the site evaluation completed in 1982 and was a vital link in upgrading the battle management command and control network. With the help of the Baltimore District, work on this project was completed in June 1986. Another major phase of this project was the HEMP Hardness Assessment and Validation Testing (HAVT), completed in September 1985. The Hardness Assessment Report on this work was sent to HQUSACE in November 1985.<sup>19</sup>

The first eight chapters of the Division's draft of the Design Features Manual for Major Fixed C<sup>3</sup> Power Systems were sent to the Study Advisory Group in October 1983. That body consisted of representatives from the Joint Chiefs of Staff, the Offices

of the Secretaries of Defense, Army, Air Force, and Navy, and the Defense Nuclear Agency, and was chaired by HQUSACE. After several delays, a final copy of the manual was furnished to HQUSACE in February 1986. At the request of the Space Command, the manual was revised and returned to HQUSACE for publication in August 1986. Once again its publication was postponed, this time at the request of the American Turbine Manufacturers Association. That organization requested that Corps revise the manual to include gas turbines as well as diesel engines as a designer's choice. By the end of 1987, Huntsville Division was in the midst of further revising the manual, deleting any direct references to the use of diesel engines. Huntsville Division was expected to complete the revised draft by April 1988 and to publish the manual by the end of FY 1988.<sup>20</sup>

When first initiated, PREP was to be a long-term project. Estimated work years varied from 4 in FY 1983 to 5.8 in FY 1986, ultimately dropping to 2.9 in FY 1987. While initial funding was between \$4 and \$5 million, it dropped to \$366,353 by FY 1987.<sup>21</sup>

## Mobilization

**Army Facilities Components Systems (AFCS).** The Army Facilities Components System had its beginning in 1951. World War II and Korea had demonstrated the need for an emergency construction planning and supply system. This mission was transferred to Huntsville Division from FESA in mid-1978.<sup>22</sup> Its purpose was to provide planning guidance, construction drawings and bills of material needed for Army construction in a theater of operations or during a period of mobilization. The system was to plan for construction under various climatic conditions. The Army Facilities Components System provided the functional designs for developing base plans and facility needs for both contingency and operational plans. The system also created engineer force requirements needed to support tactical forces, an important direct link to the combat engineer.

During the period of this history, emphasis was placed on the automation of AFCS for users and the maintenance and enhancement of AFCS data.<sup>23</sup> The data consisted of four Army Technical Manuals: temperate climate, tropical climate, frigid climate,

and desert climate. Huntsville Division's job was to maintain, update, and modernize these manuals. Proposed changes came from using agencies during annual reviews; when Tables of Organization and Equipment or missions were altered; when materials and procedures became obsolete; when errors were discovered; or when simplification became possible.

In 1982, the total funding for this program was about \$1.3 million, or 1 percent of the Division's budget.<sup>24</sup> In FY 1982, nine new projects with a total dollar value of \$533,013 were started. Furthermore, six projects with a total dollar value of \$395,466 were completed during the same period. At the end of the fiscal year, 12 projects with a total dollar value of \$1.3 million were continued into FY 1983.<sup>25</sup>

By 1984, Huntsville Division was developing budgets for AFCS and preparing and presenting a Program Review and Analysis Briefing. The Division also monitored related technological advancements, planned projects, arranged periodic exercises of the system, and developed detailed scopes of work. Division personnel continued to negotiate and award design contracts, coordinate with Corps laboratories and other agencies, review designs, and provide technical advice on the use of AFCS.<sup>26</sup>

In FY 1987, the AFCS mission was funded at \$1.34 million. Funding was reduced to \$1.01 million for FY 1988, calling for a re-evaluation of priorities. Reduced funding was expected to prevent the completion of 11 projects under contract.<sup>27</sup>

**Federal Emergency Management Agency Key Worker Blast Shelter Program.** In 1982, the Federal Emergency Management Agency (FEMA) requested that the Corps support the Key Worker Blast Shelter (KWBS) Program, thus introducing another new mission to Huntsville Division. The Federal Emergency Management Agency develops plans for civil defense against nuclear attack and preparedness for other emergencies. One aspect of civil defense is the protection of industrial sites to ensure continued production after enemy attack. This includes construction of shelters for key defense industries and their workers.

The Chief of Engineers appointed Huntsville Division as the lead Field Operating Agency for the KWBS Program. The Division was to conduct a literature search to evaluate the state-of-the-art in shelter design for nuclear weapons effects. Division personnel would then define design procedures and

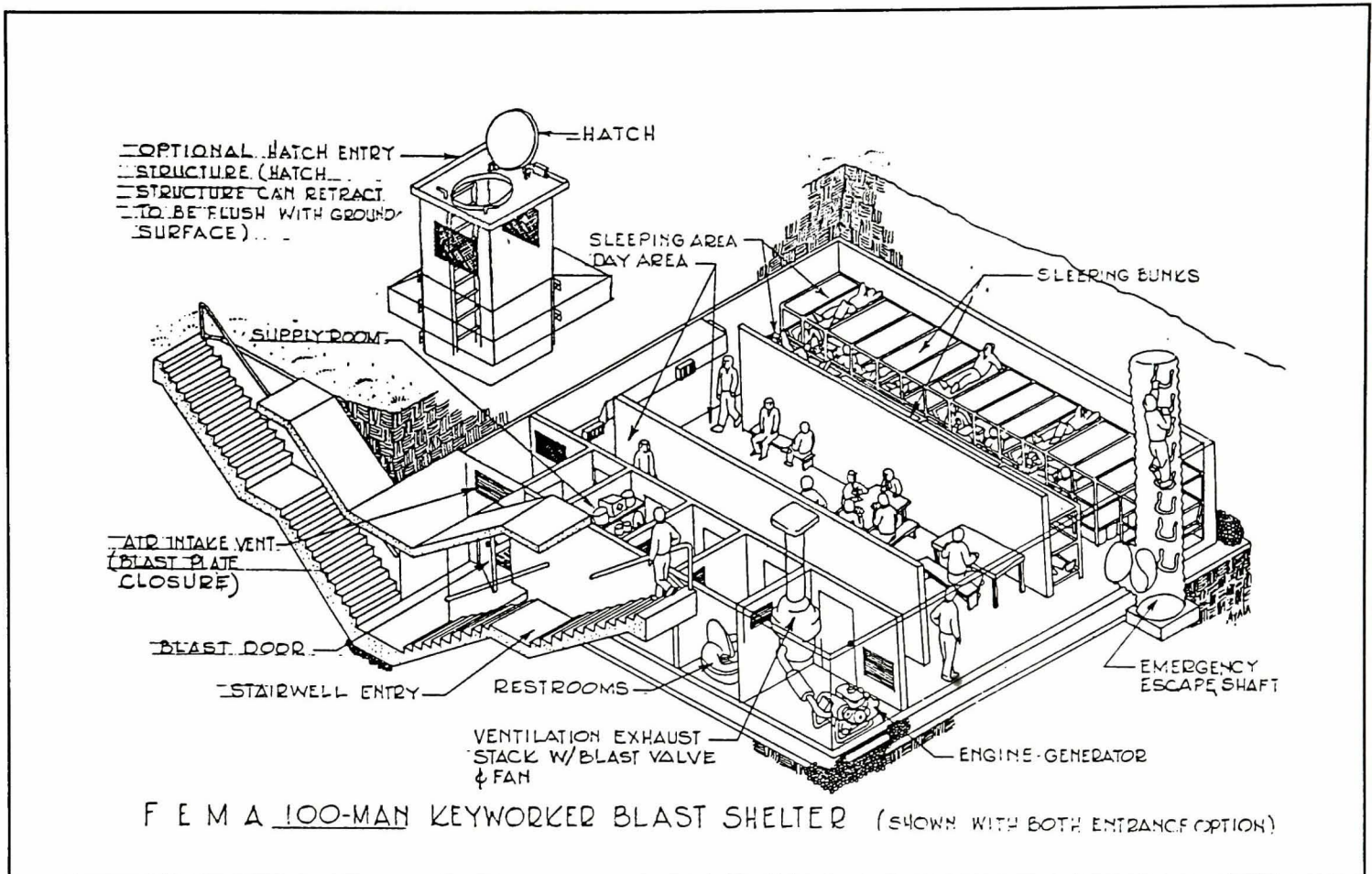

Fig. 12. Revised 100-person FEMA Keyworker Blast Shelter

develop workable, cost-effective designs for permanent and transportable shelters for use in prototype construction programs. The Division also would develop construction management plans to facilitate rapid deployment of the shelter program. Following that, the Division would implement a prototype shelter construction program to validate a FEMA-USACE-industry working mechanism and obtain construction costs, and incorporate "lessons-learned" into final designs.<sup>28</sup>

Huntsville Division managed the overall program while working with the Corps' Waterways Experiment Station (WES) and Fort Worth District (FWD). The Waterways Experiment Station developed design methods for nuclear weapons effects and conducted both full-scale and scale model structural testing. The Fort Worth District built prototype shelters in the Dallas-Ft. Worth area.

Huntsville Division received existing blast shelter literature, coordinated the overall program, and provided completed designs that incorporated the results of the testing and construction program.

A modest \$412,000 was initially authorized for the new mission, but by the end of FY 1984, the introduction of several modifications brought this figure to \$4.9 million.<sup>29</sup>

The first permanent shelter was designed by Huntsville Division in 1983. It could shelter 100 key workers during an emergency, or could be used on a day-to-day basis during peacetime. A prototype shelter was built to provide functional blast protection and provide for dual-use needs. The dual-use features included links to commercial power and water and sewer lines, and contained beam, or column, roof supports combined with removable bunks to provide maximum internal clear space. After the shelter was constructed and successfully tested to withstand design loading, FEMA requested that the Corps design a more austere and cost-effective family of shelters with no special provision for dual use. The final designs of the 50-, 100-, 250-, 500-, and 1000-person shelters were based upon this concept.

The revised 100-person permanent shelter designed by Huntsville Division had concrete inte-

rior walls for roof support without links to external utilities. Based upon the test program conducted by WES, certain cost-reducing elements were eliminated without compromising sound structural performance. The revised shelter was built and successfully tested at White Sands Missile Range (FIG. 13). Similar cost features were introduced in designs for the 50-, 25-, 500-, and 1000-person shelters (Fig. 13).<sup>30</sup>

Huntsville Division also designed two temporary, or transportable, shelters: a 15-person precast concrete shelter and an 18-person corrugated metal shelter (Fig. 14). Both shelters were equipped with bunks, a gasoline-powered ventilation system, and a 14-day supply of food, water, and fuel. One of the shelters was constructed in a shop, trucked to a site, and buried on private property in the Dallas-Ft. Worth area as a prototype.<sup>31</sup>

The number of work years that Huntsville Division estimated on this mission ranged from about 3.5 in FY 1982 to 5.1 in FY 1985. Actual FY 1986 and FY 1987 figures showed a decline in this work to 2.5 and 1.7 work years, respectively.<sup>32</sup>

**Munitions Production Base Support Construction Program (MPBSCP).** Huntsville Division's largest mission was MPBSCP. In 1982, funding for this program was \$54.6 million, which represented about 44 percent of Huntsville Division's total budget.<sup>33</sup> By FY 1988, funding soared to \$112 million, about 40.4 percent of the budget. Each year from FY 1982 to FY 1987 the estimated work years ranged between 50 and 69.<sup>34</sup> By 1983, the program was expected to be completed by 1997.

The purpose of this multibillion dollar program was to upgrade, expand, and modernize the nation's old and somewhat obsolete munitions production

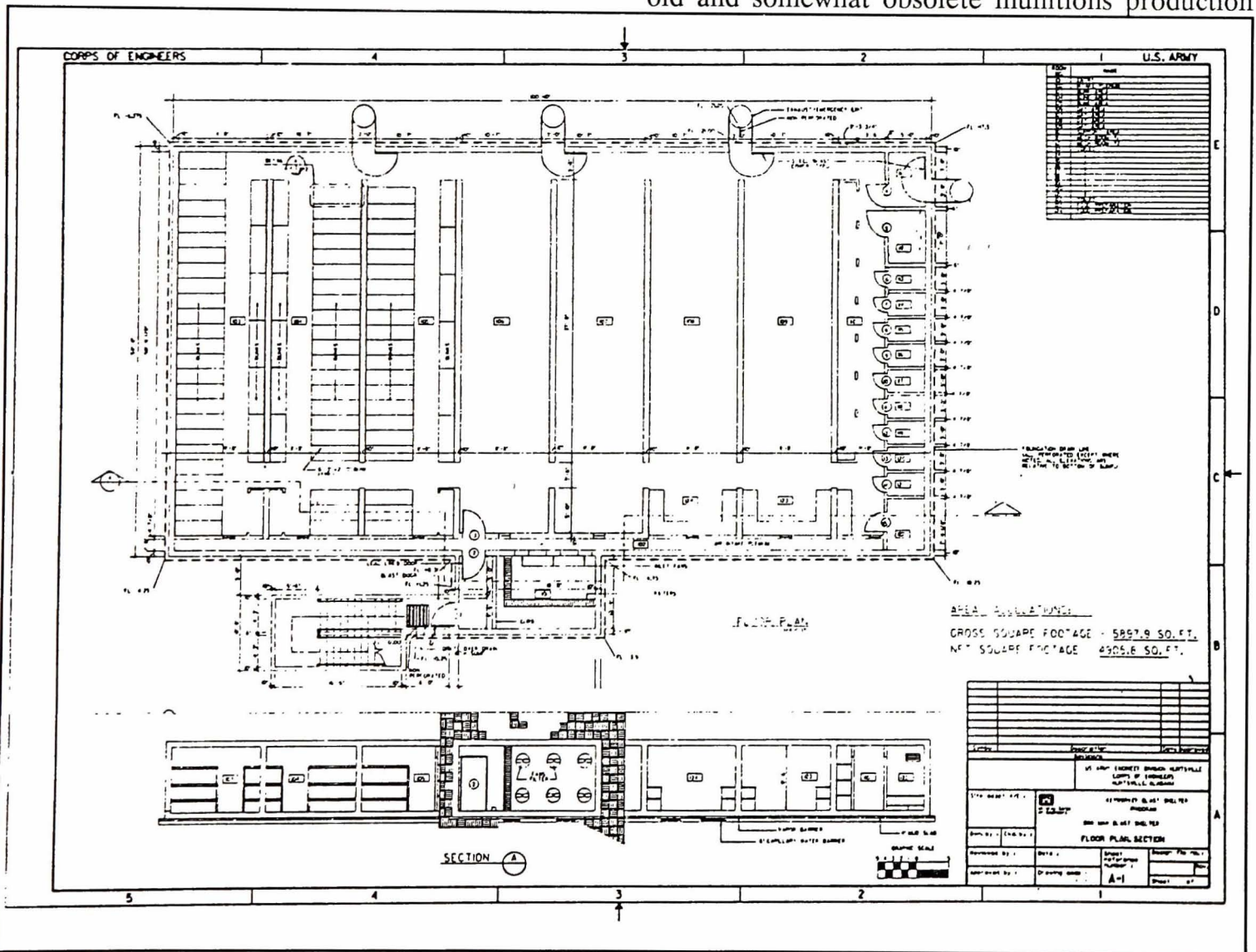

Fig. 13. 500-person FEMA Keyworker Blast Shelter Floor Plan

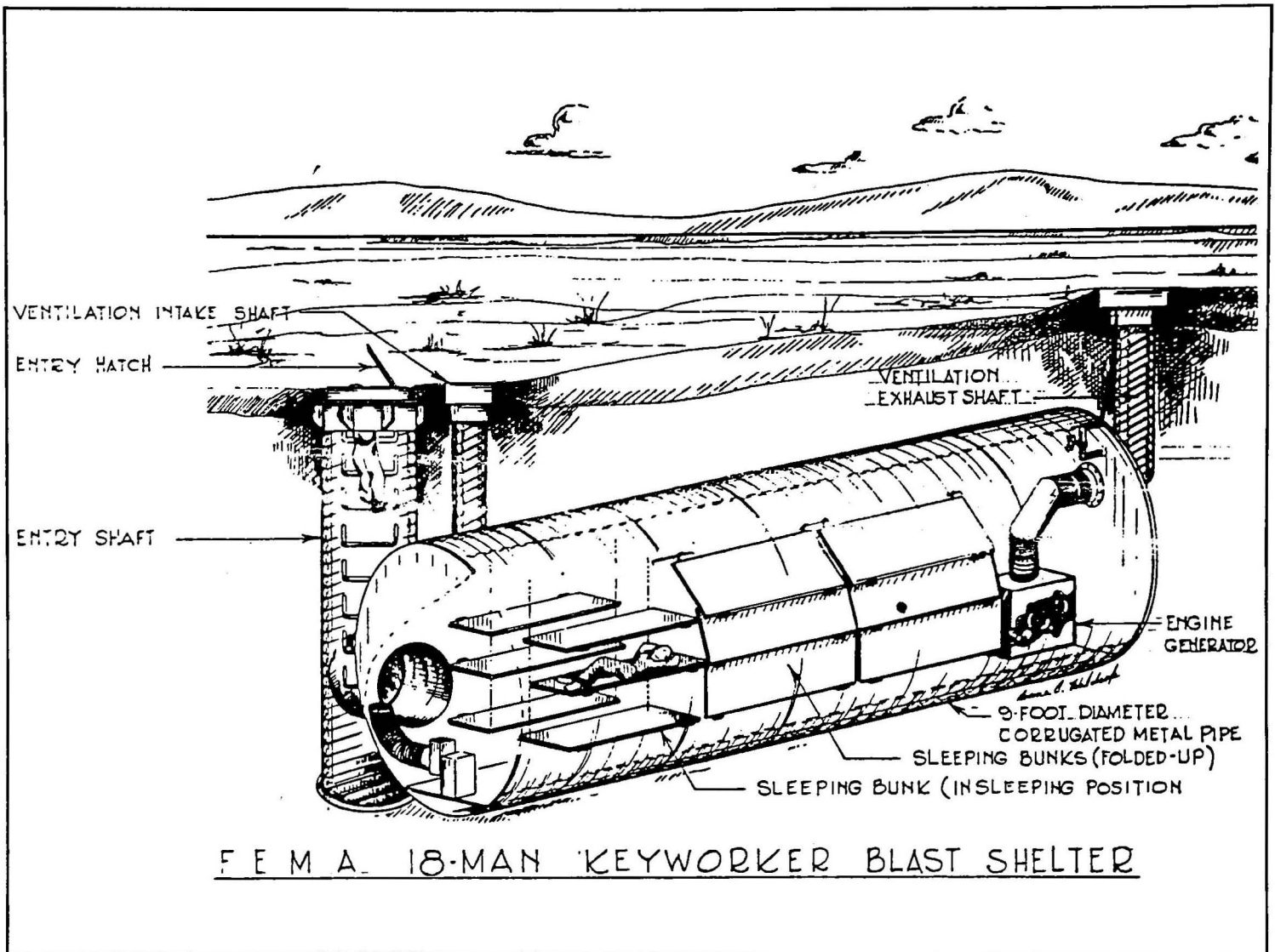

Fig. 14. 18-person FEMA Keyworker Blast Shelter

base. Many of the Army Ammunition Plants (AAP) had become economically unproductive, unsafe, and environmentally hazardous. The long-term goal was to achieve a fully modernized production base capable of meeting both peacetime and mobilization ammunition requirements.

Huntsville Division was assigned the overall Corps management responsibility for MPBSCP, which consisted of two major parts: the Modernization and Expansion Program, and the Production Support and Equipment Replacement Program. The entire MPBSCP was under the direction of the Army Materiel Command Production Base Modernization Activity and involved modernizing 26 government-owned contractor-operated ammunition plants and 5 arsenals (Fig. 15). About one-half of the 26 plants were inactive. Huntsville Division was to design eight

plants, while other Corps districts -- under Huntsville Division's guidance and review -- would design the rest. Safety and environmental concerns received priority consideration under this program. Automation was incorporated whenever justified.

Huntsville Division's role as program manager included planning, scheduling, and reporting; financial management; monitoring designs and construction undertaken by the districts; tasking for designs; reviewing criteria for design adequacy; reviewing and approving cost estimates used for budget submissions; and configuration management. The Division was also responsible for the design of projects for which the process systems were common to two or more existing sites, for new sites, and for technically complex projects.

The major construction work in FY 1982 included

continuation of construction of the 155-MM Improved Conventional Munitions facilities at Mississippi AAP and the Continuous Automated Multibase Line facility at Radford AAP.

Finished in 1984 at a cost of \$493 million, the Mississippi AAP was the first completely new AAP to be built since World War II (Fig. 16). The cost of construction was \$180 million, and the balance paid for equipment and other related materials. It was the largest single effort in the MPBSCP up to that time.<sup>35</sup> Because of the size of the project, it was divided into

several design and bid packages. The following table shows the magnitude of some of the larger construction packages:

**Table 5**  
**Mississippi AAP Major Construction Contracts<sup>36</sup>**

Projectile Metal Parts Facilities	\$47,261,480
Cargo Metal Parts Facilities	15,434,626
Lap 300 Area	31,027,228
Other support facilities (multiple contracts)	175,866,174

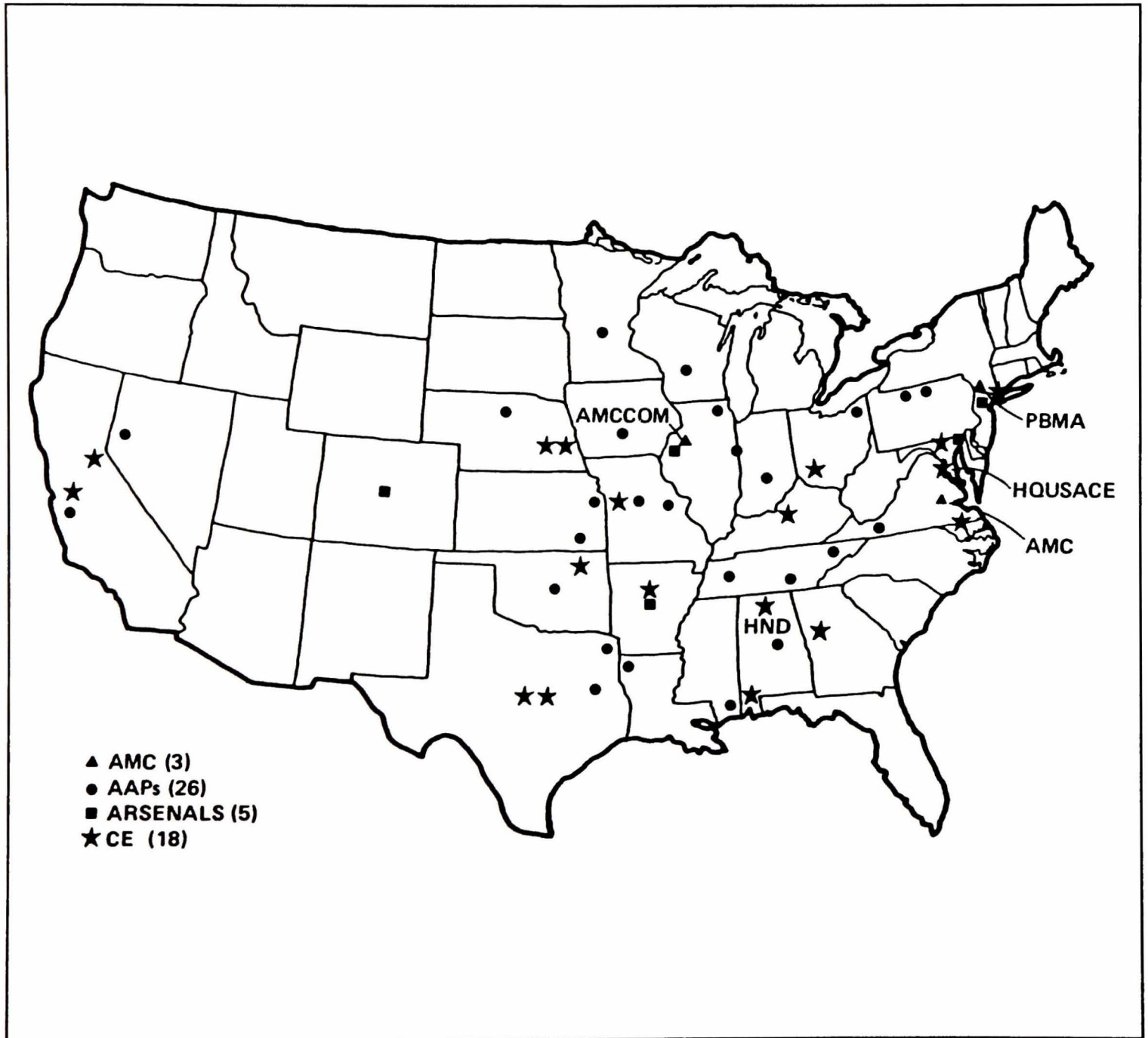

Fig. 15. Corps of Engineers Support to Munitions Production Base Support Program

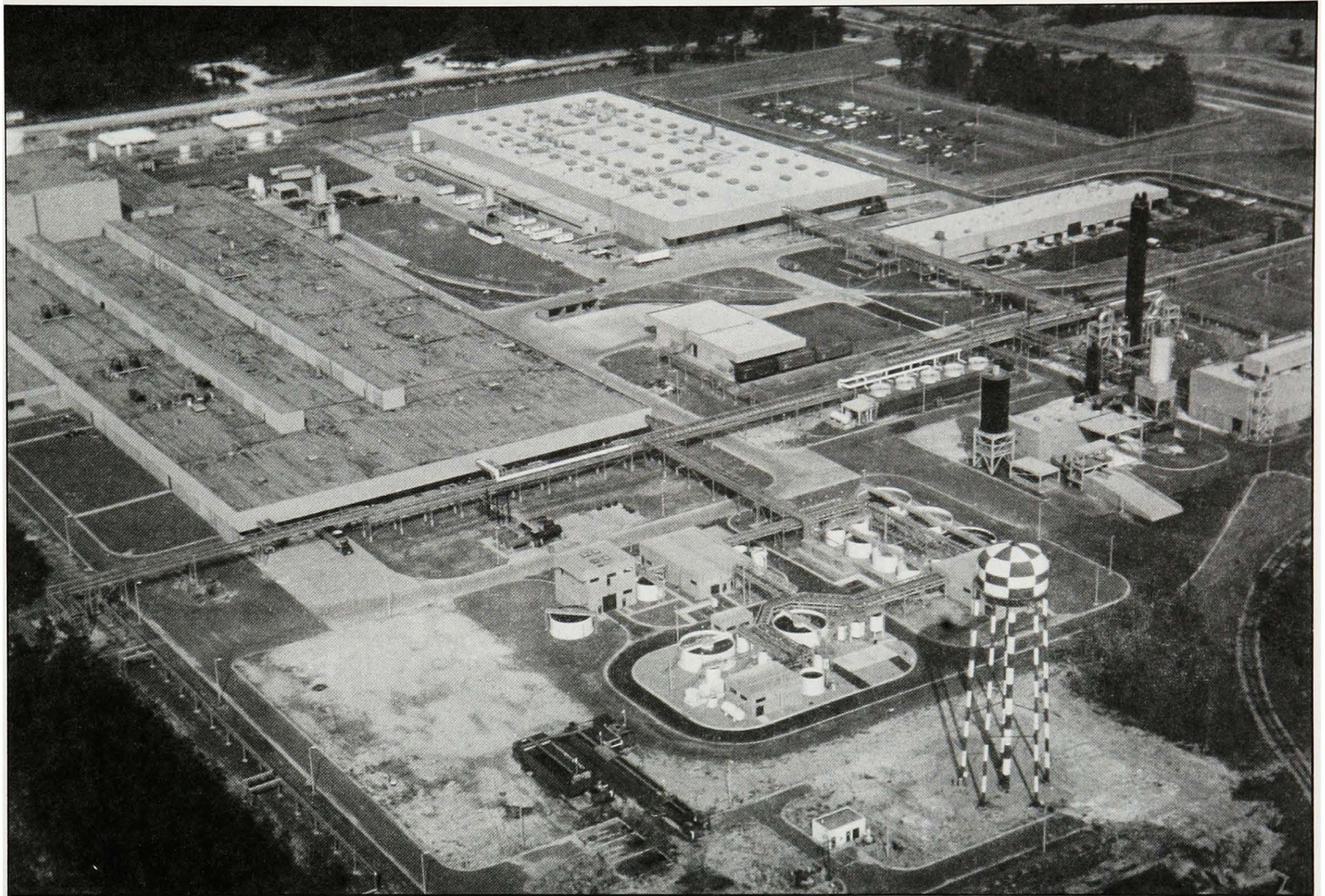

Fig. 16. Mississippi Army Ammunition Plant Under Construction, November 1983

Huntsville Division designed the new plant, awarded all construction contracts, and assisted the Mobile District in executing the construction. The overall facility included a projectile and cargo area; metal parts manufacturing buildings; a loading, assembling, and packing (LAP) area; and other essential supporting facilities for production. Criteria development was performed by Kaiser Engineers. The actual design of the LAP area and structural system was done by Hayes, Seay, Mattern, and Mattern under an A-E contract with the Division.<sup>37</sup>

During this period emphasis also was placed on providing Containerized Distribution Facilities (CDF) for certain ammunition plants. Construction of one CDF was completed and another begun. Two additional CDFs were also ready for construction and six more were being designed during this period.<sup>38</sup>

A major offshoot of the MPBSCP in which Huntsville Division was involved was the RDX/HMX

Expansion Program. The Division's responsibility was to design new facilities for the improved production of RDX/HMX. RDX is a sensitive explosive with about twice the destructive power of TNT. With the addition of wax, TNT, or steric acid, RDX becomes a conventional explosive. HMX is a by-product of the Bachman RDX production process. Government-sponsored research during 1978-1987 resulted in the MUSALL process, a new and innovative method by which HMX is produced. HMX has greater destructive power than RDX and is used primarily in missile warheads and motor propellants.

Holston AAP was the sole plant that produced RDX and HMX. A study of the production process and output of these explosives at Holston AAP revealed that the plant had the capability of producing much more explosive than it was producing. Huntsville Division's goal was to increase production by designing and constructing better facilities. The scope of its responsibilities included the construction

of new facilities at four AAPs in Louisiana, Illinois, Indiana, and Iowa.

With an appropriation of \$360 million, Louisiana AAP was to become the first plant to have new facilities constructed under this program. In addition to the four plants, a MUSALL processing HMX plant was being planned for an undetermined location.<sup>39</sup> In September 1986, Huntsville Division awarded a \$15 million A-E contract to Stone and Webster Engineering Corporation of Boston to prepare the technical portion of a Request for Proposal for the design and construction of a RDX facility at Louisiana AAP that would produce 2.5 million pounds a month. The facility was to be built in FYs 1988-1992.<sup>40</sup>

## Army Readiness

**Army Training Range Program.** In the fall of 1981, HQUSACE designated Huntsville Division as the Range Center of Competence to support the U.S. Army Training and Doctrine Command (TRADOC) and the Forces Command (FORSCOM) in standardizing range facilities and providing design guidance to Corps districts.<sup>41</sup> The program was funded annually between \$682,000 and \$5.45 million during the period of this history. Estimated annual work years ranged from 12 to 27.8.<sup>42</sup>

The program arose from dissatisfaction with training ranges. It was designed to increase the training value of range firing, while decreasing the overall cost of range construction and maintenance. To ensure the success of the program, management and responsibility were centralized at TRADOC and its Directorate for Army Ammunition, Ranges and Targets (DAART). Huntsville Division entered into a Memorandum of Understanding with DAART to provide technical assistance in the range program, assistance that was to include the development of maximum standardization in range equipment, instrumentation and controls, and facilities. In addition, the Division was to provide input into the 1391 Processor System and project development brochures, prepare standard drawings and specifications, and review concept designs prepared by Corps districts.<sup>43</sup>

FY 1984 marked the beginning of actual construction of standardized ranges. The program involved three types of ranges. One was the basic rifle

marksmanship range. A second was the multipurpose range used at infantry facilities designed to reduce real estate requirements and provide more realistic training. This type of range enabled different weapons systems to be used simultaneously. The third type of range was for military operations in urbanized terrain (MOUT).

Construction of multipurpose ranges was begun at Fort Hood (Texas), Fort Riley (Kansas), and Fort Bliss (Texas). Construction of ten infantry ranges, including automated record firing and automated field-fire ranges, was begun at three installations.

A MOUT range was built at Fort Bragg, North Carolina, which was used as a prototype in the Range Standardization Program. Additional ranges of various types were in the planning and design stages for FY 1985 and beyond.

Huntsville Division developed design guide manuals for each of the three types of ranges. The manuals provided Corps districts with design information on standard features and design guidance on the essential interface details between the civil work and the target systems.<sup>44</sup>

The Division also devised a system using computer graphics for the site-specific design phase. Techniques such as these were expected to greatly assist districts in their range designs and to expedite the planning, programming, and design process. Huntsville Division was also responsible for reviewing designs for compliance with target equipment interface requirements and standardization.<sup>45</sup>

The year 1986 witnessed significant progress in several areas of the program. Several improvements resulted from incorporating "lessons learned" into new or revised design guides that were provided to the field.

The first standard range complexes built in accordance with Huntsville Division's design guides were completed that year: a MOUT complex at Fort Pickett, Virginia, and a multipurpose range complex at Fort Bliss, Texas.

The Division also designed tank ranges for the U.S. Marine Corps at Camp Pendleton and Twentynine Palms, California. The designs reflected an accommodation to both new weapons systems and changes in battle concepts.<sup>46</sup> In 1987, Huntsville Division was designated the Training Range Mandatory Center of Expertise.<sup>47</sup>

# High Technology Facility Support

## Environmental Programs

For several years both Congress and the Environmental Protection Agency criticized the Armed Forces for environmental problems in and around installations. Pollutants were created by the production and use of weapons and ammunition and by other activities generally associated with the military. As late as 1988, government officials observed that hundreds of military sites were violating a federal law that governed the handling and disposal of hazardous substances. However, pollution was not endemic to the military alone, but was a problem pervasive throughout all elements of society. Moreover, any corrective action to a problem that had been permitted to fester for decades could not be solved overnight; corrective measures would have to be long term, and unfortunately, resources available for pollution control were limited.

Nevertheless, the pollution problem was serious enough that federal, state, and local governments passed laws mandating the cleanup of military installations. The federal government led the way, with Congress passing 16 new laws and the administration issuing Executive Orders. Those studies were followed by state and local laws, Department of Defense (DOD) directives, and Army regulations -- all of which defined environmental requirements. One federal law, the Resource Conservation and Recovery Act (RCRA), listed more than 250 specific demands that were auditable.<sup>1</sup>

Huntsville Division's involvement with environmental missions dates back to the adoption of the Clean Air Act Amendment of 1977 and the Clean Water Act of 1977, both of which directed federal agencies to comply with federal, state, and local pollution abatement laws.<sup>2</sup> It was inevitable that Huntsville Division would become involved in environmental causes because of the numerous pollution requirements and the growing engineering technology in the field of environmental preservation. To end violations of the Clean Air Act and the Clean Water Act, and concurrent with Corps of Engineers'

mandate to implement those acts, Huntsville Division was assigned centralized and standardized management of the Army's Pollution Abatement Program (APAP) in March 1978. Huntsville Division and Corps districts were to survey installations by September 1978 in order to identify unreported sources of pollution and establish corrective measures. Of 144 installations surveyed, 116 were found to be in violation of the law.<sup>3</sup>

The responsibility for complying with the law rested with each installation and its major command, but the Corps of Engineers had the authority to assist them. Most of the support was furnished on a non-reimbursable basis, until FY 1982, when support became reimbursable. Meanwhile, Huntsville Division was designated as a Center of Competence for the APAP. Since Huntsville Division was the central manager for all pollution abatement projects designed by field operating agencies (FOA), FOAs, major commands, and installations were required to work with Huntsville Division on all matters regarding potential pollution sources. Surveys identifying the specific pollutant were generally conducted by the U.S Army Health Services Command with assistance from Huntsville Division and the Corps districts.<sup>4</sup>

Between 1978 and 1982 Huntsville Division completed 248 studies at a cost of \$4.9 million. During that same period, districts built 155 Military Construction Army (MCA) projects costing \$360 million. Of the 116 installations that were found to be violating the regulations in 1978, more than 100 were brought into compliance by 1984.<sup>5</sup>

As environmental technology grew, some programs were abandoned, new ones were introduced, and others modified or merged. Huntsville Division's responsibilities changed accordingly. They encompassed not only air and water pollution, but hazardous and toxic waste, unexploded ordnance in and near present and former DOD installations, and abandoned structures and debris. The object was to make installations safe and clean. The Army Pollution Abatement Program became one of the largest

programs administered by Huntsville Division during the period of this history.<sup>6</sup> Furthermore, the Division became involved with the demilitarization of chemical weapons -- an extremely hazardous activity that had national and international implications. Because of its unique and profound significance, the chemical demilitarization program has been covered in a separate section.

Most of the environmental deterioration occurred at installations where weapons and ammunition were researched, tested, manufactured, and stored (that is, arsenals, proving grounds, Army ammunition plants, and depots). The Army Materiel Command (AMC) was responsible for these installations. The Army Materiel Command, formerly DARCOM (Development and Readiness Command), became Huntsville Division's biggest environmental customer, but not the only one. Other major organizations such as the Defense Logistics Agency also sought the Division's assistance.

Huntsville Division's capabilities in both environmental cleanup and chemical demilitarization complemented each other. As the toxic waste cleanup effort increased nationwide, the Division's technical capabilities were increasingly sought. The Division's large reserve of engineers specializing in pollution abatement problems, augmented by a HQUSACE engineering capability and a well-recognized contracting capacity, provided a responsive team.

In 1982, a new environmental program was given to Huntsville Division. Under the AMC Resource and Conservation Act of 1976, the Division would provide centralized management and technical support for AMC's pollution abatement studies. The Division would conduct groundwater assessments at AMC installations and undertake an assortment of air and water pollution studies. In addition, Huntsville Division would provide design review support whenever necessary. Those kinds of studies and assessments were conducted at installations where confirmed contamination existed and were based upon results of groundwater sampling undertaken by the U.S. Army Environmental Hygiene Agency.

At first the funding ceiling for Huntsville Division's participation in AMC's pollution abatement studies was estimated at \$15 million for FYs 1982 and 1983. However, the actual figure was reduced to \$3 million for each of those years, but by 1986, funds exceeded \$12 million.<sup>8</sup>

As part of its responsibilities, Huntsville Division

would enter into contracts to have installations audited. An audit report was prepared for each of AMC's 65 active installations. This included an installation questionnaire, and an audit team visit to review documents, inspect environmentally significant operations, and determine the effectiveness of the environmental staff and local policies. The report that resulted from that visit assessed the installation's performance in complying with the Army's program.<sup>9</sup>

In December 1981, the U.S. Army Toxic and Hazardous Materials Agency (USATHAMA) requested Huntsville Division's assistance in the Installation Restoration Program. That environmental program was also related to AMC support. Its purpose was to assess and clean up hazardous and toxic contamination of groundwater that was seeping from the installation into lands near the perimeters.<sup>10</sup>

Together, USATHAMA and Huntsville Division were to conduct studies, identify and characterize waste, determine the corrective action to take, and develop criteria and programming documentation. Corps divisions and districts were to design and clean up facilities when necessary. Huntsville Division's first project was the Anniston Army Depot in Alabama where a \$5.2 million contract was awarded to Roy E. Weston, Inc. in 1982. The contractor removed wastes resulting from degreasers, cleansers, and other contaminants (Fig. 17). The contractor then transported the waste to an approved hazardous waste dump in Emelle, Alabama. The Mobile District supervised the contract.<sup>11</sup>

In 1986, Huntsville Division awarded and managed a contract to complete the surface clearance of 943 acres of land at Hawthorne Army Ammunition Plant in Nevada. That contract was the first ever to be awarded by the Corps of Engineers for the collection and disposal of unexploded ordnance, since military personnel normally performed surface clearance on Army installations. A significant event of that surface clearance project was an agreement between the United States and Canada. Huntsville Division was to exchange information about explosive ordnance contracts with Canada's National Defense Headquarters. The agreement was successful, providing Huntsville Division with invaluable experience. From that experience the Division learned that good rapport was essential between the contractor and the Corps, both parties needed more time to assess the character of the contamination, detailed screening of the local labor market was needed, the forecasting of

climate conditions was important, frequent safety briefings would help prevent accidents, and that adequate time was essential to complete work with the available labor force. As a result of the Hawthorne cleanup, Huntsville Division concluded that it was feasible to do such a project under civilian contract.<sup>12</sup>

In December 1983, Congress enacted Public Law 99-212, which provided the means for restoring former DOD properties. The Department of Defense was to identify, investigate, and clean up former DOD installations contaminated by hazardous substances and wastes, correct other environmental damage, demolish and remove unsafe and unsightly buildings and structures, and seek improvements in hazardous waste disposal.

In March 1984, Huntsville Division was assigned the inventory phase and engineering for ordnance disposal of the Environmental Restoration Defence Account (ERDA). That assessment involved compiling an inventory of former DOD properties that either posed a hazard or were unsightly because of deteriorated structures and debris, toxic waste, and abandoned ordnance and munitions. When Huntsville Division assumed the program, a Department of the Interior list contained several hundred former DOD sites. By August 1985, the Division had identified 5,630.<sup>13</sup>

One year after the program was in effect, ERDA became the Defense Environmental Restoration Program (DERP). Soon, Huntsville Division assigned FOAs to conduct 895 inventory site surveys. Of those, 112 were found to have debris problems, and two sites had toxic and hazardous waste problems. By August 1985, there were 23 architect engineer (A-E) investigations of hazardous toxic waste projects underway plus investigations at former NIKE missile sites.<sup>14</sup>

By mid-1987, the inventory of sites had reached 7,500. The Defense Environmental Restoration Program now included both former and active DOD sites and installations.<sup>15</sup> The Installation Restoration Program was placed under DERP. By the end of 1987, the Corps of Engineers was conducting surveys, establishing priorities, and determining DOD responsibilities for environmental restoration. An interactive data base was developed and placed into operation. Corps districts were directed to survey about 500 sites each year. The following table summarizes the status of the inventory between January 1986 and January 1988:

**Table 6**  
**DERP Site Surveys<sup>16</sup>**

	Jan. 1986	Feb. 1987	Jan. 1989
Sites identified	6449	7164	7114
Sites tasked	963	2181	2641
Eligible debris sites	n/a	110	116
Eligible hazard toxic sites	n/a	18	56
Eligible ordnance sites	n/a	2	2
Negative sites	n/a	423	539
IPRs submitted to HQUSACE	446	595	758

During the site surveys, evidence was gathered to determine whether the sites were contaminated with hazardous wastes. If the site was suspected of being contaminated, a confirmation study was conducted to determine the presence or absence of contaminants. Originally, Huntsville Division was responsible for managing all confirmation contracts. In FY 1986, the Division developed a plan to decentralize those studies so that the FOAs would be more directly involved with them. One district within each division was to manage confirmation studies for the whole division. Since not all divisions were able to manage the studies because of other work load commitments, adjustments were made between divisions that could manage the work load. Thus, Huntsville Division was relieved of much of the responsibility for managing confirmation study contracts. The following table reflects the confirmation studies undertaken in 1986 and 1987:

**Table 7**  
**Confirmation Studies<sup>17</sup>**

	Jan. 1986	Feb. 1987	Oct. 1987
Studies underway	26	69	175
Studies completed	5	25	39
Backlog	n/a	77	55

By the end of 1987, of all the sites eligible for restoration, only two sites contaminated with abandoned ordnance remained.<sup>18</sup>

In addition to the support given to DOD in this major area of installation restoration, Huntsville Division also provided DERP support to a number of Defense Logistics Agency (DLA) installations. The Defense Logistics Agency consists of seven principal distribution depots that receive, store, and issue supplies common to all military installations, other

DOD agencies, and federal agencies. A 1985 Memorandum of Understanding between HQUSACE and DLA established that Huntsville Division was to serve as the single point of contact within the Corps for the DLA's groundwater quality and contamination assessment and hazardous waste remediation efforts.<sup>19</sup>

As a result of this agreement between HQUSACE and DLA, Huntsville Division became involved in eight projects, seven of which were defense depots. For that work, \$3 million were provided in funds from the time the program was first assigned until 1988.<sup>20</sup> One of the projects, Defense Depot Ogden, in Utah, required immediate attention. It had been among the few installations designated on the National Priority List of the Most Hazardous Sites in the United States. The depot was suspected of containing remnants of mustard gas in the soil. By 1988, work at the depot was progressing satisfactorily.<sup>21</sup>

Another environmental program in which Huntsville Division played a major role was the Defense Reutilization and Marketing Service -- Conforming Storage Program. That program was designed to support the Defense Reutilization and Marketing Service (DRMS), which was part of DLA. The Defense Reutilization and Marketing Service is responsible for the disposing of excess DOD properties, including hazardous wastes. The storage of hazardous wastes for more than 90 days required specially designed structures conforming to the provisions of the Resource Conservation Act. Because DRMS was behind in its attempts to build such facilities, it requested Corps of Engineers assistance. A 1985 Memorandum of Agreement made Huntsville Division the agent for designing and constructing minor structures on all DRMS storage facilities within the continental United States. Other agreements were later signed, bringing in the assistance of Corps divisions. Huntsville Division was to produce the specific building design drawings and specifications for 57 projects. It then made them available to 14 Corps districts selected by the divisions for on-site work design, site adaptation, bid preparation, and construction contract award.<sup>22</sup>

By the end of 1987, Huntsville Division prepared 12 different floor-plan variations of the standard design and was in the process of producing 48 building designs for site adaptation by Corps districts and A-E firms. The status of the 57 projects by the end of 1987 was as follows:

**Table 8**  
**Status of DRMS Program in 1987<sup>23</sup>**

Constructed	0
Awarded/Under construction	6
IFB issued	1
100% design completed	14
90% design completed	19
35% design completed	9
Awaiting tasking letters	9
<b>Total</b>	<b>57</b>

## Chemical Demilitarization Program

The Chemical Demilitarization Program began in the late 1960s when the Department of the Army directed that certain obsolete and excess chemical munitions be destroyed in an ecological and safe manner. The disposal of M34 cluster bombs at Rocky Mountain Arsenal in the early 1970s provided the basic technology and experience for destroying chemical agents on a production level. The technology acquired was then employed in the development of the Chemical Agent Disposal System (CAMDS) pilot facility at Tooele Army Depot in Utah and in the design of the Chemical Agent Identification and Training Sets disposal facility that began operations at Rocky Mountain Arsenal in 1982. The Chemical Agent Disposal System facility at Toole was capable of disposing of all types of chemical munitions, but its main weakness was its limited capacity.

Therefore, in the full-scale demilitarization program, obsolete chemical munitions, and ultimately the entire stockpile, were to be destroyed in fixed disposal systems located at selected sites within the continental United States and at Johnston Atoll in the Pacific.<sup>24</sup> At those selected sites, two types of lethal chemical agents -- nerve and blister -- were configured in a variety of munitions and bulk containers. Fig. 17 shows the location of the eight CSDP sites and the type of chemical munitions stored at each site.<sup>25</sup>

In 1981, Huntsville Division agreed to provide USATHAMA with engineering support for the re-

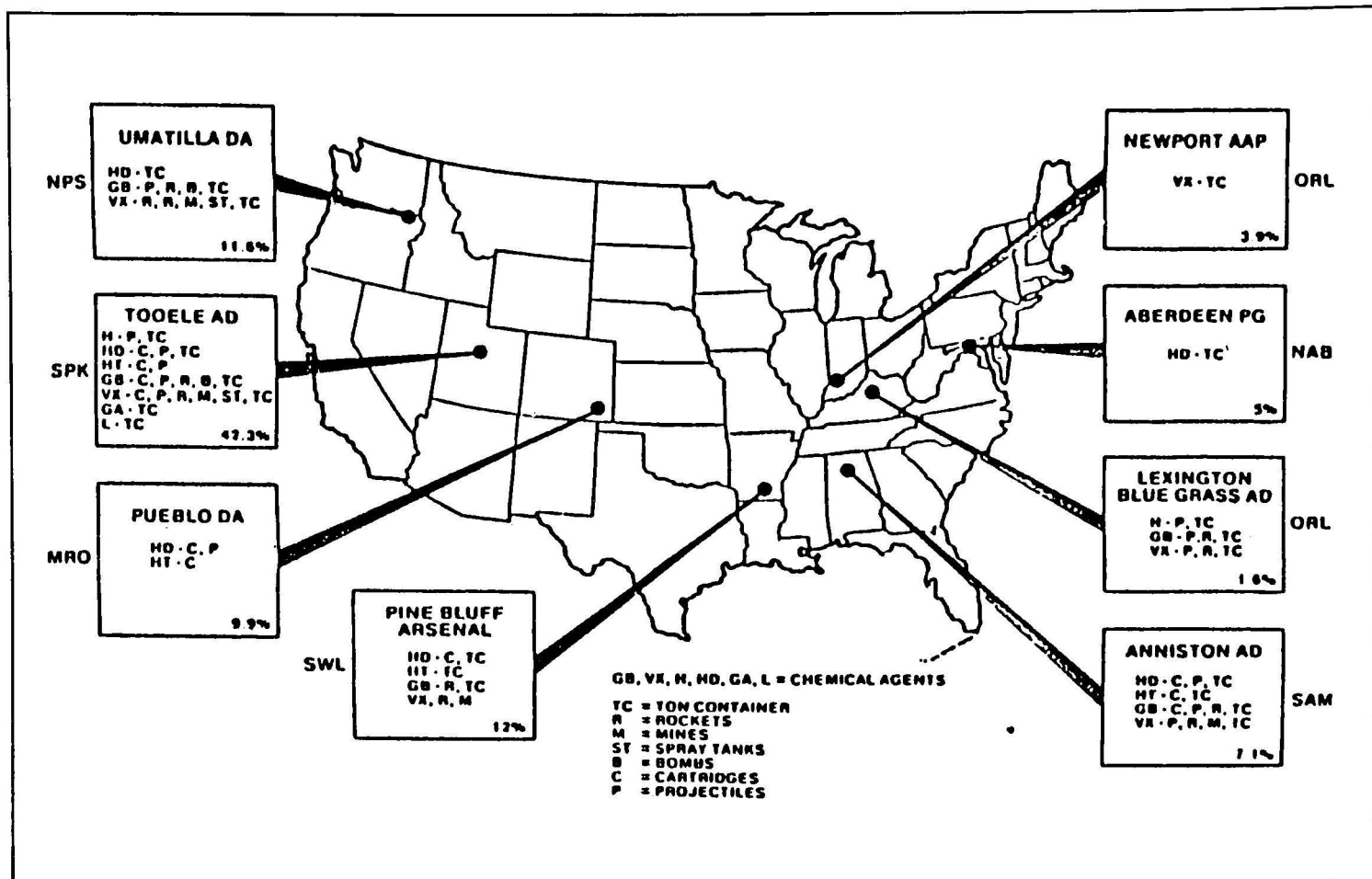

Fig. 17. CONUS Chemical Stockpile Storage Sites

search and development of the long-range disposal program and contracting support for the CAMDS operation. A later agreement between the two parties added the BZ Disposal Facility at Pine Bluff Arsenal to Huntsville Division's responsibilities. The long-range objective of the agreements was to develop, design, construct, and operate multiple facilities for the disposal of the entire existing stockpile of lethal chemical weapons. The short-range objective was the continued operation of the CAMDS facility at Tooele Army Depot in order to demonstrate and improve existing technology, design and construct a prototype chemical demilitarization facility at Johnston Atoll (Fig. 18) in FY 1985, and continue basic research and development in the hopes of achieving a more cost-effective solution to the demilitarization problem.<sup>26</sup>

From the pilot program begun at Tooele Army Depot in 1982, the Chemical Demilitarization Program grew rapidly. Huntsville Division managed the engineering and contracting for Tooele. Three companies were awarded contracts in mid-1982 for a total of \$2.4 million to research and develop an efficient and economical mechanical process for demilitariz-

ing chemical munitions. Phase I, during which the contractors were to be involved, covered an eight-month investigation of chemical demilitarization systems, including an industry and literature search for applicable new technology, an engineering evaluation of the new technology, and preparation of demilitarization concept proposals for a mechanical processing system. Once Phase I was completed, the government was to select the concepts that were to be developed and tested by the contractor in Phase II of the program. Phase II would take 22 months and consist of laboratory benchscale feasibility demonstrations of the Phase I concepts.<sup>27</sup>

As part of Phase I, Huntsville Division was to design a chemical demilitarization facility on Johnston Atoll, employing currently available technology. That responsibility was to be shared with the Pacific Ocean Division in accordance with a Memorandum of Understanding signed in 1982.<sup>28</sup>

Facility criteria development for Johnston Atoll Chemical Agent Disposal System (JACADS) was completed under contract. The process system design

was begun in August 1982 under contract to the Ralph M. Parsons Co. of Pasadena, California. Other contracts in support of the project were awarded to Maxima Corporation of Bethesda, Maryland, for management information system services and to the MRC Division of Chamberlain Corporation for mechanical engineering services. The long-range research and development contracts completed the first phase of the conceptual development program for Johnston Atoll.<sup>29</sup>

Construction at Johnston Atoll, which was part of Phase II, was estimated to cost \$74 million. During the initial stages of the project, Huntsville Division received about \$10 million for central management.<sup>30</sup> Construction began in FY 1985.

By the end of FY 1984, Huntsville Division completed 90 percent of the final design on JACADS, and it also started procuring items for the BZ facility at Pine Bluff Arsenal. An agreement that would provide

selective procurement support for the CAMDS facility at Tooele Army Depot was also reached.<sup>31</sup>

In 1984, a \$50.5 million contract was awarded to the Stearns Catalytic Corporation of Denver for the purchase and installation of process equipment for JACADS. Equipment installation began in 1986. In order to coordinate engineering support during construction, installation of equipment, and start-up, Huntsville Division established a liaison office in Honolulu. In the meantime, the Pacific Ocean Division awarded a \$32.8 million construction contract in September 1986.<sup>32</sup>

The JACADS facility represented a vastly different kind of operation from the days when munitions were demilitarized at Rocky Mountain Arsenal. The new facility was operated by robots and computers, with workers observing operations via television. The facility building itself consisted of a 73,000-square-foot demilitarization building and

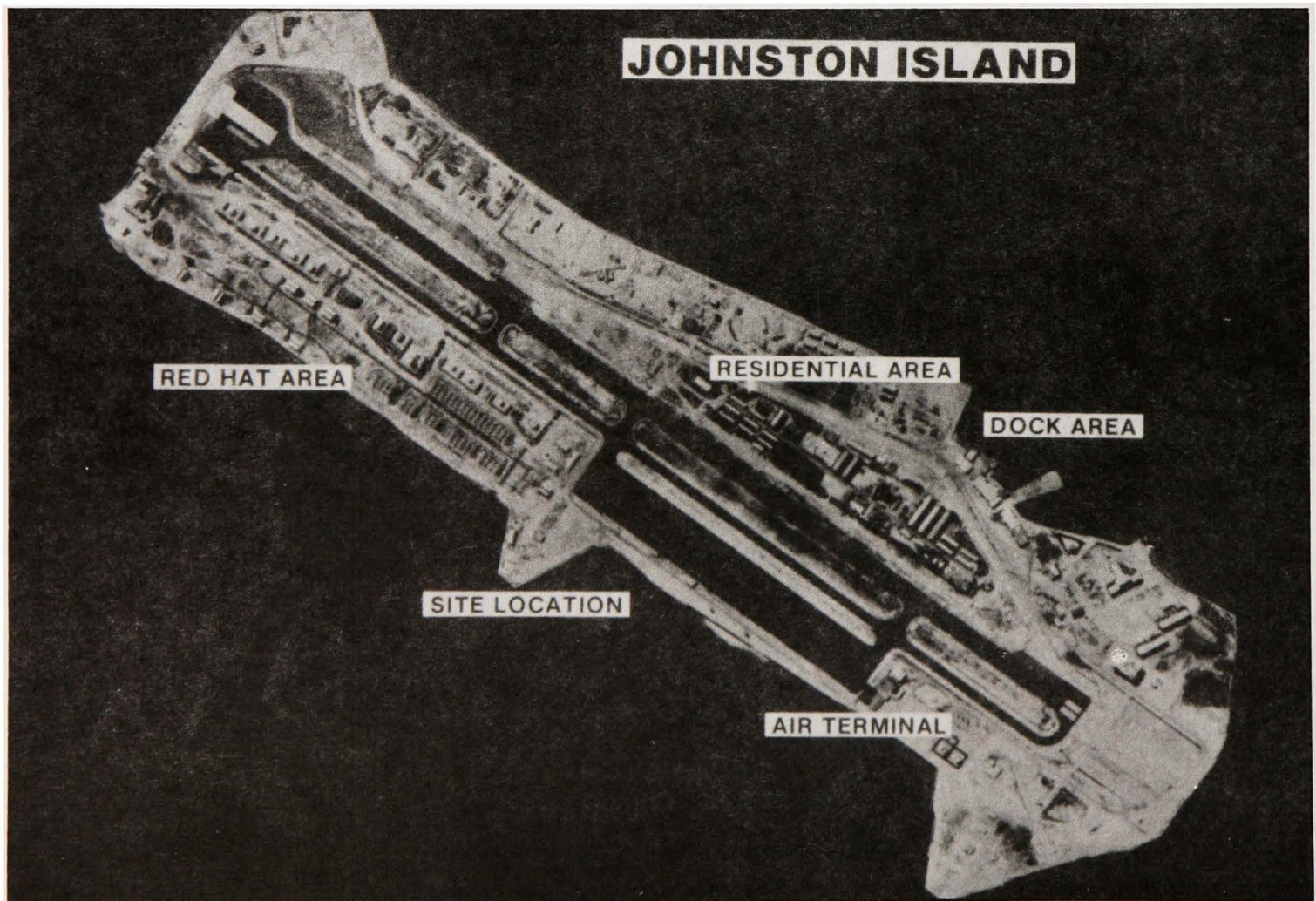

Fig. 18. Aerial View of Johnston Island



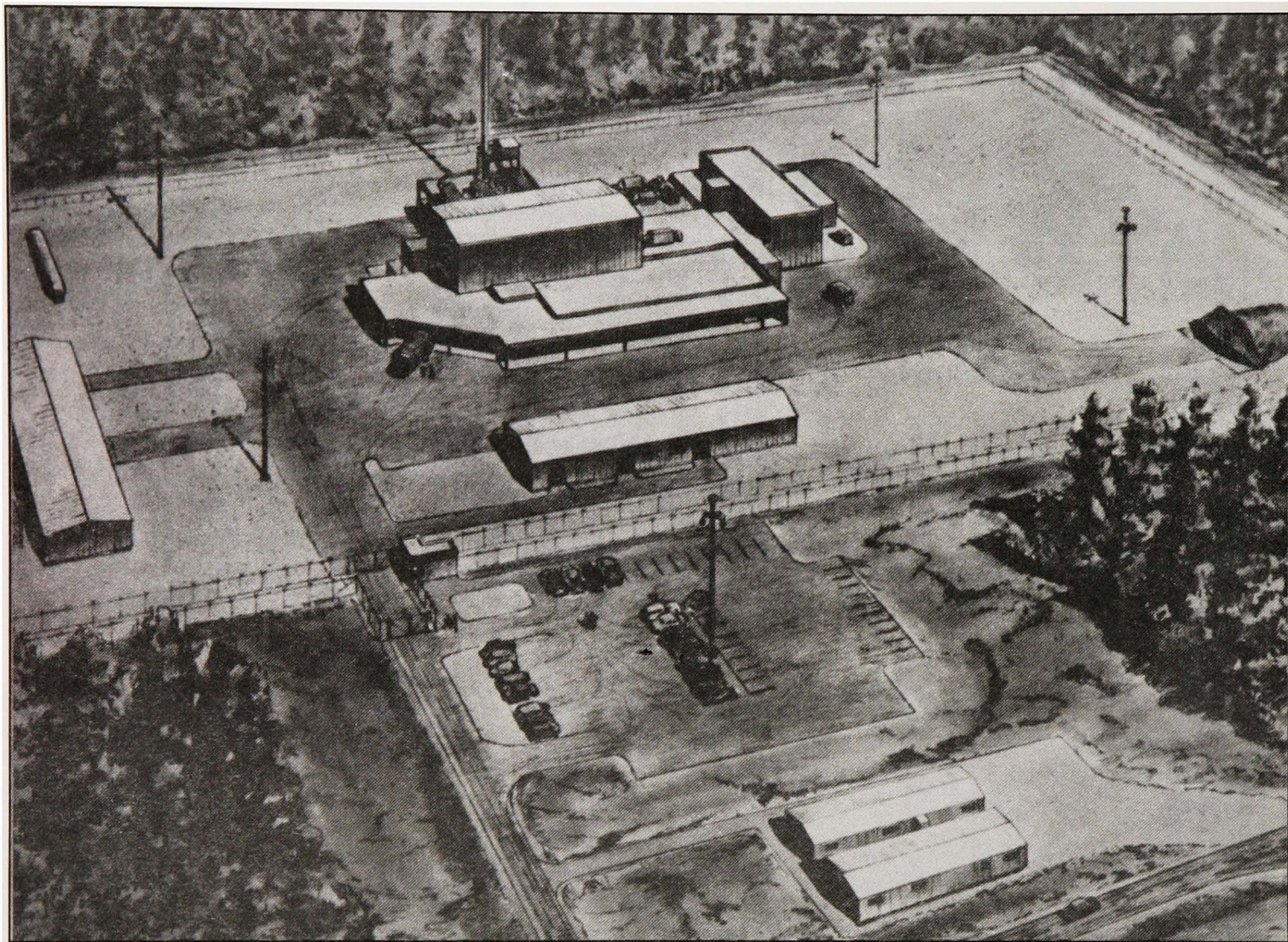

Fig. 20. Artist's Concept of BZ Facilities at Pine Bluff, Arkansas

design, construction, and installation of equipment at three demilitarization plants for the M55 Rocket and M23 Land Mines at Umatilla Army Depot in Oregon, Lexington Blue Grass Army Depot in Kentucky, and Anniston Army Depot in Alabama.<sup>35</sup>

By the end of 1987, Huntsville Division was in the process of designing eight plants in the United States, using the concepts employed at JACADS. Basically, the concepts included separate buildings for each process in the destruction of ammunition and chemical agents at the same location they were stored, thereby avoiding the risks of transporting hazardous chemicals. Huntsville Division designed the facilities and the process system and awarded the contract, but Corps districts supervised construction under the general management of Huntsville Division.<sup>36</sup>

In March 1987, the Department of the Army submitted its first Chemical Stockpile Disposal Program Concept Plan (CSDPCP) to Congress in accordance

with the Department of Defense 1986 Authorization Act. The plan outlined a system for disposing chemical munitions located at the eight sites by September 1994 as mandated by Public Law 99-145. An updated version of that plan contained three options for destroying the chemical stockpile: on-site destruction, transporting chemical munitions from one of two regional sites to the other for destruction, and transporting chemical munitions to a single national disposal site. In February 1988, the CSDPCP Final Programmatic Environmental Impact Statement was issued, recommending that the preferred alternative was on-site destruction. In the meantime, the date for completing the chemical stockpile disposal was changed from 1994 to 1997, and the destruction of these weapons was to begin in either 1992 or 1993.<sup>37</sup>

The selection of on-site destruction of chemical munitions tended to allay the concerns of many who feared that the transportation of chemical munitions

through their states would be extremely dangerous. States such as Kentucky had already passed legislation restricting the passage of chemical munitions through the state. However, strong opposition in some local communities like Baltimore, Maryland, and Lexington, Kentucky, persisted. Those communities were adjacent to the Aberdeen Proving Ground and the Lexington Blue Grass Army Depot where demilitarization of chemical munitions was to occur.<sup>38</sup>

## SPECBASE

SPECBASE, formerly known as EDITSPEC, consisted of a system of computer programs for editing selected specifications in order to tailor them to a specific project. By the end of 1981, Huntsville Division made considerable progress in deploying an operating SPECBASE module.<sup>39</sup> In 1982, the first users of EDITSPEC were "on line" in that program. Adding to the training already provided in December 1981, two more courses were held in February and March 1982. By April 1982, 19 FOAs were using EDITSPEC. During FY 1982 the system was extended to all Corps divisions and districts having military construction as part of their mission. An initial orientation on the system's use and capabilities was given to each division and district during which time 260 engineers and managers attended. Three EDITSPEC operator training courses, at which time 45 persons received training, were also conducted.<sup>40</sup>

After consulting with FOAs, in 1984, HQUSACE decided to reduce the scope of EDITSPEC to what then became known as SPECBASE. Opinions from the Corps districts led to the recommendation to restructure EDITSPEC. Headquarters believed that once SPECBASE was tested and in operation, because of the way the data was structured, it would take little research and development to consider automatic generation. Colonel Poteat indicated his concern over the decision to abandon EDITSPEC in favor of a more modified SPECBASE module that eliminated the automatic generation of specifications, a factor which he believed was of significant advantage to the Corps. Nevertheless, he was content to learn of the initiatives already taken to enhance the technical knowledge that was gained during the operation of EDITSPEC. Colonel Poteat hoped that

the Corps would exploit this knowledge and provide the FOAs with some kind of automatic generation of specifications in the near future.<sup>41</sup>

Like its predecessor, SPECBASE was a system that distributed Corps of Engineers specifications. It was managed by the Division's Engineering Support Branch with analysis, programming, word processing, and data entry from the Information Management Office. The central computer used was the Control Data Corporation's CYBERNET Computer Service. Through CYBERNET, guide specifications were made available to Corps users, A-E firms, and others throughout the United States, Europe, Japan, and Korea.<sup>42</sup>

## Computer-Aided Cost-Estimating System

In April 1982, Huntsville Division added the Computer-Aided Cost-Estimating System (CACES) to its list of missions. CACES was a computer system designed specifically to assist FOAs with military construction responsibilities to prepare final construction cost estimates. The system was originally developed to support cost estimating outside the continental United States, but after its effectiveness was realized, CACES was adapted for use in the United States. The Division became the agency responsible for the expansion, enhancement, and operation of CACES, ensuring that the system met all requirements for FOAs involved with military construction in the United States. Even before it was assigned the CACES mission, Huntsville Division had participated in the prototype testing of the system. During the test, the Division made suggestions that could improve the system, and those suggestions were ultimately incorporated.<sup>43</sup>

The Computer-Aided Cost-Estimating System provided standard formats in the following areas of cost estimating: in-depth cost analysis, rapid execution of changes and data manipulation, electronic transmission of estimates, historical means to monitor cost changes, time savings, management vehicle to control A-E support, and expedient and accurate cost estimating techniques. Although the system was designed for all FOAs involved in military construction, it was also recommended for Corps civil

works projects and for all other government agencies dealing in cost engineering. One of the biggest advantages offered by CACES was that estimates were easy to read because they were all in a similar format and they provided the user with a more detailed breakdown than the average estimator had time to perform.<sup>44</sup>

During FY 1982, five contracts, valued at about \$350,000, were awarded for various CACES-related work. All generic data bases were created during the year, and two districts were brought in line. A training class on the use of CACES was also conducted. By 1983, 15 to 20 Corps divisions and districts were on line and 46 others were expected to come into the system in the near future.<sup>46</sup>

When first developed, CACES appeared to be a promising system in engineering support; however, by the end of 1987, its potential had not been fully developed.

## **DD Form 1391 Processing System**

The DD Form 1391 was used by the Department of the Army to submit to Congress military construction requirements and justifications. The form was an important tool used in justifying the need for funds. In 1980, the Construction Engineering Research Laboratory developed a computerized system to assist users in preparing, submitting, reviewing, correcting, printing, and archiving the DD Form 1391 and related data. That same year, Huntsville Division was designated the Assigned Responsible Agency for system fielding, operation, maintenance, enhancement, and training for all Army customers worldwide.<sup>47</sup>

Early during its application, users of the system found that the processor was too expensive to use and not broad enough to take on certain capabilities. In attempting to remedy those complaints and provide a less expensive and more versatile processor, Huntsville Division undertook a study to identify weaknesses in the system and to recommend changes.<sup>48</sup> By the end of 1982, the system was corrected and the changes were implemented throughout the United States, including Alaska and Hawaii. The US

Army in Europe received training in the use of the system during September 1982 as well as a 90-day field test of the system. Plans were also underway to extend the system to the U.S. Army in Japan and Korea.<sup>49</sup>

On 1 July 1982, the system was converted from the National CSS, Incorporated, to the Tymshare, Incorporated, operating environment. The operational problems caused by the conversion required a substantial amount of the Division's time and resources to correct them. Work was also underway to begin redesigning the system in its entirety in FY 1983.<sup>50</sup>

During the remainder of the period, the DD Form 1391 Processor underwent extensive modifications and enhancement to support functional user requirements and to meet HQUSACE and Congressional needs. By the end of 1987, the system was accommodating the following military programs: Military Construction (Army), Munitions Production Base Support, Army Family Housing, Non-Appropriated Funds, Maintenance and Repair, Troop Support Agency, Army and Air Force Exchange Service, and Defense Medical Facilities Office. More than 26,000 forms were maintained, and about 500 forms were completed and placed in archives annually. There were some 800 user IDs that had access to the system through the PAX menu. The system was fielded worldwide by the Army.<sup>51</sup>

The 1391 Processor System was not without problems, however. The evolution of the system from a HQUSACE "checker" program to a total Army "Processor," the transformation of the DD Form 1391 from a 25- to an 11-block format, the several enhancements to support critically needed functional requirements, and the conversion of the Data Base Management System from RAMIS to FOCUS, resulted in what some called a "patchwork, convoluted system" that was sometimes inefficient and difficult to maintain. By 1988, Huntsville Division was in the midst of redesigning the system so as to modernize, improve efficiency, and increase system capacity to accommodate a growing number of users. The Idaho National Engineering Laboratories was contacted in order to aid the redesigning. The Division served as the central manager and technical monitor for the contract. The full deployment of the redesigned system was expected to be in operation by late 1989.<sup>52</sup>

## CE Guide Specifications and Technical Manual Program

One of the most important missions transferred to Huntsville Division from HQUSACE was the Guide Specifications and Technical Manual Program in July 1978. The mission involved the development and/or revision of the Guide Specifications Series Documents in order to promote uniformity in Army construction and provide requirements compatible with industry. By 1981, technical manuals could be used for design guidance and the delineation of technical criteria. In addition, several miscellaneous documents, such as emergency construction guide specifications and Army Reserve Center guide specifications, were being prepared. After those guides were prepared, each document was updated annually to improve its usability. Several other important related operations were also involved, including work on various standard drawings, preparation of design guide (DG Series) documents, and the Guide Specifications Notice Program.<sup>53</sup>

The inventory of guide specifications and technical manuals required constant attention in order to keep up with changes in technology; therefore, the Office of the Chief of Engineers created a formal program guaranteeing that the guides and manuals would be updated on a timely basis. Each document was reviewed at least once every three years, and no document bore a date older than five years. In FY 1982, 106 guide specifications, 21 technical manuals, and 2 design guides were reviewed in-house, by A-E firms, and by other Corps agencies.<sup>54</sup> The updating of guide specifications and technical manuals in FY 1982 included about 75 documents pertaining to military construction and 54 documents pertaining to Army Reserve Centers. Work on 36 documents was done in-house.<sup>55</sup>

The Guide Specifications and Technical Manual Program continued to play a major role in later years. At least 20 percent of the documents were revised and republished each year. In FY 1986, Huntsville Division sent 103 documents to HQUSACE for approval and publication. During the same year, there were 398 notices issued to guide specifications and technical manuals.<sup>56</sup> The following table reveals the number of documents, new or revised, that were handled in-house, by A-E firms, and by different Corps agencies, and their approximate funding for each year from FY 1982 to FY 1987:

**Table 9**  
**Guide, Specifications**  
**and Technical Manuals Handled<sup>57</sup>**

(\$ in millions/number of documents)

FY	A-E	In-house	Other Agencies	Total
1982	0.968/24	0.230/39	0.408/66	1.606/129
1983	1.050/23	0.230/28	0.700/20	1.980/71
1984	1.365/23	0.100/11	0.945/22	2.410/56
1985	0.850/18	0.110/20	1.093/31	2.053/69
1986	1.165/35	0.325/50	0.521/16	2.011/101
1987	1.072/24	0.517/36	1.002/34	2.591/94

## Economic Analysis System

The Economic Analysis System (ECONPACK) was developed jointly by the Pacific Ocean Division and the Construction Engineering Research Laboratory in 1984. The following year, Huntsville Division was designated the assigned responsible agency for the system. The system was available on Military Construction Programming, Administration, and the Execution (PAX) Computer System. The Economic Analysis System was an interactive computer program that assisted personnel in the preparation of life cycle cost analysis reports. Those reports directly supported funding requests for Army Family Housing, MCA, and other construction programs. Toll-free and local dial-in capability was provided for CONUS, Alaska Hawaii, Korea, Japan, Puerto Rico, Europe, and the Canal Zone.<sup>58</sup>

By the end of FY 1986, the system expanded its customer base and was routinely used by the Office of Management and Budget; Office of the Secretary of Defense; Headquarters, Department of the Army; and the Army Audit Agency. By the end of 1987, there were about 500 activities worldwide with access to the PAX System. In short, it was used by nearly all military agencies involved in some aspect of military construction.<sup>59</sup>

In 1986, the Construction Engineering Research Laboratory developed a companion version of ECONPACK for the personal computer. The new version was designed to be completely compatible with the PAX System, providing full-screen editing

and enabling the users to create and modify their data files without accessing the PAX computer. It also provided the capability to upload and download input files to and from the mainframe version. Huntsville Division was responsible for reproducing, documenting, maintaining, and improving the system for customers worldwide.<sup>60</sup>

When the system was first introduced there were the usual operational problems and "bugs" associated with software, but were soon corrected. Huntsville Division was able to identify a significant number of engineering improvements, and by the end of 1987, the Division was in the process of making the changes. A formal training course was also prepared for the system in 1987. The ECONPACK Program Management Plan was submitted to HQUSACE. Utilization of the system increased significantly in 1987 as additional customers received formal training and potential users became aware of the system's application.<sup>61</sup>

## Intrusion Detection Systems Program

Huntsville Division's experiences with the Intrusion Detection System (IDS) began long before the Division became the center of expertise in 1983. In 1981, the Defense Nuclear Agency asked Huntsville Division to select a site at Fort McClellan and design a facility that would evaluate state-of-the-art intrusion detection systems and security operations. Huntsville Division conducted a site evaluation and completed a conceptual study and design of the proposed facility. Construction of the new facility began in January 1983 and was completed that same year.<sup>62</sup>

In May 1982, facility engineers were given maintenance responsibility for the Army IDS. The following month, HQUSACE directed Huntsville Division to inform facility engineers of their technical capabilities in assisting districts with their IDS problems. In August 1982, the U.S. Army Mobility Equipment Research and Development Command briefed HQUSACE on the possible use of Huntsville Division as a Center of Competence in IDS, and in October 1982, following a directive from HQUSACE, Huntsville Division prepared a Management Concept Plan. The plan outlined the manner in which the Division proposed to improve and assist facility engineers in the program.<sup>63</sup>

It was not until December 1983 that Huntsville Division was designated a Center of Expertise for IDS, and it was not until December 1984 that its responsibilities were further clarified by designating it a Mandatory Center of Expertise and Design Center for the program. At the same time, the IDS Program Management Plan was made available to Huntsville Division.<sup>64</sup>

The Mandatory Center of Expertise became fully operational in April 1985. The center was to support USACE in criteria development for design, construction, procurement, testing, and evaluation of IDS. It was to provide FOAs and major commands with technical assistance during the design, construction, and check-out phases of the IDS. Upon request of the major commands, HQUSACE, and Corps divisions and districts, Huntsville Division was to conduct site surveys in order to determine which site was to be selected.<sup>65</sup>

After the program got off to a slow start because of inadequate funding and a temporary shortage of manpower, Huntsville Division pushed ahead more rapidly in FY 1986. The U.S. Army Western Command requested that the Division complete a perimeter IDS design for Johnston Atoll. In conjunction with that design, Huntsville Division also completed the request for proposal for a competitive negotiated construction contract for both IDS and a physical security design upgrade by the Navy. At AMC's request, Huntsville Division began designs for perimeter IDSs at six chemical weapons storage sites in the United States. The Division also supervised the Corps districts in their designs of 14 ammunition storage site security upgrades. In addition to those projects, Huntsville Division performed IDS site surveys at 12 CONUS installations. All the above-mentioned work was performed by the end of 1986.<sup>66</sup>

Adding to that Navy work load, in 1986, Huntsville Division signed a Memorandum of Agreement with the Product Manager for Physical Security. That agreement provided for engineering support in the deployment of facility intrusion detection systems at about 100 Army installations worldwide. The Chief of Engineers also directed Huntsville Division to conduct site surveys at 20 installations during FY 1987. The Division worked closely with the Technical Center of Expertise for protective Barriers at the Omaha District on four projects, including the development of requests for proposals for IDS and

physical security at Fort Benjamin Harrison, Indiana, for the 1987 Pan American Games, and the Chief Joseph Dam in Washington. The work load in the IDS program was so extensive that three additional technical manpower spaces were made available to the Division for the program.<sup>67</sup>

## Support to the Air Force Space Command

In 1984, the Air Force Space Command requested that Huntsville Division conduct a number of specialized engineering studies associated with the survivability of C<sup>3</sup> facilities. The Air Force Space Command also requested that the Division provide the design of some small Organization and Maintenance funded improvement projects. All those projects were related to the Power Reliability Enhancement Program and were the outgrowth of the Division's earlier involvement with that program. Colonel Poteat, who met with the Space Command Engineer in a visit to Colorado Springs, headquarters of the Air Force Space Command, envisioned a "large and important mission" for the Corps in supporting Space Command's high technology worldwide mission-related facilities projects. All those projects, he observed, should be intensely managed, requiring a high degree of standardization. He was convinced that Huntsville Division could well serve as Space Command's central Corps manager. He pointed to similar work performed at one time by the Division for the Ballistic Missile Defense Command. He believed that it was wise for the Army and the Corps to expand their ties with the Air Force Space Command as soon as possible.<sup>68</sup>

Lieutenant General Joseph K. Bratton, Chief of Engineers, agreed with Colonel Poteat that the Corps was an invaluable asset to the Space Command. He was convinced that Huntsville Division's involvement in the Power Reliability Enhancement Program and related experience in reliability and survivability analysis would be useful in assisting the Space Command in its worldwide mission.<sup>69</sup>

Colonel Abbott, who succeeded Colonel Poteat as Commander of Huntsville Division, agreed fully with his predecessor. His enthusiasm for a close relationship with the Air Force Space Command was made

more imperative because of a recent request by that command for Huntsville Division to station a liaison office in Colorado Springs, thus establishing a single point of contact for the Space Command. Although much of that command's needs were in the area of the Power Reliability Enhancement Program, the command also had in mind that the Corps would support future programs required for integrated operations under a unified Space Command. Colonel Abbott saw this as "an opportunity for the Corps of Engineers to provide central management of the future construction for the unified Space Command."<sup>70</sup>

In a follow-up letter to the Chief of Engineers, Colonel Abbott expressed his enthusiasm for future relations with space initiatives in the following words:

In my view, the high level of interest and activity in space prompts the need for USACE to have a strong, visible POC for space initiatives. USACE has a proud history of leading the way into new frontiers and space should not be an exception. There is a need for leadership in the area now.... In conjunction with their space platform program, NASA is setting conditions (e.g., dimensions, functions, fabrication methods, and materials) that will become the standards for that industry. As a minimum, in my view, USACE should be maintaining close liaison with NASA to learn from and, to the extent possible, influence those engineering-related aspects of the program that may have future application for DOD. Finally, during my 13 August visit to the Space Command... Colonel Knutsen stated an interest in establishing regular dialogue with USACE on space-related requirements. He is especially interested in assuring that there is a coordinated effort to provide land and space based facilities to support the requirements of his current organization and the soon to be formed Unified Space Command.<sup>71</sup>

Even before Colonel Abbott wrote those words of confidence, a Memorandum of Agreement delineating Huntsville Division's Space Command responsibilities was signed on 12 August 1985 between Huntsville Division and the Air Force Space Command. That same month a full-time Division liaison representative was assigned to Colorado Springs.

While it seemed as though the earlier enthusiasm over Space Command was to mushroom into a sup-

port of some considerable proportions, events proved otherwise. In January 1987, following a disappointment in the lack of support requested by the Space Command, Huntsville Division withdrew its liaison position. Ironically, in July 1987, Huntsville Division notified the Space Command that it was unable to provide the support called for in the Memorandum of Agreement because of a lack of resources. Although the Division had done work for the Space Command in previous years, the work was now beyond the capabilities of its resources. According to Colonel William A. Miller, Deputy Commander of Huntsville Division, this admission was a "very painful process." Huntsville Division had to find another organization -- the Department of Energy's Idaho National Engineering Laboratories -- to accomplish the work. Meanwhile, the Division's technical review and support to the Space Command, with the exception of the Generator Replacement Project at the Cape Cod Air Force Station, was terminated on 30 September 1987, and even the work at Cape Cod was expected to end by 15 June 1988. In retrospect, Colonel Miller sadly noted that "We may have learned a lesson, not to be over-committed."<sup>72</sup>

## Facilities

### Standardization Program

From the time it was first implemented by the Army's Vice Chief of Staff, the Facilities Standardization Program had expanded to become widely accepted throughout the Army. As a vital participant in that important program, Huntsville Division was assigned design responsibility for 16 different types of facilities ranging from outdoor sports fields to storage igloos. The work involved criteria development support to the Department of the Army staff proponent and subcommittee, definitive design of the facility, and continued monitoring, maintaining, and revising of the standards. In addition, Huntsville Division was appointed central repository and distributor of all Army standard designs.

As part of that broad standardization program, Huntsville Division was directed in 1981 to develop standard facility designs that would support additional troops and equipment moved onto Army installations in the continental United States under total mobilization. Preparations in national defense were usually seen in terms of weapons systems and man-

power, but to Huntsville Division preparedness also meant being ready to provide architectural drawings. The Division concerned itself with questions such as "if an Army installation was needed somewhere in the United States, how long would it take us to respond?" or "would appropriate standard designs and materials be available in any given location?" In order to answer those questions positively, Huntsville Division knew that designs needed to be standardized. Huntsville Division was directed to develop a set of standard, low-cost, rapid construction facility designs for use at CONUS installations. The tasking also included the development of guide specifications and engineering manuals to apply to the standard designs.

Initially, two contracts were awarded in FY 1982 for mobilization standard drawings. One contract, awarded to E.I. Brown Company in September 1981 for \$4.9 million, was for the design of high-priority facilities. The second contract, awarded to CRS Sirrine Company in September 1982 for \$3.8 million, was for the preparation of guide specifications and engineering manuals.

On 25 September 1982, a third contract was awarded for the design of 45 additional facility types. The first group of final standard designs was received for government review in November 1982. All designs, guide specifications and engineering manuals were completed by mid-1983.<sup>73</sup>

A Phase III design contract was awarded to Samborn, Steketee, Otis and Evans in January 1984 for \$1.5 million. By 1987, the designs, bills of materials, and cost estimates were completed. The in-house designs of an expedited hutment and two operating room surgery units were also completed, including bills of materials and cost estimates.<sup>74</sup>

The contractor accomplished the work through the use of a computer to develop drawings, calculations, and cost estimates so that the designer could quickly assemble the drawings for any type of facility from a barracks to a battalion headquarters. The Huntsville Division computer graphics system stored the final designs and made them available to all Corps districts. The districts were responsible for modifying the standard designs to the actual site. The goal of the program was to have up-to-date realistic building plans ready in the event of mobilization or national emergency.<sup>75</sup>

The initial phase of mobilization designs was to produce 35 different facilities, but that number was

later extended to 50, and included facilities such as billets, dining facilities, administration buildings, and others. The second phase was to develop final standard designs for an additional 59 temporary structures. The third phase was to develop standard designs for 39 more temporary facilities. Two facilities were designed in-house. The fourth phase was to develop total mobilization standard designs for production and support facilities for AMC. Ultimately, standard designs were to be developed for all facilities required for total mobilization in the continental United States. By the end of 1987, the first three phases of the program were complete, but the tasking and scheduling for the fourth phase remained undetermined.<sup>76</sup>

Under the Facilities Standardization Program, Huntsville Division finalized designs for Child Development Centers, a project initiated by HQUSACE in January 1986 and for which the Division was designated a center of expertise. The Child Development Center Program consisted of six facility sizes. Two were ready for site adaptation, and four were 60 percent complete by the end of 1986. Because of the innovative manner in which they were designed and packaged, the Child Development Centers created the standards for all future definitive designs done Armywide.<sup>78</sup>

In 1987, standard design work involved fire stations, physical fitness centers, and outdoor sports fields. In addition to those facilities, new standard designs were made in-house for cubicle magazines, earth-covered steel arch magazines, blast and fragment barricades, and classified material storage vaults.<sup>79</sup>

## Terrain Analysis

Since the assignment of the Terrain Analysis mission in 1977, Huntsville Division awarded contracts to A-E firms that would perform the analyses in selected areas around the world. The object of the mission was to support the Corps' Engineer Topographic Laboratory in providing base commanders with mission planning documents. The analyses presented essential information for evaluating the effects of terrain and man-made facilities upon Army field operations both from an offensive and defensive standpoint. The scope of the program included cartographic engineering services for the preparation of stable base film overlays for the fol-

lowing terrain and related features: surface configuration, vegetation cover, concealment from aerial detection in Summer and Winter, surface drainage, transmission lines and facilities in built-up areas, LOC-Highways, railroads and airfields, cross-country troop movement, key terrain, climate, transportation, surface materials (soils), obstacles, groundwater, and existing water. By October 1982, 16 projects were awarded under firm-fixed A-E contracts, and 15 were completed, with one contract modified to add more areas to the analysis. By 1987, the number of contracts awarded to A-E firms increased to 34.<sup>80</sup>

Firms selected to perform these analyses had to possess (or at least were potentially able to gain) a top secret security clearance with a sensitive Compartmented Information Facility and appropriate personnel clearances. Very often that top secret security clearance presented a problem, since it limited the number of contractors that could participate in the program. Huntsville Division attempted to enlarge the pool of A-E firms available to conduct this work, but by the end of 1987, only two firms could meet the qualifications. To make matters worse, both firms were unavailable because of other commitments. Finally, there was the problem of extensive processing time that was needed to obtain security clearances, which inevitably delayed the start of projects for as much as one to two years. Faced with those circumstances, Huntsville Division was uncertain how work in this program, which consisted of six projects in FY 1988, would be carried out.<sup>81</sup>

## EMP/TEMPEST

A highly technical area in which Huntsville Division played a role since 1984 when it was first designated a Mandatory Center of Expertise was the Electromagnetic Pulse/Electromagnetic Emanations and TEMPEST mission. Huntsville Division provided highly technical support to seven customers in the continental United States and in two locations outside the United States.<sup>82</sup>

Protection of sensitive equipment against electromagnetic pulses emanating from a high-altitude nuclear detonation was of serious concern to many government agencies. Also of some concern was the accidental emanations of coded communications. Both areas were similarly treated, and TEMPEST was a program designed to prevent those

emanations. Through its Advanced Technology Section, Huntsville Division was to provide protection of sensitive equipment in the event of serious interference. Huntsville Division was to provide criteria development, design, construction surveillance, validation testing, hardness maintenance, research and development, standardization, and facility surveys. Between FY 1984 and FY 1988 \$1.65 million was funded for the program for various projects.<sup>83</sup>

By FY 1988, Huntsville Division was working on four projects, three of which were in the United States and one in South Korea. Construction of one project at Fort Meade, Maryland, was completed. Two others, one in Seoul, South Korea, and another at the Waterways Experiment Station's Automated Technology Facility, were under construction, and for a fourth, "Site R" in the United States, a construction contract was awarded in July 1987.<sup>84</sup>

## FORSCOM

### Railroad Improvement Program

The purpose of the Railroad Improvement Program was to ensure rail transportation readiness on Army installations in time of national emergency. In August 1981, HQUSACE designated Huntsville Division as the center of expertise for the Army's Forces Command (FORSCOM). Huntsville Division would assist in improving railroad facilities on Army installations in support of the Rapid Deployment Force and Mobilization missions. Prior to that assignment, Huntsville Division had successfully managed several railroad projects as part of the Munitions Base Production Program and was able to manage other activities that transcended district boundaries. The Division also had proven expertise available in other Corps divisions and districts. Huntsville Division was therefore the logical organization to undertake such a program.<sup>85</sup>

Initially, FORSCOM identified 31 installations that required railroad repairs, 19 of which were in the Training and Doctrine Command (TRADOC), AMC, and Air Force. The actual design and construction was to be done by the districts, with central management provided by Huntsville Division. Huntsville Division was given a budget of \$22 million to perform the repairs and purchase hand tools and sets, spanners plates, and portable end-loading ramps

for all 31 installations during FYs 1982 through 1984. The first phase was to include eight installations in five different Corps districts -- Savannah, Kansas City, Omaha, Seattle, and Fort Worth. However, in January 1982, the program was reduced to 23 installations -- 11 FORSCOM and 12 TRADOC installations. Designs were begun on two installations and about to begin on five others. The installations involved at that point were Fort Bragg, Fort Riley, Fort Stewart, Fort Lewis, Fort Carson, Fort Bliss, and Fort Hood. For the railroad repair program on those installations, Huntsville Division received \$8.9 million from FORSCOM.<sup>86</sup>

In January 1982 Huntsville Division awarded a service contract that would conduct ultrasonic testing of rails at six installations. Limited funds held the testing to that number, but as funds became available, two more installations were added to the contract. By mid-1982, a total of 14 installations were added to the list. The results of the ultrasonic tests revealed defective rail sections for 97.4 miles of track.<sup>87</sup>

The FY 1982 program was reduced to the repair of rails at only one installation -- Fort Riley. The Department of the Army did not agree to replace the large number of rails that were considered by Huntsville Division to be defective. Moreover, the repair of rails at Fort Riley was limited to only the most defective rails and some lighting facilities. In September 1982, the Kansas City District awarded the only rail repair contract (Fort Riley) in the FY 1982 program at a cost of \$691,000. The completed designs for Fort Bragg, Fort Stewart, and Fort Bliss were shelved.<sup>88</sup>

In FY 1984, the Railroad Improvement Program expanded with the release of funds Huntsville Division developed 24 criteria documents, monitored 17 designs undertaken by the districts, and awarded 12 construction contracts. By the end of 1985, a total of 23 installations were repaired with more scheduled for repairs in FYs 1986 through 1991. As part of its responsibilities, Huntsville Division's Procurement Division purchased blocking, bracing, packing, crating, and tie-down (BBPCT) equipment and other maintenance items for FORSCOM that were related to railroad repair.<sup>89</sup>

While the testing, design, and construction of rails was now moving along at a more reasonable pace, training became a new facet in Huntsville Division's involvement in this program. The Training Division scheduled three training courses in 1985. One course

trained engineers at Corps divisions and districts about the design of railroad repairs. A second course trained installation personnel about railroad track maintenance. A third course trained troops (expected to become a part of any anticipated mobilization) in the use of BBPGT material.<sup>90</sup>

## Energy Programs

During the period of the history, Huntsville Division became involved in several energy programs designed to increase fuel reserves, introduce new types of energy (such as solid and fossil fuels) into the supply system, and analyze and monitor energy consumption at installations. For several of those programs, the Department of Energy (DOE) was the customer, but the Army's major commands were also major customers. The Division was given a role in the Strategic Petroleum Reserve Program and in the High Btu Pipeline Coal Gasification Program. The Strategic Petroleum Reserve Program was designed to minimize the effects of the oil supply reduction, and the High Btu Pipeline Coal Gasification Program was concerned with processes for the conversion of coal to an environmentally sound substitute for natural gas. Those two programs were soon terminated when the fuel emergency of the seventies was no longer a serious factor and after the price of oil declined.<sup>91</sup>

Despite the termination of the Petroleum Reserve and Coal Gasification Programs, Huntsville Division was left with a variety of energy programs in support of the Army, thus providing the Division with work in areas of high technology. In at least three of the energy programs, Huntsville Division was designated a center of expertise. Those three programs are summarized below.

**Energy Monitoring and Control Systems (EMCS).** In 1979, Huntsville Division was designated the center of competence for EMCS.<sup>92</sup> The purpose of EMCS was to establish, through a computer based system, a means of saving energy at Army installations. Under that program mechanical and electrical systems, such as heating, ventilating, air conditioning, and lighting, were controlled and monitored from a central location, thereby enhancing equipment operation and save energy (Fig. 27). In addition to providing a series of design and construction support,

Huntsville Division was to prepare a technical manual for design, guide specifications, and a course of instruction to be offered in its regular Training Division program. In early 1982, Huntsville Division completed the technical manual, specifications guide, and a design course of instruction. The first two documents were approved and printed, and the courses of instruction were initiated with additional courses scheduled for the future. The guide specifications were adopted as Tri-Service Documents. Five design courses were taught in FY 1982 and FY 1983, and five more were given in FY 1984. By 1986, Huntsville Division was conducting four 40-hour courses each year for the Army, Navy, and Air Force. Separate courses were held for A-E firms and other agencies that designed EMCS for the government or intended to do so in the future.<sup>93</sup>

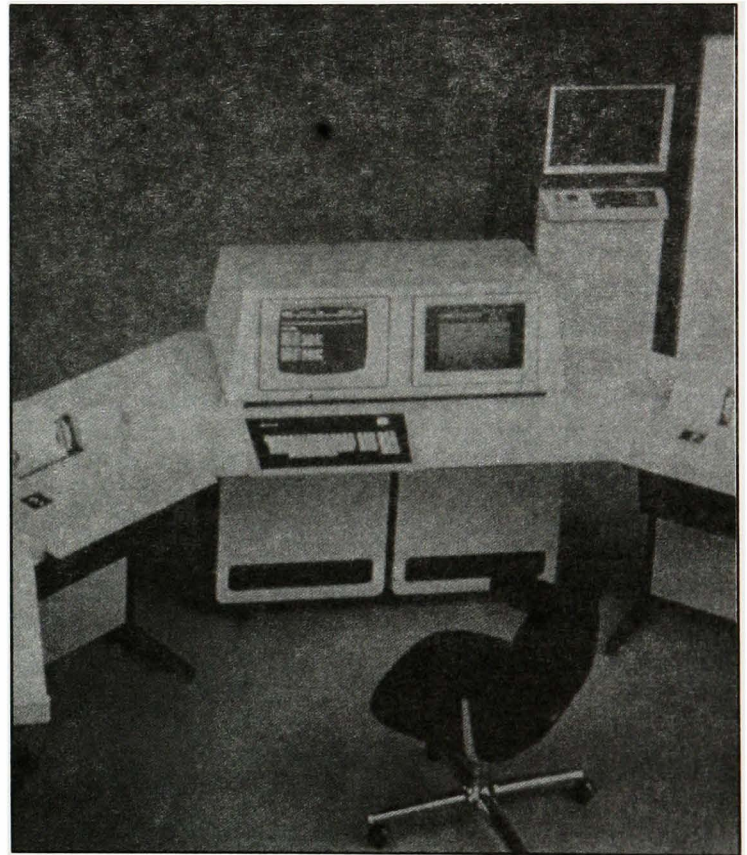

Fig. 21. EMCS Computerized Station

The biggest effort by far undertaken by Huntsville Division in the EMCS program was the development of the Tri-Service Specifications for equipment and structures. The specifications were devised in 1977 by DOD in order to establish standards for energy management systems at military bases. The specifications were also employed by a number of federal agencies and the private sector, and particularly by universities and school districts. An early draft of the

specifications was reviewed in 1984 by a joint military committee, which recommended 21 revisions to the guide, including a conversion from a prescriptive-based to a performance-based requirement, the introduction of more stringent testing procedures, and an upgrading of the system's equipment from commercial to industrial quality. Both the system's manufacturers and military officials agreed that the guidelines were antiquated and had failed to keep pace with technological advances in industry. After the proposed revisions were reviewed by EMCS manufacturers and contractors at an industry forum, the revisions were incorporated in the guidelines. Mr. Frank Carlen, an engineer in Huntsville Division, who was involved with EMCS from the beginning, observed, "What we have tried to do is make the specifications as much performance-oriented as we could and give suppliers ability to do things in a different way."<sup>94</sup>

Although the manufacturers accepted many of the revisions to the specifications, they balked at the military's plan to tighten the testing procedures. They insisted that the proposed testing was too strict and would limit the manufacturer's ability to bid on military contracts. Faced with this opposition from the manufacturers, the joint military committee agreed to develop a modified version of the proposed testing procedures.<sup>95</sup>

Other forums were later held in order to review and possibly revise the guide specifications: one by the joint committee in 1986 and another by industry in 1987. An industry forum was also held in Europe in 1987 for the same purpose. The guide specifications were finally revised and published in February 1988.<sup>96</sup>

Following these forums, leading to the revision of specifications, Huntsville Division participated in several reviews of EMCS design packages as well as in factory and field tests for divisions and districts. A trainer-simulator was also developed in conjunction with the Naval Civil Engineering Laboratory and the National Bureau of Standards for use in site testing.<sup>97</sup>

While it was true that EMCS was proving to be a most effective tool in conserving energy, there were two problems that hampered its use. The first was the high turnover of technical coordinators within Corps divisions and districts, resulting in untrained personnel executing the program. The second problem was the failure of some divisions and districts to follow the Program Management Plan. Nevertheless, despite

those problems, Huntsville Division's efforts in EMCS, as in other energy programs, remained largely successful.<sup>98</sup>

**Energy Engineering Analysis Program (EEAP).** The EEAP was created in July 1977 for the purpose of reducing energy consumption at Army installations. Goals established at the time were a 20 percent reduction in fuel consumption for existing facilities and a 45 percent fuel reduction for new facilities by 1985. The overall long-term goal was a 50 percent reduction by the year 2000. In September 1979, the central management of EEAP was assigned to Huntsville Division as a center of expertise. Corps districts were to conduct installation energy consumption surveys and devise methods for reducing consumption. Huntsville Division was to provide central management and technical assistance to accomplish those goals.<sup>99</sup>

The analyses of energy consumption and the needs of the installation and the development of projects for energy conservation showed that all reasonable, practical, and economic methods were considered. For each installation analyzed, a plan was prepared for the implementation of projects. Each plan projected the percent of energy that would be saved in 1985 in relation to the 1975 baseline. For each installation analyzed, an energy management plan was developed for the facilities engineer, providing him or her with suggestions for the day-to-day operations of existing energy-consuming systems and descriptions for modifications that could be made in-house at little or no cost.<sup>100</sup>

From the time of the program's inception until FY 1984, Huntsville Division managed \$60.7 million in EEAP activities. The work involved base-wide studies of 122 installations in the United States, 88 outside the United States, and detailed surveys of 25 posts within the United States. Huntsville Division was commended by its EEAP customers. Furthermore, the Division and two of its employees received awards from the Army's Deputy Chief of Staff for Logistics in October 1984 for their work in the program. The award was for "Outstanding Contribution to the Army Energy Program."<sup>101</sup>

In FYs 1983 and 1984, Huntsville Division prepared new general scopes of work that concentrated on specific energy conservation measures. Since the base-wide surveys were nearing completion, the new scopes were intended to expand the program to include surveys of the following military

facilities: hospitals, boiler and chiller plants, dining facilities, laundry facilities, industrial facilities, commissaries and post exchanges in CONUS, and Savings Opportunity Surveys. All but the Savings Opportunity Surveys were to concentrate on individual buildings. Under the expanded program, hospitals were the first to be surveyed, and six contracts were awarded for that purpose in FY 1983. Meanwhile, the Energy Savings Opportunity Surveys demanded significant efforts on the part of installations in the following areas:

- Re-evaluation of project or energy conservation measures of the base-wide studies that had, as yet, not been programmed or implemented.
- Surveys of selected buildings or areas that had not been included in the base-wide study.
- Surveys and analyses of specific energy conservation measures for specific buildings or facilities.<sup>102</sup>

The program was so successful in six years of operation that it was able to surpass its 1985 goals by reducing energy consumption by 21.8 percent. Then in December 1985, the Assistant Secretary of Defense set new goals for 1995: to reduce consumption by another 8 percent.<sup>103</sup>

By the end of 1987, the base-wide surveys were all complete and the only work that remained were a few detailed studies. Work continued on specific energy conservation measures for energy-intensive facilities. Huntsville Division continued to prepare and update scopes of work for those facilities during FYs 1984 through 1988.

Army Reserve Centers in Houston, San Antonio, and Austin were included in FY 1988 test cases. Thirteen surveys were scheduled for FY 1988 -- 11 in CONUS and 2 in OCONUS.<sup>104</sup>

**Solid Fuel Conversion Program.** In, 1981, HQUSACE designated Huntsville Division a center of expertise in the Solid Fuel Conversion Program (SFCP). The Division was responsible for developing a core of engineering expertise in the design of central coal-fired boilers (and other solid fuels) for selected generation plants.

The objectives were to maintain a continuous familiarity with advanced technology and current regulations governing air quality, energy conservation, and alternate fuels; improve cost estimates; achieve commonality in programming documentation for similar requirements, using the latest technology; and standardize designs for functional systems.<sup>105</sup>

By April 1986, 16 installations were being considered for adaptation to central solid fuel boiler plants by the end of FY 1995.

Three were in advanced stages of design -- Red River Army Depot, Redstone Arsenal, and Fort Bragg -- with several others in the early programming stages. After evaluating the cogeneration economic analysis for Redstone Arsenal, Huntsville Division opposed cogeneration at the arsenal. Headquarters, United States Army Corps of Engineers proposed the design of a low-pressure start without cogeneration. Headquarters also insisted that each project be reexamined to determine if overall costs could be reduced or if construction could be stretched out over a number of years.<sup>106</sup>

As early as 1982, the program was running into funding difficulties. By the end of 1986, because capital costs for new boiler plants were high and because Congress was considering third party contracting as a means of funding projects, all SFCP projects were placed on hold pending further study by Congress.<sup>107</sup>

# Major Procurement Missions

In its Contracting Division (formerly known as Procurement Division), Huntsville Division had the only procurement and contracting element in the Corps of Engineers with program and project management responsibilities. Therefore, the Contracting Division provided services to the Division and its customers. It provided contractual support to Huntsville Division's design and management elements, an activity normally expected of a procurement staff section, and it was directly involved in logistics planning, design, and central management of certain specialized major procurement and contracting programs supporting Huntsville Division customers.

Before 1982, Huntsville Division had undertaken several procurement missions that supported customers. Some of these missions involved support of the SAFEGUARD Ballistic Defense System Construction Program, procurement of government-furnished equipment (GFE) for the U.S. Postal Service Bulk Mechanization Program, government-furnished property (GFP) procurement services in support of the Saudi Arabia Construction Program, and the procurement of industrial plant equipment and tools for the Jordanian Armor Rebuild Facility Construction Project in Amman, Jordan.

All these missions required the procurement of large quantities of government-furnished property over extended periods of time in order to support U.S. Army customers inside and outside the United States. For those GFP missions, the Contracting Division was the lead staff section in planning, designing, and managing the procurement system for long lead and standardized items.

Because Huntsville Division had gained such varied and extensive experience in the procurement of GFP, it was inevitable that Division would be called upon often to exercise its expertise in the GFE area during the period 1982-1987.

## Government Furnished Equipment (GFE) for the U.S. Army in Europe

In FY 1983, the Corp of Engineers' Europe Division requested that Huntsville Division provide GFE for its ongoing Weapons Access Delay System (WADS) Program. Items to be procured included complex nonpyrotechnic smoke generators, fire sets, and command and control units. By October 1983, Huntsville Division received \$3.5 million to purchase 326 units. In 1985, 443 units were purchased through competitive negotiations for a total of \$2.7 million.<sup>1</sup>

Subsequently, Huntsville Division and the Europe Division signed a Memorandum of Understanding in which Huntsville would provide acquisition support to Europe's local requirements and major construction projects. One such procurement project was a desalinization plant for Sinop, Turkey, where Huntsville Division acquired three vapor compression evaporator units for about \$1 million.<sup>2</sup>

## Support to the Office of the Surgeon General

One of the largest GFP programs undertaken by the Contracting Division was support to the Office of the Surgeon General (OTSG). That program evolved from supporting the previous GFP programs such as the Saudi and Jordanian programs. Support to the OTSG consisted of two parts. One was procurement of furniture and furnishings for new Army medical facilities. The other dealt with engineered procurement, such as surgical and medical equipment. The furniture and furnishings were usually funded with OPA funds; the equipment was funded through Military Construction, Army funds (Fig. 22).<sup>3</sup>

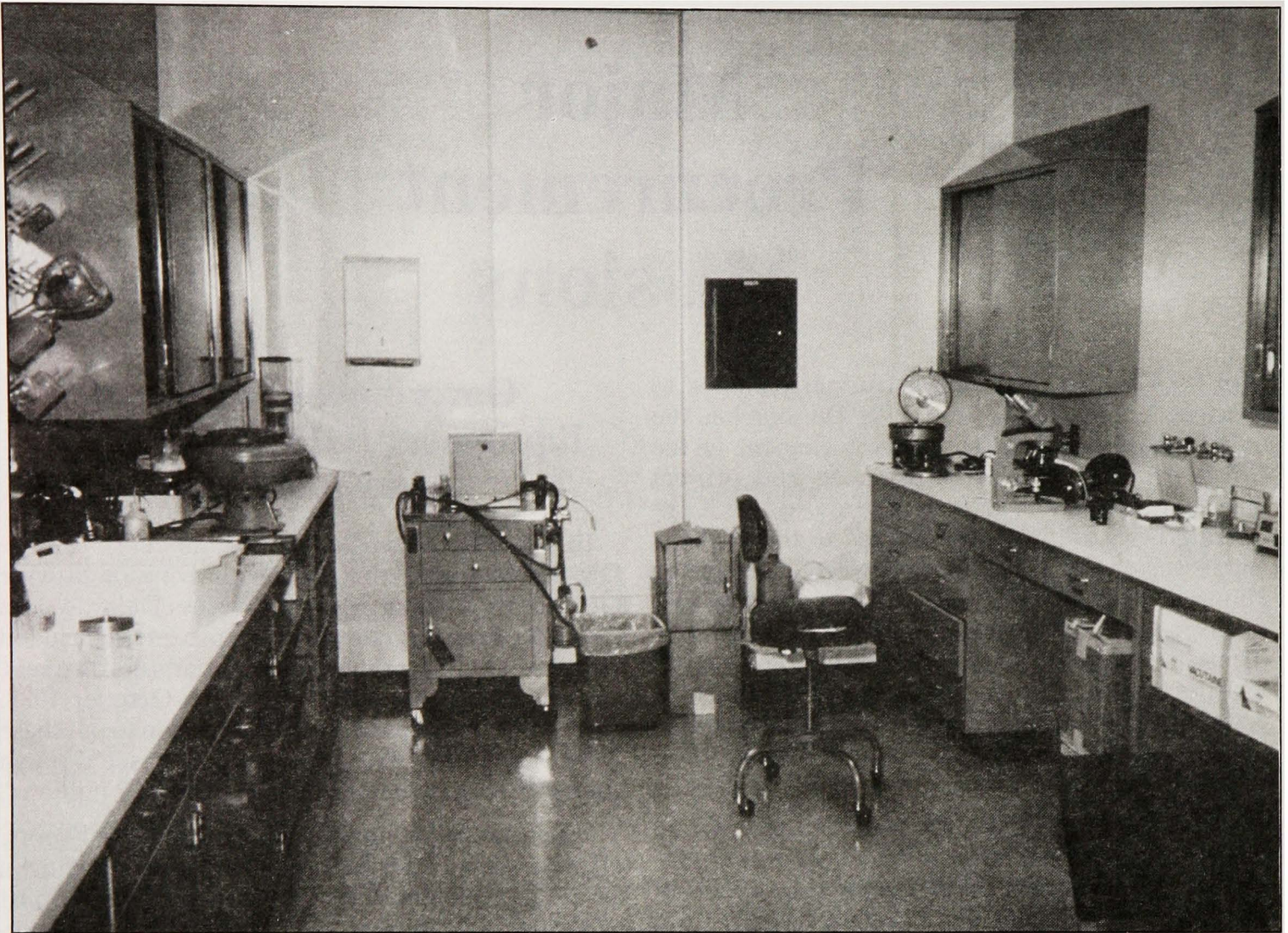

Fig. 22. Section of a Furnished Medical Facility

The program started because OTSG had difficulty procuring items through normal channels due to the complexities of such a major undertaking. The Surgeon General needed a standardized design for new facilities, an effort that demanded considerable time and effort to plan, design, procure, and manage contracts. Huntsville Division with its highly technical engineering and procurement resources, was the logical organization to undertake the mission.<sup>4</sup>

The Office of the Surgeon General contacted Huntsville Division to employ the Contracting Division as the central procurement activity that would purchase furniture and furnishings for its new construction of Army Health Care Facilities worldwide and provide services for interior design.

A proposed Memorandum of Understanding was finalized by both parties one year later. While the Memorandum of Understanding was pending,

Huntsville Division provided procurement services for the OTSG on a task-by-task basis for various medical facilities in Europe, the Far East, and the United States.<sup>5</sup>

In February 1982, the U.S. Army Medical Material Command (USAMMA) at Fort Detrick, Maryland, requested procurement assistance from Huntsville Division, pending ratification of the Memorandum of Understanding with OTSG. The Division agreed to assist on a project-by-project basis, and in March 1982, received a \$100,000 package to procure furniture and furnishings for a dental clinic in Heidelberg, West Germany.<sup>6</sup>

At the same time that USAMMA made its request for assistance, OTSG asked Huntsville Division to revise furniture and furnishings specifications for the Army hospital at Fort Stewart, Georgia. The Contracting Division revised the contractor - developed

specifications into a generic form so that OTSG could acquire the required items using competitive bidding procedures to the maximum extent possible. Subsequently, the Contracting Division acquisitioned, received, stored, and installed, under contract, the furniture and furnishings. The total acquisition cost of the Fort Stewart project was about \$1.5 million. The hospital was the first major facility furnished under the OTSG furniture and furnishings program, and was to serve as a model for future work.<sup>7</sup>

During the following two years, the Contracting Division acquisitioned items for 17 medical and dental facilities in West Germany, 2 facilities in South Korea, and 7 facilities in the continental United States. A total of 2,321 line items were purchased for the facilities at a total value of more than \$4 million.<sup>8</sup>

Between April and August 1984, the Contracting Division purchased items for Fort Campbell, Fort Ord, Fort Benning, and Fort Rucker, in addition to furnishing an assortment of medical items for USAMMA's facilities outside the United States. Huntsville Division also developed the interior design package for the Fort Rucker Army Hospital.<sup>9</sup>

At first, the procurement of OTSG furniture and furnishings was estimated at about \$5 million for each FY 1982 and FY 1983; however, through 1987, the actual amount rose to \$9 million. It appeared that the program had an indefinite time frame.<sup>10</sup>

In March 1984, a Memorandum of Understanding between Huntsville Division and OTSG expanded the procurement support to be provided to include engineering equipment. Under that agreement, Huntsville Division was to provide engineered equipment specifications and procurement support for the acquisition of items such as sterilizers, surgical lights, dental lights, X-ray film processors, washers, dryers, blood bank refrigerators, and acoustical rooms. Like the furniture and furnishings program, government-furnished medical equipment was intended for the renovation and construction of new Army Health Care Facilities worldwide. By the end of 1984, about 100 different types of items of equipment, totalling more than \$2 million, were procured and delivered to hospitals in Bremerhaven (West Germany), Fort Carson (Colorado), Fort Ord (California), and to the 97th General Hospital in Frankfurt (West Germany). Engineer equipment specifications were finalized for those items so as to ensure maximum competition in the acquisition of future medical equipment. The specifications also ensured that the correct equip-

ment would be purchased with all the essential components and characteristics needed to interface with the facility as designed and constructed, thereby eliminating future costly construction change orders.<sup>11</sup>

## Government Furnished Property Support to Other Agencies

By 1987, the procurement support to the OTSG proved to be such a success that other federal agencies (both in and out of the Army) were requesting similar support from Huntsville Division. After three years of working for the OTSG, the Army directed Huntsville Division to procure furniture and furnishings for Army Reserve Centers throughout the United States. Huntsville Division assisted in the design of the items and the maintenance and distribution of the design guides, procured them in the competitive market, and scheduled and managed deliveries. At the same time, the Division supported the Army Environmental Health Agency by awarding contracts for equipment that tested noise pollution. The Division also supported the Defense Nuclear Agency in acquiring access delay systems. Huntsville Division first provided access delay systems in Europe and later in the United States. These 1987 procurement missions were so successful that as 1988 was approaching, the U.S. Air Force was believed to be preparing to request similar support for some of its own projects.<sup>12</sup>

## Third Party Contracting

In 1982, Congress passed Public Law 97-214 giving military agencies the authority to enter into long-term third party contracts that would provide, maintain, and operate utilities at military installations. The concept evolved from attempts to encourage private enterprise to develop utility plants at military installations, using alternative energy sources such as geothermal, biomass, solar, and other energy systems. Under the law, military establishments were permitted to enter into agreements of up to 30 years with a third party, who would then build and operate a plant to furnish fuel, steam, or power to a military installation. The Senate Armed Services Committee urged the military branches to pursue the third party contracting option aggressively wherever economics

appeared favorable. The term "third party" was derived from the three primary partners concerned in the contract: the federal government (customer-user), the builder and operator of the plant, and the financier.<sup>13</sup>

On 11 July 1983, Huntsville Division was designated the Department of the Army's Center of Expertise for third party energy contracting. The Division was made responsible for preparing a sample request for proposal, conducting technical reviews and economic analyses of proposals, and performing related work.<sup>14</sup> The program applied to all military construction involving energy plants with a thermal energy input of 100 MBTU per hour. Third party contracting for utilities remained optional for smaller plants.<sup>15</sup>

Huntsville Division immediately grasped the opportunity to make the new mission a success. Seven months after the mission was assigned to the Division, Colonel Poteat, the Division Commander, enthusiastically described to the Chief of Engineers the steps that his organization had taken to fulfill the mission. The Division had prepared a mission management plan and distributed it as a guide to interested parties. Huntsville Division had identified a wide array of policy issues that needed to be addressed. The Division had surveyed the major commands and installations, thereby ranking needs and work load. It had selected an A-E firm to provide technical and economic evaluation support. Finally, the Division had prepared a generic draft of a request for proposal that could be used to solicit proposals from the private sector. Ten different installation proposals were initially referred to the Division.<sup>16</sup> Lieutenant General Joseph K. Bratton, Chief of Engineers, was pleased with the way in which Huntsville Division had assumed its new mission, particularly since the work was done in such an "abbreviated timeframe."<sup>17</sup>

Once the potential projects were identified and ranked, Huntsville Division developed requests for proposals and advertised them through commercial markets. The Division then evaluated the proposals that were received and recommended to the Department of the Army an appropriate contract for implementation by the private sector for the design, construction, operation, and maintenance of one of these plants. By mid-1984, Huntsville Division received funding in the amount of \$350,000, while an additional \$1.2 million was anticipated for FY 1985.<sup>18</sup>

The mission was underway when Colonel Abbott assumed command of Huntsville Division. It was disrupted only once, a delay of four months, because of a legal issue arising from a contract provision to terminate third party contracts for the convenience of the government. Legal issues being resolved, a small biomass heating plant at Fort Leonard Wood became the pilot project for the third party mission. In the meantime, the heating plant at Fort Drum, New York, became the first major undertaking under third party contracting. The project was on schedule, and the U.S. Army Forces Command was pleased with the request for proposal prepared by Huntsville Division. That command received feedback from industry that the proposal was exceptional.<sup>19</sup>

The Army's first third party contract was awarded to Jones Black River Services, Inc. on 10 November 1986. The contractor was to provide Fort Drum with high temperature water energy for 25 years.<sup>20</sup>

The passage of Public Law 99-167, "Military Construction Authorization Act," in 1986 expanded third party contracting to include non-energy-related test cases for child care services, wastewater treatment plants, and depot supply activities. Legislation passed that same year added to the list other categories of construction, such as potable water, troop housing, transient quarters, and logistics and administrative services other than depot maintenance. In August 1987, Huntsville Division was designated the assigned responsible agent (ARA) for conducting studies and contract negotiations as they related to third party contracting for military wastewater treatment plants and potable water processing plants. Assigning those types of projects to Huntsville consolidated all similar responsibilities for third party contracting meterable services, an action that was consistent with the Division's responsibilities for third party contracting energy projects.<sup>21</sup>

Huntsville Division later asked for and received authority from HQUSACE to spread the responsibility for initiating third party contracts for non-energy type projects among some of the Corps districts. As a result, four projects were assigned to an equal number of Corps districts for execution.<sup>22</sup>

During the period of the history, Huntsville Division was involved in four energy-related third party contracts: Fort Drum, New Cumberland Army Depot, Picatinny Arsenal, and Detroit Arsenal. Fort Drum was the only project where Division efforts were finalized. The others remained in various stages

of preparation. A total of \$687,000 was used for Huntsville Division's work on energy projects for FY 1987, and an additional \$200,000 was budgeted for FY 1988. In the area of non-energy-related third party contracts, an assignment still relatively new, Huntsville Division was tasked to perform a study for Redstone Arsenal, Alabama, wastewater treatment. Funds amounting to \$250,000 were received for that project, and a draft of the request for proposal was disseminated for review. Solicitation for the contract was scheduled for June 1988.<sup>23</sup>

## Shared Savings Contracting

Shared Savings Contracting, enacted by Congress through the passage of Public Law 99-272 on 17 April 1986, was another cost-savings initiative whereby, for example, the cost of building and operating a utility on an Army installation came from the savings in energy costs by the individual company. The savings are those shared by the company and the federal government -- hence, the terminology "Shared Savings."

Shared savings contracting for energy conservation was based on the concept that a contractor providing the capital investment to modify and/or construct and operate a facility could reduce energy consumption. The resulting savings would then be shared between the federal government and the private contractor in accordance with the terms of a multiyear contract. The agreement could be for the implementation of a single energy conservation measure or for several measures.<sup>24</sup> A contractor who successfully bid on a project could get back only a return on the investment if he or she were able to generate energy savings efficiently. The contractor's return on investment was in direct proportion to his or her ability to reduce consumption of energy. While such a commitment was obviously risky for the contractor, the Army served to gain from the arrangement, since it received the service yet did not guarantee the contractor's investment for money unless there were energy savings.<sup>25</sup>

The Department of Defense established a number of projects to test the shared savings concept. The U.S. Navy was the lead agency for the program. The Army was to conduct six pilot tests. Huntsville Division was directed to develop a method employing shared savings contracting. The Division was to provide managerial, technical, and contractual services

to the six pilot projects. Studies were conducted for the following installations: Corpus Christi Army Depot and Forts Bliss, Sam Houston, Shafter, Bragg, and Eustis. At Corpus Christi the project involved the installation and operation of a chiller. At Forts Bliss, Sam Houston, and Shafter the contracts dealt with multiple Energy Conservation Opportunities. One was for the William Beaumont Hospital at Fort Bliss, another was for the Medical Training Center and Administrative Office at Fort Sam Houston, and the third was for an Aliamanu Military Reservation Family Housing unit at Fort Shafter. Electrical peak shaving plants were to be installed and operated at Fort Eustis and Fort Bragg. By 1988, shared savings solicitations were either pending or in the process of materializing at all those installations.<sup>26</sup>

## Corps-Wide Computer-Aided Design and Drafting Procurement

Computer-Aided Design and Drafting (CADD) is a tool that related engineering design to graphic representation and to automated drafting and mapping work. It was intended to support architectural, engineering, planning, design, and construction procedures for military and civil works projects. One of the most important areas of automation support was CADD. Huntsville Division was the first among Corps agencies to implement CADD technology, and, in time, automation became inherent in successful mission accomplishment. A number of microprocessors were added to assist the Division in meeting both engineering and management needs. (In July 1978, a study was conducted investigating the use of computer-aided drafting for the preparation of civil engineering and master planning drawings.)

The investigation revealed that considerable savings could be realized by using computer graphics to prepare maps for the Sunflower Army Ammunition Plant master plan instead of the scribe-coating method. The investigation also revealed that the technology and the necessary equipment were available at the Army Missile Command at Redstone Arsenal in Huntsville. Huntsville Division personnel were given access to an Intergraph graphics computer at Redstone Arsenal during non-peak hours. In February 1981, Huntsville Division leased a PDP 11/44-based CADD system from the Integraph Corporation. In August 1984, the system was upgraded to a VAX 11/751-based system. In January 1986, before



Fig. 23. CADD in Operation

the original five-year contract expired, Huntsville Division purchased the equipment using accrued purchase option credits. During the original five-year period, the CADD system was used in the production of several designs and drawings most of which were concerned with the Range Modernization Program, commissaries, Marine Corps Ranges, mobilization designs, Strategic Defense support, Huntsville Division's new Training Center, Laser Program, Defense Reutilization and Marketing Service, RDX, and FEMA Keyworker Blast Shelters.<sup>27</sup>

In 1982, prompted by recommendations from Huntsville Division, the Corps of Engineers embarked upon a plan to purchase CADD equipment. Two years later HQUSACE established a nine-member team to study the question, the team finally concluding that buying a CADD system was more economical than leasing one.<sup>28</sup> Colonel Poteat was encouraged to see that the Corps was now moving ahead to fill the void with the purchase of CADD equipment. He offered the following advice:

Huntsville Division is pleased to be able to play a role in this procurement. As a note of caution, I believe the Corps' FOAs should all have the same system or at least compatible

systems to facilitate communications between different offices. I also believe we should consider having equipment that is widely used in the AE community so that we can achieve the benefits of compatibility in that direction.<sup>29</sup>

The Chief of Engineers agreed that there should be a standardized CADD system common to all Corps' agencies. A task force of CADD experts (Engineer Computer Concept and Applications Group) assembled from various Corps' offices indicated that there were several vendors who were able to meet Corps specifications and provide long term state-of-the-art service. They concluded that compatibility with the A-E community could be achieved.<sup>30</sup>

In a letter dated 25 June 1984, HQUSACE requested Huntsville Division act as a procurement agent for CADD and mandated the formation of a CADD Evaluation Team to participate in technical and benchmark evaluations. Technical and contracting personnel from several FOAs were included. Of the ten members, three were from the Huntsville Division. This team developed a specification for multiple procurement of CADD equipment. Procuring such equipment for Corps-wide use proved to be difficult and time-consuming because of the complexity of the system and the detailed documentation demanded by the Department of Defense. Frequently, the result was that equipment became obsolete by the time the procurement process was complete. It was said that the procurement cycle was four times the half-life of the technology.<sup>31</sup>

While the procurement of CADD equipment was facing some major slippage in the approval process, a number of field operating agencies either had or were in the process of obtaining interim CADD systems on a leased basis. Colonel Abbott was concerned that the interim, piecemeal effort could result in considerable loss of production caused by the incompatibility of the interim systems and the systems that were being procured. Other Corps agencies expressed similar concerns. Colonel Abbott felt that HQUSACE should give this problem its fullest attention.<sup>32</sup>

Headquarters, U.S. Army Corps of Engineers was aware of the problem facing CADD procurement and was making every effort to accelerate the approval process. In the meantime, Headquarters felt that the leasing of equipment under the criteria it had

established was the best interim solution to a difficult problem. Headquarters reminded Huntsville Division that all approvals for field operating agencies' leases were contingent upon safeguards designed to ensure compatibility of systems for the ultimate Corps-wide procurement.<sup>33</sup>

Formal approval and Delegation of Procurement Authority was obtained from the General Services Administration on 21 January 1986. Based on the results of evaluations, the contracting officer selected Intergraph Corporation of Huntsville, Alabama, as the contractor to supply the CADD system on a Corps-wide basis. A requirements contract estimated at \$33 million was awarded on 4 September 1987 for equipment for 30 FOAs.

The acquisition plan approved by the General Services Administration called for \$51 million for the Corps of Engineers, and an additional \$50 million for master planning activities and \$20 million for mobilization. The contract stated that additional offices could be allowed to use the contract with the approval of HQUSACE, Integraph Corporation, and the Contracting Officer. Huntsville's Contracting Division is the contract administration office for the contract, which has orders for more than \$20 million,

and now allows 38 Corps offices and approximately 130 non-Corps offices to use it.

After the contract was awarded, a meeting was held in Atlanta, Georgia, in order to familiarize the field operating agencies with the initial procurement. Huntsville Division's new system was to be the sixth system delivered. During the first year, the Engineering Division was scheduled to receive two graphic workstations, along with the delivery of the system's basic components.

The new system was expected to expand to 16 graphic workstations, which were intended to support Huntsville Division's engineering branches with discipline-oriented software designed for their use.

A team was also formed to develop a CADD implementation plan. The team consisted of individuals from each of the engineering branches that used the Intergraph system. The objectives of the plan were to develop strategies for the purchase of hardware and software and to integrate them with the existing CADD operations. The plan was to address such areas as CADD management, acquisition schedules, cost, training, and whatever hardware and software were needed. As the period of this history came to a close, the plan still awaited approval.<sup>34</sup>

# Corps Training and Training Management

Corps Training and Training Management is a mission that was transferred from HQUSACE to Huntsville Division in 1978. Through its Training Management Division, Huntsville Division provided the central management of the Proponent Sponsored Engineer Corps Training (PROSPECT). The Division planned, validated, and developed training programs, monitored contractor performance, and directed resident and nonresident training. The Training Management Division acted as registrar, conducted surveys, and requested and controlled allocations of military and civilian attendance at schools and courses operated by other agencies such as: the U.S. Army Training and Doctrine Command, Materiel Development and Readiness Command, Defense Management Education and Training, and the U.S. Army Deputy Chief of Staff for Personnel.

PROSPECT courses covered a wide spectrum of administrative and technical subjects. These subjects were developed to meet the specific needs of the Corps not available from other sources. The courses were generally presented in the traditional classroom -- lecture mode. Some courses were held at the Training Center in Huntsville, and others were taught at the most economical and strategic locations available throughout the United States and overseas. Students who attended the courses were usually from the Corps, but some were from other federal and state agencies. Instructors were Corps employees (past and present), universities, and contractors from private industry.

In March 1981, a new type of training was introduced known as Corps of Engineers Nontraditional Systems Training (CONTRAST). Because it was exportable and designed to be used by individuals, the new program added a significant amount of flexibility to the traditional methods of classroom training. Moreover, because training was given where the student worked, CONTRAST was cost effective. Additionally, CONTRAST was cost effective for subject areas that had many users but which changed little in

curriculum or course content. Study materials consisted largely of video tapes and supporting materials.<sup>1</sup>

The Chief of Engineers, Lieutenant General Joseph K. Bratton, was pleased with the progress made in training. He believed that the "combination of classroom and exportable training packages should provide a good mix to ensure that we achieve the optimum in numbers of well trained employees."<sup>2</sup>

Until 1987, the Training Center was located at a facility on North Memorial Parkway in Huntsville, but as discussed in Chapter II, a larger facility was built to house the Training Management Division and Training Center and was dedicated in January 1988.

The Division had improved internal management processes through organizational changes, employee development, and automation of registrar functions. In July 1987, the Training Management Division's three branches were reorganized into four. The three former branches -- the Training Operation Branch; Nontraditional Training Branch; and Support Branch to handle logistics, registrar, supplies, and other administrative functions -- were reformed into the Training and Operations Branch, the Nontraditional Training and Planning Branch, and the Training Assistance Branch. Then, a fourth branch was added -- the Corps Registrar Branch.

Huntsville Division's good reputation in training grew. A report issued by a HQUSACE inspection team in 1987 observed that the Corps training program was "well founded upon needed training, efficiently run, and properly managed." It also noted that both classroom and exportable courses were "properly focused and well utilized."<sup>3</sup>

## PROSPECT Training

From 1982 to 1987, there was an overall growth in the number of courses and sessions held in classroom

training and in the number of students attending those courses. The following table reflects the number of training sessions held during each fiscal year:

**Table 10**  
**Training Sessions (regular and on-site)<sup>4</sup>**

	Scheduled	Actual
FY 1982	232	241
FY 1983	381	389
FY 1984	400	404
FY 1985	402	411
FY 1986	476	439
FY 1987	403	392

The following table reflects the number of people that were trained under the PROSPECT program:

**Table 11**  
**Personnel Trained (regular and on-site)<sup>5</sup>**

	Scheduled	Actual
FY 1982	8,580	7,949
FY 1983	12,124	12,032
FY 1984	12,224	11,370
FY 1985	10,625	11,665
FY 1986	14,016	12,970
FY 1987	13,416	12,179

The actual number of students participating in classroom courses increased more than 53 percent during the years listed in the table. By 1987, there were about 700 to 750 Corps instructors participating in the program plus another 200 contract instructors. Furthermore, of the 234 courses in the program's inventory, about 160 were taught each year, with 15 to 20 percent of the courses held at the Training Center in Huntsville.<sup>6</sup>

The period 1982-1987 saw the introduction of new courses and the refinement of old ones. One of the highlights of the FY 1982 program was the development and presentation of one session of a Corps direct-funded course on cost reimbursement-type construction contracts. The manuals that were developed from that course were to be used throughout the Corps to assist in the management and administration of construction contracts

awarded on a cost reimbursement basis.<sup>7</sup>

A redesigned geology course, the result of a review by the Ad Hoc Committee for the Corps of Engineers' Geology Training Courses, was also presented in 1982 at the University of Missouri, Rolla. The university brought in internationally recognized experts from private industry as guest speakers. Because the course was so well received and comprehensive, the university determined that graduate credit could be earned for as many as 12 semester hours, depending upon the evaluating institution. Furthermore, the success of the course led to an advanced course, offered in 1983.<sup>8</sup>

Twice a year the Training Center and Headquarters, U.S. Corps of Engineers hosted the CE Commander's Course for newly assigned Corps district commanders. Two main subjects -- the Commander As Contracting Officer and The Commander As Manager, both essential to the efficient administration of a Corps district, were taught. Huntsville Division constantly reviewed the course and brought about several changes in instructional methods and course content. The changes placed less emphasis on lecturers and resulted in greater student participation. About 65 percent of the course is devoted to practical application workshops. Another innovation was the addition of district commanders as part of the instructional team. The changes that were made to the Commander's Course were not fully implemented until the October 1985 session; however, Huntsville Division did implement several of the changes in the June 1985 session, and the results were highly favorable. In later sessions, the students' reactions to the revised course also were favorable, and Lieutenant General E.R. Heiberg III, Chief of Engineers, who had personally attended one session, was extremely pleased.<sup>9</sup>

Two events occurred during the period of this history that involved the training of foreign nationals. In 1982, 50 South Korean architects and engineers received training at a cost of about \$600,000. The Training Center was assisted by the Waterways Experiment Station (WES), the Construction Engineering Research Laboratory (CERL), and the North Pacific Division (NPD). The training involved several PROSPECT courses, specialized courses tailored to meet Korean needs, and field visits with several Corps organizations. The Korean students trained seven weeks at the Training Center, six weeks at WES, CERL, and NPD, and six weeks at a contractor

training center in Troy, Ohio.<sup>10</sup>

In FY 1984, a training program was held for 11 engineers from the Republic of China. That training was coordinated with other Corps FOAs and the Bureau of Reclamation.<sup>11</sup>

Innovations in training methods continued at the Training Center. In FY 1984, the Training Center introduced to the classroom program a computer training center, including a dedicated laboratory with terminals contracted from the University of Alabama in Huntsville. That training center improved computer-aided instructions.<sup>12</sup>

Another innovation during this period was the use of tele-training to broadcast courses to several locations, thus reducing instructor travel. The television training concept was successfully used by the U.S. Army School of the Air, employing a satellite training network. It was decided to use the Contracting Officer Representative Course as a pilot. That course was generally taken by a large number of people and was one that could lend itself to a reliable test and evaluation. Under the tele-training pilot the instructor team would broadcast from studios at Redstone Arsenal to five separate locations. Technical problems and a revision of the contract management program caused this effort to be halted after the initial pilot.<sup>13</sup>

Recruiting the required number of instructors to teach courses was always a problem for the Training Center. The center borrowed many Corps employees from their organizations, using them as in-house instructors usually for not more than two weeks during the year, to teach PROSPECT courses. Although the need for instructors to teach a variety of courses was widely publicized by the Training Center each year, organizations were sometimes reluctant to release employees to serve as instructors because of other compelling reasons. Therefore, a HQUSACE inspection team recommended to the Chief of Engineers that he place strong emphasis on the instructor recruitment problem in his annual message to division commanders. The team also recommended that Huntsville Division reinstate the Certificate of Proficiency, which gave recognition to instructors in their work.<sup>14</sup>

A potential problem for the Training Management Division, "no shows," was actually a success story. The number of students who registered for courses but

did not attend remained at about 6 percent, lower than many service schools.<sup>15</sup>

The Training Management Division was active in evaluating and improving the Corps Training Program. Instructor and student critiques of courses were compiled and evaluated. The results were used to improve subject matter coverage, instructor performance, and classroom and sleeping room surroundings. Also during this timeframe, Huntsville training specialists became more involved in attending courses to actually evaluate both course content and instructor performance. A concerted effort was made during this period to train all Corps employees used as instructors in the Instructional Methods Course offered in Huntsville. This course was used to train instructors in such areas as: classroom management, development of lesson plans, course objectives, and practical exercises. The effort resulted in a more thoroughly trained, professional Corps instructor cadre.

## **Exportable Training**

### **(CONTRAST)**

On 15 March 1981, the Nontraditional Training and Planning Branch launched the Training Management Division into the business of producing exportable training packages. Those packages were designed to enable a large number of people to undergo training on-site and in a short time period, thus reducing travel and per diem costs. The Exportable Program, or CONTRAST Program, as it was sometimes called, offered an alternative to the rising cost of traditional classroom training in certain selected subject areas. Exportable training was also recognized as a means of meeting the demands of the Occupational Safety and Health Agency's (OSHA) mandatory requirements and the Army's mobilization training requirements.<sup>16</sup>

During the CONTRAST Program's development, priorities were established. First, mandatory and specialized training programs such as mobilization, OSHA, and the Full Time Equivalent (FTE) System were to be developed and adapted for exportable training packages. Then, PROSPECT courses were to be analyzed and adapted for exportable training packages. Finally, appropriate government and commercial training packages were to be evaluated and

acquired and made available to Corps divisions, districts, and laboratories.<sup>17</sup>

During the first year that exportable training was in effect, the Training Management Division produced an orientation in sound and slide format for Norton Air Force Base. Training Management also prepared an orientation of the Full Time Equivalent System on video tape, with accompanying materials, for Corps FOAs. The Pilot Video-Leasing Program, started during the first year as well, was centrally funded and made available to all Corps FOAs in the form of instructional video tape modules. By mid-1982, the OSHA Employee and First-Line Supervisor courses and four mobilization courses were well into the development process.<sup>18</sup>

Within the next two years, the Training Management Division made significant accomplishments in the program. It created standard operating procedures for developing exportable training packages. Those packages consisted of a video cassette production on three-quarter-inch u-matic video cassettes that were condensed to five- to ten-minute segments of audio-visual training material. The tape employed a Student Study Guide that summarized each audio-visual segment of the cassette. The guide also contained exercises for each segment, references, and suggested reading material. The tapes were supported by a Facilitator's Guide which provided the group leader with a step-by-step approach to training.<sup>19</sup>

Mobilization courses that were centrally funded were provided to the FOAs free of charge. In November 1982, Training Management developed and distributed two mobilization courses: the General Mobilization Module and the Military Construction Project Managers Course. The Training Management Division also established criteria for selecting methods of financial support for converting PROSPECT courses to the exportable training package concept.<sup>20</sup>

In order to improve upon its exportable courses on construction, the Training Center was able to draw from an invaluable Corps resource. By interviewing former Corps chiefs and incorporating them into exportable tapes, the center was able to furnish firsthand examples of actual cases to supplement theory and therefore lend credibility to the material. The interviews were used in mobilization and inspection courses.<sup>21</sup>

In response to Blue Ribbon Panel findings, the Training Management Division was directed to develop exportable training courses in the area of construction inspections. The first course, Construction Quality Management, was distributed to the field in March 1984. That course was so popular that it was reprinted and redistributed in July 1984 to a wider audience. The other inspection training packages that were later developed included Concrete Construction Inspection, Electrical Inspection, Mechanical Inspection, Paint Inspection, Refrigeration and Air-Conditioning Inspection, Flexible Pavement Inspection, and General Inspection.<sup>22</sup>

The CONTRAST Program would also be used to improve the PROSPECT Program, since the future of Corps training was to consist of a coordinated curriculum effort in both classroom, or traditional, training and exportable training courses. In its efforts to convert classroom courses to exportable training packages, Huntsville Division evaluated all classroom courses in order to determine what should be exportable and what should be taught in the classroom. In many cases, a more-advanced classroom course needed to present the latest course changes and state-of-the-art advances and to train facilitators. Huntsville Division's immediate plans were to develop a concentrated curriculum that focused on construction inspections, contract management and administration, and a curriculum of both classroom and exportable programs. A total analysis of the curriculum was necessary in order to avoid duplication and meet the needs of a diversified student body in a cost-effective manner. The exportable mode of training was intended to reach a large audience that needed the basics of the curriculum. The traditional classroom training could then focus on the more specialized aspects, or advanced areas, of the curriculum. By capitalizing on the best of both programs, the traditional classroom training would be enhanced with the proper use of exportable training. The end product was a more comprehensive coverage of the training program, reaching out to more of the Corps' people at a lower cost.

By the end of 1987, 13 training packages had been fielded and 10 more were under development. Those packages included mobilization courses, courses that were converted from PROSPECT to CONTRAST, and special programs. As many as 4,000 to 6,000 students were trained annually under the CONTRAST Program.<sup>23</sup>

## EPA Superfund Training

In FY 1982, the Training Management Division was tasked and funded to act as project manager for all Corps FOA's Superfund training. Superfund training was initiated to instruct Corps employees working for the Environmental Protection Agency (EPA) on superfunded clean-up sites. The EPA emergency response teams in ten regions provided identification, clean-up, and safety training courses to EPA employees, other federal employees, and state and local governments. Corps employees attended those courses in order to understand the superfund site better and improve design, writing of contracts, and inspection of a clean-up site.<sup>24</sup>

The Training Management Division was responsible for all logistical support to the Corps Superfund Training Program. It responded to the needs of Corps FOAs for spaces in approved courses. EPA funds were allocated to Corps employees for travel, per diem, and labor to attend training.

The Training Management Division was responsible for receiving feedback from a course's evaluation. As project manager, the Training Management Division updated and maintained the Superfund Course Catalog, which was the document from which FOAs planned their training curriculum on a project-by-project basis.

Each year Superfund functional and training officers received copies of the Superfund Training Plan. The first plan was published in October 1982, and it listed the responsibilities of the Office of the Chief of Engineers, Corps field offices, and the Training Management Division. The plan also listed courses available from the PROSPECT catalog and other government and private sources.

The 1983 Superfund Training Plan listed only the EPA courses and the Superfund Overview course. Those two sources were used from 1983 through 1987. Meanwhile, in 1984, a Superfund Section was added to the Purple Book, the official course catalog, that remained through 1987.<sup>25</sup>

Table 12 shows the types of Superfund courses offered from 1982 to 1987.<sup>26</sup>

The Superfund Overview course was offered each year from 1983 through 1987, employing EPA contractor and Corps instructors. From 1982 to 1987, about 540 Corps employees were trained in the EPA and Superfund Overview courses.<sup>27</sup>

## Mobilization Courses

Mobilization courses, like those courses associated with OSHA, were part of the CONTRAST Program. When CONTRAST training was first organized, emphasis was placed on the preparation of mobilization courses. In addition to the conversion of certain PROSPECT courses to the CONTRAST mode, the actual development of mobilization courses assumed a high priority in the Training Management Division. Emphasis on the development of mobilization courses was the direct result of the Chief of Engineers' challenge to the Corps "to reorder its priorities to assure that this command, at all levels, has properly and adequately resourced mobilization preparedness functions and activities."<sup>28</sup>

Eight mobilization courses were immediately scheduled for development by the end of September 1983. As an exportable package, each course was to consist of a Facilitator Guide, Video Content Carrier, Student Study Guide, and Job Performance Aid. The courses were intensive -- 20 to 24 hours in length -- and were to require trained instructors. The first four courses to be developed during FY 1982 were Real Estate Procedures for Mobilization, Military Construction and Project Management for Mobilization, Military Construction Surveillance, and Military Finance and Accounting Procedures.<sup>29</sup>

The Training Management Division designed the courses in order to train employees, who normally dealt with civil works projects, to transfer their skills to military projects in wartime. The mobilization courses combined the convenience of a video course and the learning experience gained through class interaction. The new courses were packaged with sufficient materials for 25 students. The courses lasted from 2-1/2 to 3 days. Many Huntsville Division employees took part in producing the video tapes, playing their usual work roles as project managers and supporting personnel.<sup>30</sup>

In addition to the four courses already cited, by the end of 1987, the following mobilization courses were developed and were being used throughout the Corps: Expediting Materials for Mobilization, Cost-Reimbursement Construction Contracts for Mobilization, Military Construction Design for Mobilization, and Project Security. In the meantime, there were at least three other courses under development. These were: Military Construction for Resident Engineers, Construction Contract Ad-

ministration, and Personnel Planning and Management.<sup>31</sup>

Judging from the favorable responses received from the field, there was little doubt that Mobilization Courses as exportable training proved to be a success. Feedback from the field indicated that benefits had exceeded expectations.<sup>32</sup>

In summing up the history of Corps training during

the period 1982-1987, one must conclude that Huntsville Division had made significant efforts to improve the program especially in the area of course management. The introduction and development of exportable training as well as other teaching innovations were significant factors in making Corps training available to a wider audience at reasonable cost. This effort spoke well for the future of the Corps training program at Huntsville Division.

# Conclusion

Huntsville Division's unique position in the Corps of Engineers continued to serve it well during the period of this history. Functioning strictly as an operating agency without geographical boundaries and districts, Huntsville Division was able to pursue an ever-growing number of highly technical missions. The same distinctive characteristics that led HQUSACE to assign the Ballistic Missile Defense (BMD) mission to Huntsville Division in the sixties also led that headquarters to assign a multiplicity of high-technology missions to the Division in later years. The experience gained early in its existence with acquiring Government Furnished Property (GFP) for the BMD mission, the Postal Service Bulk Mail Facilities, and Saudi Arabia missions made Huntsville Division the most logical Corps agency to assume similar missions in the eighties. The engineering technology of these missions included innovative methods of design and procurement in areas of major concern to the military and to the civilian populace.

By the end of 1987, the results of several of these missions were evident. Despite Congressional reduction in funds, the award of a major contract for the design of the Ground Based Free Electron Laser-Technology Integrated Experiment was a major contribution to the Strategic Defense Initiative.

One important achievement during this period of history was the completion of the Mississippi Army Ammunition Plant, the first plant of its kind to receive a completely new and modern facility. Huntsville Division was responsible for designing the plant, awarding the construction contract, and aiding in the contract's supervision. By the end of 1987, funding for the Munitions Production Base Support Construction Program (MPBSCP), which approached \$112 million, represented more than 40 percent of the Division's budget. There was little doubt that this program was to continue to receive the Division's attention well into the nineties.

The Chemical Demilitarization Program was second only to the MPBSCP in money spent and consisting of more than 22 percent of the Division's budget. By 1987, much had been accomplished to achieve a level of high technology in the destruction

of chemical agents. The completion of designs and the beginning of construction at Johnston Atoll and at other domestic installations occurred during the period. By the end of 1987, Huntsville Division was in the process of designing eight plants in the United States where chemical agents were scheduled for destruction.

Huntsville Division continued to successfully serve customers in the procurement of furnishings and medical engineering supplies for the Office of the Surgeon General and the Army Reserve Centers. These customers remained extremely satisfied with Huntsville Division's support. Furthermore, other potential customers were looking to the Division for similar support as 1987 came to a close.

The Corps continued to place confidence in the CE Training Program. The construction of a new and modern training facility in Huntsville, Alabama, during the period of this history is a tribute to the Division's efforts to conduct a more-effective training program.

Although it was yet too soon to draw any conclusions, the introduction of exportable courses in order to supplement classroom courses was beginning to show some promising results. Both HQUSACE and Huntsville Division were certain that this combination of courses would benefit and strengthen corps training.

Much of the credit for Huntsville Division's successes during the six years of this history must go to the Division's dedicated and highly motivated staff. The advanced technical missions assigned to the Division, a trend begun when the Division was first organized, continued to attract unusually high caliber employees.

As 1987 came to a close, Huntsville Division's future appeared to be bright. Although no one could predict world events nor the needs of the Defense Establishment with any great certainty, one could feel confident that there would be a need for an organization like Huntsville Division to conduct and coordinate work of a high technological nature with application not only in the Defense Establishment, its primary goal, but in a society devoted to peace.

# Notes

## CHAPTER 1

1. General Orders 17, HQUSACE, Oct. 1967.
2. Fact Sheet, HND, Training Management Program, 11 Jan. 1983, Historical Files, Huntsville Division. Hereafter collection cited as Historical Files, HND. Col. John A. Poteat to Senator Heflin's aide, draft of letter, c. 1982, Historical Files, HND.
3. For treatment of several of these programs, see Louise Schwallie Heidish, *A History of the Huntsville Division, U.S. Army Corps of Engineers, 1977-1981 Update* (Huntsville, AL: Huntsville Division, Corps of Engineers, 1983).
4. Col. John A. Poteat to Lt. Gen. Joseph K. Bratton, 11 Aug. 1983, Periodic Letters, Executive Office Files, Huntsville Division. Hereafter collection cited as Periodic Letters, HND. See also Command Briefing, "Introduction to Huntsville Division, USACE," 17 Nov. 1981, Historical Files, HND.
5. Col. John A. Poteat to Lt. Gen. Joseph K. Bratton, 16 July 1984, Periodic Letters, HND.
6. Interview, author with Col. John A. Poteat (Ret.). Huntsville, AL, 5 June 1988. Hereafter cited as Poteat interview.
7. Ibid.
8. Interview, author with Mr. Walter R. Peterson, retired Chief, Engineering Division, HND. Huntsville, AL, 3 June 1988. Hereafter cited as Peterson interview. Interview, author with Col. William A. Miller, Deputy Commander, HND. Huntsville, AL, 3 June 1988.
9. Division Historical Summary, FY 1982, Resource Management Office, HND, 11 Feb. 1983, Historical Files, HND.
10. Ibid.
11. ER-10-1-22, Organization and Functions: U.S. Army Engineer Division, Huntsville, 1 Mar. 1982.
12. ER-10-1-22, Organization and Functions: U.S. Army Engineer Division, Huntsville, 17 July 1987.
13. Ibid.
14. Ibid.
15. Draft of ER, Engineering and Design Corps -- Wide Technical Center of Expertise Assigned to Divisions and Districts, USACE, 1 Nov. 1984, Active Files, Management Analysis Branch, Resource Management Office, HND.
16. Unidentified document, "Huntsville Division Centers of Expertise," Active Files, Management Analysis Branch, Resource Management Office, HND.
17. Brig. Gen. C.E. Edgar to Commander, USACE, "Command Visit, U.S. Army Engineer Division, Huntsville, 16-18 March 1983," 19 Apr. 1983, Executive Office Files, HND.
18. Interview, author with Col. Rudolph E. Abbott (Ret.). Los Angeles, CA, 8 June 1988. Hereafter cited as Abbott interview.
19. Brig. Gen. George K. Withers, Jr. to Commander, USACE, "Command Visit, U.S. Army Engineer Division, Huntsville, 27-28 June 1984," 2 Aug. 1984, Executive Office Files, HND.
20. Brig. Gen. Peter J. Offringa to Commander, USACE, "Final Report of U.S. Army Engineer Division, Huntsville Command Inspection, 21-24 September 1987," 12 Nov. 1987, Executive Office Files, HND; Abbott interview; Peterson interview; Interview, author with Col. Robert S. Lindsay (Ret.). Huntsville, AL, 6 June 1988.
21. Col. Rudolph E. Abbott to Lt. Gen. E.R. Heiberg, III, Chief of Engineers, 13 Feb. 1986, Periodic Letters, HND.
22. Col. Rudolph E. Abbott to Lt. Gen. E.R. Heiberg, III, 29 Aug. 1986, Periodic Letters, HND.

## CHAPTER 2

1. Interview, author with Col. Rudolph E. Abbott (Ret.). Los Angeles, CA, 8 June 1988. Hereafter cited as Abbott interview.
2. Biographical Sketch, undated, supplied by Col. John A. Poteat, Jr., author's files.

3. Information Bulletin, HND, Vol. 7, July 1984, Historical Files, HND.
4. News Release, HND, undated, Historical Files, HND; Information Bulletin, HND, Vol. 6, June 1984, Historical Files, HND.
5. Information Bulletin, HND, Vol. VI, No. 1, Jan. 1987, Historical Files, HND.
6. Biographical Sketch, Col. Robert S. Lindsay, 16 Feb. 1987, Historical Files, HND; Information Bulletin, HND, Vol. VI, No. 1, Jan. 1987, Historical Files, HND.
7. Biography, Col. Charles T. Myers III, Mar. 1988, Historical Files, HND; News Release, HND, "Change of Command Set for Huntsville Division," Release No. 87-9, undated, Historical Files, HND.
8. Command Briefing, Revised, 9 Feb. 1982, Historical Files, HND.
9. Division Historical Summary, Resource Management Office, HND, 1983, Historical Files, HND.
10. Ibid.
11. Ibid.
12. Ibid.
13. Ibid.
14. Ibid.
15. Interview, author with Mr. Ralph Loschialpo, Director of Personnel, HQUSACE. Washington, D.C., 8 July 1988. Hereafter cited as Loschialpo interview.
16. Ibid.; Col. John A. Poteat to Lt. Gen. Joseph K. Bratton, c. 1983, Periodic Letters, Executive Office Files, HND. Hereafter collection cited as Periodic Letters, HND.
17. Abbott interview; Memorandum, Col. Rudolph E. Abbott to staff, subject: "Provisional Reorganization of Engineering Division and Systems Engineering Division," 15 Jan. 1986, w/encl., Historical Files, HND.
18. State of the Division, Briefing by Col. Rudolph E. Abbott, c. Oct. 1986, Historical Files, HND.
19. Information Bulletin, HND, Vol. V, No. 7, July 1986, Historical Files, HND.
20. Memorandum, Brig. Gen. Peter J. Offringa to Commander, USACE, subject: "Final Report of U.S. Army Engineer Division, Huntsville, Command Inspection, 21-24 September 1987," 12 Nov. 1987, Executive Office Files, HND. Hereafter cited as Offringa, Final Report of Inspection, 12 Nov. 1987.
21. Memorandum, Brig. Gen. George K. Withers, Jr. to Commander, USACE, subject: "Command Visit, U.S. Army Engineer Division, Huntsville, 27-29 June 1984," Executive Office Files, HND.
22. Offringa, Final Report of Inspection, 12 Nov. 1987.
23. Statistics compiled from the Program Review and Analysis, HND, for each 4th quarter, FYs 1982-1987, Historical Files, HND.
24. Table extracted from Program Review and Analysis, HND, 1st quarter, FY 1988, p. 38.
25. Abbott interview.
26. Interview, author with Col. William A. Miller, Deputy Commander, HND. Huntsville, AL, 3 June 1988. Hereafter cited as Miller interview.
27. Col. John A. Poteat to Lt. Gen. Joseph K. Bratton, Chief of Engineers, 19 May 1982, Periodic Letters, HND.
28. Col. John A. Poteat to Lt. Gen. Joseph K. Bratton, 14 Feb. 1983, Periodic Letters, HND.
29. Lt. Gen. Joseph K. Bratton to Col. Rudolph E. Abbott, 10 Sept. 1984, Periodic Letters, HND.
30. State of the Division, HND, FY 1986, Historical Files, HND.
31. Interview, author with Mr. Walter R. Peterson, former Chief, Engineering Division, HND. Huntsville, AL, 3 June 1988. Hereafter cited as Peterson interview. Interview, author with Mr. Al Henderson, Deputy Chief, Engineering Division, HND. Huntsville, AL, 7 June 1988; Loschialpo interview; Abbott interview; Miller interview.
32. Abbott interview; Peterson interview.
33. State of the Division, c. 1986 Historical Files, HND.
34. Col. Rudolph E. Abbott to Lt. Gen. E.R. Heiberg III, 25 Feb. 1985, Periodic Letters, HND.
35. Lt. Gen. E.R. Heiberg III to Col. Rudolph E. Abbott, 6 May 1985, Periodic Letters, HND.
36. Disposition Form, John H. Brown, EEO Officer, HND, to DA, HND, subject: "The Chief's Tri-

- annual Letter," 10 May 1982, Periodic Letters, HND.
37. Ibid.
  38. Offringa, Final Report of Inspection, 12 Nov. 1987.
  39. Program Review and Analysis, HND, 1st quarter, FY 1988, p. 2.
  40. State of the Division, c. 1985-86, Historical Files, HND.
  41. Abbott interview.
  42. Fact Sheet, "CE Training Center," Issue No. 19, Updated, 22 Apr. 1988, Historical Files, HND.
  43. Interview, author with Mr. Emmett N. Creekmore, Chief, CE Training Management Division, HND. Huntsville, AL, 13 June 1988; Fact Sheet, Training Management Program, c. 1982, Historical Files, HND.
  44. Interview, author with Mr. Gerald D. Dupree, Chief, Management Analysis Branch, Resource Management Office, HND. Huntsville, AL, 15 June 1988. Mr. Dupree was the Huntsville Division's representative in all negotiations with the university dealing with the new facility.
  45. Ibid.
  46. Ibid.
  47. Information Bulletin, HND, Vol. V, No. 2, Feb. 1986, Historical Files, HND.
  48. Information Bulletin, HND, Vol. V, No. 3, Mar. 1986, Historical Files, HND.
  49. Fact Sheet, "CE Training Center," 31 July 1988, Issue No. 19, Updated, 22 Apr. 1988, Historical Files, HND.
  50. Poteat interview; Peterson interview; Interview, author with Col. Robert S. Lindsay (Ret.). Huntsville, AL, 6 June 1988.
  51. State of the Division, c. 1987, Historical Files, HND.
  52. Statistics compiled from Program Review and Analysis, HND, for each 4th quarter, FYs 1982-1987.
  53. Program Review and Analysis, HND, 4th quarter, FY 1982, p. 1.
  54. Program Review and Analysis, HND, 4th quarter, FY 1984, p. 1.
  55. Program Review and Analysis, HND, 4th quarter, FY 1985, p. 1.
  56. Program Review and Analysis, HND, 4th quarter, FY 1986, p. 1.
  57. Program Review and Analysis, HND, 4th quarter, FY 1987, p. 1.
  58. Statistics compiled from Program Review and Analysis, HND, for each 4th quarter, FYs 1982-1987.
  59. Program Review and Analysis, HND, 4th quarter, FY 1982, p. 1.
  60. Program Review and Analysis, HND, 4th quarter, FY 1983, p. 1.

### CHAPTER 3

1. Col. John A. Poteat to Lt. Gen. Joseph K. Bratton, Chief of Engineers, 21 Jan. 1982, Periodic Letters, Executive Office Files, HND. Hereafter collection cited as Periodic Letters, HND.
2. Fact Sheet, subject: "U.S. Army Strategic Defense Command (USASDC) Program (formerly called Ballistic Missile Defense (BMD))." Issue No. 27, Updated 22 Apr. 1988, Historical Files, HND.
3. Fact Sheet, subject: "Advanced Technology Activity," Issue No. 3, Updated 22 Apr. 1988, Historical Files, HND.
4. Ibid.
5. Ibid.
6. Fact Sheet, subject: "Ground Based Free Electron Laser- Technology Integrated Experiment (GBFEL-TIE)," Issue No. 10, Updated 29 Apr. 1988, Historical Files, HND.
7. Anonymous, "Corps Starts Star Wars Work," Engineering News -- Record, 217 (11 Dec. 1986): p. 16.
8. Ibid.; Interview, author with Mr. Al Henderson, Deputy Chief, Engineering Division, HND. Huntsville, AL, 7 June 1988. Hereafter cited as Henderson interview. Nita Mallett, "Fort Worth, Huntsville to Put Up Laser Facility," Engineer Update," 11 (Sept. 1987).
9. Henderson interview.
10. Pie Graph, "FY-88 Key Programs," May 1988; FY 1987 Program and Fund Status, as of Sept. 1987, Resource Management Office, HND. Hereafter

cited as Program and Fund Status.

11. Memorandum, Maj. Gen. Drake Wilson to Commander, USACE, subject: "Command Inspection, U.S. Army Engineer Division, Huntsville, 6-7, April 1981," 13 May 1981, Executive Office Files, HND.

12. Fact Sheet, subject: "Power Reliability Enhancement Program (PREP)," Issue No. 4, Updated 31 Oct. 1982, Historical Files, HND. Hereafter cited as Fact Sheet, 31 Oct. 1982.

13. Ibid.

14. Ibid.

15. Ibid.; Col. John A. Poteat to Lt. Gen. Joseph K. Bratton, 21 Jan. 1982, Periodic Letters, HND.

16. Fact Sheet, 31 Oct. 1982.

17. Fact Sheet, subject: "Power Reliability Enhancement Program (PREP)," Issue No. 22, Updated 29 Apr. 1988, Historical Files, HND. Hereafter cited as Fact Sheet, "PREP;" 29 Apr. 1988.

18. Ibid.

19. Ibid.; Program Fact Sheet, "Power Reliability Enhancement Program (PREP), No. 12, Sept. 1984, Historical Files, HND.

20. Fact Sheet, "PREP" 29 Apr. 1988.

21. Figures for estimated man years and funds derived from the Program and Fund Status, FYs 1983 through 1987, Resource Management Office, HND.

22. Program Fact Sheet, HND, Apr. 1982, Historical Files, HND.

23. Fact Sheet, subject: "AFCS," Issue No. 28, Updated 29 Apr. 1988, Historical Files, HND. Hereafter cited as Fact Sheet, "AFCS," 29 Apr. 1988.

24. Command Briefing, Revised 9 Feb. 1982, Historical Files, HND.

25. Disposition Form, Chief, Engineering Division, HND, to Public Affairs Officer, HND, subject: "Division Historical Summary FY 82," 1 Mar. 1983, Historical Files, HND.

26. Program Fact Sheet, HND, "Army Facilities Components System (AFCS)," No.2, July 1984, Historical Files, HND.

27. Fact Sheet, "AFCS," 29 Apr. 1988.

28. Fact Sheet, subject: "FEMA Key Worker Blast

Shelter (KWBS) Program," Issue No. 23, Updated 29 Apr. 1988, Historical Files, HND.

29. Ibid.

30. Julian S. Hamilton, Jr., Structural Engineer, HND, "Review of the Status of the FEMA Key Worker Blast Shelter Program -- Up date of Research Results and Multiple Shelter Designs," a paper presented at the Corps of Engineers Engineering Conference, St. Louis, MO, 27 June -- 1 July, 1988, original copy in Mr. Hamilton's possession.

31. Ibid.

32. Figures derived from the Program and Fund Status, FYs 1982- 1987.

33. Command Briefing, Revised 9 Feb. 1982, Historical Files, HND.

34. Graph, "FY 88 Key Programs, May 1988, prepared by the Resource Management Office, HND; Chart, "Production Base Support Program," May 1988, prepared by the Resource Management Office, HMD; Program and Fund Status, FYs 1982-1987.

35. "Significant accomplishments during FY 84," undated, Historical Files, HND.

36. Paul M. Lahoud, "Use of Precast Concrete In Hardened Buildings at Mississippi AAP," Technical Report, HND Conference Paper, Minutes of the Twentieth Explosives Safety Seminar, 24-26 Aug. 1982, Technical Library, HND.

37. Interview, author with Col. John A. Poteat (Ret.), former Division Commander, HND. Huntsville, AL, 6 June 1988.

38. Program Fact Sheet, HND, No. 11, Apr. 1982, Historical Files, HND.

39. Fact Sheet, subject: "RDX/HMX Expansion Program," Issue No. 16, Updated 22 Apr. 1988, Historical Files, HND.

40. State of the Division, undated, c. 1986, Historical Files, HND.

41. Col. Michael Volpe, Executive Director, Directorate of Military Programs, HQUSACE, to Commander, North Atlantic Division, et al., 4 Sept. 1981, Active Files, Resource Management Office, HND.

42. Program and Fund Status, FYs 1982-1987.

43. Command Briefing, HND, Revised 9 Feb.

1982, Historical Files, HND. See Chapter IV for a discussion of the 1391 Processor System.

44. Command Briefing, HND, Revised 25 Oct. 1983, Historical Files, HND.

45. Program and Fact Sheet, HND, No. 13, Apr. 1986, Historical Files, HND.

46. State of the Division, HND, c. 1986, Historical Files, HND.

47. Fact sheet, subject: "Range Modernization," Issue No. 27, Updated, 29 Apr. 1988, Historical Files, HND.

## CHAPTER 4

1. Program Fact Sheet, "Environmental Audits for Army Materiel Command," No. 27, Jan. 1985, Historical Files, HND

2. Louise Schwallie Heidish, A History of the Huntsville Division, U.S. Army Corps of Engineers, 1977-1981 Update (Huntsville, AL: 1982), p. 30.

3. Program Fact Sheet, "Army Pollution Abatement Program (APAP)," No. 3, Apr. 1982, Historical Files, HND.

4. Ibid.; Command Briefing: Introduction to Huntsville Division, U.S. Army Corps of Engineers, c. 1981, Historical Files, HND.

5. Command Briefing: Introduction to Huntsville Division, U.S. Army Corps of Engineers, Revised 20 Apr. 1984, Historical Files, HND.

6. Interview, author with Col. William A. Miller, Deputy Commander, HND. Huntsville, AL, 3 June 1989. Hereafter cited as Miller interview. Interview, author with Col. John A. Poteat, former Commander, HND. Huntsville, AL, 6 June 1989. Hereafter cited as Poteat interview. Interview, author with Mr. Al Henderson, Deputy Chief, Engineering Division, HND. Huntsville, AL, 7 June 1989. Hereafter cited as Henderson interview.

7. Memorandum for the Commander, USACE, subject: "Command Visit, US Army Engineer Division, conducted during the period 16- 18 March 1983," from Brig. Gen. C.E. Edgar III, 19 Apr. 1983, Executive Office Files, HND.

8. Command Briefing, Revised 9 Feb. 1982, Historical Files, HND; Program Fact Sheet, "Environmental Support for the Army Materiel Command,"

No. 5, 5 Dec. 1985, Historical Files, HND. Col. John A. Poteat to Lt. Gen. Joseph H. Bratton, 21 Jan. 1982, Periodic Letters, Executive Office Files, HND. Hereafter collection cited as Periodic Letters, HND.

9. Program Fact Sheet, "Environmental Audits for Army Materiel Command," No. 27, Jan. 1985, Historical Files, HND.

10. Fact Sheet, subject: "Pollution Abatement," Updated 31 July 1982, Historical Files, HND.

11. News Release, HND, "Anniston Hazardous Waste Removal Contract Award," Release No. 82-9, Historical Files, HND.

12. State of the Division, HND, c. 1987, Historical Files, HND; News Release, HND, Release No. 86-3, Historical Files, HND; Information Bulletin, HND, Vol. V, No. 9, Sept. 1986, Historical Files, HND.

13. Information Bulletin, HND, Vol. III, Aug. 1984; Information Bulletin, HND, Vol. IV, No. 8, Aug. 1985, both documents in Historical Files, HND.

14. Ibid.

15. Col. Robert S. Lindsay, former Commander, HND, Speech for Awards Day at Alabama A&M University, 16 Apr. 1987, Historical Files, HND.

16. Fact Sheet, subject: "Defense Environmental Restoration Program (DERP)," Issue No. 17, Updated 29 Apr. 1988, Historical Files, HND.

17. Ibid.

18. Ibid.

19. Fact Sheet, subject: "Defense Logistics Agency (DLA) -- Installation Restoration Program (IRP)," Issue No. 10, Updated 29 Apr. 1988, Historical Files, HND.

20. Ibid.

21. Ibid.

22. Fact Sheet, subject: "Defense Reutilization and Marketing Service (DRMS)--Conforming Storage Program," Issue No. 16, Updated 29 Apr. 1988, Historical Files, HND.

23. Ibid.

24. Program Fact Sheet, "Support to Office of Program Manager for Chemical Munitions," No. 17, Jan. 1987, Historical Files, HND; Fact Sheet, subject: "Support to U.S. Army Toxic and Hazardous Materials Agency (USATHAMA) Program for

Demilitarization of Lethal Chemical Munitions," Issue No. 7, Updated 31 Oct. 1982, Historical Files, HND. Hereafter cited as Fact Sheet, Support to USATHAMA, Issue No. 7, 31 Oct. 1982.

25. Boyce L. Ross, Structural Engineer, HND, "Structural Engineering Problems: The Chemical Stockpile Disposal Program," a paper presented at the Annual Corps of Engineers Conference in St. Louis, MO, 27 June -- 1 July 1988. Hereafter cited as Ross, Chemical Stockpile Disposal Program. The author is grateful to Mr. Ross for making this data available to him.

26. Fact Sheet, Support to USATHAMA, Issue No. 7, 31 Oct. 1982. Johnston Atoll, or Johnston Island as it was sometimes called, was located 720 miles southwest of Hawaii, lying in a remote part of the Pacific Ocean. The atoll contained a large stockpile of chemical munitions removed from Okinawa in the 1970s.

27. Interview, author with Lt. Col. John McIlrath, Assistant Commander, HND. Huntsville, AL, 14 June 1988. Hereafter cited as McIlrath interview. Information Bulletin, HND, Vol. 4, Apr. 1982, Historical Files, HND.

28. McIlrath interview; Program Fact Sheet, HND, "U.S. Army Toxic and Hazardous Materials Agency (USATHAMA)," No. 17, Apr. 1982, Historical Files, HND.

29. DF, Walter R. Peterson, Chief, ED, HND, to Public Affairs Officer, HND, subject: "Division Historical Summary, FY 82," 1 Mar. 1983, Historical Files, HND. Hereafter cited as EDHND, Division Historical Summary, FY 1982.

30. State of the Division, Revised 23 Feb. 1982, Historical Files, HND.

31. EDHND, Division Historical Summary, FY 1982; "Significant Accomplishments During FY 84," undated, Historical Files, HND.

32. News Release, HND, Release No. 84-5, 6 Sept. 1984; McIlrath interview; State of the Division, HND, c. 1986, Historical Files, HND.

33. McIlrath interview; State of the Division, c. 1986, Historical Files, HND.

34. State of the Division, c. 1986, Historical Files, HND.

35. "Significant Accomplishments During FY-84," undated, Historical Files, HND.

36. McIlrath interview.

37. Fact Sheet, subject: "Support to the Office of the Program Executive Officer -- Program Manager for Chemical Demilitarization (PEO-PM-Cml Demil). . .," Issue No. 27, Updated 29 Apr. 1988, Historical Files, HND; Chemical Stockpile Disposal Program: Implementation Plan, 15 March 1988, Program Executive Officer -- Program Manager for Chemical Demilitarization, Aberdeen Proving Ground, MD, copy made available to the author by Lt. Col. John McIlrath; McIlrath interview.

38. McIlrath interview,

39. Louise Schwallie Heidish, A History of the Huntsville Division, U.S. Army Corps of Engineers, 1977-1981 Update (Huntsville, AL: Corps of Engineers, 1982), p. 33.

40. EDHND, Division Historical Summary, FY 1982, Historical Files, HND; Program Fact Sheet, HND, No. 6, Apr. 1982, Historical Files, HND.

41. Col. John A. Poteat to Lt. Gen. Joseph K. Bratton, 16 July 1984, Periodic Letters, HND; Lt. Gen. Joseph K. Bratton to Col. Rudolph E. Abbott, 10 Sept. 1984, Periodic Letters, HND

42. Program Fact Sheet, HND, No. 6, Nov. 1986, Historical Files, HND.

43. Col. John A. Poteat to Lt. Gen. Joseph K. Bratton, 21 Jan. 1982, Periodic Letters, HND; Fact Sheet, subject: "Computer Aided Engineering and Architectural Design System (CAEADS)," Issue No. 9, Updated 31 Oct. 1982, Historical Files, HND; Fact Sheet, subject: "Computer Aided Cost Estimating System (CACES)," Issue No. 13, Updated 29 Apr. 1988, Historical Files, HND. Hereafter cited as Fact Sheet, CACES, Issue No. 13.

44. Fact Sheet, CACES, Issue No. 13; News Release, HND, Release No. 83-5, "Computer Aided Cost Estimating System (CACES)," Historical Files, HND.

45. EDHND, Division Historical Summary, FY 1982; News Release, HND, Release No. 83-5, Historical Files, HND.

46. Fact Sheet, subject: "DD Form 1391 Process or System," Issue No. 12, Updated 29 Apr. 1988, Historical Files, HND. Hereafter cited as Fact Sheet, DD Form 1391, Issue No. 12.

47. Col. John A. Poteat to Lt. Gen. Joseph K. Bratton, 21 Jan. 1982, Periodic Letters, HND.

48. Fact Sheet, subject: "Computer Aided Engineering and Architectural Design System (CAEADS)," Issue No. 9, Updated 31 Oct. 1982, Historical Files, HND.
49. Ibid.
50. Fact Sheet, DD Form 1391, Issue No. 12.
51. Ibid.
52. Command Briefing: Introduction to the Huntsville Division, U.S. Army Corps of Engineers, c. 1981, Historical Files, HND; Command Briefing, Revised 9 Feb. 1982, Historical Files, HND.
53. Fact Sheet, subject: "Criteria Documents Update Program," Issue No. 9, Updated 31 Oct. 1982, Historical Files, HND.
54. EDHND, Division Historical Summary, FY 1982.
55. State of the Division, HND, c. 1986, Historical Files, HND.
56. Fact Sheet, subject: "Criteria Documents Update Program," Issue No 26, Updated 29 Apr. 1988, Historical Files, HND.
57. Fact Sheet, subject: "Economic Analysis System (ECONPACK)," Issue No. 11, Updated 29 Apr. 1988, Historical Files, HND; State of the Division, HND, c. 1986, Historical Files, HND.
58. Fact Sheet, subject: "Economic Analysis System (ECONPACK)," Issue No. II, Updated 29 Apr. 1989, Historical Files, HND.
59. Ibid.
60. Ibid.
61. Fact Sheet, subject: "DOD Operational Security Test Site, Ft. McClellan, AL," Issue No. 6, 31 July 1982, Historical Files, HND; Program Fact Sheet, HND, No. 15, Oct. 1984, Historical Files, HND.
62. EDHND, Division Historical Summary, FY 1982.
63. Maj. Gen. Mark J. Sisinyak, Assistant Commander, HQUSACE, to Commander, HND, subject: "Intrusion Detection Systems (IDS) Technical Center of Expertise (TCX) and Design Center," 4 Dec. 1984, Active Files, Resource Management Office, HND.
64. Fact Sheet, subject: "Intrusion Detection Systems (IDS)," Issue No. 18, Updated 29 Apr. 1988, Historical Files, HND.
65. State of the Division, HND, c. 1986, Historical Files, HND.
66. Ibid.
67. Col. John A. Poteat to Lt. Gen. Joseph K. Bratton, 16 July 1984, Periodic Letters, HND.
68. Lt. Gen. Joseph K. Bratton to Col Rudolph E. Abbott, 10 Sept. 1984, Periodic Letters, HND.
69. Col. Rudolph E. Abbott to Lt. Gen E.R. Heiberg III, Chief of Engineers, 25 Feb. 1985, Periodic Letters, HND.
70. Col. Rudolph E. Abbott to Lt. Gen. E.R. Heiberg III, 21 Aug 1985, Periodic Letters, HND.
71. Interview, author with Col. William A. Miller, Deputy Commander, HND. Huntsville, AL, 3 June 1989; Fact Sheet, subject: "Space Command Support," Issue No. 8, Updated 29 Apr. 1988, Historical Files, HND.
72. EDHND, Division Historical Summary, FY 1982; Fact Sheet, subject: "Mobilization Designs ('M' Designs)," Issue No. 25, Updated 29 Apr. 1988, Historical Files, HND. Hereafter cited as Fact Sheet, Mobilization Designs, Issue No. 25.
73. Fact Sheet, Mobilization Designs, Issue No. 25.
74. Anonymous, "Building Bit by Bit," Military Review 62 (Sept. 1982): 71.
75. Fact Sheet, Mobilization Designs, Issue No. 25.
76. Mr. William N. McCormich, Jr., Chief, Engineering Division, Directorate of Engineering and Construction, HQUSACE, to Commander, HND, subject: "Technical Assistance to FOAs for Child Development Facilities," 21 Jan. 1986, Active Files, Resource Management Office, HND
77. State of the Division, HND, c. 1986, Historical Files, HND.
78. Ibid.
79. Fact Sheet, subject: "Support to the Engineer Topographic Laboratory (ETL)," Issue No. 7, Updated 31 Oct. 1992, Historical Files, HND; Fact Sheet, subject: "Support to the USACE Engineer Topographic Laboratory (ETL)," Issue No. 28, Updated 29 Apr. 1988, Historical Files, HND.
80. Ibid.

81. State of the Division, HND, c. 1986, Historical Files, HND.
82. Fact Sheet, subject: "EMP/TEMPEST Support," Issue No. 10, Updated 29 Apr. 1988, Historical Files, HND.
83. Ibid.
84. Mr. David R. Brigham, Chief, Army Branch, Construction Division, HQUSACE, to Commander, HND, subject: "Repair of Railroads to Support RDF-A," 10 Aug. 1981, Brig. Gen. Mark J. Sisinyak, HQUSACE, to Commander, FORSCOM, subject: "Repair of Railroads to Support RDF-A," 23 July 1981. Both letters in Active Files, Resource Management Office, HND.
85. EDHND, Division Historical Summary, FY 1982; Command Briefing, Revised 9 Feb. 1982, Historical Files, HND.
86. EDHND, Division Historical Summary, FY 1982.
87. Ibid.
88. Significant Accomplishments During FY-84, undated, Historical Files, HND; Program Fact Sheet, No 9, Aug. 1985, Historical Files, HND.
89. Ibid.
90. Henderson interview; Command Briefing: Introduction to the Huntsville Division U.S. Army Corps of Engineers, Revised 20 June 1984, Historical Files, HND.
91. Mr. Charles D. Smith, Deputy Director, Technology and Engineering, Directorate of Military Programs, HQUSACE, to Division Engineers, subject: "Designation and Clarification of the U.S. Army Corps of Engineers Responsibilities Regarding Energy Monitoring and Control Systems," 7 June 1979, Active Files, Resource Management Office, HND.
92. Col. John A. Poteat to Lt. Gen. Joseph K. Bratton, 21 Jan. 1982, Periodic Letters, HND; Command Briefing: Introduction to the Huntsville Division U.S. Army Corps of Engineers, Revised 20 -- June 1984, Historical Files, HND; Program Fact Sheet, HND, No. 8, Jan. 1988, Historical Files, HND.
93. Energy User News, Vol. 9, 25 June 1984, p. 1
94. Energy User News, 9 (23 July 1984): 7.
95. Fact Sheet, subject: "Energy Monitoring and Control Systems (EMCS)," Issue No. 28, Updated 29 Apr. 1988, Historical Files, HND.
96. Ibid.
97. Fact Sheet, subject: "Energy Monitoring and Control Systems (EMCS)," Issue No. 28, Updated 29 Apr. 1988, Historical Files, HND; Memorandum for the Commander, HQUSACE, from Brig. Gen. Peter J. Offringa, subject: "Final Report of U.S. Army Engineer Division, Huntsville, Command Inspection, 21-24 September," 12 Nov. 1987, Executive Office Files, HND; Henderson interview.
98. Maj. Gen. William R. Wray, Director of Military Programs, HQUSACE, to Division Engineer, HND, subject: "Energy Engineering Analysis (EEA) Program," 13 Sept. 1979, Active Files, Resource Management Office, HND; Command Briefing: Introduction to the Huntsville Division U.S. Army Corps of Engineers, c. 1980, Historical Files, HND.
99. Fact Sheet, subject: "Energy Engineering Analysis Program (EEAP)," Issue No. 7, Updated 31 Oct. 1992, Historical Files, HND.
100. Information Bulletin, HND, Vol, III, No. 10, Oct. 1984, Historical Files, HND.
101. Program Fact Sheet, HND, No. 7, July 1985; Historical Files, HND.
102. Fact Sheet, subject: "Energy Engineering Analysis Program (EEAP)," Issue No. 28, Updated 29 Apr. 1988, Historical Files, HND.
103. Ibid.
104. State of the Division, HND, Revised 23 Feb. 1982, Historical Files, HND.
105. Fact Sheet, subject: "Solid Fuel Conversion Program (SFCP)," Issue No. 6, Updated 31 Oct. 1982, Historical Files, HND.
106. Program Fact Sheet, HND, No. 14, Dec. 1986, Historical Files, HND.

## CHAPTER 7

1. Program Fact Sheet, HND, "Government Furnished Property," No. 20, Jan. 1985, Historical Files, HND. Hereafter cited as Program Fact Sheet, "Government Furnished Property."
2. Ibid.; Command Briefing, Col. Lacey's Version,

Revised 25 Oct. 1983, Historical Files, HND; Command Briefing: Introduction to the Huntsville Division, U.S. Army Corps of Engineers, Revised 20 June 1984, Historical Files, HND.

3. Interview, author with Mr. Jim Vincent, Army Branch, Construction Division, HQUSACE, Washington, D.C., 8 July 1988. Hereafter cited as Vincent interview.

4. Interview, author with Col. Robert S. Lindsay, former Acting Commander, HND, Huntsville, AL, 6 June 1988; Interview, author with Col. Rudolph E. Abbott, former Commander, HND, Los Angeles, CA, 8 June 1988; Interview, author with Mr. Raymond D. Aldridge, Chief, Contracting Division, HND, Huntsville, AL, 9 June 1988. Hereafter cited as Aldridge interview.

5. Program Fact Sheet, HND, "Support to the Office of the Surgeon General," No. 24, Aug. 1984, Historical Files, HND. Hereafter cited as Program Fact Sheet, Support to the OTSG.

6. Ibid.

7. Ibid.; Program Fact Sheet, "Government Furnished Property."

8. Program Fact Sheet, Support to the OTSG.

9. Ibid.

10. Command Briefing, HND, Revised 9 Feb. 1982, Historical Files, HND; Chart, HND, "Surgeon General Procurement Support," May 1988, Active Files, Resource Management Office, HND.

11. Program Fact Sheet, Support to the OTSG; Disposition Form, Comment No. 2, Raymond D. Aldridge to Public Affairs Officer, subject: "Historical Report, Fact Sheets, Documents for 1983," 26 Jan. 1984, Historical Files, HND.

12. Vincent interview; Aldridge interview.

13. Program Fact Sheet, HND, "Third Party Contracting," No. 28, Jan. 1987, Historical Files, HND. Hereafter cited as Program Fact Sheet, "Third Party Contracting," Jan. 1987. Command Briefing: Introduction to the Huntsville Division, U.S. Army Corps of Engineers, Revised 20 June 1984, Historical Files, HND. Hereafter cited as Command Briefing, 20 June 1984.

14. Maj. Gen. Ames S. Albro, Jr., HQUSACE, to Commander, HND, subject: "Third Party Contracting," 11 July 1983, Active Files, Resource Manage-

ment Office, HND.

15. Program Fact Sheet, "Third Party Contracting," Jan. 1987.

16. Col. John A. Poteat to Lt. Gen. Joseph K. Bratton, 14 Feb. 1984, Periodic Letters, Executive Office Files, HND. Hereafter collection cited as Periodic Letters, HND.

17. Lt. Gen. Joseph K. Bratton to Col. John A. Poteat, 29 Mar. 1984, Periodic Letters, HND.

18. Command Briefing, 20 June 1984.

19. Col. Rudolph E. Abbott to Lt. Gen. E.R. Heiberg, III, 21 Aug. 1985, Periodic Letters, HND.

20. Program Fact Sheet, "Third Party Contracting," Jan. 1987.

21. Fact Sheet, subject: "Third Party Contracting (TPC)," Issue No. 18, Updated 29 Apr. 1988, Historical Files, HND. Hereafter cited as Fact Sheet, "Third Party Contracting," 29 Apr. 1988.

22. Ibid.; Col. Rudolph E. Abbott to Lt. Gen. E.R. Heiberg, III, 14 Feb. 1987, Periodic Letters, HND.

23. Fact Sheet, "Third Party Contracting," 29 Apr. 1988.

24. Fact Sheet, subject: "Shared Saving Contracting," Issue No. 13, Updated 29 Apr. 1988, Historical Files, HND. Hereafter cited as Fact Sheet, "Shared Savings Contracting."

25. Aldridge interview.

26. Fact Sheet, "Shared Savings Contracting."

27. Fact Sheet, subject: "Computer Graphics," Issue No. 18, Updated 18 Apr. 1988, Historical Files, HND. Hereafter cited as Fact Sheet, "Computer Graphics." State of the Division, HND, c. 1986, Historical Files, HND.

28. Terri Moon, HQUSACE, "Corps Steps Up Computer Aids for Engineers," Engineer Update, 11 (Oct. 1987); Fact Sheet, "Computer Graphics."

29. Col. John A. Poteat to Lt. Gen. Joseph K. Bratton, 16 July 1984, Periodic Letters, HND.

30. Lt. Gen. Joseph K. Bratton to Col. Rudolph E. Abbott, 10 Sept. 1984, Periodic Letters, HND.

31. Memorandum for the Commander, USACE, subject: "Command Visit, U.S. Army Engineer Division, Huntsville, 27-29 June 1984," from Brig. Gen. George K. Withers, Jr., HQUSACE, 2 Aug.

1984, Executive Office Files, HND.

32. Col. Rudolph E. Abbott to Lt. Gen. E.R. Heiberg, III, 25 Feb. 1985, Periodic Letters, HND.

33. Lt. Gen. E.R. Heiberg, III to Col. Rudolph E. Abbott, 6 May 1985, Periodic Letters, HND.

34. Fact Sheet, "Computer Graphics."

## CHAPTER 6

1. Briefing to the Chief of Engineers, Fort Belvoir, VA, 1 Oct. 1984, Historical Files, HND.

2. Lt. Gen. Joseph K. Bratton to Col. John A. Poteat, 29 Mar. 1984, Periodic Letters, HND.

3. Memorandum for the Commander, USACE, subject: "Final Report of U.S. Army Engineer Division, Huntsville, Command Inspection, 21-24 September 1987," from Brig. Gen. Peter J. Offringa, 12 Nov. 1987, Executive Office Files, HND.

4. Program Review and Analysis, HND, 4th quarter for each fiscal year from FY 1982 to FY 1987.

5. Ibid.

6. Brochure, "CE Training Management Division: Increased Productivity Through Quality Training," HNDTD, c. 1988, Training Management Division Files, HND.

7. Disposition Form, Mr. Emmett N. Creekmore, Chief, CE Training Management Division, HND, to Public Affairs Officer, HND, subject: "Division Historical Summary," 29 Mar. 1983, Historical Files, HND.

8. Quarterly Newsletter, HNDTD, Issue 83-3, Mar. 1983, Training Management Division Files, HND.

9. Information Bulletin, HND, Vol. 5, May 1983, Historical Files, HND; Col. Rudolph E. Abbott to Lt. Gen. E.R. Heiberg III, 21 Aug. 1985, Periodic Letters, HND; Quarterly Newsletter, HNDTD, Issue 86-1, Oct. 1985, Training Management Division Files, HND.

10. Col. John A. Poteat to Lt. Gen. Joseph K. Bratton, 21 Jan. 1982, Periodic Letters, HND; Col. John A. Poteat to Lt. Gen. Joseph K. Bratton, 19 May 1982, Periodic Letters, HND; Quarterly Newsletter, HNDTD, Issue 82-3, Mar. 1982, Training Management Division Files, HND.

11. "Significant Accomplishments During FY 84," Historical Files, HND.

12. Ibid.

13. Information bulletin, HND, Vol. V, No. 8, Aug. 1986, Historical Files, HND.

14. Memorandum for the Commander, USACE, subject: "Command Visit, U.S. Engineer Division, Huntsville, 16-18 March 1983," from Brig. Gen. C.E. Edgar III, 19 Apr. 1983, Executive Office Files, HND.

15. Memorandum for the Commander, USACE, subject: "Final Report of U.S. Army Engineer Division, Huntsville, Command Inspection, 21-24 September 1987," 12 Nov. 1987, Executive Office Files, HND.

16. Memorandum for the Commander, USACE, subject: "Command Inspection, U.S. Army Engineer Division, Huntsville, 6-7 April 1981," from Maj. Gen. Drake Wilson, Executive Office Files, HND; Command Briefing, Col. Lacey's Version, Revised 25 Oct. 1983, Historical Files, HND.

17. Program Fact Sheet, HND, Jan. 1983, Historical Files, HND.

18. Information Bulletin, HND, Vol. 5, May 1982, Historical Files, HND.

19. Disposition Form, Mr. Emmett N. Creekmore, Chief, HNDTD, subject: "Division Historical Summary," to Public Affairs Officer, HND, 29 Mar. 1983, Historical Files, HND.

20. Ibid.

21. Quarterly Newsletter, HNDTD, Issue 84-1, Sept. 1983, Training Management Division Files, HND.

22. Quarterly Newsletter, HNDTD, Issue 85-1, Sept. 1984, Training Management Division Files, HND.

23. Brochure, "CE Training Management Division: Increased Productivity Through Quality Training," prepared by the Training Management Division, HND, c. 1988, Training Management Division Files, HND.

24. Most of this section is developed from the following two sources: Letter, Mr. Emmett N. Creekmore, Chief, HNDTD, to author, 15 Aug. 1989, author's files, hereafter cited as Creekmore to author, and the Quarterly Newsletter, HNDTD, Training Notes, Issue 83-2, Dec. 1982, Training

Management Division Files, HND.

25. Creekmore to author.
26. Ibid.
27. Ibid.
28. Quarterly Newsletter, HNDDTD, Issue 82-3, Mar. 1982, Training Management Division Files, HND.
29. Ibid.
30. Anonymous, "Huntsville Produces Video

Mobilization Course," Engineer Update, Vol. 6, No. 12, Dec. 1982, Historical Files, HND.

31. The above data on mobilization courses was derived from a Brochure titled "CE Training Management Division: Increased Productivity Through Quality Training," HNDDTD, c. 1988, Training Management Division Files, HND.

32. Quarterly Newsletter, HNDDTD, Issue 85-1, Sept. 1984, Training Management Division Files, HND.

# Appendix

## List Of

### Huntsville Division Commanders

**Colonel John A. Poteat**

September 1980 -- 31 July 1984

**Colonel Rudolph E. "Jim" Abbott**

1 August -- 13 February 1987

**Colonel Robert S. Lindsay (Acting)**

14 February -- 14 July 1987

**Colonel Charles T. Myers III**

15 July 1987 --

## Gallery of

### Distinguished Civilian Employees

**Emil Vuch**

Division Counsel

1987

**Walter R. Peterson**

Chief, Engineering Division

1987

**William L. Little**

Chief, Engineering Division

1987

**Thor S. Anderson**

Chief, Contracting Division

1987

**Lee S. Garrett**

Chief Engineering Division

1987

# Bibliography

## Records

Huntsville, Alabama. Corps of Engineers. Huntsville Division. Historical Files. These files contain the bulk of sources from which the history of the period is written.

Huntsville, Alabama. Corps of Engineers. Huntsville Division. Executive Office Files. These very informative records contain the HQUSACE inspection reports and Periodic Letters written by Huntsville Division commanders to the Chief of Engineers and by the Chief of Engineers to Huntsville Division commanders.

Huntsville, Alabama. Corps of Engineers. Huntsville Division. Resource Management Office. Active Files.

Huntsville, Alabama. Corps of Engineers. Huntsville Division. Training Management Division. Active Files.

## Secondary Works

Anonymous. "Corps Starts Star Wars Work," *Engineering News-Record*, 217 (11 Dec. 1986): 16.

Anonymous. "Building Bit by Bit," *Military Review*, 62 (Sept. 1982): 71.

Anonymous. "Huntsville Produces Video Mobilization Course," *Engineer Update*, 6 (Dec. 1982).

Mallett, Nita. "Fort Worth, Huntsville to Put Up Laser Facility," *Engineer Update*, 11 (Sept. 1987).

Moon, Terri. "Corps Steps Up Computer Aids for Engineers," *Engineer Update*, 11 (Oct. 1987).

Heidish, Louise Schwallie. *A History of the Huntsville Division, U.S. Army Corps of Engineers, 1977-1981 Update*. Huntsville, AL.: Huntsville

Division, Corps of Engineers, 1983.

## Interviews

Abbott, Col. (Ret.) Rudolph E. Interviewed by the author. Los Angeles, CA. 8 June 1988.

Aldridge, Raymond D. Interviewed by the author. Huntsville, AL. 9 June 1988.

Creekmore, Emmett N. Interviewed by the author. Huntsville, AL. 13 June 1988.

Dupree, Gerald D. Interviewed by the author. Huntsville, AL. 15 June 1988.

Henderson, Al. Interviewed by the author. Huntsville, AL. 7 June 1988.

Liebes, Gerald. Interviewed by the author. Washington, DC. 7 July 1988.

Lindsay, Col. (Ret.) Robert S. Interviewed by the author. Huntsville, AL. 6 June 1988.

Loschialpo, Ralph. Interviewed by the author. Washington, DC. 8 July 1988.

McIlrath, Lt. Col. John C. Interviewed by the author. Huntsville, AL. 14 June 1988.

Miller, Col. William A. Interviewed by the author. Huntsville, AL. 3 June 1988.

Peterson, Walter R. Interviewed by the author. Huntsville, AL. 3 June 1988.

Potat, Col. (Ret.) John A. Interviewed by the author. Huntsville, AL. 5 June 1988.

Vincent, Jim. Interviewed by the author. Washington, DC. 8 July 1988.

## Author's Correspondence

Creekmore, Emmett N. to author. 15 August 1989, author's files. Littleton, CO.

