

"CONTINUOUS OPERATION OF A 250 KW THYRATRON"*

Henry C. Grunwald
ITT Electron Technology Division
Easton, PA
Joseph McGowan
Electronics Technology & Devices Laboratory
Ft. Monmouth, NJ
John E. Creedon**

Abstract

ITT ETD has designed, fabricated and delivered three (3) high power thyratrons, Type F259, in which the use of a dispenser cathode is a major design improvement. By substituting the dispenser cathode in lieu of a conventional oxide coated structure, ITT is attempting to develop a device of extremely high average current capability (500 amperes is the Phase III objective). Present state of the art is eight (8) amperes. Two (2) of the F259's have been tested by ETDL using its high power modulator facilities. Both of these tubes have demonstrated the feasibility of operating above the Phase I objective of 18 amperes. Continuous operation for several hours at an average current of 20 amperes and at a repetition rate of 1000 hertz has been achieved. A third tube was delivered to Lawrence Livermore Laboratory where it is currently being evaluated in the Free Electron Laser modulator. Testing is continuing to establish the ultimate peak current capability and barium depletion characteristics on life.

Introduction

Multi-megawatt average power thyratron performance is a key technology issue for successful Strategic Defense Initiative (SDI) advanced systems operation. The initial phase of a multi-year development program has been directed toward the establishment of an understanding of the physical limitations and capabilities of super power thyratrons. Additionally, near-term fabrication of prototype devices was initiated. Work included the extension of known technology to theoretical maximums by scaling techniques and novel approaches utilizing vast departures from classical design methods. Development models were manufactured, electrically conditioned at the ITT ETD Easton facility and delivered to ETDL, Pulse Power Laboratory, Ft. Monmouth, NJ, LANL, Los Alamos, NM and the Experimental Test Accelerator, LLNL, Livermore, CA for operational and system conformance testing. The major program milestone achieved, in the first phase of this task, was the successful design, construction and test of a dispenser cathode thyratron with continuous operation capability of in excess of 20 amperes average, at pulse repetition rates to 1000 hertz.

Objective specifications and demonstrated performance levels for Phase I of the project are shown in Table 1:

Table 1

Phase I Thyratron Objectives and Performance Achieved

<u>Parameters</u>	<u>Objective</u>	<u>Performance Demonstrated</u>
Peak Anode Voltage (epy)	25,000	50,000 volts
Peak Anode Current (ib)	12,500	16,000 amperes
Pulse Width (tp)	5	5-10 microsec.
Pulse Repetition Rate (pr)	10-100	100-1000 hertz
Average Current (Ib)	18	21 amperes dc

Technical Approach

Due to the short period of performance allowed for Phase I, simultaneous evaluation of key objectives, namely cathode, grid and envelope structure design, was performed on common prototype thyratrons. These prototypes were shipped to the Pulse Power Laboratory, Ft. Monmouth, NJ for test and evaluation, after preliminary test at the ITT ETD Easton, PA, facility. Evaluation objectives were dictated by the circuit constants of the Ft. Monmouth Pulse Power Test facility and were directed toward potential SDIO system applications. Tests were designed and performed to extract the maximum data, without destroying the device under test. Long-term testing, to further characterize the tubes and to verify life capability, is continuing and is currently in process at ETDL, Ft. Monmouth, NJ and LLNL, Livermore, CA. The major milestone achievement to date is operation at an average current of 20 amperes for in excess of 36 million pulses at pulse repetition rates of up to one (1) kilohertz for extended periods (exceeding five (5) hours) without fault, prefire or inverse clipping. The tubes are still completely operational and further evaluation is continuing at increasingly elevated power levels. The maximum operating capability of the ITT ETD prototype F259 thyratron has not yet been established, notwithstanding the Phase I objectives have been demonstrated.

Report Documentation Page

Form Approved
OMB No. 0704-0188

Public reporting burden for the collection of information is estimated to average 1 hour per response, including the time for reviewing instructions, searching existing data sources, gathering and maintaining the data needed, and completing and reviewing the collection of information. Send comments regarding this burden estimate or any other aspect of this collection of information, including suggestions for reducing this burden, to Washington Headquarters Services, Directorate for Information Operations and Reports, 1215 Jefferson Davis Highway, Suite 1204, Arlington VA 22202-4302. Respondents should be aware that notwithstanding any other provision of law, no person shall be subject to a penalty for failing to comply with a collection of information if it does not display a currently valid OMB control number.

1. REPORT DATE JUN 1987	2. REPORT TYPE N/A	3. DATES COVERED -	
4. TITLE AND SUBTITLE Continuous Operation Of A 250 Kw Thyatron		5a. CONTRACT NUMBER	
		5b. GRANT NUMBER	
		5c. PROGRAM ELEMENT NUMBER	
6. AUTHOR(S)		5d. PROJECT NUMBER	
		5e. TASK NUMBER	
		5f. WORK UNIT NUMBER	
7. PERFORMING ORGANIZATION NAME(S) AND ADDRESS(ES) ITT Electron Technology Division Easton, PA		8. PERFORMING ORGANIZATION REPORT NUMBER	
9. SPONSORING/MONITORING AGENCY NAME(S) AND ADDRESS(ES)		10. SPONSOR/MONITOR'S ACRONYM(S)	
		11. SPONSOR/MONITOR'S REPORT NUMBER(S)	
12. DISTRIBUTION/AVAILABILITY STATEMENT Approved for public release, distribution unlimited			
13. SUPPLEMENTARY NOTES See also ADM002371. 2013 IEEE Pulsed Power Conference, Digest of Technical Papers 1976-2013, and Abstracts of the 2013 IEEE International Conference on Plasma Science. Held in San Francisco, CA on 16-21 June 2013. U.S. Government or Federal Purpose Rights License			
14. ABSTRACT ITT ETD has designed, fabricated and delivered three (3) high power thyratrons, Type F259, in which the use of a dispenser cathode is a major design improvement. By substituting the dispenser cathode in lieu of a conventional oxide coated structure, ITT is attempting to develop a device of extremely high average current capability (500 amperes is the Phase III objective). Present state of the art is eight (8) amperes. Two (2) of the F259' s have been tested by ETDL using it's high power modulator facilities. Both of these tubes have demonstrated the feasibility of operating above the Phase I objective of 18 amperes. Continuous operation for several hours at an average current of 20 amperes and at a repetition rate of 1000 hertz has been achieved. A third tube was delivered to Lawrence Livermore Laboratory where it is currently being evaluated in the Free Electron Laser modulator. Testing is continuing to establish the ultimate peak current capability and barium depletion characteristics on life.			
15. SUBJECT TERMS			
16. SECURITY CLASSIFICATION OF:			17. LIMITATION OF ABSTRACT SAR
a. REPORT unclassified	b. ABSTRACT unclassified	c. THIS PAGE unclassified	
			18. NUMBER OF PAGES 4
			19a. NAME OF RESPONSIBLE PERSON

Tube Construction Features

Construction of the developmental F259 thyratron included the following features:

- o Porous tungsten, dispenser cathode
- o Non-symmetrical, two (2) gap gradient grid structure
- o External metal cylinder control grid structure
- o Refractory metal and copper laminated grid partition; brazed construction
- o Shunt-path molecular hydrogen replenishment

A cross-sectional view of the prototype device incorporating all of the foregoing construction features is shown in Figure 1. A photograph of the external structure of the F259 is shown in Figure 2.

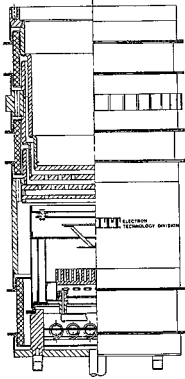

FIGURE 1
F259 CROSS-SECTION

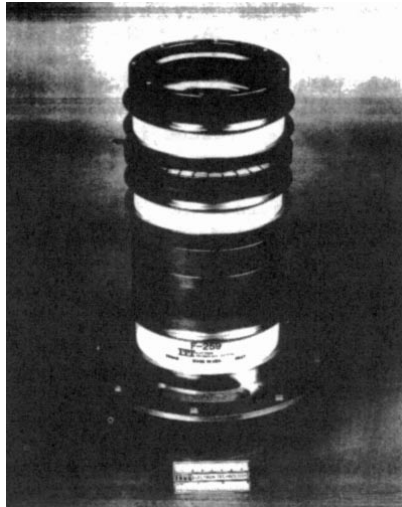

FIGURE 2
F259 EXTERNAL CONSTRUCTION

Cathode Design

The cathode consists of a massive 0.682 kg. 7.62 cm diameter, 82% density porous tungsten block structure, impregnated with a mole ratio of 4BaO:1CaO:1 Al₂O₃. The blocks were machined into two alternate geometric configurations:

- 1) circular concentric vanes of 285 cm² and
- 2) straight vanes of 270 cm² total emitting surface area.

Vane height was defined as 1.27 cm and vane spacing at 2.54 mm, based upon an aspect ratio of 5:1, a prerequisite for a secondary electron emission factor greater than unity between the vane side surfaces. The cathode is heated to 1050°C operating temperature by a 500 watt "potato - masher" tungsten heater, located within the cathode heat choke (molybdenum rhenium) cylinder. No distinct advantage between the two (2) alternate vane configurations has been determined to date. A photograph of this cathode/reservoir construction is shown in Figure 3.

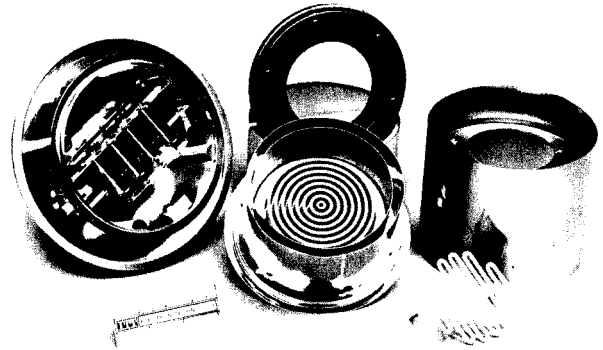

FIGURE 3
F259 CATHODE/RESERVOIR SUB-ASSEMBLIES

Non-Symmetrical Gradient Grid Design

Classically, care is taken to insure equal interelectrode capacitance for the gaps of gradient grid tubes. In the nested cup configuration, this approach "buries" the control grid (a highly dissipative electrode) deep within the tube, thermally insulating it from the external cooling media at the ceramic envelope walls. The F259 discards the above approach and provides maximum thermal conductivity from grid apertures to external sink by locating the control grid on an external copper cylinder of large 486 cm² heat transfer surface area. A comparison of the control grid external heat transfer surfaces of the benchmark, conventional F241 design and the developmental F259 device is illustrated in Figure 4. The F259 electrode and body ceramic subassemblies are shown in the photograph of Figure 5.



FIGURE 4
F259 VS F241 GRID STRUCTURE COMPARISON

Anular apertures of 3.5 mm width were utilized in both grid and baffle plates, yielding an effective opening area of 21 cm² in the control grid and 18.0 cm² in the gradient grid and control grid baffle. This equates to long pulse, peak current capability of 29 ka and 25 ka respectively, using the empirically determined 1.4 ka/cm² maximum aperture current density value.

Aperture locations and overlap were calculated to preclude line of sight anode field penetration. Designs were verified by computer plot of equipotential voltage lines within the tube structure. The data was obtained from the solution of the Laplace Equation in the ITT ETD Electron Trajectory Program (based upon the Herrmannsfeldt SLAC gun code) for the given geometry.

A typical equipotential field plot used in voltage field penetration analysis is shown in Figure 7.



FIGURE 5
F259 ELECTRODE ASSEMBLIES

Grid Material and Aperture Design

Thermal conductivity of grid members plays a major role in super power thyratron operation. Surface thermal integrity, or freedom from localized heating and subsequent metal vapor arcs, may be achieved by the utilization of among others, three (3) construction techniques:

- 1) Molybdenum Partitions
- 2) Tungsten Carbide, Flame Spray Coated Copper
- 3) Molybdenum-Copper-Molybdenum Laminate

Of the three (3), the composite grid partition shown in Figure 6 has proven the most reliable, to date. The high surface melting temperature of molybdenum (2610°C) is complemented by the high thermal conductivity (3.91 watt/cm °C) of the copper core.

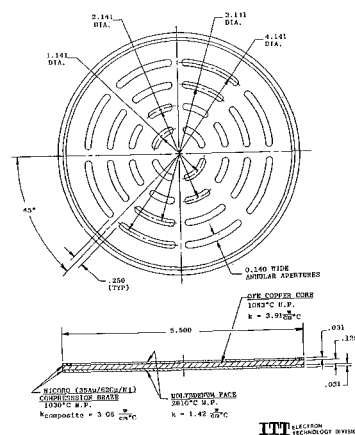

FIGURE 6
MOLYBDENUM/COPPER LAMINATE GRID

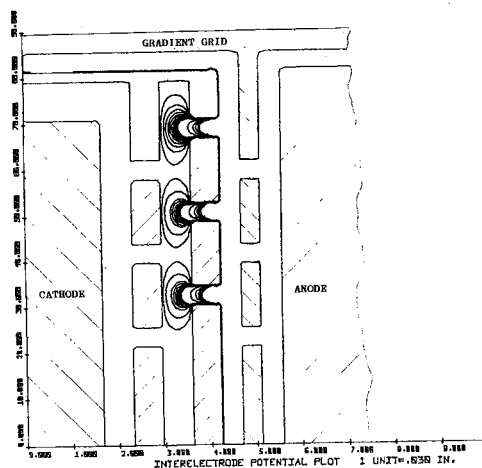

FIGURE 7
EQUIPOTENTIAL FIELD LINE PLOT

Gas Cooling By Molecular Hydrogen Circulation

A shunt gas path was included in the construction by machining 5 mm holes in the electrode rings, in parallel to the main discharge path. The shunt gas path benefits were twofold and dramatic:

- 1) Replenishment of molecular neutral gas to enhance internal heat transfer.
(NOTE: Principal cooling of internal tube components is accomplished by thermal conduction through the gas.)
- 2) Provision for a source of electrons to replace those "pumped" from the gap regions, thereby tending to equilibrate gas density throughout the entire tube.

The aggregate hole was calculated to equal the annular cross-sectional area of electrode O.D. to ceramic cylinder I.D. space, thus providing a constant path cross-section for neutral gas flow around the main discharge path.

Reservoir and Gas Fill

Four (4) large titanium hydride reservoirs were utilized to maintain a 500 micron pressure of hydrogen gas within the thyatron. Temperature/pressure equilibrium was accomplished with 40 watts maximum, of reservoir heater power. Particular attention was directed to thermally decoupling the reservoir from the cathode. Potential parasitic heating of the reservoir at the required super power rms cathode currents, due to the associated cathode ohmic losses, could destabilize the optimum reservoir basepoint if thermal shielding were not carefully considered.

Thyatron Test Data

Electrical conditioning and preliminary test, at the ITT Electron Technology, Easton, PA facility, was performed in a 600 KW, 30 KV DC, line-type modulator, fitted with a 4.0 ohm, 7.5 microsecond Pulse Forming Network (PFN), with matched resistive load. No inverse clipper circuitry was utilized. Tubes were operated continuously in air with forced cooling at up to peak forward voltages of 54 kv and at average currents up to 7 amperes prior to shipment to the Ft. Monmouth Pulse Power Test Facility.

The initial Ft. Monmouth Test Facility consisted of a 3.3 megawatt, 22 kv dc power supply and a 10 microsecond PFN having a 3.5 ohm impedance. An air-cooled Ohmweave load was used that gave a small positive mismatch. No inverse clipper circuitry was utilized. The tube under test (TUT) was immersed in non-circulating transformer oil.

ITT ETD type F241 thyatron, shown in Figure 4, was selected for initial technology benchmark device capability testing. Reliable operation was recorded at:

epy = 26 kv, ib = 6,500 a, PRF = 184 pps, Ib = 12 Adc.

Internal thermal device limitations became evident after fifteen (15) minutes of operation at:

epy = 32 kv, ib = 8,000 a, PRF = 184 pps, Ib = 14.8 Adc

On the basis of the benchmark evaluation, it was concluded that the all copper grid structure of the F-241 was capable of 12.5 Adc, continuous operation, oil immersed.

The ITT ETD type F259 prototype thyatron shown in the photograph of Figure 2 and in outline in Figure 1 was then installed and evaluated with the 3.5 ohm network. The device was operated for greater than 3.6×10^7 pulses (to date) at various repetition rates (400, 500, 940, 1000 pps) at anode voltages of 18 to 30 kv for continuous operating periods to five (5) hours at 20 to 21 Adc, without fault (high voltage overload), prefire or clipping. Tube performance was steady and showed no sign of degrading. Thyatron thermal management design was verified by the stabilization of anode operating temperature at 100°F after 60 minutes of 20 Adc operation. It should be noted that although the 20 Adc average current level and the 1,000 pps pulse repetition rate EXCEEDED the project objective goal levels, they represent the maximum current LEVEL OF TESTING---not ultimate device capability. Continued testing and final characterization of the Phase I design will be incorporated into the goals and objectives of the follow-on phase of this research program.

*A portion of the support for this work was provided by the Department of Energy, Los Alamos National Laboratory, NM and partially funded by ETDL and ITT ETD.

**Mr. Creedon is a consultant with SRI, International.

Acknowledgements

The authors wish to acknowledge the significant contribution to device mechanical design by Charles L. Shackelford, ITT ETD.