

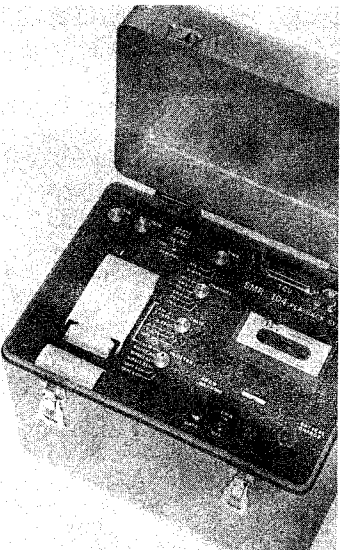

US Army Corps
of Engineers



630.202
R28
CS-5
REMR
CS-5

US ARMY CORPS OF ENGINEERS
**REPAIR, EVALUATION, MAINTENANCE, AND
REHABILITATION RESEARCH PROGRAM**

TECHNICAL REPORT REMP-CS-5

INSTRUMENTATION AUTOMATION FOR CONCRETE STRUCTURES

Report 1

INSTRUMENTATION AUTOMATION TECHNIQUES

by

John Lindsey, David Edwards, Aubrey Keeter,
Tom Payne, Roger Malloy

WYLE Laboratories
3200 Magruder Blvd.
Hampton, Virginia 23666-1498

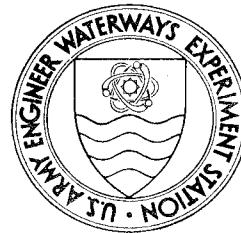

December 1986

Report 1 of a Series

Approved For Public Release; Distribution Unlimited

Prepared for DEPARTMENT OF THE ARMY
US Army Corps of Engineers
Washington, DC 20314-1000

Under Contract No. DACW39-85-C-0051
(Civil Works Research Work Unit 32309)

Monitored by Structures Laboratory
US Army Engineer Waterways Experiment Station
PO Box 631, Vicksburg, Mississippi 39180-0631

The following two letters used as part of the number designating technical reports of research published under the Repair, Evaluation, Maintenance, and Rehabilitation (REMR) Research Program identify the problem area under which the report was prepared:

| | <u>Problem Area</u> | | <u>Problem Area</u> |
|----|-------------------------------|----|---------------------------|
| CS | Concrete and Steel Structures | EM | Electrical and Mechanical |
| GT | Geotechnical | EI | Environmental Impacts |
| HT | Hydraulics | OM | Operations Management |
| CO | Coastal | | |

For example, Technical Report REMR-CS-1 is the first report published under the Concrete and Steel Structures problem area.

Destroy this report when no longer needed. Do not return it to the originator.

The findings in this report are not to be construed as an official Department of the Army position unless so designated by other authorized documents.

The contents of this report are not to be used for advertising, publication, or promotional purposes. Citation of trade names does not constitute an official endorsement or approval of the use of such commercial products.

COVER PHOTOS:

TOP -- Typical cutout at a plumbline location where an automated monitoring system has been installed. The sensor used with the automated system is hidden from view, except for the bottom, since it is installed up in the plumbline well.

BOTTOM -- An SMR-104 portable playback/plotter used in field testing, calibration, and playback of DCA/DCS seismic data acquisition systems.

Unclassified
SECURITY CLASSIFICATION OF THIS PAGE

CLASSIFIED

| REPORT DOCUMENTATION PAGE | | | | Form Approved OMB No 0704-0188 Exp. Date Jun 30, 1986 | |
|--|-------|---|---|---|----------------------------------|
| 1a. REPORT SECURITY CLASSIFICATION Unclassified | | 1b. RESTRICTIVE MARKINGS | | | |
| 2a. SECURITY CLASSIFICATION AUTHORITY | | 3. DISTRIBUTION/AVAILABILITY OF REPORT Available for public release; distribution unlimited. | | | |
| 2b. DECLASSIFICATION/DOWNGRADING SCHEDULE | | 4. PERFORMING ORGANIZATION REPORT NUMBER(S) | | | |
| 4. PERFORMING ORGANIZATION REPORT NUMBER(S) | | 5. MONITORING ORGANIZATION REPORT NUMBER(S) Technical Report REMR-CS-5, Report 1 | | | |
| 6a. NAME OF PERFORMING ORGANIZATION WYLE Laboratories | | 6b. OFFICE SYMBOL (if applicable) | 7a. NAME OF MONITORING ORGANIZATION Structures Laboratory US Army Engineer Waterways Experiment Station | | |
| 6c. ADDRESS (City, State, and ZIP Code) 3200 Magruder Blvd. Hampton, VA 23666-1498 | | 7b. ADDRESS (City, State, and ZIP Code) PO Box 631 Vicksburg, MS 39180-0631 | | | |
| 8a. NAME OF FUNDING/SPONSORING ORGANIZATION US Army Corps of Engineers | | 8b. OFFICE SYMBOL (if applicable) | 9. PROCUREMENT INSTRUMENT IDENTIFICATION NUMBER | | |
| 8c. ADDRESS (City, State, and ZIP Code) 20 Massachusetts Avenue, NW Washington, DC 20314-1000 | | 10. SOURCE OF FUNDING NUMBERS | | | |
| | | PROGRAM ELEMENT NO. | PROJECT NO. | TASK NO. | WORK UNIT ACCESSION NO. 32309 |
| 11. TITLE (Include Security Classification) Instrumentation Automation for Concrete Structures; Instrumentation Automation Techniques | | | | | |
| 12. PERSONAL AUTHOR(S) John Lindsey, David Edwards, Aubrey Keeter, Tom Payne, Roger Malloy | | | | | |
| 13a. TYPE OF REPORT Report 1 of a series | | 13b. TIME COVERED FROM _____ TO _____ | 14. DATE OF REPORT (Year, Month, Day) December 1986 | | 15. PAGE COUNT 195 |
| 16. SUPPLEMENTARY NOTATION A report of the Concrete and Steel Structures problem area of the Repair, Evaluation, Maintenance, and Rehabilitation (REMR) Research Program. Available from National Technical Information Service, 5285 Port Royal Road, Springfield, VA 22161. | | | | | |
| 17. COSATI CODES | | 18. SUBJECT TERMS (Continue on reverse if necessary and identify by block number) | | | |
| FIELD | GROUP | SUB-GROUP | Concrete construction--Instruments--Automation (LC) | | |
| | | | Automatic data collection systems (LC) | | |
| | | | Hydraulic structures--Instruments--Automation (LC) (over) | | |
| 19. ABSTRACT (Continue on reverse if necessary and identify by block number) | | | | | |
| <p>This report is a guide to determining the requirements for and the subsequent design, assembly or fabrication, installation, checkout, operation, and maintenance of data acquisition and reduction systems for use at or in large concrete hydraulic structures. It is a companion to two other reports in the series: Report 2, "Automation Hardware and Retrofitting Techniques," and Report 3, "Available Data Collection and Reduction Hardware." The report describes automation techniques and requirements for maintaining automated instrumentation in a generic fashion. It focuses on system concepts and describes the steps necessary for implementing automated instrumentation monitoring systems suitable for use in or at large concrete hydraulic structures.</p> | | | | | |
| 20. DISTRIBUTION/AVAILABILITY OF ABSTRACT <input checked="" type="checkbox"/> UNCLASSIFIED/UNLIMITED <input type="checkbox"/> SAME AS RPT <input type="checkbox"/> DTIC USERS | | | 21. ABSTRACT SECURITY CLASSIFICATION Unclassified | | |
| 22a. NAME OF RESPONSIBLE INDIVIDUAL Edward F. O'Neill | | 22b. TELEPHONE (Include Area Code) 601-634-3268 | | 22c. OFFICE SYMBOL WESSU-CE | |

Unclassified

SECURITY CLASSIFICATION OF THIS PAGE

18. SUBJECT TERMS (Continued).

Hydraulic engineering--Instruments--Automation (IC)
Automatic control (LC)

Unclassified

SECURITY CLASSIFICATION OF THIS PAGE

PREFACE

This is Report 1 of a series entitled "Instrumentation Automation for Concrete Structures." The report describes how to determine the requirements for and the subsequent design, assembly or fabrication, installation, checkout, operation, and maintenance of data acquisition and data reduction systems for use at or in large concrete hydraulic structures. Report 2, "Automation Hardware and Retrofitting Techniques," is a guide to commercially available instruments and equipment which will automate measurements of structural behavior and environmental conditions at large concrete structures, along with the suggested methods to replace or retrofit existing instruments at US Army Corps of Engineers structures. Available software packages for data acquisition and reduction instruments are described in Report 3, "Available Data Collection and Reduction Software."

The information in this report was compiled by Wyle Laboratories under contract to the US Army Engineer Waterways Experiment Station (WES). A panel of electrical and electronic engineers of Wyle Laboratories' Scientific Services and Systems Group authored the report. The contract was monitored by the Concrete Technology Division (CTD) of the Structures Laboratory (SL), WES. Wyle was ably assisted and advised by the Contracting Officer's Representative, Mr. Edward F. O'Neil, Evaluation and Monitoring Unit, CTD, regarding the various technical aspects in report preparation. Project manager for Wyle Laboratories was Mr. Aubrey C. Keeter.

Publication of the report was funded under Civil Works Research Work Unit 32309, "Improved Instrumentation for Older Structures," for which Mr. O'Neil is principal investigator. This work unit is part of the Concrete and Steel Structures Problem Area of the Repair, Evaluation, Maintenance, and Rehabilitation (REMR) Research Program sponsored by Headquarters, US Army Corps of Engineers (HQUSACE). The Overview Committee of HQUSACE for the REMR Research Program consists of Mr. James E. Crews (Chairman), Mr. Bruce L. McCartney, and Dr. Tony C. Liu. Technical Monitor for this study was Dr. Liu.

The investigation was performed under the general supervision of Mr. Bryant Mather, Chief, SL, and Mr. John M. Scanlon, Chief, CTD, and under the direct supervision of Mr. Henry T. Thornton, Jr., Chief, Evaluation and Monitoring Unit, CTD. Problem Area Leader for Concrete and Steel Structures is Mr. James E. McDonald, CTD. Program Manager for REMR is Mr. William F. McCleese, CTD.

COL Dwayne G. Lee, CE, was Commander and Director of WES during the publication of this report. Dr. Robert W. Whalin was Technical Director.

CONTENTS

| | Page |
|---|------|
| PREFACE | 1 |
| PART I: INTRODUCTION | 7 |
| PART II: SYSTEM REQUIREMENTS DOCUMENT | 11 |
| Functional Requirements | 12 |
| Physical Phenomena to be Measured | 12 |
| Resolution and Accuracy | 12 |
| Reliability, Criticality Requirement | 14 |
| Sample Rate and Frequency of Interest | 15 |
| Signal Distribution and Acquisition | 16 |
| Computation Requirements | 18 |
| Alarm, Display, and/or Recording Equipment ... | 19 |
| Power Requirements/Availability | 19 |
| Power Backup and Conditioning Requirements ... | 20 |
| Environmental Requirements | 21 |
| Natural Environment | 21 |
| Induced Environment | 22 |
| Sample Form of System Requirements Document | 23 |
| PART III: SYSTEM DESIGN | 37 |
| System Considerations | 37 |
| Automated Measurement Techniques | 38 |
| Component Compatibility | 40 |
| Instrument/System Characteristics | 40 |
| Interfacing Techniques | 41 |
| Power Sources | 43 |
| Grounding Techniques | 44 |
| Maintainability | 45 |
| Operability | 46 |
| System Calibration | 46 |
| System Flexibility | 48 |
| Economic Factors | 49 |
| Sensors/Detectors/Transducers | 50 |
| Special LVDT Characteristics..... | 57 |
| Transducer Selection Criteria | 63 |
| Transducer Hazards | 65 |
| Signal Conditioning | 68 |
| Bridge Circuits | 69 |
| Amplification | 71 |
| Instrumentation Amplifiers | 71 |
| Isolation Amplifiers | 74 |
| Filtering | 76 |

CONTENTS (Continued)

| | Page |
|--|------|
| Signal Conversion | 78 |
| Electrical Interferences | 81 |
| Data Transmission | 84 |
| Multiplexing | 85 |
| System Configurations..... | 86 |
| Transmission Techniques | 90 |
| Data Transmission Interval | 92 |
| Transfer Rate (Resolution and Accuracy) | 93 |
| Data Bandwidth | 93 |
| Data Processing, Display, and Recording | 94 |
| Data Processing | 94 |
| Data Manipulation | 96 |
| Display | 96 |
| Recording/Storage | 97 |
| PART IV: SYSTEM DESIGN DOCUMENT AND DESIGN REVIEW | 99 |
| Guidelines for Preparation of a System | |
| Design Document | 99 |
| Guidelines for Conducting a Design Review | 100 |
| PART V: SYSTEM IMPLEMENTATION | 103 |
| Detailed Design | 103 |
| Procurement and Receiving Inspection | 104 |
| Procurement | 105 |
| Receiving Inspection..... | 106 |
| Acceptance Tests | 107 |
| Metrology Controls | 108 |
| System Fabrication | 108 |
| System Integration | 109 |
| System Installation | 111 |
| Documentation | 114 |
| PART VI: MAINTENANCE | 117 |
| Maintenance Philosophy | 117 |
| Types of Maintenance | 117 |
| Level of Repair | 118 |
| Preventive Maintenance | 119 |
| Calibration | 120 |
| Documentation | 122 |
| Maintenance Software (diagnostic) | 126 |
| Spare Parts | 127 |

CONTENTS (Continued)

| | Page |
|------------------------------|------|
| Test Equipment | 129 |
| Training | 129 |
| GLOSSARY..... | 135 |
| REFERENCES | 173 |
| SUGGESTED READING LIST | 175 |

LIST OF FIGURES

No.

| | |
|--|----|
| 1. Typical Automated Instrumentation/Data Acquisition System..... | 14 |
| 2. Wheatstone Bridge Circuit..... | 56 |
| 3. Thermocouple Electrical Reference Junction..... | 61 |
| 4. The RTD in Application..... | 63 |
| 5. Transducer Excitation Polarity Protection..... | 66 |
| 6. Bridge with Sensitivity, Balance, and Calibration Features..... | 69 |
| 7. Transducer-Amplifier Interconnection..... | 76 |
| 8. Typical Digital-to-Analog Network..... | 80 |
| 9. A Single Amplifier to Reject Signal E..... | 82 |
| 10. Excitation Voltage as a Common-Mode Signal..... | 82 |
| 11. Typical Multiplexed Link..... | 85 |
| 12. Star Configuration..... | 87 |
| 13. Loop Configuration..... | 88 |
| 14. Distributed Configuration..... | 89 |

CONTENTS (Continued)

LIST OF FIGURES (Cont.)

No.

| | | |
|-----|--|----|
| B1. | Strain Gage Compensation..... | B2 |
| B2. | Strain Gage Transducer with Bridge Voltage Sensing Capability..... | B3 |
| B3. | Strain Gage Transducer with Remote "Shunt Calibration" Capability..... | B3 |
| B4. | Various Two-Active Arm Bridge Configurations.... | B4 |
| B5. | A Separate Signal Sense Line..... | B6 |

LIST OF TABLES

| | | |
|-------------|--|-----|
| 1. | Physical Measurement Parameters..... | 52 |
| 2. | ANSI Symbol and its Thermocouple Alloys..... | 59 |
| 3. | Industrial Worldwide Standards of RTDs..... | 62 |
| 4. | Transducer Selection Criteria..... | 64 |
| 5. | Maintenance Test Equipment Distribution..... | 130 |
| B1. | Output Signal per Unit of Bridge Excitation Plus Second-Order Error Terms for Various Bridge Configurations..... | B5 |
| APPENDIX A: | SYSTEM REQUIREMENTS DOCUMENT..... | A1 |
| APPENDIX B: | WHEATSTONE BRIDGE DESCRIPTIONS..... | B1 |

CONVERSION FACTORS, NON-SI TO SI (METRIC)

UNITS OF MEASUREMENT

Non-SI units of measurement used in this report can be converted to SI (metric) units as follows:

| <u>Multiply</u> | <u>By</u> | <u>To Obtain</u> |
|-----------------------------------|------------|--------------------------------|
| cubic feet | 0.02831685 | cubic metres |
| cubic inches | 0.00001639 | cubic metres |
| Fahrenheit degrees | 5/9 | Celsius degrees of kelvins* |
| feet | 0.3048 | metres |
| inches | 0.0254 | metres |
| inches per second | 0.0254 | metres per second |
| pounds (force) per square inch | 6.894757 | kilopascals |

* To obtain Celsius (C) temperature readings from Fahrenheit (F) readings, use the following formula: $C = (5/9)(F - 32)$. To obtain kelvin (K) readings, use: $K = (5/9)(F - 32) + 273.15$.

INSTRUMENTATION AUTOMATION TECHNIQUES

PART I: INTRODUCTION

1. This report is the first of a series of three reports entitled, "Instrumentation Automation for Concrete Structures", and issued by the U.S. Army Corps of Engineers. Instrumentation Automation for Concrete Structures is intended to be used as a guide by individuals and organizations in the Corps of Engineers who are engaged in design, configuration, implementation, and retrofitting of automated data collection systems for concrete structures. It is equally appropriate to apply the techniques discussed here to instrumentation for earth embankment dam projects. The three reports are:

Report 1 - Instrumentation Automation Techniques

This report provides a guideline for establishing the requirements for automating the data acquisition instrumentation associated with concrete structures. The report generically describes the procedures and methods required to design, install, and maintain fully automated data acquisition and reduction systems. The methods and equipment referenced in this report are described in detail in Report 2.

Report 2 - Automation Hardware and Retrofitting Techniques

This report provides a description of commercially available sensors, instruments, and ADP equipment that may be selected to fully automate measurements of structural behavior and environmental conditions. Methods to retrofit or replace instruments that are already installed at Corps of Engineers (COE) structures are included in this report. Due to the many options which exist in selecting the appropriate hardware, the procedures in Report 1 for determining system requirements should

be closely followed. Also, available software listed in Report 3 will influence system selection.

Report 3 - Available Data Collection and Reduction Software

This report serves as a guide in selecting software for equipment that is described in Report 2 and identifies commercially available software packages that are applicable to data acquisition and reduction instruments which may be used by the Corps of Engineers.

2. The Report on Automation Techniques presented herein describes automation techniques and requirements for maintaining automated instrumentation in a generic fashion. Increasingly, labor intensive operations are utilizing automated data acquisition systems which employ computers as the control and data manipulation device to improve efficiencies and cost-effectiveness. This report provides a review of technological developments and the adaptation of computers into instrumentation and control functions without making specific reference to any hardware or software manufacturers. It focuses on system concepts and describes the steps necessary for implementing automated instrumentation monitoring systems suitable for use in or at large concrete structures. The system designer is provided a path to follow which begins at the parameters to be measured and walks through the sensor selection, data transmission, data conversion, data manipulation, data display, and data storage. Practical approaches are presented along the way to resolve measurement problems and to provide a means of tailoring the system to meet specific requirements.

3. Part II of this report discusses the definition of system requirements and includes a sample "Systems Requirements Document" to serve as a guideline in specifying the system's functional requirements. The "Systems Requirements Document" catalogs the system functions, and also has space for specific requirements, i.e., physical phenomena to be monitored,

resolution and accuracy requirements, sample rate and frequency of data, computations to be performed, type of alarms, type of data displays, recording/storage equipment, power requirements and availability, and natural and induced environmental factors. In the final analysis, system configuration options should be based on the structure being instrumented, historical data measurement experience, state-of-the-art technology, and the Corps of Engineers' instrumentation criteria. Information regarding non-generic instrumentation specifications and availability is furnished in the "Report on Automation Hardware and Retrofitting Techniques."

4. PART III of this report discusses key factors that must be considered as the system is developed. The logical order of development is presented which includes: system considerations in determining measurement techniques; component compatibility; system characteristics; interfacing techniques; power sources; grounding techniques; maintainability; operability; system calibration; system flexibility; sensor selection criteria; transducer hazards; signal conditioning techniques; data transfer; data processing; data display; and recording and storage techniques.

5. Guidelines, which aid the designer in entering system design parameters into the master system design document, are furnished. Once the system design document is complete, the system is specified by manufacturer, model number, accuracy, speed, cost, etc. Similarly, guidelines for performing a design review are also furnished. The design review process utilizes the services of people who are not intimately familiar with the project to play the "devil's advocate" role in order to detect oversights, transposing of parameters, and to take a second look at all requirements. The design review provides the designer with an opportunity to incorporate additional specifications and

to make a determination that the system will indeed perform the desired function for which it is designed.

6. The report provides insight into purchasing and inspecting components and/or subsystems, as the system moves into the implementation phase, before system fabrication actually begins. The more notable obstacles encountered during the fabrication and assembly process are highlighted. Then methods of integrating the system are discussed. Both the system hardware integration and software are discussed. The software selection criteria are organized to ensure that they perform the necessary functions efficiently and that they are compatible with the hardware and the operating system.

7. The system installation section discusses the factors necessary to prepare the installation site, including: power availability, data lines, and space requirements. After the installation is completed, methods of checking system documentation are recommended. The importance of complete documentation in relation to future system maintenance is also stressed.

8. A recommended maintenance philosophy aids in the formulation of specific maintenance schedules for each type of system. Maintenance schedules are based, in part, on the operating environment and must be fine tuned as historical data are gathered. Various aspects of a suitable maintenance program are listed in a way that facilitates the development process.

9. The system designer and maintenance technician should find this report very helpful in that a logical approach is used to walk through the steps involved in designing an instrumentation system and a maintenance program. The end result is a system which performs as expected and remains operational for many years.

PART II: SYSTEM REQUIREMENTS DOCUMENT

10. A logical approach to specifying operating requirements for any data collection and reduction system is to first define the broad objectives of that system. Answering several simple questions will assist in identifying these objectives:

- a. What information is needed?
- b. How often does the information need updating?
- c. In what form does the information need to be presented?
- d. What is the relative economic value of the information?

Having fundamentally defined the scope of the information needs, an engineer may now specify the general requirements of an instrumentation system to satisfy those needs.

11. Routinely, all operating requirements of electronic instrumentation and data acquisition systems may be broadly categorized into two types: 1) functional, and 2) environmental. Functional and environmental requirements may be formally compiled, tabulated, and described in a Systems Requirements Document as is contained in Appendix A. This document becomes the basic reference for actual system design.

12. Functional requirements include system operating parameters that are related to or influenced by functions of hardware and software.

13. Environmental requirements include all systems operating parameters that are influenced by external conditions, such as the natural and induced physical environment, and spatial distribution/constraints related to system installation.

Functional Requirements

Physical phenomena to be measured

14. Obtaining information by means of electronic instrumentation systems involves the measuring and monitoring of nonelectrical physical phenomena such as tilt, stress, pressure, etc. These nonelectrical phenomena are composed of one or more fundamental quantities of nature: length, time, mass, and temperature. The international measuring system sets up independent standards for these fundamental quantities. All other quantities (force, acceleration, displacement, etc.) are derived from these.¹

15. The process of breaking-down the physical phenomena to be measured into their fundamental quantities enables the engineer to better define the best type of measuring component (transducer) for the instrument system. In other words, the engineer should explicitly define and examine the nonelectrical quantities that must be converted to usable electrical signals. Ultimately, these electrical signals must reliably and accurately represent the value of nonelectrical quantities that, in turn, provide the desired/required information.

Resolution and accuracy

16. The term "measurement resolution and accuracy" simply implies to what degree the measured value represents the "true" quantitative value.² With respect to instrumentation systems requirements, the engineer must clearly define the degree to which measured quantities must reflect actual values in order to provide adequate information to satisfy the need. Typically, there is a direct relationship between cost and the degree of measurement accuracy and resolution, i.e., system costs increase and decrease with measurement accuracy and resolution requirements. Since the exact true value is generally unknown and indeterminable, the measurement accuracy and resolution

requirement should reflect the relative economic value of the desired information.

17. In quantitative measurement using electronic instrumentation, "resolution" is defined as the input increment that gives the smallest measurable numerical change in output. An engineer should not be confused with "threshold", the smallest measurable input itself; although both are generally specified in absolute terms or as a percentage of full-scale range of measurement. The resolution of a typical pressure measurement might be stated ± 0.01 PSID or 0.1% of full scale of the desired measurement range. The ability to detect and define a smaller incremental change in a quantity increases the ability of a measurement system to more closely represent the true value of the quantity. Any deviation from the true value for any reason is an error and is reflected in the system specification of accuracy. Total system accuracy (lack of error) is also generally stated in terms of a percentage of the full-scale range of measurement. Instrumentation measurement systems are typically composed of several fundamental elements, each performing a special function (Figure 1).³ The total system accuracy of a quantitative measurement is a function of individual element accuracies and may be computed using mathematical analysis. Conversely, if the overall system accuracy is specified, allowable errors for individual elements may be calculated.⁴ When properly designed and implemented, automated electronic instrumentation and acquisition systems are capable of measurement data with less than a two-percent (2%) total system error.

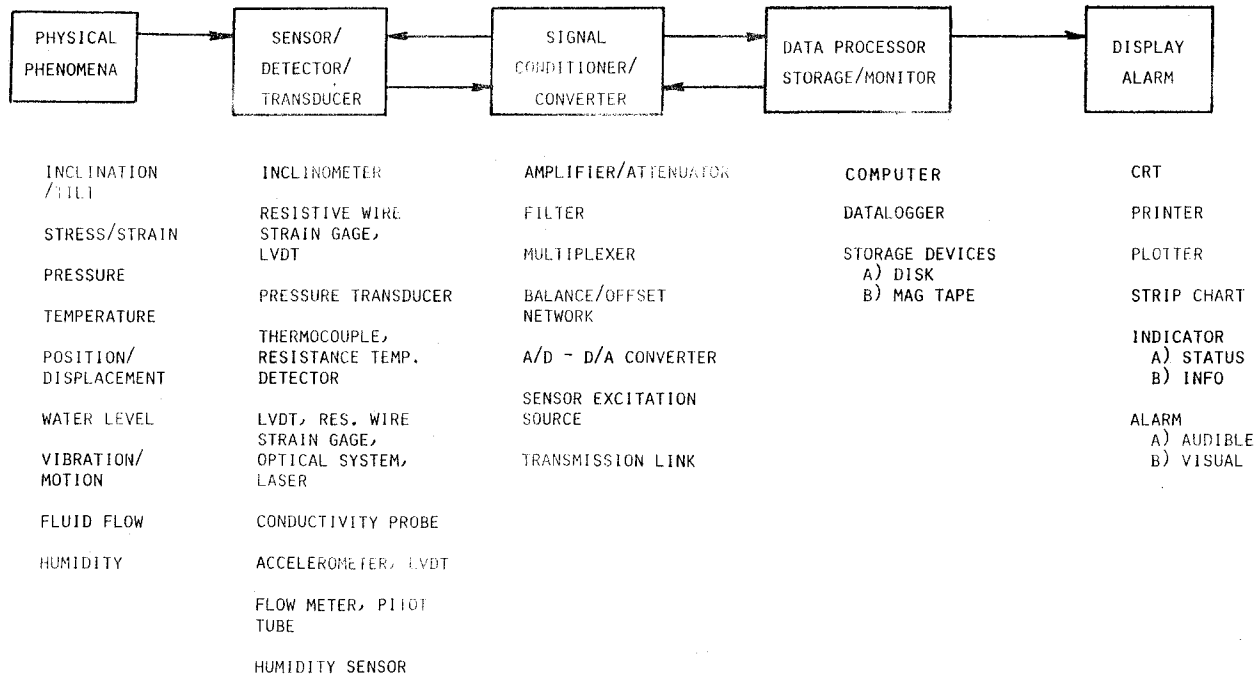

FIGURE 1. TYPICAL AUTOMATED INSTRUMENTATION/DATA ACQUISITION SYSTEM (EXAMPLES ARE LISTED UNDER EACH BLOCK.)

Reliability, criticality requirement

18. A significant requirement of an automated electronic instrumentation system is that it operates reliably, i.e., provides desired information for a given period under given environmental conditions.⁵ System reliability is influenced by five primary factors which must be considered in establishing this requirement. They are as follows:

- a. State-of-the art equipment. Recent developments in quality standards and reliability engineering within the electronics industry make automated hardware more durable and amenable to less than perfectly controlled operating environments. As a general rule, use of more recently developed instrumentation increases system reliability, and generally reduces the total cost of data over the life of the system.

- b. System complexity. As the number of subsystems and their assembled intricacy increases, instrumentation system reliability generally decreases. Consequently, simplicity or minimal complexity is the recommended approach to subsystem design and integration.
- c. Environmental conditions. System reliability generally decreases with increased severity of environmental conditions to which the components are exposed. Electronic instrumentation used at dams and concrete structures is typically exposed to severe environmental conditions. Subsystems involving critical measurements should be environmentally protected wherever possible.
- d. Operating time. All active components have a limited operating life. Reduction of continuous operating requirements to intermittent or cyclic functions generally extends the life of subsystem components.⁶ However, many of today's digital computers and subsystems are adversely affected by electrical and thermal cycling and should not have the power cycled frequently.
- e. Preventive maintenance. Proper and periodic maintenance increases system reliability and extends its operating life.

19. Consideration of these reliability factors is very important in subsystem applications that: 1) monitor critical functions over extended periods; 2) have components that cannot be easily replaced as they become inoperative; or 3) do not have skilled maintenance personnel readily available. Many subsystems used to collect and process data on concrete structures may have one or more of these characteristics and should have component redundancy to increase reliability to an acceptable level. A typical example of this requirement is the installation of multiple sensors in concrete structures during construction. These sensors are inaccessible and irreplaceable after installation is complete.

Sample rate and frequency of interest

20. An automated electronic data collection, processing, and storage system performs these functions at high throughput

rates and compiles enormous amounts of information. The engineer must determine the frequency at which any given parameter must be measured, processed, and recorded. Typically, with seismographic instrumentation, parameter monitoring may be continuous but measurement values are intermittently recorded and/or alarms triggered by predetermined system conditions. Such conditions might include, but are not limited to:

- a. Measured values exceeding predetermined set points.
- b. System being programmed to periodically sample and process assorted parameter measurements according to a precise schedule of varying time intervals.

21. The use of programmable, microprocessor-based data acquisition systems and test equipment provides the user with flexibility to easily modify measurement rates (sample and process speed) with software, and expand data storage capacity (memory or magnetic disk). System process speed is not a critical consideration for accurate measurements of relatively slow changing quantities, such as those frequently monitored by the COE. However, if an accurate time history of rapidly changing phenomena (active seismic data) is required, the system sample and process rate becomes critical. The Shannon sampling theorem shows that more than two samples per cycle of the highest frequency appearing in the changing phenomena are required to obtain a minimally accurate representation of those changes.⁷ Generally, the sampling frequency and system response should be an order of magnitude greater than the maximum data frequency expected to be recovered by that system.

Signal distribution and acquisition

22. Distribution and acquisition of electronic signals from numerous sensors and instruments geographically dispersed and perhaps remotely located from the computer or data processing unit constitutes a requirement for one of two primary approaches for system architecture. If the application is small, with

signal sources close together, a centralized system consisting of the processor, input/output (I/O) boards, signal conditioning modules, interconnecting cabling and sensors will be adequate, and is generally recommended. However, larger applications, or applications in which the signal sources are geographically dispersed (typical of COE dam sites), may require remote front ends or distributed intelligence in the data acquisition system (DAS) architecture.

23. In a centralized DAS, I/O hardware and signal conditioning modules reside in or next to the computer chassis with field wiring and cabling providing the signal link for sensors and communications bus for peripherals. A centralized architecture keeps the amount of software needed to a minimum and the application software is simplified because one computer handles everything. However, wiring and cabling may be expensive and prohibitive unless all signals are relatively near the computer. This architecture routinely requires a larger computer and, by its singular nature, reduces system integrity; if the central unit fails, or is down for maintenance/program modification, the whole system is down.

24. For applications that are physically spread out, or that must measure data from an environment too harsh for a computer, a distributed or decentralized architecture is a recommended alternative. The two types of systems in this category are those with remote front ends, and those with distributed intelligence.

25. Nonintelligent remote front ends are essentially termination boxes or conduits, or conduits that funnel information to and from the central computer. They may contain signal conditioning and conversion, data storage, and simple communication with the host computer. Their advantage is that they store data and save on wiring because sensor signals only

have to be wired to the nearest remote box. However, due to limited buffer memory, large data collection via remote front ends can be slow and cumbersome to the host computer.

26. A system with distributed intelligence consists of many small micro computers embedded in front-end boxes with I/O terminations. An intelligent front end can be programmed from the host computer to acquire and process data, make decisions about the acquired data, and generate control outputs. Many data loggers are typical examples of intelligent front-end devices. Extra processors off-load the host computer and keep the communication link (radio frequency (RF) telemetry, Electronic Industries Association (EIA) RS-232-C, Institute of Electrical and Electronic Engineers (IEEE)-488 standard interfaces, etc.) relatively free by sending only essential or critical data.⁸

Computation requirements

27. The systems engineer must make a reasonable estimate of the volume, speed, and complexity of computations that an automated data collection and reduction system will be required to perform in a particular application. Relatively simple conversions and mathematical functions may be performed by individual hardware elements (analog signal conditioning and recording devices) in one and two data-channel systems. However, for automated multi-channel, multi-function data acquisition and processing, a microprocessor-based instrumentation system and supporting software is recommended.

28. Multiplexing numerous data channels, performing complex data conversion operations, formatting/reducing data for display or storage, and controlling system peripherals are simple, time-shared operations for a computer-based instrumentation system. The major considerations for the systems engineer are identifying: 1) maximum system operating speed and

storage capacity requirement for programs and data; and 2) available sources of system operating software.

Alarm, display, and/or recording equipment

29. A fundamental function of an instrumentation system is to present desired measurement data to the user in a form that satisfies information needs. Thus, the systems engineer must explicitly define those requirements for acquired data display, storage, or special processing functions such as limit/alarm control for inclusion into preliminary design considerations. Computer-based instrumentation systems provide versatility and adaptability to a vast array of data output modems and methods. Real-time display of processed measurement values may be made on digital meters, video screens, multi-axis plotters, chart recorders, etc. Data may be tabulated, formatted, and printed in hard copy on command by the user or a preprogrammed schedule by software. Also, all data may be recorded (stored) on magnetic disk or magnetic tape for future processing.

30. Definitions of these general data output requirements predescribe the hardware and software operating subsystem. If the application requires real-time measurement and display/alarm, data acquisition should be made with a real-time multitasking operating system. By servicing each I/O task in turn on a round robin basis, a real-time operating system provides interactive display and alarm status monitoring while always servicing each data channel in a predictable amount of time. Real-time capability allows a data acquisition system to handle many I/O operations in a meaningful time span.

Power requirements/availability

31. To be operational, any electronic system must have sufficient electrical power (Watts) available, and in the proper form (AC/DC). Consequently, an automated electronic system

requirements list must include considerations for power provisions. Obvious factors that are pertinent include:

- a. Specific power requirements for individual instruments. Most instruments that are commercially available in the United States use 120 VAC, 60 Hz line power, but vary widely in current usage. Most instruments that require direct current contain internal power supplies or batteries with line charge capability. If computer back-up or uninterruptible power is not economically feasible, the design engineer should ensure that the operating program is in read only memory (ROM) instead of random access memory (RAM) so that the system will automatically restart after a power failure.
- b. Alternative direct current power sources (batteries, photovoltaic cells, etc.) and power inverters must be installed if the electronic system is likely to be located in a remote area with no available line power.

32. Generally the power requirements of an electronic instrument or system increase with its level of sophistication. However, each application has to be evaluated on its own merit, i.e., the measurement and subsequent data system configuration determine the power requirement.

Power backup and conditioning requirements

33. Power backup and conditioning may be required for automated electronic instrumentation systems in order to ensure that a temporary power anomaly does not interrupt or prevent critical data acquisition. The effects of AC line voltage problems such as transient noise spikes, dropouts, etc., may be minimized with the use of proper hardware and software in computer-based systems. Several basic considerations should be made by the COE with respect to this system requirement:

- a. The relative economic value and/or criticality of a temporary or small data loss must be weighed against significant costs for backup computer power hardware such as motor generators, uninterruptible power systems (UPS), line isolation, and regulation transformers, etc.

- b. Backup power sources, especially UPS, are generally inefficient. Efficiency ratings of only 35-40% are common for such units.
- c. With the exception of seismographic data, COE structural measurements generally aren't monitored on a continuous basis.
- d. State-of-the-art computer applications routinely use software that collects, processes, and moves data into permanent storage at speeds that prevent more than miniscule loss of collected data if a hardware anomaly occurs.

Environmental Requirements

34. To complete the general requirements for design of an automated instrumentation and measurement system, the engineer must identify the major elements and range of the natural and induced physical environment to which specific subsystems will be subjected during operation. System performance and reliability depend, to a large extent, upon the proper match of instrumentation and its operating environment. Compatibility may be achieved by one or a combination of two general means: 1) select and apply instrumentation capable of functioning within the expected range of environmental excursion/exposure; or 2) condition/modify the environment to comply with available instrumentation operating requirements. Application of these methods partly determines the specifications for instrumentation hardware and/or system installation requirements.

Natural environment

35. Natural elements of the physical environment include temperature, humidity, vibration, pressure, dust, dirt, etc. The design engineer specifies instrumentation subsystem components that are functional within a range of each applicable element. The following recommendations deserve particular consideration for the COE with regard to natural environmental conditions at typical dam sites:

- a. Uncontrolled environmental excursions are generally excessive for typical automated instrumentation, especially data processing and reduction equipment. Environmentally controlled enclosures are recommended for computer-based and other sophisticated equipment.
- b. Since exposure duration bears upon equipment survivability under of severe natural environmental conditions, certain measurement and processing applications at COE sites may be handled better by using portable or mobile data acquisition systems. Such systems would be subjected to environmental extremes only during actual measurement and storage of raw data. The system might then be returned to a controlled environment for data processing and display.

Induced environment

36. Induced elements of the physical environment include electromagnetic and electrostatic interference, the technical skill of system operation/maintenance personnel, and spatial factors such as geographic and geometric distribution and size limitations of subsystem components. Definition of induced or created environmental elements is generally more difficult than those of the natural physical environment. These factors are often dependent upon and changeable with the scope and application of particular instrumentation systems. Certain functional characteristics of a system may influence these environmental elements and predicate design requirements and considerations. Examples of these are:

- a. Electromagnetic and electrostatic interference, and field sources of electrical signal noise may be self-generated by instrumentation power generators. These are more damaging to existing subsystems that are improperly shielded. The system design engineer must identify and minimize large generators of electromagnetic and electrostatic fields and maximize proper shielding and ground plane techniques in retrofitted instrumentation.
- b. Skill level requirements of personnel responsible for proper system operation/maintenance are generally a direct function of system sophistication and complexity. The system application engineer should appropriately match the instrumentation application

with available personnel skills in order to reduce additional training-related costs and hardware/software problems.

- c. Installation of additional instrumentation equipment requires space and appropriate placement within an allocated area. Specific considerations include:
 - 1. Centrally locating system components facilitates efficient operation and maintenance and reduces interconnection requirements, a major source of hardware problems.
 - 2. Equipment must be accessible for maintenance or repair, or otherwise be considered expendable.
 - 3. Instrumentation that requires frequent interaction with a human operator, i.e., control and display panels, etc., should be adequately accessible, lighted and labelled. Adding remote operator functions significantly increases the cost of an existing instrument and requires expert engineering skills.

Sample Form of System Requirements Document

37. The following is a sample form of the System Requirements Document that appears in Appendix A. The sample is completed with realistic entries to guide the user in describing the function and environmental requirements of an automated data acquisition system. However, these descriptions should not be interpreted as recommendations for any measurements under all circumstances or at all facilities. Each COE facility will likely have different requirements and should be individually evaluated for automation of each measurement. This sample form serves simply as a realistic example of the types of information that should be included in an actual System Requirements Document for a COE instrumentation project.

SAMPLE ONLY

SYSTEM REQUIREMENTS DOCUMENT

Waterways Experiment Station
(Facility)

XXXX - XX - XXXX
(Contract)

Auto Data Acquisition
(System Name)

John Doe
(System Design Engineer)

August 22, 1985
(Date)

GENERAL FACILITY MISSION AND SYSTEM OBJECTIVES

At WES, the U.S. Army Corps of Engineers performs developmental research and engineering of structures located on rivers, lakes, and near coastal ocean areas. Instrumentation data collection has generally been a manual operation, both labor intensive and time-consuming. The Auto Data Acquisition System should be developed to automate structural instrumentation and the data collection process, fully utilizing computer and digital data acquisition methods. Data should be presented to the researcher directly in engineering units and/or stored on magnetic disk for preservation and filing.

FUNCTIONAL AND ENVIRONMENTAL REQUIREMENTS

1. Physical phenomena/measurements Uplift Pressure
- a. Range 0 - 200 PSIG
- b. Accuracy (total system) 0.5 PSIG
- c. Resolution (total system) 0.1 PSIG
- d. Sample/interest rate: _____ Continuous
X Intermittent _____ Frequency
- e. Display (real-time): X Yes _____ No
- f. Store/record: X Yes _____ No
- g. Number of measurements 3
- h. Alarm: X Yes _____ No
Limits: _____ Low X High
- i. Criticality: X High _____ Average _____ Low

2. Sensor/detector/transducer

Type Strain gage pressure transducer

Sensitivity 5mV/V/PSI NonLinearity 0.25% Hysteresis 1.0%max

Accuracy 0.25% FS Resolution 0.01 PSI Range 0-300PSIG

Maximum Residual Unbalance (zero offset) 1.0% FS

Temperature Compensation: X Yes _____ No

Excitation Power: 5.00 V _____ AC X DC
<.025 A X Reg. _____ Unreg. _____ Hz

Number of Instruments 3

Environmental

Operating temp 0-50 °C Humidity 10 - 100%

Shock/Vibration Min Other hazards 50% overpressure

Protective enclosure: Yes No

Mechanical

Physical dimensions < 5 in³ / sensor

Mounting Bracket Spatial None

3. Signal Conditioner/Converter

a. Amplifier

No. of channels 10

Single-ended Differential

Gain-Fixed Variable Range 1 - 100

Automatic/Manual Auto

Accuracy 0.01% Bandwidth 10kHz

Environmental

Operating temp 0-40 °C Humidity 20-80% noncondensing

Shock/Vibration Min Other hazards None

Protective enclosure: Yes No

Mechanical

Physical dimensions < 4 ft³ / rack

Mounting Modular rack Spatial 10 channels / rack

b. Filter

Type: Low-pass High-pass Band-pass

Cut-off Frequency 1-10kHz Fixed Variable

No. of channels Integrated in amp module

Environmental

Operating temp 0-40 °C Humidity 20-80% noncondensing

Shock/Vibration Min Other hazards None

Protective enclosure: Yes No

Mechanical

Physical dimensions _____ See "Amplifier" _____

Mounting _____ Spatial _____

c. Balance 100mV Offset 1VDC Compensation None

d. Multiplexer

1. Analog: Low level _____ High level X

No. of inputs per output 16

Input: Single-ended X Differential _____

Input voltage range 10V Sample rate 10 ch/sec

2. Digital: Parallel _____ Serial X

Bits/word 8 No. of channels 100

Address code type Binary (BCD, binary, etc.)

Logic levels: High > 3.8 V Low < 0.8 V

Logic convention: Positive X Negative _____

Sample rate 10 ch/sec

Environmental

Operating temp 0-40°C Humidity 20-80% noncondensing

Shock/Vibration Min Other hazards None

Protective enclosure: _____ Yes X No

Mechanical

Physical dimensions _____ < 5 ft³ / unit

Mounting 19" rack Spatial < 15" vert. rackspace

e. Signal Converter

Type: Analog-to-Digital (A/D) Successive approximation

Input range 10V Conversion speed 1.0 usec

Bits of resolution 12

Digital-to-Analog (D/A) Ladder
Bits of resolution 12 Conv speed 5 usec
Output Range 10V

Environmental

Operating temp 0-40-°C Humidity 20-80% noncondensing
Shock/Vibration Min Other hazards Dust/static chg.

Mechanical

Physical dimensions < 1 ft³ / unit
Mounting 19" rack Spatial < 4" vert. rack space

f. Sensor Power Source: X YES No
AC DC X Hz Reg X Unreg
Voltage 5.00 Amperage 2.0 Backup: X Yes No
Battery X UPS Solar

Environmental

Operating temp 0-40-°C Humidity 20-80% noncondensing
Shock/Vibration Min Other hazards None

Mechanical

Physical dimensions < 3 ft³ / modular rack
Mounting Modular Spatial None

g. Transmission Link

Wire/cable X Telemetry Telephone Modem
Fiber-optic Other

Environmental

Operating temp 15-100-°C Humidity 10 - 100%
Shock/Vibration Min Other hazards EMI

Mechanical

Physical dimensions _____ < 6" diameter / harness _____

Mounting EMI shielded conduit Spatial None

4. Data Processor/Storage/Monitor

a. Computer

Purpose: Data acquisition X Process control _____

Data reduction X Computation X

Other Alarm-condition monitoring

1. Peripherals: Monitor X Plotter X

Printer X Mag. tape X Modem _____

Hard disk _____ Disk drive _____ Floppy disk X

Terminal _____

2. No. of input data channels: 128

Analog _____ Digital X

3. Main memory: Type SRAM Capacity 500 kbytes

4. Communications: I/O port(s); 4-20mA _____

IEEE-488 X RS-232-C X RS-422 _____ RS-449 _____

16-bit parallel X

5. Power: Primary X Backup X

120 V AC X DC _____ Amps 30 Freq 60Hz

Backup: Battery _____ UPS X Solar _____

Available: X Yes _____ No _____

6. Grounding scheme Single-point

7. Network configuration Star

Environmental

Operating temp 15-20°C Humidity 10-80% noncondensing

Shock/Vibration Min Other hazards Dust/static chg
Cooling rqmnts Fans Dehumidification Room A/C

Mechanical

Physical dimensions Desktop Personal Computer

Mounting Desktop Spatial 3' X 5' table

Portable _____ Fixed X

b. Data Logger

Data input: Analog X Digital X Sample rate 10 ch/sec

Hard copy _____ Internal storage X Memory cap. 64k

Resolution 5mV

Remote communications: Modem _____ RF _____ I/O RS-232-C

Alarm: Audible X Visual Flashing LED

Power: Primary X Backup X

120 V X AC _____ DC 10 Amps 60 Hz

Backup: Battery X UPS _____ Solar _____

Available: _____ Yes X No

Grounding scheme Single point

Environmental

Operating temp 0-50-°C Humidity 10 - 100%

Shock/Vibration 5g's Other hazards Envir. cond. encl.

Mechanical

Physical dimensions < or = 4 ft³ / unit

Mounting Carrying Case Spatial None

Portable X Fixed _____

c. Storage Devices: Disk drives 2 Mag tape units 1

1. Disk drives: Avg access time 5 milliseconds

Unit capacity 115 kbytes/side Controller Dual
Floppy X Hard _____ Fixed _____ Removable _____
Power: Primary _____ CPU _____ Backup _____
_____ V _____ AC _____ DC _____ Amps _____ Hz
Backup: Battery _____ UPS _____ Solar _____
Available _____ Yes _____ No
Grounding scheme _____ Single point

Environmental

Operating temp 10-50 °C Humidity 10-80%noncondensing
Shock/Vibration _____ Min _____ Other hazards Dust

Mechanical

Physical dimensions _____ Integrated with CPU
Mounting Tabletop _____ Spatial _____ None _____
Portable _____ Fixed _____ X

2. Magnetic tape unit:

Bits per inch (BPI) 800 Tape speed 75 ips
7-track X 9-track _____ Reel Size 10.5"
Tape width 0.5"
Power: Primary _____ X _____ Backup _____ X
115 V _____ X _____ AC _____ DC 10 Amps 60 Hz
Backup: Battery _____ UPS X Solar _____
Available _____ Yes _____ No
Grounding scheme _____ Single point

Environmental

Operating temp 0-50 °C Humidity 10-80%noncondensing
Shock/Vibration _____ Min _____ Other hazards EMI

Mechanical

Physical dimensions < or = 5 ft³
Mounting Tabletop Spatial None
Portable Fixed X

5. Displays/Alarms

a. Cathode Ray Tube (CRT)

1. Resolution: X High Low
Video: X Composite RGB
Screen size 14" Color Monochrome X
Power: Primary X Backup X
115 V X AC DC 2 Amps 60 Hz
Backup: Battery UPS X Solar

Environmental

Operating temp 0-50°C Humidity 10-80%noncondensing
Shock/Vibration Min Other hazards Fragile

Mechanical

Physical dimensions As required
Mounting Tabletop Spatial Eye level
Portable X Fixed

b. Printer

Type: Character X Line
Letter quality Dot matrix X
Communications port: Serial X Parallel
Data buffer: > or = 4k Yes No
Paper: X Tractor feed X Friction feed
Fan fold X Roll Width 9.5"

Type font(s) Regular, compressed, proportional

Power: Primary X Backup
115 V X AC DC 3 Amps 60 Hz

Environmental

Operating temp 0-50-^oC Humidity 10-80% noncondensing
Shock/Vibration Min Other hazards Dust

Mechanical

Physical dimensions As required
Mounting Tabletop Spatial Easy access
Portable X Fixed

c. Plotter(s)

Type: Roll Flat bed X
Plot size 11" X 14" No. of pens 6
Communications port: Serial X Parallel
Data buffer: > or = 4k Yes No
Paper size 11" X 14" Fonts Regular, bold, comp.
Power: Primary X Backup
115 V X AC DC 3 Amps 60 Hz

Environmental

Operating temp 0-50-^oC Humidity 10-80% noncondensing
Shock/Vibration Min Other hazards None

Mechanical

Physical dimensions < or = 20" X 20" table surface
Mounting Tabletop Spatial None
Portable X Fixed

d. Strip chart recorder(s)

Type: Pen & ink 1 Heated stylus _____ Point plot _____

Signal input: Sensitivity Var _____ Freq. response 10Hz

No. of channels 2

Power: Primary _____ X _____ Backup _____

115 V _____ X _____ AC _____ DC 5 Amps 60 Hz

Environmental

Operating temp 0-50 °C Humidity 10-80% noncondensing _____

Shock/Vibration Min _____ Other hazards None _____

Mechanical

Physical dimensions As required _____

Mounting Tabletop _____ Spatial None _____

Portable _____ Fixed X _____

e. Indicators

Type: 1. Status: LED 10 Incandescent 2 _____

Other _____

2. Information: Digital 3 Analog 1 _____

LED 2 LCD _____ Dial/Meter 1 _____

Gas discharge 1 Pointer/Scale _____

Other _____

Power: Primary _____ X _____ Backup _____

5 V _____ AC _____ X _____ DC 5 Amps _____ Hz

Environmental

Operating temp 0-50 °C Humidity 10-80% noncondensing _____

Shock/Vibration Min _____ Other hazards None _____

f. Alarms

Type: Audible 1 Visual 5 Remote
Local X

Power: Primary X Backup UPS
 115 V X AC DC 2 Amps 60 Hz

Environmental

Operating temp 0-50 °C Humidity 10-80% noncondensing

Shock/Vibration Min Other hazards None

PART III: SYSTEM DESIGN

38. One of the primary problems faced by the design engineer is the determination of system requirements which are necessary in order to design and develop an instrumentation system. To help reduce those problems to a manageable level, a logical approach to system design is discussed and the key factors highlighted. It is only then the system building blocks will begin to fall in place.

System Considerations

39. Once the requirements are established and a search for system components begins, a primary concern (intended or not) becomes a cost versus performance situation. Choosing a system that meets the minimum requirements with the best cost/performance ratio is not always the best solution. A system that meets the minimum requirements now might not meet future requirements. At that point, the whole system must be replaced. If a system is chosen for future expansion, the cost of an expansion unit is far less than a total system. It is best to select a system that may have specifications and capabilities beyond the current requirements. This assures that the system will not be pushed to its limits while allowing for future needs.

40. If a manufacturer goes out of business or cancels the product line, problems with spare parts, maintenance, and expansion can arise. The stability of a manufacturer and the extent of his support are of great concern. Talking with other users of like or similar systems provides a good input for rating a manufacturer. A check of the company's financial standing is also recommended.

41. System architecture influences speed and ease of access to the system. The central processor unit (CPU) is

generally an 8-, 16-, or 32-bit unit. This describes the width of data paths internal to the CPU. The wider path is capable of handling larger numbers faster. Central Processing Unit speed is rated by cycle time. Each cycle requires a certain amount of time, according to the CPU clock. Each instruction requires a certain number of cycles; therefore, the time required for a process is the number of cycles required multiplied by the cycle time. The power and speed of a computer is also determined by its instruction set. An instruction set is a group of commands used to accomplish various operations. The CPU is generally the fastest unit in a system, consequently, the CPU spends time waiting for peripherals such as magnetic disk units, magnetic tape units, terminals, etc.

42. The efficiency of the computer is strongly linked to the language used, i.e., COBOL, FORTRAN, BASIC, etc. All have certain advantages and disadvantages depending upon their use.

Automated measurement techniques

43. The goal of any automated measurement system is to describe accurately a physical quantity or property in a humanly interpretable form. The three essential elements of a measurement, as follows:

- a. Measurand. The physical quantity or property being measured.
- b. Reference. The physical quantity or property to which quantitative comparisons are made.
- c. Comparator. The means of comparing measurand and reference to render a judgment⁹.

44. The objectives of a measurement are to obtain information about the measurand, provide a record or historical profile of the measurand (especially under varying conditions), and/or control where the measurement information is used to

produce some action. In an automated system, this entails information acquisition, processing, and output.

45. The extremely powerful, versatile, flexible and inexpensive digital computers now available provide the best means for acquiring, processing, storing, and outputting measurement information. The size and cost of the system depends upon the extent of processing, number of measurements, and the frequency of measurement. If storage of data is the only purpose of a system, the cost is low. Some means of displaying and/or processing must be provided elsewhere. Simple storage systems may be either portable or fixed.

46. When using digital systems, the result of a measurement is a digital word which represents the physical quantity or property measured. There are several methods of producing this digital word. All of these methods involve elements or transducers which are either electrically excited or self-generating. An electrically excited element or transducer is one which requires energy input to produce an energy output. A self-generating element or transducer has a self-contained energy source.

47. These elements produce a voltage, current, or frequency which represents the quantity or property being measured. This is accomplished by varying inductance, light, capacitance, or resistance. The output must be digitized for use by the computer system. It may be digitized at the source for transmission, or at the system. When signals are digitized at the system, care must be employed in the transmission of the signal. Transmission of digital signals may be checked by several means to assure that what is transmitted is what is received. Digital signals have a high noise immunity. Low-level (mV or below) analog signals are the most critical in high-noise environments.

48. Computer systems offer means to calibrate and compensate for system errors to assure accurate readings. This is a big advantage in an automated system. Most front end manufacturers offer signal conditioning with multi-channel analog-to-digital (A/D) converters. Depending upon the type of input device, signal conditioning consists of amplification, bridge completion networks, thermocouple compensation, excitation voltage and current supplies, and filtering.

49. The more accuracy and precision required, the more the system costs. Therefore, only the minimal accuracy and precision required for interpretation of the data should be specified for the system. There is also the consideration of maintenance and calibration costs rising with greater accuracy and precision.

Component compatibility

50. In choosing components for a system, beware of the manufacturers' exaggerated claims of compatibility and performance. The best way to determine compatibility is to connect the units and observe their operation. However, when this is not possible, exact specifications for the two or more units contemplated for use should be examined by a competent engineer or technician to check all parameters for compatibility. In developing a system, try to avoid special interface requirements. Special interfaces are generally expensive and sometimes difficult to maintain. Also, avoid requirements for special software drivers as software development costs are generally higher than hardware development costs.

Instrument/system characteristics

51. Matching the instrument to the system is a critical part of system integration. For voltage output instruments, if the voltage level of the instrument does not match the voltage level of the system input, signal conditioning must be added. The range and resolution of the reading must also be considered.

Some system "front ends" are more flexible than others because they allow various levels, ranges, and resolutions by the use of programmable gains. Programmable gain and other forms of signal conditioning add to the cost of a system.

52. If an excitation voltage is used, provisions should be made for a system to read this voltage for calibration purposes. The distance between the transducer and the data system is a consideration because of line loss and interference. Signal drivers may be necessary over long leads. Also, shielding and filtering may be necessary to reduce electromagnetic interference (EMI) on long leads. This is especially true in harsh electrical environments.

Interfacing techniques

53. There are several standard interfacing techniques presently available. Using them is recommended since nonstandard interfaces make system integration a difficult task. Choosing an interface technique depends on distance, required transmission speed, and environment. There are two basic types of interfaces: 1) serial, and 2) parallel. In some cases, combinations are used. In general, parallel is faster and more expensive.

54. The Institute of Electrical and Electronic Engineers (IEEE) IEEE-488 standard instrument bus is the most popular parallel interface. It is 8 bits wide and is capable of speeds of up to 1 Mbyte throughput. Its limitations are distance and number of devices (30 meters and 15 devices).

55. The 16-bit parallel interface is a standard interface in that it is commonly used. However, handshaking, status bits, command bits, drive capabilities, and speed are nonstandard. The 16-bit parallel interface is, however, one of the fastest ways to transfer data.

56. The Electronics Industry Association (EIA) RS-232-C standard is the most popular serial interface. Its limitations are distance and numbers of devices (17 meters and 1 device). Caution must be taken when using this interface because the standard is not strict enough to prevent two devices from having differences such that they will not communicate with each other. Baud rates (bits per second) of 19.2 kbaud are possible, depending upon the interface.

57. The EIA RS-422 standard interface is a differential version of the EIA RS-232-C standard. The RS-422 is capable of transmitting over longer distances and at higher speeds (100 meters and 100 kbaud) than the RS-232-C standard interface, and has better noise immunity.

58. The 20-mA current loop is also a popular serial interface that may be used for transmission of data up to 180 meters at baud rates of 9600. Greater distances may be attainable by using lower baud rates.

59. The EIA RS-449 standard serial interface has good noise immunity and baud rate, but handshaking slows the throughput rate.

60. Another low cost interface is the Hewlett-Packard interface loop (HP-IL). This is a very simple two-wire link and is used on instruments, hand-held calculators, and computers. This link uses a loop configuration and can transfer 5 kbytes per second.

61. Fiber-optic links are serial interfaces which are higher in cost, but provide definite advantages. The major advantages are: 1) speed, 10 Mbaud to 1 Gbaud; 2) complete electrical isolation; and 3) no electromagnetic interference (EMI). These interface links are excellent for use in

electrically harsh environments. Fiber-optic links usually transmit over 1 to 3 kilometer lengths at their specified baud rate without repeaters. Links are available to transmit over greater distances, but they are more expensive.

Power Sources

62. Commercially available power is sometimes insufficient to power systems and instruments because of excessive noise, voltage fluctuations, and drop-outs. Less severe conditions can be overcome by using line conditioners. Several line conditioners are available which isolate and regulate voltage, filter noise, and protect against transients. More severe conditions could require the use of a motor-generator set which provides the same functions as line conditioners, but at a higher level. Motor-generator sets provide much better protection, especially for drop-outs. If power failures are intolerable, an uninterruptible power system (UPS) should be considered. These systems monitor the input power and switch to a back-up system (battery, diesel generator, etc.) when there is a power interruption. Special attention should be given to the UPS switching time specification to ensure continued system operation during a power interruption.

63. At sites where commercial power sources are not available, system instrumentation should be chosen to operate with minimum power consumption to reduce backup power system costs. To supply the required 120 VAC at these locations, commercial inverters and batteries may be used. Inverters convert a DC voltage to AC voltage at reduced efficiency and increased cost. Photovoltaic generators (solar cells) may be used to maintain trickle charges on batteries used as primary power sources. Other considerations for charging batteries are thermoelectric and wind-powered generators. If these sources are not adequate for system requirements, gas or diesel-powered generators may be installed at most COE sites. Small

hydroelectric generators may also be used where adequate water-generated energy is available.

Grounding techniques

64. Grounding is a very critical system consideration. When several points are used for ground, the possibility exists for a potential difference between those points. This causes a current flow from one point to another through the ground lines and thus an imbalance in the system. This condition is called a ground loop. Grounds are also subject to conducted interference. The best system for grounding is to establish a single point for ground which is referenced to incoming power. All grounds should be referenced to this point. When it is necessary to establish a ground at a remote site, isolation should be used at the host system end. Several methods are available for isolation depending on the type of signal used.

65. For digital systems, the least expensive and most effective method of isolation is the opto-coupler. Several isolation amplifiers are available for analog systems. AC signals may be isolated by using isolation transformers.

66. Analog and digital grounds should be separated except at the single system ground point.¹⁰ Cable shields should be grounded at the source end only. Equipment cabinets should only be grounded through a bus to the single ground point. Heavy gage copper wire should be used to connect grounds to the single ground point. The single ground point should be a copper bar or plate.

67. It has been the experience throughout the Corps, that damage from lightning strikes and other forms of circuit overload can become a serious problem, causing many dollars in damage. Some form of isolation and line conditioning should be used between the system and commercial power, and in areas where

lightening is likely to disturb the instrumentation. This prevents disturbances on the commercial power lines from damaging the system, and lightening from damaging sensitive circuits that may be contained in some of the field instrumentation. One lightning strike several miles away could bring the system down and result in costly damage. The system should be located as far away as possible from AC power equipment, such as generators, heavy motors, etc. High-isolation power transformers can be installed in the system to prevent erratic line current fluctuations from reaching the system. Where instruments are subject to lightening strikes the installation of isolation equipment or additional grounding circuitry can prevent serious overloads to sensitive circuits.

Maintainability

68. System mean time between failures (MTBF) and downtime influence the operation of a system. The MTBF is a consideration when choosing a system. Downtime may be shortened by choosing a system with good maintainability. The type of maintenance used influences downtime. This aspect is covered in PART VI of this report. The system design and documentation are controlling factors in maintainability.

69. When reviewing a system design for maintainability, one should check for ease of access to components for test purposes. If the system uses plug-in printed circuit cards, an extender card should be available to aid troubleshooting. If the system has a modular construction, the modules should be of reasonable size and perform a particular function. This enables a "board swapping" approach to troubleshooting and minimizes system downtime. A defective board can be repaired while the system is in operation. This approach requires stocking of spare boards. System design also influences maintainability by the type of parts used. If parts are rare and unusual, the availability becomes a problem. Always ensure that the

manufacturer can support the unit and that parts lead time is not excessive. Check with other users of the same or similar systems for problems that they may have had with maintenance of their systems.

70. Documentation should be clear and concise, yet detailed. It should include a general description, a theory of operation, a block diagram of the unit, installation instructions, a section on troubleshooting, a parts list, and logic or schematic diagrams. Even the best technicians are unable to repair a unit without this basic documentation.

Operability

71. The system operator is usually not able to program or repair the system; as a consequence, he does not understand the more highly technical aspects of the system. The ease with which a system functions determines the level of expertise required by the operator. Controls should be well labelled and easily understood. Try to avoid complex procedures for operation. The catch phrase now is, "user friendly", but it is sometimes misused. The more automatic the system, the less human intervention is required; consequently, the chance for operator error is reduced.

System calibration

72. System calibration is essential to verify the accuracy of the various readings taken by the system. Measurement errors are the quantitative difference between the true values of the measurand and the values indicated by the measuring system.¹¹ These errors may be classified as static errors, loading errors, and dynamic errors. Static errors result from the physical nature of the various components of the measuring system as that system responds to a time-invariant measurand input.¹² Loading errors result from the changes caused by the connection of the sensor to the measurand. Dynamic errors result from the inability of a measuring system to respond faithfully to a time-

varying measurand.¹³ System calibration does not affect loading errors and most calibration systems do not affect dynamic errors. System calibration can eliminate static errors. This section of the report is not concerned with maintenance calibration when the various components are removed from the system and sent to a laboratory for calibration (which should be a regularly scheduled occurrence). Here reference is being made to a calibration which takes place at the system site under normal operating conditions to eliminate any induced error from hardware limitations and external influences.

73. The most accurate method of calibration is to apply a standard physical quantity to the sensor and adjust the measurement system to the proper reading at several points over the range of the sensor. This method is costly and sometimes impossible to perform. The most common method is signal substitution. In this case, an electrically equivalent signal is substituted for the actual sensor output, and the measurement system is adjusted to the proper reading. The accuracy of a signal substitution type calibration depends to some extent on where the signal is injected. The highest accuracy is obtained by substitution as close to the sensor as practical. The measurement error in some cases may not be great enough to warrant the cost of injecting the signal at the sensor. In this case, signal substitution may be done at the data processing end of a remote measurement system.

74. During the calibration process, data channel reference levels and drift may be determined by short circuiting the input signal lines. When using computer-based measurement systems, programs may be written to compensate for offset, nonlinearity, etc.

75. A method of calibration used with bridge circuits or resistance measurements is the R-cal (shunt cal) method. This

method changes the active element of a resistance bridge by a precise quantity and provides one calibration point for a measurement system calibration.

76. Calibration should take place as close to actual and mean operating conditions as is feasible. A good example of this is calibration under extreme temperature conditions causing inaccuracies. Calibration points should be taken above, near, and below the range of values to be measured.

77. Generally, two types of reference standards are used in calibration. The primary standard is a standard which is directly traceable to the National Bureau of Standards (NBS) or a natural physical constant. Primary standards are seldom used in field measurement applications, but are used mainly under laboratory conditions. Secondary standards are those calibrated to a primary standard, and are normally used in field measurement systems as a reference for calibrations. The accuracy of the calibration standard should be a factor of ten higher than the desired accuracy of the reading. In some cases, a factor of three is sufficient, but this should be carefully researched.

System flexibility

78. System flexibility is enhanced by choosing a general purpose system as opposed to a special purpose system. Sometimes this causes a sacrifice of speed and/or accuracy. The first consideration for system flexibility is the number of I/O channels and communications ports the system is capable of handling. These capabilities may be limited to the unit itself or expandable through an expansion chassis. Most systems are expandable by use of a communications port and an intelligent front end. This type of expansion has several advantages. Intelligent front ends can perform tasks which take a load off the main system. This operation is referred to as distributed

processing. Another advantage of front-end intelligence is that it requires less wiring and speeds up system throughput. Intelligent front ends may also be used on remote sites where they can be controlled via a modem, radio transmission, etc. Some intelligent front ends and data loggers are capable of stand-alone operation where they gather and store data to be transmitted to a central system when requested.

79. The more memory and storage capability a system has, the more flexible it becomes. The sample rate of a system can also influence flexibility. Features designed into a system can increase flexibility, such as an alarm which automatically notifies an operator when a measured quantity exceeds specified limits. The amount and type of power required by a system can restrict its use, especially in remote applications. Environmental specifications tend to restrict system use also. The type of system bus used and the number of manufacturers who supply products for that bus influence flexibility. A local area network (LAN) is a bus structure which is usually supported by several manufacturers, but requires an intelligent controller on the bus. LANs can increase system flexibility by distributing access to the system. Remote terminals, controllers, data acquisition systems, printers, and computers can be linked to the system by a single bus. This provides a convenient way to reconfigure the system by adding or removing devices.

Economic factors

80. The material cost of the system is always an economic factor. The labor cost of programming, installation, check-out, and documentation must also be considered. Once the system is installed and working, maintenance becomes the major economic factor. The service offered by the manufacturer or his representative directly influences maintenance costs. Parts availability and cost also influence maintenance cost. The cost of downtime is a factor; the cost of expansion is another. The

replacement projection and cost should be considered. When life-cycle costs are evaluated, a system which costs \$10,000 and lasts five years isn't necessarily as good a buy as one which costs \$20,000 and lasts ten years.

81. A general purpose system as opposed to a special purpose system can be a more economical system. General purpose systems can perform tasks other than data acquisition. This variety of functions can sometime justify the purchase of a system for applications where a dedicated system could not be justified. A general purpose system can perform such functions as word processing, records keeping, security (such as fire and intruder warning), heating control, lighting control, process control, data reduction, and graphics generation.

82. Some other economic factors include, but are not limited to: supplies (paper, disks, magnetic tape, etc.), power costs (especially in remote sites), and operator time. Computer systems can perform so many tasks so quickly that the increased performance generally outweighs the expenditure of funds.

Sensors/Detectors/Transducers

83. In order to limit the scope of this report to COE applications, sensor types commonly used in automated instrumentation systems to measure and monitor phenomena relating to large concrete structures are reviewed. This review includes those "input transducers" that adhere to the following generic definition: "a device that converts a nonelectrical quantity or energy into a measurable, equivalent form of electrical energy with the required degree of accuracy." These transducers are actuated by physical variables such as force, pressure, temperature, flow, etc. They supply measurable electrical signals to the front end of a measurement and control system (which may range in complexity from a simple analog meter to a

multi-input, multi-output, multi-processor, multi-loop digitally controlled system¹⁴). The two broad classes of input transducers are identified by their input requirements. Many transducers (strain gage, bridge, linear variable differential transformer (LVDT), etc.) are three-energy port devices: physical input, electrical output, and an auxiliary electrical "excitation" input. Others are self-generating transducers (thermocouples, photovoltaic cells, etc.), and have only two energy ports. The electrical output of self-generating transducers is totally derived from their physical input.

84. Frequently, self-generating sensors have low-energy and nonlinear responses to physical changes and require additional signal conditioning to match system component requirements. On the other hand, these transducer types generally are simply structured, reliable, and intrinsically rugged. The primary trade-off of electrically-excited versus self-generating elements is in electrical output levels; excitation voltage often may be used to increase the output signal levels of active sensors and decrease requirements for amplification and other forms of signal conditioning.

85. Input or measuring type transducers and sensors are further classified according to the physical variable or phenomena being measured and the type of sensing element or transduction principle that is used. Table 1 lists physical measurement parameters historically encountered by the COE at large concrete structures and transduction principles commonly used to sense and measure those parameters.

Table 1 (continued)

| <u>Measurement Parameter</u> | <u>Transduction Principle</u> |
|------------------------------|--|
| VIBRATION-VELOCITY | Linear velocity transducers -seismic Integrated accelerometers signals |
| VIBRATION-ACCELERATION | Linear accelerometers -piezoelectric |
| HUMIDITY | Animal hair-mechanical linkage Lithium chloride, electrical resistance Capacitance Microwave Thermoelectric-optical servo |
| LINEAR VELOCITY (Speed) | Inertial mass-magnetic field -self-generating Pendulous mass-spring-LVDT -potentiometer Inductive-attached linkage -potentiometer Inductive-attached linkage -noncontact Optical-time differential -piezoelectric- -integrated ac- celeration |
| LINEAR ACCELERATION | Seismic mass-piezoelectric -piezoresistive -strain gage -LVDT -inductive -capacitance -potentiometer Force balance servo |

Table 1 (Continued)

| <u>Measurement Parameter</u> | <u>Transduction Principle</u> |
|--|--|
| ANGULAR DISPLACEMENT (Inclinometer) | Capacitor Inductive Resistor Photoelectric Strain gage LVDT (rotary) Gyroscope Shaft encoder, digital Pendulum-potentiometer Force balance-accelerometer -integrator Liquid-resistor |
| FLOW METERS | Positive displacement -volumetric-liquid Positive displacement -volumetric-gas Differential pressure-orifice -venturi -pitot tube Turbine-velocity-liquid-gas Magnetic-velocity Variable area-float meter -force meter Thermal-mass flow Differential pressure -mass flow Turbine-axial-momentum -mass flow |
| TEMPERATURE | Thermocouple-K-chromel-alumel J-iron-constantan B-Platinum -rhodium T-copper -constantan RTD-platinum-nickel -thermister Semiconductor junction Pyrometer-radiation-optical |

86. Several transduction principles and methods are applicable to primary COE measurement parameters, and consequently, are worthy of specific attention and discussion. Among these principles and/or transducer elements are:

- a. Resistive strain elements- unbonded wires- bonded foil gages.
- b. LVDT.
- c. Seismic mass acceleration- piezoelectric effect.
- d. Thermocouple/ resistive temperature element.

87. The principle of transduction with resistive strain gages is a result of the piezoresistive effect of strain on wire conductors which are made of certain alloys. The piezoresistive effect is the change in electrical resistance of the wire when stretched. Since wire resistance is directly related to strain, measurements of electrical resistance changes may be used to indicate structural displacement, deflection and/or force. These resistance measurements may be made directly with a precision instrument such as the Carlson meter or digital ohmmeter. Generally, resistive strain gages are configured in a Wheatstone bridge circuit such as shown in Figure 2 below. The bridge has four resistive elements, at least one of which is an active strain gage. The bridge is "excited" with a voltage, E_{in} , and if balanced, i.e., $R_1/R_3 = R_2/R_4$, the differential voltage at E_{out} is zero. A change in resistance of any element (bridge arm) results in a difference in potential at E_{out} . Consequently, changing resistance is translated to a changing voltage level which can be conditioned and processed by an automated instrumentation system. More detailed information relevant to Wheatstone bridges is given in Appendix B.

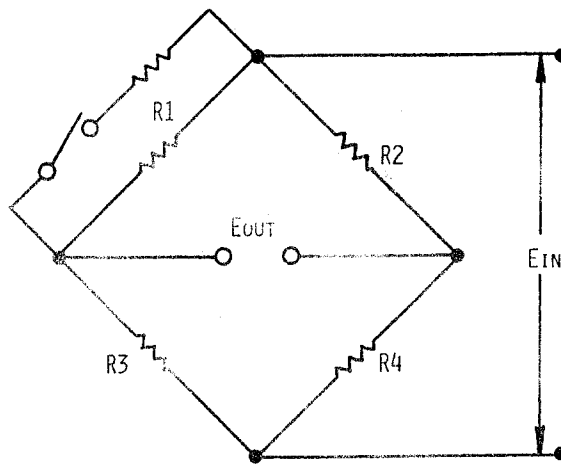

FIGURE 2. WHEATSTONE BRIDGE CIRCUIT

88. Linear variable differential transformer (LVDT) transducing principles are commonly used to transfer displacement and deflection measurements into electrical signals.¹⁵ The LVDT is a mutual inductance element. It produces an electrical signal that is proportional to the linear displacement of a movable armature or core. The LVDT has a simple construction. Basically two elements are involved with the LVDT, the armature and the transformer. The transformer has a stationary coil enclosed in a protective magnetic shield. The armature moves within the hollow core of the coil.

89. The LVDT coil has a primary winding in the middle and two secondaries, wired in series opposition. When the primary is energized by an AC current, the armature induces a voltage from the primary to the secondary winding. The position of the armature within the core of the coil determines the level of the voltage at each secondary. If the armature is placed precisely midway between the two secondaries (null position), the induced voltage in each secondary is equal and opposite, and there is no output. As the armature is moved in either direction away from null, the LVDT produces an output voltage that is proportional to the displacement of the armature from null and whose phase relationship with the primary supply shows whether the armature

has moved nearer one end or the other of the coil. Thus, for each position of the armature, there is a definite output voltage, different in level and polarity than for any other position, no matter how slight the difference. The AC output may be demodulated, rectified, and filtered if a DC output signal is desired. Most commercially available LVDT transducers are DC input/output devices.

Special LVDT characteristics

90. Because of its special characteristics, the LVDT has distinct advantages over other devices used for motion mechanization of transducers. Some of these advantages follow:

- a. There is no significant friction or hysteresis, since there is no mechanical contact between windings and armature.
- b. There is no mechanical wear, hence virtually infinite life.
- c. Linear output assures accurate measurement with direct readout instruments.
- d. There is infinite resolution, limited only by the readout and control equipment.
- e. There is complete electrical isolation of output from input, permitting addition or subtraction of signals without buffer amplifiers.
- f. High level output simplifies circuitry.
- g. Overranging does not cause any damage or permanent change in characteristics.
- h. The LVDT is rugged, shock-resistant, and virtually maintenance free.

91. The piezoelectric principle is frequently used in transducers to translate dynamic force and motion into representative electrical signals. Certain materials, generally crystalline, have a physical property by which they produce an

electrical charge when stressed. The charge will "leak off" through the transducer's high internal impedance or an external load. Thus, this type of sensor is primarily used for measurement of dynamic phenomena. The sensitivity of piezoelectric sensors is generally high, requiring little or no amplification. Frequency response is excellent - typically flat to several MHz. Piezoelectric accelerometers, pressure transducers, and shock gages are inherently rugged and durable. However, because of their high internal impedance and dynamic characteristics, they generally require special "charge coupling" signal transmission and conditioning techniques.

92. Temperature is typically sensed and transduced to an electrical signal by thermocouple elements or resistance temperature devices (RTD). The operative principle of thermocouples is based on the the "Seebeck Effect", the junction of two dissimilar metals creates an electrical voltage potential which varies with the temperature to which the junction is subjected. Output voltages are in the millivolt range and vary nonlinearly with temperature. Table 2 identifies various thermocouple alloys with associated voltage polarity and the ANSI symbol for each.¹⁶

Table 2

ANSI Symbol and its Thermocouple Alloys

| <u>ANSI Symbol</u> | <u>Thermocouple Alloy</u> |
|--------------------|--|
| T | Copper (+) versus constantan(-) |
| E | Chromel(+), versus constantan(-) |
| J | Iron(+), versus constantan(-) |
| K | Chromel(+), versus alumel(-) |
| *G | Tungsten(+), versus tungsten 26% rhenium(-) |
| *C | Tungsten 5% rhenium(+), versus tungsten 26% rhenium(-) |
| R | Platinum(+), versus platinum 13% rhodium(-) |
| S | Platinum(+), versus platinum 10% rhodium(-) |
| B | Platinum 6% rhodium(+), versus platinum 30% rhodium(-) |

*These letters are not ANSI symbols

93. Each thermocouple type has specific capabilities. These are as follows:

- a. Iron constantan (ANSI symbol J)-The iron constantan "J"-curve thermocouple with a positive iron wire and a negative constantan wire is recommended for reducing atmospheres. The operating range for this alloy combination is up to 1600 °F for the largest wire sizes. Smaller size wires should operate in correspondingly lower temperatures.
- b. Copper-constantan (ANSI symbol T)-The copper constantan "T"-curve thermocouple with a positive copper wire and a negative constantan wire is recommended for use in mildly oxidizing and reducing atmospheres up to 750 °F. They are suitable for applications where moisture is present. This alloy is recommended for low-temperature work since the homogeneity of the component wires can be maintained better than other base-metal wires. Therefore, errors due to lack of homogeneity of wires in zones of temperature gradients are greatly reduced.

- c. Chromel-alumel (ANSI symbol K)-The chromel-alumel "K"-curve thermocouple with a positive chromel wire and a negative alumel wire is recommended for use in clean oxidizing atmospheres. The operating range for this alloy is up to 2300 °F for the largest wire sizes. Smaller wires should operate in correspondingly lower temperatures.
- d. Chromel-constantan (ANSI symbol E)-The chromel-constantan thermocouple may be used for temperatures up to 1600 °F in a vacuum or inert, mildly oxidizing, or reducing atmosphere. At subzero temperatures, the thermocouple is not subject to corrosion. This thermocouple has the highest electromotive force (EMF) output of any standard metallic thermocouple.
- e. Platinum-rhodium alloys (ANSI symbol S, R)-Two types of "noble-metal" thermocouples are in common use. They are: 1) a positive wire of 90% platinum and 10% rhodium used with a negative wire of pure platinum; and 2) a positive wire of 87% platinum and 13% rhodium used with a negative wire of pure platinum. These have a high resistance to oxidation and corrosion. However, hydrogen, carbon, and many metal vapors can contaminate a platinum-rhodium thermocouple. The recommended operating range for the platinum-rhodium alloys is up to 2800 °F, although temperatures as high as 3270 °F can be measured with the PT-30% Rh versus PT-6% Rh alloy combination.
- f. Tungsten-rhenium alloys (symbol 3 and 4)-Two types of tungsten-rhenium thermocouples are in common use for measuring temperatures up to 4000 °F. These alloys have inherently poor oxidation resistance and should be used in vacuum, hydrogen, or inert atmospheres.

94. When accurate thermocouple measurements are required, it is common practice to reference both legs to copper lead wire at the ice point so that copper leads may be connected to the EMF readout instrument. This procedure avoids the generation of thermal EMFs at the terminals of the readout instrument. Changes in reference-junction temperature influence the output signal, and practical instruments must be provided with a means to cancel this potential source of error. It may be accomplished by placing the reference junction in an ice-water bath at a constant 0 °C (32 °F). Because ice baths are often inconvenient to

maintain and not always practical, alternate methods are often employed, such as electrical self-compensating bridge networks. These commercially available devices reference thermocouple junctions to various temperatures (0°F , 150°F , etc.). Fundamentally, these networks generate a compensating voltage to cancel erroneous emf potentials at the "cold" or copper junction (T_2).¹⁷ (Figure 3).

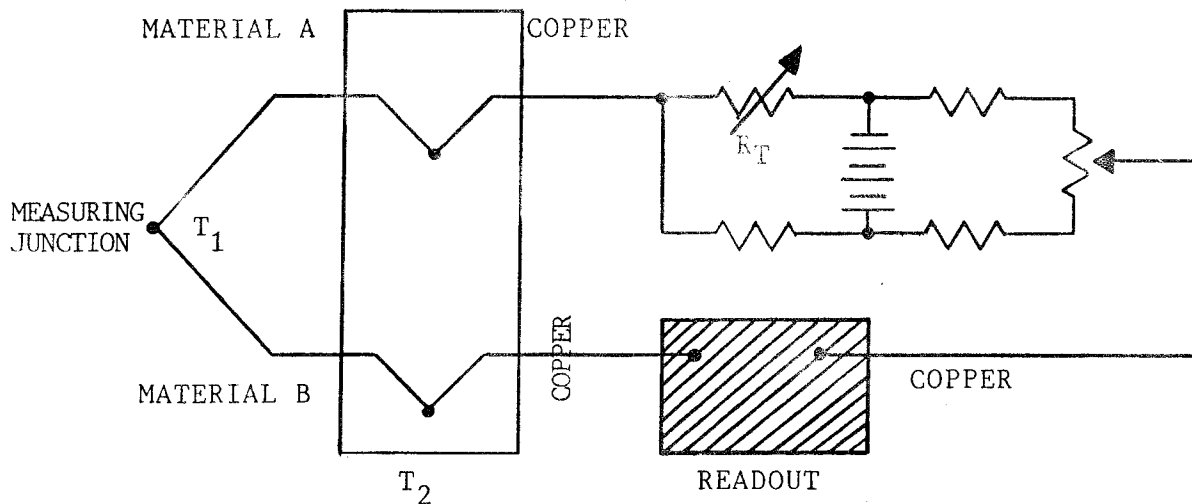

FIGURE 3. THERMOCOUPLE ELECTRICAL REFERENCE JUNCTION

95. Resistance temperature devices (RTDs) translate temperature variations to an electrically measurable quantity of resistance, i.e., the resistance of certain semiconductive materials (thermistor) and metal alloys varies with their temperature. The thermistor has a negative temperature coefficient. That is, as temperature increases, the resistance of the thermistor decreases. Most conductors of electricity such as copper wire have a positive temperature coefficient. These conductors increase in resistance as temperature increases. RTDs operate in temperature ranges from -400°F to $+1700^{\circ}\text{F}$. The RTDs are more efficient than other temperature sensors in that their response to temperature is more linear. A change in temperature provides an equivalent change in resistance over a broad range of temperatures. The best of the RTDs is the platinum RTD. It has become a world standard in laboratory form for measurement

between -270 °C and +660 °C. Precautions and compromises encountered in using other types of electrical temperature sensors are unnecessary. Ordinary copper wire is used to connect the sensor to the readout instrument. Since the calibration is absolute, cold-junction compensation is not necessary. The linear response eliminates corrective networks and errors in interpretation. Freedom from drift makes frequent recalibration unnecessary.

96. Other standards have been developed which are representative of the resistance values for RTDs at specific temperatures. Table 3 lists some of these worldwide industrial standard values.¹⁸

Table 3

Industrial Worldwide Standards of RTDs

| <u>Temperature (F) (in degrees)</u> | <u>Resistance (Ohms)</u> |
|-------------------------------------|--------------------------|
| 0 | 93.01 |
| 32 | 100.00 |
| 100 | 114.68 |
| 200 | 135.97 |
| 300 | 156.90 |
| 400 | 177.47 |
| 500 | 197.70 |
| 600 | 217.56 |
| 700 | 237.06 |
| 800 | 256.21 |
| 900 | 274.99 |

97. Because of its high electrical output, the RTD furnishes an accurate input to indicators, recorders, controllers, scanners, data loggers, and computers. Resistance changes in the RTD may be read directly with a precision ohmmeter or may be detected as a voltage change if the RTD is used as an active resistive element in a Wheatstone bridge application (see Figure 4).

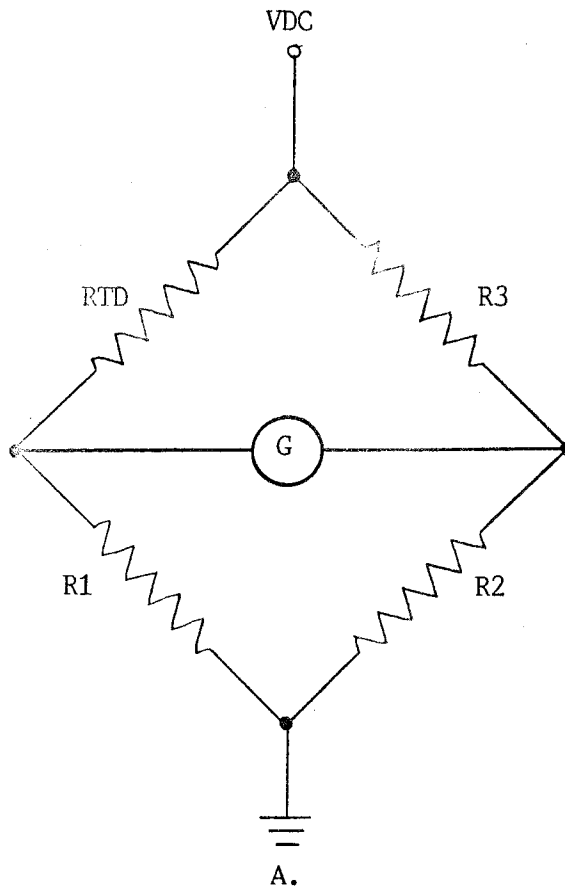

FIGURE 4. THE RTD IN APPLICATION

Transducer selection criteria

98. Although each physical phenomenon (example: tilt) and its corresponding measured parameter (example: angular displacement) have specific requirements associated with them, transducer selection criteria may be categorized into four general fields: 1) data requirements, 2) environmental requirements, 3) system considerations, and 4) economic factors. The System Requirements Document should clearly define data and environmental requirements relating to transducer selection. Table 4 lists general data, environmental and system criteria which must be considered in selecting a suitable transducer for a given application.

Table 4

Transducer Selection Criteria

| <u>Data Requirements</u> | <u>Environmental</u> | <u>System</u> |
|--------------------------|---------------------------------|-----------------------------|
| Range | Temperature compensation | Excitation |
| Overrange (limits) | Thermal zero shift | I/O impedance |
| Frequency response | Thermal sensitivity shift | Sensitivity |
| Linearity/hysteresis | Thermal shunt calibration shift | Gage factor |
| Residual unbalance | Static acceleration | Shunt calibration |
| Resolution | Vibration | Dimension, weight & size |
| Responsibility | Acoustic bombardment | Mounting |
| Total absolute accuracy | Altitude | Connector |
| | Humidity | Pressure or other connector |
| | Shock | Insulation resistance |
| | Thermal shock | Calibration |
| | Nuclear | Signal conditioning |
| | Electromagnetic | Reliability |
| | Material | |
| | Side axis response | |
| | Magnetic | |

96. There are several economic factors to be considered in selecting transducers. They are as follows:

- a. Accuracy: Specify only the required accuracy. This requires knowledge of actual system accuracy.

1. Special selection of a superior transducer adds to cost.
 2. Extra cost for documentation; i.e., calibration record.
 3. More expensive transmission lines are required for highest accuracy.
- b. Range: Choose a range which provides for a flexible application and an overrange which precludes damage to transducer.
 - c. Temperature compensation: Adds to the cost and should not be called out unless required.
 - d. Material: Must be compatible with media being sensed; however, a more exotic material than is required must not be specified.
 - e. Shock, vibration, acoustic bombardment, etc.: Can be minimized by remote location of transducer. For instance, a pressure of low frequency can be adequately monitored when the transducer is coupled to the chamber by isolation tubing. This permits selection of a less expensive transducer, simpler mounting, less expensive cabling (not high temperature), etc.
 - f. Electrical characteristics (sensitivity, impedance, excitation, etc.): These help to determine the cost of the remaining portions of the data system.
 - g. Physical characteristics (size, weight, mounting): These are economic factors. Miniature transducers generally cost more, weight may be a cost factor, and mounting fixtures generally require custom machining.
 - h. Connectors: If connectors are not included, the cost of a single connector may be as much as \$150.
 - i. Repairability: Repair charges are usually about 50% of the cost of a new transducer.
 - j. Reliability: Obvious.

Transducer hazards

100. As is the case with other electronic instrumentation, transducers and sensors are susceptible to damage and failure

when exposed or subjected to certain hazardous conditions. Some general and specific transducer hazards at COE sites include:

- a. Over excitation. Over excitation is one of the most common problems encountered with strain or temperature bridge probes. Excessive current simply melts the wires in the bridge causing it to "open", or at least alter the sensitivity, as well as linearity and hysteresis of the transducer. Over excitation can also damage variable transformers and similar transducers. Sources of over excitation are not limited to misadjusted power supply voltages, but can result from changes caused by line voltage variations, line transients, or on/off transients. Some power supplies produce up to +100% spikes when turned on. Proper excitation turn-on procedures, the use of zener diodes as DC voltage regulators, and metal-oxide varistors (MOV) as power supply AC-line transient suppressors will minimize the chance of over-excitation damage to transducers.
- b. Improper polarity of excitation. Some transducers do not provide protection for wrong power supply polarity; and when connected to the power supply in this manner, transducer damage may occur. A reasonable precaution for this problem is to connect a diode in series with the power leads to prevent current from flowing when polarized backward. Voltage must be monitored downstream from the diode to ensure correct excitation level on the transducer (see Figure 5).

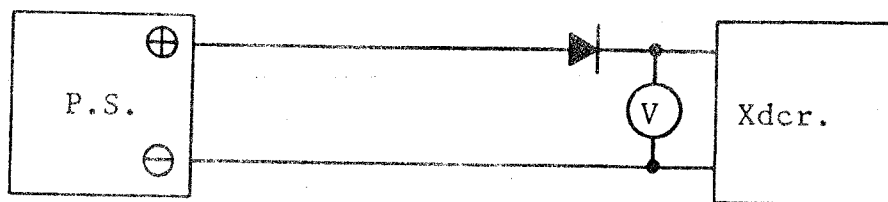

FIGURE 5. TRANSDUCER EXCITATION POLARITY PROTECTION

- c. Temperature effects. Extremely high temperatures can cause transducer damage. Examples of damage to various types are:

1. Piezoelectric devices - Artificial crystal materials lose their piezoelectric characteristics when raised to their Curie temperature, which is between 600 °F and 800 °F for most crystals. If a crystal is raised to a temperature near but not up to this Curie temperature, the transducer permanently loses some of its sensitivity. Natural quartz devices do not suffer this fate and for this reason are often used for high temperature work.
 2. Bonded strain gage transducers - The primary problem area is the destruction of the adhesive which is used to bond the strain gage to the diaphragm or beam. A temperature range from 200 °F to 400 °F usually destroys the adhesive.
 3. Unbonded strain gage transducers - The design of the unbonded strain gage device precludes many of the high temperature problems which are present with a bonded device. Temperatures up to 600 °F do not normally harm an unbonded transducer. There are rubber parts ("O" rings), solder joints, etc., which can be damaged in some unbonded devices not designed for high temperature work.
 4. Film strain gage transducers - The film gage can withstand temperatures up to the point of breakdown of the electrical connections. These connections are usually soldered so temperatures up to 300 °F are safe for most film gages.
 5. Other transducers - Most other transducers have a temperature limitation because of solder joints, "O" rings, etc., meaning avoidance of any temperatures above 250 °F is necessary.
- d. Shock. Shock is defined as, "An abrupt impact applied to a stationary object." It is usually expressed in gravities (g's). Any transducer may be damaged by shock. For this reason, some common sources of shock should be identified.
1. Shipping - Transducers are generally packed in specially designed containers which are intended to assure that shock levels are below the permissible maximum.
 2. Handling - Transducer handling represents a likely source of shock damage. A drop or bump may easily subject a transducer to a shock of several hundred g's.

3. Storage - Delicate transducers should be stored in compartments lined with shock-absorbent materials or in their original shipping containers.
4. Transducer installation - Transducers may be damaged by various practices during installation. Some of the more prevalent poor practices are:
 - o Applying excessive physical force or torque when mechanically mounting or electrically connecting the transducer.
 - o Installing a transducer to a test specimen before mechanical work is complete.
 - o Touching exposed sensing elements such as the diaphragm of a pressure transducer.
 - o Using improper tools and adapters to mount a transducer to a test specimen.
- e. System checkout and calibration. Transducers are sometimes damaged when a system checkout is being performed. To prevent exceeding the maximum physical input capability of the transducer, care must be taken when exercising the transducer and checking out the system for end-to-end response or calibration.
- f. Cleaning. Cleaning a transducer usually does not represent a serious hazard. It should only be cleaned with materials which do not harm the transducer. Also, mechanical abuse should be avoided while cleaning a transducer.

Signal Conditioning

101. Information or data in the form of low-level electrical signals generated by basic measuring transducers typically require manipulating or "conditioning" in some manner before they are presented to the automated system processor or recorder. Such signal conditioning functions may require specific devices for certain classes of sensors (strain gage bridge), or they may be essentially general purpose (filters) with application to a variety of signal transformations. Although certainly not exhaustive, the following types of signal

conditioning are often required and used in the design and implementation of measurement systems for COE applications.

Bridge circuits

102. The resistive strain gage and Wheatstone bridge network is used extensively as the transducing element in measurement systems. In normal operation, the bridge is excited by a constant voltage source and its output signal amplitude varies as the resistance of its branches changes. The bridge output is measured as the "differential" voltage across the bridge. Strain gage bridge applications require special signal conditioning techniques with elements of bridge excitation, bridge balance, bridge completion, and calibration (Figure 6).¹⁹

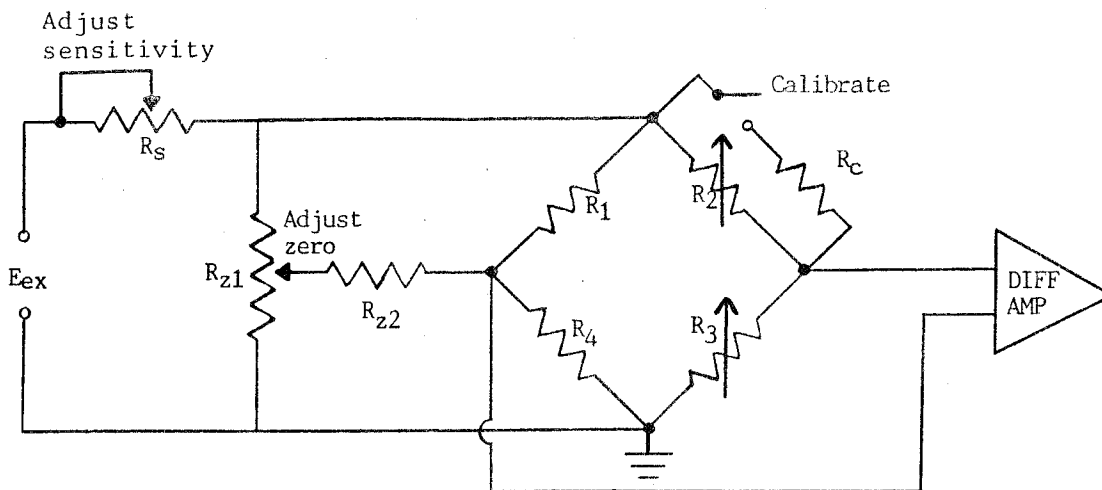

If $R_1 \approx R_2 \approx R_3 \approx R_4 < 1,000$ ohms (usual strain-gage transducer)

then $R_{z2} \approx 100 R_1$

$R_{z1} \approx 25,000$ ohms

FIGURE 6. BRIDGE WITH SENSITIVITY, BALANCE, AND CALIBRATION FEATURES

103. Bridge excitation supplies should generally be grounded and caution taken not to ground the output of the bridge. Output signals typically are applied to fully differential amplifier inputs of recorders, meters, or processor

systems. Bridge excitation, E_{ex} , must be a regulated constant voltage, but individual bridge sensitivities may be varied with the application of a series rheostat, R_s . This feature allows numerous bridges to be excited by one constant voltage source.

104. Bridge output signal is zero when the arm resistance ratio of the bridge is exactly matched. Connection of a balance potentiometer, R_{z1} and a series resistor R_{z2} , provides for adjusting the output voltage to be precisely zero when the measured physical quantity is zero, even if the arms of the bridge are not exactly matched. Resistor R_{z2} should be kept as high in value as practical, since it shunts the bridge and reduces its sensitivity somewhat. When one or two active arms are used, these arms should be opposite the R_{z2} side of the bridge.

105. Bridge completion resistors, R_1 and R_4 , may be required. If so, they should be soldered or connected via gold-plated contacts to prevent noise problems. Wire-wound resistors are recommended for resistance stabilities and repeatabilities of 1 part in 10^7 .

106. Strain gage bridges may be calibrated directly by introducing an accurately known resistance change, R_c "shunted" across R_2 , and recording the effect on the bridge output. One of the active arms is normally selected for shunt calibration. With the quality of today's instruments, a near full-scale bipolar shunt calibration is usually adequate to verify the system gain and that the full-scale transducer output isn't restricted by an undefined load. A FET switch may be used to connect the shunt resistor, R_c , to the bridge, but it should operate at the input or guard potential, and be optically isolated from ground.²⁰ Shunt calibration, bridge completion, or excitation voltage sensing over long lines requires that separate leads be used to

compensate for lead resistance errors. (Refer to paragraphs 7 and 8 in Appendix B).

Amplification

107. Measurements with electrical transducers and associated electronic instrumentation usually require amplifiers or related devices for signal conditioning functions such as buffering, isolation, gain, level translation, and current-to-voltage or voltage-to-current conversion. Most of these functions may be (and are) performed by operational amplifiers. However, the level and character of most transducer circuit techniques required for best design and implementation generally lead the prudent system designer to seek packaged, commercially available "system solutions", such as modular, multichannel DC instrumentation amplifiers.²¹ These instruments are characterized by excellent key amplifier specifications of input and output impedances, stability (drift), input bias current or offset current, gain (range, accuracy, linearity), and common-mode rejection. Bandwidth is critical in applications of high frequency dynamic signals such as seismic accelerometer outputs. Most commercial instrumentation amplifiers have selectable bandwidths from DC to 100kHz.

Instrumentation amplifiers

108. The ideal amplifier (not available) would be characterized by infinite common-mode rejection, input impedance, bandwidth and gain; and zero input offset, output impedance and drift. The commercial instrumentation amplifiers available today realistically approach this state. An instrumentation amplifier is a committed "gain block" that measures the difference between the voltages existing at its two input terminals, amplifies it by a precisely set gain, usually from 1 to 1000 V/V or more, and causes the result to appear between a pair of terminals in the output circuit. An ideal instrumentation amplifier responds only to the difference between the input voltages. If the input voltages are equal ($V^+ = V^- = V_{cm}$, the common-mode voltage), the

output of the ideal instrumentation amplifier is zero. The gain, G , is described by an equation that is specific to each model.

109. An amplifier circuit which is optimized for performance as an instrumentation-amplifier gain block has high input impedance, low offset and drift, low nonlinearity, stable gain, and low effective output impedance. Examples of applications which capitalize on these advantages include interfacing of thermocouples, strain gage bridges, current shunts, and biological probes; preamplification of small differential signals superimposed on large common-mode voltages; signal-conditioning and (moderate) isolation for data acquisition; and signal translation for differential and single-ended signals wherever the common "ground" is noisy or of questionable integrity.

110. Although all amplifier specifications are relevant and none should be neglected, the most-important specifications in transducer interfacing are those relating to gain (range, equation, linearity), offset, bias current, and common-mode rejection.

111. Gain range is defined as the range of gains for which performance is specified. Although specified at 1 to 1000, for example, a device may work at higher gain, but performance is not specified outside that range. In practice, noise and drift may make higher gains impractical for a given device.

112. Gain equation error or "gain accuracy" specifications describe the deviation from the gain equation when the gain-setting resistor is at its nominal value. The user may trim the gain or compensate for gain error elsewhere in the overall system. To take into account the lumped gain errors of all the stages in the analog portion of the system, from the transducer to the A/D converter, systems using digital processing may be made self-calibrating.

113. Nonlinearity is defined as the deviation from a straight line on the plot of output versus input. The magnitude of linearity error is the maximum deviation from a "best straight line", with the output swinging through its full-scale range expressed as a percentage of full-scale output range.

114. While initial voltage offset may be adjusted to zero, shifts in offset voltage with time and temperature introduce errors. Systems that involve "intelligent" processors can correct for offset errors in the whole measurement chain, but such applications are still relatively infrequent. In most applications, the instrumentation amplifier's contribution to system offset error must be considered.

115. Voltage offset and drift are functions of gain. The offset measured at the output is equal to a constant plus a term proportional to gain. For an amplifier with specified performance over the gain range from 1 to 1000, the constant offset is essentially the offset at unity gain, and the proportionality term (or slope) is equal to the change in output offset between $G = 1$ and $G = 1000$, divided by 999.

116. Input bias currents may be considered as sources of voltage offset (when multiplied by the source resistance). For balanced sources, the offset current, or difference between the bias currents, determines the bias-current contribution to error. Differences between the bias currents with temperature, common-mode level, and power supply voltage may lead to voltage offset or common-mode error.

117. Although instrumentation amplifiers have differential inputs, there must be a return path for the bias currents, however small. If the path is not provided, those currents charge stray capacitances, which cause the output to drift

uncontrollably or to saturate. Therefore, when amplifying the outputs of "floating" sources, such as transformers, thermocouples, and AC-coupled sources, there must be a DC "leak" from both inputs to common. If a DC return path is impractical, an isolator must be used.

118. In instrumentation amplifiers, common-mode rejection (CMR), is a measure of the change in output when both inputs are changed by equal amounts. CMR is usually specified for a full-range common-mode voltage (CMV) change, at a given frequency, and a specified imbalance of source impedance. The common-mode rejection ratio (CMRR) in instrumentation amplifiers is defined as the ratio of the signal gain, G , to the ratio of the common-mode signal appearing at the output to the input CMV. In logarithmic form, $CMR \text{ (in dB)} = 20 \log_{10} (\text{CMRR})$. Typical values of CMR in instrumentation amplifiers range from 70dB to 110dB. In the high-gain bridge amplifiers found in modular signal-conditioners, the minimum line-frequency common-mode rejection is of the order of 140dB.²²

Isolation amplifiers

119. The isolation amplifier, or isolator, has an input circuit that is galvanically isolated from the power supply and the output circuit. Isolators are intended for: applications requiring safe, accurate measurement of DC and low-frequency voltage or current in the presence of high common-mode voltage (to thousands of volts) with high common-mode rejection; line-receiving of signals transmitted at high impedance in noisy environments; and for safety in general-purpose measurements where DC and line-frequency leakage must be maintained at levels well below certain mandated minimums. Principal applications are in electrical environments of the kind associated with dams and large concrete structures, conventional and nuclear power plants, automatic test equipment, industrial process-control systems, and field-portable instrumentation.

120. In concept, any nonconducting medium may be used for isolation, including light, ultrasonics, and radio waves. But due to its low cost and (relatively) easy implementation, the medium that is currently in widest use is transformer-coupling of a high-frequency carrier for communicating power to and signals from the input circuit. Because of the transformer coupling, the output of these devices is isolated from the input stage.

121. One of the most important considerations about using an isolation amplifier is the manner in which it is hooked up. The following guidelines, if observed, may help a user to realize the full performance capability of the isolator and minimize spurious noise and pickup. Since the more common sources of electrical noise arise from ground loops, electrostatic coupling, and electromagnetic pickup, these guidelines concern the guarding of low level millivolt signals in hostile environments.

- a. Use twisted shielded cable to reduce inductive and capacitive pickup.
- b. Where possible, drive the transducer cable shield, S , with the common-mode signal source, E_G , to reduce the effective cable capacitance, as shown in Figure 7. This is accomplished by connecting to the signal low point, B , wherever possible. In some cases, for example, the shield must be separated from signal low by a portion of the medium being measured, causing a common-mode signal, E_M , to appear between the shield and signal low. The CMR capability between the input terminals (HI IN and LO IN) and GUARD work to suppress that common-mode signal, E_M .
- c. To avoid ground loops and excessive hum, signal low, B , or the transducer cable shield, S , should never be grounded at more than one point.
- d. Dress unshielded leads short at the connection terminals and reduce the area formed by these leads to minimize inductive pickup (Figure 7).

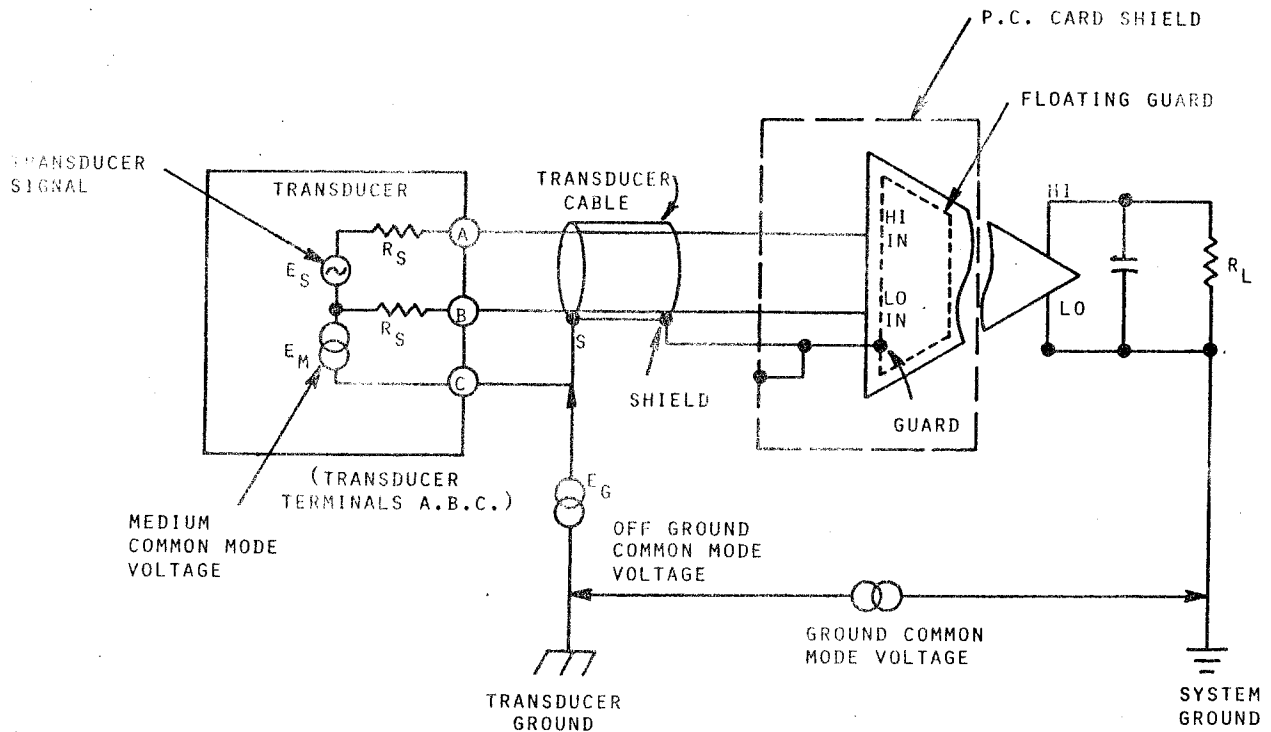

FIGURE 7. TRANSDUCER-AMPLIFIER INTERCONNECTION

Filtering

122. Conditioning analog signals with filtering is a method of attenuating or eliminating electrical signals of undesired frequencies, i.e., the systems engineer may select the analog data passband with passive or active filter networks commonly found in commercial instrumentation. The four basic types of filters are: 1) low-pass, 2) high-pass, 3) band-pass, and 4) notch, named for their frequency discrimination/response characteristics.

123. The low-pass filter is commonly used in low frequency data applications to eliminate signal noise that originates at the signal source or is picked up in data transmission. The low-

pass filter also serves to prevent aliasing errors. It passes low frequency data signals with little attenuation and has a large amplitude attenuation at high frequencies. The rate of attenuation, roll off, is determined by the "order" of the filter. A second-order filter has a faster roll off than a first-order filter, etc. For any type filter, the "cut off" frequency is defined as the frequency at which the filter attenuates the signal amplitude by 3 db from its maximum value. Frequently, in commercial filters, the cut off frequency may be variable and switch-selectable by the user. The majority of structural measurements made by the COE result in very low frequency data signals which can be low-pass filtered to increase signal-to-noise ratio and enhance accuracy. It is highly desirable to select a cut off frequency as low as possible for the sensor signal conditioning. A good guideline is to select a cut off frequency which is as low as the desired information from the transducer will permit.

124. High-pass filters characteristically pass high frequency signals and attenuate low frequency signals. Typically, high-pass filtering may be used in piezoelectric accelerometer measurements of seismic activity to minimize errors due to amplifier bias currents and high noise gain at low frequencies in charge amplifiers.²³

125. A band-pass filter is typically formed by cascading a low-pass and a high-pass filter of appropriate cut off frequencies to obtain the desired band-pass characteristics. This type of filter finds a primary use in signal conditioning of low to moderately high frequencies, low level dynamic signals having a DC component that is of no interest. The DC is blocked and high frequency noise is reduced by a band-pass filter application.

126. A notch filter is characterized by attenuating or "notching out" a narrow frequency band of an electrical signal. A common use of the notch filter is the rejection or elimination of 60-Hz power line interference in analog data signals.

Signal conversion

127. The two primary forms of electrical signals used in data transmission are analog and digital. In analog signals, information is contained in the varying amplitude and/or frequency of voltage/current. On the other hand, digital electrical signals present information in the form of coded, two-level voltage pulses. The presence (logic 1) or absence (logic 0) of a pulse digitally encodes data in serial or parallel formats for use in computer or digitally based systems. Frequently, it is necessary to convert electrical signals from one form to another in large instrumentation and data acquisition systems. Signal conversions in these applications are generally of four basic types: 1) analog-to-digital, 2) digital-to-analog, 3) voltage-to-frequency, and 4) frequency-to-voltage.

128. The analog-to-digital converter (ADC) is the most widely used signal converter today. As the name implies, this device converts or "digitizes" analog signals to a digital form for further processing or display. Important parameters and specifications for ADCs are conversion time, accuracy, and linearity. Two types of ADCs generally used in data acquisition systems are successive-approximation and integration.

129. Successive-approximation ADCs are quite widely used, especially for interfacing with computers, because they are capable of both high resolution and high speed. Conversion time is fixed and independent of the magnitude of the input voltage. Each conversion is unique and independent of the results of previous conversions, because the internal logic is cleared at the start of each conversion. Since the accuracy of this type of

ADC is dependent upon the input not changing during the conversion process, a "sample-hold" device is usually employed ahead of the converter to retain the starting input value.

130. The integrating ADC is also quite popular. It performs an indirect conversion, by first converting to a function of time, then converting from the time function to a digital number using a counter. The dual-slope type is especially suitable for use in digital voltmeters and those applications in which a relatively lengthy time may be taken for conversion to obtain the benefits of noise reduction through signal averaging. Though too slow for fast data acquisition, dual-slope converters are quite adequate for such transducers as thermocouples and gas chromatographs. They are the predominant circuit used in constructing digital voltmeters.²⁴

131. The digital-to-analog converter (DAC) is used to convert digitally formatted signals to analog voltages or currents. A DAC consists of a binary-weighted network whose outputs are summed to produce an analog signal that is proportional to the binary or digital input (Figure 8). Inputs to the weighting network are controlled by solid-state switches that convert the digital signal to the proper binary form. The output of a DAC can be either current or voltage.²⁵ Typical applications of a DAC include programmable power supplies, current sources, pulse generators, panel meters, and industrial process control.

132. Voltage-to-frequency and frequency-to-voltage conversion is a process of transforming electronic data signals from the analog domain to the time domain and vice-versa. Voltage-to-frequency converters (VFC) convert analog voltage or current levels to pulse trains or other repetitive waveforms at frequencies that are accurately proportional to the analog quantity. The output frequency continuously tracks the input

signal, responding directly to an input level change. Salient specifications for VFCs include linearity as a percent of full-scale frequency, and frequency range in hertz (the higher the frequency range the better the resolution). Typical applications for VFCs include FM modulation, frequency-shift keying, A/D conversion with high resolution, two-wire high-noise-immunity digital transmission, and digital voltmeters.

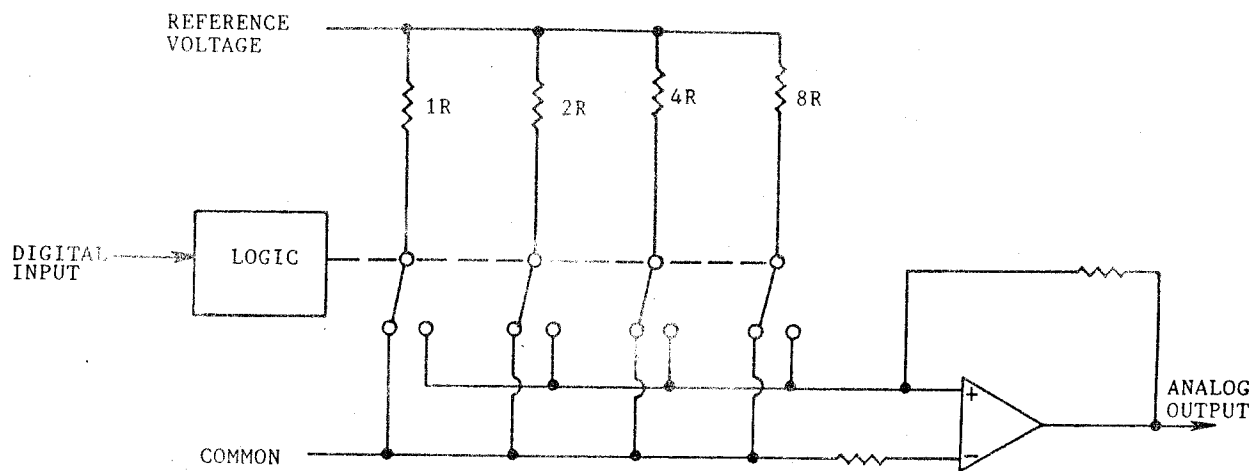

FIGURE 8. TYPICAL DIGITAL-TO-ANALOG NETWORK

133. Frequency-to-voltage converters (FVC) perform the inverse operation of the VFC; they accept a variety of periodic waveforms and produce an analog output proportional to frequency of the input waveform. Within the device, FV conversion is usually accomplished by integrating current pulses that occur repetitively at the frequency of the input. The resulting average value current is proportional to the input frequency and may be further converted into a proportional voltage. In addition to those stated above for VFCs, important FVC specifications include "output ripple", threshold, hysteresis, and dynamic response. Frequency-to-voltage applications include programmable frequency switches in instrumentation, motor speed control, and voltage controlled oscillator (VCO) stabilization. In analog-to-analog data transmission, the FVC converts serially transmitted data-pulse streams back to analog voltages.

Electrical interferences

134. Low level instrumentation signals are very susceptible to any number of electrical interferences. Such interferences may generate spurious, error-producing voltages that are orders-of-magnitude larger than the actual measuring sensor output. Electrostatic, electromagnetic, and RF-source interferences are frequently encountered in instrumentation applications. They require special conditioning and shielding techniques to minimize their effects on system measurement accuracy.

135. Electrostatic interference is a function of potential difference between two points, conductors, etc. Any path, intentional (wire) or unintentional (self- and mutual-capacitance leakage), between these potential differences carries current and produces voltages. To minimize unwanted electrostatic signals, special shielding techniques and procedures such as the following are applied:

- a. Enclose low level signal carrying components in metal-shielded containers whenever possible and ground the container to earth or zero signal reference potential.
- b. Ground or connect shields at only one point in the general path of signal flow. Because of ground potential differences, a signal shield cannot have multiple connections to a ground if it is to function as an electrostatic guard. Two or more shield ties force a voltage gradient along the shield. A proper shield must be at one potential along its entire length.²⁶

136. Potential differences in grounds generally produce current flows that in turn create common-mode signals.

137. The circuit in Figure 9 is designed to reject common-mode signals defined as voltage E. This voltage is a common-mode signal because it is impressed in "common" on both input leads.

The signal, E_S , is a differential-mode signal, for the amplifier responds to this "difference" signal. Frequently, this signal is called a normal-mode signal.

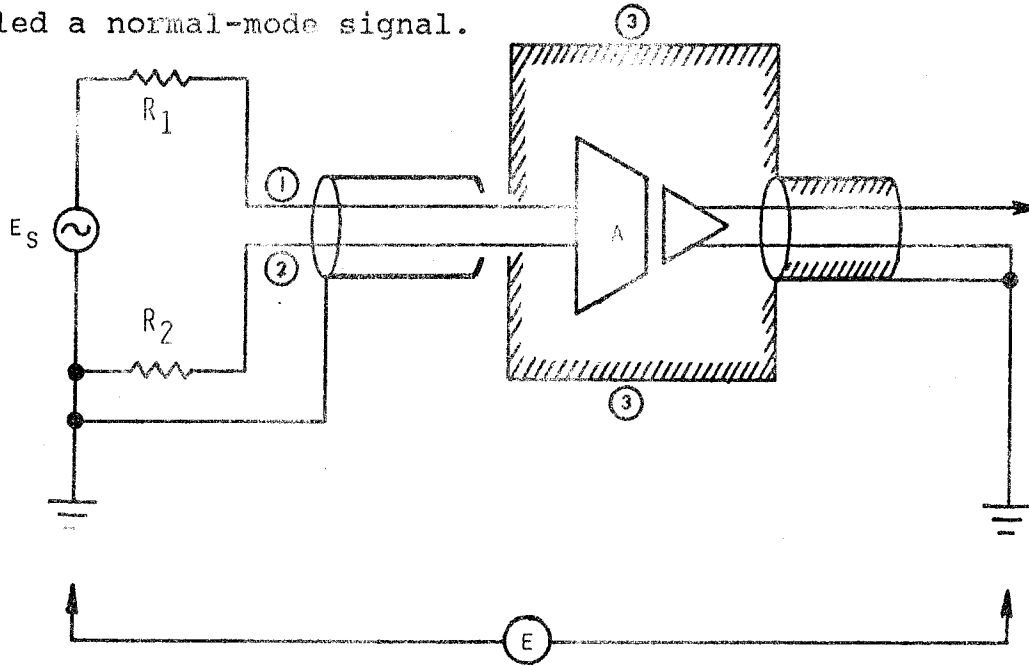

FIGURE 9. A SINGLE AMPLIFIER TO REJECT SIGNAL E

138. A second type of common-mode signal frequently encountered in instrumentation is the excitation voltage used in a strain gage bridge. If one corner of the bridge is grounded, then one-half of the excitation is common-mode and must be rejected. This circuitry is shown in Figure 10.

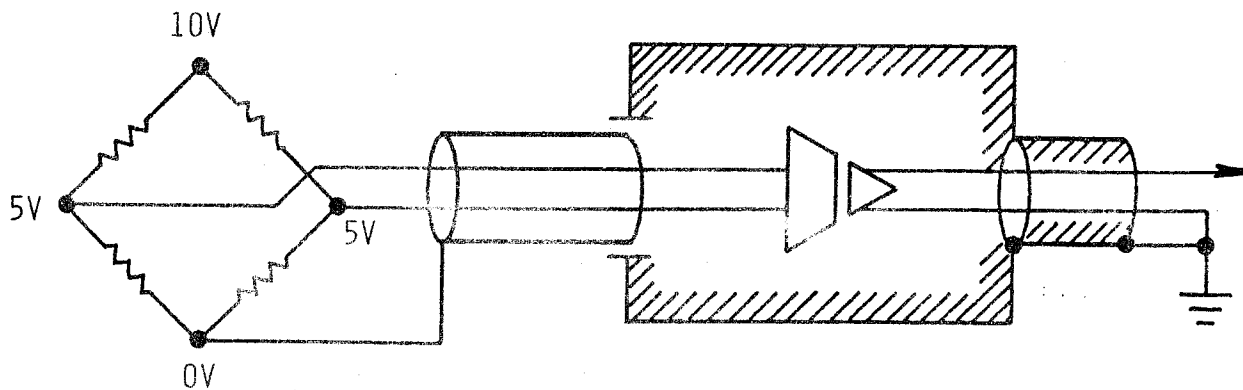

FIGURE 10. EXCITATION VOLTAGE AS A COMMON-MODE SIGNAL

139. Instrumentation amplifiers are widely used to reject unwanted common-mode signals in data systems. A common-mode signal for an instrument amplifier is defined as the average input signal or:

$$E_{CM} = 1/2 (E_1 + E_2)$$

and the differential-mode signal is defined as the difference voltage or:

$$E_{DM} = E_2 - E_1$$

Note that if $E_1 = 0$, the difference signal is E_2 and the common-mode signal is $1/2 E_2$.

140. The low frequency interference problems in instrumentation generally involve electrostatic fields. When these fields change and currents flow, these currents create magnetic fields. Changing magnetic fields, in turn, results in electromagnetic radiation which induces stray currents and voltages in nearby conductors and circuits. At RF frequencies, even small capacitances appear as low reactances. For example, 100 pF is 150 ohms at 10 MHz. This means that nearly every conductor associated with a rack of instrumentation forms a ground loop with the ground plane and numerous other conductors. No pair of conductors is immune. Ground neutrals, commons, shields, power lines, control lines, and signal lines all form loops.

141. Typical RF sources are radio, television, and radar sites. Also present are such devices as diathermy machines, arc welding, fluorescent lights, and glow lamps. These latter devices radiate a wide spectrum of noise. Another class of radiated energy stems from transient phenomena caused by contact arcing, surge or inrush current, step loads, etc. Proper system grounding and shielding techniques preclude effects of RF interference. Paragraphs 64-67, 121, and 135 of this report discuss these techniques.

Data Transmission

142. The two basic types of data transmission are: cable transmission and radio transmission. When choosing a method of transmission, the three most important factors are distance, frequency, and environment. Generally, a short-distance, low frequency link in an environment that has little or no electrical interference is the least expensive. Physical environment (moisture, extreme temperatures, etc.) can also play a role in increasing cost. The data may be transmitted as an analog or digital signal. Digital methods of transmission tend to be less subject to interference and have the advantage of error codes to verify data integrity. The disadvantage of using digital methods is the requirement of digitizing the signal at the source. This requires that a power source and individual analog-to-digital converters be located at the sensor end of the data link. Individual converters are more expensive than multi-channel systems on a per channel basis. Low level analog voltage signals are the most subject to interference. Most analog signals are transmitted as a voltage level over short distances, but also are transmitted over the widely used 4-20 mA current loop. This two-wire system is intrinsically safe because the low current does not permit a spark, even if a short circuit occurs in the leads. Because the system operates from 4 to 20 mA rather than 0 to 20 mA, the presence of a 4-mA current confirms link connection. Data may also be digitally transmitted in parallel or serial. Parallel is the faster and more costly method of transmission because of the number of channels required. Radio transmission is generally more costly for short links. The cost of signal amplifiers, cable, and cable installation should be weighed against the cost of the radio transmitter, receiver, and antennas.

Multiplexing

143. Multiplexing is the sending of two or more separate signals over the same channel.²⁷ The two main forms of multiplexing are time-division and frequency-division. In time-division multiplexing, a serial link is divided into segments of time for a digital word or analog signal. A synchronization or start pulse is commonly used to assure that the receiver-demultiplexer reads the signal at the proper time. Frequency-division multiplexing is accomplished by translating each signal into a frequency band which is different from any other frequency band being transmitted over the link. Usually all frequency bands are used to modulate a carrier frequency for transmission. Several hundred signals can be transmitted in parallel over the same channel using this method. Multiplexing can drastically reduce signal conditioning, cabling requirements, the number of receivers, the number of transducers, and installation time (Figure 11).

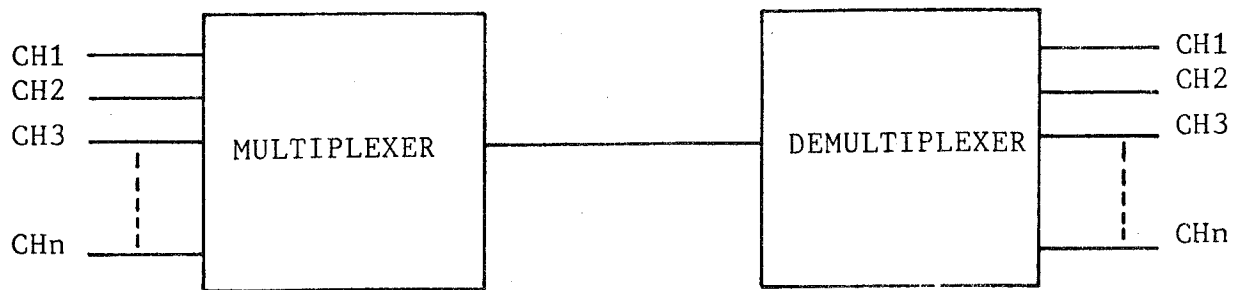

FIGURE 11. TYPICAL MULTIPLEXED LINK

144. The disadvantages of multiplexing are mainly the requirement for power at the transmitter end, the cost and maintenance of the electronics for the transmitter and receiver. When using time-division multiplexing, the serial link can slow the throughput.

145. There is a method of multiplexing which is used for random sampling of signals. This method requires two-way communication on the link. The receiving system sends an address of the signal of interest and the transmitting multiplexer returns the signal or data requested.

146. The main advantage of multiplexing is that it reduces system hardware redundancy.

System Configurations

147. When designing a data transmission scheme, there are several choices of configuration. The three most common network configurations are centralized (star), loop (ring), and distributed. These configurations are designed for intelligent controllers at each end (such as terminals, multiplexers, data loggers, etc.), and not for single lines such as signals from transducers, meters, etc. In a centralized system, data lines are connected to a central point where a controller handles message routing, speed conversion, code or protocol conversion, and error checking (Figure 12). The advantages of a centralized network are simplification of network control and individually shared control hardware and software by all hosts on the network. The main disadvantage of a centralized structure is that lines apply to one host and cannot be simultaneously shared with others. Alternate routing of messages may only be achieved by redundant links between the central node and remote hosts.

148. In a loop configuration, the interfaces are serially linked in a circular manner (Figure 13). Loop configuration works well in a network in which remote controllers are relatively close to each other, such as within one city. Communications interfaces are less costly for this configuration. However, they require high-speed data communications links.

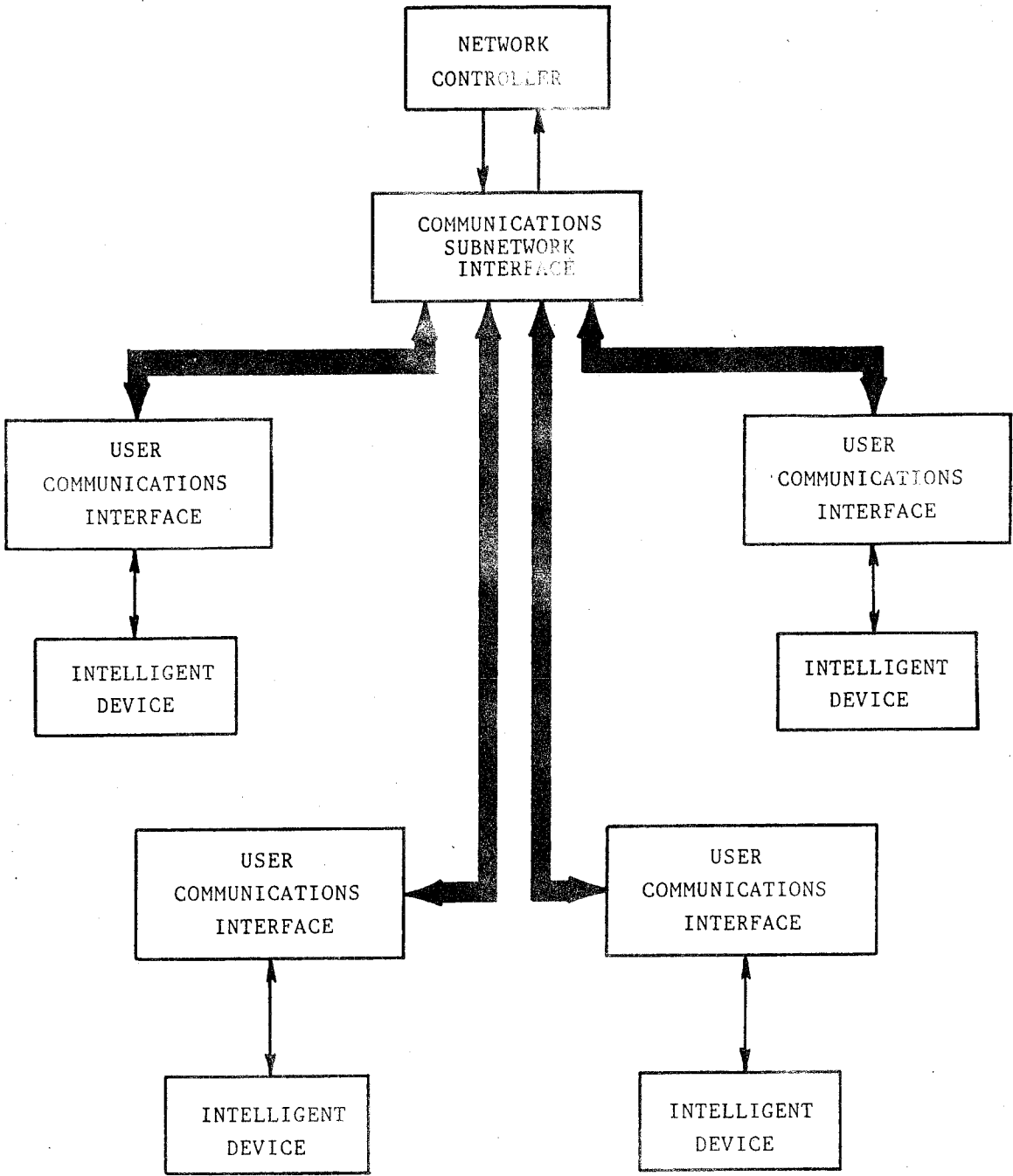

FIGURE 12. STAR CONFIGURATION

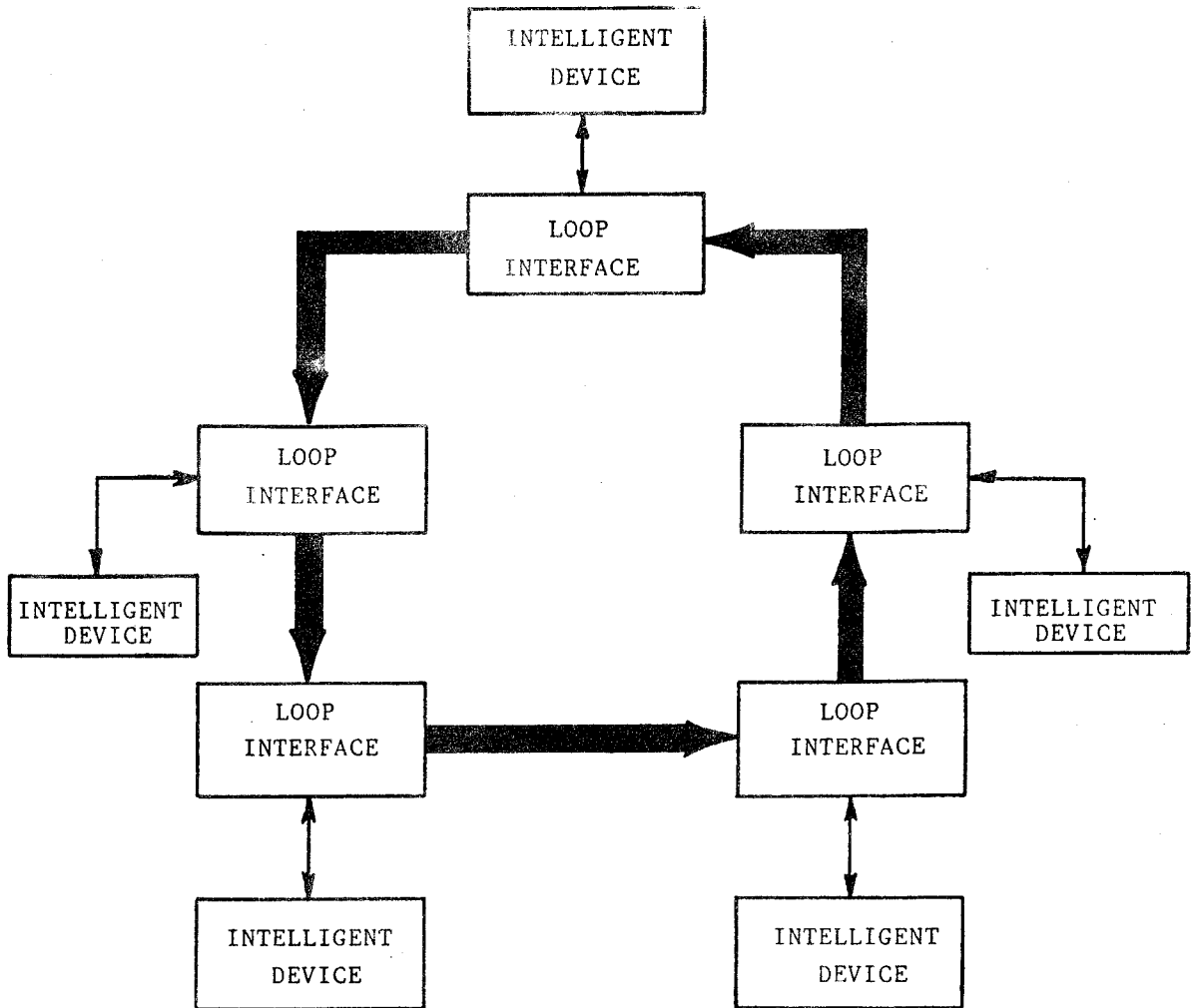

FIGURE 13. LOOP CONFIGURATION

149. In a distributed network configuration, intercommunications may be achieved by any node pair in the network (see Figure 14). The advantage of a distributed network is that a failure at one node does not affect the rest of the network. The disadvantages of distributed networks are that they are difficult to control and require complex communications network interfaces at each node.

150. If more than one central processing unit is connected to a network, the network may be used for remote job entry, remote batch processing, interactive processing, dynamic file access/transfer, and load sharing.²⁸

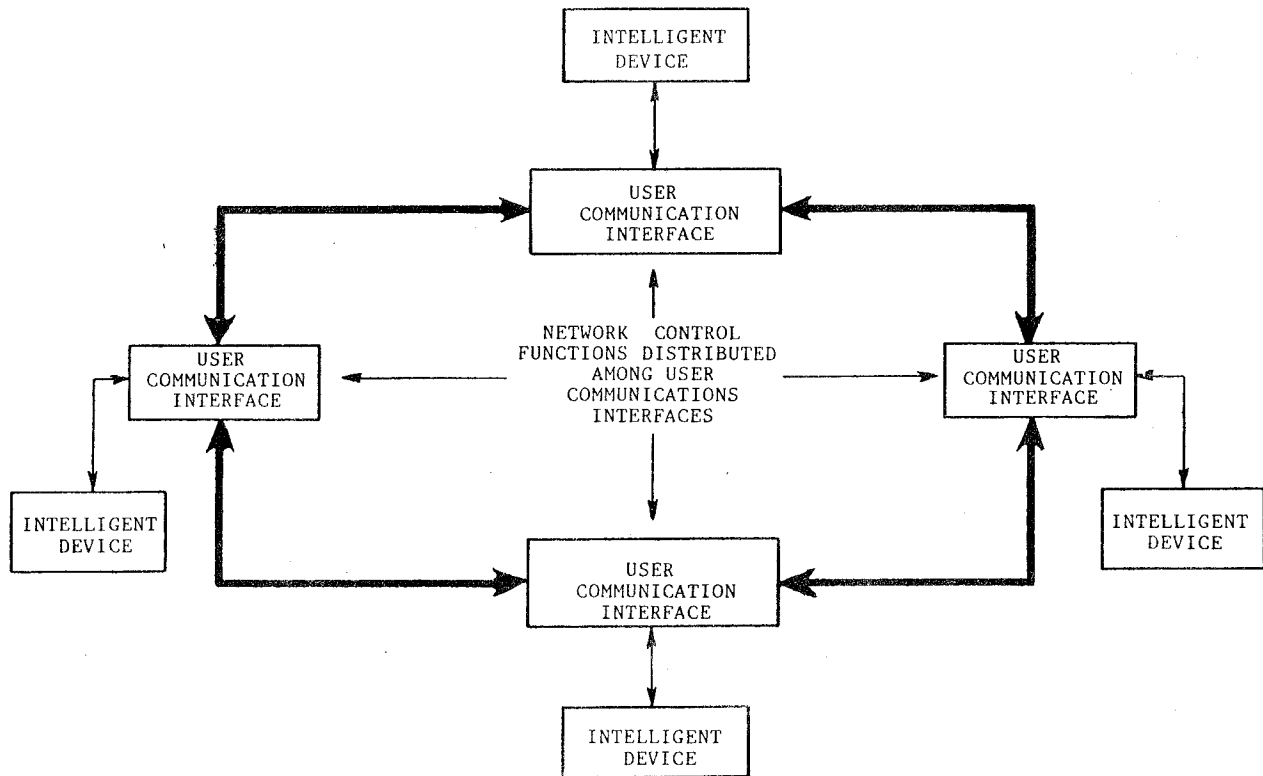

FIGURE 14. DISTRIBUTED CONFIGURATION

151. Networks may be connected to phone lines through modems and linked anywhere the phone lines go. Networks may be

routed through switching systems which allow interconnection between remote sites. Some switching systems employ a "store and forward" scheme. Here, if a message is bound for a line which is being used, it is stored until the line is free and then transmitted. To increase line throughput and save on common carrier charges, data concentrators are used. Data concentrators can perform multiplexing, but the value of a data concentrator lies in its ability to create a compact signal for direct connection to a high-speed computer port.²⁹ This is accomplished by packing two digits into one byte, substituting a unique byte for several spaces, assembling low-speed bits into character blocks, performing code and baud rate conversions, and employing various other methods of recreating redundant data.

Transmission techniques

152. The most common and inexpensive method of transmission for short (one kilometer or less) links is electrical cable. As the frequency increases so that the distance becomes an appreciable fraction of the wavelength of the signal being propagated, the interconnecting wires can no longer be considered short circuits.³⁰ Length, diameter and geometrical layout become significant at higher frequencies. Factors which should be considered on high frequency lines are characteristic impedance, losses due to radiation, losses due to reflected power, and signal attenuation. Two types of commonly used cables are parallel wire and coaxial. Parallel wire cables are used for low-to-midfrequency and balanced line applications. Using twisted pair (signal and return) and/or an outer conductive shield reduces noise and interference. Coaxial cable is used for frequencies up to 18 GHz in unbalanced line applications. Signals may be transmitted over cables in single-ended or differential modes. In the single-ended mode, the signal return is referenced to a ground. In the differential mode, the return is allowed to float, and the receiver detects the difference between signal and return. The differential mode has better

noise immunity and common mode rejection than the single-ended mode. Analog or digital signals may be transmitted in either mode. Analog signals tend to be corrupted by the response characteristics of the transmission line and noise from various sources. Even severe degradation of pulse shape by the transmission medium and noise does not affect the accuracy of a digital transmission as long as the presence or absence of a pulse can be detected.³¹ Digital transmission systems also have the advantage of error detection and/or correction.

153. When noise and interference become intolerable, a fiber-optic link may be used. Fiber-optic links also provide electrical isolation. These are very high-speed links and have a wide bandwidth.

154. When interconnecting cables are not possible or desirable, signals may be transmitted by radio. Radiotelemetry consists of performing measurements on distant objects and transmitting signals via radio. There are several forms of radiotelemetry which employ time-division multiplexing, frequency-division multiplexing, or combinations of the two. Signals may be amplitude or frequency modulated and may be analog or digital. Pulse modulation is also used. According to the Federal Communications Commission (FCC) and international regulations and agreements, the frequency bands allocated to the radiotelemetry range are from 216 to 220 MHz and from 2.2 to 2.3 GHz. The alternatives to radiotelemetry are either having observers on the spot or having some form of multitrack recorders on the site from which data may be collected when convenient. Since radiotelemetry can become quite complex with problems associated with transmitters, antenna location and orientation, and noise interference, other forms of data transmission should be investigated first.

155. One of the most recent innovations in data transfer is the use of satellites to transfer information from one spot in the country to another. The transfer can take place using one of the government or commercial satellites which remain stationary over one geographical location of the country. For the purposes of transmission of Civil Engineering data via satellite, the use of the GOES (Geostationary Operational Environmental Satellite) satellite has proven very successful in the past. Data is transmitted from the site to the satellite via a radio transmitter. The data is then transferred to a ground receiving station where it can be further reduced and used for monitoring the remote operations.

156. The equipment that is necessary to accomplish this transfer is called a data collection platform. It consists of a data collection unit, usually of an intelligent nature capable of making decisions under the control of a computer program, a transmitter, and a transmitting antenna. With the use of this equipment, data can be transmitted from one side of the country to the other instantly, and stored in a computer at the receiving site.

Data transmission interval

157. When choosing a transmission method, a major consideration is how often the data or signals need to be read. For a remote site, where data are gathered once a year, transmission could be via a site visit to pick up a strip chart, magnetic tape, or other data medium. If the data are gathered hourly, the site visit would become a full-time job for one person. In cable and radio transmission, a comparatively slow transmission requires a less complex and costly system than a high-speed transmission. How often the data or signals are read and how long it takes to read them should be considered in system design.

Transfer rate (resolution and accuracy)

158. Transfer rate, sometimes referred to as throughput, is the number of readings or signals which can be transferred per unit of time (usually per second). If a system has a 10-k throughput, then it is capable of 10,000 readings per second. If a serial digital transmission is used and has a 10-k throughput with a 16-bit resolution, the transmission line must be able to support more than 160 kbaud (adding control, error, and synchronization bits). An analog system must be able to support a bandwidth greater than the highest frequency used. Transfer rate is a controlling factor in the selection of a transmission method and usually has a direct relationship to cost. Resolution influences the selection of a transmission method because higher resolution requires additional data transfer rates. Consequently, resolution directly influences costs.

Data bandwidth

159. Data bandwidth is the range of frequencies from the highest to the lowest required to transmit the data. If the data are sinusoidal, the bandwidth is simple to calculate. If a carrier frequency is used, the bandwidth is the difference between the highest frequency (carrier frequency plus the highest modulating frequency) and lowest frequency (carrier frequency minus the highest modulating frequency). If the data are nonsinusoidal, the bandwidth is more complex to calculate. Since the square wave is the most common method of digital data transmission, its bandwidth characteristics should be considered. All waveforms are comprised of sine and/or cosine waves. The fundamental (or lowest) frequency of a repetitive waveform is equal to its repetition rate. Different harmonics of the fundamental frequency combine to give the waveform its shape. There are an infinite number of such harmonics.³² In the case of a square wave, the odd harmonics combine to form the wave shape. The higher the harmonic, the lower its relative amplitude, so that in bandwidth calculations higher harmonics are often

ignored. The bandwidth of a transmission line or component should be sufficient to achieve the same wave shape at the receiving end as at the transmitting end. As the bandwidth narrows or drifts up or down, the wave shape at the receiving end distorts. Low frequency distortion appears as a sag in the square wave center; high frequency distortion appears as a rounding of the square edges.

Data Processing, Display, and Recording

160. Data processing, display, and recording functions range from simple systems to very complex software-intensive computer systems. An example of a simple system is a strip chart recorder. The data signal is conditioned, displayed and recorded in a single unit. The disadvantage of this system is that the output data are not in a form which may be easily interpreted or entered into a system for reduction or evaluation. Most low end systems supply raw data or data in a form which may not be used in other systems. Computer systems give the highest degree of flexibility for data processing, manipulation, display, recording, and storage.

Data processing

161. The vast majority of data processing is digital processing; analog processing is rare. Once the signal is digitized by the the "front end", it is input to the computer or data system as raw data.

162. At this point, the data volume is at its maximum. The raw data may be stored and/or recorded at this point for conversion, reduction, or analysis; or they may be processed as they are being read, depending upon the speed required. If the raw data are stored and then processed, this is called batch processing. If the data are processed as they are read, this is called real-time processing.

163. The first step in processing raw data is usually to convert the data to engineering units. In this conversion process, calibration factors are often used to compensate for inaccuracies. The speed and flexibility of this process are influenced by the computer language used, as are all computer functions. Once the data have been converted to the proper units, they are usually stored on some medium for later reduction or analysis.

164. All computer languages have advantages and disadvantages. Choosing the best language for a particular application should be the job of a software expert. The following is only a quick overview for basic understanding. A more thorough discussion may be found in the report on "Available Data Collection and Reduction Software".

165. The lowest level language to which all languages are eventually converted is machine code. Machine code is machine dependent or unique to each type of machine. Machine code consists of binary words made up of ones and zeros which are interpreted as instructions by the machine, and is extremely difficult to interpret.

166. The next level of language is called ASSEMBLY language and consists of acronyms which represent machine functions (add, move, etc.). ASSEMBLY language is the fastest running language, but it is cumbersome and difficult to interpret.

167. The BASIC language is a higher level of language. However, BASIC is very slow running. The most frequently used high level languages are COBOL, FORTRAN, and Pascal. COBOL is a business language designed to handle large amounts of data with very little manipulation.

168. FORTRAN is a scientific language designed to handle small amounts of data with a great deal of manipulation. Pascal is designed to be a fast running language with some of the advantages of both COBOL and FORTRAN.

Data manipulation

169. After the raw data have been converted to usable units and stored, they are still in a form which is difficult to interpret. Now the computer system goes to work. An intermediate stage may be to put the data into an array according to some parameter for use, sort the data by some parameter, or scan the data for significant events. Data reduction is an important step for discarding meaningless data or combining useful data into a time-history presentation. Trends plotting is another form of data reduction. Once the meaningful information is deciphered and stored, it must be put into a humanly interpretable form. The software and hardware combine to prepare the data for output to a device such as a printer, plotter, etc.

Display

170. The most common types of data display are as follows:

- a. Printers: Line printers
Character printers
Letter quality printers
Dot matrix printers
Daisy wheel printers
Electrostatic printers
- b. Plotters: Flat bed plotters
Moving paper plotters
Multipen plotters
Electrostatic plotters
- c. Cathode Ray Tubes:
Monochrome
Color
High resolution

d. Alphanumeric Displays:

Light emitting diodes (LED)
Liquid crystal displays (LCD)
Gas discharge displays
Dot matrix displays

Recording/storage

171. Recording and storage deal with data that are in a form for use within the computer and are not easily interpreted. The random access memory (RAM) of the system is generally for transient data and is not for long term storage. One of the best and least expensive methods for storing large amounts of data is magnetic tape. The biggest disadvantage of magnetic tape is that it is a sequential storage method. If the data required are at the end of the tape, an operator must search all data to arrive at the desired data. Magnetic disk storage is random access storage, which lends itself to faster and more flexible data retrieval and manipulation. Magnetic disk costs more per unit of storage area than tape. In large systems, data are recorded on magnetic tape for storage and transferred to magnetic disk for processing. The two commonly used types of magnetic disks are hard disks and floppy disks. The more reliable and more costly is the hard disk. Hard disks may be fixed or removable, and are generally restricted to use on one particular model of disk drive. Floppy disks come in a variety of sizes and are sometimes transportable between devices if the format, number of tracks, and density are matched. Magnetic tape is also transportable between systems if the format, density, and size are matched.

172. Although magnetic tape and disk are the most commonly used methods of data recording and storage, other methods are available. These include punched cards, paper tape, and bubble memory. All of these methods are sequential and have advantages for specific applications. Strip charts may also be used for recording and data entry into a system. However, the recorder output must be digitized and which constitutes a slow process.

PART IV: SYSTEM DESIGN DOCUMENT AND DESIGN REVIEW

173. When developing a new system, whether or not it is to be built in-house or purchased from a systems house, there are trade-offs to be considered. In order to get the best system for your needs; budget, space allocations, and environmental constraints are some of the items which must be considered. The design document and the design review process has the tendency to cause rethinking of system requirements in terms of application. The design review process should involve as a minimum the system designer and a user representative. Normally, the design review team consists of a panel of three to five people who are experienced in system applications, system design, or system use. The interaction among various technical people reduces the chances of an oversight and also provides a nonpersonal vehicle for making system changes that fine tune it to the real world requirements. The real world requirements may include general information processing and storage or other uses, in addition to the primary purpose of data acquisition and alarms.

Guidelines for Preparation of a System Design Document

174. After the system requirements document is complete and all hardware is selected, a block diagram which includes all hardware units should be drawn. A list of all hardware and software should be made. The list should contain the following:

- a. Part and model numbers
- b. Manufacturers or vendors
- c. Addresses and phone numbers of manufacturers or vendors
- d. A description of the unit(s)
- e. Options required

- f. Accessories required (including reports)
- g. Costs
- h. Number (quantity) of units required

175. A site plan showing the placement of cabinets, units, tables, etc., at the site should be drawn. A detailed drawing of each cabinet with installed equipment should be completed. Cable details should be prepared, including signal line designation, cable type, length, connector types, and connector pin designations.

176. After this information is assembled, the system should be reviewed to check that all functions, units, cables, etc. are included.

177. Power requirements for the system should be determined and a drawing prepared to show power boxes, breakers, cable routing, and line conditioners or motor generator sets, if used. Grounding details should be defined and drawn. If the system requires a controlled environment, the heat generated by each unit should be determined and calculated into the figures for heating and cooling the room before the heating and cooling systems are ordered.

178. A form showing the type and format of data transfers between units should be prepared. This form saves time in developing software for the system.

Guidelines for Conducting a Design Review

179. The design review process must be kept on a nonpersonal plateau. When basic elements in the design review process are followed, it flows with few bottlenecks. The review

panel should be organized to the extent that a presenter and a secretary are named. The presenter is normally the designer or a person who knows the technical requirements of the system being reviewed. The secretary should be able to keep accurate notes of the interchange of technical information. The other members of the panel should have sufficient technical knowledge to understand the requirements.

180. A set of ground rules should be developed to prevent the meeting from turning into a new design definition session. The purpose of the design review is to determine if the design meets the design requirements set forth in the "Design Requirements Document." Although the design review process should not be a new design definition session, it should nevertheless be flexible enough to incorporate legitimate changes and omissions.

181. The design review should cover the entire system. Every component should be examined to verify that it will perform its intended function, without interfering with other system functions. Special attention should be focused on extenuating circumstances. The more "what ifs" discussed, the better the chances that the system will operate properly. Control and alarm functions of the system should be carefully examined to determine if they are sufficient to cover the needs of the operator, to protect the system, and will provide for the safety of the structure and personnel. Ergonomic aspects of the system are important factors in system design. Placement, ease of access, readability, the ability to interpret indications properly, and the general aesthetics of the system should be reviewed.

182. System hardware discussions should include the following:

- a. The number and type of sensors
- b. Type and location of signal conditioning
- c. Multiplexing
- d. Transmission techniques
- e. Signal conversions
- f. System interfaces
- g. Data storage and recording devices
- h. System capabilities
- i. System control and indication functions
- j. Electrical and physical environment
- k. Power requirements

183. System software discussions should include the following:

- a. Input data formats and polarity
- b. Operating system functions
- c. Languages used
- d. Memory management
- e. Memory capacity
- f. Data processing and storage
- g. Data storage formats
- h. Data recording and recording formats
- i. Operator interfacing with the system
- j. Overall system speed

PART V: SYSTEM IMPLEMENTATION

184. As the system moves into the implementation phase, the "how to get things done" stage becomes monumental because all pieces have to fit together. This section puts into perspective such tasks as system design, procurement, fabrication, integration, installation, and documentation. A typical method of system implementation is presented here to ensure that all necessary functions are performed and the hardware, software, and operating system are compatible.

Detailed Design

185. Information gathered in the system design document should be reviewed and included in the detailed design. Emphasis should be placed on site plans, power requirements, grounding plans, rack layouts, and cabling. Installation procedures and requirements should be reviewed for all system components. Any unusual procedures or requirements should be noted.

186. When required instruments are not "off-the-shelf" items, manufacturing drawings, wire lists, and assembly instructions should be prepared. Documentation of nonstandard instruments is critical, whether they are designed in-house or not.

187. Descriptions of nonstandard units should be specifically detailed in a design document. The design document should include a complete description of the function or functions of the unit with specifications. To hold the cost to a minimum, tolerances and capabilities should be no more than necessary but equivalent to other units in the system. A high quality amplifier for a low quality signal is as wasteful as a low quality amplifier for a high quality signal. Unit specifications should include all constraints such as size,

weight, power requirements, mounting, electrical, environmental, controls, speed, etc. Once the design of the unit is complete, an Assembly Manual should be prepared for fabrication. The Assembly Manual is a step-by-step description of how the unit is to be fabricated. When the unit fabrication is complete, a technical description should be prepared. The technical description should include all information necessary for the operation and maintenance of the unit. This information usually consists of electrical and mechanical drawings, a theory of operation, operating instructions, installation instructions, programming instructions, a parts list, and any other pertinent information.

Procurement and Receiving Inspection

188. The final system configuration will have an impact on the procurement and inspection process. For example: if the final system configuration is such that it is purchased as a system from a single manufacturer, the purchase agreement should include an on-site demonstration by the manufacturer to ensure that the equipment meets all applicable specifications. Purchase agreements for smaller systems and subsystems do not usually contain such agreements. Depending upon in-house resources and capabilities, the inspections not performed by manufacturers are performed either by in-house personnel, or third party service companies. Trade-offs are involved in the procurement/inspection process which should be resolved before procurement arrangements are concluded. For some systems, a source inspection (at the manufacturer's plant) and an on-site inspection may be desirable, while other systems may only require an on-site inspection. Yet, other systems or subsystems may be inspected on site by in-house personnel or third party service companies. Cost effectiveness of each type inspection ultimately determines the one selected. In any case, the method of inspection should be determined before procurement contracts are signed. Purchasing standard systems,

subsystems, or components is recommended whenever feasible to reduce costs. Standardization reduces costs in procurement of spare parts, documentation, and maintenance, in addition to reducing the requirements for writing detailed technical specifications.

Procurement

189. The procurement cycle normally commences with the final approval of system design. After design approval, a determination of long lead time items should be made in order to establish an ordering priority list. The purchase order should be generated in compliance with COE purchasing procedures. When standard components, subsystems, or systems are ordered by manufacturer, model number, etc., the actual technical specifications need not be stated on the procurement document. The manufacturer generally has published a specification sheet which gives all salient model specifications. When nonstandard equipment is procured and/or competitive bidding is required, all salient specifications must be stated on the procurement document.³³ Other requirements which need to be stated on the procurement document follow:

- a. A decision needs to be made as to source inspection (at manufacturer's plant) requirements. Normally, the government does not make source inspection on instrumentation systems. A more reasonable approach is to have an on-site inspection for larger systems and an in-house inspection for small systems and components. If a source inspection or an on-site inspection by the manufacturer (acceptance test) is to be made, it should be so stipulated on the procurement document.
- b. All system options need to be listed on the procurement document. Some manufacturers tend to offer several versions of a system to accommodate multiple-user requirements. Traditionally, the number of channels a system can handle is stated in terms of a minimum number such as 32, and is expandable by modules which come in multiples of some number such as eight (8) channels.

- c. If the systems, subsystems, or components purchased are to be acceptance tested or calibrated, a determination should be made as to "where" to ship the hardware. Shipping the equipment directly to the party who is going to perform the service, whether it be in-house or a contractor's facility, is recommended.

Receiving inspection

190. An inspection plan should be prepared to delineate the type of inspection to be performed and who will do it. This plan should define the type of documentation to be maintained; the procedure to be followed when material or articles do not conform to applicable drawings and specifications, or other requirements;³⁴ and the acceptance/rejection criteria.

191. The receipt of all new material and articles should be documented with sufficient information to satisfy COE property management requirements. A preliminary physical inspection of all incoming material and articles should be performed and any apparent damage noted on an inspection form, which becomes part of the permanent record. Those articles which require no further inspection should be sent to the designated system assembly storage area; those articles which require acceptance testing and/or calibration should be sent to the responsible testing authority. All articles damaged by the common carrier should be documented, and the carrier should be notified so that remedial action can be taken.

192. All sensors, instruments, and subsystems which contribute to the overall system accuracy and operation should be acceptance tested and/or calibrated. All nonfunctional hardware, such as cabinets, brackets, etc., may be visually inspected. Records of all inspections and tests performed should be maintained. These records show the initial status of an instrument and substantiate nonconformance and/or failure during the warranty period. They should contain sufficient information

to identify the material or article, the inspection or test involved, the nature of the nonconformances, and the causes for the nonconformances. When required, actual inspection and test results should be included.³⁵

Acceptance tests

193. The objective of acceptance tests is to verify that material and/or articles meet the supplier's stated specifications and/or the actual application requirements. Generally, the manufacturer's test/calibration procedures are followed to verify that specifications are met. Some of the tests are a go-no-go type while others are complete calibrations that require calibration standards traceable to the National Bureau of Standards (NBS), or a natural phenomenon. When applicable, test data should be recorded and retained. The test data are used to determine if the material or article passes or fails the test criteria.

194. When material or an article fails the acceptance test(s), it should be so noted and a determination made as to whose responsibility it is to make repairs and/or adjustments. The actual procedures used to resolve nonconformances vary among suppliers, but generally, the material or article is shipped to the respective supplier for adjustment/repair, or replacement.

CAUTION

The supplier should be contacted immediately for disposition before any on-site attempt is made to correct the problem, or else the warranty may be voided.

In some special cases, a supplier or his representative makes on-site corrections, especially when large single source systems are involved or when specifically stated on the procurement documents.

Metrology controls

195. Generally, there are components within an instrumentation system which should be calibrated and placed in a documented metrology control/recall system. The documented metrology system should provide evidence of quality conformance.³⁶ Components normally placed in a metrology control/recall system are: sensors/transducers, amplifiers, filters, voltmeters, analog-to-digital converters, and calibration standards. These components should be assigned calibration intervals based upon manufacturers' recommendations, the Navy's METRL, or COE manuals. The intervals should be reviewed periodically and adjusted according to the history of whether or not the equipment is out of tolerance at the time it is calibrated. In establishing intervals, consideration should be given to the use, accuracy, type of standard, required precision, and other conditions adversely affecting quality.

196. All standards and equipment used in measurement processes should be in a recall system. Controls should be established to ensure that those instruments which are not calibrated within the established interval be immediately recalibrated or removed from service. All equipment in the recall system should have a label or tag affixed to indicate the calibration status and due date of the next calibration. The calibration record system should provide sufficient information to determine calibration results, traceability to the NBS, date of calibration and the interval or next calibration date.

System Fabrication

197. When instrumentation systems are not procured as turnkey systems, it is likely that nonstandard hardware will be required. Fabrication of this hardware may be accomplished in-house or contracted to specialty vendors. A make or buy decision

needs to be made early, so that system integration and installation is not delayed.

198. Several categories of component devices are likely to need special attention. They are mounting brackets, cables and wiring, cable troughs, and electronic interface devices. Particular attention should be given to the quality of materials used, clarity of panel markings, selection of paint, routing of cable harnesses and the placement of clamps, location of rear panel connectors and associated connector labels, and general workmanship during the fabrication process.

199. Detailed electrical and mechanical drawings and, in some cases, component layout diagrams should be prepared before fabrication commences. In order to achieve proper system operations, other documentation, such as hardware and electronic component specifications, input/output (electrical) voltage levels, and impedances should be specified. The documentation will be required whether or not the fabrication is done in-house or contracted to a specialty vendor.

System Integration

200. The staging or integration of the system for both hardware and software should take place at a central facility where labor and material resources are readily available, and not at a remote location or facility. The system integration phase occurs when all individual parts of the system, both hardware and software, are brought together and are made to function as a system.

201. Hardware integration consists primarily of cabling all units together. At this time, problems with missing cables or cables with the wrong size or type connectors are found and corrected. After all the hardware is assembled and cabled

together, each cable should be tagged. When the system is inventoried and packaged for delivery to its permanent location, it should include all tagged cables for a quick and correct installation. At this point, a word of caution regarding individual unit warranties seems appropriate. Each manufacturer has specific rules regarding what voids a warranty. Therefore, before opening a unit or removing the covers from a unit, the owner's manual or warranty card should be checked. In some cases, it may be necessary to intentionally void the warranty in order to modify or interface the unit into the system.

202. The application of AC power to the system should be done slowly, carefully, and unit by unit. Although each unit was verified as operating properly during acceptance testing, it may have developed problems or the interface cabling may be incorrect. After power is applied to all units of the system, each unit should be verified as being operational. Testing at this point need not be as complete and thorough as during acceptance. Use of unit self-tests and basic functional tests is sufficient if the system is computer-based and the software integration phase is to be conducted next. For noncomputerized systems, the next phase is final checkout.

203. Software integration is very similar to hardware integration. First, the computer is verified as operational by running the appropriate CPU and memory diagnostic. Then each standard peripheral such as disks, tape drives, and printers, should be verified using standard diagnostics. The nonstandard devices such as A/D converters, multiplexers, and other signal conditioning equipment must be verified with purchased or self-written diagnostics. If diagnostics are not available, then "thumb-ins", short ASSEMBLY or BASIC language routines, should be used to verify functional operation. At this point, the computer operating system (OS) should be loaded into the computer and tested. If the OS does not contain all necessary drivers and

software routines to communicate with each peripheral device, they should be added and tested. At this point, the operation of each unit and device should be verified using the system software.

204. An operational readiness test program is used as the first level of diagnostic and basic test of system operability. If available, it should be loaded, tested, and followed by the system calibration program and the data acquisition program.

205. The final checkout phase of system integration consists of verifying the proper operation of the data acquisition program with all system hardware. To minimize software and hardware design problems at the permanent installation, this verification should closely simulate the site-installed configuration. Interface cables of the same length as those to be installed at the site should be used. A complete set of sensors similar to those at the actual site should also be used or simulated as closely as possible. As the last step in the system integration phase, the final hardware and software configuration should be documented in the system installation manual.

System Installation

206. System installation actually commences during the system design phase when the physical layout or site plan is drawn. Before the main components of the system arrive at the installation site, the site plan must be verified against the space allocated. The installation of cabling and outlets for power and communication lines, as well as data path cables to and from sensing devices, should be checked and verified. All cables and connectors should be properly tagged to conform with the system interface drawings.

207. COE sites are often environmentally harsh and hazardous to automated instrumentation. The area which houses the main components of the system should be thoroughly cleaned and the cooling/heating systems verified just before the arrival of the system. Dust, especially concrete or cement dust, from construction or renovation causes air flow filters to clog and magnetic media to be severely damaged; thus, the elimination of as much contamination as possible will prevent many future problems.

208. To prevent or at least minimize damage to all sophisticated and expensive equipment, special protective measures and techniques should be implemented during instrument installation at field sites. The two primary environmental hazards associated with COE sites and concrete dams are: 1) the natural elements of temperature excursion and moisture condensation, and 2) the induced element of physical abuse, unintentionally by site personnel and intentionally by vandals.

209. In areas that are subjected to wide temperature variations and water/moisture exposure, instruments should be enclosed in environmentally-conditioned cabinets or rooms. To reduce moisture condensation and corrosion damage and limit temperature excursions, simple electrical heater strips or light bulbs may be installed within the instrument enclosure or room. A commercial-grade electrical insulating varnish or equivalent coating should be sprayed over all exposed electrical connections to protect them from corrosive moisture. Generally, computers and associated peripheral instruments should be environmentally protected with thermostatically-controlled temperature and moisture conditioning equipment.

210. To preclude physical damage to instruments and equipment, they should be installed in metal cages, cabinets, or equally sturdy enclosures or shelters. For personnel and

equipment safety, adequate lighting should be installed in all equipment areas in which technical personnel will interact with the instrumentation. To limit the damage by vandalism at COE sites on public lands, all equipment (instrumentation and cables) should be enclosed in protective shelters and, if possible, hidden from normal view (out-of-sight, out-of-mind theory). All enclosures that are exposed to weather and public access should be environmentally protected, and fabricated with steel plating and padlocks.

211. Upon the arrival of the system at the field site, it should be inventoried against the packing list. Special emphasis should be given to verifying that all interface cables are on hand. The installation team should consist of the system integration team or at least one member of the team. At least one person should be familiar with the system layout and the system operation to assure that the installation and checkout is done quickly and efficiently.

212. The equipment should be physically placed in accordance with the site plan. Before connecting primary power to each unit, the outlet or junction box should be checked for proper wiring and grounding. The interconnecting cables should then be installed between components of the system and to the sensors.

213. Any changes, corrections, or modifications that are made to the installation must also be made to the site plan and cabling drawings at the time the changes are actually made. It is very important to future maintenance of the system that the system installation manual be totally accurate.

214. After all equipment is in place and all cables are connected, power may be applied to the system and the check-out phase of the installation may commence. Each unit of the system

must be verified for proper operation, both stand-alone and as a part of the system. All problems encountered should be noted and corrected before final acceptance of the system.

215. Final acceptance of the system also affords a good opportunity for user training. Having the system user perform all functions and tests that are to be implemented, not only tests the operability of the system, but also allows the user actual hands-on training.

216. As the last step in system installation, the system installation manual should be verified against the installed configuration. Any discrepancies should be resolved so that the information in the manual reflects the actual installation.

Documentation

217. Documentation of the system commences with the initial System Requirements Document and continues through the System Installation Manual. All system documentation must be maintained and updated throughout the life of the system. Documentation for individual units of the system is covered in Part VI, Maintenance Documentation.

218. System documentation, unlike unit documentation provided by the equipment manufacturer, normally must be written specifically for each system. The primary purposes of system documentation are: operation, how to operate the system; modifications, how to modify the system by adding more hardware or changing the software; and maintenance, how to maintain the individual components of the system. Operation, modification, and maintenance apply equally to both system hardware and software.

219. The operations manual should include step-by-step procedures for all functions normally performed by a system operator. It should include what to do when things are working correctly, and also what to do when things are not progressing according to the procedures.

220. The System Theory manual may in fact be more than one manual as both the hardware and software that make up the system need to be addressed. The hardware manual or section should, as a minimum, include the final system requirements, system design documents, a system level block diagram, and a written theory of its overall system operation. Details on the operation of each individual unit need not be included as those information are available in the documentation provided by the equipment manufacturer. The software manual or section should contain a system level flow chart depicting the major software activities, a brief theory on the major portions of the program, and a table or tables depicting error messages, alarms, and predetermined set points or interrupts that automatically modify system operation. However, the major portion of the software documentation should be program listings containing comment statements for clarity of meaning. Future maintenance or modification of the software requires that this documentation be complete and accurate, and be updated during the life of the system.

221. At least two complete sets of documentation should be supplied with the system. One set should remain with the system; the other set should be maintained at a central location for reference by engineers who have responsibility for system maintenance or modification.

PART VI: MAINTENANCE

222. Developing a system maintenance philosophy is an intricate process which requires forethought and planning. Some of the elements which must be resolved are: the complement of maintenance technicians, a centralized or decentralized program, the level of spare units or components to be maintained, and the amount of system downtime that can be tolerated. Once answers to these questions are found, the overall maintenance program can be developed. The steps involved in designing a maintenance program are discussed below. A well-planned maintenance program results in a system which performs as expected and remains operational for many years.

Maintenance Philosophy

223. Establishing a maintenance philosophy should be undertaken early in the system design stage rather than as an afterthought. This is especially important when the budget is restricted. A well-designed, automated system is of little use if it fails and can't be repaired due to a lack of manpower or material budget.

224. Several considerations must be evaluated when establishing a maintenance philosophy. They are of varying levels of importance relative to each other, and are interdependent upon each other.

Types of Maintenance

225. The decision to use contract maintenance, self-maintenance, or some combination of the two is of primary concern. This decision must be based upon available technical knowledge and manpower. Total contract maintenance requires the least amount of in-house skilled manpower. Total self-

maintenance requires the greatest complement of skilled manpower, but may result in lower maintenance costs. A combination of self-maintenance, at the local or site level, and contract maintenance at a depot or centralized location, results in a controllable balance between on-site manpower requirements and maintenance costs.

Level of Repair

226. Should repair be localized or centralized? This consideration is very closely related to the types of spare parts and test equipment provided at each echelon. The local or on-site repair of systems may be accomplished with available manpower and virtually no test equipment, if it is performed by using unit- or assembly-level spare parts. "Swapping out" units or major assemblies to restore system operation is by far the fastest method.

227. On-site repair to the subassembly or module requires more manpower, a higher level of training, and more test equipment. The cost of spare parts is not reduced significantly. In many cases, the cost to provide 90% to 100% spare subassemblies or modules can equal or exceed the cost of a complete unit.

228. On-site repair to the component level requires the largest investment in manpower, training, and test equipment. However, the cost of spare parts is reduced significantly.

229. Second echelon or regional repair applies if other than component-level repair is accomplished on site. The regional level depot repair may be established as a subassembly repair center. The subassemblies or modules should be returned to the centralized depot or manufacturer for repair, or another component level repair facility.

230. The third or final echelon may be a national repair center or a depot capable of providing component-level repair and calibration for all equipment making up similar systems throughout the country.

Preventive Maintenance

231. Preventive maintenance (PM) is the prevention of equipment failures. It may be as simple as cleaning air filters, or as complex as planned replacement of an entire data acquisition system. Each system requires a schedule of preventive maintenance activities. The activities to be performed and the frequency at which they are performed are governed by such things as: 1) equipment manufacturer's recommendations, 2) environmental conditions, 3) history of performance, and 4) remoteness of sites and the frequency of visits to the sites.

232. Each manufacturer normally includes, as part of the operations or maintenance manual, a section on the frequency schedule and activities that should be performed to verify proper operation and to prevent failures. In-as-much as a system is a combination of individual pieces, each with its own frequency of recommended preventive maintenance activities, a "master" or system PM schedule must be developed. The manufacturer's recommended frequencies must then be reviewed and modified to reflect the environment in which the system is operating, i.e., an extremely dusty or dirty environment requires increasing the frequency at which air filters are cleaned or replaced. Operation of a system in a specially prepared computer room with an ideal environment requires less frequent PM. A PM schedule modified to reflect environmental conditions should be reviewed based upon actual performance history of the instruments in similar conditions. This review process, based upon actual

history, can and should be a continuing process. In the event that the manufacturer's literature does not contain a section on PM activities and frequencies, the instrument in question must be compared to similar instruments to establish an initial PM schedule. If similar instruments are not available, a "best guess" schedule of PM activities and frequencies must be established. Preventive Maintenance of a totally electronic instrument requires only an occasional cleaning. If an instrument contains fans and filters, they must be cleaned and checked for proper air flow at a frequency dependent upon the operating environment. On the other hand, electromechanical and mechanical instruments require periodical cleaning and lubrication. If no other guidance is available, a conservative schedule with short PM intervals should be established. As experience in instrument performance is obtained, the user may appropriately adjust the PM interval.

233. The installation of data acquisition systems at unmanned remote sites presents entirely different problems. The previously developed PM schedule may be totally impractical because of manpower shortages or extremely difficult access. Under such circumstances, a trade-off between manpower and the loss of all or a part of the system must be made. Therefore, any visit to a remote site to correct a known problem or to collect data, etc., should be combined with a PM visit.

Calibration

234. To assure that accurate data are collected by the data acquisition system, the various units of the system and the system as a whole require calibration. The type, accuracy, and frequency of calibrations must be addressed during the system design.

235. During the acceptance of the various components of the system, each unit should undergo precision calibration. All sensors, especially those that are inaccessible after installation, should be verified for proper operation and accuracy by a competent calibration laboratory that can produce or simulate the phenomenon to be measured. Each sensor should be delivered with a data sheet. The strictly digital instruments, and digital inputs and outputs need only be verified for operation, as no calibration is required.

236. Once the system is staged, i.e., put together, and its operation verified before installation, it should be calibrated by using an electronic voltage standard in place of the actual sensors. At this time, true system operation and accuracy may be tested and verified.

237. When the system is completely installed, the same procedure as described above should be repeated. At this time, either hardware or software adjustments may be made to each sensor channel to assure that the value computed and output by the system is consistent with the input.

238. Periodic calibration of the system may be accomplished either manually or automatically. Manual calibration requires that a standard voltage be substituted for the sensor output, either one channel at a time or all channels simultaneously. This known input used with a software calibration program allows verification and adjustment of the system for proper readings. The frequency at which scheduled manual calibration should be done depends upon available manpower, test equipment, and the criticality of the sensor readings. This procedure has to be accomplished if the system signal conditioning equipment, cabling, or any other portion of the system that affects the analog data are replaced or repaired.

239. Automatic system calibration requires the installation of a programmable voltage standard, associated calibration relays, and a calibration program. This method allows calibration of the system by the repair technician after a repair or PM and without additional test equipment. The point of calibration signal injection determines the level of system performance or confidence that may be derived from the system calibration. If the calibration signal is injected at or as physically close to the sensor output as possible, the highest level of confidence in the overall system performance may be achieved by a successful calibration. In addition to calibrating the system and verifying its operation, this method may be used to assist in troubleshooting the system. This is especially true if the calibration signal is injected at various points along the data path. The frequency at which an automatic calibration can be run is practically unlimited, as it may be programmed to require no operator/technician intervention. The output of the calibration program may be evaluated by the processing unit, and failures or out-of-tolerance readings can be used to trigger either local or remote alarms.

240. Signal conditioning equipment that is returned from repair at a regional or national depot requires calibration. Each unit must be calibrated or aligned to meet the manufacturer's specifications. Thus, sufficient test equipment to accomplish the required level of accuracy must be available at the repair depot.

Documentation

241. The purchase agreement should require each equipment manufacturer to provide sufficient documentation to facilitate the component level repair, alignment, and calibration of their respective instrument. The required documentation is packaged and identified differently by each manufacturer. Three major

categories of documentation are required to properly maintain any unit of electronic or electromechanical equipment. Although the sources may be titled differently, the basic information required is as follows:

a. The reference manual should contain basic information on the functional use, operation, and programming of the unit. It also includes the basic input and output parameters of the unit. This manual is to assist the maintenance technician during the problem identification phase of repair. It answers many important questions such as:

1. How does the unit operate?
2. Is the output of the unit correct?
3. Is the input to the unit correct?
4. Is the unit functioning correctly?

b. The service manual describes the causes for certain failures, and how the technician isolates and repairs these problems. This manual also contains detailed specifications on the unit and defines external power requirements, internal power requirements, signal voltages, signal frequencies, and signal wave shapes of the unit. It normally lists the tolerances for these specifications at their source as well as various test points throughout the unit. This manual normally contains a unit theory of operation, as well as a breakdown of the major assemblies and subassemblies and a theory of operation for each. It should also contain calibration information for the unit and/or its subassemblies; how to perform adjustments and alignments; and how to assemble and disassemble the various assemblies and subassemblies that make up the unit. Depending upon the type of unit covered by the service manual, there are other helpful hints for the repair technician such as:

1. Procedures to set up and run troubleshooting program loops.
2. Signature analysis patterns.
3. Test patterns.
4. Troubleshooting charts.

5. Lists of recommended spare parts.
 6. Preventive maintenance procedures and recommended frequencies.
 7. The address and telephone number of the manufacturer's technical assistance department.
- g. The drawing package contains schematic or logic diagrams which are absolutely necessary for component-level repair of assemblies and subassemblies. Also, this package usually contains an illustrated parts breakdown (IPB) and the mechanical drawings of all component hardware. Without this drawing package or the equivalent information, component-level repair can only be provided by the manufacturer or some other source with the documentation required.

242. Complete and accurate system maintenance documentation for each system installed cannot be overemphasized! This is especially true for multivendor systems, and it is also as applicable for single-vendor systems. Even the best repair technician can spend hours, even days, trying to determine which options, addresses, and configurations of equipment are connected to make a system. Computers, peripherals, and computerized signal conditioning equipment are built for general purpose use. Options, switch settings, and interfacing is then customized for specific applications. The technician must know the specific configuration of the system that he is expected to repair.

243. The system integrator, vendor, or system engineer should be required to provide a system installation or system configuration manual. This must be updated to reflect the actual configuration of the system after installation and acceptance. Additions, deletions, and any modifications to the system should be documented in the system installation manual. The time, effort, and cost to obtain and maintain this manual may be paid back by each system problem that is resolved by the technician in hours rather than days or weeks. The manual should be brief but complete. Specific information on each unit can be found in the

respective maintenance manual for each unit and need not be repeated in this manual. The system installation or configuration manual should contain as a minimum the following:

- a. Site plan (equipment locations).
- b. Power wiring and power source drawings.
- c. Cable routing and identification drawings.
- d. Computer bus priority scheme.
- e. Computer bus addressing, vectoring, or unit recognition scheme.
- f. Unit identification (keyed to the site plan), i.e., manufacturer, model, and a list of available documentation for the unit.
- g. List of applicable software tests and/or diagnostic programs. This should include a brief description of how to run each test or diagnostic program, and what to expect while it is running and upon successful completion.

244. The location and quantity of each manual are dependent upon the maintenance philosophy chosen. Reference, service, and site installation manuals should be located at the equipment site, or they must be carried with the service technician on each corrective or preventive maintenance visit. The schematic drawings manual is normally required to be at the location where the component-level repair is performed. In a three-echelon maintenance philosophy (on-site, regional repair, and central repair), one master copy of each manual should be maintained at the regional and central repair facility for backup in the event the site copy is lost or destroyed, and for reference by technical specialists and engineers who may be asked to provide assistance to on-site repair technicians. This documentation also provides quick reference for the engineer who is tasked with upgrading or modifying an existing system. In addition to the hardware documentation, software documentation

should also be available at the regional and/or central repair facility. Diagnostic, system test, and operating system reference manuals can be used to provide useful troubleshooting information to the on-site technician.

Maintenance Software (Diagnostic)

245. Diagnostic software of different levels is required for maintenance troubleshooting of computer system hardware. The first level of on-site diagnostics should be developed or modified for each specific system and used as an operational readiness test. It need only verify basic communications between units or devices, and fundamental operations of each device such as: 1) Are the sensors connected to the system? 2) Are the sensor readings reasonable for existing conditions? 3) Can the magnetic medium write, read, etc? Additionally, an on-line/off-line calibration diagnostic program should be incorporated into the system software. Although it is more time-consuming to run than the operational readiness test, a thorough system calibration program is used to find units which, although functional, are not operating within specifications and require replacement, alignment, or recalibration. In addition, use of such a program gives a higher level of confidence in a system's general performance.

246. Diagnostics for subassembly or module level maintenance are very complex and time-consuming to run. They are device-specific and must verify all functions of a device. This type of diagnostic program is normally available from the equipment manufacturer and should be purchased simultaneously with the equipment. Further diagnostic programs for component-level troubleshooting are also necessary.

247. Some diagnostic programs for microprocessor-based test equipment, large analyzers, and microprocessor

troubleshooters are available from test equipment manufacturers. However, at this level of troubleshooting, most programs or troubleshooting routines are written and developed by the repair technician.

248. Software for automated calibration of sensors and signal conditioning devices is also a necessity if the devices are to be calibrated on site. This software may be purchased from equipment manufacturers and customized for specific system configurations, or developed from "scratch".

249. If the data acquisition systems are on-line to central points of data collection, a remote diagnostic feature may be used to save a significant amount of time and effort. A remote diagnostic permits the technician to run and evaluate the operational readiness test and the system calibration program. This procedure informs the repair technician about a problem before leaving the central site, and allows him to select proper parts and test equipment to complete the repair. Knowing the operating condition of a system allows flexibility in assigning limited manpower to respond to preventive and corrective maintenance situations.

Spare Parts

250. The establishment of a spare parts inventory, whether at the component, subassembly, assembly, or unit level of maintenance, or at some combination of these, is a must. The location and type of spare parts are determined by the overall maintenance philosophy. However, one central computerized inventory that shows parts availability, status, and location can eliminate unnecessary duplication and results in the most cost-effective inventory. This type of inventory file also allows the stocking and cross-referencing of generic parts rather than original equipment manufacturers' (OEMs') parts. This allows for

cost savings in the purchase price and may well eliminate duplication of items for different OEMs.

251. The depth of the spare parts inventory is governed mainly by the budget available and the failure history of the parts. However, false economies in the establishment and maintenance of a spare parts inventory can result in significant costs in manpower and lost system availability. At all but the component level of repair, it is far more economical for the person troubleshooting a problem to "swap out" a suspected faulty part than to take the time to isolate the malfunction with elaborate test equipment. The decision on what should be included in the initial inventory of spare parts to support a data acquisition system should be made based upon a combination of each equipment manufacturer's recommendation; the known history of the equipment, if available; and experience gained in maintaining similar equipment.

252. On the average, electromechanical components are subject to more failures than purely electronic components. Therefore, the inventory composition should accommodate the additional electromechanical component failures. The number of each item in the inventory should be minimized initially, and then increased, as necessary, based upon failure history and the repair or replenishment time for the item. One should also consider the form of spare parts maintained in the inventory, i.e., discrete components, modules, or complete units. For example: if a minimum level of 60% of the parts for a unit is to be stocked as spares, what is the discrete parts cost relative to the cost of an entire unit? If major subassemblies, modules, power supplies, etc. are purchased, the cost could be as high as 80% or 90% of the unit cost. If the cost of the discrete parts approaches, equals, or exceeds the cost of the whole unit, it is more cost-effective to buy an entire unit for spare parts. This can result in 100% sparing at a slightly increased cost.

Replacing a faulty unit with an operational spare assures that the system remains functional during the repair of the unit, and that the unit removed is in fact the unit with the problem.

Test Equipment

253. The choice of test equipment depends largely upon the level of maintenance to be performed. For assembly or unit level of maintenance, only the very basic test equipment is required. A complete electronic technician's tool kit, which includes a hand-held multimeter and a data communications tester, is considered sufficient. Diagnostic software and system operational readiness tests are used to isolate an inoperative unit, and to verify proper operation after a unit or assembly is replaced.

254. For subassembly- or module-level maintenance, several more sophisticated pieces of test equipment are required in addition to those previously specified. Component-level repair is normally done at a regional or central depot because of the large amount of sophisticated test equipment, special purpose tools, solder station, disk and/or tape head alignment tools, and technical expertise that are required to replace failed components or align replacement components. Precision calibration of various sensors is also performed at depots.

255. Table 5 provides a guide regarding the major tools and test equipment generally required at the various maintenance levels.

Training

256. Training is a basic requirement regardless of maintenance philosophy. Attempts at remedial maintenance by inexperienced/untrained personnel may well leave an entire system inoperative when the original problem was only minor. There are

several levels and types of training. The basic level of training for the operator/technician who maintains the system and provides the operator function is knowledge of unit "swapping".

Table 5
Maintenance Test Equipment Distribution

| <u>Assembly/Unit Level Repair</u> | <u>Subassy/Module Level Repair</u> | <u>Component Level Repair</u> |
|--|--|---|
| 1. Complete ET tool kit | 1. Same | 1. Same |
| 2. Hand-held VOM | 2. Same | 2. Same |
| 3. Data communications tester as appropriate | 3. Same | 3. Same |
| | 4. Portable 35-MHz dual-trace oscilloscope | 4. Same |
| | 5. Bus exerciser/analyzer (type depends upon bus) | 5. Same |
| | 6. Portable voltage standard | 6. Same |
| | 7. Digital multimeter | 7. Same |
| | 8. Master skew tape & master output tape for systems using magnetic tapes | 8. Same |
| | 9. Disk exerciser, alignment disk, & scratch disks for systems having disk drive units | 9. Same |
| | | 10. Bench type 100-MHz oscilloscope |
| | | 11. Logic analyzer (time & logic state) |
| | | 12. Microprocessor troubleshooter |
| | | 13. One of each unit to be maintained to be used as a test fixture for troubleshooting & verifying repair |

257. Of primary importance, the technician should be able to remove and apply source power to the system and to the individual units that make up the system. The second item is how to load and unload the storage media, magnetic tapes, or disks. This includes performing the actual physical act and informing the system that the recording media is replaced. Also, the first level maintenance technician should know all system operator functions for the specific system, as well as preventive maintenance functions. For a computerized system, the operator/technician also needs to receive training on the software operating system, system operating commands, the system operational readiness test, calibration programs, and hardware diagnostic programs. The operator/technician must understand these programs to be able to load and execute the desired program, to determine if the program is operating properly, and to interpret the results.

258. The operator/technician should be given instruction in the use of the system installation manual and the configuration of switches on equipment within the manual. This basic level of training allows any person to function as the system operator and the first echelon repair technician to perform a "unit swap" method of maintenance.

259. The second level of training should cover assembly and subassembly level of repair. This requires an electronic technician who has received training in the fundamentals of electricity, basic electronics, digital theory, use of general electronic test equipment, and the fundamentals of computer systems and peripherals. In addition, the technician should be provided with the operator/technician training and an in-depth familiarization on the units that make up the system. Specific unit level training should cover special alignment, adjustment, and field calibration procedures for each unit. An understanding

of the applicable unit diagnostic software is also required at this level of repair.

260. The final level of repair, circuit component isolation and replacement, requires training given at both previously discussed levels, plus the theory of operation of all electronic circuits and electromechanical and mechanical components in each unit. In addition, the technician should receive advanced-level training in electronics, digital theory, computer systems, and in the use of advanced-level electronic test equipment.

261. The methods of training range from on-the-job-training (OJT) to formal manufacturer's classroom instruction. Whether planned or unplanned, OJT takes place constantly from an instructor, fellow technician, or technical service manuals.

262. System maintenance training, regardless of the level, must be customized for the specific system. The simplest and by far the most economical method of conducting this type of training, especially when turnover of personnel is high, is by the use of video training tapes. This method, unlike classroom presentation, may be used over and over. In addition, if a video cassette recorder (VCR) is readily available, the tapes may be viewed or reviewed by the operator or maintenance technician at any time. This method of training is also ideally suited to both preventive and corrective maintenance procedures. It allows the viewer to see the procedure actually being performed, and demonstrates techniques in minutes that would take chapters in a manual to describe. Also, infrequently performed procedures may be reviewed by the technician before performing the task.

263. The most formal and overall the most expensive type of training is the manufacturer's factory school. This training generally takes place at the equipment manufacturer's facility.

It is normally taught by a trained professional instructor and normally delves deeply into the theory of operation of the equipment. If the course includes laboratory time, actual hands-on training accompanies the theory training. This type of training also requires the loss of availability of the technician(s) for the duration of the course.

264. The type of training chosen need not be limited to only one of the types previously discussed, but can include any or all of the various types put into a format suited to the needs and budget of the project.

GLOSSARY

Abbreviations, Acronyms, and Terminology

| | |
|-----------------------------------|---|
| Access Time | The delay between the time when a memory receives an address and the time when the data from that address are available at the outputs. |
| Accumulator | A register that is the source of one operand and the destination of the result for most arithmetic and logical operations. |
| Accuracy | The ratio of error to the full-scale output or the ratio of the error to the output, as specified, expressed in percent. |
| Active-high | The active state is the one state. |
| Active-low | The active state is the zero state. |
| Address | The identification code that distinguishes one memory location or input/output port from another and that can be used to select a specific one. |
| Addressing Methods (Modes) | The methods for specifying the addresses to be used in an instruction. Common addressing methods include direct, indirect, indexed, relative, and stack. |
| ALGOL | Algorithmic Language, a widely used high-level language designed for systems and scientific applications. |
| Aliasing | The appearance of incorrect frequencies in sampled dynamic data due to inadequate sample rates. The sum and difference of sample and signal frequencies will appear in the reconstructed waveform if they are not filtered out and/or the sample rate is not sufficiently high. |
| AM | Amplitude modulation, a type of modulation where the carrier (q.v.) is varied in its amplitude in sympathy with an information signal. |
| Ambient Conditions | The conditions (pressure, temperature, etc.) of the medium surrounding the case of the transducer. |

Analog Continuous signal or representation of a quantity that can take any value.

Analog Output Transducer output which is a continuous function of the measurand, except as modified by the resolution of the transducer.

Analog Transmission Transmission system in which the modulation of the carrier varies in exact sympathy with the information signal.

Anode Positive terminal.

ANSI American National Standards Institute.

Architecture Structure of a system. Computer architecture often refers specifically to the CPU.

Arithmetic-Logic Unit (ALU) A device that can perform any of a variety of arithmetic or logical functions under the control of function inputs.

Arithmetic Shift A shift operation that preserves the value of the sign bit (most significant bit).

ASCII American Standard Code for Information Interchange, a 7-bit character code widely used in computers and communications.

Assembler A computer program that converts assembly language programs into a form (machine language) that the computer can understand. The assembler translates mnemonic instruction codes into binary numbers, replaces names with their binary equivalents, and assigns locations in memory to data and instructions.

Assembly Language A programming language in which the programmer can use mnemonic instruction codes, labels, and names to refer directly to their binary equivalents. The assembler is a low-level language, since each assembly language instruction translates directly into a specific machine language instruction.

Asynchronous Operating without reference to an overall timing source, that is, operation at irregular intervals.

Attached Input/Output An addressing method for input/output ports that identifies the ports either directly (if the port is attached to the CPU) or from the address in memory to which the port is attached.

The port is usually selected with special instructions that are decoded either in the CPU or in the memory section. Systems using attached I/O are frequently based on LSI devices that combine memory, input/output, and processor functions.

- Audio Frequency** Frequencies which fall within the range of hearing of the human ear, about 20 Hz to 20 kHz.
- Autoindex** An index register that is automatically incremented (autoincrement) or decremented (autodecrement) with each use.
- Automatic Calling Unit** A computer-controlled device for generating dial-up signals into a telephone network.
- Autoranging** Capability of an input channel to change its range or gain to a value appropriate to the input level. May be done by hardware or software.
- Auxiliary Carry Bit** See Half-Carry Bit.
- Bandwidth** Range of frequencies which a channel is capable of transmitting.
- Baseband** The original frequency components of an information signal.
- Baud** A communications measure for serial data transmission, bits per second but including both data bits and bits used for synchronization, error checking, and other purposes.
- Baud Rate Generator** A device that generates the proper timing interval between bits for serial data transmission.
- BCD** Binary coded decimal. A method for representing decimal numbers whereby each decimal digit is separately coded into a binary number.
- Benchmark Program** A sample program used to evaluate and compare computers.
- Best Straight Line** A line midway between the two parallel straight lines closest together and enclosing all output vs. measurand values on a calibration curve.
- Bidirectional** Capable of transporting signals in either direction.

| | |
|-------------------------|---|
| Binary | Number system with base 2; having two distinct levels. |
| BIOS | Basic Input/Output Software. |
| Bit | A binary digit, possible values zero or one. |
| Bit slice | A section of a CPU that may be combined in parallel with other such sections to form complete CPUs with various word lengths. |
| Bootstrap Loader | (or Bootstrap) Technique for loading first instructions of a program into memory and then using these instructions to bring in the rest of the program. The first instructions (called the bootstrap) may reside in a special read-only memory (ROM). |
| Borrow | A status bit that is one if the result of an unsigned subtraction was negative. |
| BPS | Bits per second (sometimes shown as bps). |
| Breakpoint | A location specified by the user at which program execution is to end temporarily. Used as an aid in program debugging. |
| BSL | Best Straight Line. |
| Buffer | Storage area for intermediate data, sometimes used to accommodate speed differences in data rate. |
| Bus | A group of parallel lines that connect two or more devices. |
| Bus Driver | A device that amplifies outputs sufficiently so that they can be recognized by the devices on a bus. |
| Bus Isolation | Buffering parts of the bus away from other parts with buffers and drivers. |
| Bus Transceiver | A device that acts as both a bus driver and bus receiver; that is, it interfaces a bidirectional bus to two unidirectional buses. |
| Byte | The basic grouping of bits that the computer handles as a unit, most often eight bits in length. |

Calibration A test during which known values of measurand are applied to the transducer and corresponding output readings are recorded under specified conditions.

Calibration Curve A graphical representation of the calibration record.

Calibration Cycle The application of known values of measurand, and recording of corresponding output readings, over the full (or specified portion of the) range of a transducer in an ascending and descending direction.

Calibration Traceability The relation of a transducer calibration, through a specified step-by-step process, to an instrument or group of instruments calibrated by the National Bureau of Standards.

Calibration Uncertainty The maximum calculated error in the output values, shown in a calibration record, due to causes not attributable to the transducer.

Carrier A single frequency capable of being modulated by an information signal.

Carry Bit A status bit that is one if the last operation generated a carry from the most significant bit.

Cartridge A compact, enclosed package of magnetic tape that uses 1/4-inch tape and records 1600 bits per inch at 30 in/sec on four tracks.

Cassette An enclosed package of magnetic tape usually housed in a plastic container. Both audio and digital versions exist; the digital ones are more reliable and more expensive. The standard unit is the Philips-type cartridge, which consists of 282 feet of 0.015-in. magnetic tape, phase encoded at 800 bits/inch.

Cathode-Ray Tube An electron-beam tube in which the beam can be focused to a small cross section on a luminescent screen and varied in position and intensity to produce a visible pattern.

Center of Seismic Mass The point within an acceleration transducer where acceleration forces are considered to be summed.

Central Processing Unit (CPU) The control section of a computer. It contains the arithmetic unit, registers, instruction-decoding mechanism, and timing and control circuitry.

Channel A path along which a signal can be sent.

Checksum A logical sum of data that is included in a record as a guard against recording or transmission errors.

Chip A substrate containing a single integrated circuit.

Clear Set state to zero; an input to a device that sets the state to zero.

Clear-to-Send An interface signal generated by a modem to indicate its readiness to receive data.

Clock A regular timing signal that governs transitions in a system.

CMOS Complementary metal-oxide semiconductor, a logic family that uses complementary N-channel and P-channel MOS field-effect transistors to provide high noise immunity and low power consumption.

CMR See Common-Mode Rejection.

CMRR See Common-Mode Rejection Ratio.

CMV See Common-Mode Voltage.

Coding The writing of programs in a language that is comprehensible to a computer system.

Common-Anode Display A multiple display in which signals are applied to the cathodes of the individual displays and the anodes are tied together to the power supply. Uses negative logic, (i.e., a logic zero turns a display on).

Common Carrier A designee of the Federal Communications Commission, providing telephone and other communications services under public utility regulation.

Common I/O Uses the same lines for input and output.

Common-Mode Rejection (CMR) The ability of differential amplifiers to cancel a common-mode voltage.

Common-Mode Rejection Ratio (CMRR) The ratio of the open-loop normal (differential) signal gain to the open-loop common-mode signal gain in operational amplifiers. Typical values of CMRR are 70 to 120 dB.

Common-Mode Voltage (CMV) A term used in regard to operational amplifiers to describe the signals applied to the inverting and noninverting inputs that are equal in magnitude and in phase.

Communications Processor A CPU dedicated to perform primarily communications functions. Computers performing in this role may be used as a link between large general-purpose computers and communications facilities to improve general data processing efficiency.

Comparator A device that produces outputs that show whether one input is greater than, equal to, or less than the other input. Both analog and digital comparators exist.

Compensation Provision of a supplemental device, circuit, or special materials to counteract known sources of error.

Compiler A program that converts a program in a high-level or procedure-oriented language into an assembly or machine language program.

Condition Code (or flag) A single bit that indicates a condition within the computer, often used to choose between alternate instruction sequences.

Contact Closure Type of output from equipment referring to relay outputs.

Contact Sense Type of input to equipment referring to relay or switch contacts.

Condition Code Register A register that contains one or more condition codes.

Control Memory A memory that holds microprograms--that is, a memory used to decode computer instructions.

Core Memory A magnetic memory that can be magnetized in one of two directions so as to represent a bit of data.

Counter A clocked device that enters a different state after each clock pulse (up to its capacity), and

produces an output that reflects the total number of clock pulses it has received. Counters are also referred to as dividers, since they divide the input frequency by n , where n is the capacity of the counter.

Critical Damping See Damping.

Cross-Assembler An assembler that runs on a computer other than the one for which it assembles programs.

Cross-Axis Acceleration See Transverse acceleration.

Cross Sensitivity Cross-Axis Sensitivity - See Transverse Sensitivity.

CRT See Cathode-ray tube.

Current-Loop Interface (or Teletype Interface) An interface that permits connections between digital logic and a device that uses current-loop signals--that is, typically the presence of 20 mA in the loop is a logic one and the absence of that current is a logic zero.

Cycle Stealing Using a cycle during which the CPU is not accessing the memory for a DMA operation.

Cycle Time Time interval at which a set of operations is repeated regularly in the same sequence.

CRC Cyclic Redundancy Check. An error-detecting code generated from a polynomial that can be added to a data record or sector.

Daisy Chain An input or output method whereby signals pass from one device to another until accepted or blocked. Activity near the control unit for the chain blocks activity farther from the control unit.

Damping The energy-dissipating characteristic which, together with natural frequency, determines the limit of frequency response and the response-time characteristics of a transducer

Damping Ratio The ratio of actual damping to the magnitude of critical damping.

Data Information or facts represented in some formalized way, typically digitally for storage or processing.

Data Access Arrangement An interface designed to isolate the telephone network from the undesirable effects of the following conditions: Unsafe voltages; Frequency Variations; Excessive Amplitude; Incorrect Line Balance.

Data Acquisition System A system that accepts several analog inputs and produces corresponding digital data. The system usually includes sample and hold circuitry, multiplexers, and converters.

Data Concentrator Assembles low-speed bits (baud rates) into characters and blocks, and frequently performs a code translation and/or a compression of the data. The net effect is a translation of the original group of signals into a composite signal that contains substantially more information per unit of time.

Data Fetch Cycle A computer operation cycle during which data are brought from memory to the CPU.

Data Logger An integrated, stand-alone data acquisition system which usually has built-in signal conditioning for thermocouples, RTDs, and strain gages. It has the ability to acquire input data from a few to several hundred channels, record and print the data, and generate alarm and display outputs. Data processing or calculation ability is minimal.

Data Pointer (or Pointer) A register or memory location that holds an address rather than the data themselves.

Data Rate The rate at which a channel can carry data, measured in bps or baud.

Data Set See Modem.

Data Set Ready An interface signal generated by a modem to indicate that power is applied and that the modem is connected to the communications circuit.

Data Terminal Ready An interface signal produced by the Data Communications Device (data terminal or CPU) to indicate operational readiness.

Debounce Convert the output from a contact with bounce into a single, clean transition between states.

Debounce Time The amount of time required to debounce a closure.

Debug To eliminate programming errors, sometimes referred to as verifying the program.

Debugger (or Debug Program) A program that helps in finding and correcting errors in a user program.

Decade Counter A counter with ten different states.

Decimal Adjust An operation that converts a binary arithmetic result to a decimal (BCD) result.

Decoder A device that produces unencoded outputs from coded inputs.

Dedicated Lines Private lines used for special purposes, such as data communications. Dedicated lines are idle when not used by designated subscribers; therefore, immediate access is provided.

Delay Time The amount of time between the clocking signal and the actual appearance of output data, or the time between input and output.

Demodulation The process of extracting information from a previously modulated carrier frequency having substantially the same characteristics of the original modulating signal.

Demultiplexer A device that directs time-shared input to one of several possible outputs, according to the state of the select inputs.

Destructive Readout (DRO) The contents cannot be determined without changing them.

Development System A special computer system that includes hardware and software specifically designed for developing programs and interfaces.

Diagnostic (Program) A program that checks part of a system for proper operation.

Differential-Mode Signal Amplifier input terminals have potentials on them with respect to common or earth ground. The difference in these two potentials is the differential-mode signal. (This is also referred to as the Normal-Mode Signal).

Digital Having discrete levels, quantized into a series of distinct levels.

Digital Output Transducer output that represents the magnitude of the measurand in the form of a series of discrete quantities coded in a system of notation. Distinguished from analog output.

Direct Addressing An addressing method whereby the address of the operand is part of the instruction.

Directly Addressable Can be addressed without changing the contents of any registers or bank switches.

Direct Execution A method whereby the computer directly executes statements in a high-level language rather than translating those statements into machine or assembly language.

Direct Memory Access (DMA) An input/output method whereby an external controller directly transfers data between the memory and input/output sections without processor intervention.

Disable Prohibit an activity from proceeding or a device from producing data outputs.

Disk Operating System (DOS) An operating system that transfers programs and data to and from a disk, which may be either flexible or fixed-head; the operating system may itself be largely resident on disk.

Double Amplitude The peak-to-peak value.

Dual In-Line Package (DIP or Bug) A semiconductor chip package having two rows of pins perpendicular to the edges of the package, sometimes called a bug, since it appears to have legs.

Dual Port Two separate access paths to and from one unit.

Duplex Circuit A circuit which will permit transmission in both directions.

Drift An undesired change in output over a period of time; a change which is not a function of the measurand.

Dynamic Characteristics Characteristics of a transducer which relate to its response to variations of the measurand with time.

Dynamic Memory A memory that loses its contents gradually without any external causes.

EAROM Electrically alterable ROM, a nonvolatile RAM, often with a relatively long write time.

EBCDIC Expanded Binary-Coded Decimal Interchange Code, an 8-bit character code often used in large computers.

Echo The process of repeating an original message and returning it to the sending terminal for verification or test.

ECL Emitter-coupled logic; a high-speed bipolar technology often used in computer mainframes.

Editor A program that manipulates text material and allows the user to make corrections, additions, deletions, and other changes.

EIA Interface An interface between a data terminal and a modem, across which signals are exchanged as specified by the Electronic Industries Association.

EMF Electromotive Force.

EMI Electromagnetic Interference.

Emulator A microprogrammed copy of an existing system.

Enable Allow an activity to proceed or a device to produce data outputs.

Encoder A device that produces coded outputs from unencoded inputs.

End Points The outputs at the specified upper and lower limits of the range. Unless otherwise specified, end points are averaged during any one calibration.

Environmental Conditions Specified external conditions (shock, vibration, temperature, etc.) to which a transducer may be exposed during shipping, storage, handling and operation.

Environmental Conditions, Operating Environmental conditions during exposure to which a transducer must perform in some specified manner.

EPROM (or EROM) Erasable PROM, a PROM that can be completely erased by exposure to ultraviolet light.

Error The algebraic difference between the indicated value and the true value of the measurand. It is usually expressed in percent of the full-scale output, sometimes expressed in percent of the output reading of the transducer. A theoretical value may be specified as true value.

Error-Correcting Code A code that can be used by the receiver to correct errors in the messages to which the code is attached; the code itself does not contain any additional message.

Error Curve A graphical representation of errors obtained from a specified number of calibration cycles.

Excitation The external electrical voltage and/or current applied to a transducer for its proper operation.

Failover Hardware design feature. When an error is detected, the system automatically switches to backup hardware.

Fan-In The number of inputs connected to a gate.

FCC Federal Communications Commission.

FFT Fast Fourier Transform.

Firmware Microprograms, usually implemented in read-only memories (ROMs).

Flatpack A semiconductor chip package in which the pins are in the same plane as the package rather than perpendicular to it as in a DIP.

Flip-Flop A digital electronic device with two stable states that can be made to switch from one state to the other in a reproducible manner.

Floating Not tied to any logic level, often applied to tri-state outputs that are in the high-impedance state. TTL devices usually interpret a floating input as a logic one.

Floppy Disk (or Flexible Disk) A flexible magnetic surface that can be used as a data storage device; the surface is divided into sectors. An IBM-compatible floppy disk is one that uses formatting and sectoring techniques originally introduced by IBM. The individual floppy disk is sometimes called a diskette.

Flowchart A graphical representation of a procedure or computer program.

FM Frequency modulation. A type of modulation in which the frequency of the carrier is altered in sympathy with the information signal.

FORTRAN (Formula Translation language, A high-level (procedure-oriented) programming language devised for expressing scientific problems in algebraic notation.

FR Full Range.

Frequency, Natural The frequency of free (not forced) oscillations of the sensing element of a fully assembled transducer. It is also defined as the frequency of a sinusoidally applied measurand at which the transducer output lags the measurand by 90 degrees.

Frequency, Resonant The measurand frequency at which a transducer responds with maximum output amplitude.

Frequency Response The change with frequency of the output measurand amplitude ratio (and of the phase difference between output and measurand), for a sinusoidally varying measurand applied to a transducer within a stated range of measurand frequencies.

Front End The data acquisition unit in a computer based data acquisition and control system. It performs signal conditioning, amplification, multiplexing and digitization of analog voltages from transducers, gages, sensors, etc.

FS Full Scale.

Full-Duplex A transmission channel which can carry signals in both direction simultaneously.

Full-Scale Output The algebraic difference between the end points. Sometimes expressed as "± (one-half the algebraic difference)" e.g., "±2.5 volts."

Gage Factor A measure of the ratio of the relative change of resistance to the relative change in length of a resistive strain transducer (strain gage).

Gain The ratio of output voltage, current, or power to the input voltage, current, or power, respectively, in an amplifier. Gain is usually expressed in dB.

Gate A digital logic element where the binary value of the output depends on the values of the inputs according to some logic rule.

General Purpose Interface Bus (GPIB or Hewlett-Packard interface bus) A standard interface for the transmission of parallel data in a network of instruments. The GPIB has eight data lines, eight control lines, and eight ground lines.

General Purpose Register A register that can be used for temporary data storage.

GOES Geostationary Operational Environmental Satellites.

GPIB General Purpose Interface Bus.

Gray Code A binary code sequence in which only one bit changes in a transition to the next higher or lower value.

Half-Carry Bit (or Auxiliary Carry) A status bit that is one if the last operation produced a carry from bit 3 of an 8-bit word. Used on 8-bit microprocessors to make the correction between binary and decimal (BCD) arithmetic.

Half-Duplex A transmission channel which can carry signals in either direction but not simultaneously.

Handshaking The establishment of a link by an initial exchange of control signals, between devices, that verifies that the data exchange can proceed.

Hardware Physical equipment forming a computer system.

Hexadecimal Number system with base 16. The digits are the decimal numbers 0 through 9, followed by the letters A through F.

High-Level Language (or Procedure-Oriented language) A programming language in which the statements represent procedures rather than single machine instructions. FORTRAN, COBOL, and BASIC are three common high-level languages. A high-level lang-

uage requires a compiler that translates each statement into a series of machine language instructions.

High-Level Protocol A protocol which handles functions at a higher level than merely carrying data, for example, FTP.

Hysteresis The maximum difference in output, at any measurand value within the specified range, when the value is approached first with increasing and then with decreasing measurand.

Icon Pictorial representation.

IEEE Standard 488 Bus See General Purpose Interface Bus.

IF Intermediate Frequency (telemetry).

Immediate Addressing An addressing method in which the operand is part of the instruction itself.

Immediate Data Data that are a part of the instruction that uses them.

Implied Addressing (or Inherent Addressing) The operation code itself specifies all the required addresses.

Impulse Noise Interference on a communications circuit, in the form of high-level, short-duration spikes. Noise of this type often occurs in bursts and can cause data errors.

In-Circuit Emulator A device that allows a prototype to be attached to a development system for testing and debugging purposes

Index Register A register that can be used to modify memory addresses.

Indexed Addressing An addressing method in which the address included in the instruction is modified by the contents of an index register in order to find the actual address of the data.

Indirect Addressing An addressing method in which the address of the data, rather than the data themselves, is in the memory location specified by the instruction.

Input Bias Current The average current flowing into the amplifier input terminals when the output is at zero voltage.

Input Impedance The impedance (presented to the excitation source) measured across the excitation terminals of a transducer.

Input/Output (Section) The section of the computer that handles communications with external devices.

Instruction A group of bits that defines a computer operation and is part of the instruction set.

Instruction Cycle The process of fetching, decoding, and executing an instruction.

Instruction Execution The process of performing the operations indicated by an instruction.

Instruction (Execution) Time The time required to fetch, decode, and execute an instruction.

Instruction Fetch The process of addressing memory and reading an instruction word into the CPU for decoding.

Instruction Length The number of words of memory needed to store a complete instruction.

Instruction Repertoire See Instruction set.

Instruction Set The set of general-purpose instructions available with a given computer--that is, the set of inputs to which the CPU produces a known response during the instruction fetch cycle.

Integrated Circuit (IC) A complete circuit on a single substrate or chip.

Intelligent Terminal (or Smart Terminal) A terminal that has some data processing capability or local computing capability.

Interface A boundary, either in hardware or software, across which the interaction of two processes is defined.

Interpreter A program that fetches and executes instructions written in a high-level language. An interpreter executes each instruction as soon as it reads the instruction; it does not produce an object program, as a computer does.

Interrupt A computer input that temporarily suspends the normal sequence of operations and transfers control to a special routine.

Interrupt-Driven System A system that depends on interrupts to handle input and output or that idles until it receives an interrupt.

Interrupt Mask (or Interrupt Enable) A mechanism that allows the program to specify whether interrupts will be accepted.

Interrupt Service Routine A program that performs the actions required to respond to an interrupt.

Inverter A logic device that complements the input.

I/O Input/Output.

IOP Input/Output Port.

IPB Illustrated Parts Breakdown.

IR-drop The voltage equal to the product of the current passing through a resistor and its resistance.

Isolated Input/Output An addressing method for I/O ports that uses an addressing system distinct from that used by the memory section.

Jump Instruction An instruction that places a new value in the program counter, thus departing from the normal one-step incrementing. Jump instructions may be conditional; that is, the new value may only be placed in the program counter if certain conditions are met.

Jump Table A table that contains the addresses of routines to which the computer can transfer control.

Keyboard A collection of key switches.

Keyboard Encoder A device that produces a unique output code for each possible closure on a keyboard.

Keyboard Scan The process of examining the rows and columns of a matrix keyboard to determine which keys have been pressed.

Kilobit (kbit) 1000 bits.

Kilobyte (KB) 1000 bytes.

Label A name attached to a particular instruction or statement in a program that identifies the

location in memory of the object code or assignment produced from that instruction or statement.

- LAN** Local Area Network.
- Large-Scale Integration (LSI)** An integrated circuit with complexity equivalent to over 100 ordinary gates.
- Latch** A temporary storage device controlled by a timing signal. The contents of the latch are fixed at their current values by a transition of the timing signal (clock) and remain fixed until the next transition.
- Least-Squares Line** The straight line for which the sum of the squares of the residuals (deviations) is minimized.
- Least-Squares Linearity** See Linearity, Least Squares.
- Light-Emitting Diode (LED)** A semiconductor device that emits light when biased in the forward direction.
- Line** A communications path.
- Line Adapter** See Data Access Arrangement.
- Line Dropout** A significant loss of amplitude in signals applied to a communications line; normally a transient occurrence that can induce errors.
- Linear Select** Using coded bus lines individually for selection purposes rather than decoding the lines. Linear select requires no decoders but allows only n separate devices to be connected rather than 2^n , where n is the number of lines.
- Linearity** The closeness of a calibration curve to a specified straight line.
- Linearity, End Point** Linearity referred to the end-point line.
- Linearity, Least Squares** Linearity referred to the least-squares line.
- Linking Loader** A loader that will enter a series of programs and subroutines into memory and provide the required interconnections.
- Loader** A program that reads a user or system program from an input device into memory

Load Impedance The impedance presented to the output terminals of a transducer by the associated external circuitry.

Logic Analyzer A test instrument that detects and displays the state of parallel digital signals.

Logic Design Design using digital logic circuits.

Logical Shift A shift operation that places zeroes in the empty bits.

Logical Sum A bit-by-bit EXCLUSIVE-ORing of two binary numbers.

Lookahead Carry A device that forms the carry bit from a binary addition without using the carries from each bit position.

Loop A self-contained sequence of instructions that the processor repeats until a terminal condition is reached. A conditional jump instruction can determine if the loop should be continued or terminated.

Low-Level Language A language in which each statement is directly translated into a single machine language instruction. See Assembly Language and Machine Language.

LRC Longitudinal redundancy check, an error-detecting character sequence formed by taking the parity of each row of bits from 2^0 to 2^6 in a message.

LRCC Longitudinal Redundancy Correction Code.

LVDT Linear Variable Differential Transformer.

mA Milli-amperes.

Machine Cycle The basic CPU cycle. One machine cycle is the time required to fetch data from memory or execute a single-word operation.

Machine Language The programming language that the computer can directly understand with no translation other than numeric conversions. A machine language program can be loaded into memory and executed. The value of every bit in every instruction in the program must be specified.

Macro A name that represents a sequence of instructions. The assembler replaces a reference to the macro with a copy of the sequence.

Macrosssembler An assembler that has facilities for macros.

Macroinstruction An overall computer instruction fetched from the main memory in a microprogrammed computer.

Mainframe An enclosure that contains the Central Processor(s), main memory, and any other integral controllers or devices.

Mark The binary one condition. A mark is produced by a voltage more negative than -3 volts in the RS-232-C Channel, or when current flows in a TTY current-loop connection.

Maskable Interrupt An interrupt that the system can disable.

Matrix Keyboard A keyboard in which the keys are connected in rows and columns.

Maximum (Minimum) Ambient Temperature The value of the highest (lowest) ambient temperature to which a transducer can be exposed, with or without excitation applied, without being damaged or subsequently showing a performance degradation beyond specified tolerances.

Maximum Excitation The maximum value of excitation voltage or current that can be applied to the transducer at room conditions without causing damage or performance degradation beyond specified tolerances.

MB Megabyte (one million bytes).

Measurand A physical quantity, property or condition which is measured.

Medium-Scale Integration (MSI) An integrated circuit with a complexity of between 10 and 100 gates.

Megabit (Mbit) One million bits.

Memory (Section) The section of a computer that serves as storage for data and instructions. Each item in the memory has a unique address that the CPU can use to fetch it.

Memory Address Register (or Storage Address Register) A register that holds the address of the memory location being accessed.

Memory-Mapped Input/Output An addressing method for I/O ports that uses the same addressing system as that used by the memory section.

Message A group of words representing a complete informational unit. A message usually includes a header, a text made of one data block or more, and an EOM indication.

Metrology The science of measurement for determination of conformance to technical requirements including the development of standards and systems for absolute and relative measurements. (Test Equipment)

Microassembler An assembler specifically designed for writing microprograms.

Microcomputer A computer whose CPU is a microprocessor. A microprocessor plus memory and input/output circuitry.

Microcontroller A microprogrammed control system without arithmetic capabilities.

Microprocessor The central processing unit (CPU) of a small computer, implemented on one or a few LSI chips.

Microprocessor Analyzer A piece of test equipment that can be used to trace and debug the operations of a microprocessor.

Microprogram A program written at the control level and stored in a control memory.

Microprogrammable Having a microprogrammed control function that the user can change. That is, the user can add, enter, or replace microprograms.

Microprogrammed Having the control function implemented through microprogramming.

Microprogramming The implementation of the control function of a processing system as a sequence of control signals that is organized into words and stored in a control memory.

Mnemonics Symbolic names or abbreviations for instructions, registers, memory locations, etc., which suggest their actual functions or purposes.

Modem Modulator/demodulator, a device that adds or removes a carrier frequency, thereby allowing data to be transmitted on a high-frequency channel or received from such a channel.

Modular Programming A programming method whereby the entire task is divided into logically separate sections or modules.

Modulation The process of altering some characteristic of a carrier wave in sympathy with an information signal.

Monitor A simple operating system that allows the user to enter or change programs and data, to run programs, and to observe the status of the various section of the computer.

Monostable Multivibrator (or One-Shot) A device that produces a single pulse of known length in response to a pulse input.

MOS Metal-oxide semiconductor, a semiconductor process that uses field-effect transistors in which the current is controlled by the electric field around a gate.

Mounting Error The error resulting from mechanical deformation of the transducer caused by mounting the transducer and making all measurand and electrical connections.

MTBF Mean Time Between Failures.

Multiplexer (or Selector) (MUX) A device that selects one of several possible inputs to be placed on a time-shared output bus according to the state of the select inputs.

Multidrop line A leased line with several connections along its length.

Multipoint Circuit A contention communications system consisting of several communications channels.

Multiprocessing Using two or more processors in a single system, operating out of a common memory.

MUX Multiplexer.

mV Millivolts.

Natural Frequency See Frequency, Natural.

Negative Logic Circuitry in which a logic zero is the active or ON state.

Nesting Constructing subroutines or interrupt service routines so that one transfers control to another and so on. The nesting level is the number of transfers required to reach a particular routine without returning.

Nibble A sequence of four bits operated on as a unit.

NLQ Near Letter Quality.

NMOS N-channel metal-oxide semiconductor, a logic family that uses N-channel MOS field-effect transistors to provide high density and medium speed.

Node A junction between two or more lines in a network. In a packet switched system it refers to a switching processor.

Noise Margin The noise voltage required to make logic circuits malfunction.

Nonmaskable Interrupt An interrupt that the system cannot disable.

Nonvolatile Memory A memory that does not lose its contents when power is removed.

No-Op (or No Operation) An instruction that does nothing other than increment the program counter.

Null A condition, such as of balance, which results in a minimum absolute value of output.

Object Program (or Object Code) The program that is the output of a translator program, such as an assembler or compiler. Usually a machine language program ready for execution.

Octal Number system with base 8. The digits are the decimal numbers 0 through 7.

Offset A number that is to be added to another number to calculate an effective address.

One-Address Instruction An instruction in which only one data address must be specified. The other data, if necessary, are presumed to be in the accumulator.

One's Complement A bit-by-bit logical complement of a binary number.

One-Shot See Monostable Multivibrator.

On-Line System A computer system in which information reflecting current activity is introduced as soon as it occurs.

Open-Collector Output A special output that is active-low but not high. Such outputs can be wired-ORed to form a bus employing negative logic.

Operating System System software that controls the overall operation of a computer system and performs such tasks as memory allocation, input and output distribution, interrupt processing and job scheduling.

Operation Code (Op Code) The part of an instruction that specifies the operation to be performed during the next cycle.

Optoisolator Semiconductor device consisting of an LED and a photodiode or phototransistor in close proximity. Current through the LED causes internal light emission that forces current to flow in the phototransistor. Voltage differences have no effect because the devices are electrically separated.

Output The electrical quantity, produced by a transducer, which is a function of the applied measurand.

Output Impedance The impedance across the output terminals of a transducer presented by the transducer to the associated external circuitry.

Output Noise The rms, peak, or peak-to-peak (as specified) AC component of a transducer's DC output in the absence of measurand variations.

Output Regulation The change in output due to a change in excitation.

| | |
|---------------------|--|
| Overflow Bit | A status bit that is one if the last operation produced a two's complement overflow. |
| Overlay | The section of a program that is actually resident in memory at a particular time. A large program can be divided into overlays and run on a computer having limited memory but backup storage for the the rest of the program. |
| Overload | The maximum magnitude of measurand that can be applied to a transducer without causing a change in performance beyond specified tolerance. |
| Overrange | See Overload. |
| Page | A subdivision of the memory section. |
| Page Zero | The first page of memory; the most significant address bits (or page number) are zero. |
| Parallel | More than one bit at a time. |
| Parity | A 1-bit code that makes the total number of one bits in the word, including parity bit, odd (odd parity) or even (even parity). |
| Parity Bit | A status bit that is one if the last operation produced a result with even (if even parity) or odd (if odd parity) parity. |
| Pascal | Programming language. |
| PC | Printed Circuit or Personal Computer. |
| PID | Proportional Integral and Differential. |
| PL/I | Programming Language I, a high-level language developed by IBM that combines many of the features of earlier languages, such as ALGOL, COBOL, and FORTRAN. Many versions exist for microprocessors, such as PL/M, MPL, SM/PL, and PLmicroS (PLuS). |
| PM | Preventive Maintenance. |
| PMOS | P-channel metal-oxide semiconductor, a logic family that uses P-channel MOS field-effect transistors to provide high density and low speed. |
| Pointer | Register or memory location that contains an address rather than data. |

Polling Determining the state of peripherals or other devices by examining each one in succession.

Pop (or Pull) Remove an operand from a stack.

Port The basic addressable unit of the computer input/output section.

Power-On Reset A circuit that automatically causes a RESET signal when the power is turned on, thus starting the system in a known state.

Printed Circuit Board (PC Board) A circuit board on which the connections are made by etching with a mask.

Priority Interrupt System An interrupt system in which some interrupts have precedence over others--that is, will be serviced first or can interrupt the others' service routines.

Private Line A dedicated line set aside for private use, normally leased exclusively to one subscriber.

Process Control Current Type of analog transmission, 4-20 mA or 10-50 mA.

Program A sequence of instructions properly ordered to perform a particular task.

Program Counter A register that specifies the address of the next instruction to be fetched from program memory.

Program Library A collection of debugged and documented programs.

Programmable Interface An interface device that can have its active logic structure varied under program control.

Programmable Logic Array (PLA) An array of logic elements that can be programmed to perform a specific logic function; like a ROM except that only certain addresses are decoded.

Programmable Timer A device that can provide various timing modes and intervals under program control.

Programmed Input/Output (I/O) Input/output performed under program control without using interrupts or direct memory access.

PROM Programmable read-only memory, a memory that cannot be changed during normal operation but that can be programmed by the user under special conditions. The programming is generally not reversible.

Protocol A definition of what data and when they may be sent across an interface.

Pseudo-Operation (or Pseudo-Instruction) An assembly language operation code that directs the assembler to perform some action but does not result in a machine language instruction.

Pull See Pop.

Pullup Resistor A resistor connected to the power supply that ensures that an otherwise open circuit will be at the voltage level of the power supply.

Pulse Generator A device that produces a single pulse or a series of pulses of predetermined length in response to an input signal.

Push Enter an operand into a stack.

Q-bus Input/output bus for Digital Equipment Corporation microcomputer.

Queue (or FIFO) A set of registers or memory locations that are accessed in a first-in, first-out manner. That is, the first data entered into the queue is the first data read.

RAM Random-access memory (read/write). A memory that can be both read and altered (written) in normal operation.

Random Access All internal storage locations can be accessed in the same amount of time.

Range The measurand values, over which a transducer is intended to measure, specified by their upper and lower limits.

Rcal Resistance Calibration. Done by substituting a known resistance for an unknown resistance.

Real Time In synchronization with the actual occurrence of events.

Real-Time Clock A device that interrupts a CPU at regular time intervals.

Recursive Subroutine A subroutine that calls itself as part of its execution.

Reentrant Subroutine A subroutine that can be executed correctly even while the same routine is being interrupted or otherwise held in abeyance.

Reference Pressure The pressure relative to which a differential-pressure transducer measures pressure.

Reference-Pressure Error The error resulting from variations of a differential-pressure transducer's reference pressure within the applicable reference pressure range.

Reference-Pressure Range The range of reference pressures which can be applied without changing the differential-pressure transducer's performance beyond specified tolerances for reference pressure error. When no such error is specified, none is allowed.

Reference-Pressure Sensitivity Shift The sensitivity shift resulting from variations of the reference pressure of a differential-pressure transducer within specified limits.

Reference-Pressure Zero Shift The change in the zero-measurand output of a differential-pressure transducer resulting from variations of reference pressure (applied simultaneously to both pressure ports) within its specific limits.

Refresh The process of restoring the contents of a dynamic memory before they are lost.

Register A storage location used to hold bits or words inside the CPU.

Register Direct Addressing An addressing method that is the same as direct addressing except that the address is a register rather than a memory location.

Register Indirect Addressing An addressing method that is the same as indirect addressing except that the address is in a register rather than in a memory location.

Relative Addressing An addressing method in which the address specified in the instruction is the offset from a base address. The base address may be the contents of the program counter or a base register. Relative addressing allows programs to be easily relocated in memory.

Relocatable Can be placed in any part of memory without changes--that is, a program that can occupy any set of consecutive memory addresses.

Remote Terminal A terminal isolated from the controller output by some electronic buffer, usually a modem.

Repeatability The ability of a transducer to reproduce output readings when the same measurand value is applied to it consecutively, under the same conditions, and in the same direction.

Reset A signal that starts a system in a known state.

Resident Software Software that can run on the computer itself, unlike cross-assemblers or cross-compilers, which must run on another computer.

Resolution The input increment that gives the smallest measurable change in output.

Request-To-Send An interface signal produced by the communications device as an indication of readiness to transmit data to the modem. Clear-to-Send is the response to the Request-to-Send signal.

RF Radio Frequency.

Ripple Carry Forming the carry bit from a binary addition by using the carries from each bit position.

ROM Read-only memory, a memory that contains a fixed pattern of data permanently defined as part of the manufacturing process.

Routine A program or subprogram.

RS Flip-Flop A flip-flop that can be placed in the 1 state by a signal on the SET input, or in the 0 state by a signal on the RESET input.

RS-232-C The Electronic Industries Association (EIA) standard interface for the transmission of serial digital data.

RTD Resistance Temperature Device.

REE Real-time Executive.

RTU Remote Terminal Unit.

Schmitt Trigger A circuit used to produce a single, sharp transition, i.e., pulse, from a slowly changing input.

Schottky TTL A high-speed variant of standard transistor-transistor logic (TTL).

Scratch-Pad Memory Memory locations or registers that are used to store temporary or intermediate results.

Self-Assembler An assembler that runs on the computer for which it assembles programs.

Self-Checking Number A number in which some of the digits serve to check for possible errors in the other digits and do not contain any additional information.

Self-Test A procedure whereby a system checks the correctness of its own operation.

Sensing Element The part of the transducer which responds directly to the measurand.

Sensitivity The ratio of the change in transducer output to a change in the value of the measurand.

Sensitivity Shift A change in the slope of the calibration curve due to a change in sensitivity.

Serial One bit at a time.

Serial-Access A storage device (such as a magnetic tape) from which data may only be reached or retrieved by passing through all intermediate locations between the desired one and the currently available one.

Set Make state a logic one.

Seven-Segment Code The code required to represent decimal digits or other characters on a seven-segment display.

Seven-Segment Display A display made up of seven separately controlled elements that can represent decimal digits or other characters.

Shift Register A clocked device that moves its contents one bit to the left or right during each clock cycle.

Sign Bit The most significant bit of a register or memory location; a status bit that is one if the most significant bit of the result of the previous operation was one.

Sign Extension The result of a right arithmetic shift that copies the sign bit into the succeeding less significant bits.

Signal The physical form of some information transfer may be voltage or current waves, light in an optical fiber, etc.

Signal Conditioning Making a signal compatible with the input requirements of a particular device through buffering, level translation, amplification, etc.

Sink Current The ability of a device to accept current from external loads.

Small-Scale Integration (SSI) An integrated circuit with a complexity of ten gates or less.

SOS Silicon-on-sapphire, a faster MOS technology that uses an insulating sapphire substrate.

Source Impedance The impedance of the excitation supply presented to the excitation terminals of the transducer.

Source Program Computer program written in an assembly or high-level language.

Span The algebraic difference between the limits of the range.

Space The zero state on a serial data communications line.

SPDT Switch Single-pole, double-throw switch with one common line and two output lines.

SPST Switch Single-pole, single-throw switch with one common line and one output line.

Stability The ability of a transducer to retain its performance characteristics for a relatively long period of time.

Stack A sequence of registers or memory locations that are used in a last-in, first-out manner--that is, the last data entered are the first to be removed and vice versa.

Stack Addressing An addressing method whereby the data to be used are in a stack.

Stack Pointer A register or memory location that is used to address a stack.

Stand-Alone System A computer system that does not require a connection to another computer.

Standard Teletypewriter A teletypewriter that operates asynchronously at a rate of ten characters per second.

Standby Power (or Quiescent Power) The amount of power required to maintain the contents of a volatile memory when it is not being accessed.

Start Bit A one-bit signal that indicates the start of data transmission by an asynchronous device.

State Counter A counter that contains the number of states that have occurred in the current operation.

Static Calibration A calibration in which the standard measurand value applied to the sensor is not changing, i.e., static.

Static Memory A memory that does not change its contents without external causes, opposite of dynamic memory.

Status Register (or Status Word) A register whose contents reflect the current status of the computer; may be the same as condition code register.

Stop Bit A one-bit signal that indicates the end of data transmission by an asynchronous device.

Strobe A one-bit signal that identifies or describes another set of signals and that can be used to clock or enable a register.

Structured Programming A programming method whereby all programs consist of structures from a limited but complete set; each structure should have a single entry and a single exit.

Subroutine A subprogram that can be reached from more than one place in a main program. The process of passing control from the main program to a subroutine is a Subroutine Call and the mechanism is a Subroutine Linkage. The data and addresses that the main program makes available to the subroutine are Parameters, and the process of making them available is call Passing Parameters.

Subroutine Call See Subroutine.

Synchro-To-Digital Converter A device that converts an analog angle to a corresponding digital value.

Synchronous Operation Operating according to an overall timing source, i.e., at regular intervals.

Synchronization Making two signals operate according to the same clocking signal.

Syntax The rules governing a sentence or statement structure in a language.

T/C Thermocouple.

TEB Total Error Band.

Teleprinter See Teletypewriter.

Teletypewriter A device containing a keyboard and a serial printer that is often used in communications and with computers.

Temperature Error Band The error band applicable over stated environmental temperature limits.

Temperature Gradient Error The transient deviation in output of a transducer at a given measurand value when the ambient temperature or the measured fluid temperature changes at a specified rate between specified magnitudes.

Temperature Range, Operating The range of ambient temperatures, given by their extremes, within which the transducer is intended to operate. Within this range of ambient temperature, all tolerances specified for temperature error, temperature error band, temperature gradient curve error, thermal zero shift, and thermal sensitivity shift are applicable.

Terminal An input/output device at which data enters or leaves a computer system.

Theoretical Curve The specified relationship (table, graph, or equation) of the transducer output to the applied measurand over the range.

Theoretical slope The straight line between the theoretical end points.

Thermal Coefficient of Resistance The relative change in resistance of a conductor or semiconductor per unit change in temperature over a stated range of temperature. Expressed in ohms per ohm per degree F or C.

Thermal Sensitivity Shift The sensitivity shift due to changes of the ambient temperature from room temperature to the specified limits of the operating temperature range.

Thermal Zero Shift The zero shift due to changes of the ambient temperature from room temperature to the specified limits of the operating temperature range.

Threshold The smallest change in the measurand that will result in a measurable change in transducer output. When the threshold is influenced by the measurand values, these values must be specified.

Time-Shared Bus A bus that is used for different purposes at different times.

Top-Down Design A design method whereby the overall structure is designed first and parts of the structure are subsequently defined in greater detail.

TPI Tracks per Inch.

Transducer A device which provides a usable output in response to a specified measurand.

Transverse Acceleration An acceleration perpendicular to the sensitive axis of the transducer.

Transverse Sensitivity The sensitivity of a transducer to transverse acceleration or other transverse measurand.

Trap An instruction that forces a program to jump to a specific address, often used to produce breakpoints or to indicate hardware or software errors.

Tri-State (or Three-State) Logic outputs with three possible states--high, low, and an inactive (high-impedance or open-circuit) state that can be combined with other similar outputs in a busing structure.

Tri-State Enable (or Select) An input that, if not active, forces the outputs of a tri-state device into the inactive or open-circuit state.

TTL (Transistor-Transistor Logic) The most widely used bipolar technology for digital integrated circuits. Popular variants include high-speed Schottky TTL and low-power Schottky (or LS) TTL.

TTL Compatible Uses voltage levels that are within the range of TTL devices and can be used with TTL devices without level shifting, although buffering may be necessary.

Turnkey System A complete system designed, developed, installed, and made operational, usually under control of a single vendor.

Two's Complement A binary number that, when added to the original number in a binary adder, produces a zero result. The two's complement is the one's complement plus one.

Two's Complement Overflow A situation in which a signed arithmetic operation produces a result that cannot be represented correctly--that is, the magnitude overflows into the sign bit.

UHF Ultra High Frequency.

Unibus Input/output bus for Digital Equipment Corporation minicomputer.

Universal Asynchronous Receiver/Transmitter (UART) An LSI device that acts as an interface between systems that handle data in parallel and devices that handle data in asynchronous serial form.

Universal Synchronous Receiver/Transmitter (USRT) An LSI device that acts as an interface between systems that handle data in parallel and devices that handle data in synchronous serial form.

Utility Program A program that provides basic functions, such as loading and saving programs, initiating program execution, observing and changing the contents of memory locations, or setting breakpoints and tracing.

VCO Voltage Controlled Oscillator.

VHF Very High Frequency.

Vibration Error The maximum change in output, at any measurand value within the specified range, when vibration levels of specified amplitude and range of frequencies are applied to the transducer along specified axes.

Virtual Call A virtual circuit set up at user request when it is needed and terminated when no longer needed, analogous with a dial-up line.

Volatile Memory A memory that loses its contents when power is removed.

Warm-Up Period The period of time, starting with the application of excitation to the transducer, required to assure that the transducer will perform within all specified tolerances.

Wideband Channel A channel wider in bandwidth than a standard voice grade telephone channel.

Wired-OR Connecting outputs together without gates to form a busing structure; requires special outputs of which only one is active at a time.

Word The basic grouping of bits that the computer can manipulate in a single cycle.

Word Length The number of bits in the computer word, usually the length of the computer's data bus, and data and instruction registers.

X-series CCITT recommendations for new data networks, for example, X.25 for packet switched networks.

Zero Bit A status bit that is one if the last operation produced a zero result.

Zero-Measurand Output The output of a transducer, under room conditions unless otherwise specified, with nominal excitation and zero measurand applied.

Zero Shift A change in the zero-measurand output over a specified period of time and at room conditions.

REFERENCES

1. Doebelin, E.O., Measurement Systems: Application and Design, McGraw Hill, New York, 1966, p. 502.
2. Ibid, p. 41.
3. Ibid, Fig. 1, p. 10.
4. Ibid, p. 59.
5. SAE Subcommittee on Reliability, Reliability Control in Aerospace Equipment Development, The MacMillan Co., New York, 1963, p. 15.
6. Ibid, p. 42.
7. Considine, D.M., Handbook of Applied Instrumentation, McGraw-Hill Book Company, New York, 1964, pp. 11-78.
8. O'Riley, R., "How to Buy Data Acquisition Equipment", I and CS, "Vol 58", "No. 5", May 1985, p. 56.
9. Herceg, E.E., Handbook of Measurement and Control, Shaevitz Engineering, New Jersey, 1983, p. 1-1.
10. Grounding and Noise Reduction Practices for Instrumentation Systems, Xerox Data Systems, El Segundo, CA, 1963, pp.3-9.
11. Ibid (9), p. 14-1.
12. Ibid (9), p. 14-1.
13. Ibid (9), p. 14-2.
14. Sheingold, D.H., Editor, Transducer Interfacing Handbook, Analog Devices, Inc., Norwood, MA, 1980, p. 1.
15. Seippel, R.G., Transducers, Sensors, and Detectors, Reston Publishing Company, Inc., Reston, VA, 1983, p. 69.
16. Ibid, p. 263.
17. Ibid, p. 270.
18. Ibid, p. 273.
19. Ibid (1), p. 611.

20. Morrison, R., Instrumentation Fundamentals and Applications, John Wiley and Sons, New York, 1984, p. 90.
21. Ibid (14), p. 67.
22. Ibid (14), p. 81.
23. Ibid (14), p. 65.
24. Sheingold, D. H., Editor, Analog-Digital Conversion Handbook, Analog Devices, Inc., Norwood, MA, 1972, p. 48.
25. Instrument Technology, Editors of, Instrumentation and Control Systems Engineering Handbook, TAB Books, Blue Ridge Summit, PA, 1978, p. 400.
26. Ibid (20), p. 7.
27. Kennedy, G., Electronic Communications Systems, McGraw-Hill New York, 1970, p. 252.
28. Karp, H.R., Basics of Data Communications, McGraw-Hill, New York, 1976, p. 114.
29. The Communications Handbook, Microdata Corporation, California, 1973, p. 48.
30. Ibid (27), p. 264.
31. Ibid (1), p. 683.
32. Ibid (27), p. 7.
33. National Aeronautics and Space Administration (NASA), Reliability and Quality Assurance Publication, NHB 5300.4(1C), July 1971 Edition, par 1C302, p. 3-1.
34. Ibid, par 1C309, p. 3-4.
35. Ibid, par 1C304, p. 3-3.
36. Ibid, par 1C310, p. 3-6.

SUGGESTED READING LIST

Bateson, R., Introduction to Control System Technology, Charles E. Merrill Publishing Co., Columbus, Ohio, 1973.

Boylestad, R. L., Introduction Circuit Analysis, "4th ed.", Charles E. Merrill Publishing Co., Columbus, Ohio, 1977.

Considine, D. M., Handbook of Applied Instrumentation, McGraw-Hill Book Company, New York, 1964.

Cooper, W. D., Electronic Instrumentation and Measurement Techniques, Prentice-Hall, Inc., Englewood Cliffs, New Jersey, 1970.

Demarco, T., Controlling Software Projects, Yourdon Press, New York, 1982.

Doebelin, E. O., Measurement Systems: Application and Design, McGraw-Hill, New York, 1966.

Evans, M. W., Piazza, P. H., and Dolkas, J. B., Principles of Productive Software Management, John Wiley and Sons, New York, 1983.

Graeme, J. G., Application of Operational Amplifiers, McGraw-Hill Book Company, New York, 1973.

Grounding and Noise Reduction Practices for Instrumentation Systems, Xerox Data Systems, El Segundo, California, 1963.

Herceg, E. E., Handbook of Measurement and Control, Shaevitz Engineering, New Jersey, 1983.

Hnatek, E. R., A User's Handbook of D/A and A/D Converters, John Wiley and Sons, New York, 1976.

Hnatek, E. R., A User's Handbook of Integrated Circuits, John Wiley and Sons, New York, 1973.

Instrument Technology, Editors of, Instrumentation and Control Systems Engineering Handbook, TAB Books, Blue Ridge Summit, Pennsylvania, 1978.

Kantrowitz, P., Kousourou, G., and Zucker, L., Electronic Measurements, Prentice-Hall, Inc., Englewood Cliffs, New Jersey, 1979.

Karp, H. R., Basics of Data Communications, McGraw-Hill, New York, 1976.

- Kennedy, G., Electronic Communications Systems, McGraw-Hill, New York, 1970.
- Kingslake, R. Optical System Design, Academic Press, New York, 1983.
- Lenk, J. D., Handbook of Electronic Communications, Prentice-Hall, Inc., Englewood Cliffs, New Jersey, 1994.
- Leventhal, L. A., Introduction to Microprocessors: Software, Hardware, Programming, Prentice-Hall, Inc., Englewood Cliffs, New Jersey, 1978.
- Malvino, A. P., Electronic Instrumentation Fundamentals, MacGraw-Hill Book Company, New York, 1967.
- Morrison, R., Instrumentation Fundamentals and Applications, John Wiley and Sons, New York, 1984.
- National Aeronautics and Space Administration (NASA), Reliability and Quality Assurance Publication, NHB 5300.4 (1C), July 1971 Edition.
- Newman, D. G., Engineering Economic Analysis, Engineering Press, Inc., San Jose, California, 1980.
- Oliver, B. M., and Cage, J. M., Electronic Measurements and Instrumentation, McGraw-Hill Book Company, New York, 1971.
- O'Riley, R., "How to Buy Data Acquisition Equipment", I and CS, "Vol 58", "No. 5", May 1985.
- Perry, C. C., and Lissner, H. R., The Strain Gage Primer, "2nd ed.", McGraw-Hill Book Company, New York, 1962.
- Precision Measurement and Calibration, Special Publication 300, "Vol 1", U.S. Dept. of Commerce, National Bureau of Standards, 1969.
- SAE Subcommittee on Reliability, Reliability Control in Aerospace Equipment Development, The MacMillan Co., New York, 1963.
- Seippel, R. G., Transducers, Sensors, and Detectors, Reston Publishing Company, Inc., Reston, Virginia, 1983.
- Sheingold, D. H., Editor, Analog-Digital Conversion Handbook, Analog Devices, Inc., Norwood, Massachusetts, 1972.
- Sheingold, D. H., Editor, Transducer Interfacing Handbook, Analog Devices, Inc., Norwood, Massachusetts, 1980.

Stone, H. S., Microcomputer Interfacing, Addison-Wesley Publishing Company, Reading, Massachusetts, 1982.

The Communications Handbook, Microdata Corporation, California, 1973.

Wildi, T., Electrical Power Technology, John Wiley and Sons, New York, 1981.

APPENDIX A: SYSTEM REQUIREMENTS DOCUMENT

SYSTEM REQUIREMENTS DOCUMENT

(Facility)

(Contract)

(System Name)

(System Design Engineer)

(Date)

GENERAL FACILITY MISSION AND SYSTEM OBJECTIVES

FUNCTIONAL AND ENVIRONMENTAL REQUIREMENTS

1. Physical phenomena/measurements. _____
- a. Range _____
- b. Accuracy (total system) _____
- c. Resolution (total system) _____
- d. Sample/interest rate: _____ Continuous
_____ Intermittent _____ Frequency
- e. Display (real-time): _____ Yes _____ No
- f. Store/record: _____ Yes _____ No
- g. Number of measurements _____
- h. Alarm: _____ Yes _____ No
Limits: _____ Low _____ High
- i. Criticality: _____ High _____ Average _____ Low

2. Sensor/detector/transducer.

Type _____

Sensitivity _____ Nonlinearity _____ Hysteresis _____

Accuracy _____ Resolution _____ Range _____

Maximum Residual Unbalance (zero offset) _____

Temperature Compensation: _____ Yes _____ No

Excitation Power: _____ V _____ AC _____ DC
_____ A _____ Reg. _____ Unreg. _____ Hz

Number of Instruments _____

Environmental

Operating temp _____ Humidity _____

Shock/Vibration _____ Other hazards _____

Protective enclosure: _____ Yes _____ No _____

Mechanical

Physical dimensions _____

Mounting _____ Spatial _____

3. Signal Conditioner/Converter

a. Amplifier

No. of channels _____

Single-ended _____ Differential _____

Gain-Fixed _____ Variable _____ Range _____

Automatic/Manual _____

Accuracy _____ Bandwidth _____

Environmental

Operating temp _____ Humidity _____

Shock/Vibration _____ Other hazards _____

Protective enclosure: _____ Yes _____ No _____

Mechanical

Physical dimensions _____

Mounting _____ Spatial _____

b. Filter

Type: Low-pass _____ High-pass _____ Band-pass _____

Cut-off Frequency _____ Fixed _____ Variable _____

No. of channels _____

Environmental

Operating temp _____ Humidity _____

Shock/Vibration _____ Other hazards _____

Protective enclosure: _____ Yes _____ No

Mechanical

Physical dimensions _____

Mounting _____ Spatial _____

c. Balance _____ Offset _____ Compensation _____

d. Multiplexer

1. Analog: Low level _____ High level _____

No. of inputs per output _____

Input: Single-ended _____ Differential _____

Input voltage range _____ Sample rate _____

2. Digital: Parallel _____ Serial _____

Bits/word _____ No. of channels _____

Address code type _____ (BCD, binary, etc.)

Logic levels: High _____ V Low _____ V

Logic convention: Positive _____ Negative _____

Sample rate _____

Environmental

Operating temp _____ Humidity _____

Shock/Vibration _____ Other hazards _____

Protective enclosure: _____ Yes _____ No

Mechanical

Physical dimensions _____

Mounting _____ Spatial _____

e. Signal Converter

Type: Analog-to-Digital (A/D) _____

Input range _____ V Conversion speed _____ usec

Bits of resolution _____

Digital-to-Analog (D/A) _____

Bits of resolution _____ Conv speed _____ usec

Output Range _____

Environmental

Operating temp _____ Humidity _____

Shock/Vibration _____ Other hazards _____

Mechanical

Physical dimensions _____

Mounting _____ Spatial _____

f. Sensor Power Source: _____ Yes _____ No

AC _____ DC _____ Hz _____ Reg _____ Unreg _____

Voltage _____ Amperage _____ Backup: _____ Yes _____ No

Battery _____ UPS _____ Solar _____

Environmental

Operating temp _____ Humidity _____

Shock/Vibration _____ Other hazards _____

Mechanical

Physical dimensions _____

Mounting _____ Spatial _____

g. Transmission Link

Wire/cable _____ Telemetry _____ Telephone Modem _____

Fiber-optic _____ Other _____

Environmental

Operating temp _____ Humidity _____

Shock/Vibration _____ Other hazards _____

Mechanical

Physical dimensions _____

Mounting _____ Spatial _____

4. Data Processor/Storage/Monitor

a. Computer

Purpose: Data acquisition _____ Process control _____

Data reduction _____ Computation _____

Other _____

1. Peripherals: Monitor _____ Plotter _____

Printer _____ Mag. tape _____ Modem _____

Terminal _____ Disk drive _____ Floppy disk _____

Hard disk _____

2. No. of input data channels _____

Analog _____ Digital _____

3. Main Memory: Type _____ Capacity _____

4. Communications: I/O port(s); 4-20mA _____

IEEE-488 _____ RS-232-C _____ RS-422 _____ RS-449 _____

16-bit parallel _____

5. Power: Primary _____ Backup _____

_____ V AC _____ DC _____ Amps _____ Freq _____

Backup: Battery _____ UPS _____ Solar _____

Available: _____ Yes _____ No _____

6. Grounding scheme _____

7. Network configuration _____

Environmental

Operating temp _____ Humidity _____

Shock/Vibration _____ Other hazards _____

Cooling reqmts _____ Dehumidification _____

Mechanical

Physical dimensions _____

Mounting _____ Spatial _____

Portable _____ Fixed _____

b. Data Logger

Data input: Analog ___ Digital ___ Sample rate _____

Hard copy _____ Internal storage _____ Memory cap. _____

Resolution _____

Remote communications: Modem _____ RF _____ I/O _____

Alarm: Audible _____ Visual _____

Power: Primary _____ Backup _____

_____ V _____ AC _____ DC _____ Amps _____ Hz

Backup: Battery _____ UPS _____ Solar _____

Available: _____ Yes _____ No

Grounding scheme _____

Environmental

Operating temp _____ Humidity _____

Shock/Vibration _____ Other hazards _____

Mechanical

Physical dimensions _____

Mounting _____ Spatial _____

Portable _____ Fixed _____

c. Storage Devices: Disk drives _____ Mag tape units _____

1. Disk drives: Avg access time _____

Unit capacity _____ Controller _____

Floppy _____ Hard _____ Fixed _____ Removable _____

Power: Primary _____ Backup _____

_____ V _____ AC _____ DC _____ Amps _____ Hz

Backup: Battery _____ UPS _____ Solar _____

Available _____ Yes _____ No _____

Grounding scheme _____

Environmental

Operating temp _____ Humidity _____

Shock/Vibration _____ Other Hazards _____

Mechanical

Physical dimensions _____

Mounting _____ Spatial _____

Portable _____ Fixed _____

2. Magnetic tape unit:

Bits per inch (BPI) _____ Tape speed _____ ips

7-track _____ 9-track _____ Reel Size _____

Tape width _____

Power: Primary _____ Backup _____

_____ V _____ AC _____ DC _____ Amps _____ Hz

Backup: Battery _____ UPS _____ Solar _____
Available _____ Yes _____ No _____

Grounding scheme _____

Environmental

Operating temp _____ Humidity _____

Shock/Vibration _____ Other hazards _____

Mechanical

Physical dimensions _____

Mounting _____ Spatial _____

Portable _____ Fixed _____

5. Displays/Alarms

a. Cathode Ray Tube (CRT)

1. Resolution: _____ High _____ Low _____

Video: _____ Composite _____ RGB _____

Screen size _____ Color _____ Monochrome _____

Power: Primary _____ Backup _____

_____ V _____ AC _____ DC _____ Amps _____ Hz _____

Backup: Battery _____ UPS _____ Solar _____

Environmental

Operating temp _____ Humidity _____

Shock/Vibration _____ Other hazards _____

Mechanical

Physical dimensions _____

Mounting _____ Spatial _____

Portable _____ Fixed _____

b. Printer

Type: Character _____ Line _____
Letter quality _____ Dot matrix _____
Communications port: Serial _____ Parallel _____
Data buffer: _____ Yes _____ No _____
Paper: _____ Tractor feed _____ Friction feed _____
Fan fold _____ Roll _____ Size _____
Type font(s) _____

Power: Primary _____ Backup _____
_____ V _____ AC _____ DC _____ Amps _____ Hz

Environmental

Operating temp _____ Humidity _____
Shock/Vibration _____ Other hazards _____

Mechanical

Physical dimensions _____
Mounting _____ Spatial _____
Portable _____ Fixed _____

c. Plotter(s)

Type: Roll _____ Flat bed _____
Plot size _____ No. of pens _____
Communications port: Serial _____ Parallel _____
Data buffer: _____ Yes _____ No _____
Paper size _____ Fonts _____
Power: Primary _____ Backup _____
_____ V _____ AC _____ DC _____ Amps _____ Hz

Environmental

Operating temp _____ Humidity _____

Shock/Vibration _____ Other hazards _____

Mechanical

Physical dimensions _____

Mounting _____ Spatial _____

Portable _____ Fixed _____

d. Strip chart recorder(s)

Type: Pen & ink _____ Heated stylus _____ Point plot _____

Signal input: Sensitivity _____ Freq. response _____

No. of channels _____

Power: Primary _____ Backup _____

_____ V _____ AC _____ DC _____ Amps _____ Hz

Environmental

Operating temp _____ Humidity _____

Shock/Vibration _____ Other hazards _____

Mechanical

Physical dimensions _____

Mounting _____ Spatial _____

Portable _____ Fixed _____

e. Indicators

Type: 1. Status: LED _____ Incandescent _____

Other _____

2. Information: Digital _____ Analog _____
LED _____ LCD _____ Dial/Meter _____
Gas discharge _____ Pointer/Scale _____
Other _____

Power: Primary _____ Backup _____
_____ V _____ AC _____ DC _____ Amps _____ Hz

Environmental

Operating temp _____ Humidity _____

Shock/Vibration _____ Other hazards _____

f. Alarms

Type: Audible _____ Visual _____ Remote _____
Local _____

Power: Primary _____ Backup _____
_____ V _____ AC _____ DC _____ Amps _____ Hz

Environmental

Operating temp _____ Humidity _____

Shock/Vibration _____ Other hazards _____

APPENDIX B: WHEATSTONE BRIDGE DESCRIPTIONS

1. Strain gage elements configured as active Wheatstone bridges are widely used in transducers to measure indirectly such quantities as force, weight, pressure and acceleration. Special considerations and techniques are used to ensure optimum sensor performance in resistive-bridge transducer applications. Sensor "sensitivity" or "span" may be maximized in several ways as follows:

- a. Increase the number of active elements in the bridge.
- b. Increase the "gage factor" (ratio of resistance change and change in element length) of active elements in the bridge.¹

$$\text{Gage Factor} = \frac{\text{deltaR}/R}{\text{deltaL}/L}$$

where deltaR = change in resistance
R = unstrained element resistance
deltaL = change in element length
L = unstrained element length

- c. Increase the "excitation" voltage on the bridge.

CAUTION

Maximum excitation voltage is specified by the transducer manufacturer. Exceeding this level results in sensor damage.

2. Compensation circuitry may be employed (see Figure B1.) to adjust for:

- a. Change in zero-output level (zero).
- b. Full-scale level (sensitivity or span).

1. Seippel, R. H., "Transducers, Sensors, and Detectors," Reston Publishing Company, Inc., Reston, VA, 1983, p.79

- c. Temperature effects on zero.
- d. Temperature effects on full scale.
- e. Input/output impedance matching

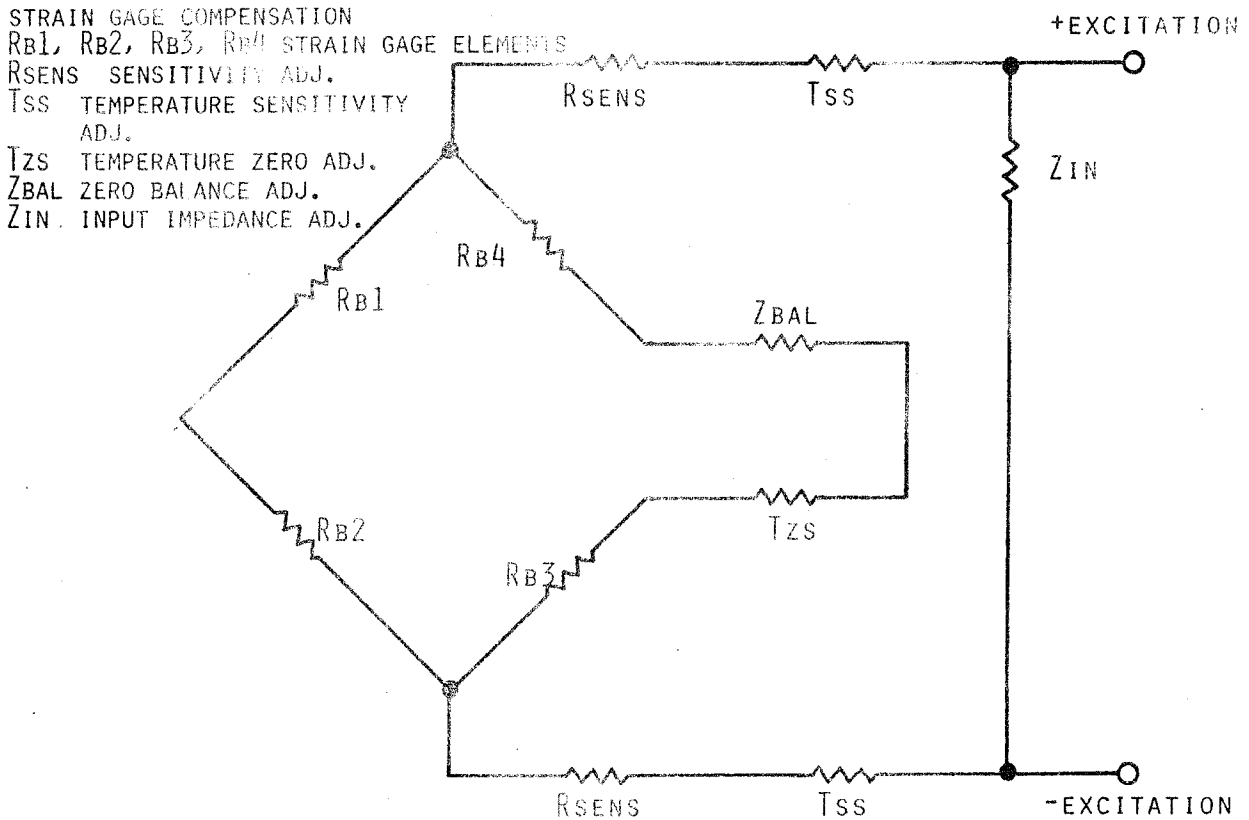

FIGURE B1. STRAIN GAGE COMPENSATION

3. Six-wire connections to the bridge may be used for remote "shunt calibration" and "bridge voltage sensing". See Figures B2 and B3. Shunting an active bridge element with a precise resistance, R_{cal} , is a commonly used electrical calibration method in resistance-bridge transducer applications. The bridge excitation voltage should be stringently regulated and even slight variations must be monitored and accounted for in the translation of electrical signals to engineering units of measurements in the data processing subsystem.

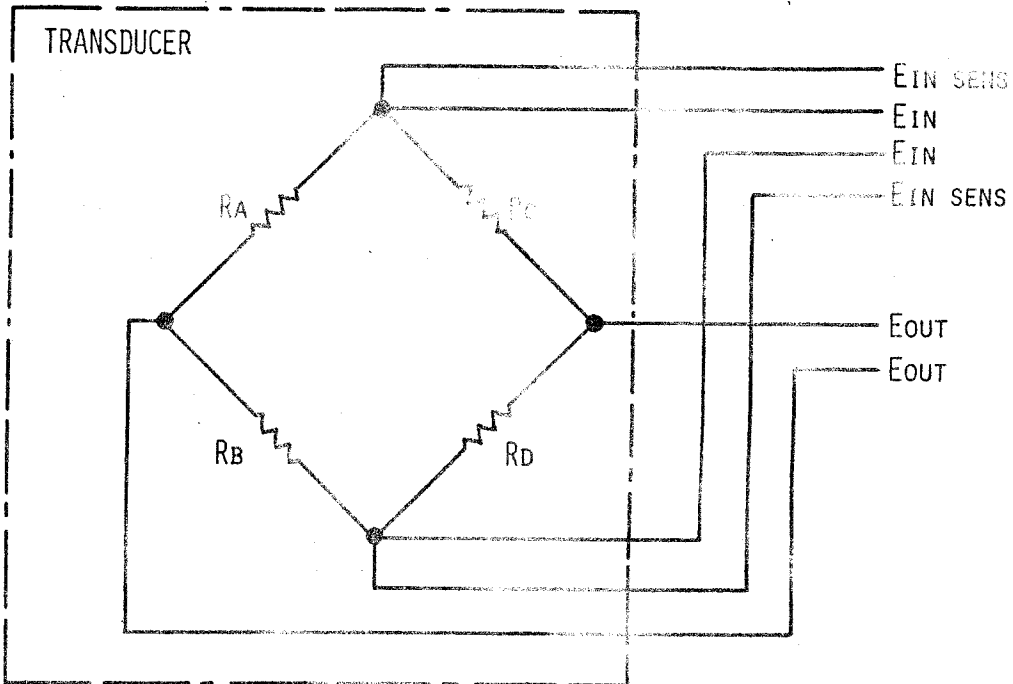

FIGURE B2. STRAIN GAGE TRANSDUCER WITH BRIDGE VOLTAGE SENSING CAPABILITY

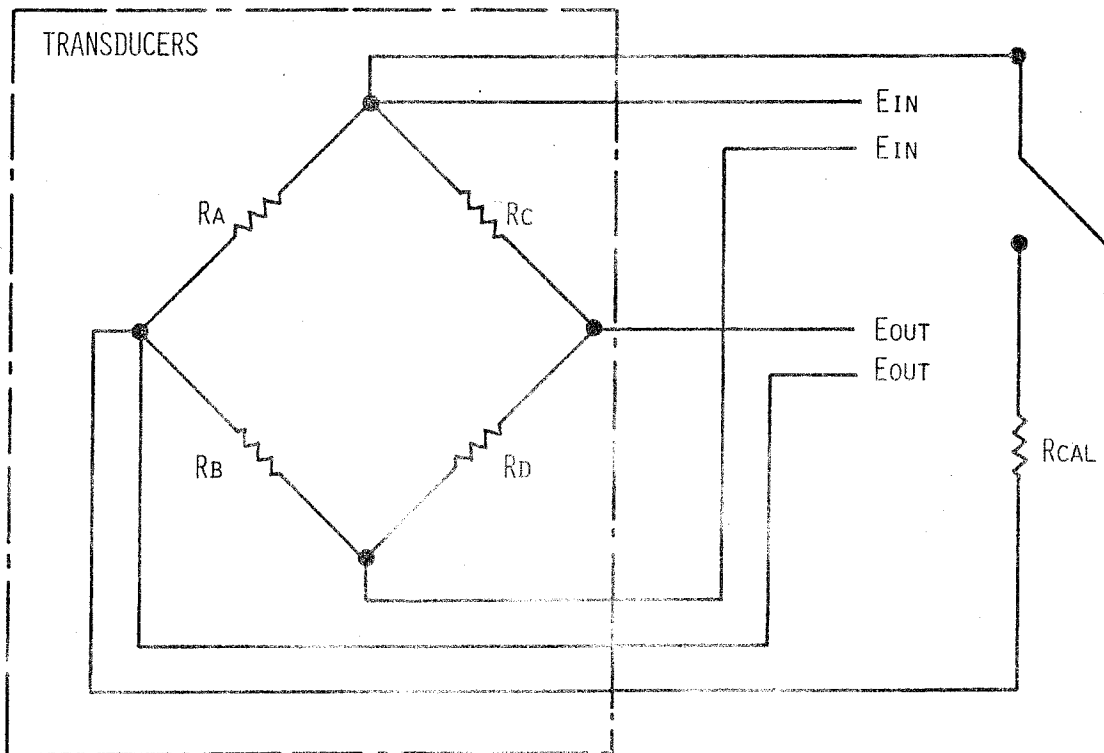

FIGURE B3. STRAIN GAGE TRANSDUCER WITH REMOTE "SHUNT CALIBRATION" CAPABILITY

4. The change in resistance in a strain gage element is usually very small. To measure this change, the strain gage is normally connected as one active element of a Wheatstone bridge; this configuration is frequently called a 1/4 active bridge. The other three elements are dummy "resistors" and may be located at the active gage or in conditioning instrumentation. When the gage is not in a strain condition, the bridge is balanced. Any contraction or elongation of the active gage causes the bridge to "unbalance" and, if the bridge is excited by a voltage E , an electrical output signal, E_{sig} , results. The relative amplitude of this signal is given by the expression: $E_{sig} = E \Delta R/4R$; where R = strain gage resistance, and E = excitation voltage.

5. It is common practice to use two or even four gages in the Wheatstone bridge configuration as shown in Figure B4. The bridge arms that contain strain gages are called active arms. When two gages are used (1/2 active bridge), the resistance can be used to enhance or cancel signals depending on the application. If the change in resistance, ΔR , is in the same direction for two gages, these gages can be placed either in opposite arms to enhance the signal or in adjacent arms to cancel the signal. If the changes in resistance, ΔR , are in the opposite direction, the gage locations are reversed to enhance or cancel the signal. See Figure B4 for the various gage configurations. The bridge signal is given by the expression: $E_{sig} = E \Delta R/2R$.

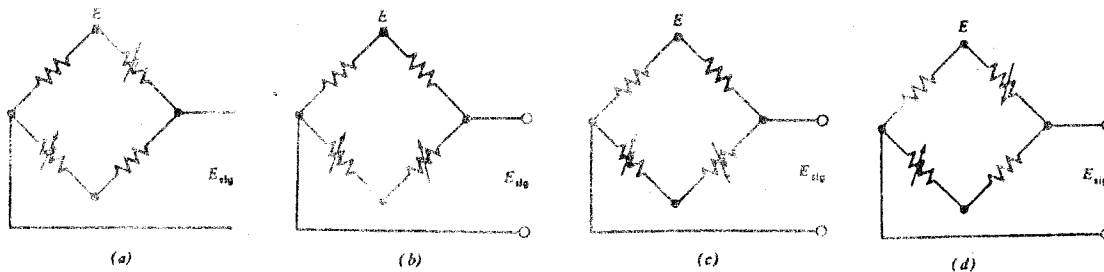

FIGURE B4. VARIOUS TWO-ACTIVE ARM BRIDGE CONFIGURATIONS:
 (A) SIGNAL ENHANCEMENT; (B) SIGNAL CANCELLATION;
 (C) SIGNAL ENHANCEMENT; (D) SIGNAL CANCELLATION

When all four bridge elements are active (full active bridge) and contribute equally to the bridge output, the output signal is given by: $E_{sig} = E \Delta R/R$.

6. Table B1 summarizes the expressions for output signals per unit of bridge excitation, voltage and/or current, plus second-order linearity error terms for various bridge configurations. The term R in the expressions represents the absolute value of the change in resistance of the bridge elements.

Table B1

Output Signal per Unit of Bridge Excitation Plus Second-Order Error Terms for Various Bridge Configurations

| | One Active Arm | Two Active Adjacent | Two Active Opposite | Four Active Arms |
|------------------|--|---|---|----------------------|
| Constant voltage | $\frac{\Delta R}{4R} - \frac{\Delta R^2}{8R}$ | $\frac{\Delta R}{2R} + \frac{\Delta R^2}{8R}$ | $\frac{\Delta R}{2R} - \frac{\Delta R^2}{4R^2}$ | $\frac{\Delta R}{R}$ |
| Constant current | $\frac{\Delta R}{4R} - \frac{\Delta R^2}{16R}$ | $\frac{\Delta R}{2R}$ | $\frac{\Delta R}{2R}$ | $\frac{\Delta R}{R}$ |

7. Remote sensing and elimination of thermally produced errors in lead resistance may be accomplished by the addition of extra sense lines to the active resistance element of the bridge. These sense lines carry very little current compared with the excitation lines. When one active arm is used, bridge current must be carried to this one element. Here, too, signal sensing should not involve leads that carry bridge current. To solve this problem a separate signal line needs to be returned to the amplifier or readout device.

8. As previously stated, bridge completion can take place in the instrumentation or remotely near the active elements. If the distance from the completion point to the

active element is short, then special signal-sensing lines are unnecessary. The one active arm-sensing problem is shown in Figure B5. Here line 1-2 is used to sense one side of the signal, thus eliminating the IR drop in line 1-3. Note that there is no provision to reduce the effect of the IR drop in lead 4-5. A separate line 4-6 may be used to calibrate the one active arm, which removes the error caused by the IR drop in lead 4-5.

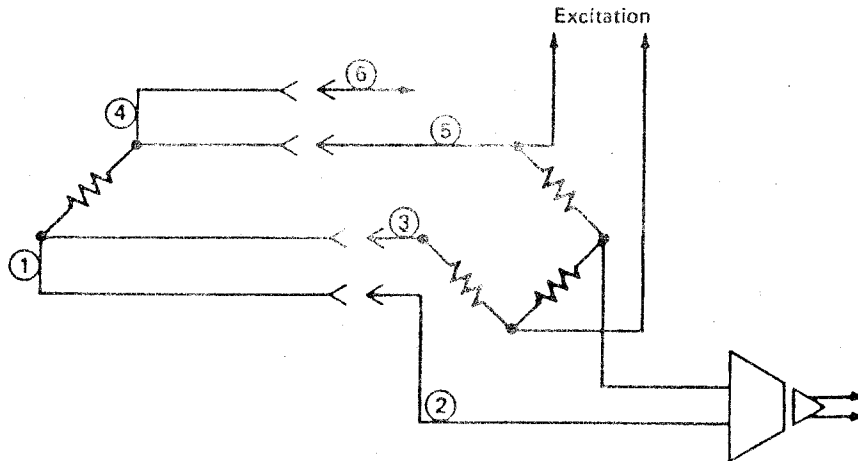

Figure B5. A SEPARATE SIGNAL SENSE LINE

9. The many possible configurations include one, two, or four active bridge elements, remote or local bridge completion, remote or local excitation sensing, remote or local signal sensing, and remote or local calibration connections. The user must be aware of the errors caused by IR drops in the excitation leads, including temperature effects. With this knowledge the user can select a wiring scheme that is best suited to the applications. Present-day instrumentation practices allow users to connect up to ten wires to their gage.

