

MULTI-MEGAMPERE CURRENT INTERRUPTION FROM  
EXPLOSIVE DEFORMATION OF CONDUCTORS\*

J. H. Goforth, A. H. Williams, S. P. Marsh  
Los Alamos National Laboratory  
Los Alamos, NM 87545

Abstract

Two approaches for using explosives to interrupt current flowing in solid conductors are described. One concept uses explosives to extrude the switch conductor into thin regions that fuse due to current in the switch. A preliminary scaling law is presented. The second approach employs dielectric jets to sever current carrying conductors. A feasibility experiment and an improved design are described.

Introduction

Explosive-driven magnetic-flux compression generators (explosive generators) are pulsed power devices capable of delivering tens of megamperes of current to suitable loads. The driving impedance of a generator depends on the derivative of its decreasing inductance. As a result, the driving impedance is limited ultimately by the velocity at which conductors can be driven using explosives. Similarly, the useful electrical pulse length can be no less than the time required to decrease a generator's inductance by a large amount compared to the inductance of the load. For loads requiring a higher driving impedance or shorter pulse length than a specific generator can deliver, the electrical pulse obtained directly from the generator must be conditioned. We are concerned with using explosive generators as power supplies to deliver tens of megamperes in short pulses ( $<1 \mu\text{s}$ ) to low inductance loads. There are, in principle, a variety of ways in which short pulses can be extracted from explosive generators. In practice, our current requirements demand that we make the most efficient possible use of our generator output. Multiple branch circuits with combinations of explosive generators, opening switches and closing switches offer some realistic alternatives. The best option among these is yet to be determined, depending primarily on which opening switch candidates can actually be made to function at the required levels. Figure 1 shows three exemplary circuit possibilities.  $G_1$ ,  $G_2$  and  $G_3$  represent existing explosive generators or generator combinations that have the capacity for delivering 50 MA to a 10 nH load.<sup>1,2</sup> Using known characteristics of these generators and asserting the need to deliver 20 MA to a 10 nH load in 0.5  $\mu\text{s}$  or less we can state some approximate requirements imposed on the switches  $S_1 - S_5$ . Table I summarizes the requirements. Because of the needs of the pulsed power community, there are a large number of opening switch concepts under investigation. Each of these has advantages and disadvantages, although the list shortens dramatically when the requirement to carry many megamperes for several microseconds is imposed. For use in explosive generator circuits, opening switches that make use of high explosives (HE) pose no additional operational difficulty but do offer some advantages. HE driven opening switches operate on command, can be made to conduct for extremely long times, and have energy available for the opening process that can be large compared to the electrical energy of the circuit. There is no rep-rate capability, of course, and as with explosive generators, time scales are limited by velocities achievable by using HE techniques. Time scales imposed in Table I are within the realm of

\*Work supported by the US Department of Energy.

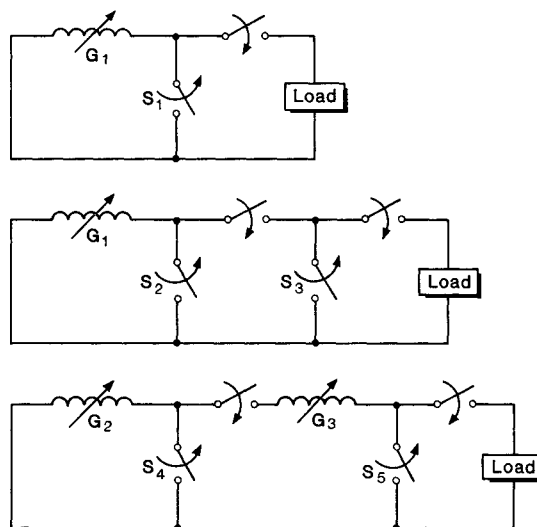

Fig. 1. Exemplary power conditioning circuits.

explosives capabilities, however, and explosive opening switches capable of meeting the needs of each of the switches  $S_1 - S_5$  can be proposed. Another paper in this conference<sup>3</sup> reports on our progress with plasma compression opening switches, (a candidate for  $S_3$  or  $S_5$ ) and we will concentrate in this paper on two devices that make use of explosive techniques to sever metallic conductors massive enough to conduct the entire pulse while remaining in the solid state. A third device of this type is described by Reinovsky et al.<sup>4</sup> in this conference. These concepts are most likely to succeed in filling the needs for switches  $S_2$  and  $S_4$ , although the second switch we will describe has some chance of satisfying the needs of  $S_1$ ,  $S_3$  or  $S_5$ .

Explosively Formed Fuses

The opening switch concept we now choose to denote by "Explosively Formed Fuses" began as an attempt to bring simultaneous initiation systems and substantial volumes of HE to bear on the technique developed by Vitkovitsky et al.<sup>5</sup> Subsequent calculational and experimental efforts have led us to believe that the opening speed provided by the more powerful HE systems alters the opening mechanism of the switch. Figure 2 illustrates the concept. A relatively thick conductor is explosively driven into a void in an insulating anvil. Rather than shearing at the edges of the anvil, two dimensional hydrodynamic code (2-D code) calculations reveal that the material is extruded into thin regions near each anvil edge that apparently fuse under the action of the current.

In small scale tests we used forming anvils with five grooves in series of the type shown in Fig. 2. Plane wave detonation systems were used to drive the conductor into the five grooves simultaneously. The conductor in the switch was 6.4 cm wide, and spanned 7.3 cm in crossing the five grooves. We varied the conductor and the anvil materials during the tests, although our attempts to compare anvil materials that have high and low material strengths have proved

# Report Documentation Page

Form Approved  
OMB No. 0704-0188

Public reporting burden for the collection of information is estimated to average 1 hour per response, including the time for reviewing instructions, searching existing data sources, gathering and maintaining the data needed, and completing and reviewing the collection of information. Send comments regarding this burden estimate or any other aspect of this collection of information, including suggestions for reducing this burden, to Washington Headquarters Services, Directorate for Information Operations and Reports, 1215 Jefferson Davis Highway, Suite 1204, Arlington VA 22202-4302. Respondents should be aware that notwithstanding any other provision of law, no person shall be subject to a penalty for failing to comply with a collection of information if it does not display a currently valid OMB control number.

1. REPORT DATE <b>JUN 1985</b>		2. REPORT TYPE <b>N/A</b>		3. DATES COVERED <b>-</b>	
4. TITLE AND SUBTITLE <b>Multi-Megampere Current Interruption From Explosive Deformation Of Conductors</b>				5a. CONTRACT NUMBER	
				5b. GRANT NUMBER	
				5c. PROGRAM ELEMENT NUMBER	
6. AUTHOR(S)				5d. PROJECT NUMBER	
				5e. TASK NUMBER	
				5f. WORK UNIT NUMBER	
7. PERFORMING ORGANIZATION NAME(S) AND ADDRESS(ES) <b>Los Alamos National Laboratory Los Alamos, NM 87545</b>				8. PERFORMING ORGANIZATION REPORT NUMBER	
9. SPONSORING/MONITORING AGENCY NAME(S) AND ADDRESS(ES)				10. SPONSOR/MONITOR'S ACRONYM(S)	
				11. SPONSOR/MONITOR'S REPORT NUMBER(S)	
12. DISTRIBUTION/AVAILABILITY STATEMENT <b>Approved for public release, distribution unlimited</b>					
13. SUPPLEMENTARY NOTES <b>See also ADM002371. 2013 IEEE Pulsed Power Conference, Digest of Technical Papers 1976-2013, and Abstracts of the 2013 IEEE International Conference on Plasma Science. Held in San Francisco, CA on 16-21 June 2013. U.S. Government or Federal Purpose Rights License. See also ADM002371. 2013 IEEE Pulsed Power Conference, Digest of Technical Papers 1976-2013, and Abstracts of the 2013 IEEE International Conference on Plasma Science. Held in San Francisco, CA on 16-21 June 2013. U.S. Government or Federal Purpose Rights License.</b>					
14. ABSTRACT <b>Two approaches for using explosives to interrupt current flowing in solid conductors are described. One concept uses explosives to extrude the switch conductor into thin regions that fuse due to current in the switch. A preliminary scaling law is presented. The second approach employs dielectric jets to sever current carrying conductors. A feasibility experiment and an improved design are described.</b>					
15. SUBJECT TERMS					
16. SECURITY CLASSIFICATION OF:			17. LIMITATION OF ABSTRACT	18. NUMBER OF PAGES	19a. NAME OF RESPONSIBLE PERSON
a. REPORT <b>unclassified</b>	b. ABSTRACT <b>unclassified</b>	c. THIS PAGE <b>unclassified</b>			

Table I. Constraints on Opening Switches in Fig. 1.

Opening Switch	Conduction Time	Peak Current	Conduction Resistance	Inductance	Open R	Opening Time
S <sub>1</sub>	~500 $\mu$ s	40 MA	<1 m $\Omega$	10 nH	>0.1 $\Omega$	<0.5 $\mu$ s
S <sub>2</sub>	~500 $\mu$ s	25 MA	<1 m $\Omega$	10 nH	>0.1 $\Omega$	2-5 $\mu$ s
S <sub>3</sub>	~10 $\mu$ s	40 MA	<1 m $\Omega$	<10 nH	>0.1 $\Omega$	<0.5 $\mu$ s
S <sub>4</sub>	~400 $\mu$ s	10 MA	<10 m $\Omega$	20 nH	<0.1 $\Omega$	2-5 $\mu$ s
S <sub>5</sub>	~100 $\mu$ s	40 MA	<1 m $\Omega$	10 nH	>0.1 $\Omega$	<0.5 $\mu$ s

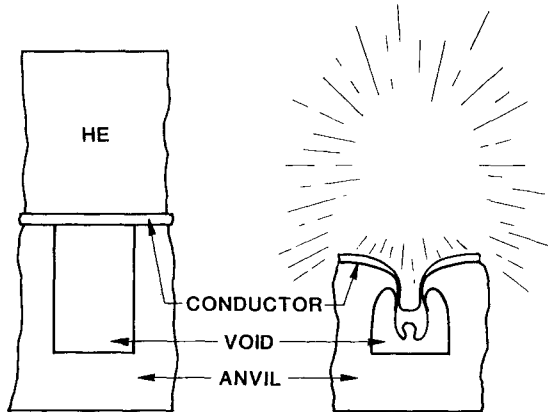

Fig. 2. Explosively Formed Fuse Concept. Conduction phase is shown on the left and a 2-D code prediction of the dynamic opening phase on the right. Anvil material in this calculation is Teflon.

inconclusive. We also performed some tests in which 6.4 cm thick Teflon was inserted between the HE and the conductor. We will refer to these as Teflon follower tests. Equal thicknesses of aluminum, brass and Inconel 625 were used to study different conductors. We chose aluminum as a high conductivity material that extrudes reasonably well under the action of explosives. In contrast, brass is a good conductor that fragments in similar circumstances. Inconel 625 was chosen as a low conductivity metal, to see if the much higher initial resistance would lead to a similarly higher final open switch resistance. No correlation was found between initial and final resistivity, but the hydrodynamics play such an overwhelming role in the fusing process, that the details of the extrusion will have to be known very well before definitive statements can be made. In addition, the tendency of brass to rupture under explosive stresses did not effect its performance as an opening switch. The material property that correlates with the data is the mass being driven by the HE. The lower the mass, the faster the conductor is extruded by the explosive gases. This trend continues when Teflon is inserted between the HE and conductor, as is illustrated in Fig. 3 where the opening switch voltages from three tests are plotted. In the figure, we see that the voltage rise, corresponding to the beginning of the opening switch resistance rise, begins increasingly later as the mass being driven by the explosives increases. In all these tests the current in the circuit was driven to zero, indicating no restrike of the current path. Substantial resistances were obtained in these opening switches as is shown in Fig. 4, where resistances are plotted for a bare aluminum (illustrated in Fig. 2) and a Teflon follower test. While the Teflon follower test takes longer for the resistance to rise, it still achieves a very high resistance, and shows evidence of remaining at a higher value. The circuit for our small scale tests

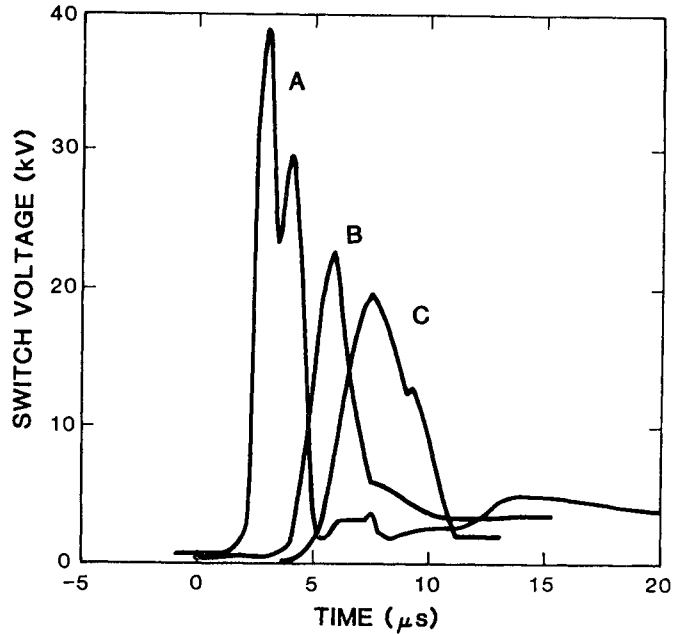

Fig. 3. Voltage waveforms from small scale tests. Curves A and B are from tests with aluminum and brass conductors respectively in experiments as illustrated in Fig. 2. Curve C is from a Teflon follower test with aluminum conductor.

consisted of a 1500  $\mu$ F capacitor bank that was discharged into the switch through low inductance cables. The total circuit inductance was ~160 nH. No alternate current path was provided when the opening action occurred, and thus the drop in current is due to energy dissipated in the switch. At a current of 400 kA, ~13 kJ are dissipated in the opening switch. For most of our applications the fast rise exhibited by curve A in Figs. 3 and 4 has been considered important and it is on this combination that we have concentrated subsequent efforts. Table II summarizes the details.

If the opening mechanism for our small scale experiment is as we have proposed, the energy dissipation in the switch should be proportional to the width of the conductor and the number of grooves in the anvil. To verify this relationship, we conducted experiments in which the length and width of the small scale device were both doubled. That is, we made the conductor 12.7 cm wide and long enough to span 10 grooves. We propose that this switch should be able to dissipate ~50 kJ of circuit energy in the opening process. Tests of this system were in a circuit consisting of a 1500  $\mu$ F capacitor bank and the switch, with a total circuit inductance of ~450 nH. With 750 kA flowing in this circuit, the opening switch explosive charges were actuated. The resulting opening switch action reduced the current to 600 kA before a restrike occurred, indicating an energy dis-

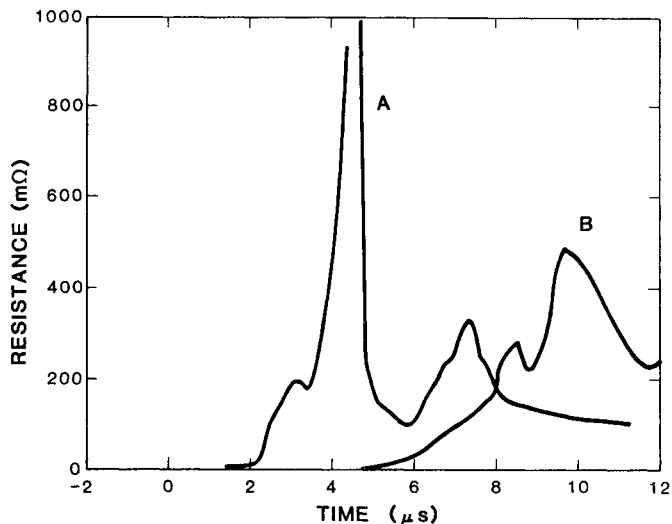

Fig. 4. Resistance increases developed in bare aluminum test (A) and Teflon follower test (B).

sipation of ~46 kJ. We consider this result a preliminary verification of the scaling law. Restrike occurred on this shot after ~80 kV was generated across the ten channels representing a resistance rise to over 100 mΩ in ~1 μs.

Finally, we performed tests to verify that the switch will not restrike if an alternate current path is provided, allowing the switch to dissipate an amount of energy ~50 kJ or less. We briefly describe the results of the most interesting of these. The test consisted of using a capacitor bank to provide initial magnetic flux for a small flat plate explosive generator.<sup>6</sup> The generator is then the prime power supply, amplifying the current in the circuit. At an appropriate time, the opening switch was actuated and a detonator-triggered closing switch allowed the remaining current to flow into a parallel ~5 nH load. Figure 5 shows the current waveforms. Eight μs after the beginning of the generator pulse ~1.7 MA were flowing in the opening switch. At this time, the opening and closing switches were actuated. The current in the opening switch was reduced to zero after ~5 μs and the total generator current was then flowing in the load, reaching a peak of over 7 MA. This experiment not only reveals an acceptable opening action, but that no restrikes occurred in the switch for over 10 μs.

Jet Actuated Opening Switches

A well understood explosives technique that can be brought to bear on the opening switch problem is that of shock wave induced jetting. The ability of metallic jets to penetrate heavy armor is well known. Dielectric materials can also be made to produce jets, and it is proposed to use these as opening switches. We have performed 2-D code calculations to gain an understanding of the important hydrodynamic considerations, and have conducted preliminary experiments.

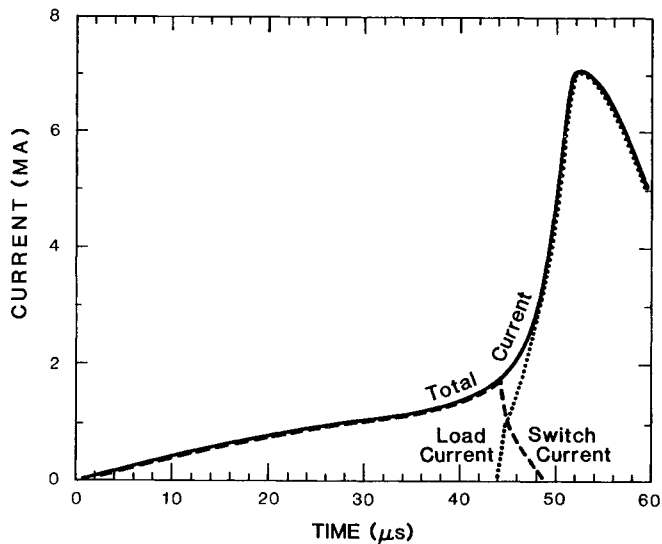

Fig. 5. Switch, Load and Total Currents in Explosively Formed Fuse current transfer test.

Nazet<sup>7</sup> has done exploratory work on this subject also, although we did not become aware of the extent of his work in time to take advantage of it in our first experiments. The most exciting prospect offered by jet actuated opening switches is that of very fast opening times. Figure 6 illustrates the concept. A thick conductor (~0.08 cm) is positioned adjacent to a dielectric material manufactured in a proper geometry to form a series of line jets when shocked by an HE system. On the opposite side of the conductor is an anvil against which the jets and conductors are driven. Current flows through the conductor until it is ruptured along each of the line jets. The blown up section of Fig. 6 shows the result of a 2-D code calculation of an AlO<sub>2</sub> jet penetrating an aluminum conductor and impinging on an AlO<sub>2</sub> anvil. We have conducted a low current experiment that demonstrates that a resistance rise can be achieved in this manner. Although calculations suggest that AlO<sub>2</sub> is the best jet material for this application, it was difficult to obtain AlO<sub>2</sub> hardware for this purpose in a timely manner. Likewise, Nazet's<sup>7</sup> work suggests Teflon and Polyethylene are better materials than AlO<sub>2</sub>, but we were not aware of this when we did our tests. As a result, a system consisting of 9 annular jets and anvils was constructed from Maycor, a machinable ceramic. The radius of the outer jet groove was 9.5 cm and the radius of the inner jet groove was 1.6 cm. An aluminum conductor 0.08 cm thick was inserted between the two Maycor parts and attached to transmission plates in such a way that current flowed radially in the annulus. A 1500 μF capacitor bank was used to supply 1.4 MA to the switch. A plane wave HE system was used to drive the jets simultaneously into the aluminum. The resistance rise caused by the jets cutting the annular conductor is shown in Fig. 7. It consists of an initially fast rise, a pause and then a somewhat slower resistance rise. Eventually restrike occurs. The circuit inductance was ~100 nH and the

Table II. Description of Fastest Small Scale System

<u>Conductor</u>	<u>Driver System</u>	<u>Anvil</u>
0.08 cm thick aluminum 6.4 cm wide	PBX-9501 in direct contact with con- ductor	Teflon with five 0.9 cm wide x 0.9 cm deep grooves sepa- rated by 0.7 cm
<u>Current Capacity</u>	<u>Energy Dissipated</u>	<u>Voltage Standoff</u>
400 kA	13 kJ	48 kV/5 channels

current was reduced from 1.4 MA to ~0.7 MA. A total of ~75 kJ were dissipated during this resistance pulse.

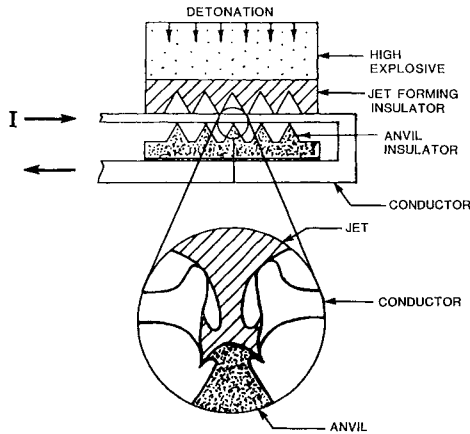

Fig. 6. Jet Actuated Opening Switch concept. The blown up section shows the severing action predicted by a 2-D code calculation.

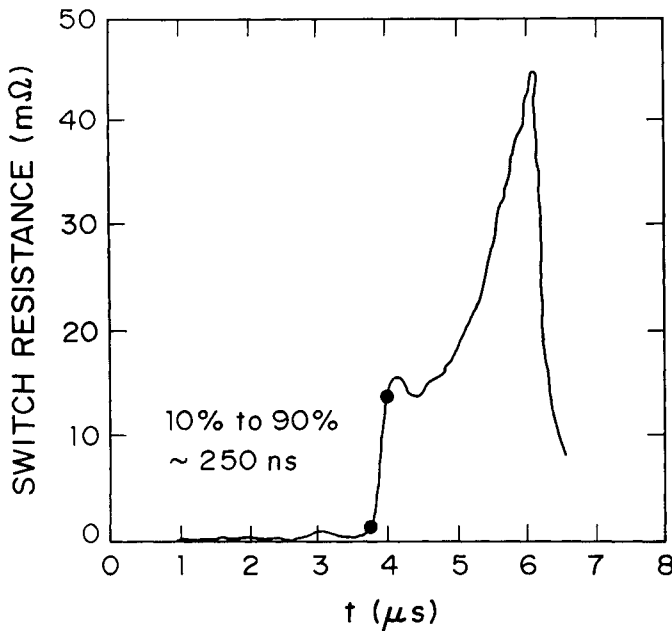

Fig. 7. Resistance rise achieved in a preliminary Jet Actuated Opening Switch test.

Although the speed of the initial resistance rise is exciting, to be useful in applications where currents approach 40 MA, the energy dissipated per unit area in the switch will probably need to be increased. Insight gained from 2-D code calculations allows us to propose a different configuration for jet actuated opening switches with enhanced energy dissipation. In the new configuration, jets are aimed at each other from opposite sides of the aluminum conductor. The speed with which the conductor is severed does not substantially increase, but the rate at which dielectric material flows into the gap made by the jets is considerably enhanced. Our calculations deal only with hydrodynamics, but it is reasonable to expect the enhanced flow of dielectric material to lead to enhanced energy dissipation. We will test this premise as soon as possible.

## Conclusion

We have performed a variety of small scale tests in which metallic conductors are explosively driven into a series of grooves in a dielectric material. Apparently, the conductor is extruded into thin regions near the edges of each groove and current flowing in the circuit (transverse to the grooves) causes the conductor to fuse in the thin regions. Current is thus interrupted as long as the switch has the capacity to dissipate the circuit energy. The switches, as tested, will hold off ~8-10 kV/groove and dissipate 0.41 kJ per centimeter of groove width. Resistances of the order of 20-40  $\text{m}\Omega$ /groove are also achieved in 1-2  $\mu\text{s}$ , where the ratio of number of grooves to groove width is ~0.78. Using these scaling laws, a coaxial switch can be designed that should carry ~10 MA and open in 2-5  $\mu\text{s}$ , satisfy the needs of switch  $S_4$  in Fig. 1. We have demonstrated that explosively formed fuses will work in explosive generator drive current transfer experiments, and that in these experiments, the switch will remain open for at least 10  $\mu\text{s}$ .

Opening switches are proposed with the cutting action of dielectric jets used to sever solid metal conductors. An experiment verifies that a fast rising resistance similar to that required by  $S_1$ ,  $S_3$  or  $S_5$  can be achieved. An improved geometry has been proposed on the basis of 2-D calculations.

## References

- [1] R. S. Caird, D. J. Erickson, C. M. Fowler, R. F. Benjamin, L. R. Veaser, A. H. Williams, J. H. Goforth, B. L. Freeman, "Tests of an Explosive-Driven Coaxial Generator," to be published in this conference.
- [2] J. H. Degnan, W. L. Baker, C. M. Fowler, R. S. Caird, D. J. Erickson and B. L. Freeman, "Test of 10 Megajoule Electrical Output Magneto - Cumulative Generator," Proceedings of the Third International Conference on Megagauss Magnetic Field Generation and Related Topics, Novosibirsk, June 13-17, 1983, V. M. Titov, G. A. Shvetsov, Eds., (Moscow "Nauka," 1984), pp. 352-358.
- [3] J. H. Goforth, D. J. Erickson, A. H. Williams and A. E. Greene, "Multimegampere Operation of Plasma Compression Opening Switches in Planar Geometry," to be published in this conference.
- [4] R. E. Reinovsky, P. S. Levi, J. G. Bueck and J. H. Goforth, "Parallel, Staged Opening Switch Power Conditioning Techniques for Flux Compression Generator Applications," to be published in this conference.
- [5] I. M. Vitkovitsky, D. Conte, R. D. Ford and W. F. Lupton, Naval Research Laboratory Memorandum Report 4168, March 5, 1980.
- [6] R. S. Caird, D. J. Erickson, C. M. Fowler, B. L. Freeman and J. H. Goforth, "A Circuit Model for the Explosive-Driven Plate Generator," proceedings as cited in ref. [3] above, pp. 246-253.
- [7] C. Nazet, "Explosive Switch," CEA-R-4349 (Commissariat A L'Energie Atomique), 1972.