

Report Documentation Page

Form Approved
OMB No. 0704-0188

Public reporting burden for the collection of information is estimated to average 1 hour per response, including the time for reviewing instructions, searching existing data sources, gathering and maintaining the data needed, and completing and reviewing the collection of information. Send comments regarding this burden estimate or any other aspect of this collection of information, including suggestions for reducing this burden, to Washington Headquarters Services, Directorate for Information Operations and Reports, 1215 Jefferson Davis Highway, Suite 1204, Arlington VA 22202-4302. Respondents should be aware that notwithstanding any other provision of law, no person shall be subject to a penalty for failing to comply with a collection of information if it does not display a currently valid OMB control number.

1. REPORT DATE JUN 1985	2. REPORT TYPE N/A	3. DATES COVERED -			
4. TITLE AND SUBTITLE Nanoseconds Jitter - 100 KV Trigger Generator System		5a. CONTRACT NUMBER			
		5b. GRANT NUMBER			
		5c. PROGRAM ELEMENT NUMBER			
6. AUTHOR(S)		5d. PROJECT NUMBER			
		5e. TASK NUMBER			
		5f. WORK UNIT NUMBER			
7. PERFORMING ORGANIZATION NAME(S) AND ADDRESS(ES) Maxwell Laboratories, Inc. 9244 Balboa Avenue San Diego, CA 92123		8. PERFORMING ORGANIZATION REPORT NUMBER			
9. SPONSORING/MONITORING AGENCY NAME(S) AND ADDRESS(ES)		10. SPONSOR/MONITOR'S ACRONYM(S)			
		11. SPONSOR/MONITOR'S REPORT NUMBER(S)			
12. DISTRIBUTION/AVAILABILITY STATEMENT Approved for public release, distribution unlimited					
13. SUPPLEMENTARY NOTES See also ADM002371. 2013 IEEE Pulsed Power Conference, Digest of Technical Papers 1976-2013, and Abstracts of the 2013 IEEE International Conference on Plasma Science. Held in San Francisco, CA on 16-21 June 2013. U.S. Government or Federal Purpose Rights License					
14. ABSTRACT A trigger system capable of producing a 100 kV pulse with a jitter of less than two nanoseconds has been designed and built. The system is self-contained and can be fully isolated by the use of pneumatic control lines, fiber optic trigger command links, and hydraulic power lines. Experiments conducted with the system produced data demonstrating the strong dependence of low jitter on proper UV irradiation of the spark gap switches. The results will be discussed.					
15. SUBJECT TERMS					
16. SECURITY CLASSIFICATION OF:			17. LIMITATION OF ABSTRACT	18. NUMBER OF PAGES	19a. NAME OF RESPONSIBLE PERSON
a. REPORT unclassified	b. ABSTRACT unclassified	c. THIS PAGE unclassified	SAR	2	

NANOSECONDS JITTER - 100 kV TRIGGER GENERATOR SYSTEM*

S. Lloyd, E. Brown, Y.G. Chen, R. Crumley

Maxwell Laboratories, Inc.
9244 Balboa Avenue
San Diego, CA 92123
(619) 279-5100

C. Baum, W. Walton
Air Force Weapons Laboratory
Albuquerque, NM

Abstract

A trigger system capable of producing a 100 kV pulse with a jitter of less than two nanoseconds has been designed and built. The system is self-contained and can be fully isolated by the use of pneumatic control lines, fiber optic trigger command links, and hydraulic power lines.

Experiments conducted with the system produced data demonstrating the strong dependence of low jitter on proper UV irradiation of the spark gap switches. The results will be discussed.

Introduction

Maxwell Laboratories, Inc. (MLI) has built and tested 5 trigger generator systems. The systems are fully isolated electrically by a combination of hydraulic, pneumatic and fiber optic umbilicals.

System Description

The trigger system provides up to 10 trigger outputs. The trigger system is electrically isolated from all other systems with the exception of the unit they are triggering. Figure 1 is a photo of the system and Figure 2 is a block diagram of a trigger cabinet. The power is provided by a hydraulic alternator system. The cabinet is connected to the main hydraulic drive unit via dielectric hoses. All control functions for the trigger systems are remotely controlled by pneumatic lines. The fire command and fire confirmed signal are transmitted via fiber optic links.

Hydraulic System

The hydraulic system consists of two units: the main drive unit, which supplies power to the trigger cabinet, and the on board hydraulic alternator system mounted in the cabinet. Dielectric hoses carry fluid to the trigger system. The on board hydraulic alternator units consist of a hydraulically driven motor coupled to an alternator. A feedback circuit and servo control valve maintain a constant rpm on the motor and hence a constant frequency on the alternator. The alternator output is a nominal 115 VAC at 60 Hz. Power output from the alternator is connected directly to the trigger system.

The raw output is used to power the heaters and fans while the electronics and trigger generators run off of conditioned power provided by a frequency converter.

* Work sponsored by the Air Force Weapons Laboratory under Contract No. F29601-82-C-0092.

Frequency Converters

The frequency converters are used to provide a stable constant frequency and voltage to the trigger generators and electronics. The trigger generators especially require a constant voltage as the throughput delay is a function of voltage. The frequency converters are a Topaz model 1000FZ-115-60-115. They are capable of accepting an input in the range of 100 to 125 volts and 45-65 Hertz and maintaining an output of 115 volts 60 Hertz. The rated power is 1 kVa. The possibly varying amplitude of the A.C. output from the alternator is rectified, filtered and applied to an inverter. The inverter then converts the dc input into a square wave.

Model 40168 Trigger Generator

The model 40168 trigger generator is the second step in the trigger pulse generation. The first step is receiving the fiber optic fire command. The fiber optic receiver produces a 50 volt pulse suitable to trigger the 40168. The 40168 produces a 50 kV output pulse suitable for triggering the last stage (model 40151) trigger generator. The 40168 consists of a 500 volt trigger amplifier which steps up the low level input from the fiber optic link to 500 volts. This signal is used in turn to trigger a thyatron which produces a 12 kV pulse. The thyatron pulse then triggers the spark gap switch which switches out the energy stored in the 6nF of capacitance at 36 kV. Also included is all the necessary circuitry to interconnect the various stages, bias the thyatron and spark gap switch and irradiate the spark gap switch.

Model 40151 Trigger Generator

The model 40151 trigger generator delivers a 100 kV trigger pulse to up to ten outputs. The 40151 consists of a 60 kV high voltage power supply which is used to charge seven 1nF capacitors, a spark gap switch and the necessary circuitry to bias and irradiate the switch. The 40151 is mounted in a SF₆ gas tight compartment in the trigger cabinet.

Controls

The controls are mounted opposite the hydraulic system in the cabinet. They consist of pneumatic switches to sense the commands from the control console, a thermostat to control the fans and heaters, and the fiber optics links. A fiber optic receiver

detects the fire command from the remote control console. Solid state electronics in the receiver produce a 50 volt pulse suitable for triggering the model 40168 trigger generator. When the trigger system fires, a fiberoptic transmitter converts the signal from the output pulse monitor probe to a light pulse. This pulse is then sent back to the control console where it may be monitored for timing purposes.

Probe

The main purpose of the probe is to allow the system operator to determine when the trigger pulse is actually delivered. The probe is an I-dot probe which mounts on one of the trigger system output cables. The output of the probe is connected to the fiberoptic transmitter in the trigger cabinet by coaxial cable. The integrated signal from this probe was used to monitor the system performance during testing.

Testing

The trigger systems were tested for jitter and reproducibility. Figure 3 shows a typical jitter waveform of ten shots overlaid on a single photograph. It can be seen that reproducibility is excellent. Table 1-1 lists the results of the jitter tests.

TABLE 1-1

SUMMARY OF JITTER MEASUREMENTS

UNIT NUMBER	JITTER NS ONE SIGMA
1	1.6
2	1.4
3	1.4
4	1.9
5	1.6

Irradiation Effects Tests

To gain a better understanding of the effects of irradiation on a spark gap switch jitter, some experiments were conducted. With the irradiation pin in the model 40168 trigger generator properly set, the irradiation pin in the model 40151 trigger generator was intentionally shorted out. The jitter became worse with a spread of up to 18 ns. Figure 4 is a photograph of ten shots overlaid showing the poor jitter. Next, we shorted out the pin in the model 40168 trigger generator also. The jitter became much worse, with a total spread in the microsecond range. From these results we can conclude that proper setting of the irradiation pins is very important to guarantee a low jitter system.

Summary

Maxwell Laboratories has built and tested five fully isolated trigger systems. The systems were all shown to have a jitter of less than 2 ns one-sigma. A brief experiment conducted with the systems demonstrated the

strong dependence of low jitter on proper irradiation.

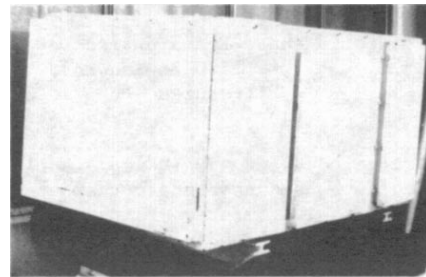

Fig. 1 Photograph of Trigger Cabinet

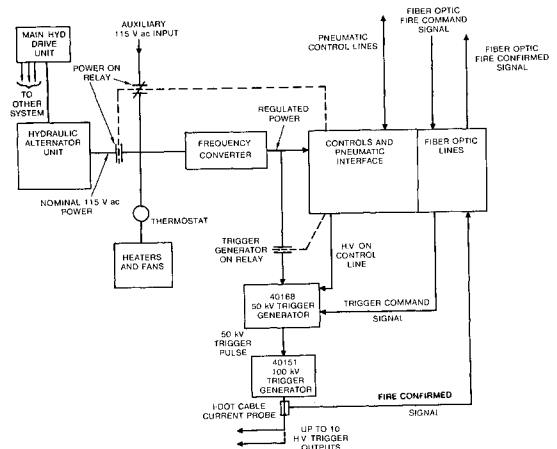

Fig. 2 Block Diagram

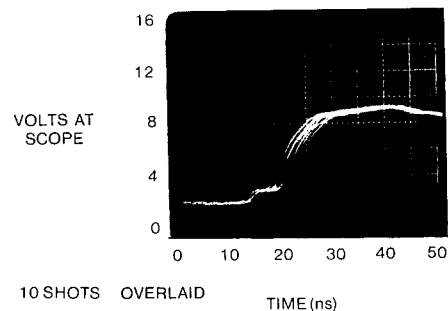

Fig. 3 Typical Jitter Waveform

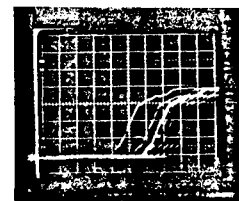

Fig. 4 Poor Jitter Resulting From Improper Irradiation.