

Performance Characteristics of the Atlas 60 KV, 60 KJ Plastic Capacitors

W. Reass, G. Bennet, D. Bowman, E. Lopez, M. Monroe, and W. Parsons
Los Alamos National Lab
P.O. Box 1663, Los Alamos, NM 87544

Abstract - This paper provides the performance data of Atlas plastic capacitors as supplied by Maxwell Technologies and Aerovox Corporation. The fiberglass cases are 13" high by 29" wide and 28" in depth with a 2" by 18" bushing on each end. Two styles of the 33.5uF capacitors have been evaluated for Atlas use, a conventional paper-foil and a self-healing metalized-paper and plastic dielectric design. A test program to capacitor failure, is being used to evaluate capacitor lifetime at full voltage (60 kV) and a nominal 15% reversal. With the Atlas parameters, peak currents of ~340 kA are realized. In anticipation of faults, capacitors are capable, specified, and tested for 700 kA performance. Accurate methods are also utilized to determine capacitor inductance, less than 20 nH. The results of the various capacitor testing programs will be presented in addition to future directives for our R&D efforts.

I. INTRODUCTION

The Atlas plastic capacitor design permits the design of modern Marx bank assemblies with minimum inductance and high peak current. The Atlas capacitors are specified as outlined in Table 1.

Table 1: 60 KJ Plastic Capacitor Specifications

Nominal Capacitance: 33.4 uF
Rated Voltage: 60 kV
Voltage Reversal: 15% with rated lifetime
Nominal Current: 330 kA, 6 uS FWHM
Fault Current: 660 kA, 25% reversal
Lifetime: 2400 shots with 95% survival
Inductance: less than 20nH
Case: 13"H x 29"W x 28"D
Weight: ~600 lbs

This design yields an energy density of 5.7 J/cu-in, a seemingly conservative value by modern standards. The Atlas building block is shown in Figure 1 and consists of a pair of plastic capacitors that are banded together with plastic straps. A railgap switch is mounted between one pair of capacitor terminals and the output line (not shown) is connected to the rear facing electrodes. This capacitor design topology was chosen to permit

reliable air or oil operation, simplified interconnect hardware, and low current density interconnects. All capacitor and module testing to date has been in air with "multi-lam" or "knife-edge" interconnection joints. There has been no noticeable current joint erosion to date (~12,000 shots) or capacitor case dielectric or tracking failures. We have had two failures (arcs) between the external railgap terminals, due to flashguard integrity problems.

II. Testing

For the capacitor evaluations, the Atlas Marx modules are assembled into a G10 support structure as shown in Figure 2. Wheels are provided to slide the Marx module into and out of our electrically and acoustically shielded test vaults (as shown in Figure 3). The test waveforms are digitized and stored for further analysis if required. The primary test intent is determine the capacitor lifetime statistics and develop railgap maintenance procedures. Two charge time intervals have been used for the capacitor testing. A 12 second charge time (for the capacitors evaluated in this report) and more recently, a 28 second charge time. The different charges times have been used to evaluate railgap prefire statistics as related to charging duration. A longer charge time would be beneficial to reduce power supply and utility installation costs. There is no appreciable hang time (~1s) before the capacitors are discharged. An added plus of our capacitor test program has enabled us to evaluate and modify railgap maintenance procedures that minimize prefires. The new maintenance procedure has extended the railgap re-build interval to over 160 shots.

III. INITIAL TEST RESULTS

The first sets of capacitors to be tested were manufactured by Maxwell Technologies. These paper-foil capacitors with castor oil impregnant had a high yield of about 35 uF and a measured inductance of 20 nH. Unfortunately, this first batch of capacitors failed early as shown in Table 2.

Report Documentation Page

Form Approved
OMB No. 0704-0188

Public reporting burden for the collection of information is estimated to average 1 hour per response, including the time for reviewing instructions, searching existing data sources, gathering and maintaining the data needed, and completing and reviewing the collection of information. Send comments regarding this burden estimate or any other aspect of this collection of information, including suggestions for reducing this burden, to Washington Headquarters Services, Directorate for Information Operations and Reports, 1215 Jefferson Davis Highway, Suite 1204, Arlington VA 22202-4302. Respondents should be aware that notwithstanding any other provision of law, no person shall be subject to a penalty for failing to comply with a collection of information if it does not display a currently valid OMB control number.

1. REPORT DATE JUN 1997	2. REPORT TYPE N/A	3. DATES COVERED -	
4. TITLE AND SUBTITLE Performance Characteristics of the Atlas 60 KV, 60 KJ Plastic Capacitors		5a. CONTRACT NUMBER	
		5b. GRANT NUMBER	
		5c. PROGRAM ELEMENT NUMBER	
6. AUTHOR(S)		5d. PROJECT NUMBER	
		5e. TASK NUMBER	
		5f. WORK UNIT NUMBER	
7. PERFORMING ORGANIZATION NAME(S) AND ADDRESS(ES) Los Alamos National Lab P.O. Box 1663, Los Alamos, NM 87544		8. PERFORMING ORGANIZATION REPORT NUMBER	
9. SPONSORING/MONITORING AGENCY NAME(S) AND ADDRESS(ES)		10. SPONSOR/MONITOR'S ACRONYM(S)	
		11. SPONSOR/MONITOR'S REPORT NUMBER(S)	
12. DISTRIBUTION/AVAILABILITY STATEMENT Approved for public release, distribution unlimited			
13. SUPPLEMENTARY NOTES See also ADM002371. 2013 IEEE Pulsed Power Conference, Digest of Technical Papers 1976-2013, and Abstracts of the 2013 IEEE International Conference on Plasma Science. Held in San Francisco, CA on 16-21 June 2013. U.S. Government or Federal Purpose Rights License.			
14. ABSTRACT This paper provides the performance data of Atlas plastic capacitors as supplied by Maxwell Technologies and Aerovox Corporation. The fiberglass cases are 13 high by 29 wide and 28 in depth with a 2 by 18 bushing on each end. Two styles of the 33.5uF capacitors have been evaluated for Atlas use, a conventional paper-foil and a self-herding metallized-paper and plastic dielectric design. A test program to capacitor failure, is being used to evaluate capacitor lifetime at full voltage (60 kV) and a nominal 15% reversal. With the Atlas parameters, peak currents of-340 kA are realized. In anticipation of faults, capacitors are capable, specified, and tested for 700 IA performance. Accurate methods are also utilized to determine capacitor inductance, less than 20 nH. The results of the various capacitor testing programs will be presented in addition to future directives for our R&D efforts.			
15. SUBJECT TERMS			
16. SECURITY CLASSIFICATION OF:			17. LIMITATION OF ABSTRACT
a. REPORT unclassified	b. ABSTRACT unclassified	c. THIS PAGE unclassified	SAR
			18. NUMBER OF PAGES 4
			19a. NAME OF RESPONSIBLE PERSON

Table 2: Maxwell Paper-Foil Capacitor Failures

- #1: 420 Shots at Full Atlas Parameters, 636 Total
- #2: 843 Shots at Full Atlas Parameters, 931 Total
- #3: 1513 Shots at Full Atlas Parameters, 1810 Total
- #4: 2097 Shots at Full Atlas Parameters, 2429 Total

These capacitor failures indicate a capacitor lifetime not suitable for Atlas use. The manufacturer and Los Alamos performed autopsies to determine the principal cause of these early failures. An

Figure 1: Atlas 120 kV Building Block

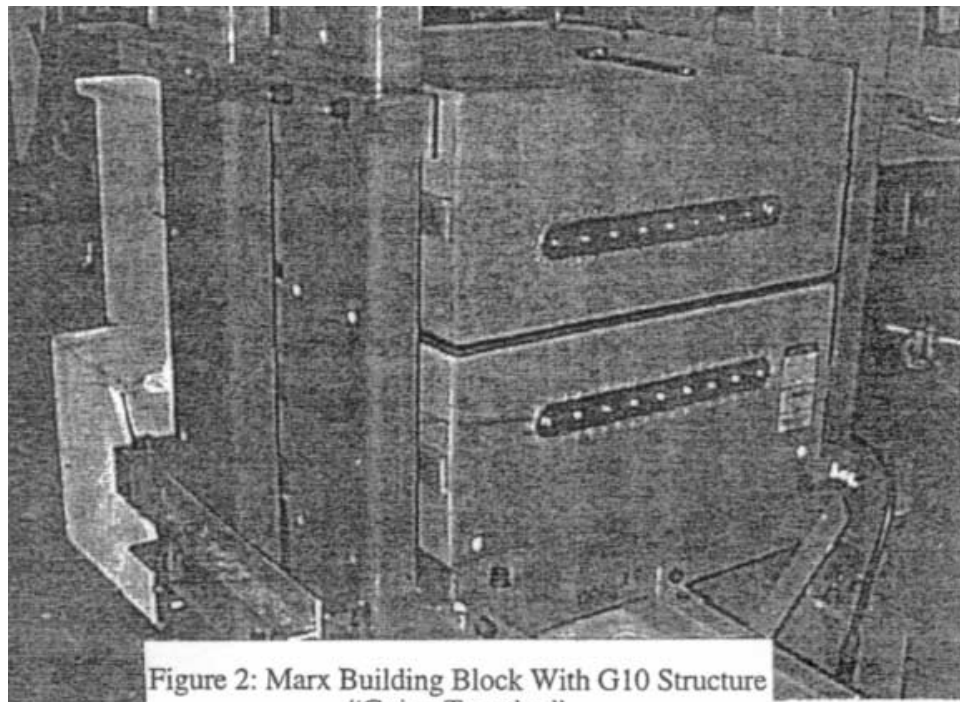
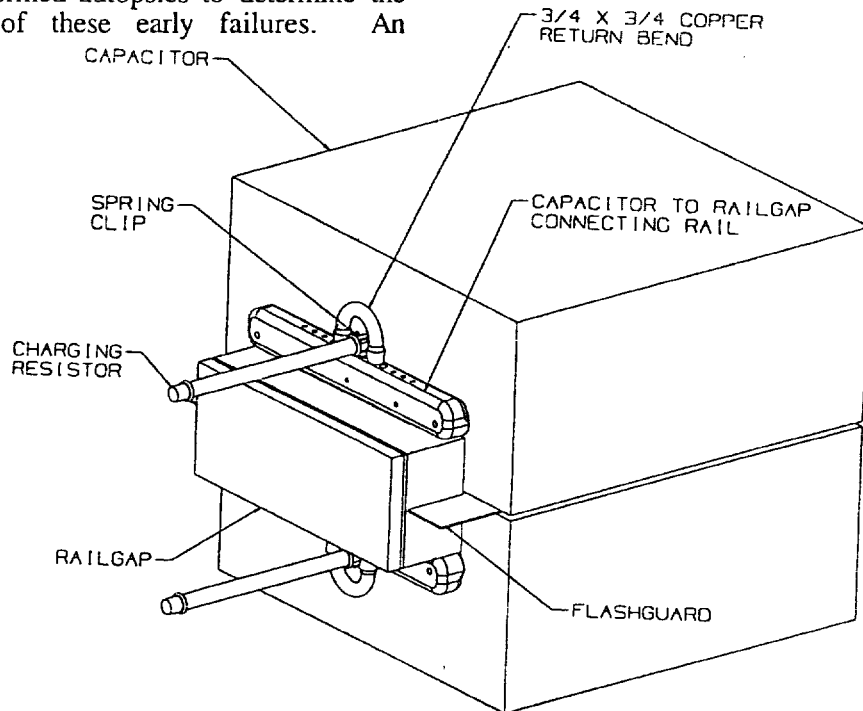

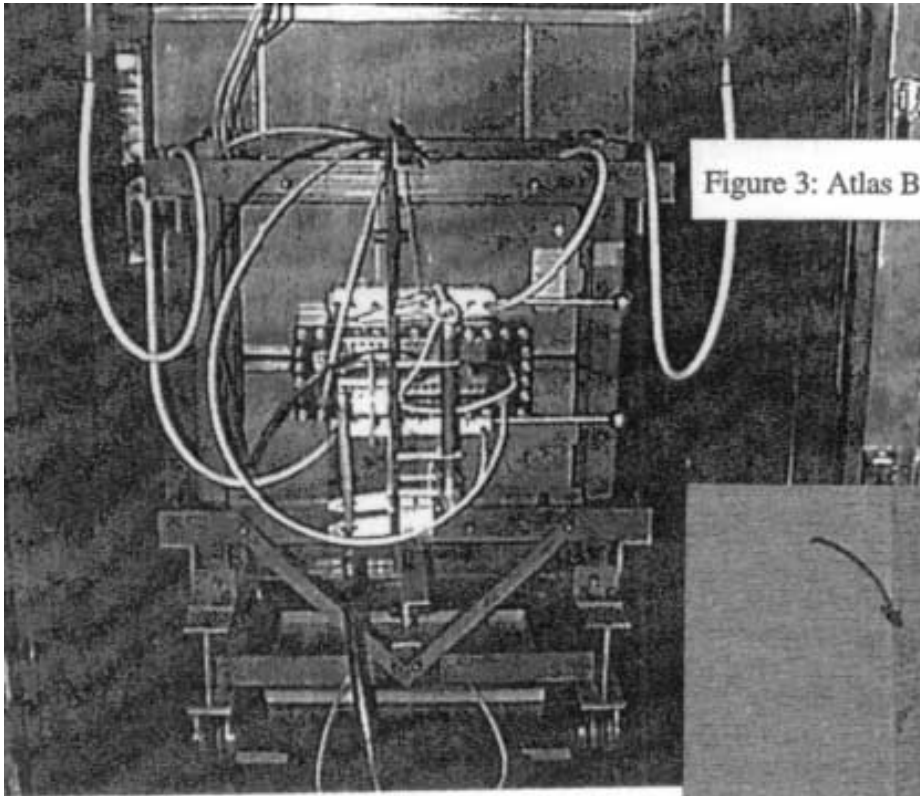

Figure 3: Atlas Building Block in Test Bay

Figure 4: Case Seam Failure in Fiberglass Case Paper-Foil Capacitor

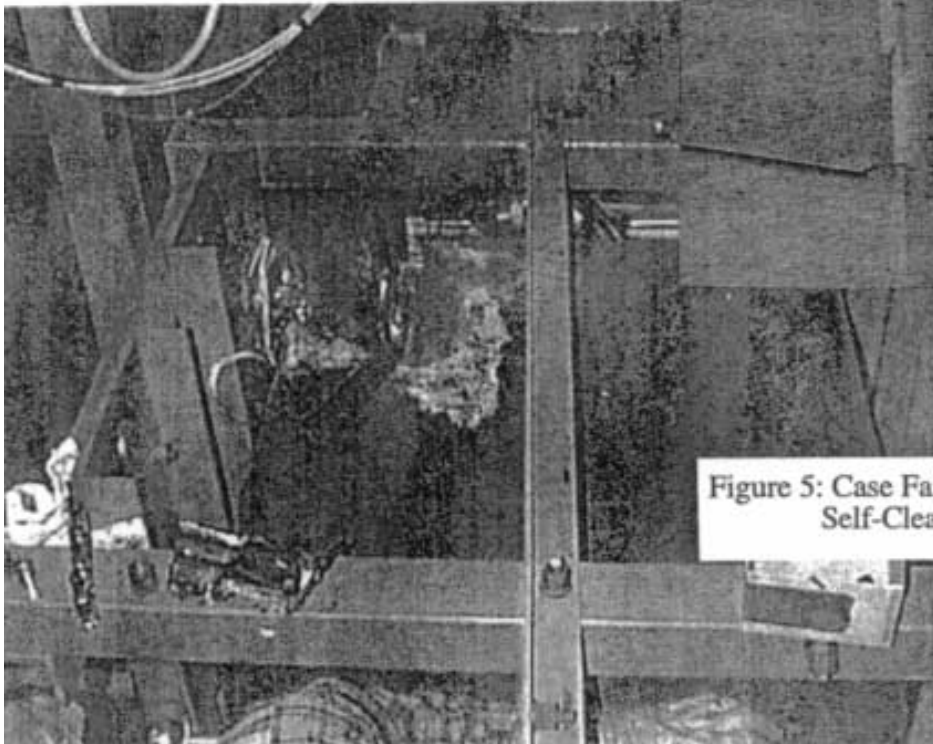
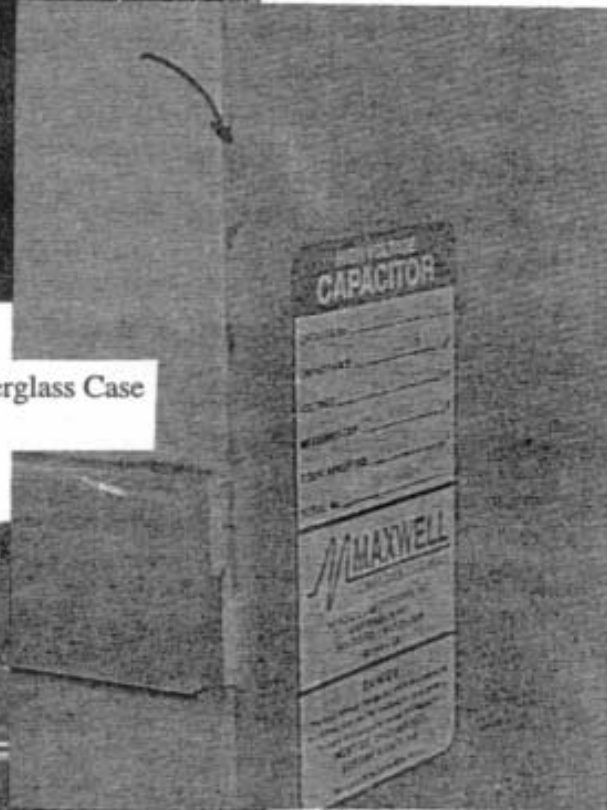

Figure 5: Case Failure in Fiberglass Case Self-Clearing Capacitor

encouraging result was that the capacitors failed in a rather benign fashion. The capacitors are manufactured with a square fiberglass tube with "end-caps". All failures generate an over pressure which ruptures the case seam as shown in Figure 4. The case is relatively weak and little pressure can accumulate before the seam is split. This result was not anticipated, as we expected a destructive case fault. The failures were also dull acoustically, with a rather low "thud."

The Aerovox Corporation provided two styles of capacitors for our evaluation, a self-clearing metalized paper and plastic dielectric design and the more conventional paper-foil and castor oil design. The self-clearing capacitors had a low yield of 31.9 uF and a high inductance of 28 nH. Unfortunately, this first design of self-clearing capacitors failed very quickly as shown in Table 3.

Table 3. Aerovox Self-Clearing Capacitor Failures

#1: 30 Shots at Full Atlas Parameters, 51 Total
#2: 103 Shots at Full Atlas Parameters, 123 Total

These capacitor failures also indicate a lifetime not suitable for Atlas use. Autopsies are being performed by Aerovox, Los Alamos, and Sandia Labs to determine the cause of these failures. These capacitors failed spectacularly, breaching the case, as shown in Figure 5. The acoustics of this failure was more typical of our occupation! It would seem most of the capacitor energy was deposited near the case wall. These cases are designed with five sides with a single lid, "on the top". This case design may cause a higher internal pressure before rupture. The test results clearly indicated that the self-clearing designs are still not mature for this high peak current application, even though individual sections were tested to their required parameters. Development and testing has been presently discontinued for Atlas use.

Aerovox also provided a paper-foil design with castor oil impregnant. This capacitor had a low yield of 31.8 uF and the lowest inductance of 15 nH. This capacitor design unfortunately had its first failure at 234 shots at full Atlas parameters and 281 total shots. More capacitors were not available to continue testing to determine if this failure was related to infant mortality.

IV. NEAR TERM PLANS

Within our present contract, we will continue the laborious testing program with paper-foil capacitors of improved manufacture. Both vendors have iterated the capacitor internal design topology and the fiberglass case fabrication technique. The

testing of the second round devices will begin in August. Many thousands of shots are required on many devices to determine the appropriate failure statistics. If neither vendor can provide adequate capacitors, bidding will then re-open to qualify additional suppliers.

V. CONCLUSION

It is surprising that the manufacture of a relatively low energy density capacitors (~5.7 J/cu-in), although physically large and heavy (~600 lbs), of conventional design, would be so difficult. It could be manufacturers are having a difficult time utilizing multiple full width papers (~26") and maintaining proper alignment, tolerance, and tension for the various foils and papers. The capacitor has over a million square inches of active dielectric cross-section. Earlier characterization of capacitor dielectric stress and lifetime may not scale as expected to these large areas. Additionally, earlier work on capacitor lifetime was probably characterized on "1.0" density paper. The higher density papers presently being used for pulse power capacitor manufacture may have slightly different characteristics to ensure their proper scaling laws. On a positive note, the capacitors have shown that reliable air operation (and therefore oil) is easily achievable with low current density contacts that permit reliable low inductance interconnects. Once the "second" round capacitors have been evaluated, hopefully a more meaningful (and appropriate) determination of lifetime characteristics will be achieved.