

# ENGINEERING DESIGN OF THE Z MAGNETICALLY-INSULATED TRANSMISSION LINES AND INSULATOR STACK

H. C. Ives and D. M. Van De Valde  
EG&G MSI, Box 9100, Albuquerque, NM 87119-9100

F. W. Long, J. W. Smith, R. B. Spielman, W. A. Stygar and R. W. Wavrik  
Sandia National Laboratories, Albuquerque, NM 87185-5800

R. W. Shoup  
Field Command Defense Special Weapons Agency, Kirtland AFB, NM 87117-5669

## ABSTRACT

A 3.3 m diameter cylindrical insulator stack and a set of 3 m diameter conical magnetically-insulated transmission lines (MITLs) were built for the Z accelerator. The 1.7 m tall stack operates at ~20 MA and 2.5-3.5 MV, and was instrumented with 12 current and 24 voltage monitors. The stack was designed to provide vertical stability for the MITLs and to resist radial buckling. The 22 crosslinked polystyrene insulators, 18 grading rings, 3 anode rings, and 2 cathode rings of the stack were concentrically and azimuthally aligned within  $\pm 0.75$  mm.

2-D and 3-D static finite element analyses (FEA) were used in designing the MITLs to limit gravity deflections to less than 0.25 mm. 2-D FEA dynamic analyses were done to predict motion and to help design features to restrict damage. Each MITL is divided into four concentric zones which fasten together in a way which facilitates fabrication, limits the extent of possible damage and allows for future changes at minimal cost. The tapered MITLs are supported by the stack electrode rings so that the gaps at small radius are adjustable from 0 to 22 mm. The MITL anodes were instrumented with 24 current monitors and have 48 additional diagnostic locations available. The MITLs were fabricated from 304L stainless steel except the outer anode sections, which were made from 6061-T6 aluminum alloy. Fabrication procedures were developed for the large and small diameter MITL cones, as well as for the stack electrode and grading rings. The power-flow surfaces were successfully machined to within  $\pm 0.25$  mm of the specified contours. A large, multi-trolley MITL handling system was designed to allow for removal, cleaning and replacement of the MITLs for each shot, at a shot rate of 1.5 shots/day. Additional equipment allows for cleaning of the insulators.

## INTRODUCTION

The Z accelerator<sup>1</sup> (previously called PBFA-II Z), like many other large machines, has evolved into its present configuration and size from the increasing desire for higher energy and power output. As the size of these machines has increased, however, the maintenance, fabrication and turnaround time challenges have also increased. These larger sizes also cause more fabrication difficulties, especially in the vacuum sections.

Z is approximately 33 m in diameter and 6.1 m high. The outermost portion consists of a circular array of 36 Marx generators submerged in oil. Between the oil section and the vacuum section of the machine is an annular water-filled zone containing intermediate storage capacitors, switches and transmission lines. The components are arranged in radial modules so that each Marx bank is connected to a water capacitor, switch set and transmission line. The central 3.6 m diameter portion of the machine consists of a vacuum insulator stack containing five 3 m diameter nested MITL electrodes (see Figure 1), a spacer tube, a diagnostic line-of-sight (LOS) ring, and upper and lower pumping chambers (see Figure 2). The electrodes are spaced vertically to create four MITLs which feed current toward the central load region<sup>2,3,4,5,6</sup>. At a radius 7.6 cm from the center, the currents of the four MITLs are added in parallel by a double-post-hole convolute. A single radial gap connects the output of the convolute to the z-pinch load.

## Report Documentation Page

Form Approved  
OMB No. 0704-0188

Public reporting burden for the collection of information is estimated to average 1 hour per response, including the time for reviewing instructions, searching existing data sources, gathering and maintaining the data needed, and completing and reviewing the collection of information. Send comments regarding this burden estimate or any other aspect of this collection of information, including suggestions for reducing this burden, to Washington Headquarters Services, Directorate for Information Operations and Reports, 1215 Jefferson Davis Highway, Suite 1204, Arlington VA 22202-4302. Respondents should be aware that notwithstanding any other provision of law, no person shall be subject to a penalty for failing to comply with a collection of information if it does not display a currently valid OMB control number.

1. REPORT DATE

**JUN 1997**

2. REPORT TYPE

**N/A**

3. DATES COVERED

-

4. TITLE AND SUBTITLE

**Engineering Design Of The Z Magnetically-Insulated Transmission Lines And Insulator Stack**

5a. CONTRACT NUMBER

5b. GRANT NUMBER

5c. PROGRAM ELEMENT NUMBER

6. AUTHOR(S)

5d. PROJECT NUMBER

5e. TASK NUMBER

5f. WORK UNIT NUMBER

7. PERFORMING ORGANIZATION NAME(S) AND ADDRESS(ES)

**EG&G MSI, Box 9100, Albuquerque, NM 87119-9100**

8. PERFORMING ORGANIZATION REPORT NUMBER

9. SPONSORING/MONITORING AGENCY NAME(S) AND ADDRESS(ES)

10. SPONSOR/MONITOR'S ACRONYM(S)

11. SPONSOR/MONITOR'S REPORT NUMBER(S)

12. DISTRIBUTION/AVAILABILITY STATEMENT

**Approved for public release, distribution unlimited**

13. SUPPLEMENTARY NOTES

**See also ADM002371. 2013 IEEE Pulsed Power Conference, Digest of Technical Papers 1976-2013, and Abstracts of the 2013 IEEE International Conference on Plasma Science. Held in San Francisco, CA on 16-21 June 2013. U.S. Government or Federal Purpose Rights License.**

14. ABSTRACT

**A 3.3 m diameter cylindrical insulator stack and a set of 3 m diameter conical magnetically-insulated transmission lines (MITLs) were built for the Z accelerator. The 1.7 m tall stack operates at 20 MA and 2.5-3.5 MV, and was instrumented with 12 current and 24 voltage monitors. The stack was designed to provide vertical stability for the MITLs and to resist radial buckling. The 22 crosslinked polystyrene insulators, 18 grading rings, 3 anode rings, and 2 cathode rings of the stack were concentrically and azimuthally aligned within  $\pm 0.75$  mm. 2-D and 3-D static finite element analyses (FEA) were used in designing the MITLs to limit gravity deflections to less than 0.25 mm. 2-D FEA dynamic analyses were done to predict motion and to help design features to restrict damage. Each MITL is divided into four concentric zones which fasten together in a way which facilitates fabrication, limits the extent of possible damage and allows for future changes at minimal cost. The tapered MITLs are supported by the stack electrode rings so that the gaps at small radius are adjustable from 0 to 22 mm. The inner anodes were instrumented with 24 current monitors and have 48 additional diagnostic locations available. The MITLs were fabricated from 304L stainless steel except the outer anode sections, which were made from 6061-T6 aluminum alloy. Fabrication procedures were developed for the large and small diameter MITL cones, as well as for the stack electrode and grading rings. The power-flow surfaces were successfully machined to within  $\pm 0.25$  mm of the specified contours. A large, multi-trolley MITL handling system was designed to allow for removal, cleaning and replacement of the MITLs for each shot, at a shot rate of 1.5 shots/day. Additional equipment allows for cleaning of the insulators.**

15. SUBJECT TERMS

16. SECURITY CLASSIFICATION OF:			17. LIMITATION OF ABSTRACT <b>SAR</b>	18. NUMBER OF PAGES <b>6</b>	19a. NAME OF RESPONSIBLE PERSON
a. REPORT <b>unclassified</b>	b. ABSTRACT <b>unclassified</b>	c. THIS PAGE <b>unclassified</b>			

**Standard Form 298 (Rev. 8-98)**  
Prescribed by ANSI Std Z39-18

## INSULATOR STACK

The insulator stack consists of 22 insulators, 18 grading-rings and five stack electrode rings which are arranged to form four modules (see Figure 1). The top two modules each have five insulators and four grading-rings, and the bottom two each have six insulators and five grading-rings (due to the higher voltage). The aluminum stack electrode rings attach to field-shaping transition rings in the water section to which the bi-plate water-section transmission lines are affixed. The central grading-rings of the lower two modules have flux-excluding rings attached that project into the water to help distribute the electric field. Extensive design iterations were done to keep the vacuum-side fields uniform and to minimize the fields at the cathode triple points and grading-ring tips<sup>4,7,8</sup>. The bi-plates are spaced 14 cm apart and have 5 cm rolled edges to optimize the field shaping near the attachment points, as well as throughout the water section<sup>9</sup>. Each insulator-stack module has three current monitors and six voltage monitors placed in the anode stack electrode ring, all spaced 40° apart<sup>10</sup>.

The new Z insulator ring design was analyzed to insure against inward buckling. Additional data were used from the original studies<sup>11</sup> and failure tests that were done for the PBFA-II insulators, since these were structurally the same design<sup>12</sup>. Finite element analyses were also done to verify acceptable stress levels in the insulators during assembly and clamping. The new rings were made of Rexolite™ crosslinked polystyrene due to its superior flash-over resistance, low water absorption and good dimensional stability. Care was exercised during the design to assure the total weight of the entire assembly (including the attached flat plates) was within the 9100 kg crane limit, so that the assembly could be installed as a single module.

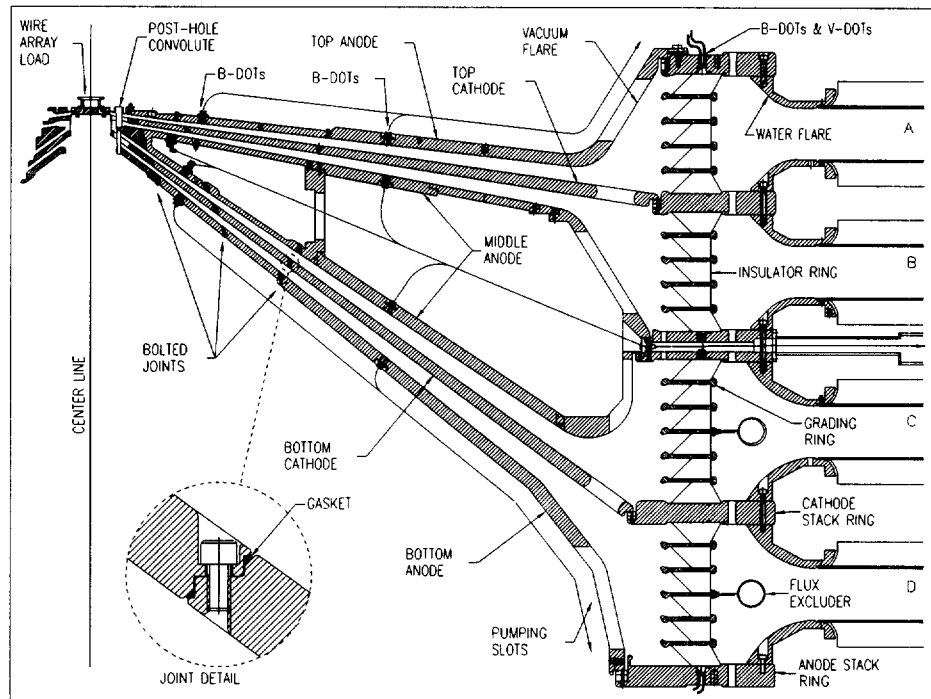

**Figure 1. Z MITLs and insulator stack.**

Fabrication of the stack components was done at various facilities. Machining of the insulator rings was performed by the supplier<sup>13</sup> of the Rexolite™ material and was done horizontally by high speed milling in the free state (unclamped). Distortion from clamping and cutting tool forces was virtually eliminated and an 80 micron (RMS) smoothness was achieved on all surfaces .

The new grading-rings were made from seamless rolled rings of 6061-T6 aluminum and were hard anodized after machining. The rolled-ring construction was specified to help reduce non-axisymmetric warping which could result from machining across non-axisymmetric stresses on thin welded plate sections. Some axisymmetric warping was encountered during machining but was corrected by frequent inversion of the part during lathe cutting<sup>19</sup>. Our material specification was subsequently updated to 6061-T651, in which a final post-quench stretch-forming is required to reduce the warping problem. The hard anodizing was used to inhibit electron emission and does not appear to be suffering damage or causing a significant outgassing problem (at  $\sim 10^{-6}$  torr).

The stack electrode rings ranged in thickness from 6-9 cm and were machined from three-piece weldments of 6061-T6 aluminum plate<sup>14</sup>. The rings were subsequently chromate coated, with nickel plating applied to electrical contact interfaces using a specialized on-site electroplating technique<sup>20</sup>.

The insulator stack rests on a large 3.4 m diameter stainless-steel support tube<sup>19</sup> which is attached atop the lower vacuum pumping chamber at the floor of the water section. The LOS ring<sup>15</sup> is supported by the insulator stack, which is in turn surmounted by an upper vacuum pumping chamber and lid (see Figure 2). Nine tensioning rods (not shown) clamp the insulator stack between the LOS ring and the floor, so that the seals are compressed under 1.2 MN at all times. The components of the entire vacuum chamber assembly have been analyzed to account for this load in addition to the external pressure due to the vacuum and the hydrostatic load from the the water.

### MITLs

**DESIGN.** There are five MITL electrode assemblies which define four vacuum transmission lines. Each electrode assembly is constructed in four annular parts: an outer cone and three inner cones, each of successively smaller diameter (see Figure 1). This system of annular zones allows for damage mitigation in the event of severe power-flow accidents: only the affected inner parts need be replaced or repaired, rather than the entire MITL. In addition, the inner cone parts may be modified considerably for experimental reasons in the future at substantially less expense than a larger, monolithic construction would allow. Stainless steel was chosen for all the MITL material (except for the outer anodes) to obtain uniform electron emission from the cathodes<sup>16</sup> and for damage repair considerations. Aluminum alloy was used for the outer anodes to keep the total weight of the five MITL electrodes within the crane load limit. The mechanical junctions between cones are made with recessed screws and the power-flow surfaces are connected electrically with recessed copper gaskets (see detail in Figure 1) which are easily replaced and protect the mating surfaces from arc damage. Various types of copper alloy helical gaskets were tried, but solid pure copper wire is currently being used. The cone assemblies rest at their perimeter (without fasteners) on shims which are attached to the inner edge of the stack electrode rings. The shims allow for 0-22 mm anode-cathode gap adjustment and use elastic copper alloy spiral gaskets<sup>17</sup> to form the electrical connection.

Current monitor locations are distributed every 40° on two radii of the four MITL anode surfaces for a total of 72 possible sites; 24 monitors are routinely fielded. Additional monitors have been located ~4-6 cm from the center of the z-pinch load<sup>10</sup>.

Numerous finite element calculations were done to determine stress and deflection of the cones as a function of weight and

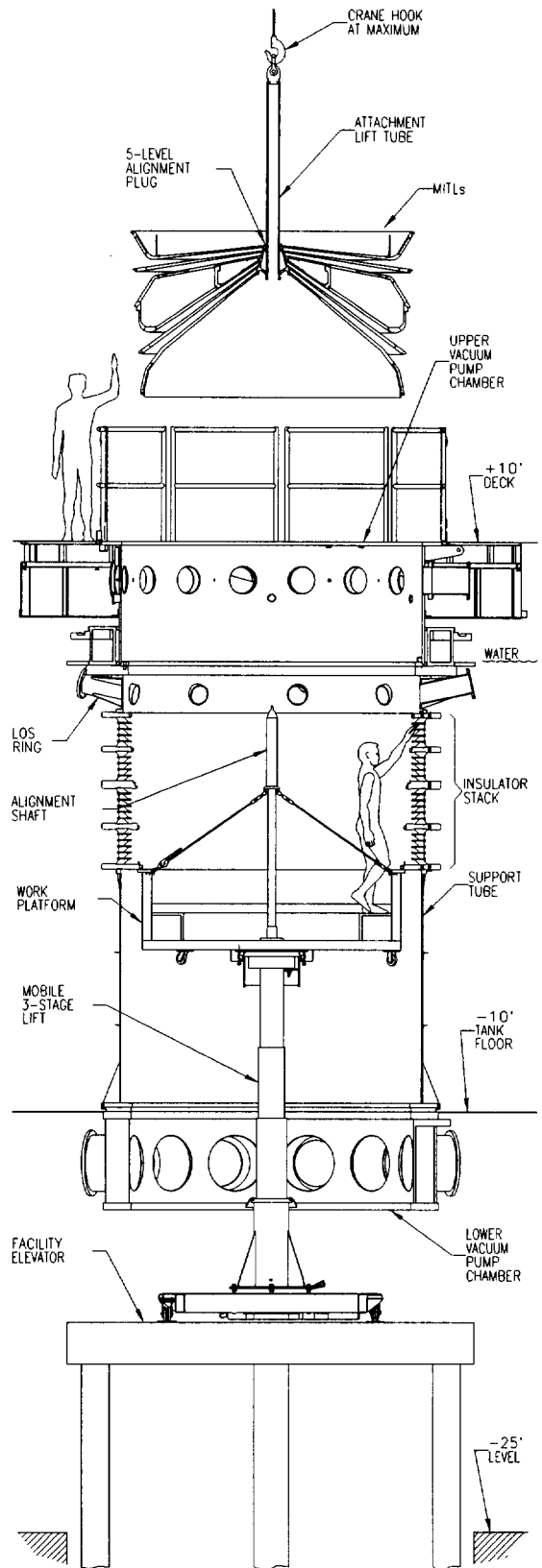

Figure 2. Vacuum stack equipment.

$$p(r) = \mu_0 \frac{I^2}{8\pi^2 r^2} \text{ Pa} \quad (\text{ref. 18})$$

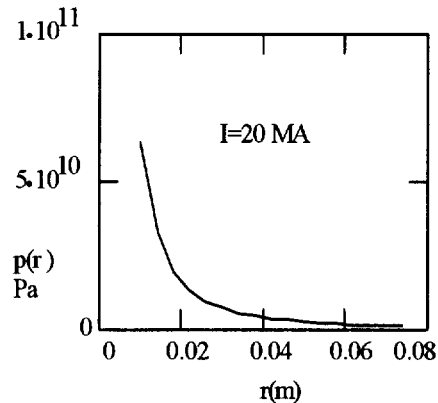

Figure 3. Magnetic pressure within 7.5 cm.



Figure 4. Typical damage to load region.

various installation scenarios. Simple calculations indicate the magnetic field pressure within the post-hole convolute region of the MITLs (see Figure 3) is high enough to cause severe local destruction if sustained long enough (see Figure 4). Currents on the order of 10-20 MA crowbarred into the MITLs (after the insulator stack flashes) may only have to be there for a microsecond to do significant damage. Surface heating due to extreme current densities may also be a contributing factor to the destruction. Calculations indicate the MITL assemblies (out to 3 m in diameter acting as a single mass) should not move much, although they appear to be moving significantly (sometimes jumping vertically up to 3 cm). The MITL movement is still under investigation and could be caused by mechanical shock from the water-section self-break switches, which can be felt in buildings 300 meters away. Since the impulse loading and possible arc damage severity on the MITL surfaces were not well known during the design of the accelerator, every effort was made to maximize the strength, stability and reparability of these parts within the confines of prudent power-flow constraints and basic practicality.

**FABRICATION.** Complete fabrication of the outer cones was managed through one large, integrated facility<sup>19</sup>. The outer top and bottom anode cones were each fabricated from 5.0-6.3 cm thick 6061-T6 aluminum plate which was cut into three arc-shaped sections for each cone, and annealed (to the "O" condition). The flat arc sections were formed into 120° conical sectors, trimmed and then welded together into a complete cone using high strength 4643 heat-treatable weld-filler metal. The middle outer anode MITL is hollow with a removable cover and ports, and was thus considerably more complex to fabricate. Each aluminum cone weldment was checked for cracks (ultrasonically) and straightness before solution heat treatment (to the "W" condition). The shape was again checked after the heat treatment and adjustments were made as necessary. Rough machining was carried out on large vertical lathes and necessitated repeated alternate-side machining in order to control warping. After rough machining, the cones were heat treated to the T6 condition to stabilize the metal and gain strength before final machining was completed. A machining tolerance of  $\pm 0.25$  mm was achieved for the outer power-flow surfaces. Nickel plating was applied to the aluminum on the electrical contact interfaces and in the diagnostic holes<sup>20</sup>. No evidence of delamination has been observed on these surfaces after >80 shots. The outer MITL cathodes were made of 5.0-6.3 cm thick 304L stainless steel plate which was cut, annealed, formed, re-annealed and then welded into cones as described above. Following that, a final anneal was done at  $1040^\circ\text{C} \pm 14^\circ\text{C}$  for 2 hours and cooled in still air to minimize generation of internal stresses. [This procedure is not recommended for parts highly stressed under static loads, those used in a corrosive environment or those made from plain 304 alloy.] The shallower upper cone was the more problematic to machine due to its unstable shape and sensitivity to internal stresses: our second attempt was successful and yielded the heat treatment process described above.

The remaining MITL parts (within 1.3 m diameter) were fabricated at other facilities. The cones were made from 304L stainless<sup>21</sup> and followed a similar heat treating process (above) when possible. The shallowest of these cones

(less than 10 cm height) were machined from single pieces of solid plate. The replaceable post-hole convolute parts<sup>22</sup> are also 304L stainless and are electropolished and selectively plated with 3 microns of gold.

### MITL HANDLING EQUIPMENT

When Z is fired, the load parts and the central upper two smallest MITL parts near the load are blown into fragments and partially vaporized due to high transient surface pressures and temperatures (see Figure 4). As a result, debris scatters throughout the system, metal spatter is fused to MITL surfaces, and vaporized metal condenses on surfaces as far out as the insulators. In order to properly refurbish all the surfaces and clean the insulator stack, it is necessary to remove all the MITLs after every shot. In anticipation of this scenario, equipment was designed and built for the removal, cleaning and replacement of the MITLs so that 1.5 shots/day could be routinely achieved. Since the MITLs are ~3 m in diameter and have a total mass of approximately 7300 kg, the handling equipment must be concomitantly large and heavy as well.

The equipment consists of three major items: 1) a set of crane-lift attachments for moving the MITLs, 2) a hydraulic lower vacuum stack platform (see Figure 2), and 3) a rack system for receiving, rotating and dispersing the MITLs for personnel access (see Figure 5). The lift attachments are designed so that the MITLs may be moved between the receiving rack and the accelerator individually, all together, or two and three at a time. These combinations allow for choosing the most efficient method, depending on the extent of misalignment and damage to the MITLs after a shot, and whether or not current diagnostics were used in the middle anode (see Figure 1). The lift attachment design also insures that the MITLs are centered within the insulator stack before final placement by guiding them on an alignment shaft attached to the lower vacuum-stack work platform (see Figure 2). This hardware assures concentricity of the MITLs within the stack to  $\pm 3$  mm as a group and to within  $\pm 0.25$  mm relative to each other (near the center). Fine adjustments of the upper MITL provide a radial gap at the load routinely within  $\pm 0.1$  mm. Close tolerances and dowel pins at all fastener interfaces assure consistent rotational position and A-K gap control. Shims fastened to the five stack electrode rings allow adjustment of the four A-K gaps to within  $\pm 0.2$  mm.

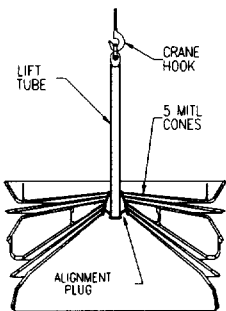

The lower vacuum-stack work platform is affixed to the top of a compound hydraulic lift which is in turn positioned on a large floor elevator. The platform and lift system provide sufficient range for personnel access for cleaning the insulators, for positioning the MITLs and for various other tasks.

The rack system is designed to provide a time efficient means for cleaning and refurbishing the MITLs between shots. The MITLs are placed by the crane into carts which are held in a large rack in the same order in which they are removed from the accelerator. After the MITLs are latched in place, a large hydraulic system rotates the rack so the carts may be manually rolled out onto tracks on the bay floor with

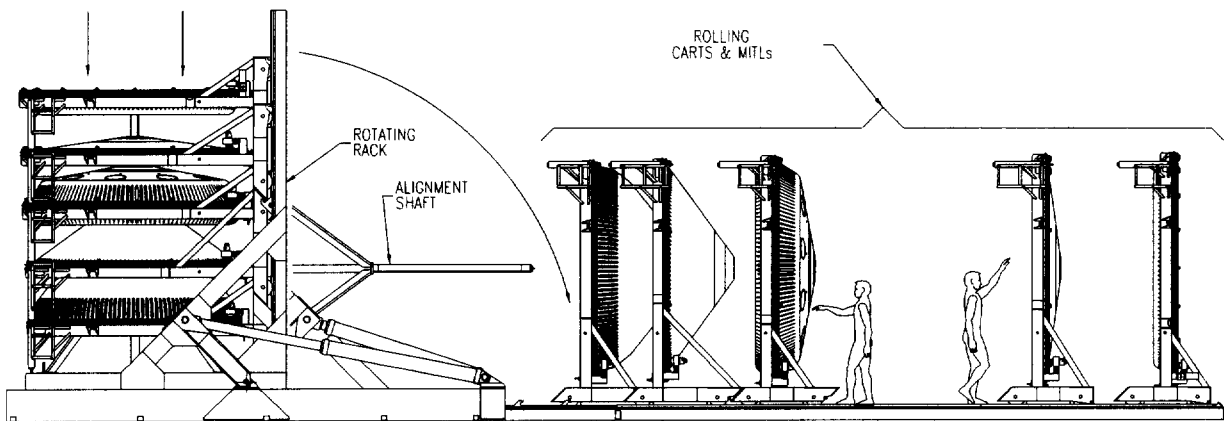

Figure 5. Rack and cart system for refurbishing MITLs.

sufficient space in between to allow personnel access. Each cart is equipped with an air-motor drive to rotate the MITL electrode about its axis so that the entire surface area may be within reach of personnel standing on the floor deck. Abrasive scouring and solvent cleaning requires about 1.5 hours with 4 people working concurrently. After cleaning and part replacement, the carts are rolled back into the rack which is then rotated back to its original position. The MITLs are picked up with the crane attachments and returned to the accelerator.

## CONCLUSIONS

Fabrication and operational difficulties of large accelerators increase with the mass, size and required dimensional stability of the components. The robust design approach used for Z has provided a stable MITL system with predictable and acceptable maintenance levels. Although the Z parts were not trivial to build, neither are they yet at the limits of production. Extrapolation of the trend toward larger machines, however, may soon require further modularization concepts to keep components manufacturable, transportable, and low-risk in operation.

Turnaround time, while a function of size, is also strongly driven by the positional accuracy and cleanliness needed relative to the damage and debris generated. These variables will determine the extent of ancillary equipment needed for removal, refurbishment, replacement and positioning of components for efficient operation. Early inclusion of such equipment into the design of Z has helped assure an integrated system capable of 1.5 shots/day.

## ACKNOWLEDGEMENTS

The authors would like to extend thanks to D. M. Heath, L. V. Wilson, R. L. Williams, J. W. Kellogg, M. D. Pelock, A. P. Seth, and C. E. Guthrie of the Hardware Development and Application Department for their past and continuing efforts in this project. In addition, we would like to thank C. A. Macias, José Padilla and especially R. L. Brockman<sup>19</sup> for their contributions. Z would not have been possible without their sustained and concerted efforts.

This work was supported by the United States Department of Energy under contract DE-AC04-94AL85000. Sandia is a multiprogram laboratory operated by Lockheed Martin for the US DOE.

- 
- [1] R. B. Spielman, et al., "Pulsed Power Performance of PBFA-Z," these proceedings.
  - [2] W. A. Stygar et al., "Design and Performance of the Z Magnetically-Insulated Trans...", these proceedings.
  - [3] P. A. Corcoran et al., "PBFA-Z Vacuum Section Design Using TLCODE Simulations," these proceedings.
  - [4] I. D. Smith et al., "Design Criteria for the PBFA-Z Insulator Stack," these proceedings.
  - [5] K. W. Struve et al., "Circuit-Code Modeling of the PBFA Z for Z-Pinch Experiments," these proceedings.
  - [6] D. B. Seidel and C. W. Mendel, "Three Dimensional Simulation of Current Adders...", these proceedings.
  - [7] R.W. Shoup et al., "Design Validation of the PBFA-Z Vacuum Insulator Stack," these proceedings.
  - [8] M. A. Mostrom and T. P. Hughes, "Ivory PIC Simulations of PBFA Z Insulator Stack," these proceedings.
  - [9] R. J. Garcia et al., "Waterline Design and Performance of PBFA-Z," these proceedings.
  - [10] W. A. Stygar et al., "V-dot and B-dot Monitors for Z Vacuum-Section Power-Flow ...," these proceedings.
  - [11] L. O. Seamons, "PBFA-II Insulator Stack Design...", Proc. of 5<sup>th</sup> IEEE Pulsed Power Conf., pp. 814-7, 1985
  - [12] R. Sears, R. Altes and I. Smith, "Deflection Testing of One-Eighth Scale PBFA-II Tube Insulator," PSI-IR-156-2, Dec. 1983, for Sandia National Laboratories by Titan/PSI, 600 McCormick St., San Leandro, CA 94577
  - [13] C-Lec Plastics, Inc., 5301 Tacony St., Bldg. 120, Philadelphia, PA 10137
  - [14] Remmele Engineering, Inc., 17465 US Hwy. 10 E., Big Lake, MN 55309
  - [15] Victoria Machine & Fab., 1309 E. Commercial, Victoria, TX 77901
  - [16] D. H. McDaniel, private communication
  - [17] Spira Mfg. Corp., 12721 Saticoy St. S., North Hollywood, CA 91605
  - [18] D. Halliday & R. Resnick, Fundamentals of Physics, J. Wiley & Sons, Inc., 1970, p. 606
  - [19] Votaw Precision Technologies, Inc., 13153 Lakeland Rd., Santa Fe Springs, CA 90670
  - [20] Platron, 100 North Hill Dr., Unit 37, Brisbane, CA, 94005
  - [21] Continental Machine Co., Inc., 6824 Washington NE, Albuquerque, NM 87109
  - [22] Gull Group, 777 Bay St.- Suite 7, San Francisco, CA 94109