

J.R. Greig, D.P. Murphy, R.E. Pechacek, M. Raleigh, E. Laikin, and S. Hauver

Experimental Plasma Physics Branch
 Plasma Physics Division
 Naval Research Laboratory
 Washington, DC 20375

ABSTRACT

Laser guided, electric discharges in the atmosphere have been used to create ~1m long, air plasma channels and have enabled experiments to study channel cooling and the interaction of intense relativistic electron beams (REB) with channels in the atmosphere. These discharges require driving potentials >100kV to follow the laser designated path, but only modest stored energy: typically <1000J and ~250kV were used. Some applications used two stage discharges wherein a second, lower voltage capacitor bank was discharged into the air plasma channel. The secondary discharges were tailored for each application which included: channel resistance measurements; the generation of an RF plasma antenna; simulation of nuclear explosion induced lightning (NEIL); and studies of relativistic electron beam propagation in current carrying channels. We describe the different systems used to effect these discharges and consider the design of a system necessary to extend the discharge length to ~10m.

INTRODUCTION

Partially conducting, reduced density channels in the atmosphere can be produced along predictable paths by high energy focused laser beams[1,2]. A high voltage electric discharge will follow the path the laser designated channel and provide a systematic method for studying such phenomena as channel cooling,[3] long duration discharges for nuclear explosion induced lightning (NEIL) simulation, and the interaction of an intense relativistic electron beam (REB) with channels in the atmosphere[4]. The highly conductive afterglow plasmas have also been used as radio frequency antennas to transmit and receive information.[5] Most of these applications used a two stage discharge system[6]. The primary discharge requires driving potentials of the order of 100kV per meter of channel to follow the laser designated path but only modest stored energy. This was provided by a compact Marx generator (a parallel charged, series discharged capacitor bank) with typically <1000J stored energy and a peak output voltage of ~250kV. The secondary discharge was provided by separate lower voltage capacitor banks that were chosen for each application. The secondary capacitor bank was isolated from the primary discharge by a simple inductor (see figure 1) when long duration (~1ms) discharges were

required or by a normally open, explosively closed, low inductance, solid dielectric switch (see figure 2) when short duration (<100 us) discharges were required.

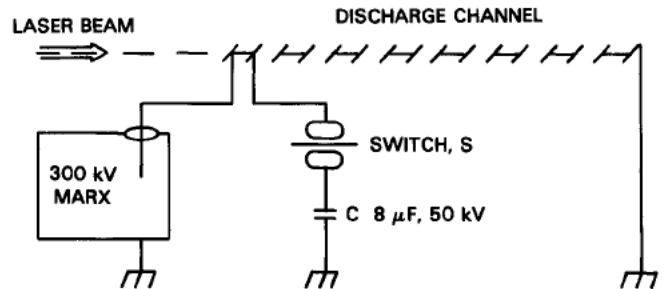

Figure 2. Schematic diagram of the apparatus for producing discharge channels with explosive switch isolation of the secondary bank.

The explosively closed switch is capable of holding off over 300kV. Preliminary testing has been conducted on a new version of the explosive switch that can isolate a secondary bank from a primary discharge of more than 1MW that will be required to produce ~10m long channels in the air.

APPARATUS

As indicated in figure 3, the path of the laser guided electric discharge is designated by the focused beam from a Nd:glass laser. This laser typically

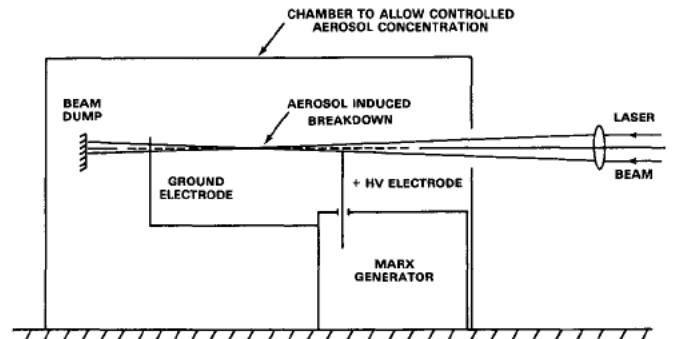

Figure 3. Arrangement for preparing channels in the atmosphere.

delivers 60J in 40ns at 1.06 μm wavelength. The laser-atmosphere interaction is enhanced by the presence of a light smoke (<10⁻⁷ gm/cm³) which is created by burning a small quantity of black gunpowder in the experimental enclosure. Within the diameter of the laser beam, the aerosol-initiated air-breakdown produces randomly spaced plasma beads and sufficiently perturbs the atmosphere to guide an electric discharge along the laser path. The laser energy absorbed in this preionized channel is ~15J/m. A compact, five stage Marx generator with effective capacitance of 0.016μF provides the primary high voltage discharge, typically ~250kV. The delay between firing the Nd:glass laser and triggering the Marx generator is always 30 μs, and electrical breakdown occurs immediately (<100ns). For 1m long guided discharges the

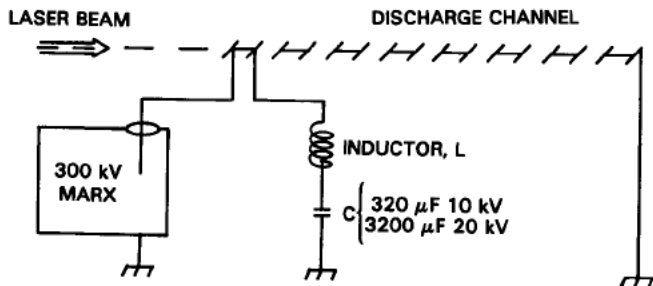

Figure 1. Schematic diagram of the apparatus for producing discharge channels with inductive isolation of the secondary bank.

Report Documentation Page

Form Approved
OMB No. 0704-0188

Public reporting burden for the collection of information is estimated to average 1 hour per response, including the time for reviewing instructions, searching existing data sources, gathering and maintaining the data needed, and completing and reviewing the collection of information. Send comments regarding this burden estimate or any other aspect of this collection of information, including suggestions for reducing this burden, to Washington Headquarters Services, Directorate for Information Operations and Reports, 1215 Jefferson Davis Highway, Suite 1204, Arlington VA 22202-4302. Respondents should be aware that notwithstanding any other provision of law, no person shall be subject to a penalty for failing to comply with a collection of information if it does not display a currently valid OMB control number.

1. REPORT DATE JUN 1985	2. REPORT TYPE N/A	3. DATES COVERED -	
4. TITLE AND SUBTITLE Pulsed Power Considerations For Laser Guided Discharges And Their Applications		5a. CONTRACT NUMBER	
		5b. GRANT NUMBER	
		5c. PROGRAM ELEMENT NUMBER	
6. AUTHOR(S)		5d. PROJECT NUMBER	
		5e. TASK NUMBER	
		5f. WORK UNIT NUMBER	
7. PERFORMING ORGANIZATION NAME(S) AND ADDRESS(ES) Experimental Plasma Physics Branch Plasma Physics Division Naval Research Laboratory Washington, DC 20375		8. PERFORMING ORGANIZATION REPORT NUMBER	
9. SPONSORING/MONITORING AGENCY NAME(S) AND ADDRESS(ES)		10. SPONSOR/MONITOR'S ACRONYM(S)	
		11. SPONSOR/MONITOR'S REPORT NUMBER(S)	
12. DISTRIBUTION/AVAILABILITY STATEMENT Approved for public release, distribution unlimited			
13. SUPPLEMENTARY NOTES See also ADM002371. 2013 IEEE Pulsed Power Conference, Digest of Technical Papers 1976-2013, and Abstracts of the 2013 IEEE International Conference on Plasma Science. Held in San Francisco, CA on 16-21 June 2013. U.S. Government or Federal Purpose Rights License.			
14. ABSTRACT Laser guided, electric discharges in the atmosphere have been used to create -1m long, air plasma channels and have enabled experiments to study channel cooling and the interaction of intense relativistic electron beams (REB) with channels in the atmosphere. These discharges require driving potentials >100kV to follow the laser designated path, but only modest stored energy: typically <1000J and -250kV were used. Some applications used two stage discharges wherein a second, lower voltage capacitor bank was discharged into the air plasma channel. The secondary discharges were tailored for each application which included: channel resistance measurements; the generation of an RF plasma antenna; simulation of nuclear explosion induced lightning (NEIL); and studies of relativistic electron beam propagation in current carrying channels.			
15. SUBJECT TERMS			
16. SECURITY CLASSIFICATION OF:			17. LIMITATION OF ABSTRACT SAR
a REPORT unclassified	b ABSTRACT unclassified	c THIS PAGE unclassified	
			18. NUMBER OF PAGES 4
			19a. NAME OF RESPONSIBLE PERSON

current in the discharge rises sinusoidally to a maximum of $\sim 10\text{kA}$, oscillates with a period of $\sim 3\mu\text{s}$, and damps to $<1\text{kA}$ in three periods. The energy deposited in the hot air column is $\sim 350\text{J/m}$. At a time $\sim 30\mu\text{s}$ after firing the Marx generator, a long, straight, reduced-density channel has formed. The channel has reached pressure equilibrium with the atmosphere around it but is more highly conducting than thermal equilibrium at this temperature. Once the primary discharge has begun, different secondary banks can be discharged along the same path (see figure 4).

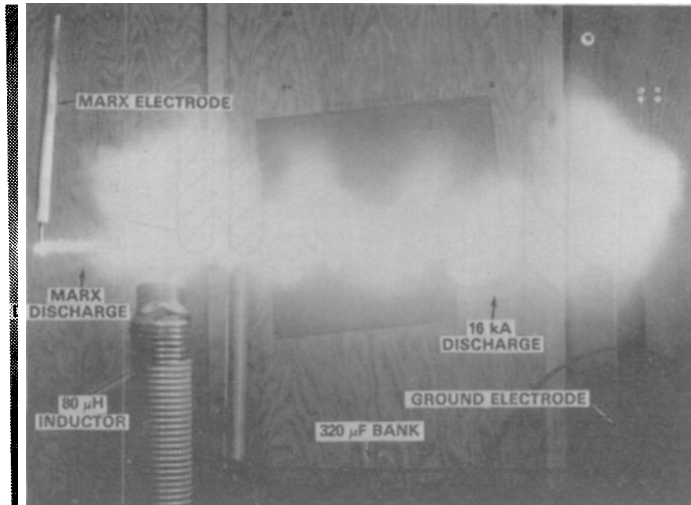

Figure 4. Photograph of a 16kA discharge in the test chamber.

The detonator activated, solid dielectric switch, depicted in figure 2, closes (on command) $\sim 30\mu\text{s}$ after triggering the Marx generator, when conditions formed by the primary discharge are varying slowly. The switch was housed in a plastic tank 60cm on a side. Six sheets of 0.5mm thick polyethylene, 40cm on a side, separated the upper and lower electrodes of the switch. The tank was filled with SF_6 gas at atmospheric pressure to suppress flashover around the polyethylene sheets. Figure 5 shows pre- and post-closure views of the switch. During the primary discharge, before the switch closes, it is subjected to a peak voltage stress of $V(\text{primary}) \pm V(\text{secondary})$, depending on the polarity of the secondary bank. After the primary discharge has decayed, the upper switch electrode is connected to ground through the air plasma column so that when the switch closes the voltage across it is just that of the secondary bank. To close the switch,

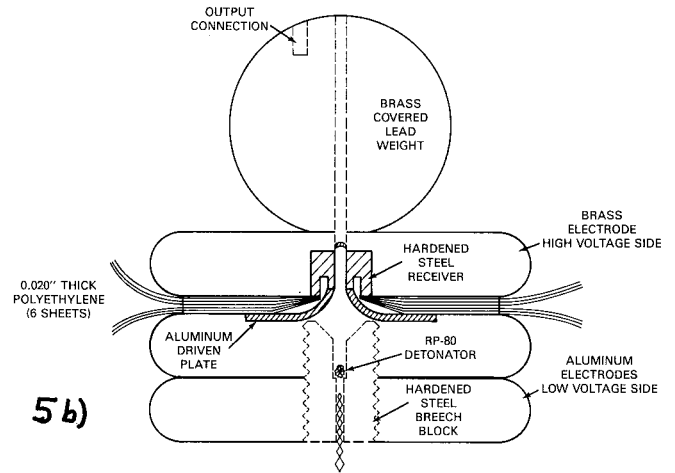
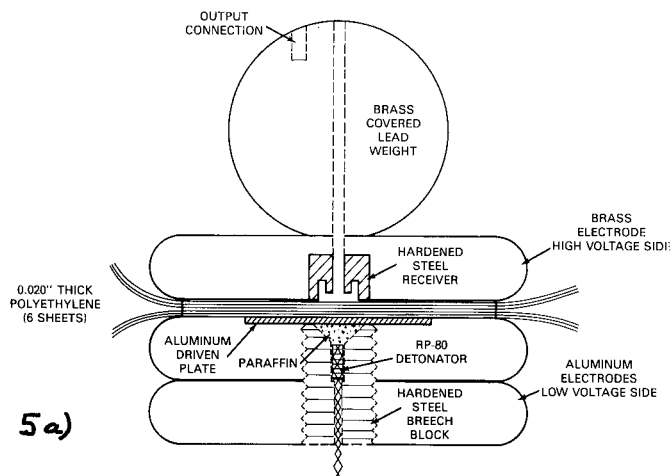

Figure 5. Schematic diagram of the explosively closed, solid dielectric switch a) before closure and b) after closure.

an RP-80 exploding bridgewire (EBW) detonator, mounted inside the lower electrode, is triggered and drives a 3mm thick aluminum plate from the lower electrode through the polyethylene sheets to contact the top electrode. The paraffin sandwiched between the detonator and the driven plate provides a pressure transfer medium to couple the shock wave generated by the detonator to the aluminum plate. After the shot the polyethylene sheets and the aluminum driven plate are replaced. The hardened steel breech block is reloaded with a new detonator and paraffin. The turnaround time of the switch is reduced to about 5 minutes if several breech blocks are kept loaded and ready. The trigger pulse is supplied through an oil-insulated, isolating transformer because the switch and detonator assembly "float" electrically with the high voltage side of the secondary bank during the charge cycle. The switch closes $\sim 22\mu\text{s}$ after the trigger pulse to the detonator (see figure 6).

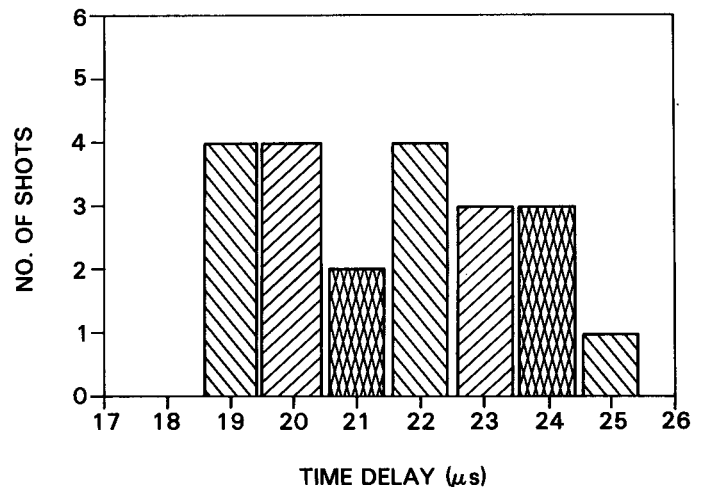

Figure 6. Histogram of the time delay between trigger and closure for the explosively closed, solid dielectric switch shown in figure 5.

APPLICATIONS

Experiments on channel cooling and REB interaction with reduced density channels were carried out with the primary discharge that is depicted in figure 3. At $\sim 100\mu\text{s}$ after the initiation of the primary Marx discharge the plasma column has achieved approximate thermal equilibrium at a temperature of $\sim 5000\text{K}$, an electron density of $\sim 10^{14}/\text{cm}^3$, an on axis gas density $\sim 1/20$ of normal atmospheric density, and a radius of

-1cm . Time-resolved, multiframe schlieren photography of the channel shows that it cools by turbulent convective mixing of cold outside air into the hot reduced density channel.[3]

When a 1MeV, 16kA, 40ns long REB pulse was injected into a hot discharge channel to study REB/channel interaction, it induced a plasma current to flow in the channel in the opposite direction to that of the REB current. The magnetic repulsion of these counterflowing currents ejected the REB from the region of the channel. This effect was most pronounced at early times when the discharge channel was hot and conductive but it decreased in intensity until by $\sim 350\mu\text{s}$ the motion of the REB was indistinguishable from that when it was injected into ambient air. For these experiments it must be remembered that there was no residual discharge current flowing in the channel when the REB pulse was injected.

The phenomenon of NEIL was observed at the IVY-MIKE above ground, thermonuclear test in 1952[7] and has remained somewhat of a mystery for many years[8]. To effect a laboratory simulation of NEIL the circuit shown in figure 1 was used. Two different secondary banks, a $320\mu\text{F}$ bank charged to 10kV and a $3200\mu\text{F}$ bank charged to 10kV or 20kV provided discharges with peak currents of 16kA, 50kA, and 100kA respectively and periods up to 2ms. Even so these discharges were not as bright[9] nor as long lasting as the NEIL discharges.

The circuit shown in figure 2, with the explosively closed, solid dielectric switch, has been used in several experiments. The channel resistance per unit length was determined using a $1200\mu\text{F}$ secondary bank charged to 400V.[6] While the primary discharge current is flowing the resistance of the plasma column is $\sim 40\text{ohm/m}$. At $\sim 30\mu\text{s}$ the resistance is $\sim 20\text{ohm/m}$, and at $\sim 125\mu\text{s}$ the resistance is $\sim 100\text{ohm/m}$. Thereafter fluid turbulence within the plasma column begins to mix the hot discharge gas with cold outside air. The column, therefore, grows in radius as it becomes colder and denser, and its resistance grows exponentially.

A $180\mu\text{F}$ secondary bank, charged to 20kV, was used to sustain for up to 2ms two parallel 67cm long plasma discharges that made up the two halves of a folded monopole antenna in a study of the feasibility of using an atmospheric discharge plasma as an RF antenna.[5] This plasma antenna has been used to transmit and receive signals at 112MHz, the characteristic frequency of the antenna. While the plasma remained conducting, the signal transmitted from, and received on, the plasma antenna was within $\pm 1\text{db}$ of that transmitted from and received on a standard copper folded monopole antenna of the same size.

A $4\mu\text{F}$ secondary bank charged at up to 50kV was used to study the interaction between a REB and a discharge channel that had a current impressed on it in the same direction as the current in the REB.[4] The secondary discharge had a peak current of 50kA with a period of $\sim 20\mu\text{s}$. The 16kA, 40ns REB was injected both coaxially and at a 10° angle to the discharge axis. In both cases, the REB was captured by the magnetic field of the coflowing discharge current and transported the full length of the 1m long channel.

FUTURE WORK

To test the ability of long current carrying channels to transport high energy REBs we intend to extend the discharge channel length to $\sim 10\text{m}$, for this three major pieces of equipment need to be upgraded. The Nd:glass laser output will be increased to $\sim 250\text{J}$ in a 4ns pulse. We have already established that just such laser parameters are sufficient to produce

aerosol-initiated, air-breakdown over a distance in excess of 10m. The primary capacitor bank must supply a potential on the order of $\sim 100\text{kV}$ per meter of channel to track the laser channel. To that end, a $>1\text{MW}$ Marx generator is under construction. Finally, the switch which isolates the secondary bank from the primary discharge must be capable of holding off the 1Mv potential for the duration of the primary discharge, yet close on command at a low voltage.

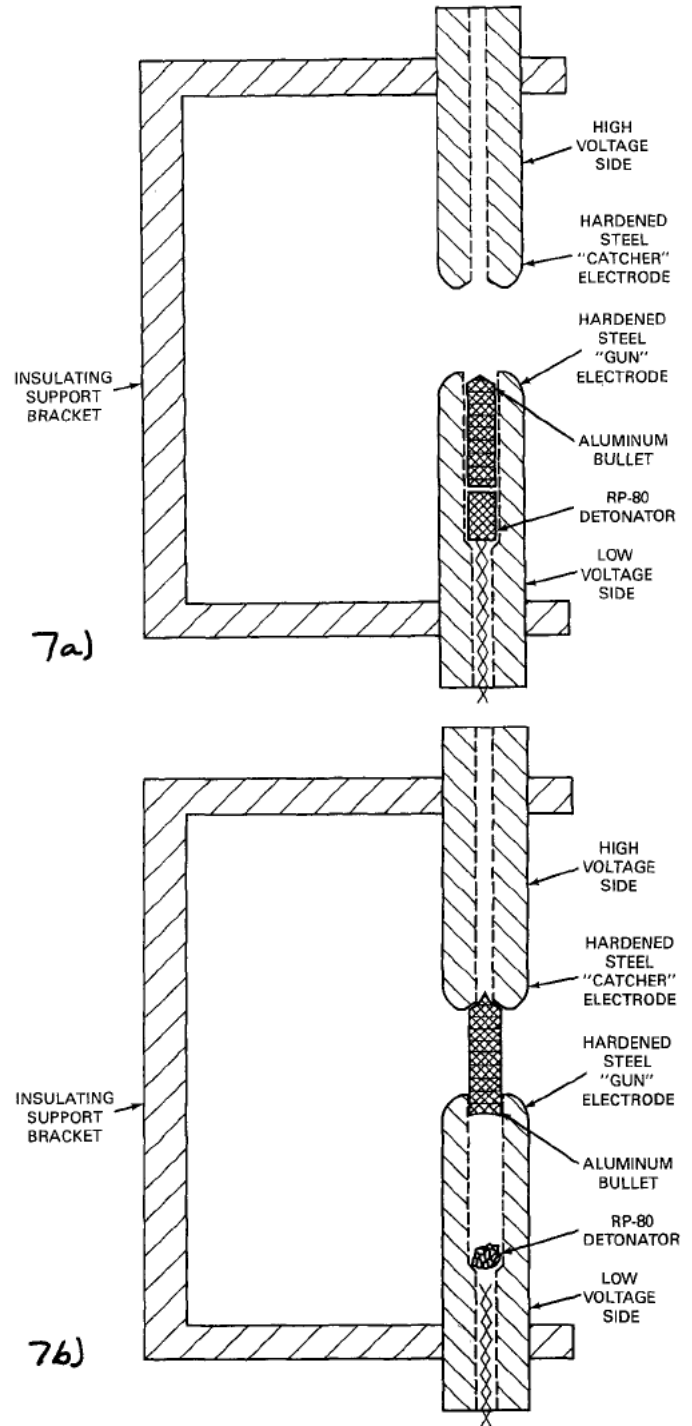

Figure 7. Schematic diagram of the explosively closed, oil dielectric test switch a) before closure and b) after closure.

We have measured the closure time as a function of electrode spacing for an explosively closed, oil dielectric switch. This switch has a solid aluminum bullet recessed inside the lower electrode sitting upon an RP-80 detonator. The bullet, which is longer than the oil gap spacing, is propelled across the gap and imbeds in the upper electrode while remaining connected to the lower electrode. See figure 7 for a pre- and post-closure views of the test stand. The gap closure delay time was $\sim 300\mu\text{s}$ for an oil gap of 5cm (see figure 8). The final switch configuration will have 5cm radius, hemispherical electrodes with removable, hardened steel inserts for the 'gun' and 'catcher'. A gap spacing of 5cm with transformer oil as the dielectric should provide adequate insulation for this application.

- [6] J.R. Greig, R.F. Fernsler, D.P. Murphy, R.E. Pechacek, J. Perrin, and M. Raleigh, "Laser Guided Electric Discharges in the Atmosphere", Proc. 7th Int. Conf. on Gas Discharges and Their Applications, London (1982), p464, {Peter Peregrinus Ltd., pub.}.
 [7] L.E. Salanave, Lightning and Its Spectrum, The University of Arizona Press, Tucson, Ar 1980, p49.
 [8] R.L. Gardner, M.H. Frese, J.L. Gilbert, and C.L. Longmire, "A Physical Model of Nuclear Lightning", Phys. Fluids, vol 27, p2694 (1984).
 [9] J.D. Colvin and C.K. Mitchell, private communication.

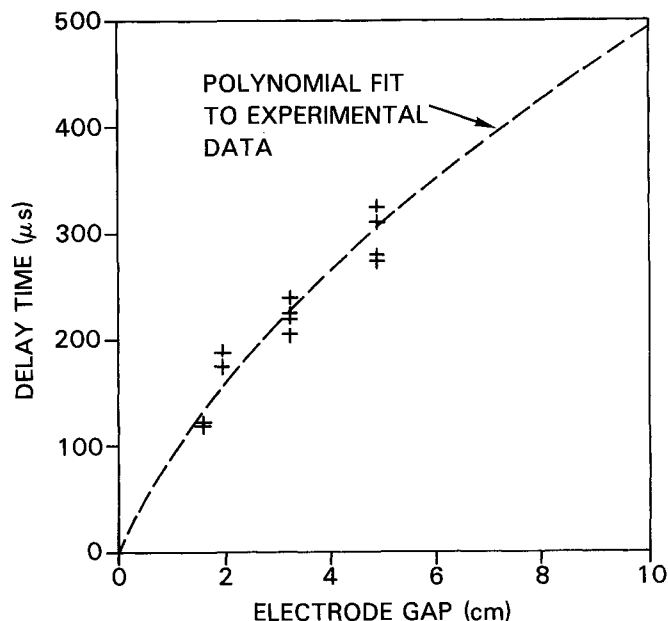

Figure 8. Plot of the delay time between trigger and closure versus electrode gap for the explosively closed, oil dielectric switch shown in figure 7.

REFERENCES

- [1] J.R. Greig, D.W. Koopman, R.F. Fernsler, R.E. Pechacek, I.M. Vitkovitsky, and A.W. Ali, "Electrical Discharges by Pulsed CO_2 -Laser Radiation", Phys. Rev. Lett., vol 41, p174 (1978).
 [2] J.R. Greig, R. Pechacek, M. Raleigh, I.M. Vitkovitsky, R. Fernsler, and J. Halle, "Interaction of Laser-Induced Ionization with Electric Fields", AIAA-80-1380.
 [3] J.R. Greig, R.E. Pechacek, and M. Raleigh, "Channel Cooling by Turbulent Convective Mixing", to be published Phys. Fluids, (1985).
 [4] D.P. Murphy, M. Raleigh, E. Laikin, J.R. Greig, and R.E. Pechacek, "Electron Beam Transport Through the Atmosphere in Reduced-Density, Current-Carrying Channels", Proc. 9th Int. Symp. on Engineering Prob. in Fus. Res., Chicago (1981), IEEE 81 CH 1715-2 NPS, Vol II, p1548.
 [5] T.J. Dwyer, J.R. Greig, D.P. Murphy, J.M. Perrin, R.E. Pechacek, and M. Raleigh, "On the Feasibility of Using an Atmospheric Discharge Plasma as an RF Antenna", IEEE Trans. on Antennas and Propagation, Vol AP-32, No. 2, p141 (1984).