

REFERENCE ONLY

TM No. 86-1203



NAVAL UNDERWATER SYSTEMS CENTER
NEW LONDON LABORATORY
NEW LONDON, CT 06320

Technical Memorandum

TURBULENT BOUNDARY LAYER WALL PRESSURE
FLUCTUATION REDUCTIONS USING WATER INJECTION

Date: 8 October 1986

Prepared by: Howard Schloemer
Dr. H. Schloemer
Submarine Sonar Department

Prepared by: E. Payne
E. Payne
Submarine Sonar Department

REFERENCE ONLY

Approved for Public Release; distribution unlimited.

Report Documentation Page

Form Approved
OMB No. 0704-0188

Public reporting burden for the collection of information is estimated to average 1 hour per response, including the time for reviewing instructions, searching existing data sources, gathering and maintaining the data needed, and completing and reviewing the collection of information. Send comments regarding this burden estimate or any other aspect of this collection of information, including suggestions for reducing this burden, to Washington Headquarters Services, Directorate for Information Operations and Reports, 1215 Jefferson Davis Highway, Suite 1204, Arlington VA 22202-4302. Respondents should be aware that notwithstanding any other provision of law, no person shall be subject to a penalty for failing to comply with a collection of information if it does not display a currently valid OMB control number.

1. REPORT DATE 08 OCT 1986		2. REPORT TYPE Technical Memo		3. DATES COVERED 08-10-1986 to 08-10-1986	
4. TITLE AND SUBTITLE Turbulent Boundary Layer Wall Pressure Fluctuation Using Water Injection				5a. CONTRACT NUMBER	
				5b. GRANT NUMBER	
				5c. PROGRAM ELEMENT NUMBER	
6. AUTHOR(S) Howard Schloemer; E. Payne				5d. PROJECT NUMBER A75600	
				5e. TASK NUMBER	
				5f. WORK UNIT NUMBER	
7. PERFORMING ORGANIZATION NAME(S) AND ADDRESS(ES) Naval Underwater Systems Center, New London, CT, 06320				8. PERFORMING ORGANIZATION REPORT NUMBER TM 861203	
9. SPONSORING/MONITORING AGENCY NAME(S) AND ADDRESS(ES) ONR				10. SPONSOR/MONITOR'S ACRONYM(S) ONR	
				11. SPONSOR/MONITOR'S REPORT NUMBER(S)	
12. DISTRIBUTION/AVAILABILITY STATEMENT Approved for public release; distribution unlimited					
13. SUPPLEMENTARY NOTES NUWC2015					
14. ABSTRACT This technical memorandum consists of the text and visual graphics of an invited paper to be presented in December 1986 at the Forum on Flow Induced Noise and Vibrations sponsored by the Noise Control and Acoustics division of the American Society of Mechanical Engineers (ASME). This paper is a status report of ongoing experiments in the Naval Underwater Systems Center (NUSC) acoustically quiet water tunnel located in New London, CT. The objective of these experiments is to determine the utility of cold (ambient) water injection into a boundary layer to reduce the intensity of turbulent boundary layer wall pressure fluctuations (TBLPF) or as it's commonly called flow noise. Future studies will characterize the effect of heated water injection on TBLPF. The current experiments consist of turbulent boundary layer wall pressure fluctuation measurements downstream of a perforated steel plate through which ambient temperature water is injected into the turbulent boundary layer.					
15. SUBJECT TERMS turbulent boundary layer; acoustically quiet water tunnel; turbulent boundary layer wall pressure fluctuations; TBLPF					
16. SECURITY CLASSIFICATION OF:			17. LIMITATION OF ABSTRACT	18. NUMBER OF PAGES	19a. NAME OF RESPONSIBLE PERSON
a. REPORT unclassified	b. ABSTRACT unclassified	c. THIS PAGE unclassified			

ABSTRACT

This technical memorandum consists of the text and visual graphics of an invited paper to be presented in December 1986 at the Forum on Flow Induced Noise and Vibrations sponsored by the Noise Control and Acoustics division of the American Society of Mechanical Engineers (ASME).

This paper is a status report of ongoing experiments in the Naval Underwater Systems Center (NUSC) acoustically quiet water tunnel located in New London, CT. The objective of these experiments is to determine the utility of cold (ambient) water injection into a boundary layer to reduce the intensity of turbulent boundary layer wall pressure fluctuations (TBLPF) or as it's commonly called flow noise. Future studies will characterize the effect of heated water injection on TBLPF. The current experiments consist of turbulent boundary layer wall pressure fluctuation measurements downstream of a perforated steel plate through which ambient temperature water is injected into the turbulent boundary layer.

ADMINISTRATIVE INFORMATION

This memorandum was prepared under NUSC Project No. A75600, "Hydrodynamic Flow Noise Reduction Via Hot Water Injection," Principal Investigator: Dr. Howard H. Schloemer (Code 2133). The sponsoring activity is the Office of the Chief of Naval Research, Code 26D (E. O. Richards).

The authors of this memorandum are located at the Naval Underwater Systems Center, New London Laboratory, Code 2133, New London, CT 06320.

BACKGROUND

The main objective of the experiments described in this report (Figure 1) is to determine the utility of cold (ambient) water injection into a boundary layer to reduce TBLPF. The test configuration is similar to that recently reported (1984) by Soviet investigators Lyamshev, et. al. in references (1) and (2). The major experimental parameters that were used in the N. N. Andreev Acoustics Institute (Moscow, USSR) water tunnel are shown in Figure 2. The Soviet water tunnel flow parameters are similar to those of NUSC's Acoustic Water Tunnel shown in Figure 3. The maximum flow rate in the NUSC water tunnel is approximately 2850 gpm which is equivalent to a maximum velocity of 18-ft/sec in the rectangular section. The maximum velocity of 50-ft/sec in the circular section is obtained with the same

pump operating with a higher pressure differential across it and consequently lower mass flow rate. The ball valves permit each section to be used independently. Extensive use of rubber hoses, large upstream and downstream plenum tanks, vibration isolation, and massive foundations make this pump driven water tunnel relatively quiet for TBLPF measurements. The heat exchanger maintains a constant water temperature to within $\pm 2^\circ\text{F}$.

The injection experiment was carried out in the rectangular section. Details are shown in Figure 4. The center plenum chamber contains an inlet diffuser, screens, honeycomb, and circular to rectangular outlet nozzle with a contraction ratio of 14.7 to 1 which provides a free stream longitudinal turbulence level of approximately 0.2 percent. The 4-inch height at the entrance to the rectangular test section is adjustable to provide a zero pressure gradient flow along the full 94-inch length. Six 10-inch diameter instrumentation ports provide access along the top 12-inch width of the tunnel. The height of the NUSC tunnel, 4-inch (101.6mm) is slightly less than the Soviet tunnel (120mm) with the latter having a better aspect ratio for two dimensional flow (width of 1000mm vs 12-inches (304.8mm)) than the NUSC tunnel. Distance downstream to the measurement section for the Soviet tunnel was 1000mm while most measurements in the NUSC tunnel were made at 1227mm downstream. Further details of the NUSC tunnel can be found in reference (3).

The comparison of nondimensional TBLPF based on turbulent boundary layer variables was made at 18-ft/sec (Figure 5) for both tunnels using the data from references (1) and (3). These compared quite well. δ^* is the boundary layer displacement thickness, U_∞ is the free stream velocity, f is the frequency in Hz, ρ is the fluid density, and $\phi(f)$ is the power spectral density of the wall pressure fluctuations.

In establishing the injection configuration for the NUSC tunnel, the Soviet experiment was used for guidance. The injection surface plate is shown in Figure 6a. The injected flow is normal to the plane of the paper in the direction toward the reader. Injection surface dimensions of 4.3-inches streamwise and 7.9-inches perpendicular to the flow are exactly those used by Lyamshev, et. al. The two circular plugs contain holes so that hydrophones can be located upstream and downstream of the injection region. The injection surface area is a perforated steel plate with holes 0.033" in diameter on .055" staggered centers with a 27.7 percent open area. This approximated the Soviet perforated plate.

The flush mounted hydrophones used were Gould CH-4C-50 hydrophones with a nominal receiving sensitivity of $-220 \text{ dB}/1\text{V}/\mu\text{Pa}$ and a sensitive face diameter of 0.096-inches. A straightforward data acquisition and analysis system was used as shown in the schematic in Figure 6b. The major problem encountered with the sensors was due to their low capacitance, 160pF, which results in high ambient electronic noise levels.

The injection test facility is shown in Figure 7 where the injection water supply is a fire hydrant (municipal water supply). It was designed to allow a controlled amount of water to be injected into the top of the tunnel, thus a particular injection rate could be established easily. The

downstream tunnel drain, located in the large downstream plenum chamber permitted steady flow operation with water injection. In the future the water from the injection water supply will be heated in the injection facility and injected in the tunnel so that its effects on the TBLPF can be measured.

TEST RESULTS

Shown in Figure 8 is a replot of the data obtained by Lyamshev, et. al. for three injection rates through a 150μ porous material at a distance of 1-inch downstream from the aft edge of the injection surface. Only the data where the vibration noise level was at least 10 dB lower than that of the TBLPF were reported in reference (1). Note the dramatic decrease in spectral density at a normal injection velocity (V_n) of only 2.7 percent that of free stream ($U_\infty = 10$ -ft/sec). At 500 Hz this decrease is approximately 19 dB. For lower injection rates there was little change except that the low frequency levels increased above the zero injection case. Lyamshev, et. al. stated that equivalent noise reductions observed at $V_n/U_\infty = .027$ through the porous material were obtained with a larger injection rate $V_n/U_\infty = 0.04$ through a perforated material described as .8mm holes spaced 3mm apart with rows shifted 1mm relative to another.

At 10-ft/sec the NUSC data is similar to the Soviet's. Spectral densities taken 0.6-inches downstream of the aft edge of the injection surface are displayed in Figure 9. Note that the decrease in level at an injection rate $V_n/U_\infty = 0.027$ is dramatic except below 80 Hz. At 500 Hz the decrease in spectral level is 27 dB which is greater than the 19 dB reported in reference (1). This difference may be due to this sensor being closer to the injection region and differences in boundary layer thickness and injectant surface details. The low injection rates, $V_n/U_\infty = .0055$ and $.0108$, have the same general characteristics as those of reference (1). At an injection rate of $V_n/U_\infty = .0420$, the maximum obtainable in NUSC's injection facility, a slight increase in TBLPF level over the $V_n/U_\infty = .0270$ condition. This may indicate that there exists some optimum injection rate where TBLPF reductions are a maximum.

"Spikes" (narrow bands of energy) seen in the data (Figure 10) are assumed to be electronic noise components. This is assumed because they occur at 60 Hz and multiples thereof. With the water tunnel shut down, a spectrum was taken which should represent sensor/electronic noise only. Another measure of ambient noise is obtainable when water is pumped through the circular section at the same pump speed that would produce 10-ft/sec in the rectangular section. The downstream ball valve in the rectangular section is shut to produce zero flow velocity in the test section. This data is shown in Figure 11. Compared with Figure 10, the electronic noise

spikes have increased in level and the general background level has hardly changed except at very low frequencies. Only injection data which is sufficiently above ambient levels are reported on.

The spectral density characteristics for a location 0.8-inches downstream from the aft edge of the injection surface are shown in Figure 12. The data show the same general behavior with increasing injection rates as it did with the sensor closer to the injection surface. For this case the decrease in spectral density at 500 Hz is approximately 26 dB. The hydrophone at a location 1.0-inches downstream (equivalent the location used in reference (1)) was not working properly during this set of experiments.

At a location 2.2-inches downstream, Figure 13 shows the same general trend for TBLPF reductions with various injection rates. The decrease in spectral density for $V_n/U_\infty = 0.027$ at 500 Hz is 19 dB. Here the two lowest and the two highest injection rates appear to represent two separate regimes indicating that there may exist some critical injection rate at which a substantial TBLPF reduction occurs.

Due to the tunnel construction with 10-inch diameter access ports spaced every 13.625-inches apart, it was not possible to spatially measure the recovery characteristics of the perturbed boundary layer at all desired locations aft of injection. At a downstream distance of 11.48-inches the wall pressure level has nearly recovered throughout most of the frequency range as determined from TBLPF measurements shown in Figure 14. Spectral levels below 200 Hz are still considerably higher than unperturbed values. At 500 Hz, a difference of 3 dB exists for both injection rates.

At the furthest downstream distance of 25.7-inches from the aft edge of the injection surface the difference between spectral densities at various injection rates is slight. This is shown in Figure 15. At low frequencies the spectra are very nearly identical but the perturbed flow pressure spectra are still 3 dB lower than non-perturbed value at 500 Hz. Thus, the effects of the injected fluid are still measurable at a downstream distance of 2-feet (or better than 25 unperturbed boundary layer thicknesses). There is no apparent increase in pressure spectral level due to the injectant fluid except at low frequencies.

AT 0.6-inches downstream of the aft edge of the injection zone (Figure 16), the same general effects as observed at 10-ft/sec are evident at a free stream velocity of 18-ft/sec. At 18-ft/sec the maximum injection rate obtainable with the current injection system is $V_n/U_\infty = 0.0189$. It is uncertain whether higher rates would have produced lower TBLPF levels. There is an increase in energy below 100 Hz and above 800 Hz for the highest injection rate. Ambient tunnel noise contamination may be affecting this data. The TBLPF level reductions at 500 and 1000 Hz are approximately 24 dB at each frequency. This compares to 26 dB at 500 Hz and 16 dB at 1000 Hz for the 10-ft/sec case at the same location (Figure 9). In comparing the shape of the spectra it is apparent that at the higher speed the decrease in TBLPF due to injection is greatest at higher

frequencies. It has not been determined whether this is due to the slightly thinner boundary layer at higher speeds or due to an injectant and free stream fluid interaction. This apparent frequency shift is more evident at the 2.2-inch downstream location for $U_\infty = 18$ -ft/sec as shown in Figure 17. The TBLPF reduction at 500 Hz is 16 dB and at 1000 Hz it's 22 dB. This compares with the corresponding location at 10-ft/sec (Figure 13) with a reduction of 22 dB at 500 Hz and 12 dB at 1000 Hz. Again, the major TBLPF reduction due to injection is clearly happening at higher frequencies for the 18-ft/sec maximum tunnel speed condition.

The general effect of injection is to lower the wall shear stress (τ_w) downstream of the injection surface which has been demonstrated by many investigators. For zero pressure gradient flows the wall pressure fluctuations are proportional to the cube of the friction velocity ($\sqrt{\tau_w/\rho}$) as deduced by Chase (reference (4)). Therefore, a reduction in wall shear stress will reduce TBLPF levels. There is evidence of this in experiments conducted in the separated region just aft of a backward facing step, as reported by Farabee and Casarella (reference (5)).

Measurements of the velocity profiles in the vicinity of the injection are not complete at this time and will be reported on at a later date. In lieu of velocity measurements a calculation was made by Keith (reference (6)) to estimate the injection rate which would cause separation (defined as wall shear stress equal to zero). The calculation indicated that an injection rate of approximately .015 or greater would cause separation downstream of the injection region. This would delineate two broad categories of perturbed boundary layer flow, those below .015 as nonseparated and above .015 as separated. The pressure spectrum data obtained at 10-ft/sec support this distinction. The major reductions in TBLPF occur at injection rates of .027 and .042 with separated flows whereas at injection rates of .0055 and .0108 presumably nonseparated conditions exist.

Another indication of separation is obtained from Figures 18(a - d) which is the phase between two hydrophones at 0.6 and 0.8-inches downstream (separation 0.2-inches) at various injection rates ($U_\infty = 10$ -ft/sec). From this data the speed of the convected eddies may be determined. For zero injection the phase velocity (U_p) is 6.5-ft/sec or a ratio, $U_p/U_\infty = .65$ measurable up to a frequency of approximately 440 Hz. These measurements were made in 7.5 Hz effective bandwidths and may be interpreted as phase convection velocities as described by Blake (reference (7)). The results agree qualitatively with recent measurements by Farabee (reference (8)) for the equilibrium (zero pressure gradient) boundary layer. As the injection rate is increased, shown in Figures 18b through 18d, the high frequency phase becomes unstable. This is due to the injectant fluid perturbing the inner layer of the boundary layer close to the wall while having a smaller effect on the outer portion. As the injection rate increases this continues until a phase velocity approximately equal to zero is reached. This indicates separation or at least a zone of quiescent fluid where the pressure fluctuations are not convected downstream. The injection rate at

separation, $V_n/U_\infty = .027$, (Figure 18d) agrees with the calculation of Keith (reference (6)) for separation to occur at injection rates of .015 or greater.

The onset of separation will be clarified in later experiments by measuring the velocity profile in this region.

CONCLUSION

This limited set of measurements show that small rates of water at ambient temperature injected into an established turbulent boundary layer (of the same fluid) will produce a dramatic decrease in turbulent boundary layer wall pressure fluctuations intensity. The largest reductions occur at mid-frequencies just aft of the injection region and reductions persist at least 25 boundary layer thicknesses downstream. There is no apparent increase in TBLPF pressure spectra due to the injectant except at low frequencies. None of the large increases in pressure intensity normally observed in TBLPF pressure spectra after reattachment (downstream of steps or fences) are observed in the return to unperturbed conditions with injection. It appears that separation just aft of the injection region may cause the large reduction measured in the TBLPF pressure spectra in the mid frequency band.

LIST OF FIGURES

1. Objective
2. Background
3. Naval Underwater Systems Center Acoustic Water Tunnel
4. Rectangular Test Section Assembly
5. Nondimensional Spectral Density Comparison at 18-ft/sec
- 6a. Naval Underwater Systems Center Injection Plate Configuration
- 6b. Data Acquisition System Schematic
7. Naval Underwater Systems Center Water Tunnel Injection Facility
8. Soviet Experimental Water Tunnel Data
9. Pressure Spectral Density at Various Injection Rates
Position: 0.6-inches downstream, $U_{\infty} = 10\text{-ft/sec}$
10. Pressure Spectral Density at Zero Tunnel Speed
11. Pressure Spectral Density at 10-ft/sec Equivalent Tunnel Speed.
12. Pressure Spectral Density at Various Injection Rates
Position: 0.8-inches downstream, $U_{\infty} = 10\text{-ft/sec}$
13. Pressure Spectral Density at Various Injection Rates
Position: 2.2-inches downstream, $U_{\infty} = 10\text{-ft/sec}$
14. Pressure Spectral Density at Various Injection Rates
Position: 11.48-inches downstream, $U_{\infty} = 10\text{-ft/sec}$
15. Pressure Spectral Density at Various Injection Rates
Position: 25.7-inches downstream, $U_{\infty} = 10\text{-ft/sec}$
16. Pressure Spectral Density at Various Injection Rates
Position: 0.6-inches downstream, $U_{\infty} = 18\text{-ft/sec}$
17. Pressure Spectral Density at Various Injection Rates
Position: 2.2-inches downstream, $U_{\infty} = 18\text{-ft/sec}$
- 18a. - 18d. Phase Velocity Transfer Function at Various Injection Rates
Position: 0.6 and 0.8-inches downstream, $U_{\infty} = 10\text{-ft/sec}$



OBJECTIVE

- **DETERMINE THE UTILITY OF WATER INJECTION FOR FLOW NOISE REDUCTION**
 - **CHARACTERIZE THE EFFECT OF COLD AND HOT WATER INJECTION ON THE TURBULENT BOUNDARY LAYER PRESSURE FLUCTUATIONS**

Figure 1



BACKGROUND

SOVIET WATER TUNNEL EXPERIMENT

- **REDUCTION IN WALL PRESSURE FLUCTUATIONS WITH COLD WATER INJECTION**
- **EXPERIMENTAL PARAMETERS**
 - **INJECTION RATE, $\frac{V_n}{U_\infty}$: 0-.042**
 - **INJECTION AREA: 34 in²**
 - **SENSOR LOCATION: 1.0 in. FROM DOWNSTREAM EDGE OF INJECTION REGION**
 - **TUNNEL FLOW: 10 - 18 ft./sec.**
 - **INJECTION SURFACES: — .031 in. DIAMETER PERFORATED MATERIAL**
 - **150 μ m POROUS MATERIAL**

Figure 2

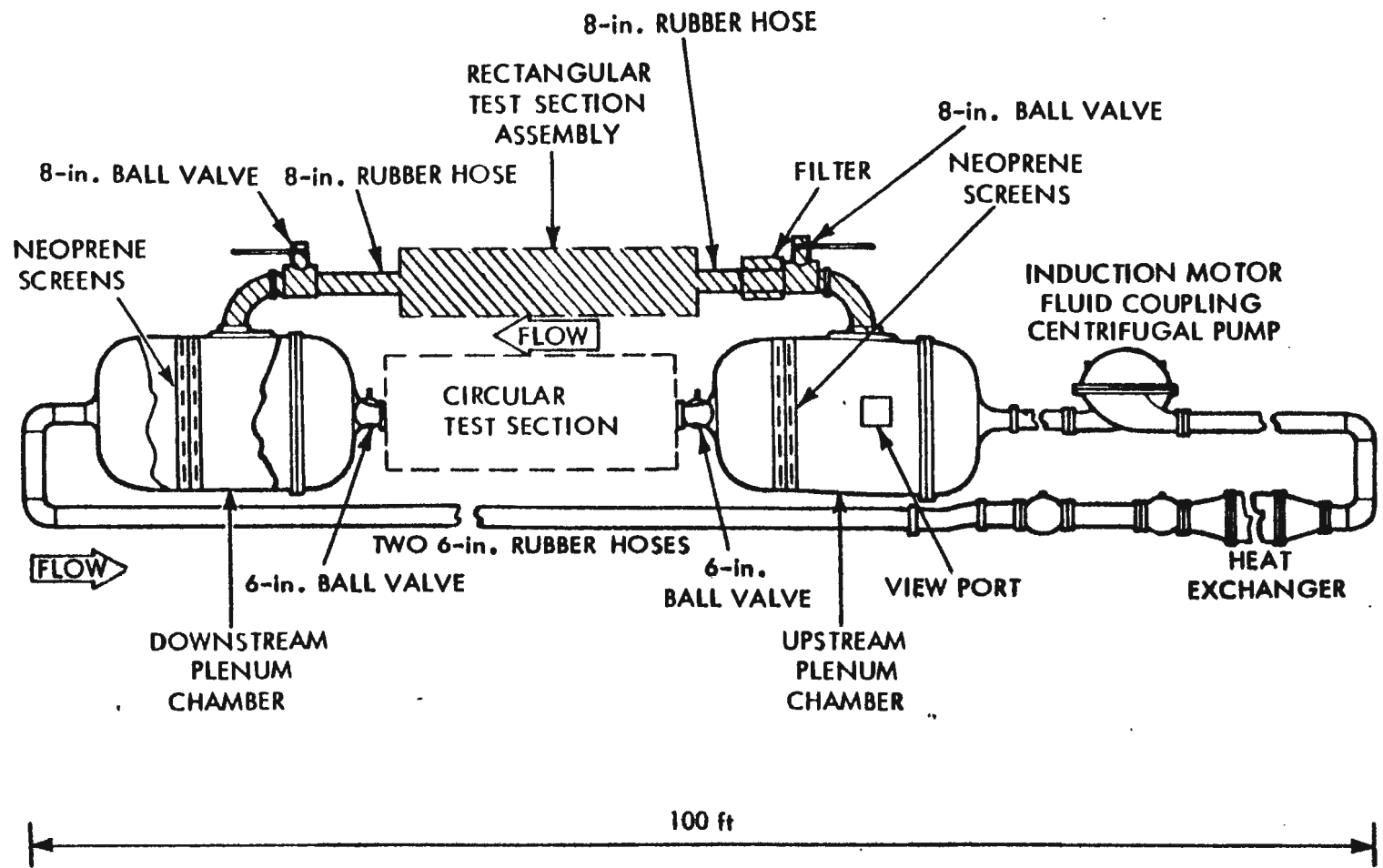

Figure 3 NUSC ACOUSTIC WATER TUNNEL

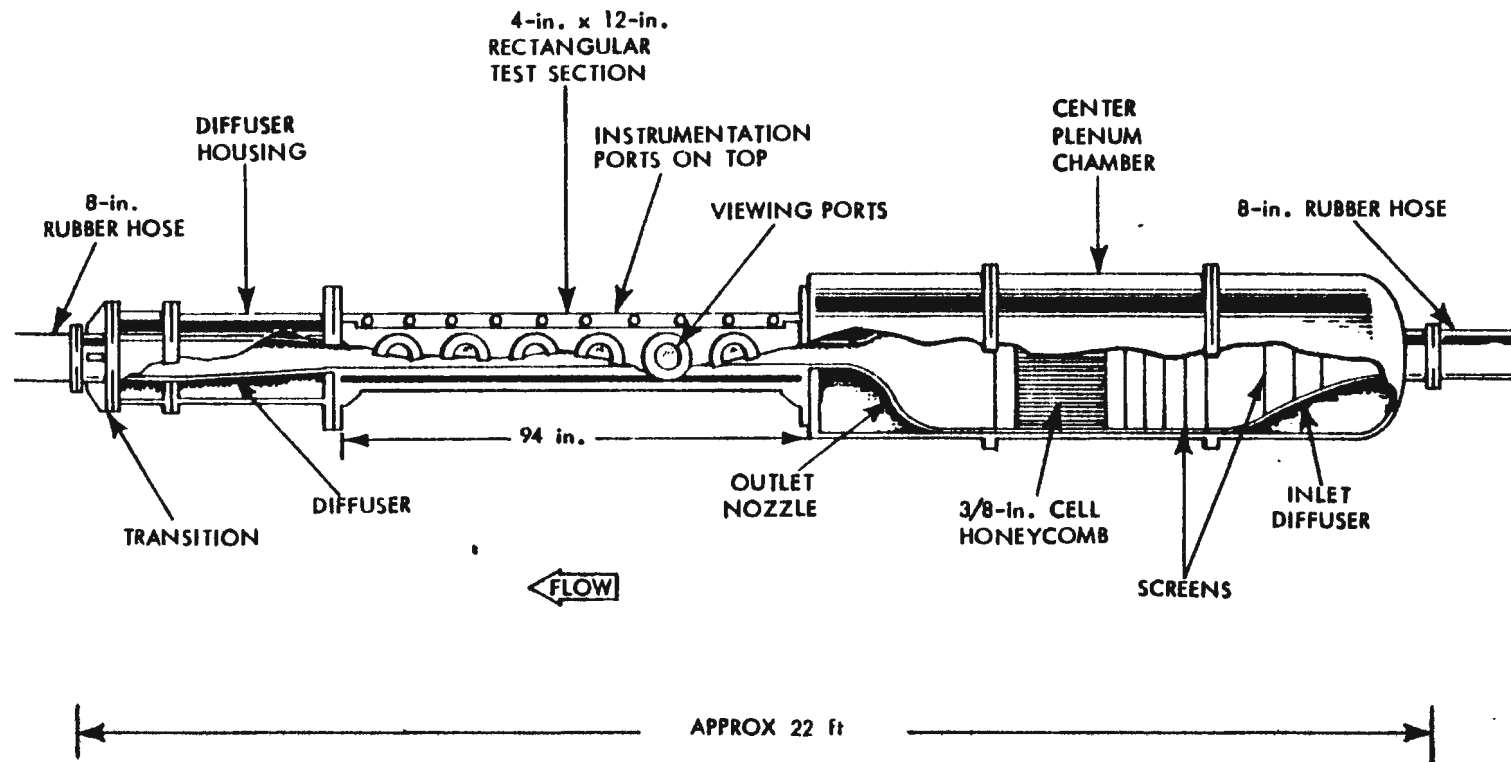

Figure 4 RECTANGULAR TEST SECTION ASSEMBLY

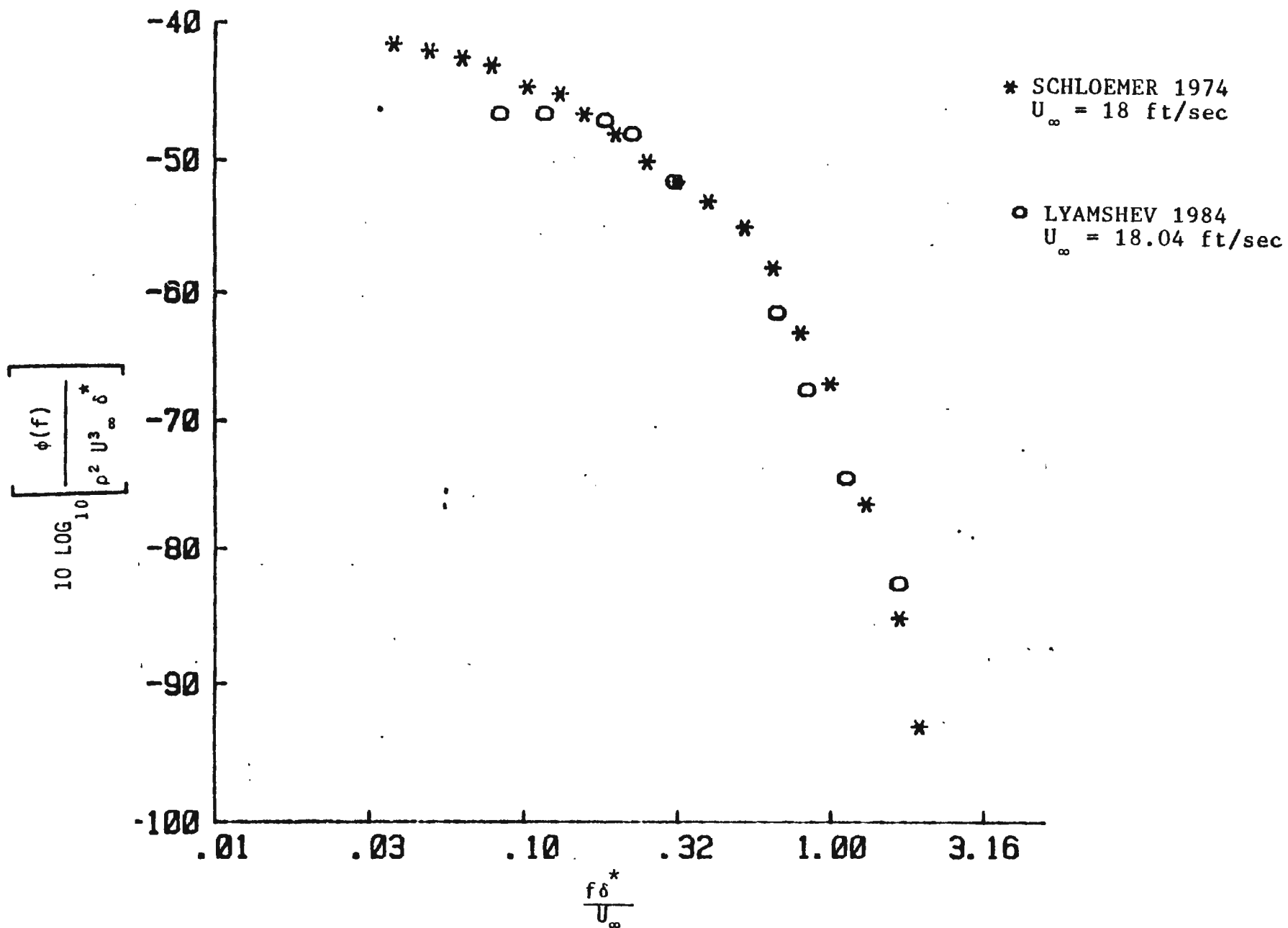

Figure 5 NONDIMENSIONAL SPECTRAL DENSITY



NUSC INJECTION PLATE CONFIGURATION

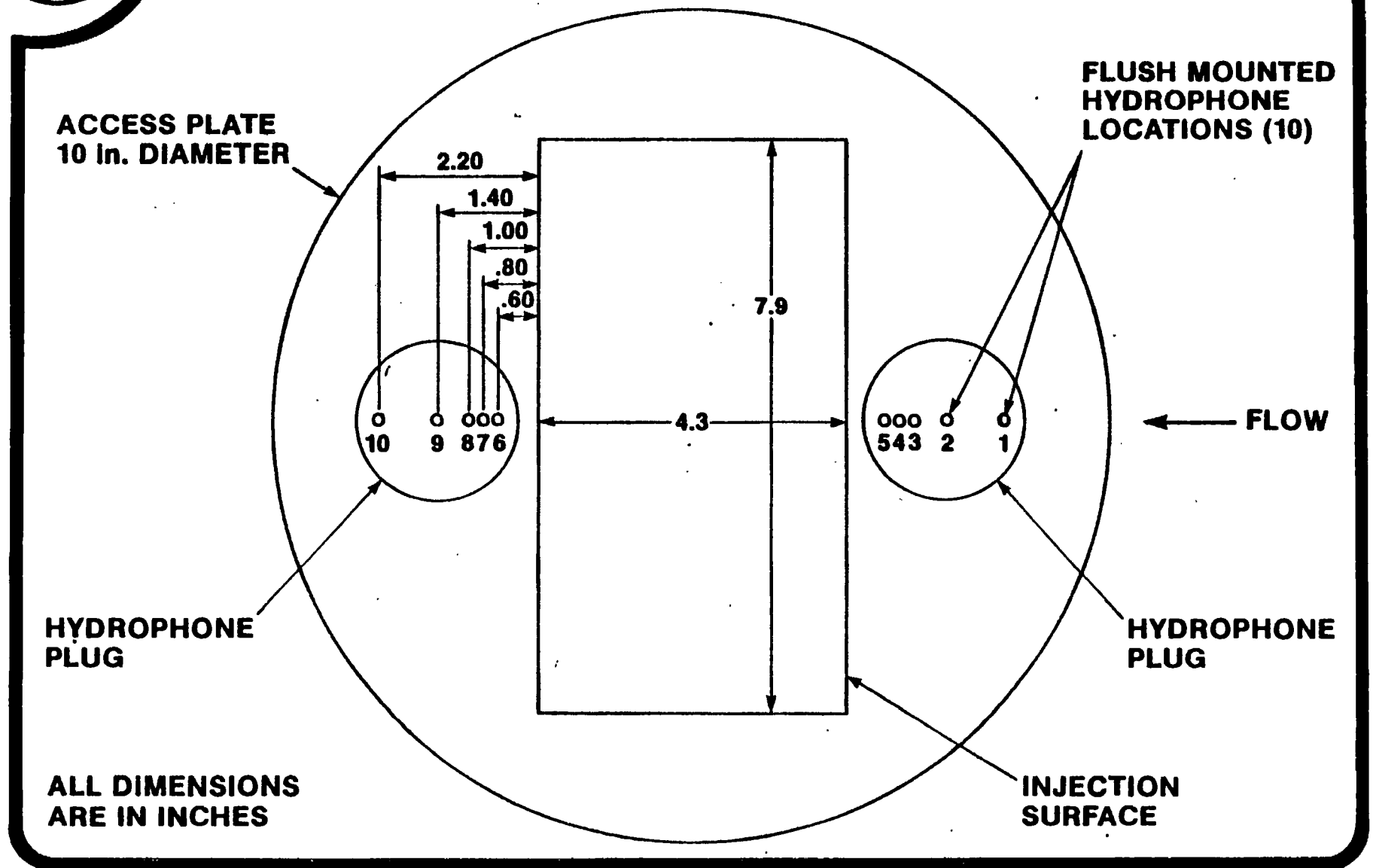
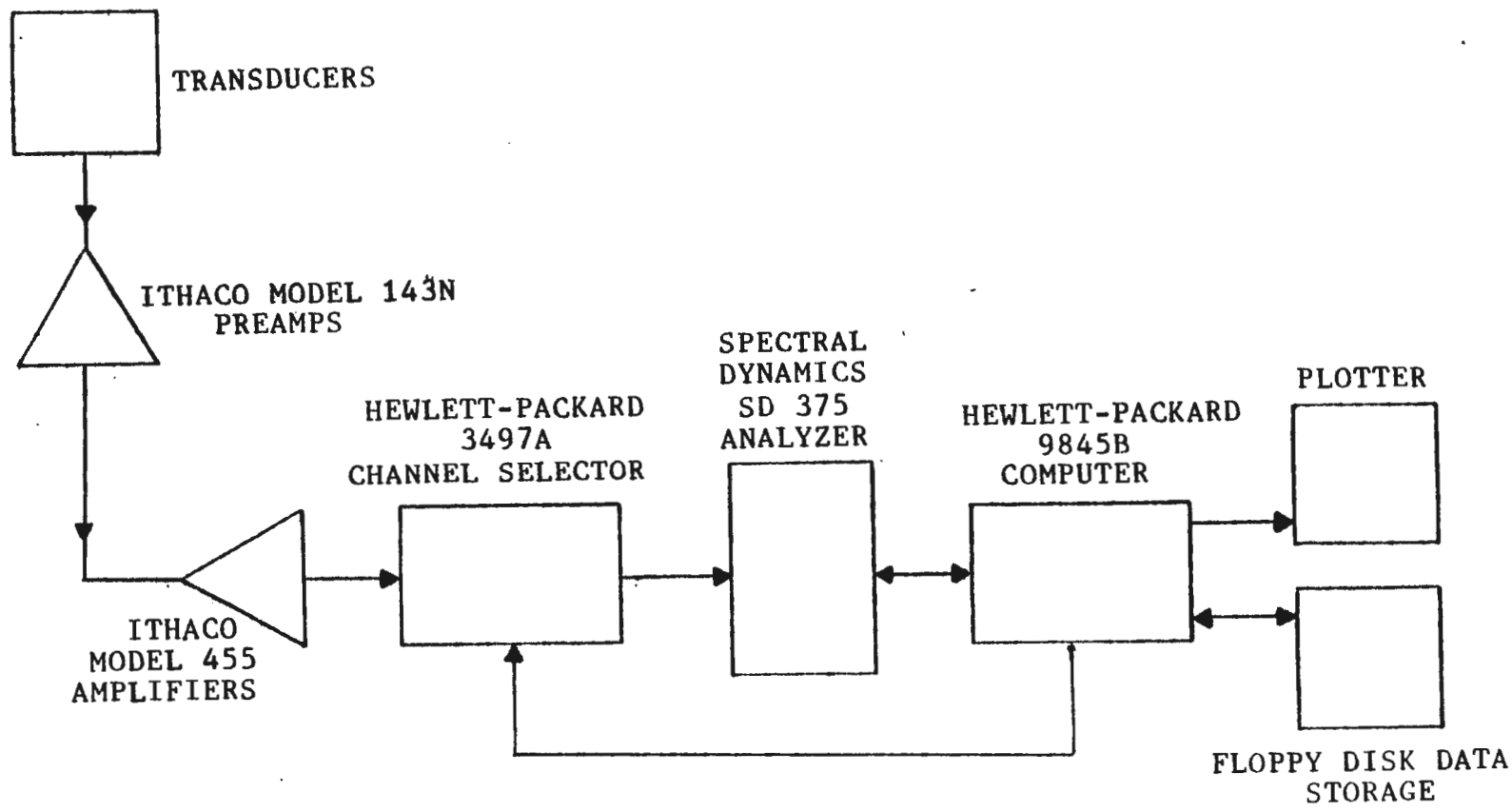

Figure 6a



14

Figure 6b DATA ACQUISITION SYSTEM SCHEMATIC



NUSC WATER TUNNEL INJECTION TEST FACILITY

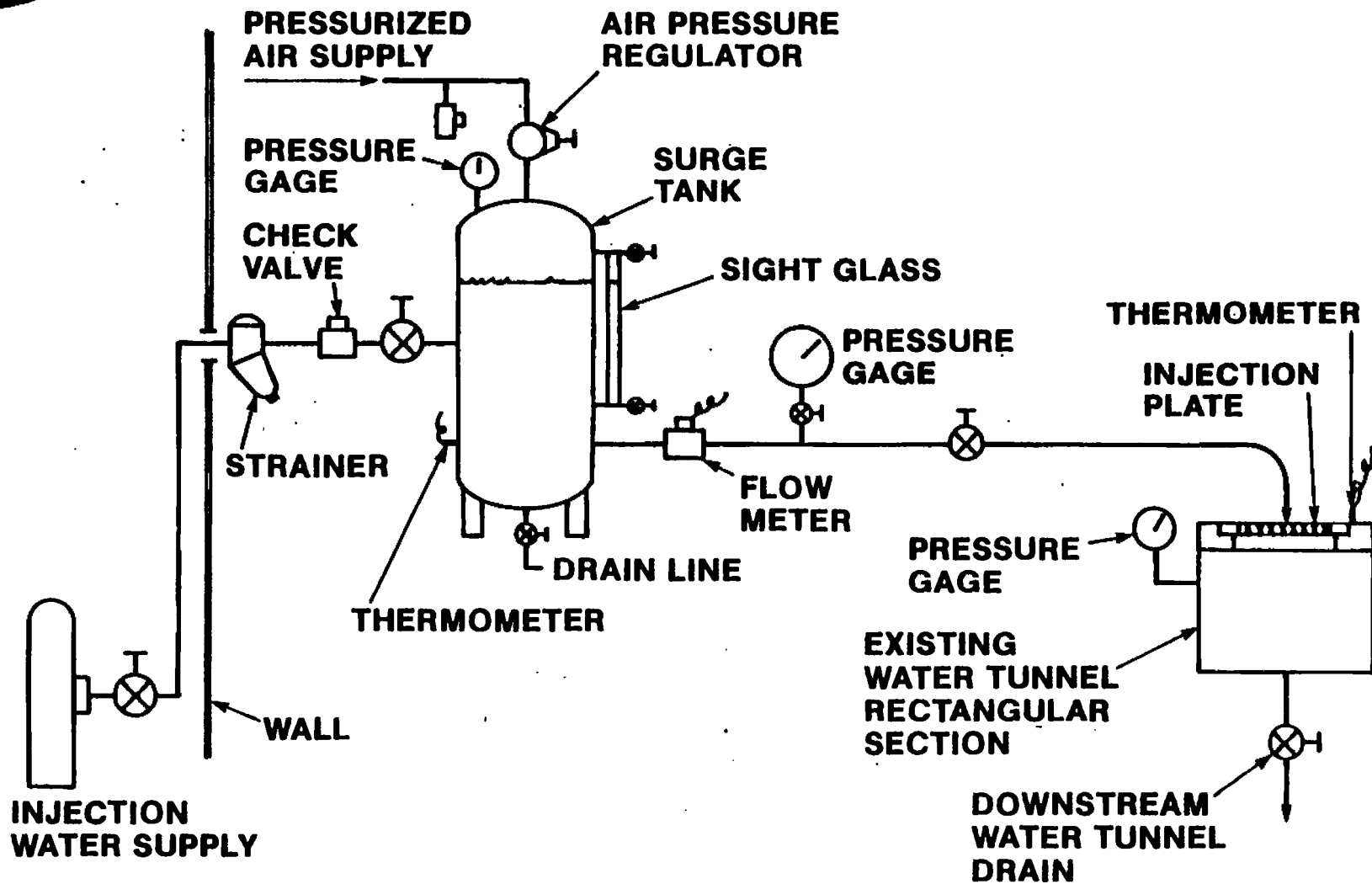
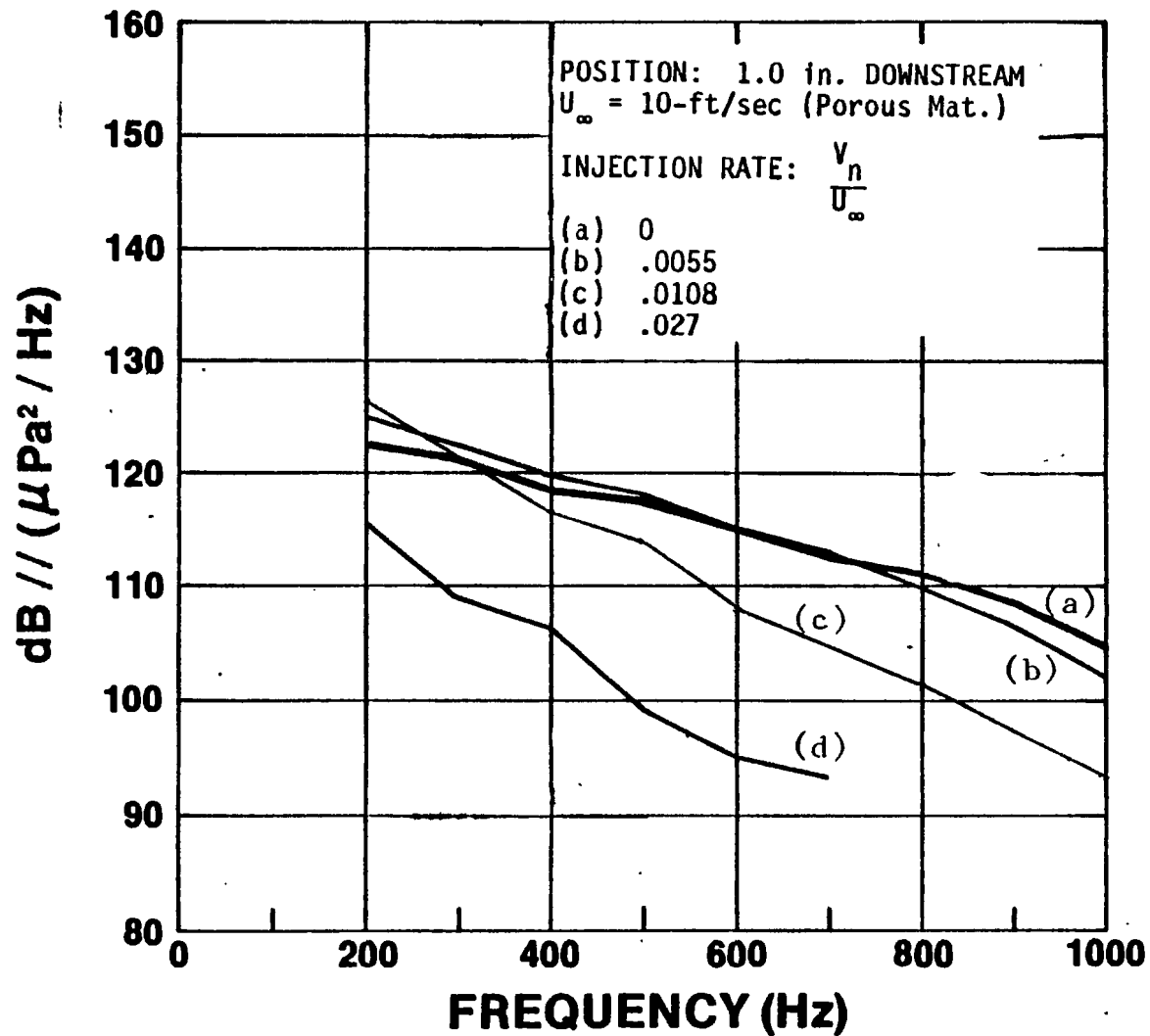

Figure 7



SOVIET EXPERIMENTAL WATER TUNNEL DATA



REFERENCE: L.M. LYAMSHEV, et. al. SOVIET PHYS. ACOUST., 1984

Figure 8

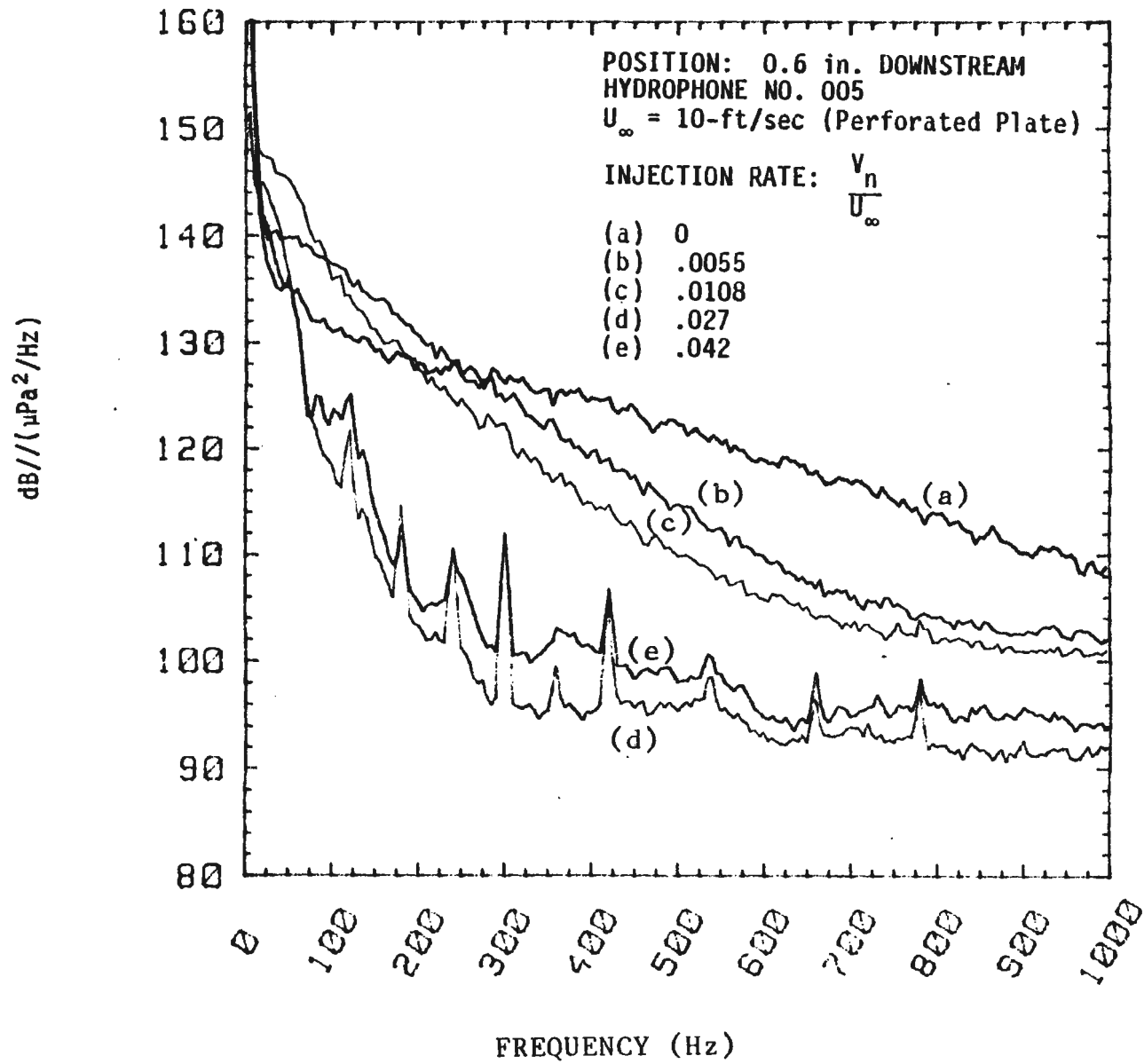

Figure 9 PRESSURE SPECTRAL DENSITY AT VARIOUS INJECTION RATES

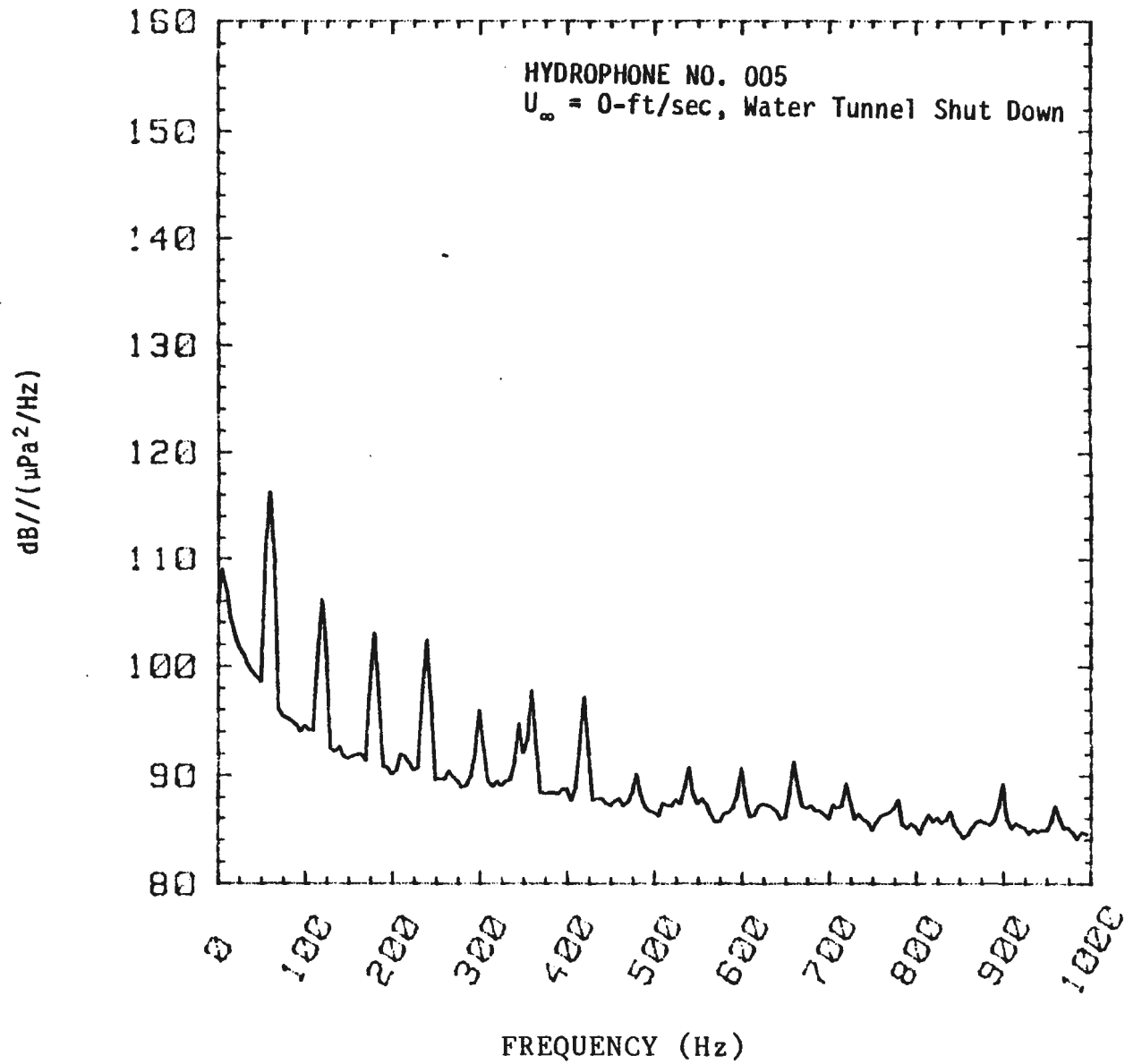

Figure 10 PRESSURE SPECTRAL DENSITY AT ZERO TUNNEL SPEED

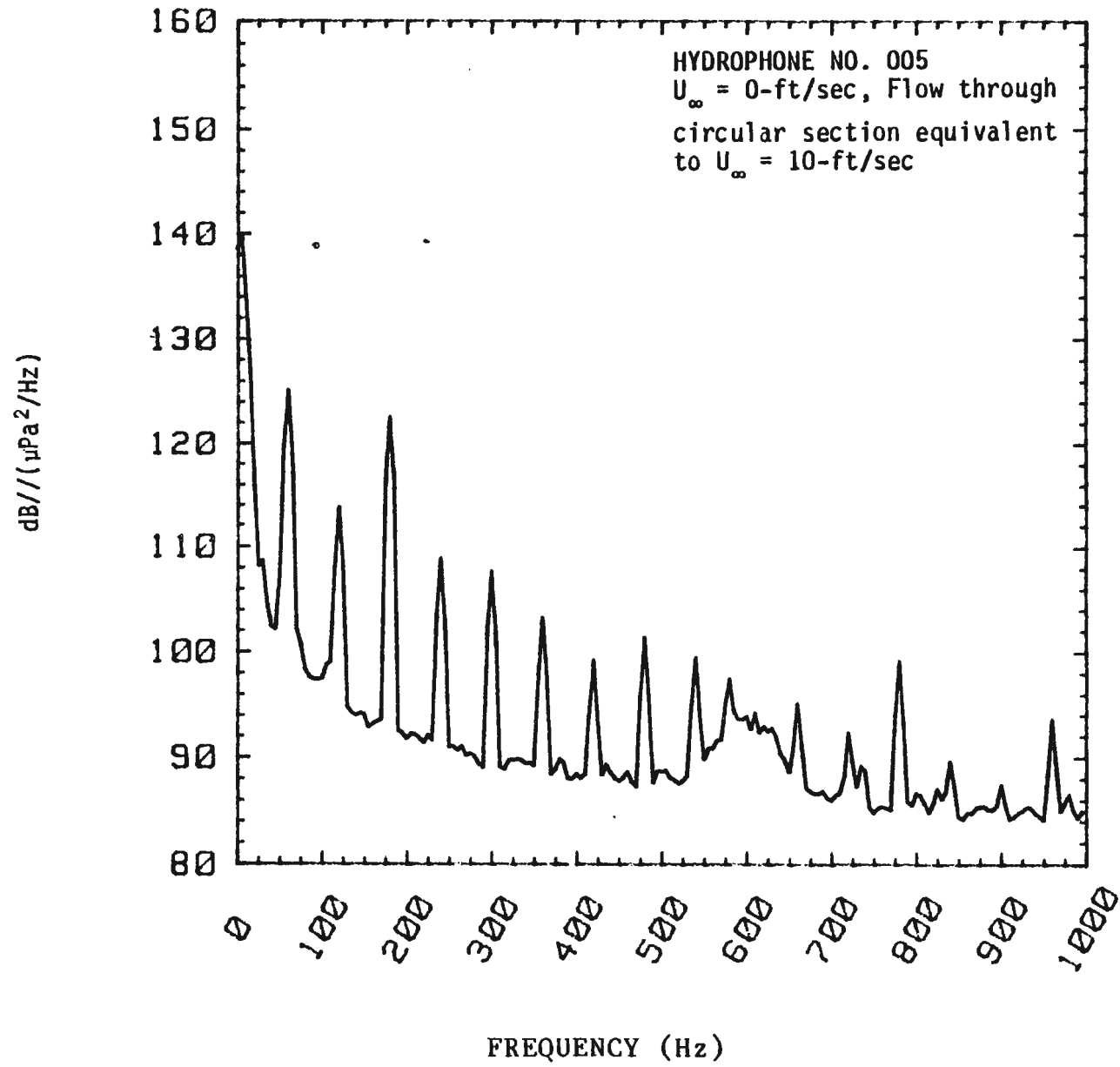

Figure 11 PRESSURE SPECTRAL DENSITY AT 10-FT/SEC EQUIVALENT TUNNEL SPEED

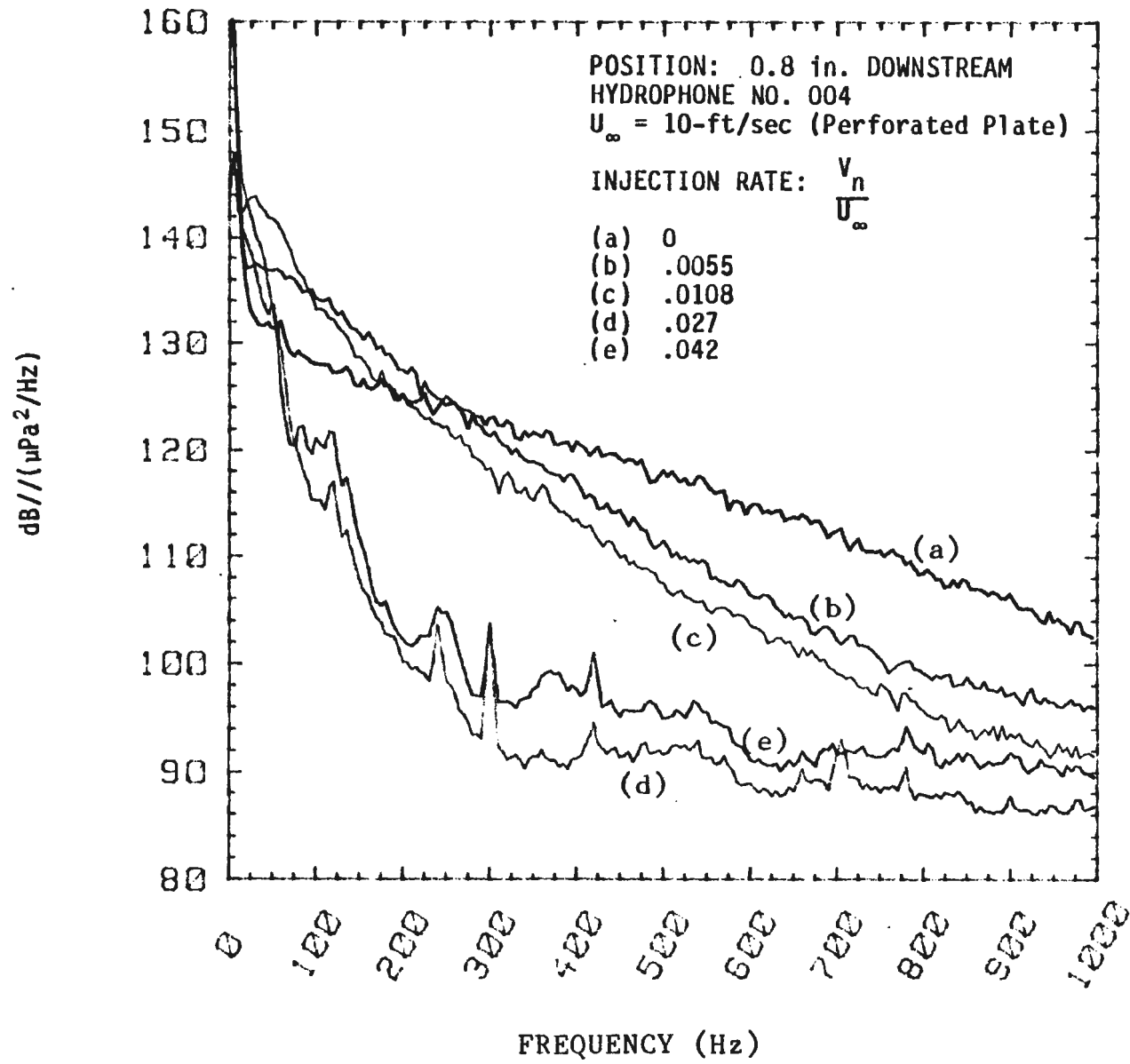

Figure 12 PRESSURE SPECTRAL DENSITY AT VARIOUS INJECTION RATES

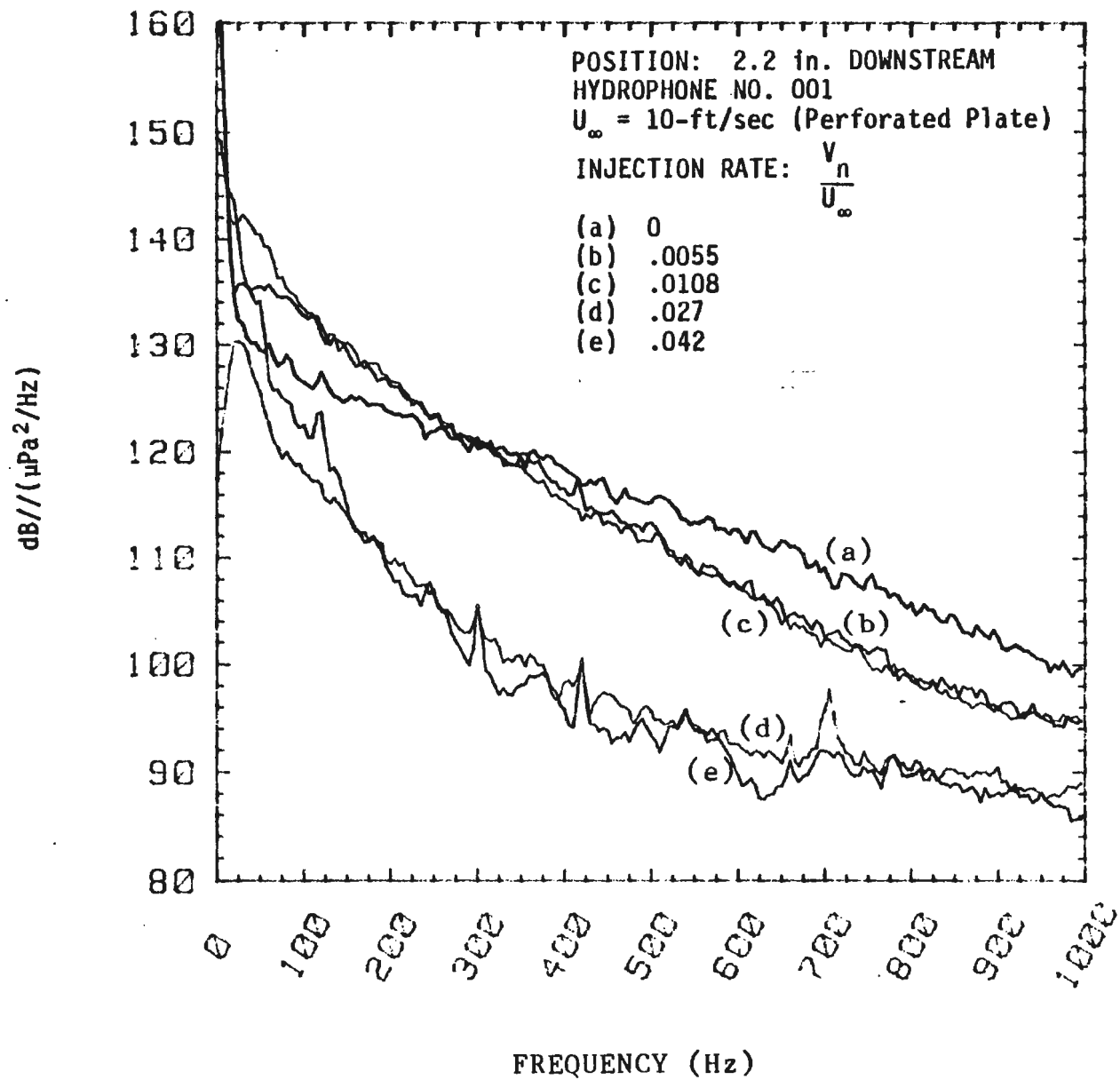

Figure 13 PRESSURE SPECTRAL DENSITY AT VARIOUS INJECTION RATES

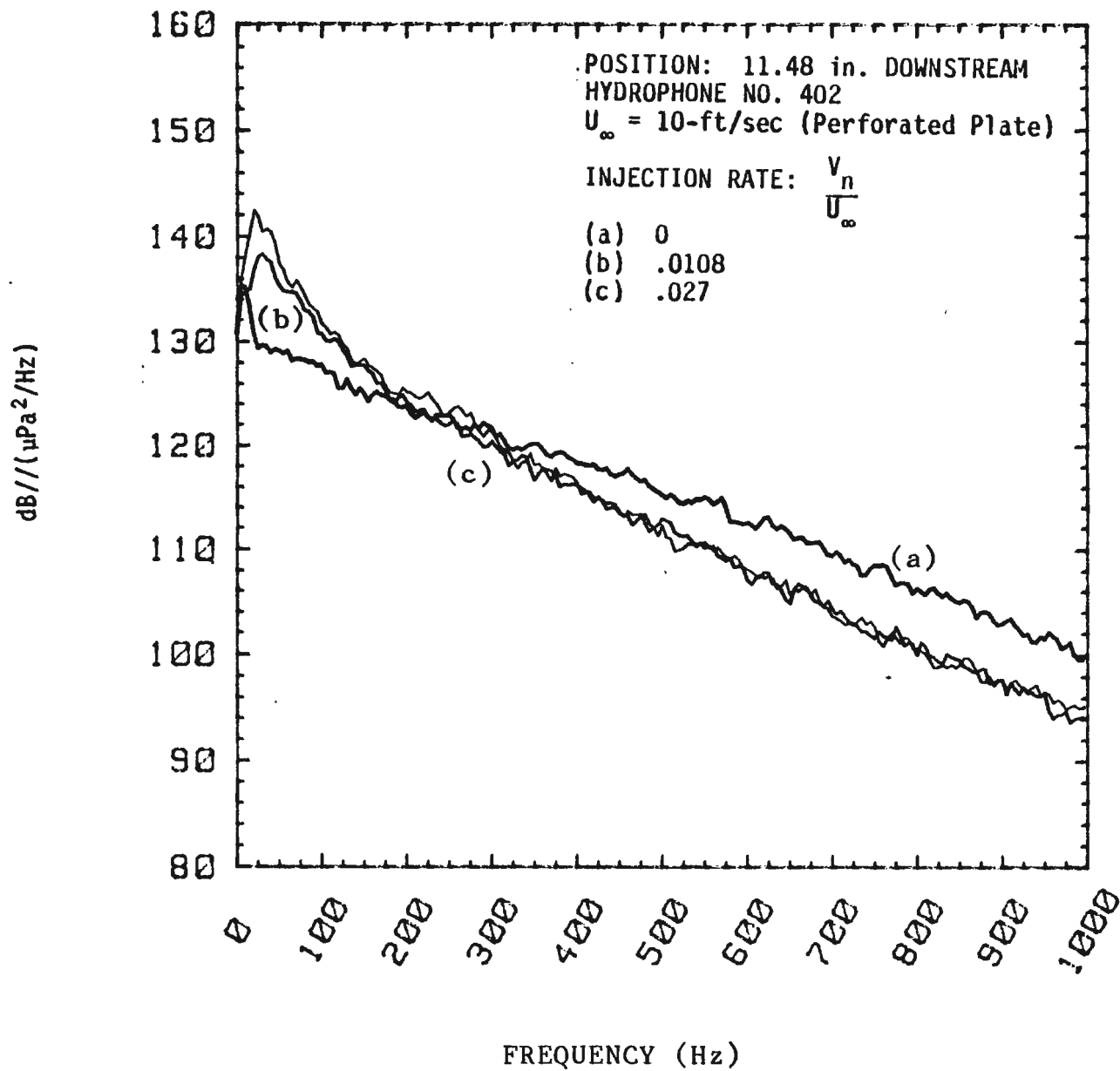

Figure 14 PRESSURE SPECTRAL DENSITY AT VARIOUS INJECTION RATES

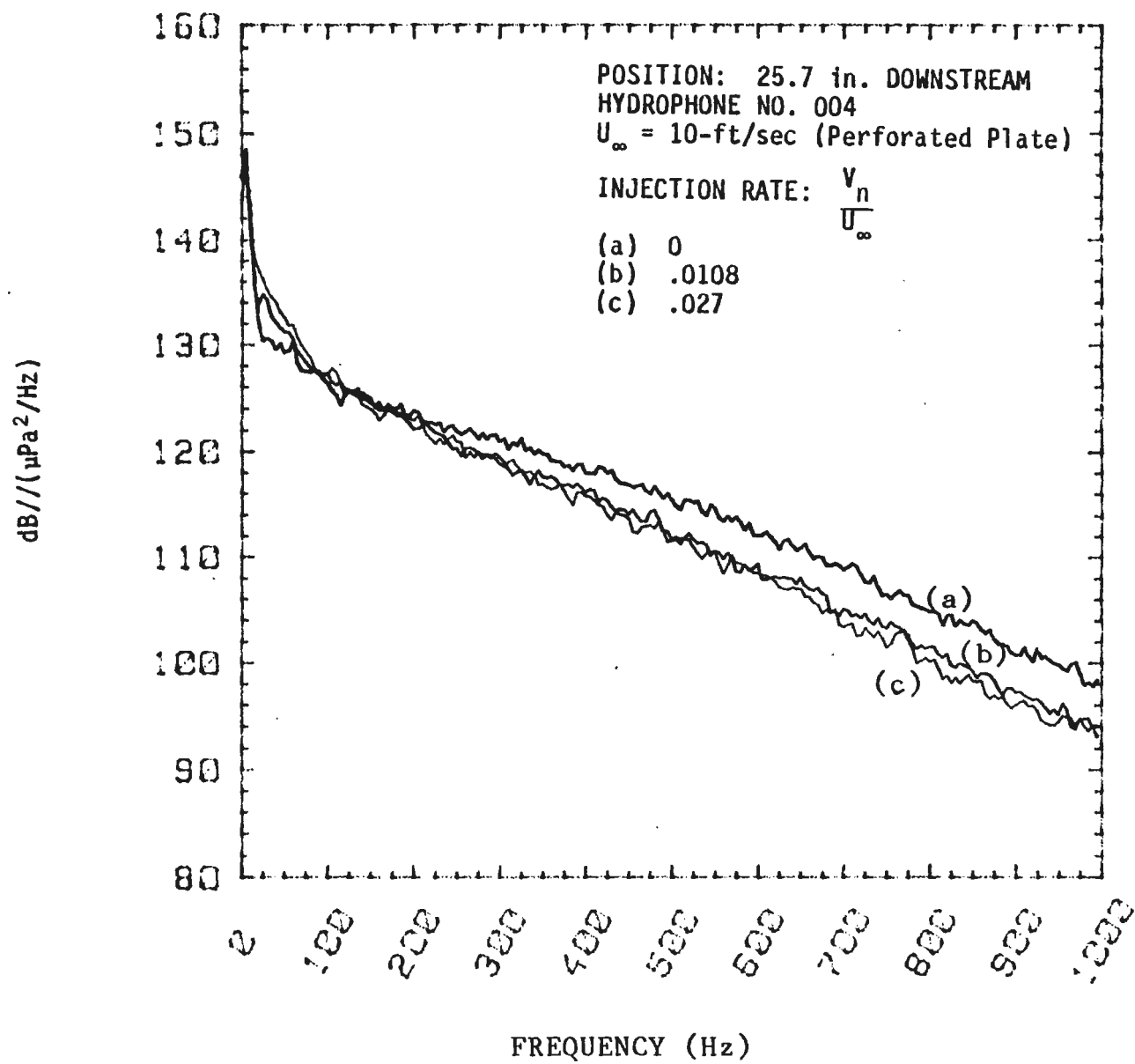

Figure 15 PRESSURE SPECTRAL DENSITY AT VARIOUS INJECTION RATES

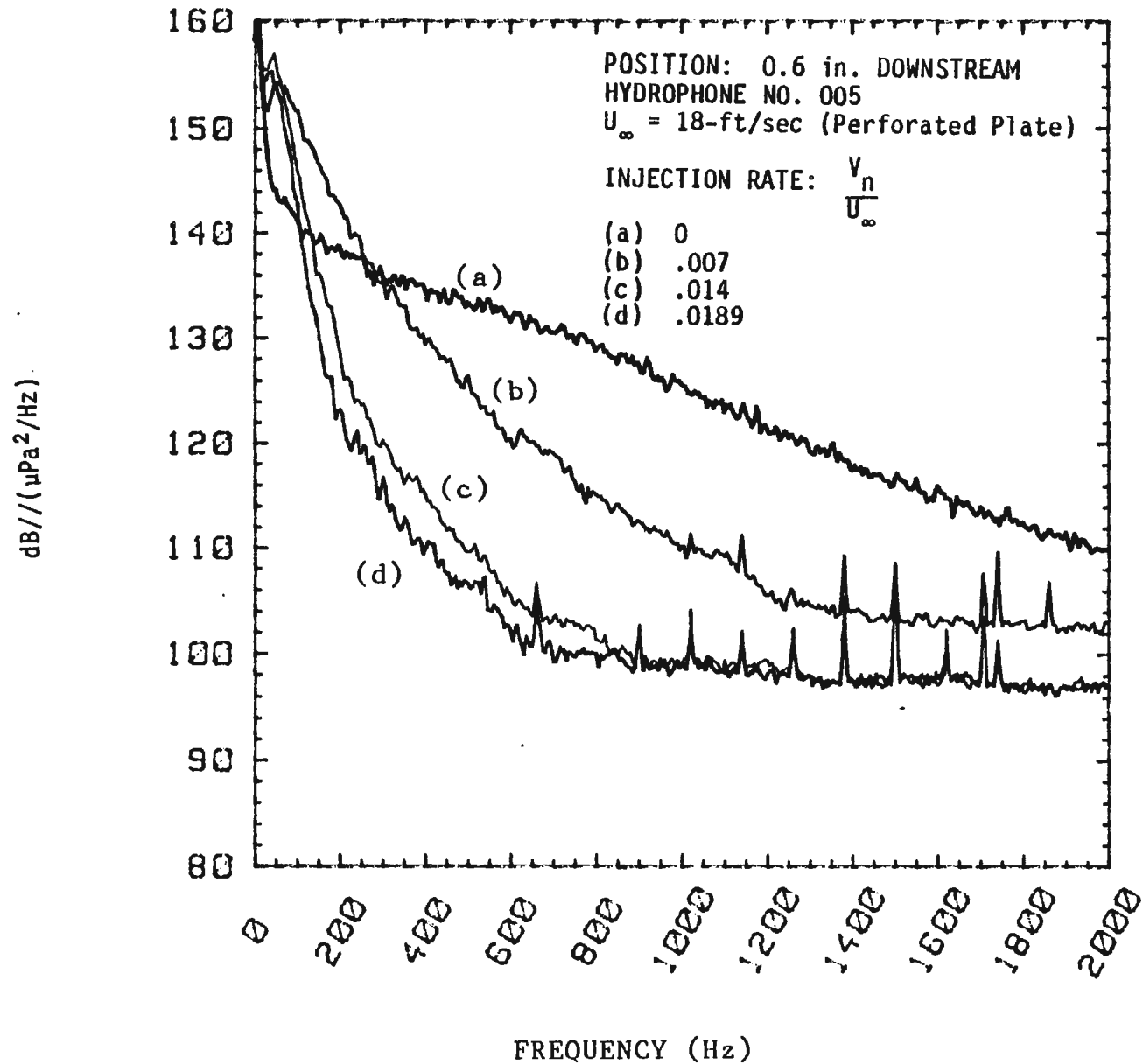

Figure 16 PRESSURE SPECTRAL DENSITY AT VARIOUS INJECTION RATES

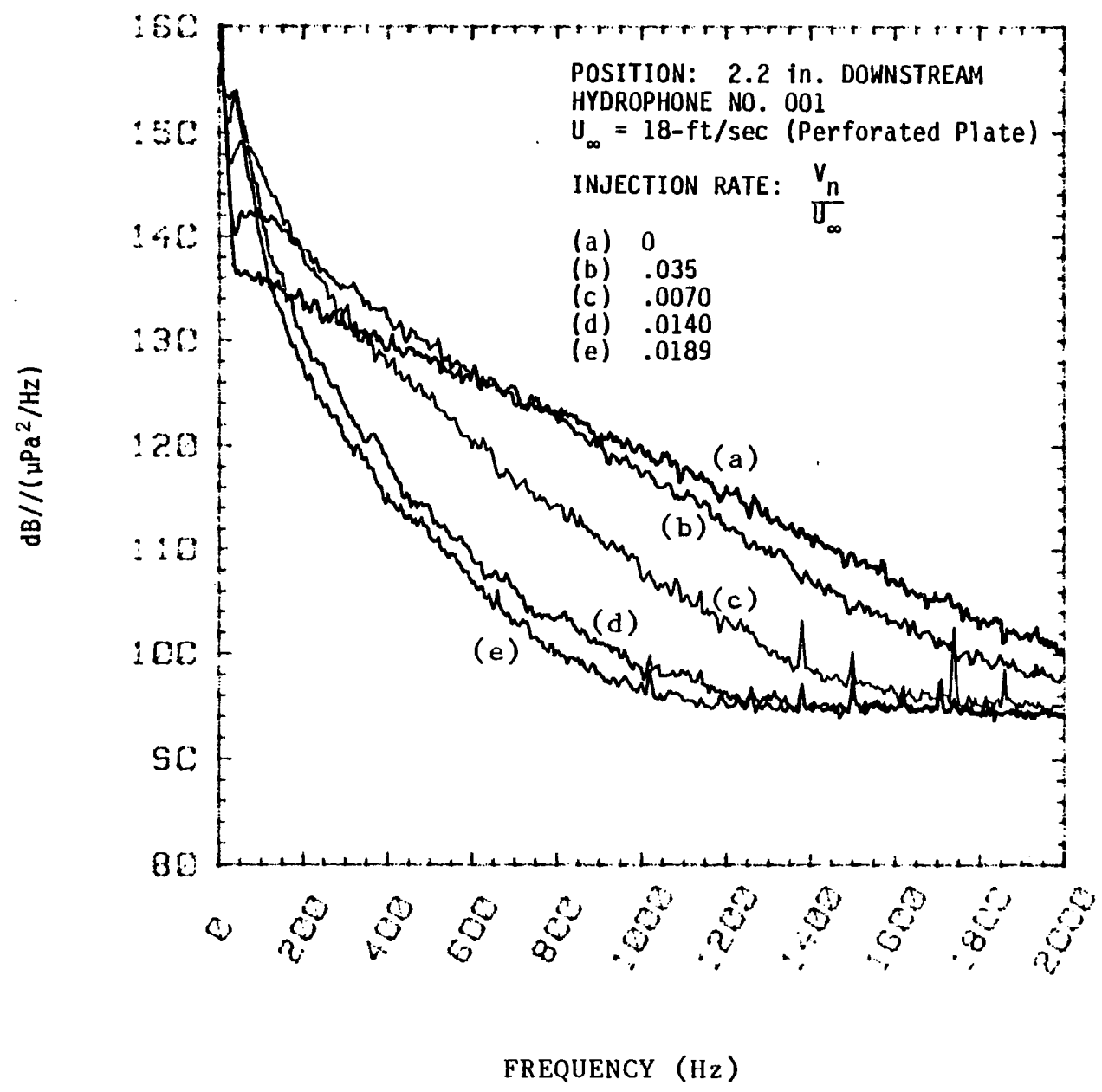
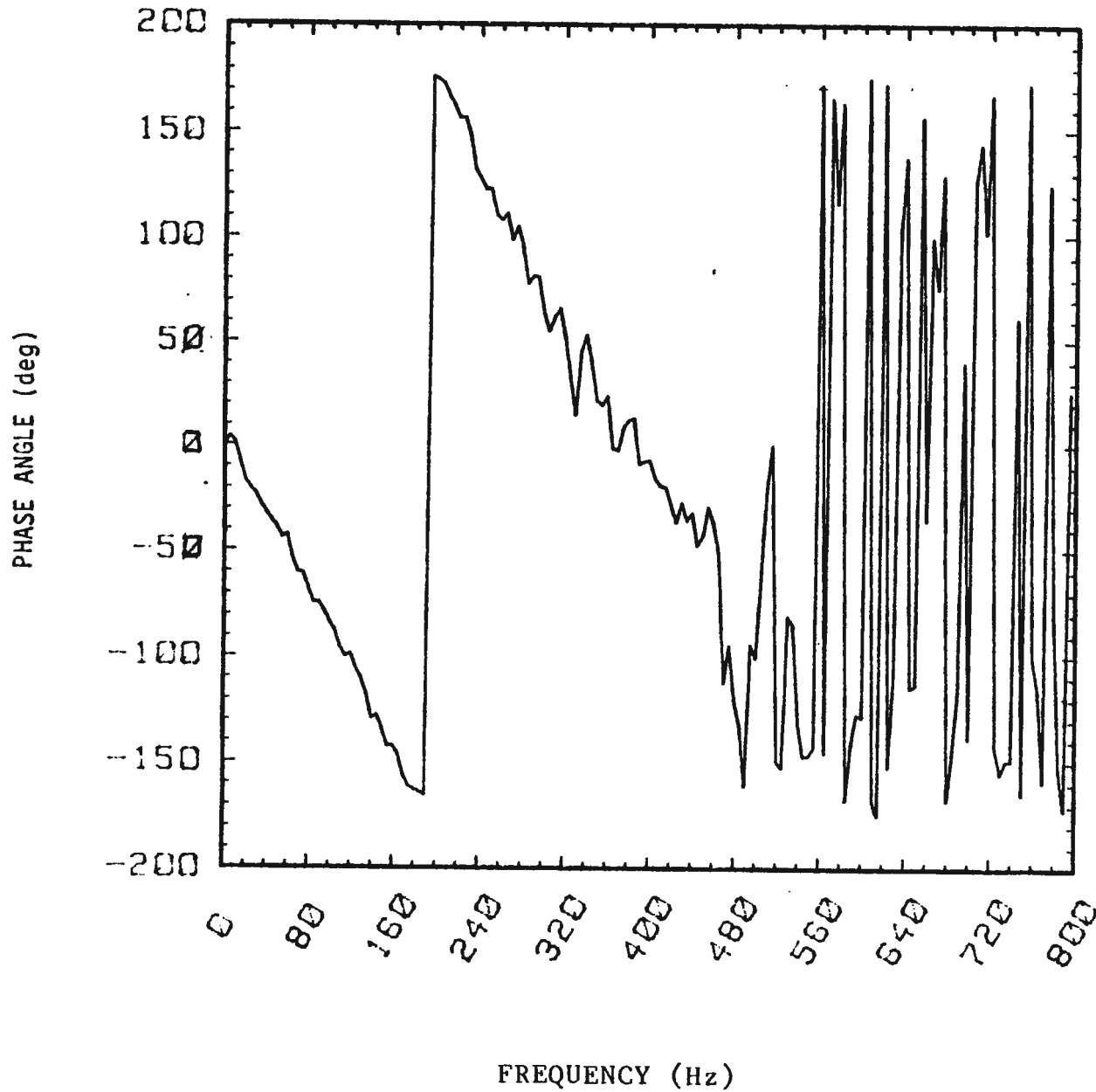

Figure 17 PRESSURE SPECTRAL DENSITY AT VARIOUS INJECTION RATES



SEPARATION: .20 in. at 0.6 in DOWNSTREAM
HYDROPHONES NO. 005 and 004
 $U_{\infty} = 10\text{-ft/sec}$ (Perforated Plate)

INJECTION RATE: $\frac{V_n}{U_{\infty}} = 0$

Figure 18a PHASE VELOCITY TRANSFER FUNCTION

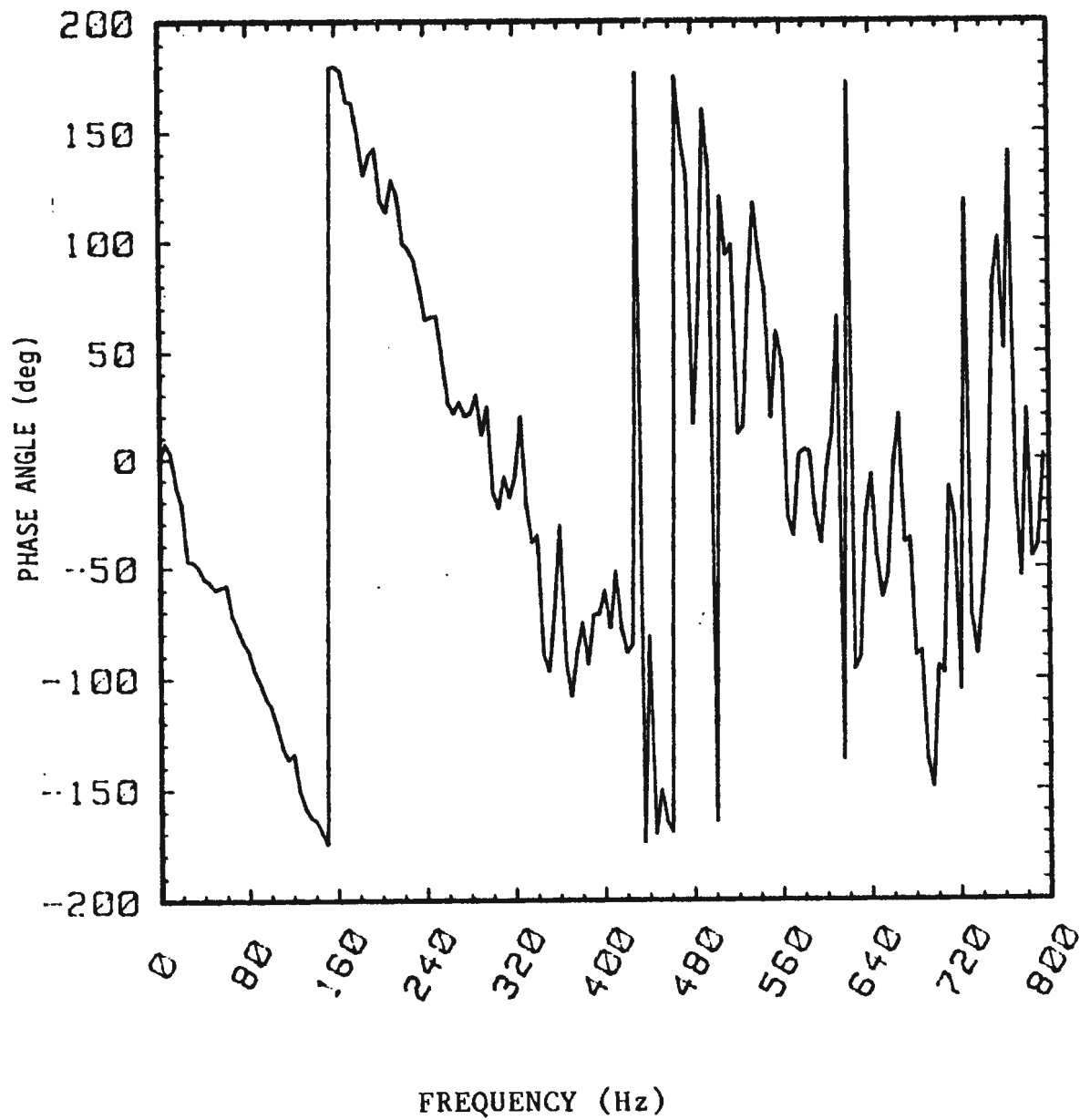

SEPARATION: .20 in. at 0.6 in DOWNSTREAM
HYDROPHONES NO. 005 and 004
 $U_{\infty} = 10\text{-ft/sec}$ (Perforated Plate)

INJECTION RATE: $\frac{V_n}{U_{\infty}} = .0055$

Figure 18b PHASE VELOCITY TRANSFER FUNCTION

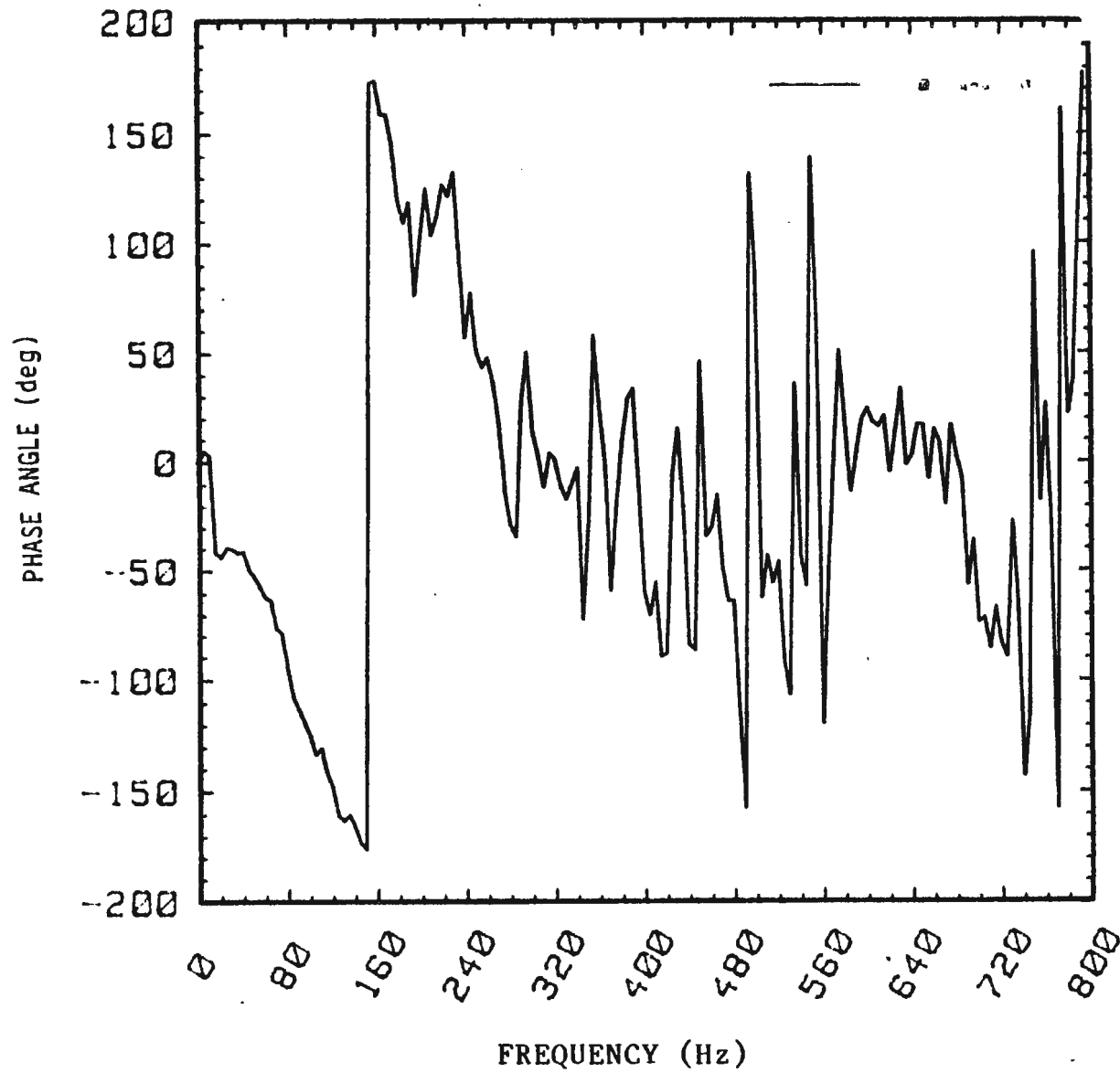

SEPARATION: .20 in. at 0.6 in DOWNSTREAM
 HYDROPHONES NO. 005 and 004
 $U_{\infty} = 10\text{-ft/sec}$ (Perforated Plate)

INJECTION RATE: $\frac{v}{u_{\infty}} = .0108$

Figure 18c PHASE VELOCITY TRANSFER FUNCTION

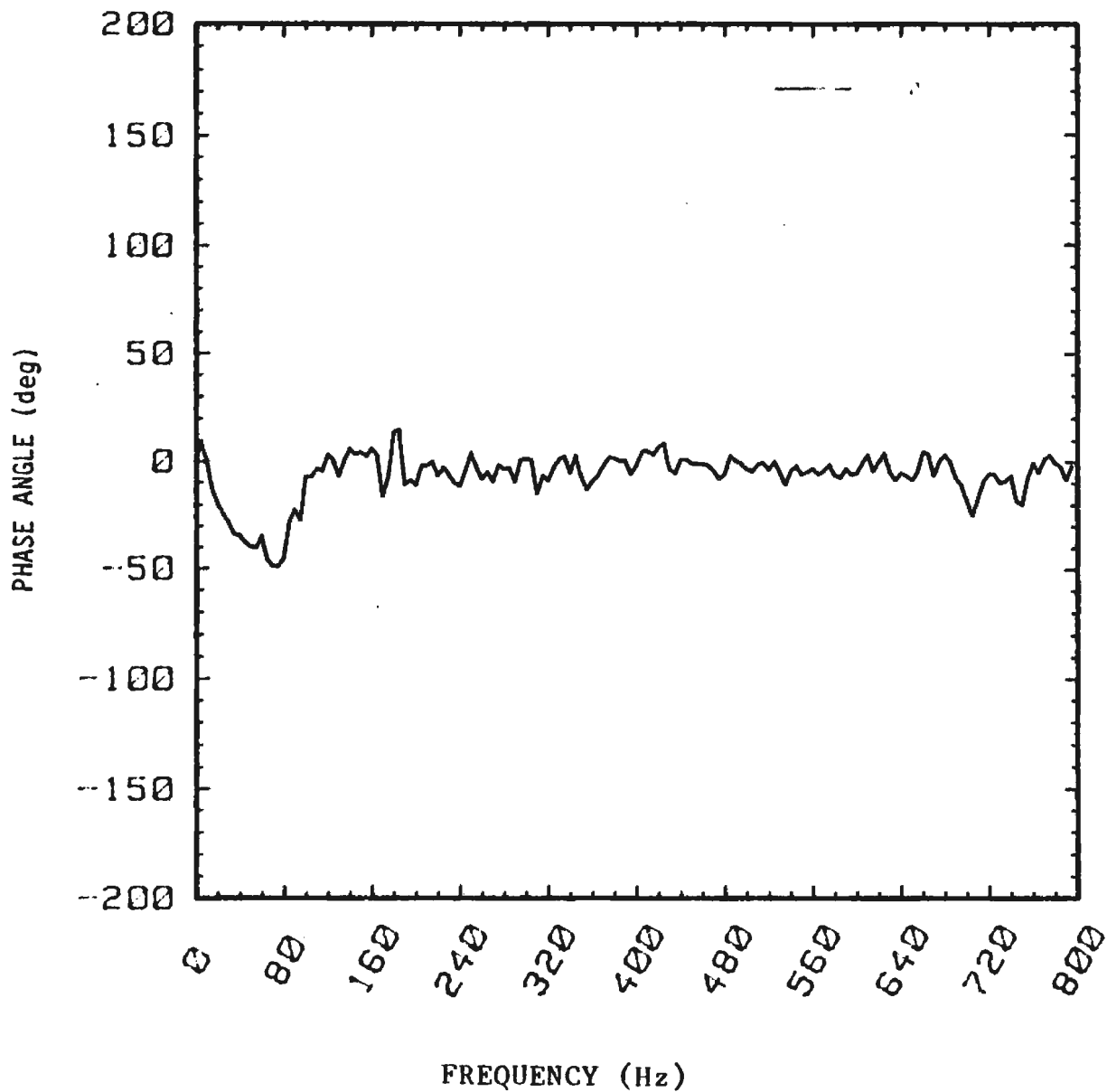

SEPARATION: .20 in. at 0.6 in DOWNSTREAM
HYDROPHONES NO. 005 and 004
 $U_{\infty} = 10\text{-ft/sec}$ (Perforated Plate)
INJECTION RATE: $\frac{V_n}{U_{\infty}} = .027$

Figure 18d PHASE VELOCITY TRANSFER FUNCTION

REFERENCES

1. L. M. Lyamshev, B. I. Chelnokov and A. G. Shusitov, "Pressure Fluctuations in a Turbulent Boundary Layer Under the Condition of Injection of a Continuous Medium Through a Permeable Boundary," Soviet Physics Acoustics 30(5), Pages 394 - 397, September - October 1984.
2. L. M. Lyamshev, B. I. Chelnokov and A. G. Shusitkov, "Pressure Fluctuations in the Turbulent Boundary Layer of a Water Flow with Gas Injection," Soviet Physics Acoustics 29(6), Pages 477 - 480, November - December 1983.
3. H. H. Schloemer, "Installation of a Rectangular Test Section for Acoustic Water Tunnel Studies of Flow Induced Noise," Naval Underwater Systems Center Technical Report 4763, 21 August 1974.
4. D. M. Chase, "Modeling the Wavevector - Frequency Spectrum of Turbulent - Boundary - Layer Wall Pressure," Journal of Sound and Vibration 70, Pages 29-67 (1980).
5. T. M. Farabee and M. J. Casarella, "Effect of Surface Irregularity on Turbulent boundary Layer Wall Pressure Fluctuations," ASME Journal of Acoustics, Vibration, Stress and Reliability in Design, Volume 106, Pages 343 - 350 (1984).
6. W. Keith, Private Communication, 1986, Calculations based on "Special Course on Concepts for Drag Reduction," AGARD Report No. 654, April 1977.
7. W. K. Blake, "Turbulent Boundary - Layer Wall-Pressure Fluctuations on Smooth and Rough Walls," Journal of Fluid Mechanics, Volume 44, Part 4, Pages 637 - 660 (1970).
8. T. M. Farabee, "An Experimental Investigation of Wall Pressure Fluctuations Beneath Non-Equilibrium Turbulent Flows," David W. Taylor Naval Ship Research & Development Center, Ship Acoustics Department Research & Development Report 86/047, May 1986.

TURBULENT BOUNDARY LAYER WALL PRESSURE FLUCTUATION
REDUCTIONS USING WATER INJECTION

Dr. Howard H. Schloemer
Elsa R. Payne
Submarine Sonar Department
TM No 86-1203
8 October 1986
J. O. A75600
Unclassified

DISTRIBUTION LIST

Internal

Codes: 02151 (New London (3))
02152 (Newport (3))
10X (K. Lima)
21
21 (W. Roderick)
213
213 (W. Strawderman)
2133 (3 Copies)
2133 (R. Christman, B. Cray, R. Gay)
(S. Ko, E. Payne (2 Copies), E. Recine)
214 (R. Elswick)
332 (R. Radlinski)
2141 (W. Keith)

Total: 24