

# ANTARES IS COMING TO LIFE\*

Hansjorg Jansen

Los Alamos National Laboratory  
P. O. Box 1663, MS E532  
Los Alamos, New Mexico 87545

## Summary

Antares is designed to focus 24 laser beams of 1.7-TW each onto a target of submillimeter size. Two grid-controlled electron guns and 96 laser cavities have to be energized by 10 powerful Marx generators in microseconds. During automatic alignment, 168 mirrors have to be moved. Laser energy is extracted in one nanosecond.

This paper presents a concise review of the basic design parameters of the laser fusion machine and the present status of the assembly and test activities. Up-to-date test results of the subsystems and of the first integrated beamline (12 beams) are discussed.

## Introduction

Antares, a laser fusion facility was planned in the early 70's as part of the National Inertial Fusion Program. It was designed to demonstrate whether or not scientific breakeven could be achieved with a 100-kJ, CO<sub>2</sub> laser.

During the Antares design phase, theoretical modeling and the results of Helios target experiments showed that hot electrons reduced the effectiveness of 10.6- $\mu\text{m}$  light and, worse, preheated the fuel. As a result, in 1980, Antares was changed from a 100-kJ/72-beam machine to a 40-kJ/24-laser beam machine. This facility (Fig. 1) has now been fully assembled. Almost all subsystems have been tested, and integration tests have been in progress since November, 1982. Completion of the facility is anticipated in October, 1983.

be of interest to summarize the basic design features and constraints.

Uniform energy deposition on the surface of submillimeter targets requires a certain minimum number of laser beams, for example, eight for the Helios facility. Larger beam numbers may be required as result of equipment or materials limitations. For Antares, the number of beams was dictated by the constraints of existing salt-window technology. One transmissive optical element is required to separate the high-pressure laser cavity of the power amplifier from the low-pressure target chamber. The best material suited for this purpose, which is optically compatible with 10.6- $\mu\text{m}$  light, is sodium chloride. State-of-the-art technology and experience at the time of the Antares design limited the window size to 45 cm for a pressure difference of 3 atm. From damage studies, it was known that hundreds of shots with a fluence of less than 3 J/cm<sup>2</sup> would not damage the salt windows. Taking into account safety factors, non-uniformities of spatial beam distribution, and the trapezoidal beam footprint, 24 beams with a size of about 1000-cm<sup>2</sup> each were chosen.

As a consequence of this choice, 24 laser cavities were required, 12 in each amplifier. The design of each cavity was based upon the choice of an optimum  $E/p = 10 \text{ V/cm torr}$  for a laser gas mix of CO<sub>2</sub>:N<sub>2</sub> = 4:1 to achieve a good pumping efficiency and provide a good safety margin relative to Townsend breakdown. A nominal pressure of 1800 torr was chosen to permit a reasonable pressure vessel design including the salt windows. The resulting required discharge voltage of 550 kV and electron-gun voltage of 525 kV were considered to be manageable.

A pump time to peak gain of about 3  $\mu\text{s}$  was selected as a compromise between desirable high pumping efficiency (short pulse), low current density (long pulse), and large circuit inductance (long pulse). The time constant of the relaxation of the upper laser level of 4.5  $\mu\text{s}$  makes short pump times more efficient. Lower current densities produce lower magnetic fields and thereby less undesirable electron-beam deflection. Large circuit inductances are easier and less costly to achieve.

A discharge-current density of 7A/cm<sup>2</sup> was chosen. It required an electron-beam-current density of 50 mA/cm<sup>2</sup> for primary gas ionization.

The design cavity gain is 2.7 m<sup>-1</sup>, requiring a length of the active gain medium of 3 m to achieve a single-pass gain length in the power amplifier of 8.0. To limit the azimuthal magnetic field to about 200 gauss (acceptable electron-beam deflection), each of the 12 power amplifier cavities is subdivided into four axial sections. A central electron-beam gun provides laser gas ionization

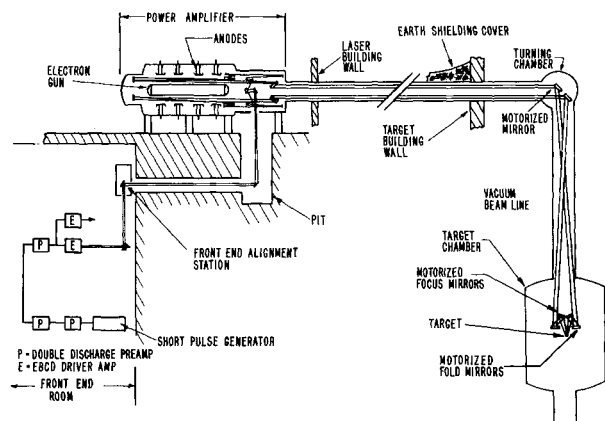

Fig. 1. Antares facility schematic.

## Key Design Features

Although it is not the intent of this paper to discuss the details of the Antares design, it may

\* Work performed under the auspices of the U. S. Department of Energy

# Report Documentation Page

Form Approved  
OMB No. 0704-0188

Public reporting burden for the collection of information is estimated to average 1 hour per response, including the time for reviewing instructions, searching existing data sources, gathering and maintaining the data needed, and completing and reviewing the collection of information. Send comments regarding this burden estimate or any other aspect of this collection of information, including suggestions for reducing this burden, to Washington Headquarters Services, Directorate for Information Operations and Reports, 1215 Jefferson Davis Highway, Suite 1204, Arlington VA 22202-4302. Respondents should be aware that notwithstanding any other provision of law, no person shall be subject to a penalty for failing to comply with a collection of information if it does not display a currently valid OMB control number.

1. REPORT DATE <b>JUN 1983</b>		2. REPORT TYPE <b>N/A</b>		3. DATES COVERED <b>-</b>	
4. TITLE AND SUBTITLE <b>Antares Is Coming To Life</b>				5a. CONTRACT NUMBER	
				5b. GRANT NUMBER	
				5c. PROGRAM ELEMENT NUMBER	
6. AUTHOR(S)				5d. PROJECT NUMBER	
				5e. TASK NUMBER	
				5f. WORK UNIT NUMBER	
7. PERFORMING ORGANIZATION NAME(S) AND ADDRESS(ES) <b>Los Alamos National Laboratory P. O. Box 1663, MS E532 Los Alamos, New Mexico 87545</b>				8. PERFORMING ORGANIZATION REPORT NUMBER	
9. SPONSORING/MONITORING AGENCY NAME(S) AND ADDRESS(ES)				10. SPONSOR/MONITOR'S ACRONYM(S)	
				11. SPONSOR/MONITOR'S REPORT NUMBER(S)	
12. DISTRIBUTION/AVAILABILITY STATEMENT <b>Approved for public release, distribution unlimited</b>					
13. SUPPLEMENTARY NOTES <b>See also ADM002371. 2013 IEEE Pulsed Power Conference, Digest of Technical Papers 1976-2013, and Abstracts of the 2013 IEEE International Conference on Plasma Science. Held in San Francisco, CA on 16-21 June 2013. U.S. Government or Federal Purpose Rights License</b>					
14. ABSTRACT					
15. SUBJECT TERMS					
16. SECURITY CLASSIFICATION OF:			17. LIMITATION OF ABSTRACT <b>SAR</b>	18. NUMBER OF PAGES <b>6</b>	19a. NAME OF RESPONSIBLE PERSON
a. REPORT <b>unclassified</b>	b. ABSTRACT <b>unclassified</b>	c. THIS PAGE <b>unclassified</b>			

through 48 Kapton-Aluminum, 50- $\mu$ m foil windows.

The design of the driver amplifier followed essentially the proven design of the dual-beam Helios module. The two discharges of the driver amplifier are controlled by two large-area electron beams produced by a double-sided, cold-cathode electron gun. Discharge and gun voltages are about 200 kV and 250 kV, respectively. Pumping time, current densities, E/p and gain are similar to those of the power amplifier. The cavity has a length of 200 cm and a diameter of 17 cm.

There are four different types of Marx generators to power the electron guns and discharges for the power amplifier and the driver amplifier. Their key design parameters are summarized in Table I.

### Operational Experience

The assembly and installation of the Antares equipment began in 1980 and continued until May, 1983. Testing of subsystems began in 1981, followed by integrated testing and check-out in 1982-83. To date, a reasonable operating experience has been obtained by running the driver amplifier and the power amplifier with their energy storage units. Many integration problems had to be overcome, particularly in the area of computer controls and diagnostics. Many high-voltage breakdown problems had to be solved, especially in the main electron-beam gun.

The following is a brief description of the equipment and of its operational performance.

Driver Amplifier. The driver amplifier is an on-axis, Cassegrain optical system where the beam passes three times through the gain medium (Fig. 2). A saturable-absorber gas cell at the input optically stabilizes the laser in spite of its high 3-pass gain of 18. The circular input beam of 2.5-cm diameter, 1-Joule, is amplified to an annular output beam of 15 cm O.D. x 9 cm I.D. with an energy of 100 Joules (Fig. 3).

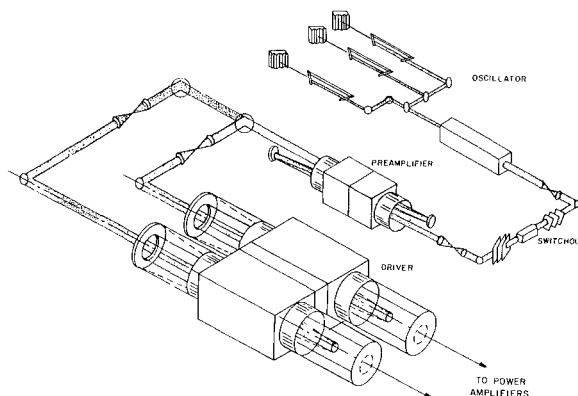

Fig. 2. Optical train of Antares Front-End.

TABLE I

KEY PARAMETERS OF THE ENERGY STORAGE SYSTEM

	$V_o$ (kV)	$V_L$ (kV)	I (kA)	Q (C)	L ( $\mu$ H)	C ( $\mu$ F)
Driver Cavity	400/600*	200/300	30/40	.06/.09	6.5	.14
Driver Gun	450/600	250/350	1.5/6.0	.06/.09	11	.14
Power Amplifier Cavity	1000/1200	450/550	150/200	~ 1	~ 2.4	.420
Power Amplifier Gun	525/600	475/550	20/25	~ 0.1	~ 3.5	.375

$V_o$  = Open circuit voltage

$V_L$  = Peak load voltage

I = Peak load current

Q = Charge transfer

L = Marx inductance

C = Marx capacitance

\* The first number indicates typical operating points. The second number indicates maximum design values.

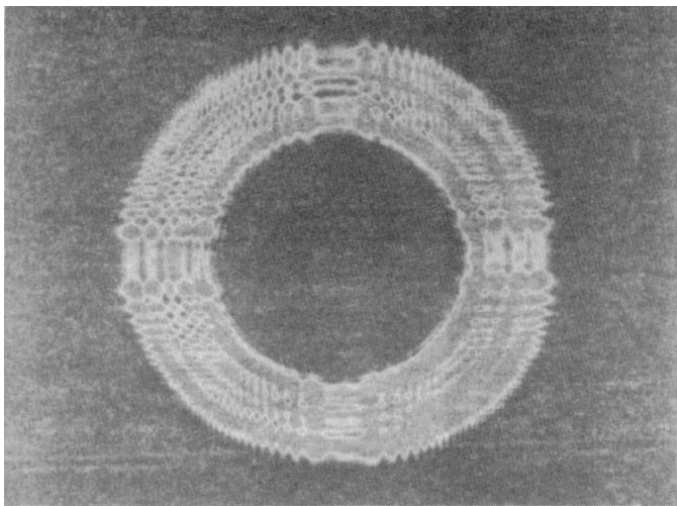

Fig. 3. Burn pattern produced by the driver-amplifier beam on photographic paper.

Both 200 x 17 x 17 cm cavities are pumped by Marx generators in a matched impedance ( $R = \sqrt{L/C}$ ) mode. Typical voltage and current traces are shown in Figure 4. The two-sided electron gun employs two longitudinal blades as cold-cathode emitters. The cathode structure is surrounded by a punched-metal sheet grid, which is biased through a grid resistor to control the gun current. The gun is driven by a Marx generator in an RC decay mode. Voltage and current traces are also shown in Figure 4.

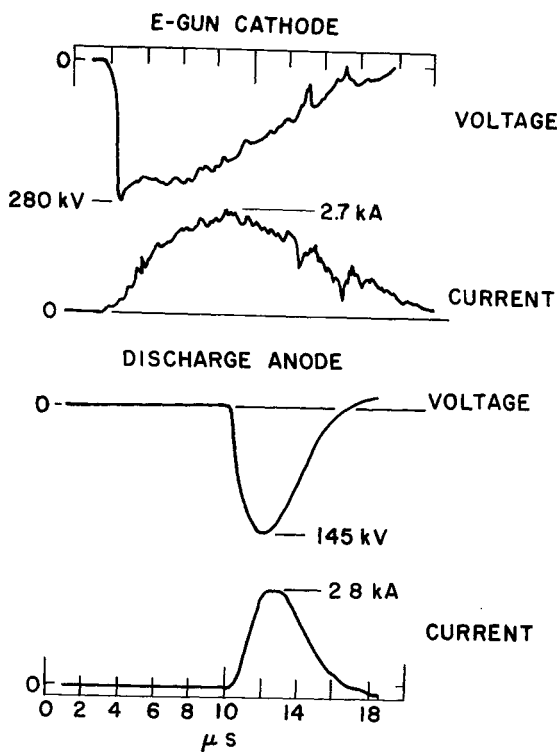

Fig. 4. Driver amplifier electrical characteristics.

The operational experience with the dual-beam driver amplifier has been excellent (Fig. 5). A total of 4000 shots at a discharge voltage of about 200 kV and a gun voltage of 250 kV have been fired without significant problems. There have been only two major equipment breakdowns.

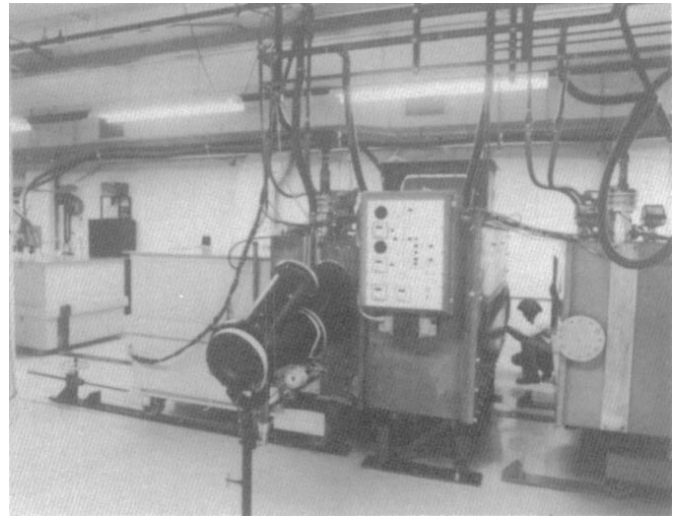

Fig. 5. View of the dual-beam driver amplifier with one discharge section removed.

**Power Amplifier.** The power amplifier is an off-axis, Cassegrain system where the beam passes twice through the gain medium (Fig. 6). A saturable-absorber gas cell provides for optical stability internal to the power amplifier and external between amplifier and target. The annular input beam of 100 Joules is split into 12 trapezoidal beamlets. Each beamlet of 2-cm-diameter enters the gain medium with an energy of 8.5 Joules and leaves it after the second pass with a trapezoidal cross-section of 36 x 33 cm and an energy of 1700 Joules.

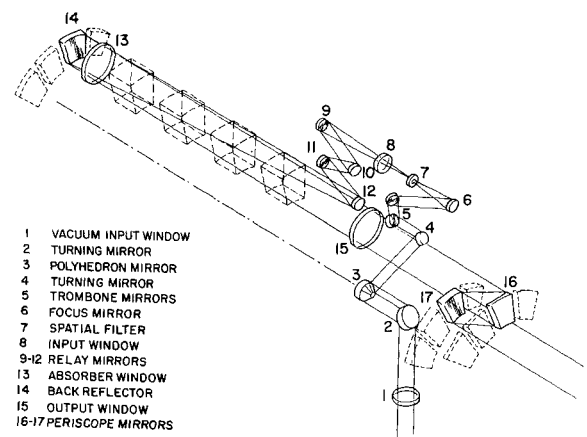

Fig. 6. Antares power amplifier optical schematic.

There are 48 cavities of 75 x 36 x 33 cm (Fig. 7). They are grouped in four axial sections with twelve annular sectors, each section fed by one Marx generator. The circuit is impedance matched, and typical voltage and current traces are shown in Figure 8. The power amplifier (Fig. 9) has been electrically tested at a pressure of 1700 torr with an anode voltage of 475 kV and current of 175 kA.

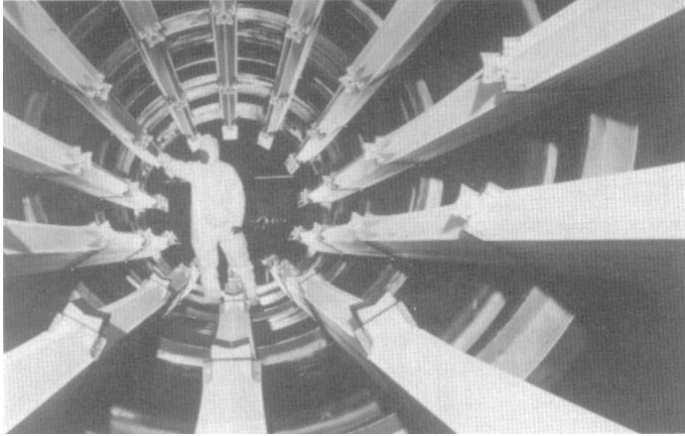

Fig. 7. View of 48 power amplifier cavities. The cavities are bounded by four circular anodes, 48 dielectric separators and (not shown) the central electron gun. The separator confines the discharge and prevents peripheral parasitic oscillations.

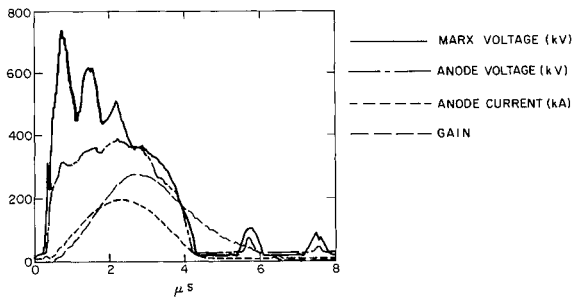

Fig. 8. Typical voltage and current curves of 12 annular discharges fed by one Marx generator through one common circular anode. The resulting gain is superimposed.

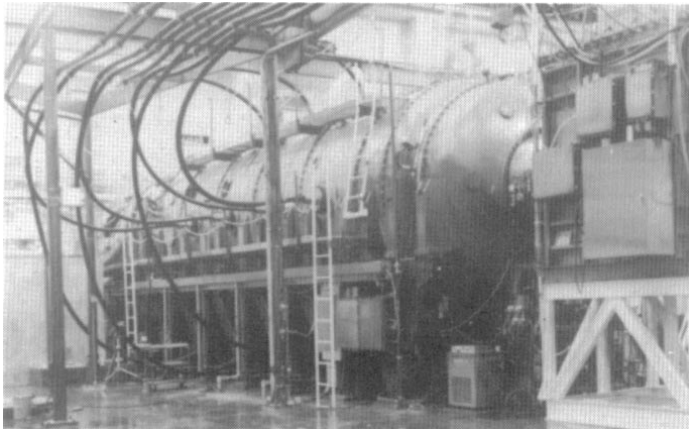

Fig. 9. The first power amplifier, fully operational.

The resulting gain was  $2.7 \text{ m}^{-1}$ , with a gain length product of  $g_0L = 8.2$ . The gain uniformity over the beam cross-section (Fig. 10) was excellent. Under these conditions, an energy output of 1.4 kJ is expected for one sector (Fig. 11). Extrapolating this output to full pressure and voltage predicts a power amplifier output of 36 kJ, within the original specifications of 35-40 kJ.

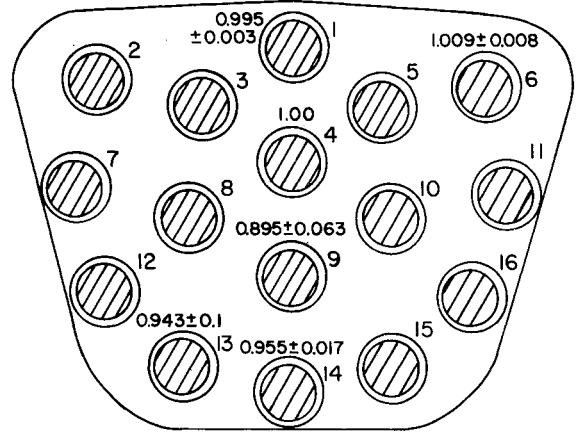

Fig. 10. Spatial gain distribution.

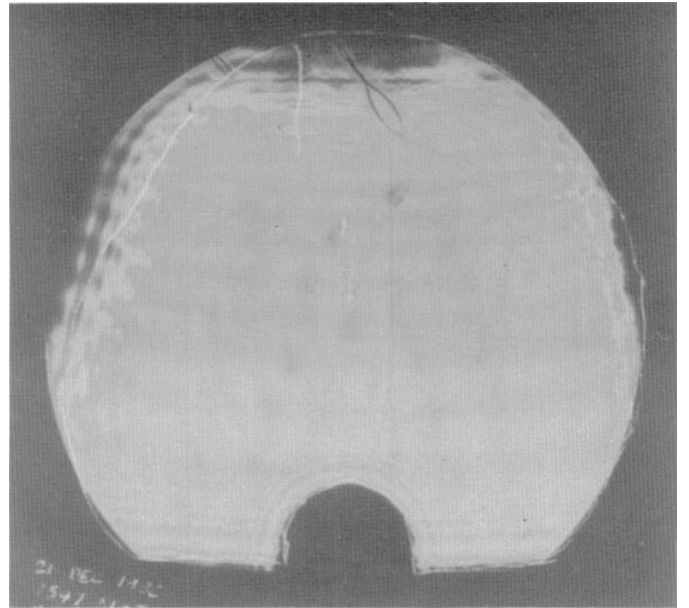

Fig. 11. The first single-beam energy shot. The trapezoidal shape of the photographic burn paper is clipped by a temporary round exit mirror frame. The contours of the input mirror are visible at the bottom.

There were significant problems with the central electron gun (Fig. 12). The original grid design of punched-metal sheet limited reliable gun operation to about 400 kV at an average field strength between grid and anode of 25 kV/cm. The estimated enhanced field at the grid surface was 75 kV/cm. A new grid design permits us to operate the gun routinely at voltages above 500 kV with an enhanced field of approximately 62 kV/cm at the grid.

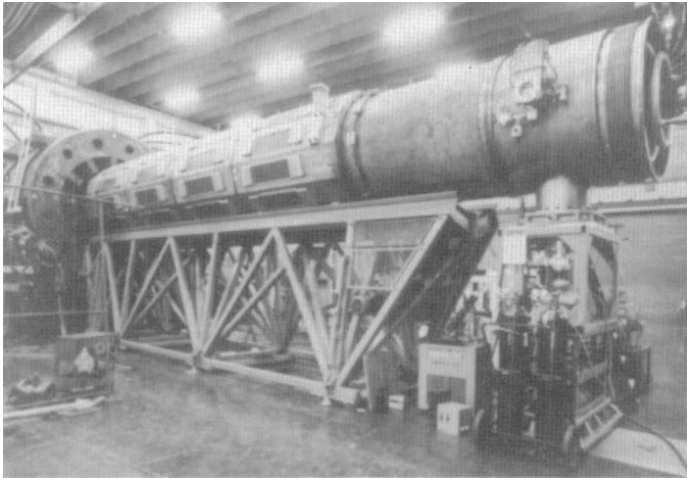

Fig. 12. View of the electron beam gun prior to insertion into the power amplifier. The gun is cryogenically pumped.

The gun and its Marx generator have operated at 90% of full voltage for more than 500 shots. Typical problems were grid resistor mechanical failures and a few (1% of shots or less) fast rise-time current runaways which are attributed to bushing flashover or emission site development on the grid which can cause grid-anode or grid-cathode closure.

The power amplifier and its four Marx generators have operated at 80% of full voltage for over 3000 shots. Typical problems were cable failures resulting from electron-gun dropout and overvoltage gap breakdown.

Target Chamber. Once the 24 beams leave the two high-pressure power amplifiers, they enter a vacuum system which contains all large mirrors necessary to guide the beams and focus them on the target. Large, 1.50-m-diameter tubes connect the power amplifiers to an 8-m-diameter x 7-m-long target chamber. A space frame holds 24 flat-folding and 24 parabolic focusing mirrors (Fig. 13). The target is irradiated from six sides by six beam clusters of four. A beam pointing and focusing accuracy at the target of 25  $\mu\text{m}$  is required, quite an optical achievement. The size of the focal spot is 300  $\mu\text{m}$ . The 1000- $\text{m}^3$ -target vacuum system is cryogenically pumped down to a pressure of  $2 \times 10^{-6}$  torr in about eight hours. Targets are inserted through an airlock and transported on an inclined track to their central position (Fig. 14). Final positioning of a target is performed through two large reference telescopes which have a resolution of 10  $\mu\text{m}$ .

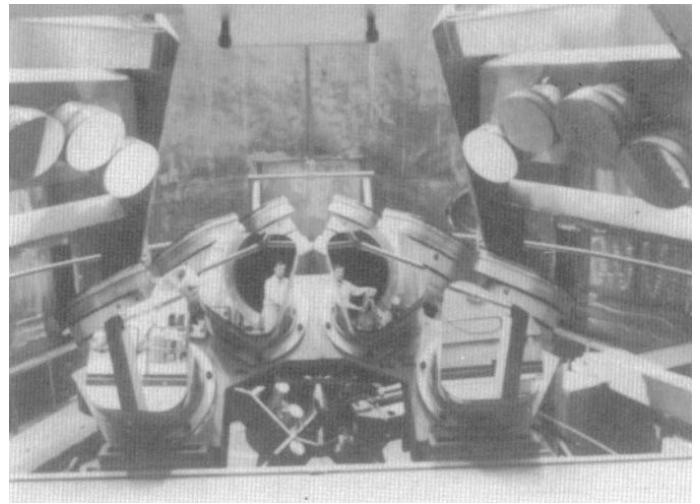

Fig. 13. Six sets of four folding mirrors, each surrounding the target position in the center, deflect the twenty-four beams onto six sets of parabolic focusing mirrors. Two are visible in the upper corner.

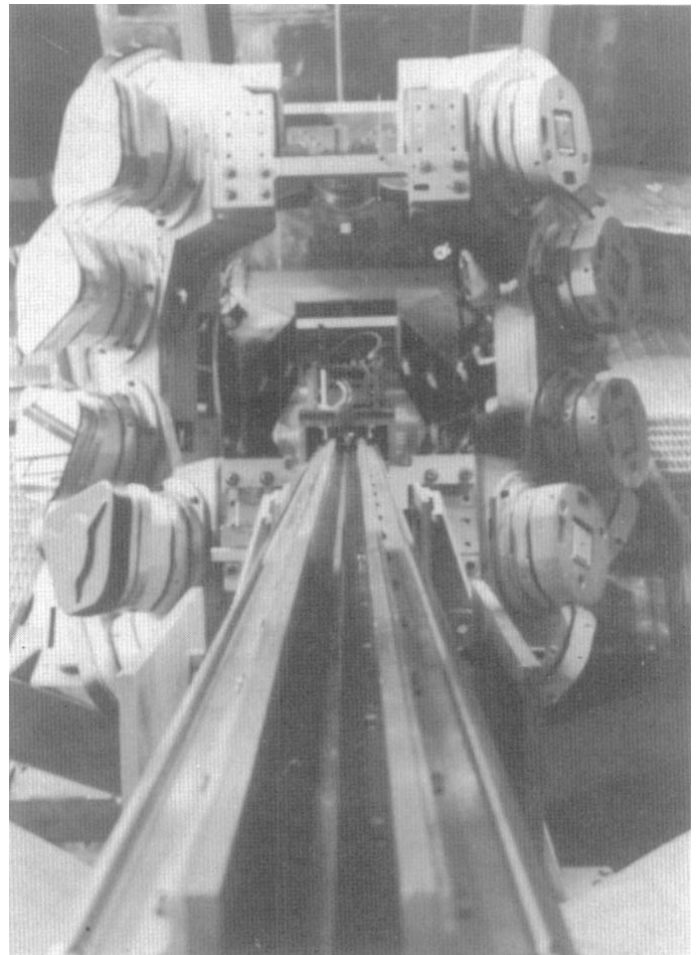

Fig. 14. The target is inserted through a vacuum lock into the target chamber. It is then transported on a cart and track to its central position. Arrays of folding mirrors surround the target. There are only mirror positioners mounted on the right array. These positioners are manipulated by stepping motors as part of the alignment system.

Instrumentation and Controls. The design of the instrumentation and control system is based on four premises:

1. There is no hard-wired logic. All logic decisions are made in software.
2. There are no traditional control panels. The interface between the operator and the machine is established via pressure-sensitive display screens. The displays are created and can be changed through software programming.
3. The control system is based on a network of distributed computers, with micros at the bottom of the hierarchy and minis at the top. The workhorse of the network is the LSI-11, which is located at the point of control. This means that a fully shielded microcomputer is mounted directly on top of a Marx generator enclosure. Programs are downloaded from the PDP-11/60s. Communication between the LSI-11 computers is handled by the minicomputers.
4. All data are digitized and transmitted over fiber-optic cables throughout the computer network (a total of 40 km of fibers). Data are displayed on screens and can be printed on hard copy.

Our operational experience with the control system relates only to the difficult startup period and not to final machine operation. As with any large control system, "debugging" has become a household word. In the "old days", electronics technicians or engineers could discover the problems and solve them. Now we need the services of several disciplines: people who understand analog-digital converters and micro-computers, people who understand the frequently erratic behavior of the minicomputers and the network, and people who wrote and/or understand the software.

There is no doubt that for as large a facility as Antares, a computer control system is considerably better and more versatile than the old hard-wired-logic-cum-panel/oscilloscope-display system once it is fully operational. In the meantime, however, teamwork and patience are required.

### Conclusion

During the testing of the Antares subsystems and their integration, most design goals have been attained. Not enough experience has been obtained to verify advertised lifetimes or meantimes between failures of the equipment. Some redesign was necessary, particularly to attain the voltage hold-off of the electron gun and to eliminate gain-limiting parasitic oscillations in the power amplifier. Based on limited gain and energy measurements in the driver and power amplifiers, we now believe that Antares will attain its goal, namely to deliver 35-40 terawatt pulses to inertial-fusion targets.

The author wishes to acknowledge the hard work and dedication of the entire Antares Team which made it possible to bring this facility into existence.