

# CHARACTERIZATION AND OPTIMIZATION OF A COMPACT, 1-MV, 6-kA RADIOGRAPHY SOURCE\*

R. J. Allen<sup>‡</sup>, G. Cooperstein, F. C. Young<sup>a</sup>, J. W. Schumer, D. D. Hinshelwood, D. Mosher  
*Plasma Physics Division, Naval Research Laboratory, Washington, DC, 20375 USA*

D. Holmberg, S. E. Mitchell  
*LLNL NTS Radiography, Bechtel Nevada, Las Vegas, NV, 89030-4134 USA*

## Abstract

The Hybrid Radiation Source (HRS) is a compact pulsed power generator consisting of a commercial flash x-ray system that has been retrofit with a custom front-end assembly, replacing a sealed glass tube. The HRS diode hardware consists of a tapered tungsten anode extended through an annular stainless steel cathode. The HRS has been successfully fielded, however, some source parameters, such as voltage, current, and source size, were not known. These parameters as well as the dose have now been measured with an array of diagnostics. Also, a circuit model has been developed to enable optimization and analysis of the complete system. The source size has been dramatically reduced by using a 1-mm-OD tapered anode. Anode heating has been shown to mitigate anode disintegration, allowing for multiple shots on a 1-mm-OD anode.

## I. DESCRIPTION OF THE HRS

The HRS consists of a Titan Pulse Sciences Division, 1-MV “Pulserad” flash x-ray source [1], which has been retrofit with a new stacked-ring insulator and cylindrical-diode front end. Bechtel Nevada designed the retrofit to improve on the Pulserad specifications of 55 mR at 1 m with a source size of 5 mm.

The main body of the HRS (Fig. 1a) is 54” long with a 20” OD. The Marx (b) consists of 22 stacked “pancake” elements held together by insulating rods. The Marx is enclosed in a fiberglass envelope that separates the 78 to 80-psig air-filled inside from the 20-psig SF<sub>6</sub>-filled outside. The Pulserad provides an uncalibrated “belly-band” capacitive voltage divider (c) to monitor the Marx voltage waveform.

The HRS stacked-ring insulator (Fig. 1d) and diode (f) were patterned after a Scandiflash model XT1200 source. A field shaper was added and the stacked-ring insulator was redesigned to withstand 1-MV, 50-ns voltage pulses. The HRS diode allows for easy anode replacement after

removing the x-ray window (h). After successful utilization in the field by Bechtel Nevada, the HRS was shipped to NRL for characterization and optimization. A ring with twin B-dot current probes was then installed (e).

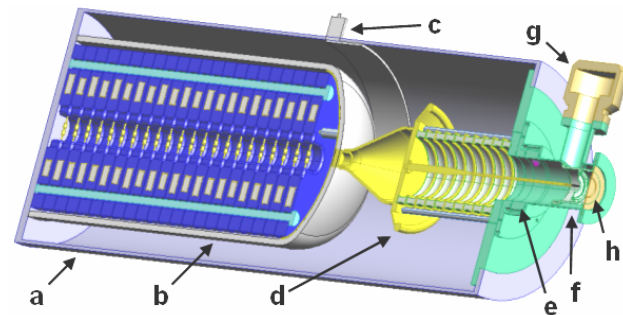

**Figure 1.** Diagram of the HRS indicating the (a) main body, (b) stacked Marx, (c) voltage monitor, (d) field shaper and stacked-ring insulator, (e) current monitor, (f) cylindrical diode, (g) vacuum pump, and (h) x-ray output window.

## II. ELECTRICAL CHARACTERISTICS OF THE HRS

A circuit model of the HRS Marx was developed to better understand the diode operation. X-ray photographs were taken of a pancake in order to derive the basic circuit model shown in Fig. 2. Each Marx pancake contains two stages of the 44-stage Marx. The Marx is normally charged to 35 kV giving an open-circuit voltage of 1.54 MV.

The charging inductors, L1-L4, have a value of about 4.4  $\mu$ H based on their geometry. Each Marx stage has five “doorknob” style capacitors in parallel with individual values of 2.36 nF from low-voltage measurements. Four small inductors, L5-L8, appear to be inserted between the Marx stage capacitors with values of  $\sim$ 100 nH from their geometry. It is speculated that these

\* Work supported by DOE through LLNL and Bechtel Nevada

<sup>‡</sup> email: allen@nrl.navy.mil

<sup>a</sup> Titan/Jaycor, McLean, VA 22102

# Report Documentation Page

*Form Approved*  
*OMB No. 0704-0188*

Public reporting burden for the collection of information is estimated to average 1 hour per response, including the time for reviewing instructions, searching existing data sources, gathering and maintaining the data needed, and completing and reviewing the collection of information. Send comments regarding this burden estimate or any other aspect of this collection of information, including suggestions for reducing this burden, to Washington Headquarters Services, Directorate for Information Operations and Reports, 1215 Jefferson Davis Highway, Suite 1204, Arlington VA 22202-4302. Respondents should be aware that notwithstanding any other provision of law, no person shall be subject to a penalty for failing to comply with a collection of information if it does not display a currently valid OMB control number.

|   |                                    |  |  |
|---|------------------------------------|--|--|
| 1. REPORT DATE<br><b>JUN 2003</b>   | 2. REPORT TYPE<br><b>N/A</b>       | 3. DATES COVERED<br><b>-</b>             |  |
| 4. TITLE AND SUBTITLE<br><b>Characterization And Optimization Of A Compact, 1-Mv, 6-Ka Radiography Source</b>   |                                    | 5a. CONTRACT NUMBER                      |  |
|   |                                    | 5b. GRANT NUMBER                         |  |
|   |                                    | 5c. PROGRAM ELEMENT NUMBER               |  |
| 6. AUTHOR(S)  |                                    | 5d. PROJECT NUMBER                       |  |
|   |                                    | 5e. TASK NUMBER                          |  |
|   |                                    | 5f. WORK UNIT NUMBER                     |  |
| 7. PERFORMING ORGANIZATION NAME(S) AND ADDRESS(ES)<br><b>Plasma Physics Division, Naval Research Laboratory, Washington, DC, 20375 USA</b>  |                                    | 8. PERFORMING ORGANIZATION REPORT NUMBER |  |
| 9. SPONSORING/MONITORING AGENCY NAME(S) AND ADDRESS(ES)   |                                    | 10. SPONSOR/MONITOR'S ACRONYM(S)         |  |
|   |                                    | 11. SPONSOR/MONITOR'S REPORT NUMBER(S)   |  |
| 12. DISTRIBUTION/AVAILABILITY STATEMENT<br><b>Approved for public release, distribution unlimited</b>   |                                    |  |  |
| 13. SUPPLEMENTARY NOTES<br><b>See also ADM002371. 2013 IEEE Pulsed Power Conference, Digest of Technical Papers 1976-2013, and Abstracts of the 2013 IEEE International Conference on Plasma Science. IEEE International Pulsed Power Conference (19th). Held in San Francisco, CA on 16-21 June 2013. U.S. Government or Federal Purpose Rights License, The original document contains color images.</b>  |                                    |  |  |
| 14. ABSTRACT<br><b>The Hybrid Radiation Source (HRS) is a compact pulsed power generator consisting of a commercial flash x-ray system that has been retrofit with a custom frontend assembly, replacing a sealed glass tube. The HRS diode hardware consists of a tapered tungsten anode extended through an annular stainless steel cathode. The HRS has been successfully fielded, however, some source parameters, such as voltage, current, and source size, were not known. These parameters as well as the dose have now been measured with an array of diagnostics. Also, a circuit model has been developed to enable optimization and analysis of the complete system. The source size has been dramatically reduced by using a 1-mm-OD tapered anode. Anode heating has been shown to mitigate anode disintegration, allowing for multiple shots on a 1-mm-OD anode.</b> |                                    |  |  |
| 15. SUBJECT TERMS   |                                    |  |  |
| 16. SECURITY CLASSIFICATION OF:   |                                    |  | 17. LIMITATION OF ABSTRACT<br><b>SAR</b> |
| a. REPORT<br><b>unclassified</b>  | b. ABSTRACT<br><b>unclassified</b> | c. THIS PAGE<br><b>unclassified</b>      |  |
|   |                                    |  | 18. NUMBER OF PAGES<br><b>4</b>          |
|   |                                    |  | 19a. NAME OF RESPONSIBLE PERSON          |

inductors were added to widen the output pulse. The switches are gas spark gaps with brass electrodes and ~2.5-mm gaps.

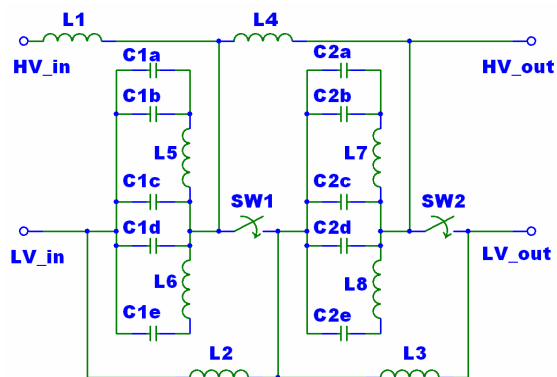

Figure 2. Basic circuit model for an HRS Marx pancake.

The capacitors are likely composed of a class-3 dielectric with a strongly voltage-dependent capacitance. A good match to dummy-load measurements was found using the voltage dependence of a 30-kV rated, Murata Z5V doorknob capacitor multiplied by a factor of 0.45 in the model. An initial capacitance of 2.4 nF was assumed because this is a standard value and may have been the original value before aging.

The switches were modeled by an inductance of 18.5 nH (including inductance of stage connections), a capacitance of 0.1 nF (including pancake-to-pancake capacitance), and a final resistance of 0.25  $\Omega$  (after a 3-ns exponential transition). The switching time of successive stages was set for a fixed interval of 0.6 ns. An extra 60-nH inductor was added to the model between the outer two capacitors in each stage (e.g., C1a and C1b in Fig. 2) to better match the tail of the pulse. The connection between the Marx and the load was modeled as an inductor. This inductance was estimated from the geometry to be 421 nH for a diode load and 299 nH for the dummy load. The measured belly-band voltage is in good agreement with the voltage calculated using the transmission-line code, Bertha [2], for a 147- $\Omega$  dummy load as shown in Fig. 3.

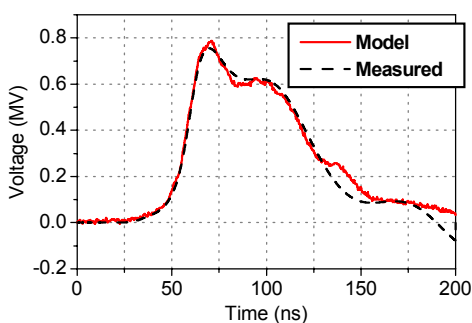

Figure 3. Comparison of modeled and measured belly-band voltages for a 147- $\Omega$  dummy load.

### III. CHARACTERIZATION OF THE ORIGINAL HRS DIODE

The original HRS diode consists of a 4-mm-OD tungsten anode with an 18-mm-long taper to a 1-mm-OD blunt tip that protrudes 9.3 mm through a 25-mm-ID, 1.2-mm-thick stainless steel cathode with a knife edge as shown in Fig. 4. The anode tip is 25 mm from a 0.81 mm thick aluminum x-ray window.

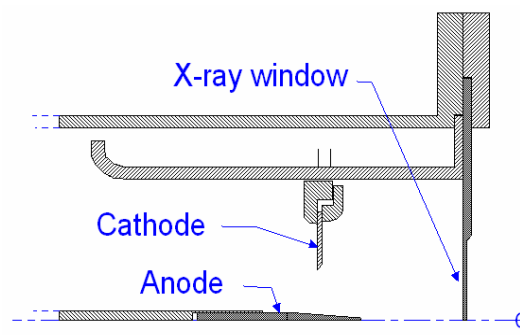

Figure 4. Geometry of the original HRS diode.

The HRS with a 4-mm-OD anode proved to be a reliable source, good for at least 15 shots before erosion of the anode became a concern. In a series of eight shots on the same anode (without breaking vacuum), a pocket dosimeter on axis at 0.6 m from the anode tip read  $174 \pm 5$  mR. The dose calculated with the code CYLTRAN [3] using the measured current and voltage was 200 mR, in reasonable agreement with the dosimeter.

The diode voltage was determined by inductively correcting the belly-band voltage (after a slight, 1000-ns droop correction). The diode voltage, current, impedance, and x-ray signal from a Si-PIN diode for a typical shot with a 4-mm-OD anode are shown in Fig. 5. The x-ray signal peaks after peak voltage (800 kV) and before peak current (6.8 kA). The voltage falls to ~700 kV at the time of peak x-rays. The FWHM of the x-ray signal is 17 ns.

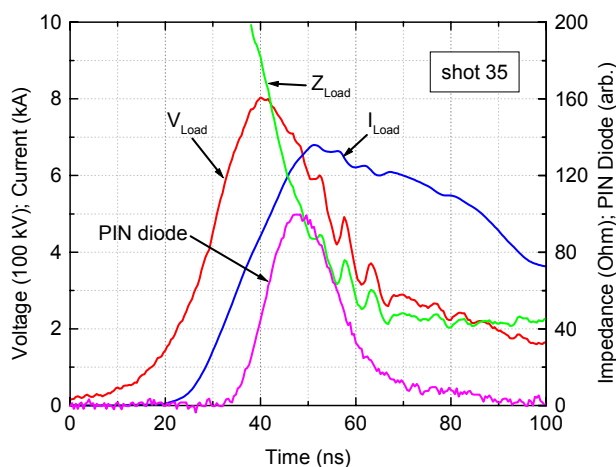

Figure 5. Typical signals from the original HRS diode.

The peak diode voltage was verified using an array of GaAs photoconducting detectors (PCDs) filtered by 3.1 mm of copper, 3.1 mm of tungsten, or 6.3 mm of tungsten. The voltage corresponding to the ratio of these PCD signals has been calculated and experimentally verified.[4] Ratios of PCD signals for 3.1-mm W/3.1-mm Cu and for 6.3-mm W/3.1-mm Cu were used to deduce a peak load voltage of  $825 \pm 40$  kV (based on  $\pm 10\%$  uncertainties in the measurements), which agrees with the electrical measurement of  $800 \pm 40$  kV.

The source diameter, measured with a tungsten rolled edge and x-ray film, is 4.16 mm (LANL definition). The line spread fits a uniformly-emitting disk of 2.0-mm radius as shown in Fig. 6. A pinhole camera image recorded at  $45^\circ$  to the rod axis and stretched by 2X to approximate a side view is shown in Fig. 7. The overlay of the rod outline shows that x-rays are produced along the entire taper of the rod. Some blur is due to the size of the pinhole, whose projection is also overlaid on the image.

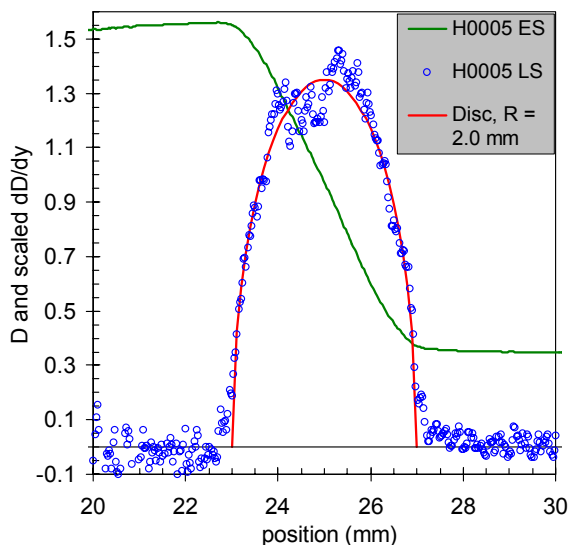

Figure 6. Rolled-edge measurement of 4-mm-OD anode.

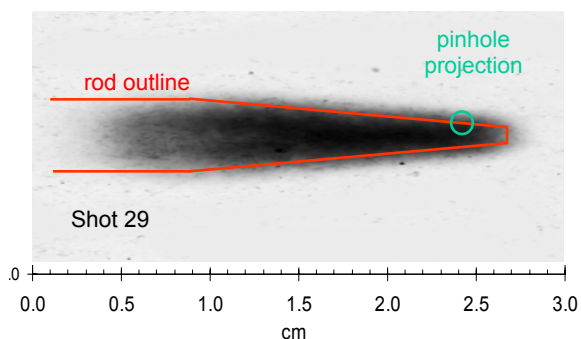

Figure 7. Pinhole camera image of 4-mm-OD anode.

Extensive PIC simulations of the diode have shown that the electron beam is only weakly pinched with electrons spreading out over an anode length of nearly twice the AK gap. The steady-state impedance of the diode, calculated using the PIC code MAGIC [5], depends strongly on the extent of ion emission from the anode surface, as shown in Fig. 8 for the cases of no ion emission, ion emission limited to regions downstream of the cathode, and ion emission allowed along the entire anode. Superimposed on Fig. 8 are points representing data from shot 35 (see Fig. 5) spaced 7-ns apart, beginning at the time of peak voltage.

The cathode turn-on process appears slow, taking about 40 ns, probably due to the weak electric fields on the cathode. The ion turn-on process is also slow and occurs during the main x-ray pulse. Ion emission from the anode is likely when electrons heat the anode above some threshold temperature. Time-resolved modeling of this diode is difficult because it is source limited by highly nonlinear threshold effects, although the PIC code LSP [6] has been used with some limited success.

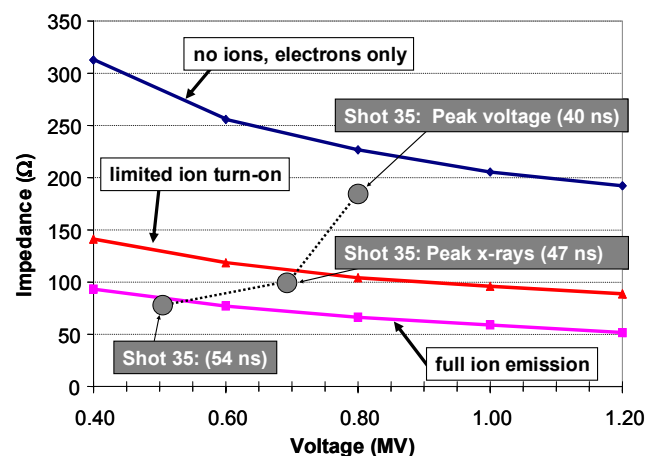

Figure 8. Steady-state impedance calculations of the original HRS diode with different levels of ion emission.

The HRS system has also been modeled by attaching an existing cylindrical-diode circuit model [7] to the Marx circuit model described earlier. A good match to the measured current was found for appropriate electron and ion turn-on times and velocities.

#### IV. OPTIMIZATION OF THE HRS DIODE

Progress has been made in optimizing the HRS diode in terms of the radiographic figure-of-merit (FOM), defined as the dose at 1 m divided by the source size. The main focus has been on reducing the source size by reducing the anode diameter while adjusting the cathode ID to control the voltage and dose.

The largest FOMs on the HRS were achieved with a 1.0-mm-OD anode, tapered to either a point or to a 0.5-mm blunt tip. The edge-spread and line-spread measurements for a 1.0-mm anode, tapered over 15 mm to a point, with a 10-mm-ID cathode are shown in Fig. 9. The source approximates a 0.4-mm-radius, uniformly-emitting disk. The LANL defined source diameter, which includes the effects of the “wings” on the sides of the line-spread, was 1.19 mm. Although the dose was lower for the 1-mm-OD anode, the FOM increased by a factor of seven. If one chooses the equivalent uniform-disk size to define the FOM, then the increase is a factor of 16.

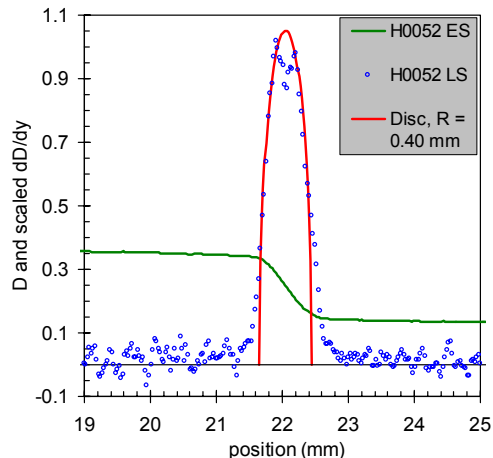

Figure 9. Rolled-edge measurement of 1-mm-OD anode.

Heating the anode to about 350°C for a few hours prior to the shot has been shown to increase the impedance and the off-axis dose for 1-mm-OD anodes. The dose was increased by about 9% to the side but relatively unchanged in the forward direction. It is speculated that a longer taper could improve the on-axis dose.

An unexpected benefit of anode heating is increased anode lifetime. Unheated, 1-mm-OD anodes either disintegrated or were splayed (depending on geometry) after a single shot. However, heated anodes survived with minimal damage allowing several shots on the same anode. With a 14-mm-ID cathode and a 1-mm-OD anode tapered over 7.5 mm to a blunt tip, the same anode was used for three successive shots with similar on-axis doses. After three shots, the anode base was bent and the tip was slightly frayed. In contrast, the OD of an unheated anode doubled on a single shot as shown in Fig. 10.

Pinhole-camera images of this heated, 1-mm-OD anode reveal emission from a few cm length of the anode as shown in Fig. 11. This leads to the speculation that increasing the taper length to include the whole emission area would increase the on-axis dose.

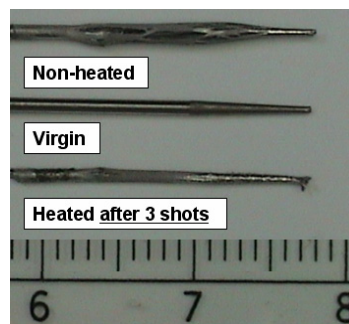

Figure 10. Comparison of non-heated (after one shot), virgin, and heated (after three shots) 1-mm-OD anodes.

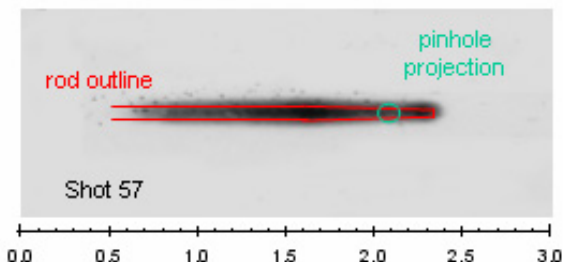

Figure 11. Pinhole image of heated, 1-mm-OD anode.

## V. SUMMARY

The HRS retrofit to the Pulserad system reduced the on-axis source diameter to 4-mm while increasing the dose at 1 m to 63 mR and provided for easily replaceable anodes. The HRS diode voltage peaked at 800 kV and then decreased to about 700 kV at peak x-ray emission.

The FOM increased sevenfold by reducing the anode OD from 4 mm to 1 mm. Multi-shot operation with a 1-mm anode was demonstrated using modest anode heating.

## VI. REFERENCES

- [1] Model 43710A, <http://www.titanpsd.com>.
- [2] D. D. Hinshelwood, NRL Memorandum Report 5185 (1983), unpublished.
- [3] J. A. Halbleib and T. A. Mehlhorn, Nucl. Sci. Eng. 92 (1986) 338-339.
- [4] J. E. Rauch, “The GaAs PCD Ratio Voltage Monitor”, Maxwell Technologies Report MTS300-149, 1998, unpublished.
- [5] B. Goplen, L. Ludeking, D. Smithe, G. Warren, Comp. Phys. Comm. 87, 54 (1995).
- [6] D.R. Welch, D.V. Rose, B.V. Oliver, and R.E. Clark, Nucl. Instrum. Methods Phys. Res. A 464, 134 (2001).
- [7] S. B. Swanekamp, et al., “Particle-in-Cell Simulations of High-Power Cylindrical Electron Beam Diodes”, Phys. Plasma Vol. 7, pp. 5214-5222, 2000.