

NAVAIR / MITRE / SEI (NMS) COLLABORATION

**Presented to
Acquisition of Software-Intensive
Systems Conference**

28-30 January 2003

**Software Engineering Institute
Carnegie Mellon University**

MITRE

NAVAIR

Report Documentation Page

*Form Approved
OMB No. 0704-0188*

Public reporting burden for the collection of information is estimated to average 1 hour per response, including the time for reviewing instructions, searching existing data sources, gathering and maintaining the data needed, and completing and reviewing the collection of information. Send comments regarding this burden estimate or any other aspect of this collection of information, including suggestions for reducing this burden, to Washington Headquarters Services, Directorate for Information Operations and Reports, 1215 Jefferson Davis Highway, Suite 1204, Arlington VA 22202-4302. Respondents should be aware that notwithstanding any other provision of law, no person shall be subject to a penalty for failing to comply with a collection of information if it does not display a currently valid OMB control number.

1. REPORT DATE JAN 2003	2. REPORT TYPE	3. DATES COVERED 00-00-2003 to 00-00-2003			
4. TITLE AND SUBTITLE NAVAIR/MITRE/SEI (NMS) Collaboration		5a. CONTRACT NUMBER			
		5b. GRANT NUMBER			
		5c. PROGRAM ELEMENT NUMBER			
6. AUTHOR(S)		5d. PROJECT NUMBER			
		5e. TASK NUMBER			
		5f. WORK UNIT NUMBER			
7. PERFORMING ORGANIZATION NAME(S) AND ADDRESS(ES) Carnegie Mellon University, Software Engineering Institute, Pittsburgh, PA, 15213		8. PERFORMING ORGANIZATION REPORT NUMBER			
9. SPONSORING/MONITORING AGENCY NAME(S) AND ADDRESS(ES)		10. SPONSOR/MONITOR'S ACRONYM(S)			
		11. SPONSOR/MONITOR'S REPORT NUMBER(S)			
12. DISTRIBUTION/AVAILABILITY STATEMENT Approved for public release; distribution unlimited					
13. SUPPLEMENTARY NOTES					
14. ABSTRACT					
15. SUBJECT TERMS					
16. SECURITY CLASSIFICATION OF:			17. LIMITATION OF ABSTRACT	18. NUMBER OF PAGES	19a. NAME OF RESPONSIBLE PERSON
a. REPORT unclassified	b. ABSTRACT unclassified	c. THIS PAGE unclassified	Same as Report (SAR)	41	

OVERVIEW

- **NAVAIR Software Intensive Systems Overview**
 - Business Profile
 - 1999 Software Business Process Re-Engineering
 - Current Process Improvement Initiatives
- **MITRE / SEI Collaboration**
- **NAVAIR / MITRE / SEI Collaboration**
- **Summary**

OVERVIEW

- **NAVAIR Software Intensive Systems Overview**
 - ↳ Business Profile
 - 1999 Software Business Process Re-Engineering
 - Current Process Improvement Initiatives
- **MITRE / SEI Collaboration**
- **NAVAIR / MITRE / SEI Collaboration**
- **Summary**

MAJOR NAVAIR SITES



WEAPONS DIVISION, CHINA LAKE & PT MUGU, CA

Provides our forces with effective and affordable integrated warfare systems and life cycle support to ensure battlespace dominance.

<http://www.nawcwpns.navy.mil>



AIRCRAFT DIVISION, LAKEHURST, NJ

Provides aircraft launch and recovery expertise to the fleet.
<http://www.lakehurst.navy.mil>



AIRCRAFT DIVISION, PATUXENT RIVER, MD

Provides acquisition management, research and development capabilities, air and ground test and evaluation, aircraft logistics and maintenance management for Naval aviation.
<http://www.nawcad.navy.mil>

NAVAIR WEB SITE: <http://www.navair.navy.mil>



NAVAIR DEPOT, NORTH ISLAND, CA

Provides comprehensive quality aviation support to the nation's warfighters.

Aircraft: F/A-18 Hornet; E-2C Hawkeye; C-2 Greyhound; S-3 Viking; H-60 Seahawk
<http://www.nadepni.navy.mil>



TRAINING SYSTEMS DIVISION, ORLANDO, FL

Center for research, development, test and evaluation, acquisition and product support of training systems for the world.
<http://www.ntsc.navy.mil>



NAVAIR DEPOT, JACKSONVILLE, FL

Delivers high quality maintenance, engineering, logistics and support services to the Fleet.

Aircraft: P-3 Orion; EA-6B Prowler, F-14 Tomcat, F/A-18 Hornet; S-3 Viking; SH-60 Seahawk
<http://www.nadjx.navy.mil>



NAVAIR DEPOT, CHERRY POINT, NC

Delivers on time quality products and services for Naval aviation as service to the Fleet.

Aircraft: AV-8B, Harrier; H-53, Sea Stallion; C-130, Hercules; H-46, Sea Knight; V-22, Osprey; VH-3, Presidential Helicopter
<http://www.nadepcp.navy.mil>

NAVAIR PRODUCTS . . .

AIR ASW / ASUW



SEA BASED AIRCRAFT AND SYSTEMS

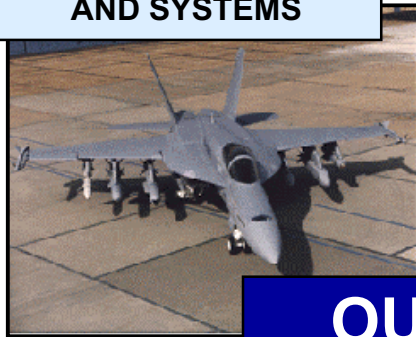

MARITIME WEAPONS



MARINE EXPEDITIONARY AVIATION SYSTEMS

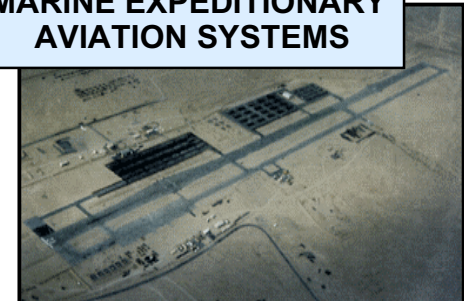

AIRCREW / MAINTENANCE TRAINING SYSTEMS



OUR CORE PROCESSES . . .

. . . WE EXECUTE (ON BEHALF OF THE USER)

ACQUISITION
MANAGEMENT

REPAIR /
MODIFICATION

TEST AND
EVALUATION

IN-SERVICE ENGINEERING
AND LOGISTICS SUPPORT

TECHNOLOGY, RESEARCH & DEVELOPMENT,
HARDWARE & SOFTWARE PRODUCTS

**. . . MORE THAN AIRCRAFT AND WEAPONS,
TOTAL SYSTEM CAPABILITY AND SUSTAINMENT**

Software Engineering Institute
Carnegie Mellon University

MITRE

NAVAIR

NAVAIR ASSOCIATED PEOs

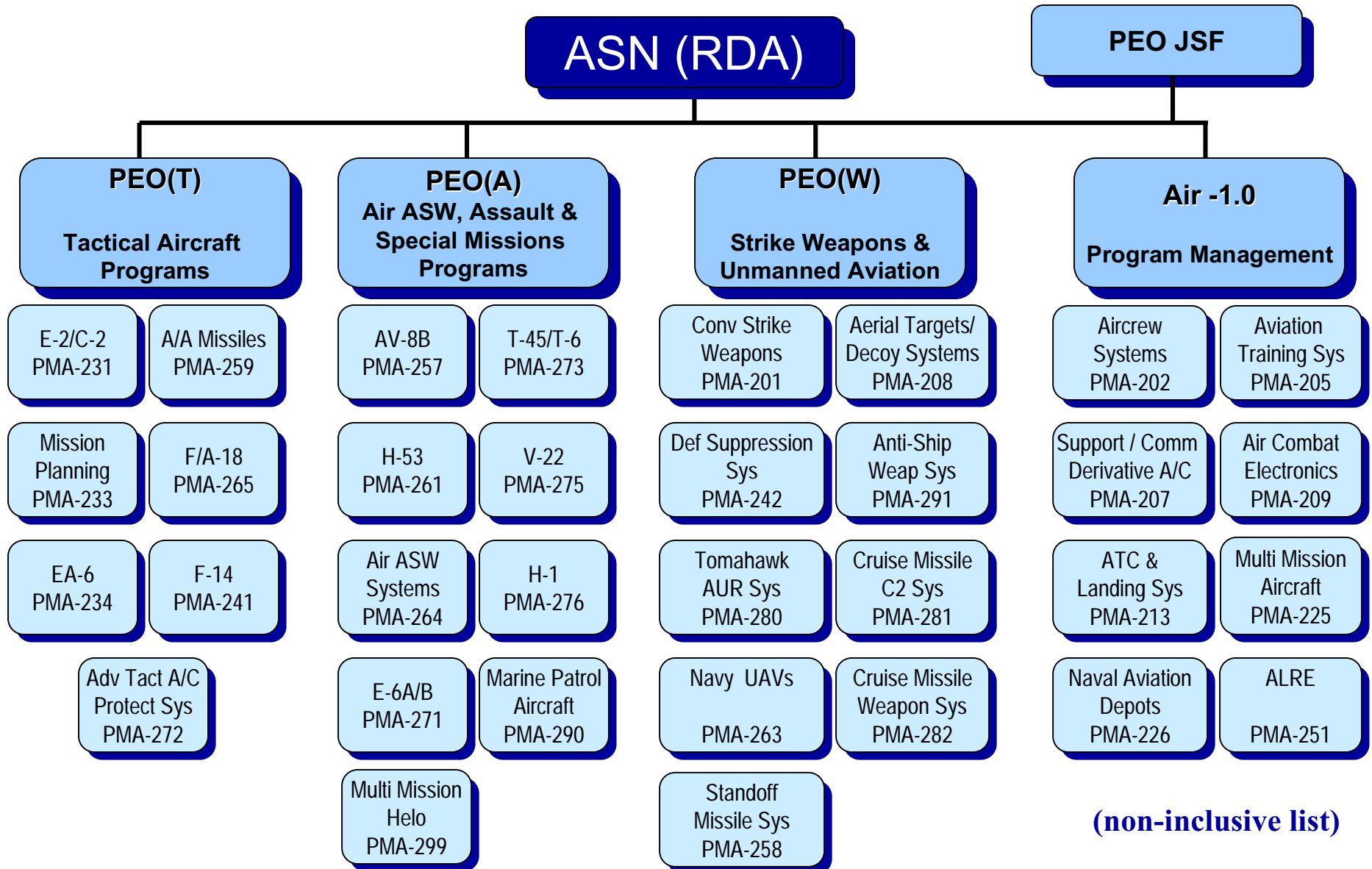

(non-inclusive list)

Software Engineering Institute
Carnegie Mellon University

MITRE

NAVAIR

NAVAIR Software Intensive Systems

- Software Maintenance Accomplished Via System Support Activities (SSAs)
 - Government and/or Contractor Maintenance
 - Funded Via Program Related Engineering
 - Primarily Supports Helo and Fixed Wing Aircraft
 - SLOC Counts for Both Development and Maintenance Efforts Available
- Does Not Include All Software Efforts:
 - Cruise Missile, Conventional Strike and Standoff Weapons
 - UAV Programs and Tactical Control System (TCS)
 - Range and Corporate Software

Estimate Over \$2B on Software Development and Related Activities Per Fiscal Year

Software Maintenance Activities... Government / Commercial SSAs

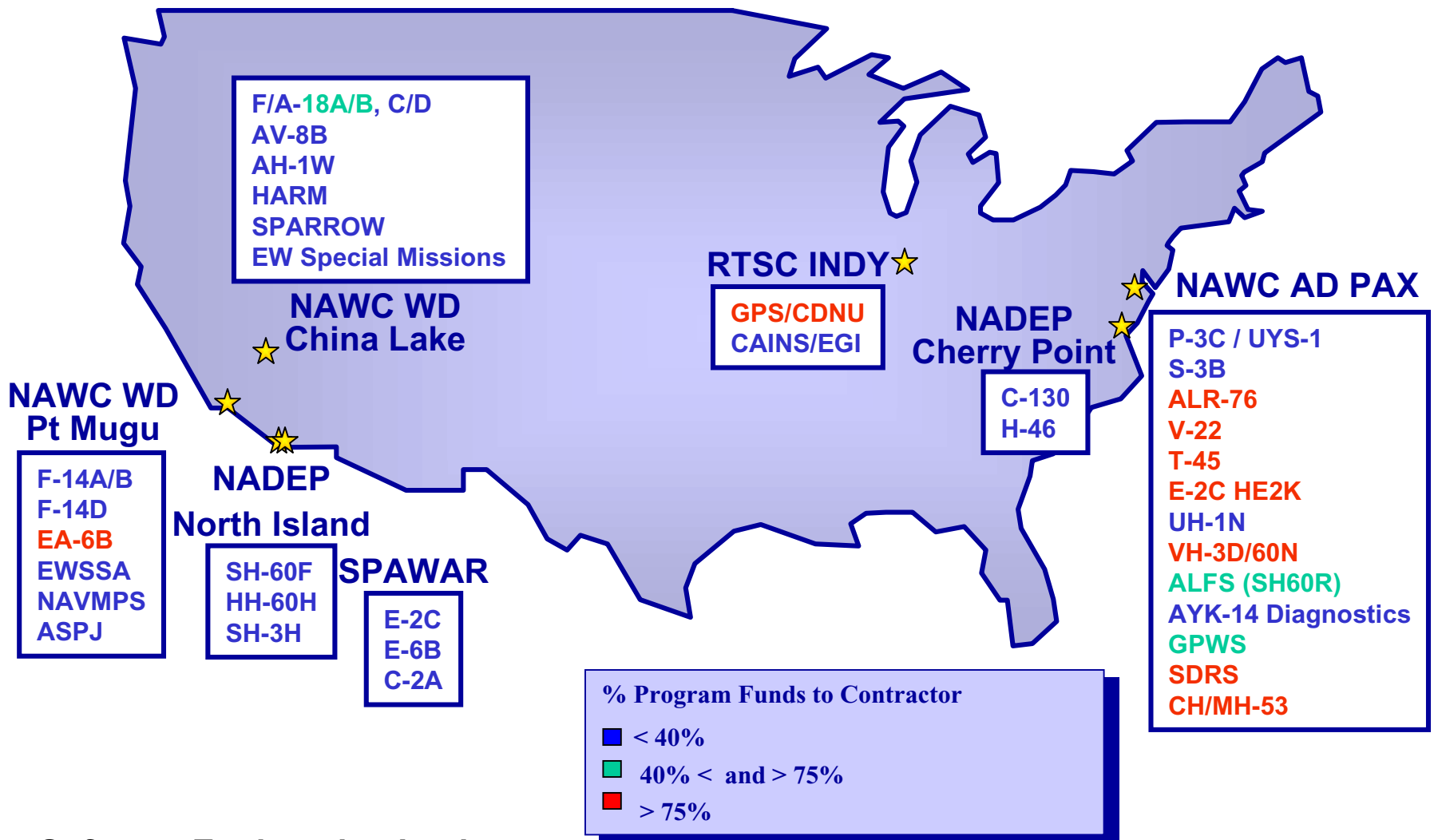

Software Engineering Institute
Carnegie Mellon University

MITRE

NAVAIR

NAVAIR System Support Activities

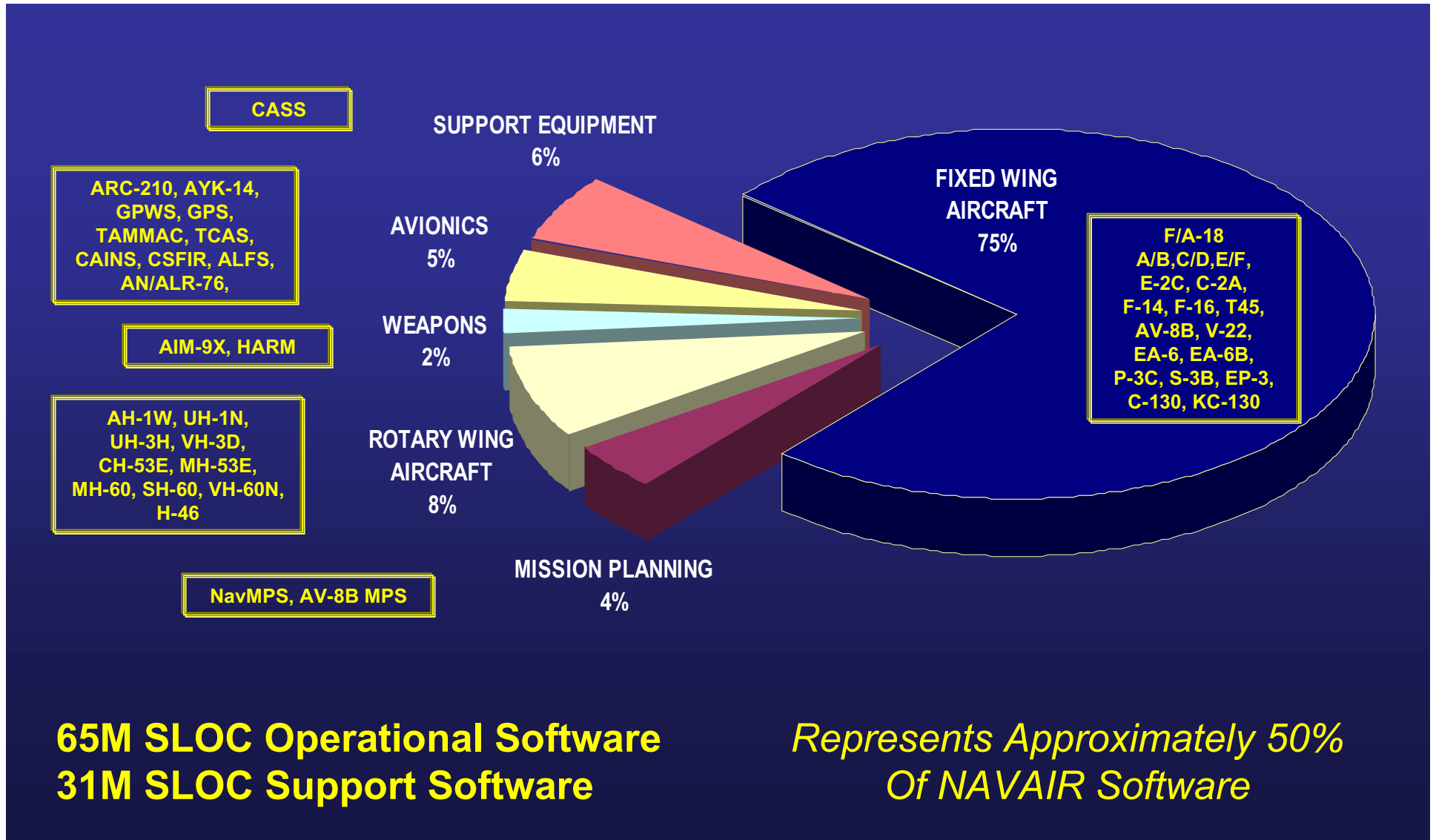

NAVAIR Software Growth

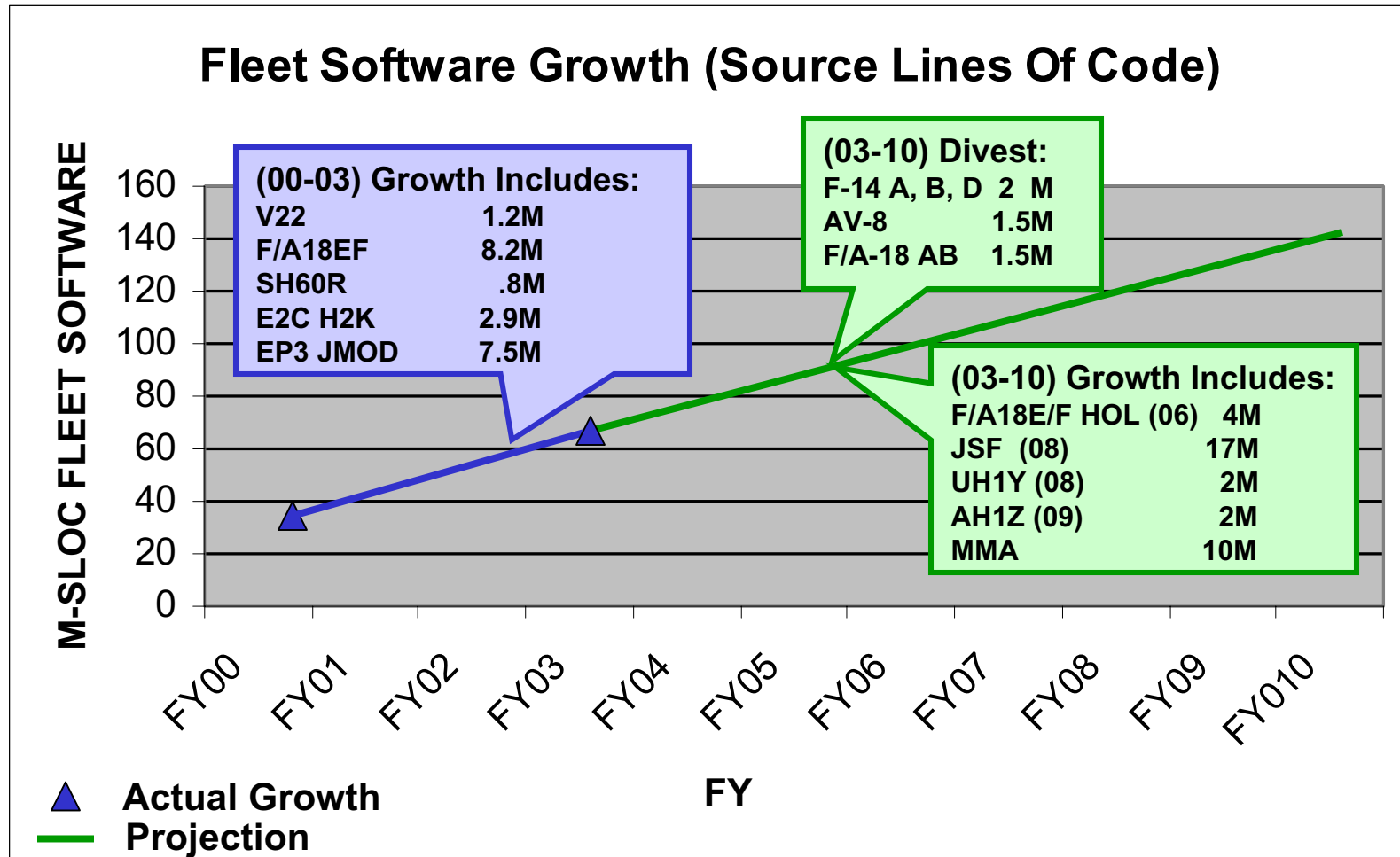

Typical Release Schedule and Size Trends

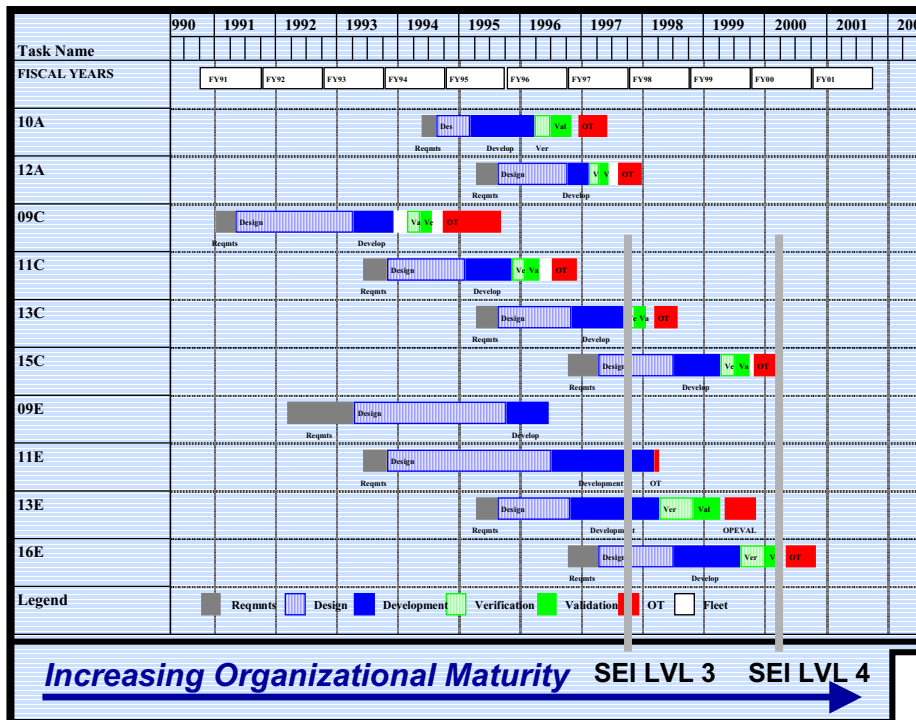

*Cycle Time Decreases
Or Remains Constant
For Each Variant... With
Increasing Upgrade Size*

*Size of Software Upgrades
Double Approximately
Every 24 Months*

Software Engineering Institute
Carnegie Mellon University

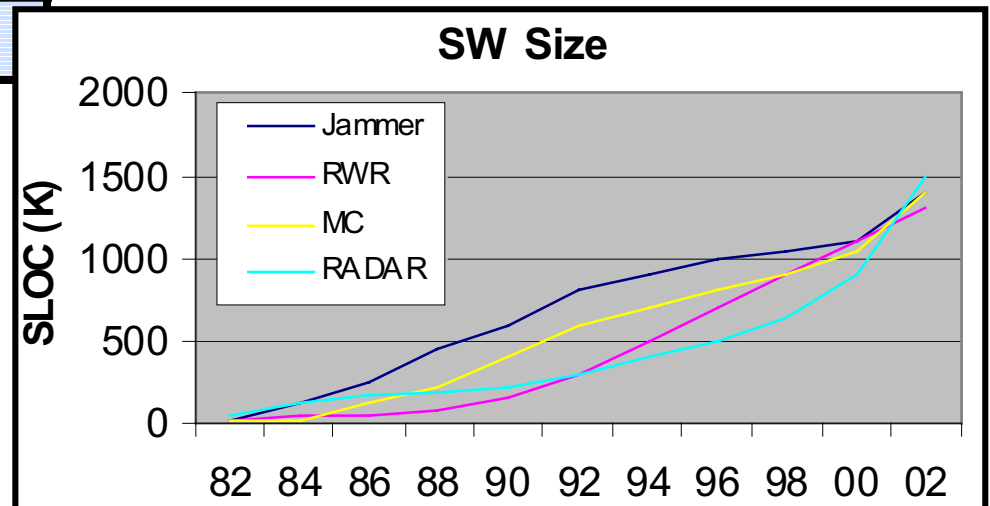

MITRE

NAVAIR

OVERVIEW

- **NAVAIR Software Intensive Systems Overview**
 - Business Profile
 - ↳ 1999 Software Business Process Re-Engineering
 - Current Process Improvement Initiatives
- **MITRE / SEI Collaboration**
- **NAVAIR / MITRE / SEI Collaboration**
- **Summary**

1999 Software BPR Premise and Charter

- In 5 Years NAVAIR Could Be Saving Approximately \$400 M Per Year in Software Costs If:
 - Modify the Organization
 - Make a Commitment to NAVAIR Personnel
 - Aggressively Incorporate Commercially Proven Processes

CHARTER

- Develop a **strategic** plan to **reduce software costs** (short and long term) and develop a government/industry mix, which defines TEAM **future role** in software development and support while maintaining customer satisfaction.
- Develop a **strategy** to position TEAM for a **smaller software market** (up to 50%) and optimize resource allocation for both development and in-service support.

1999 SW BPR Findings: Successful Software Development Organizations

- Utilize the Software Engineering Institute Capability Maturity Model[®] (SEI-CMM[®]).
- Are motivated to improve by Senior Management commitment and vision.
- Have an initial investment and reinvestment up to 5% of their S/W product cost in process improvement initiatives.
- Improve by utilizing corporate leadership teams (SEPG's, PAT's, and SEC's) to motivate and encourage the development of processes and procedures.
- Are integrating Systems Engineering and Software Development Engineering processes together.
- In a partnering arrangement, organizations with similar maturity levels work better together.

NAVAIR CORE SYSTEM SOFTWARE EXPERTISE



Software Engineering Institute
Carnegie Mellon University

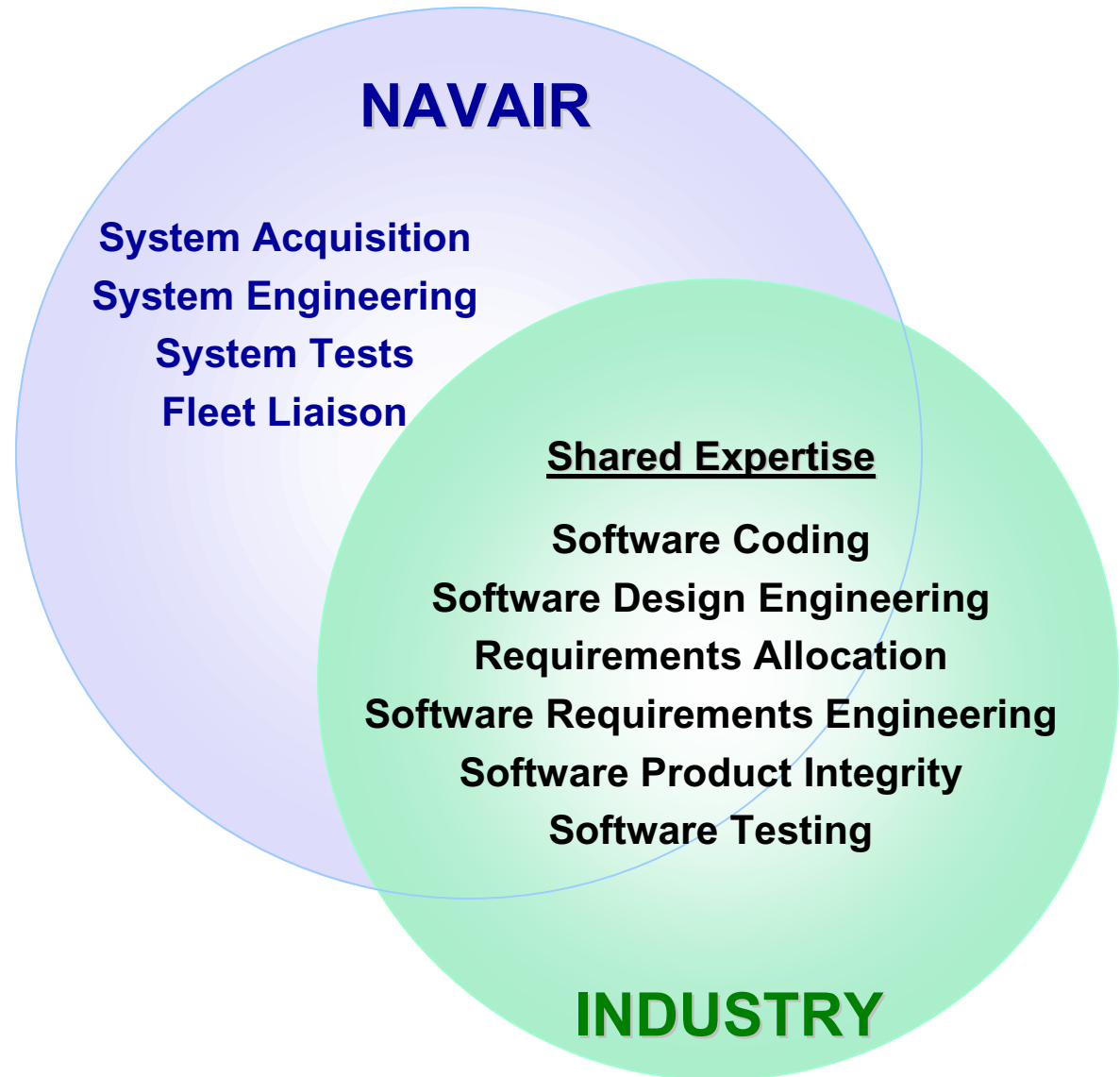

MITRE

NAVAIR

Software Strategic Plan

Strategy 1.0 Process Focus

Reduce the cost of software development and maintenance through the use of disciplined processes that are defined and implemented by both TEAM and contractor organizations.

Strategy 2.0 Organization/Capabilities Focus

Optimize and maintain the best skills mix within government and industry, develop and maintain the core system software expertise within TEAM, and eliminate redundancies among the various system software entities.

The system software organization will be flexible and responsive to the fluctuating marketplace.

Strategy 3.0 Workforce Focus

Corporate culture characterized by excellent communications, knowledgeable leadership, and commitment to employee professional and personal growth.

Empowered employees use policy, documented guidance, and defined TEAM processes supported by training, in the fulfillment of their job responsibilities.

Our TEAM places value on, and works to maintain, work force continuity in core capabilities.

OVERVIEW

- **NAVAIR Software Intensive Systems Overview**
 - Business Profile
 - 1999 Software Business Process Re-Engineering
 - ↳ Current Process Improvement Initiatives
- **MITRE / SEI Collaboration**
- **NAVAIR / MITRE / SEI Collaboration**
- **Summary**

Develop a Parallel Organization to Improve NAVAIR Software Performance

NAVAIRINST 5234.3
Establishment of System Leadership Council (SLC) and System Leadership Team (SLT)

Hierarchy

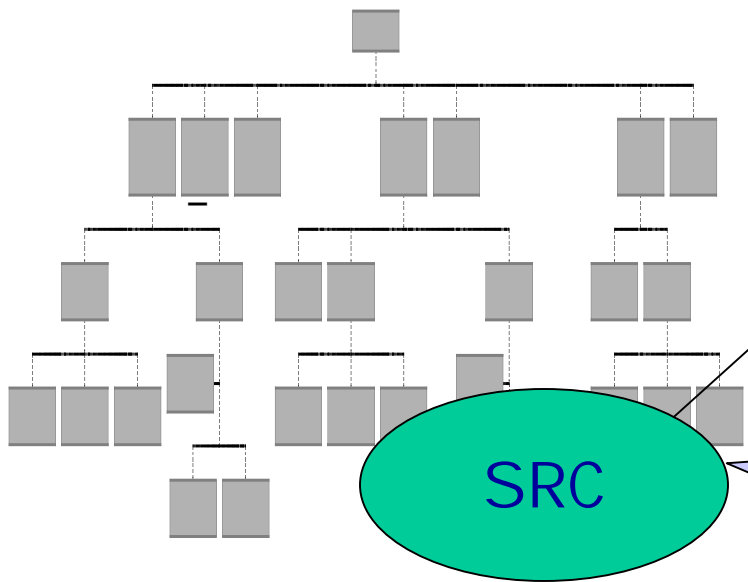

Software Engineering Institute
Carnegie Mellon University

Parallel Organization

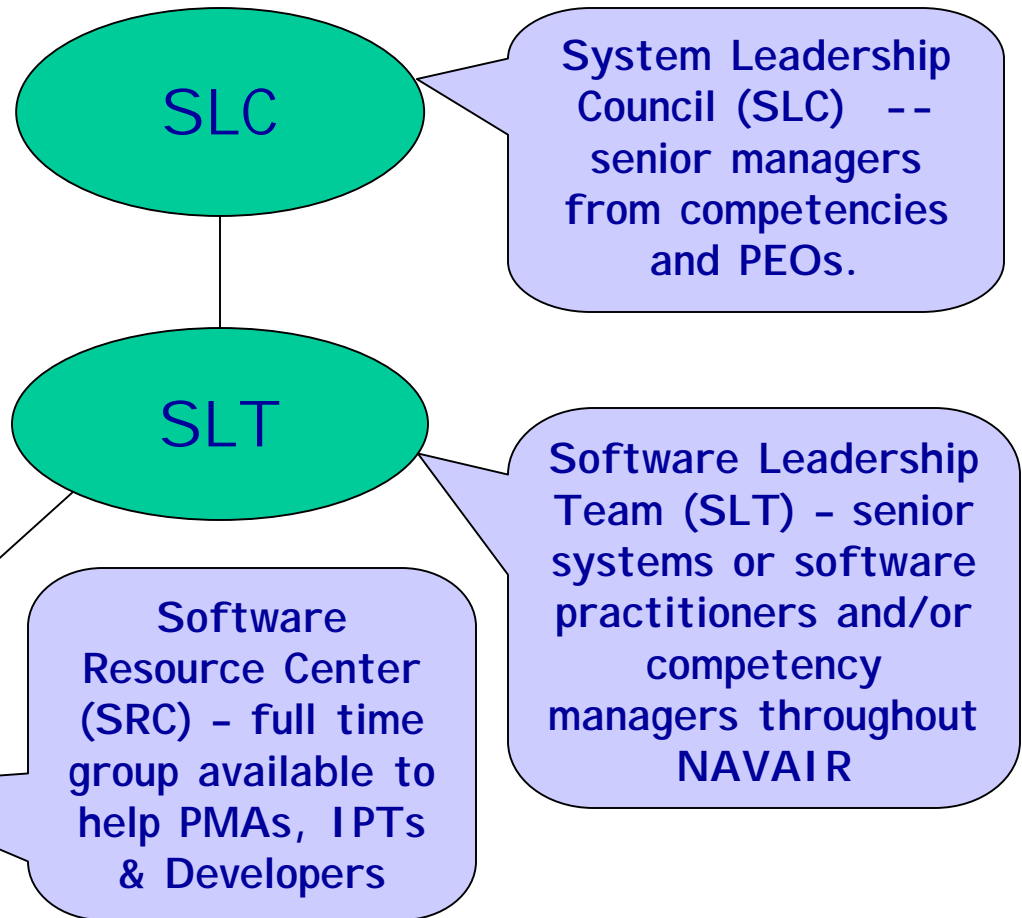

MITRE

NAVAIR

Current SLC / SLT Initiatives

- Improve NAVAIR Acquisition and Technical Management of Software Intensive Systems (SIS) for Both Contracted and In-house Developed Software
- Enhance and Improve NAVAIR Workforce for SIS
- Develop and Maintain Core System Software Expertise Within NAVAIR
- Increase Collaboration With Industry and Academia to Improve NAVAIR Software Performance
- Review Emerging Software Technologies to Establish How NAVAIR Will Be Doing Software in the Future (5 to 10 Years)

Current SRC Initiatives

- Support the implementation of strategies, goals and objectives to improve software system performance.
- Provide assistance in implementing NAVAIR policy related to software and systems engineering to programs and competencies.
- Develop relationships and form strategic partnerships with external software systems organization to enhance knowledge sharing.
- Coordinate and conduct SW Process Improvement Communities of Practice.
- Develop and conduct software systems related training.
- Develop and maintain the “lessons learned” and software information repository.
- Develop and maintain the software systems “Help Desk”.
- Develop, maintain, and improve the NAVAIR corporate software processes that are tailorable for use by program and competency teams.

SRC FACILITATION STRATEGIES



1. FACILITATE IMPLEMENTATION OF TEAM POLICIES AND PROCEDURES

2. VERTICAL COLLABORATION EXAMPLES – Relationship Manager (RM) Assigned by Site IPT Location

3 - HORIZONTAL COLLABORATION

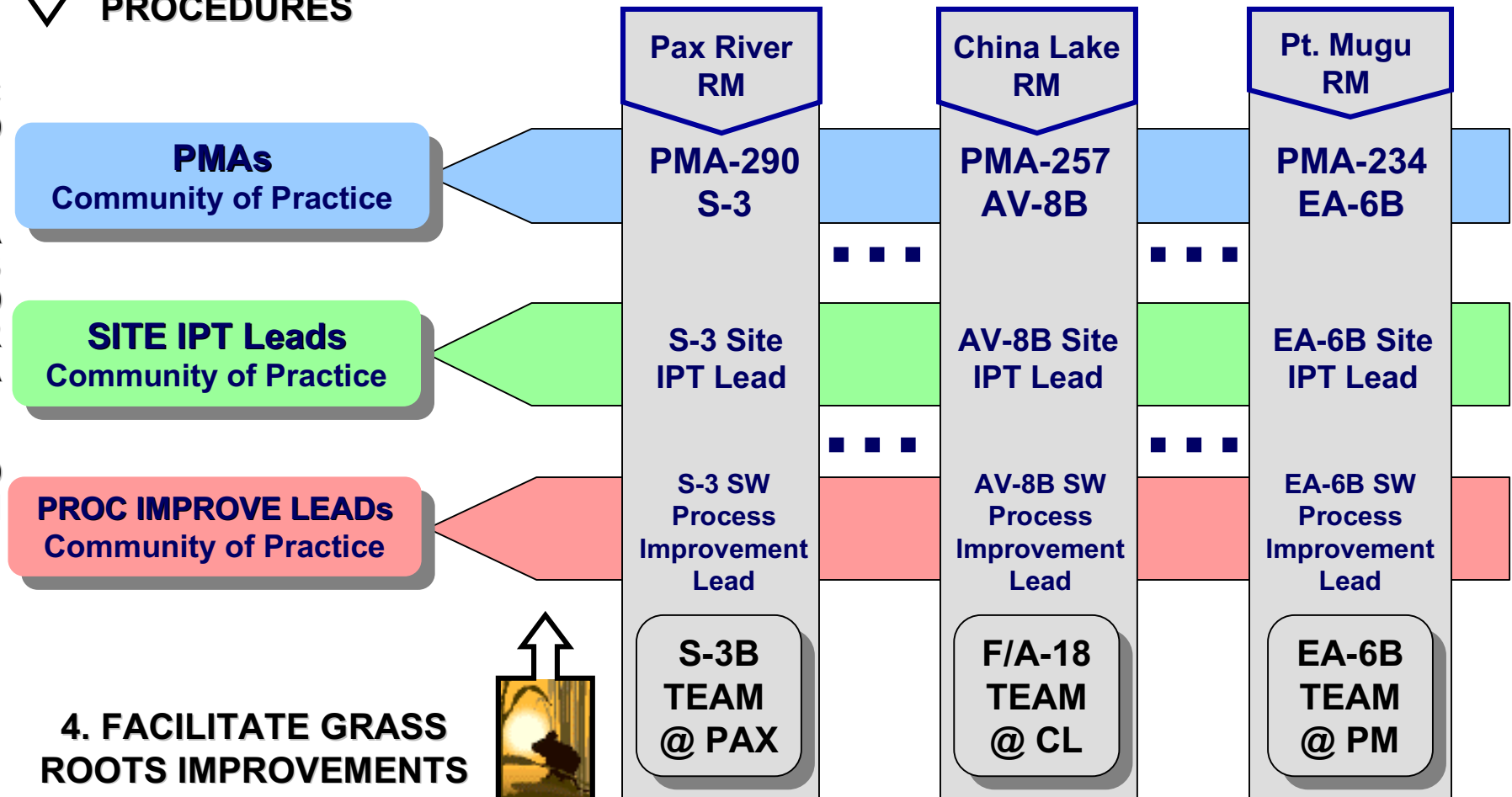

4. FACILITATE GRASS ROOTS IMPROVEMENTS



Software Engineering Institute
Carnegie Mellon University

MITRE

NAVAIR

People, Process, and Product Resource (P3R) and SRC Inter-Relationship

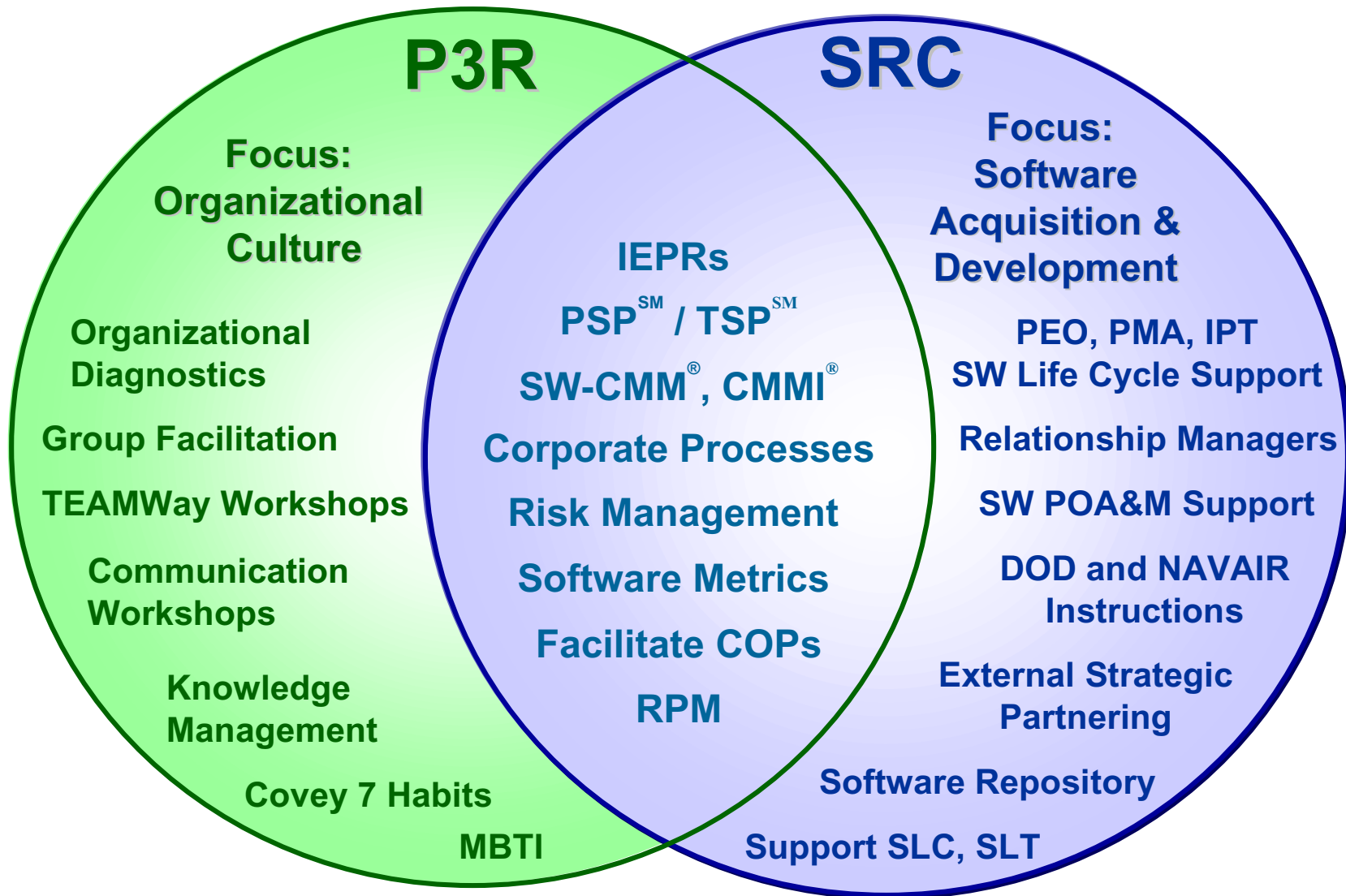

Software Engineering Institute
Carnegie Mellon University

MITRE

NAVAIR

CMM, TSP & PSP Relationship

CMM - Builds organizational capability

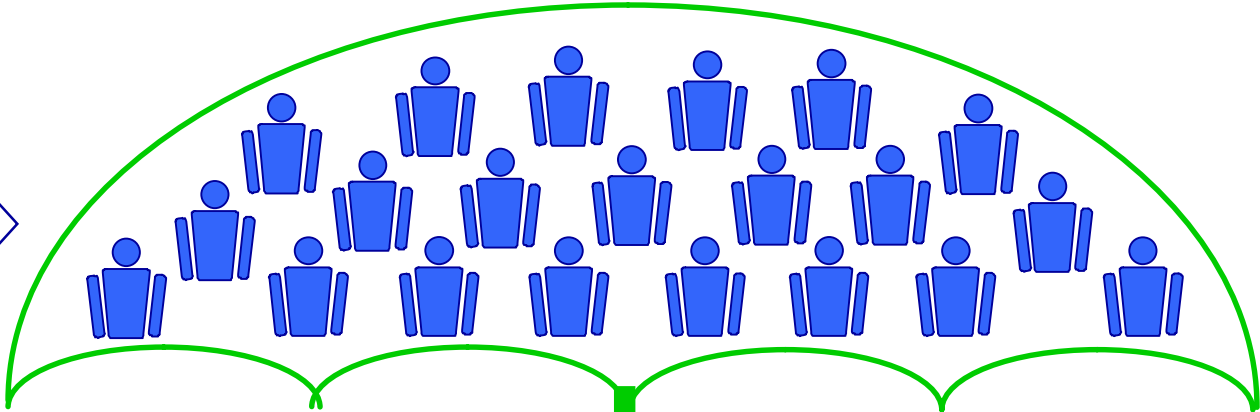

TSP - Builds quality products on cost and schedule

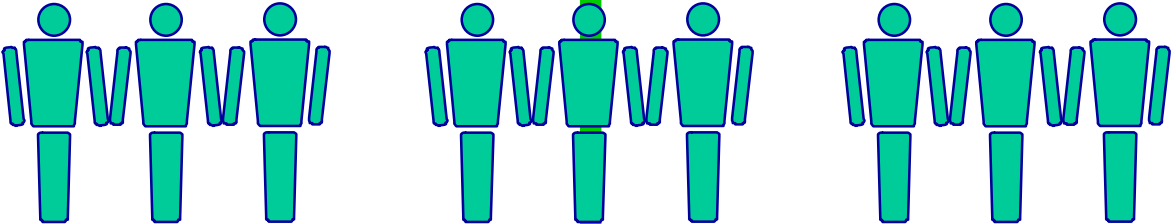

PSP - Builds individual skill and discipline

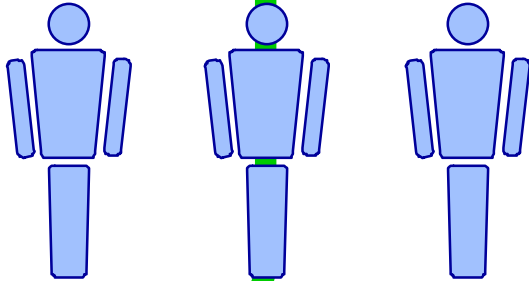

SW-CMM Journey

Military/Federal Organizations (2002 Data)

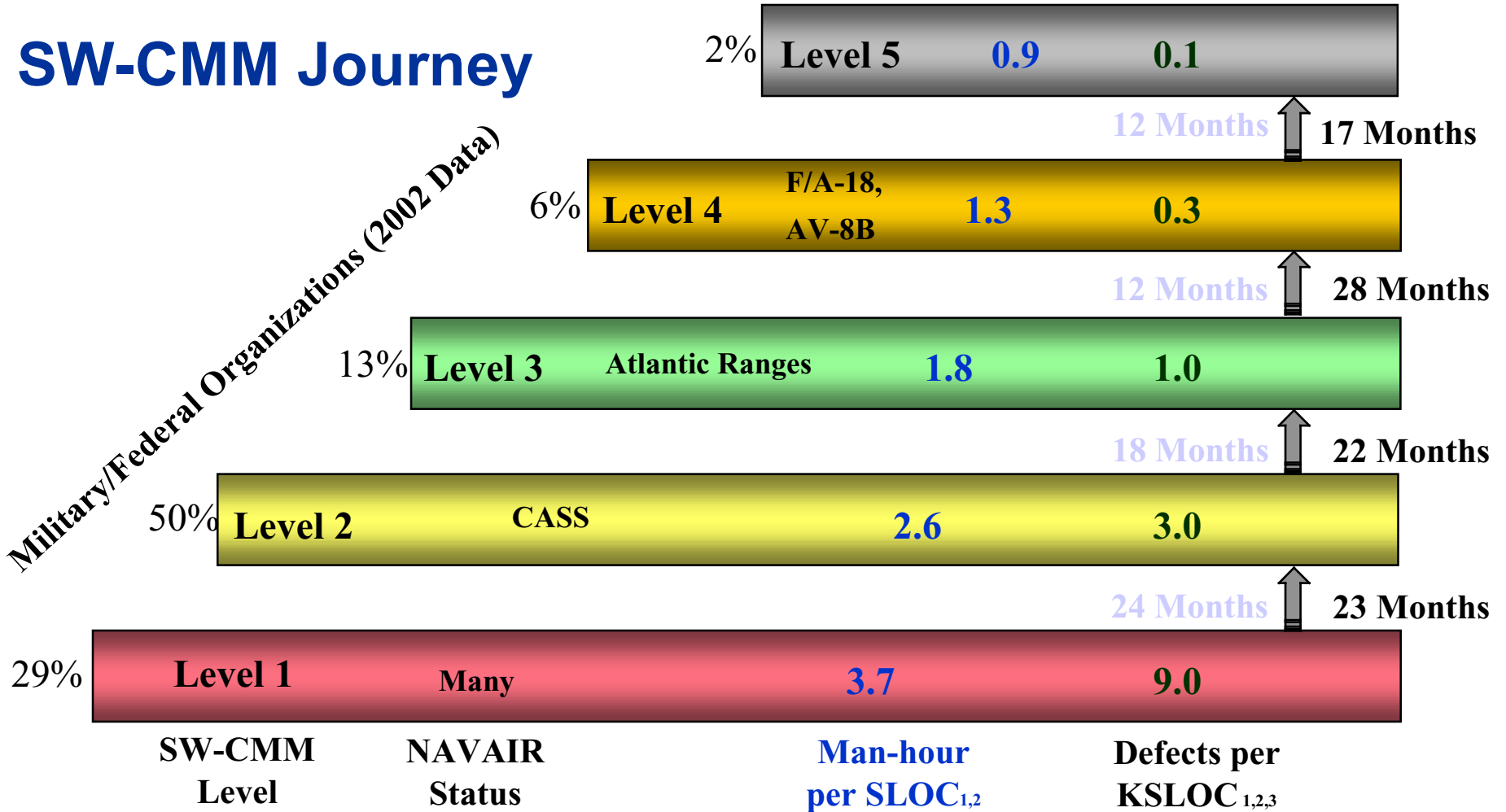

At NAVAIR... PSP/TSP is Accelerating Maturity Level Transition

Metric Sources:

1. 1994 Citibank Analysis
2. Applied Software Measurement, Capers Jones
3. Benchmarking F/A-18 Mission Computer Inspection 1998
4. 1995 ISD, Inc and Carnegie Mellon University adapted

**Software Engineering Institute
Carnegie Mellon University**

MITRE

NAVAIR

Rate of Programs Working Improvement Initiatives

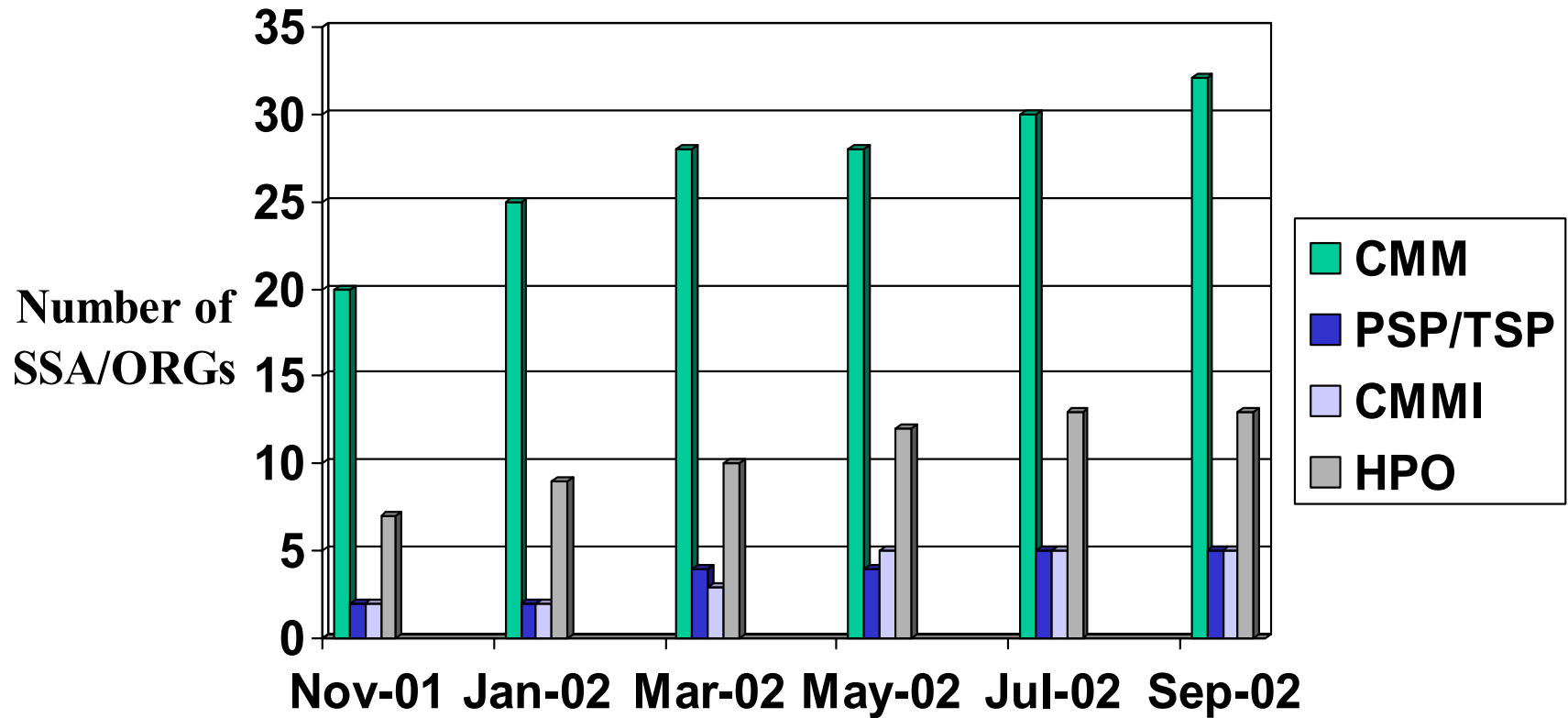

Software Engineering Institute
Carnegie Mellon University

MITRE

NAVAIR

NAVAIR Software Instructions

5234.1 Policy on Software Intensive Systems Contracting

- SW-CMM Level 3 (or Equivalent)
- Risk Management Plan

5234.2 Requirements on Process Improvement Actions

- POA&Ms For SW-CMM, CMMI, PSP/TSP Utilization

5234.4 Independent Expert Program Reviews

5234.5 Software Metrics

- Requirements, Capacity
- Size, Staffing, Schedule, Cost
- Quality, Maturity

OVERVIEW

- **NAVAIR Software Intensive Systems Overview**
 - Business Profile
 - 1999 Software Business Process Re-Engineering
 - Current Process Improvement Initiatives
- ⌘ **MITRE / SEI Collaboration**
- **NAVAIR / MITRE / SEI Collaboration**
- **Summary**

The SEI/MITRE Collaboration

- SEI and MITRE have signed an MOU to collaborate in support of the Navy implementation of CMMI-based improvement.
- We recognize the importance of introducing and reinforcing disciplined and rigorous software and system engineering practices to the acquisition of SIS and believe this approach will support NAVAIR objectives.
- This collaboration leverages our strengths
- Software engineering expertise
 - Domain related systems engineering expertise
 - Unbiased evaluation of existing practices
 - Unbiased recommendations for prioritized implementation
 - Lessons-learned from real-world situations
 - Acquisition Program Office Support

The Software Engineering Institute (SEI)

- DoD R&D laboratory FFRDC
- Situated as a college level unit at Carnegie Mellon University, Pittsburgh, PA
- Mission is to provide leadership in software engineering and to transition new software engineering technology
- Encouraged to support industry in precompetitive technology R&D and in technology transition activities



**Software Engineering Institute
Carnegie Mellon University**

MITRE

NAVAIR

The MITRE Corporation

- A not-for-profit corporation combining systems engineering and information technology to address issues of critical national importance.
- Operates three FFRDCs:
 - Systems engineering and integration work for Department of Defense C3I.
 - Systems research and development work for the FAA and other civil aviation authorities.
 - Strategic, technical and program management advice to the IRS and Treasury Department.

Federally Funded Research and Development Centers (FFRDC)

- Able to address complex technical problems of critical importance to sponsors with a breadth and depth of expertise beyond that available inside the government
- Access, beyond what is common to the normal contractual relationship, to Gov't and supplier data, including sensitive and proprietary data, and to employees and facilities
- Are required to conduct business in a manner befitting its special relationship with the Government
- Required to operate in the public interest with objectivity and independence
- Required to be free from organizational COI
- May not compete with the private sector

Benefits of Working with FFRDCs (SEI and MITRE are both FFRDCs)

- Public interest/not-for-profit; do not compete
- Long-term access and perspective not available to commercial contractors
- Unconstrained by product installed base
- Free of pressure to get product to market
- Able to address complex technical problems of critical importance to sponsors with a breadth and depth of expertise beyond that available inside the government
- Long-term involvement in reducing the risk in the acquisition of Software Intensive Systems

The Basis for the SEI/MITRE Collaboration

- Both SEI and MITRE have long-term involvement in development and evolution of CMMs and Systems Engineering
- SEI has developed CMMs for software, people, and software acquisition and has assisted in the development of CMMs for systems engineering and integrated product and process development.
- MITRE is the Systems Engineer for Major Modernization Efforts across DOD and has considerable C4ISR domain expertise
- Both SEI and MITRE have broad experience with documented success in working with DOD, other federal agencies, industry, and international customers

OVERVIEW

- **NAVAIR Software Intensive Systems**
 - Business Profile
 - 1999 Software Business Process Re-Engineering
 - Current Process Improvement Initiatives
- **MITRE / SEI Collaboration**
- **NAVAIR / MITRE / SEI Collaboration**
- **Summary**

The Purpose of the NMS Collaboration

- To reduce risk and enhance the effectiveness of NAVAIR in the development, acquisition, and maintenance of software.
- Transition technology to NAVAIR
 - System and Software Competencies
 - Program Offices, Program Support Activities
- Assist NAVAIR activities with process improvements and program management planning and implementation.
- Support initiatives of Systems Leadership Council (SLC) and provide semi-annual status reviews.
- Participate in the NAVAIR Communities of Practice (COP).

The Value of the NMS Collaboration

- Acquiring, modernizing, replacing, or maintaining complex software intensive systems requires disciplined and rigorous software engineering and systems engineering practices.
- The SEI - MITRE collaboration can augment NAVAIR SIS acquisitions with their ability to
 - Understand multiple systems, and multiple proprietary technologies, and how they fit together
 - Effectively address critical software-related aspects of complex systems
 - Be perceived as objective by both Government and industry
 - Access sensitive Government information and proprietary industry information

The Benefits of the NMS Collaboration

- Leverages MITRE / SEI Strengths to Meet NAVAIR Needs
 - Software Engineering
 - **SW-CMM, CMMI**
 - **PSP/TSP**
 - **Integrated System Acquisition Metrics (ISAM)**
 - C4ISR Systems Engineering
- Complements NAVAIR Organic Capabilities
 - Software Intensive Systems Acquisition Experience
 - Software Competency Organization
 - Software Resource Center

The Framework of the NMS Collaboration

- Coordinated and Open Communications
- Manage a diverse set of virtual resources to achieve objectives
- Review and assess progress... make adjustments as necessary
- Address cultural Issues
- Identify teambuilding opportunities

Potential for NMS Collaboration Support in NAVAIR

- Multi-Mission Maritime Aircraft (MMA)
- PMA-209 - Common Link Integration Processing/Tactical Data Link Common Software (CLIP/TDLCS)
- NAVAIR Software Support Activities
- P3R Team Support
 - Training & coaching (PSP/TSP, CMM/CMMI, TAP)
 - CMM/CMMI Implementation/Appraisals/Evaluations
 - IEPRs
 - Red and Blue Teams
 - Strategic Planning

OVERVIEW

- **NAVAIR Software Intensive Systems**
 - Business Profile
 - 1999 Software Business Process Re-Engineering
 - Current Process Improvement Initiatives
- **MITRE / SEI Collaboration**
- **NAVAIR / MITRE / SEI Collaboration**

⌚ **Summary**

The Way Ahead

- NAVAIR, MITRE, and SEI are partnered to reduce risk in the development of software intensive systems through
 - Process Improvement
 - Technology Transfer
 - Personal and Team Efficiency
 - Leveraged Capabilities
- See you next year with a progress report