

# CONSIDERATIONS OF ROD-PINCH DIODE OPERATION IN NEGATIVE POLARITY FOR RADIOGRAPHY\*

G. Cooperstein<sup>a</sup>, S.B. Swanekamp<sup>b</sup>, J.W. Schumer, P.F. Ottinger, and R.J. Comisso  
Plasma Physics Division, Naval Research Laboratory, Washington, DC 20375

## Abstract

Negative polarity diode geometries are investigated from 2 – 10 MV with 2D PIC simulations for application to radiography. Rod-pinch (RP) diodes with non-reentrant blunt tip anodes (anode does not pass through a cathode aperture) are investigated and compared to self-magnetically-pinched (SMP) diodes with similar geometries. At lower voltages, reentrant RP geometries are needed so that the space-charge-limited (SCL) current will exceed the critical current. Once self-pinching is achieved, the electron flow patterns in both types of diodes are similar, but it is speculated that RP diodes will maintain their small spot size for the duration of the pulse. At higher voltage, negative polarity non-reentrant RP designs can take advantage of smaller spot sizes, larger forward-going dose, reduced ion losses, and resistance to gap closure by decoupling the spot from the diode impedance. Reduced ion currents increase the electron current on the high-Z target which could increase the dose by about 40% compared to a positive polarity RP geometry.

## I. INTRODUCTION

The rod-pinch (RP) diode has been extensively studied as a radiographic source on positive polarity generators from 0.5 to 6 MV.[1-3] Positive polarity operation optimizes electron flow to the anode rod by minimizing anode emission surfaces that can lead to extraneous electron losses. Below 4 MV, the electron angular distribution at the rod tip allows for efficient radiation production in the forward direction (0°). The recent experiments on Asterix at 4 – 6 MV[3] and related numerical simulations[4] suggest that 1.4 - 2 times more radiation is produced in the backwards direction because most of the electrons approach the tapered anode at angles close to 180°. At higher voltages, the asymmetry in electron angles-of-incidence is more strongly coupled to the radiation distribution, thus the desire for higher x-ray yield in the forward direction will require more difficult negative polarity geometries for voltages above 4 MV. Recent experiments at AWE have successfully investigated reentrant negative-polarity RP geometries below 3 MV.[5]

In this paper, charged-particle flows in negative polarity diode geometries are investigated from 2 – 10 MV using the MAGIC 2D PIC code[6]. The cathode used throughout this paper consists of a hollow cylinder with a 4-mm outer radius,  $R_C$ , and a 1-mm inner radius. The tip of the cathode was rounded as shown in Figs. 3-6. This cathode was chosen to be similar to that used on recent SMP diode experiments at AWE.[7] The anode geometries include blunt-tip anodes that are non-reentrant. At lower voltages, the negative-polarity RP diode requires reentrant geometries so that the SCL current will exceed the critical current. At higher voltages, where pinching occurs, particular attention must be paid to minimizing stray cathode emission and eliminating low-Z ions from anode surfaces inadvertently exposed to these stray electrons. In addition to the non-reentrant rod-pinch geometries, self-magnetically pinched (SMP) diodes with planar anodes are also considered as a candidate for negative polarity radiography sources above 4 MV.

Coupled PIC-Monte-Carlo simulations of a positive polarity, 2-mm diameter, blunt reentrant anode using the LSP code[8] suggest that the dose at 10 MV near 180° at a distance of 1 m from the diode from a 2-mm diameter tungsten rod is about 800 rad-LiF in a 50-ns FWHM radiation pulse width and a diode impedance of 50  $\Omega$ . [4] The negative-polarity geometries studied in this paper reduce the ion current fraction and are more amenable to reducing photon self-absorption in the rod. Therefore, it is believed that the forward-directed dose in negative polarity will be higher than the positive polarity results. Future experiments and LSP simulations are needed to verify this prediction.

## II. DIODE GEOMETRIES

It is well known that self-pinched electron-beam diodes, either conventional planar SMP diodes[9] or RP diodes[1], operate at a self-magnetically-limited total current (ions plus electrons) called the critical current. For a planar SMP diode, illustrated in Fig. 1a, the critical current is given by,  $I_{crit}(A) \cong \alpha 8500 (\gamma^2 - 1)^{1/2} (R_C/D)$  where  $\gamma$  is the relativistic factor,  $R_C$  is the cathode radius and  $D$  is the anode-cathode (A-K) gap spacing. For a positive-polarity, reentrant RP diode, illustrated in

\* Work supported by the US DOE through SNL, LANL, and LLNL

<sup>a</sup> email:cooperstein@nrl.navy.mil

<sup>b</sup> Titan-JAYCOR Division, McLean, VA 22101

# Report Documentation Page

*Form Approved*  
*OMB No. 0704-0188*

Public reporting burden for the collection of information is estimated to average 1 hour per response, including the time for reviewing instructions, searching existing data sources, gathering and maintaining the data needed, and completing and reviewing the collection of information. Send comments regarding this burden estimate or any other aspect of this collection of information, including suggestions for reducing this burden, to Washington Headquarters Services, Directorate for Information Operations and Reports, 1215 Jefferson Davis Highway, Suite 1204, Arlington VA 22202-4302. Respondents should be aware that notwithstanding any other provision of law, no person shall be subject to a penalty for failing to comply with a collection of information if it does not display a currently valid OMB control number.

1. REPORT DATE <b>JUN 2003</b>	2. REPORT TYPE <b>N/A</b>	3. DATES COVERED <b>-</b>	
4. TITLE AND SUBTITLE <b>Considerations Of Rod-Pinch Diode Operation In Negative Polarity For Radiography</b>		5a. CONTRACT NUMBER	
		5b. GRANT NUMBER	
		5c. PROGRAM ELEMENT NUMBER	
6. AUTHOR(S)		5d. PROJECT NUMBER	
		5e. TASK NUMBER	
		5f. WORK UNIT NUMBER	
7. PERFORMING ORGANIZATION NAME(S) AND ADDRESS(ES) <b>Plasma Physics Division, Naval Research Laboratory, Washington, DC 20375</b>		8. PERFORMING ORGANIZATION REPORT NUMBER	
9. SPONSORING/MONITORING AGENCY NAME(S) AND ADDRESS(ES)		10. SPONSOR/MONITOR'S ACRONYM(S)	
		11. SPONSOR/MONITOR'S REPORT NUMBER(S)	
12. DISTRIBUTION/AVAILABILITY STATEMENT <b>Approved for public release, distribution unlimited</b>			
13. SUPPLEMENTARY NOTES <b>See also ADM002371. 2013 IEEE Pulsed Power Conference, Digest of Technical Papers 1976-2013, and Abstracts of the 2013 IEEE International Conference on Plasma Science. IEEE International Pulsed Power Conference (19th). Held in San Francisco, CA on 16-21 June 2013. U.S. Government or Federal Purpose Rights License, The original document contains color images.</b>			
14. ABSTRACT <b>Negative polarity diode geometries are investigated from 2 10 MV with 2D PIC simulations for application to radiography. Rod-pinch (RP) diodes with non-reentrant blunt tip anodes (anode does not pass through a cathode aperture) are investigated and compared to self-magnetically-pinched (SMP) diodes with similar geometries. At lower voltages, reentrant RP geometries are needed so that the space-charge-limited (SCL) current will exceed the critical current. Once self-pinching is achieved, the electron flow patterns in both types of diodes are similar, but it is speculated that RP diodes will maintain their small spot size for the duration of the pulse. At higher voltage, negative polarity non-reentrant RP designs can take advantage of smaller spot sizes, larger forward-going dose, reduced ion losses, and resistance to gap closure by decoupling the spot from the diode impedance. Reduced ion currents increase the electron current on the high-Z target which could increase the dose by about 40% compared to a positive polarity RP geometry.</b>			
15. SUBJECT TERMS			
16. SECURITY CLASSIFICATION OF:			17. LIMITATION OF ABSTRACT
a. REPORT <b>unclassified</b>	b. ABSTRACT <b>unclassified</b>	c. THIS PAGE <b>unclassified</b>	<b>SAR</b>
			18. NUMBER OF PAGES <b>4</b>
			19a. NAME OF RESPONSIBLE PERSON

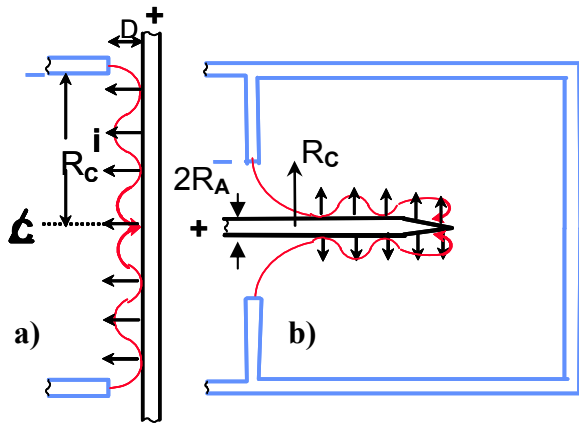

**Figure 1.** Schematic of a) SMP and b) RP diodes.

Fig. 1b, the critical current is,  $I_{crit} (A) \cong \alpha 8500 (\gamma^2 - 1)^{1/2} / \ln(R_c/R_A)$  where  $R_A$  is the anode radius. The scaling factor  $\alpha$  is needed to obtain agreement between PIC simulations and derived analytical critical current formulas. Without ions, this scale factor  $\alpha$  is found to be about 1.5 for both kinds of self-pinched diodes. The presence of anode ions alters the simulation results differently for SMP diodes and RP diodes. For SMP diodes with ions,  $\alpha \cong 2.1$ , independent of  $R_c/D$ . For RP diodes with ions,  $\alpha \cong 2.1$  for  $R_c/R_A \cong 1$  and  $\alpha \cong 2.6$  for  $R_c/R_A \cong 16$ .

A negative polarity, non-reentrant RP diode is illustrated in Fig. 2. If the anode is reentrant, then the critical current is expected to be the same as is discussed above for Fig. 1b. For the non-reentrant geometry, the situation is clearly more complicated with the A-K gap spacing,  $D$ , being an additional parameter. A phenomenological model for  $I_{crit}$  is discussed in the next section. Clearly, it is more difficult to draw enough SCL current at lower voltages to achieve critical current. Also, the SCL current for a reentrant geometry at lower voltages can be increased by increasing the cathode thickness. Thus, these non-reentrant RP diode geometries are more suited to higher voltage where pinching can be more easily achieved. One advantage of non-reentrant RP geometries is that high-atomic-number (high-Z) material

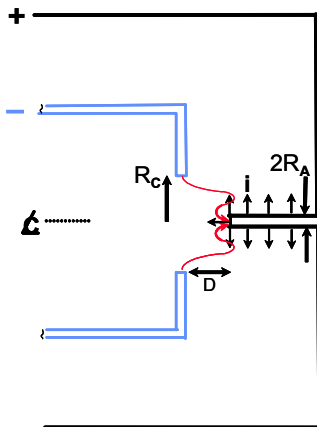

**Figure 2.** Schematic of negative polarity, non-reentrant RP diode.

is needed only at the tip of the rod for a length comparable to the electron range. The rest of the rod can be either hollow or low-Z material so as to minimize the absorption of the forward produced x-rays. Alternatively, the rest of the rod could be bent out of the way as done in recent AWE experiments.[5, 10]

### III. RESULTS AND DISCUSSION

A large number of PIC simulations were run using the MAGIC 2D code to investigate the SMP diode and a variant where the large diameter flat anode is replaced with a small 2-mm diameter rod. This small diameter rod converts the SMP diode into a negative-polarity non-reentrant RP diode. Simulations were run with electrons only, and with electrons and protons from the anode. They were run to equilibrium at 2 MV and 10 MV, or with a slowly varying voltage from 2 to 10 MV. The four geometries illustrated in Figures 3a, 3c, 5a and 5c are typical of all the geometries investigated.

In the SMP diode simulations, the anodes had a 10-mm radius,  $R_A$ , which simulated a flat anode plane. In the RP diode simulations, the anode radius was 1 mm. Electron emission in the simulations was enabled from both the rounded tip and the inner and outer surfaces of the cylinder 7-mm upstream from the tip. Very little effect on the diode current or flow patterns was obtained when the cathode's emitting area included just the rounded tip. Proton emission from the anode was enabled only from regions of the anode where electrons strike the surface.

The SMP diode simulations for 5- and 10-mm A-K gaps,  $D$ , are shown in Figures 3 and 4 and RP diode simulations for 3- and 5-mm axial A-K gaps are shown in Figures 5 and 6. All the figures show current flow contours where the separation between contours is 15 kA except in Figures 4b and 4c where it is 10 kA.

Figures 3 and 4 offer a dramatic demonstration that ions are needed for strong pinching. Without ions and for  $D = 5$  mm, the electron flow in the SMP diode self-pinches to only  $1/2$  the cathode radius at 10 MV (See Fig. 3b). For  $D = 10$  mm, the electron flow self-pinches to the cathode outer radius at 10 MV ( $\sim 75 \Omega$ ) (See Fig. 3d). As soon as ions are allowed, Fig. 4, relatively strong self-pinching is observed for voltages above 2 MV and  $D = 10$  mm ( $\sim 53 \Omega$ ) (See Fig. 4c).

Similar behavior is also observed in the electron flow patterns from negative-polarity, non-reentrant RP diodes shown in Figs. 5 and 6. The main difference is that a higher voltage is required to obtain even a moderate degree of self-pinching without ions. This is seen in Fig. 5b where electrons approach the anode tip but do not hit the blunt end without ions for 10 MV and  $D = 3$  mm ( $\sim 59 \Omega$ ). For  $D = 5$  mm, electrons only get to within a few mm of the anode tip at 10 MV ( $\sim 78 \Omega$ ) without ions (See Fig. 5d). Even with ions, Fig. 6, strong self-pinching does not occur until 4 MV for  $D = 3$  mm ( $\sim 40 \Omega$ ) and 6 MV for  $D = 5$  mm ( $\sim 50 \Omega$ ), both not shown. This is because there is not enough SCL current to drive the

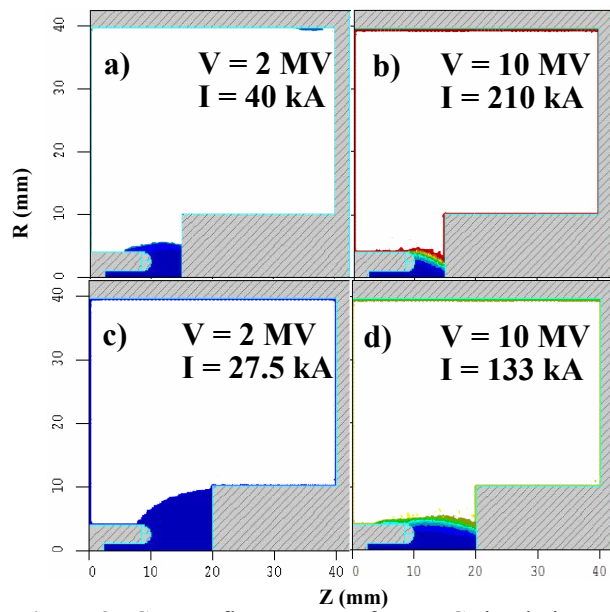

**Figure 3.** Current flow patterns from PIC simulations of SMP diode without ions. In a) and b),  $D = 5$  mm; in c) and d)  $D = 10$  mm.

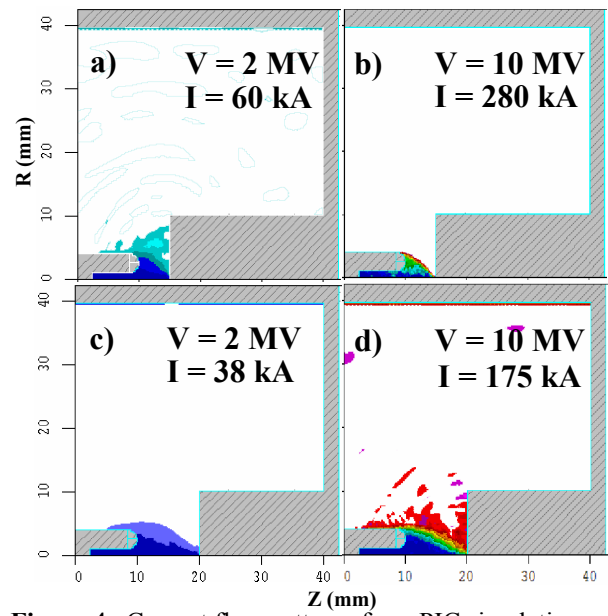

**Figure 4.** Current flow patterns from PIC simulations of SMP diode with ions. In a) and b),  $D = 5$  mm; in c) and d)  $D = 10$  mm.

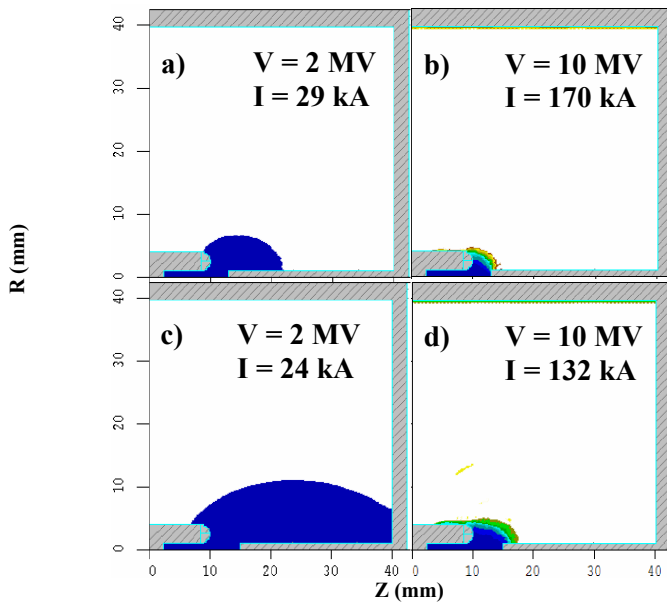

**Figure 5.** Current flow patterns from PIC simulations of RP diode without ions. In a) and b),  $D = 3$  mm; in c) and d)  $D = 5$  mm.

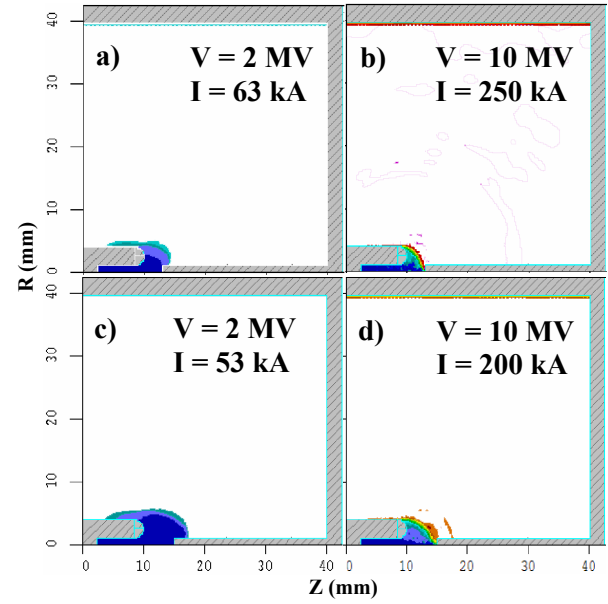

**Figure 6.** Current flow patterns from PIC simulations of RP diode with ions. In a) and b),  $D = 3$  mm; in c) and d)  $D = 5$  mm.

diode into the pinched phase. However, at 10 MV both the  $D = 3$  mm ( $\sim 40 \Omega$ ) (Fig 6b) and  $D = 5$  mm ( $\sim 50 \Omega$ ) (Fig. 6d) non-reentrant RP geometries are strongly self-pinched with nearly all the current peaking on the center of the blunt anode tip.

It is illustrative to compare the SMP and RP diodes with ions at 10 MV for the same 5-mm AK gap spacings (Figs. 4b and 6d respectively). Except for the lower impedance of the SMP diode,  $36 \Omega$  compared to  $50 \Omega$  for the RP diode, their behavior is remarkably similar once self-pinching is achieved. They both appear to form a

sub-mm radius pinch at the center of the anode with incident electron angles estimated from PIC simulations to be less than 25 degrees. In these cases, the percentage of total current lost to protons is 22% and 17% for the SMP and RP diodes, respectively. For comparison, the proton current fraction from a reentrant RP diode at 10 MV is estimated to be 45%.[4] Therefore, the electron current on the high-Z target increases significantly for the negative polarity geometries and could increase the dose by about 40%. Heating the anode prior to the shot could further increase the electron current by eliminating the source of the low-Z ions.[11]

With these similarities, why bother with the more difficult RP diode? It is speculated that time-dependent azimuthal asymmetries will cause the spot to wander in the SMP diode leading to larger time-integrated spot sizes than predicted with the 2D PIC code. On the other hand, once the pinch is formed on the blunt tip of the RP diode, the high self-magnetic field caused by the anode return current should hold the electron beam in place. This high field might capture more of the current in the tight pinch and lead to smaller electron angles of incidence for the RP diode, thus producing more x-rays in the forward direction than the SMP diode with similar voltage and current. Combining the two diodes by adding a small diameter rod on the axis of the SMP diode might allow pinching at low voltage while maintaining the small spot size. All this must be verified by experiments benchmarked against numerical simulation.

Table 1 summarizes the PIC data from SMP and RP diodes data and calculates an effective alpha factor ( $\alpha_{\text{eff}}$ ) for each of the geometries presented from their simulated currents in Figures 1 - 4. For the SMP diodes, this factor is calculated assuming the standard critical current formula for planar SMP diodes discussed earlier where  $\alpha_{\text{eff}}$  is the multiplier needed to make this current agree with the PIC simulations. The RP diode is a little more complicated because the critical current formula for cylindrical geometry discussed earlier only uses the cathode and anode radii,  $R_C$  and  $R_A$ , and does not consider the axial A-K gap spacing,  $D$ , for a non-reentrant geometry. We have chosen to phenomenologically modify this formula by using an effective cathode radius,  $R_{C\text{eff}}$ , which is the diagonal distance between the outer edge of the cathode and the center of the anode. Thus  $R_{C\text{eff}} = (R_C^2 + D^2)^{1/2}$ .

From Table 1, it can be seen that the SMP diode behaves as expected at 10 MV for  $D = 5$  mm.  $\alpha \sim 2$  with

**Table 1.** The last two columns contain  $\alpha_{\text{eff}}$  for the PIC simulations in Figures 3 - 6.

	$R_C$ (mm)	$D$ (mm)	$R_A$ (mm)	$\alpha_{\text{eff}}$	
				2MV	10MV
SMP no ions	4	5	10	1.22	1.50
	4	10	10	1.68	1.90
SMP ions	4	5	10	1.83	2.00
	4	10	10	2.32	2.50
RP no ions	4	3	1	1.14	1.57
	4	5	1	1.09	1.40
RP ions	4	3	1	2.48	2.30
	4	5	1	2.41	2.13

ions and  $\sim 1.5$  without ions. When  $D$  is 10 mm,  $\alpha$  is higher. This may be expected because the critical current formula is derived for large aspect ratio but here  $R_C/D = 0.8$  for  $D = 5$  mm and 0.4 for  $D = 10$  mm. At the smaller aspect ratio, more current is required to pinch the electron beam. The lower 2 MV SMP geometries are weakly pinched and thus expected to have lower  $\alpha$  factors. From Table 1, it can be seen that the RP diode also behaves as expected (with this model) at 10 MV for  $D = 3$  and 5 mm. Using  $R_{C\text{eff}}$ , theory predicts  $\alpha$  factors of about 2.3 with ions and about 1.5 without ions [1].

## V. REFERENCES

- [1] G. Cooperstein, J.R. Boller, R.J. Comisso, D.D. Hinshelwood, D. Mosher, P.F. Ottinger, J.W. Schumer, S.J. Stephanakis, S.B. Swanekamp, B.V. Weber, and F.C. Young, "Theoretical modeling and experimental characterization of a rod-pinch diode," *Phys. Plasmas*, **8**, 4618-4636, 2001.
- [2] R.J. Comisso, G. Cooperstein, D.D. Hinshelwood, D. Mosher, P.F. Ottinger, S.J. Stephanakis, B.V. Weber, and F.C. Young, "Experimental evaluation of a megavolt rod-pinch diode as a radiography source," *IEEE Trans. Plasma Sci.* **30**, 338-351, 2002.
- [3] R.J. Comisso, et al., "Overview of the 6-MV, rod-pinch experiment on Asterix," these proceedings.
- [4] S.B. Swanekamp, et al., "Angular dose variations from 4-6 MV rod-pinch experiments on the Asterix pulsed-power generator," these proceedings.
- [5] J.R. Threadgold, A.G. Pearce, M.A. Sinclair, and I. Crotch, "Further work on the implementation of rod pinch diodes on negative polarity pulse power drivers," *Proc. 14th International Conference on High-Power Particle Beams* (Albuquerque, 2002), pp. 159-162.
- [6] B. Goplen, et al., "User Configurable MAGIC for Electromagnetic PIC Calculations", *Comput. Phys. Commun.*, Vol. 87, **54**, May 1995, pp. 54-86.
- [7] I. Crotch, J. Threadgold, M. Sinclair, A. Pearce, "Self Magnetic Pinch Diode Experiments at AWE," and J. Threadgold, I. Crotch, D. Rose, and J. Maenchen, "2-D LSP Simulations of the Self Magnetic Pinch Diode," these proceedings.
- [8] D.R. Welch, D.V. Rose, B.V. Oliver, and R.E. Clark, "Simulation techniques for heavy ion fusion chamber transport," *Nucl. Meth. Phys. Res. A* **464**, pp. 134-139, 2001.
- [9] A.E. Blaugrund, G. Cooperstein, and S.A. Goldstein, "Relativistic Electron Beam Pinch Formation Processes in Low Impedance Diodes", *Phys. Fluids* **20**, 1185 (1977).
- [10] J. O'Malley, J. Maenchen, and G. Cooperstein "Status of the diode research programme at AWE", these proceedings.
- [11] B.V. Weber, R.J. Allen, B.G. Moosman, S.J. Stephanakis, F.C. Young, N.R. Pereira, and J.R. Goyer, "Improved Bremsstrahlung From Diodes With Pulse-Heated Tantalum Anodes," *IEEE Trans. Plasma Sci.* **30**, 1806 (2002).