



# INTRODUCTION TO AEROSPACE

UNITED  
STATES

20140911012

PUBLISHED  
BY

NATIONAL HEADQUARTERS, CIVIL AIR PATROL ; MAFB, ALABAMA 36112



This document may not be reproduced in whole or in part without permission from Headquarters, Civil Air Patrol—USAF.

Second Edition, 1972

## PREFACE

*Introduction to Aerospace* is the first in a series of textbooks published by National Headquarters, Civil Air Patrol, for use in Civil Air Patrol's aerospace education programs.

It is designed for use in the CAP cadet program, in junior and senior high school aerospace education courses, and for orientation programs and courses for teachers and other adults. It is accompanied by an instructor guide, a student workbook, and a series of 35mm slides.

The instructor guide and workbook contain behavioral objectives for each lesson. These objectives, the textbook, and the test are correlated so that the textbook and the workbook can be used effectively in a self-instructional way as well as in a formal classroom course.

## ACKNOWLEDGMENTS

Grateful acknowledgement is extended to the management and personnel at Piper Aircraft Corporation's Vero Beach plant for their assistance with the compilation of Chapter 4. And many thanks go to NASA engineers at the Marshall Space Flight Center, Huntsville, Alabama, for their help with the brief explanation in Chapter 5 of how the Saturn launch vehicles were built.

## CONTENTS

	<i>Page</i>
<b>CHAPTER 1. FLIGHT—THOUGHTS, TRIALS, AND SUCESES</b>	
Introduction . . . . .	1-1
Thoughts and Legends . . . . .	1-3
Lighter-than-air Flight . . . . .	1-5
Heavier-than-air Flight . . . . .	1-12
Parts of the Airplane . . . . .	1-16
<b>CHAPTER 2. DEVELOPMENTS FOR MILITARY APPLICATIONS</b>	
World War I . . . . .	2-1
World War II . . . . .	2-7
Contemporary Military Aircraft and Missiles . . . . .	2-14
Fighters . . . . .	2-14
Bombers . . . . .	2-15
Strategic and Tactical Reconnaissance Aircraft . . . . .	2-16
Attack Aircraft . . . . .	2-16
Patrol and Antisubmarine Warfare (ASW) Aircraft . . . . .	2-18
Counterinsurgency (COIN) Aircraft . . . . .	2-18
Helicopters . . . . .	2-18
Rocket Missiles . . . . .	2-19
Transport Aircraft . . . . .	2-22
<b>CHAPTER 3. CIVIL AVIATION</b>	
Civil Aviation Categories . . . . .	3-1
General Aviation . . . . .	3-1
U.S. Civil Air Carriers . . . . .	3-3
The Air Transport Industry . . . . .	3-4
Regulation of Civil Aviation Traffic . . . . .	3-8
Airways . . . . .	3-10
Airports . . . . .	3-12
The Aerospace Manufacturing Industry . . . . .	3-13
<b>CHAPTER 4. HOW A SMALL AIRPLANE IS BUILT</b>	
The Preliminary Proposal . . . . .	4-1

	<i>Page</i>
Development Engineering . . . . .	4-3
Manufacturing Engineering . . . . .	4-8
Tooling . . . . .	4-10
Electronics . . . . .	4-14
Instruments . . . . .	4-15
Receiving . . . . .	4-15
Fabrication and Assembly . . . . .	4-16
Fabrication . . . . .	4-16
Assembly . . . . .	4-30
Air Worthiness Certification . . . . .	4-36
Manufacturing Support Functions . . . . .	4-38
Quality Control . . . . .	4-38
Marketing and Sales . . . . .	4-39
Personnel . . . . .	4-41
<b>CHAPTER 5. BUILDING THE BIG BIRDS</b>	
The C-5 Galaxy . . . . .	5-1
The Saturn V Launch Vehicle . . . . .	5-5
<b>CHAPTER 6. SUPPORT INSTALLATIONS AND DEVICES</b>	
Airports . . . . .	6-2
Aids to Navigation . . . . .	6-7
Aids to Pilots . . . . .	6-8
Launch Systems . . . . .	6-11
Guidance Systems . . . . .	6-13
Tracking Systems . . . . .	6-15
<b>CHAPTER 7. FEDERAL GOVERNMENT CONTROLS AND SERVICES</b>	
The Civil Aeronautics Board (CAB) . . . . .	7-1
The Federal Aviation Administration (FAA) . . . . .	7-2
The National Transportation Safety Board (NTSB) . . . . .	7-6
The National Bureau of Standards . . . . .	7-8
The National Aeronautics and Space Council . . . . .	7-9
The National Aeronautics and Space Administration (NASA) . . . . .	7-10

	<i>Page</i>
The Federal Communications Commission (FCC) . . . . .	7-14
The National Oceanic and Atmospheric Administration . . . . .	7-15
The National Weather Service . . . . .	7-15
The Department of Defense (DOD) . . . . .	7-16
Coordination of Air and Space Activities . . . . .	7-18
 <b>CHAPTER 8. SOCIETY AND AEROSPACE DEVELOPMENTS</b>	
Transportation . . . . .	8-1
Communications . . . . .	8-4
Navigation . . . . .	8-6
Education . . . . .	8-7
Medicine and Health . . . . .	8-9
Products . . . . .	8-11
 <b>CHAPTER 9. PREPARATION FOR THE AEROSPACE AGE</b>	
Introduction . . . . .	9-1
Junior Colleges . . . . .	9-1
Technical/Vocational Schools . . . . .	9-3
Institutes . . . . .	9-4
Four-year Colleges/Universities . . . . .	9-5
Graduate Schools . . . . .	9-9
Armed Forces Schools . . . . .	9-12
 <b>CHAPTER 10. AERONAUTICS, ASTRONAUTICS, AND THE FUTURE</b>	
The Realm of Aerospace . . . . .	10-1
Aeronautics . . . . .	10-5
Astronautics . . . . .	10-8
Unmanned Spacecraft . . . . .	10-10
Manned Spacecraft . . . . .	10-12
 <b>APPENDIX. GLOSSARY . . . . .</b>	 A-1 through A-5

# CHAPTER 1



FIGURE 1 Wan Hoo and his space vehicle

FLIGHT—THOUGHTS, TRIALS, AND SUCCESSES

## INTRODUCTION

Today we live in a world where the doctrine of aerospace power— aerospace leadership—is necessary not only to insure a nation's economic health, but also to insure the very survival of that nation. Regardless of whether we are talking about the United States, the Soviet Union, or any other nation that strives to become a world leader, that nation subscribes to the doctrine of aerospace power. Without this doctrine, any nation becomes a second rate power.

The doctrine of aerospace power, even though it is vital to our survival, is either unknown or misunderstood by the citizenry of this nation. To insure the maintenance of our aerospace leadership, it is therefore also vital that our citizenry be informed about aerospace developments and understand the importance aerospace power plays in our national policy. This can be accomplished only through a comprehensive aerospace education program which reaches the majority of the population.

We must not confuse aerospace education with aerospace training. Aerospace training is preparation to enable a person to participate in some aerospace activity. Whether this is training to be a pilot, engineer, stewardess, flight surgeon, or mechanic, it falls in the category of training (Chapter 9). Aerospace education is designed to enable our populace to understand the doctrine of aerospace power. This course, which you are beginning with this text, is an aerospace education course. It is designed to provide understanding—not career training. Let's begin by looking at what is meant by aerospace power.

Aerospace is defined as the expanse beyond the Earth's surface and includes the region which classically has been called the Earth's atmosphere and also the space environment beyond. We believe that the aerospace environment is one medium, not two; that the density of the Earth's atmosphere diminishes as you go higher; but at no point does the atmosphere abruptly stop and space begin. Aerospace power is a nation's capacity to act in this expanse beyond the Earth's surface. This is not, as many people suppose, only the ability to use the aerospace environment for hostile purposes, but rather it is the total aerospace activity of a nation—civilian and military, commercial and private, potential as well as existing.

A nation's capacity or ability to use the aerospace environment is determined by many factors. Among the most obvious of these are (1) the civilian aerospace community, including all commercial, pri-

vate, or other non-military aerospace activities, together with its air and spacecraft, equipment, personnel, and supplies, and (2) the military aerospace community, including all its military aerospace activities, together with its aircraft and spacecraft, equipment, personnel, and supplies.

Other factors which contribute to a nation's aerospace power are its aerospace facilities (airports, meteorological facilities, repair and maintenance, etc.), and its aerospace industries (manufacturing, research, engineering). These two factors, however, (facilities and industries) are dependent upon the civilian and military communities for their existence. For example, if there were no civilian air fleet, there would be no need for an industry to build airplanes nor for airports to land them.

These are all evidences of the present status of a nation's aerospace power and are visible national assets. However, equally or possibly even more important are the factors which determine a nation's potential aerospace power. These factors, which contribute to or limit a nation's aerospace power, include such things as: (1) geographic conditions; (2) resources; (3) industrial development; (4) political conditions and (5) population.

We can all think of examples of nations whose aerospace power is limited, or even non-existent, because of geographic conditions (location, size, climate and weather). It is also obvious how lack of resources (economic or technological) will impose limitations on a nation's capacity to act. Less obvious, but equally as limiting, are a nation's politics and its population. This is particularly true in a democracy. A democracy's aerospace power is controlled by the temperament and general educational level of its population and by government policies and national incentives just as much as it is by any other of the factors we have discussed.

Historically, one of the greatest assets of the American people has been their pioneering spirit. This is as true in aerospace as in any other area. We have always had a sense of national pride in our excellence and our leadership in aviation and in our space program. This pride and spirit have been as much responsible for our aerospace power as any other factor. Recently however, we have seen an erosion in our aerospace programs which has been caused not by a lack of ability, but rather by both a lack of interest by our citizenry and by changing national incentives. Regardless of the cause, the effect is the same. This nation is being placed in a position of jeopardy in both military

and commercial aerospace programs. You are taking the first step toward overcoming these problems by taking this aerospace education course and preparing yourselves to understand our aerospace world.

## THOUGHTS AND LEGENDS

When did our ancestors first think about flying over obstacles such as trees, boulders, rivers, and mountains? No one can assign even a specific millennium to the momentous occasion. It could have happened during one of the first few free moments when a prehistoric man of a half million years ago was not fighting off vicious predators or busily searching for something edible to sustain his life. Perhaps he awoke one morning, looked out the opening of his cave dwelling, high in the mountainside, and dreaded the long and difficult trip to the game-laden valley below—where he would obtain his first meal of the day. Then perhaps he noticed the birds of prey flying effortlessly from their lofty perches down to the same valley for the same purpose, and reasoned that if he could do the same how much better life would be for him.

Of course this is pure speculation, but it could have happened that way. We can go further with our speculation and say that perhaps the same early man put his thoughts into practice by eventually fashioning crude wings and trying his scheme; then we may reason that if he did, it didn't work. Otherwise we might have had proof of manned flight much earlier than the 19th century, A.D.

Before the first successes, there were many who thought about and tried flight, beginning with the first recorded histories.

In the 23rd Century Before Christ, the legendary Chinese Emperor Shun is said to have invented a successful flying apparatus—or machine—which was based on the principles of bird flight, complete with flapping wings (an ornithopter). Perhaps the emperor made the machine and perhaps it worked, but many men since the emperor's day used the same flapping-wings technique for their flying machine inventions and none of them succeeded.

Another invention attributed to Shun is slightly more plausible. When he was a small boy, Shun's father decided to kill him—or send him to his ancestors, as the Chinese of that time believed. So the father found a reason to coax Shun to climb to the top of a granary. Then the father set fire to the granary base. It wasn't long before Shun found himself in a predicament that only his highly inventive mind and skill

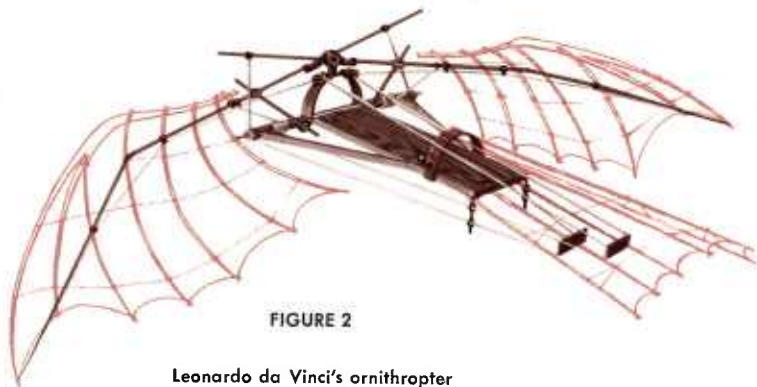

FIGURE 2

Leonardo da Vinci's ornithopter

in matters of flight could get him out of. Fortunately, there happened to be two reed hats near by, so Shun quickly fashioned the hats into a makeshift parachute. This allowed him to descend to the ground unharmed. Considering the size of Chinese reed hats and the no doubt small size of Shun, this could have happened.

Very much on the ridiculous side is the legendary power of another Chinese, Ki-Kung-Shi. In the 18th Century, B.C., he reportedly fashioned a chariot with which he could easily ply the skies. There is no mention of how Ki-Kung-Shi managed to get his chariot into the air, but, once aloft, he propelled it with a sail, according to legend.

Chinese preoccupation with attempts to fly led to other tales in the realm of pure fantasy. An example is the story told about Liu An, in the 2nd Century, B.C. It seems Liu An concocted a *levitation* elixir. After drinking it, he promptly ascended into the atmosphere. On the way up, he accidentally dropped the container into his courtyard; the dogs and poultry confined in the courtyard drank the elixir dregs, and promptly joined Liu An. This legend, we should note here, is probably the first account of lighter-than-air travel.

Going to the other side of the globe and visiting the Caucasian world, we find an early account of manned flight in England. The story goes that, in the year 852 B.C., King Bladud, the legendary 10th King of England, fashioned a pair of wings from feathers. He attached the wings (in some manner) to his body. Thus equipped, the ruler of England found a suitable height from which he could launch himself into the atmosphere and fly like a bird. Shortly after the launch, England was ready for a new king—Bladud was dead.

Thoughts about and trials at flight before the Birth of Christ certainly were not limited to China or England. The peoples of such places as India, Egypt, Persia and Babylonia depicted their concepts of human form in flight through legends, works of art, and *hieroglyphics*.



FIGURE 3  
Francisco de Lana;  
1670

The legends, pictures, and writings of early peoples all may have dealt with fantasies, but we can thank the originators of these fantasies for their help in perpetuating mankind's thoughts about and efforts toward flight. For instance, the legend about Liu An's elixir may have helped to inspire man's first partial overpowering of the force of gravity in a lighter-than-air device.

### LIGHTER-THAN-AIR FLIGHT

Possibly the first man to design a lighter-than-air airship was an Italian Jesuit priest, Francisco Lana. By 1670 A.D., it had been determined that air gets thinner and weighs less as *altitude* increases. Using this knowledge, Lana reasoned that copper globes with most of the air removed could be used as the lifting force for a manned, boat-shaped car. And he wrote a treatise on the scheme, complete with design



FIGURE 4

de Rozier; 1783

drawings. The copper globes, he planned, would be attached to the man-carrying car by strong ropes. When air was pumped out of the globes, the entire assembly would travel upward into the atmosphere as the light weight air left in the globes rose to seek its place with air of equal weight. Once aloft, the craft would be propelled by a wind sail (remember Ki-Kung-Shi's flying chariot?) and oars. Lana's plan could not work, but the idea of lighter-than-air flight gained momentum from the widespread reading of his treatise.

The discovery of hydrogen gas by Henry Cavendish in 1776 and experiments with the lightness (thinness) of heated air finally launched man into lighter-than-air flight. In France, Etienne and Joseph Montgolfier first experimented with Cavendish's hydrogen gas in attempts to fly small model balloons, but the gas always escaped through the balloon envelopes' porous paper. They then tried hot air experiments.

In 1782 the Montgolfier brothers succeeded. They used a small silk bag, and suspended burning paper under it in a manner that allowed the heated air to enter the bag through an opening at the bottom. As the balloon filled with the heated air, it rose until it reached the ceiling of the room in which their experiment was conducted. This success encouraged them to keep experimenting toward greater achievements.

By 1783 the Montgolfier brothers had built a balloon capable of lifting a considerable weight. In September, they demonstrated their balloon's lifting power to the King and Queen of France by placing a sheep, a chicken and a duck in the balloon car. The demonstration was an outstanding success, especially so since the balloon returned to earth without injury to its passengers.

About one month later (15 October 1783), another Frenchman came through with a "first." Francois Pilatre de Rozier anchored a hot air balloon to the ground so that it could rise only "so high." (De Rozier was not eager to take too many chances at this point.) With De Rozier in the car, the balloon rose 80 feet, making him the *first man to ascend in a balloon*.

On November 21 (still 1783), De Rozier and the Marquis d'Arlandes made the *first free flight* in one of the Montgolfiers' hot air balloons. The aerostat, as any lighter-than-air craft may be called, ascended easily into the atmosphere to an altitude of 280 feet. Twenty-five minutes later and after having traveled a distance of five and one-half miles, De Rozier and his passenger, d'Arlandes, landed in a

field outside Paris. De Rozier continued to fly until he died while attempting a balloon crossing of the English Channel.

Professor Jacques Charles (another Frenchman) had been experimenting with hydrogen and some means to contain it in an enclosure or envelope. He succeeded by rubberizing an envelope made of silk. Charles and the Robert brothers built a two-man hydrogen balloon and had it ready to fly on December 18, 1783. Charles and M. N. Robert entered the car and went on a long distance flight (for that time). They traveled, or floated, about 27 miles, and stayed aloft for more than two hours. Upon landing, Professor Charles decided to make a flight by himself. To his surprise, the balloon rose rapidly without the additional weight of his companion. Within twenty minutes he was at 10,000 feet altitude. By venting the hydrogen and skillful use of ballast, Charles was able to land safely some time later, but he complained of the cold and intense pain experienced at peak altitude. We can conjecture that this experience frightened Professor Charles because he never went up again.

Although we consider Charles and M. N. Robert to have made the first long distance flight, the feat that Jean-Pierre Blanchard performed was the most daring of the early long-distance flights. On January 7, 1785, Blanchard and his companion, Dr. John Jeffries (an American), took off from Dover, England, and crossed the English Channel to land approximately 12 miles inland from Calais, France.

Balloon flights had become fairly commonplace in the late 1780s and early 1790s, and the balloonists were looking toward refinements. They could go up and travel some distance, but there were two problems: They could not control the direction of travel and they needed some means of propulsion against the winds encountered. All kinds of apparatuses were tried. After all, the balloonists reasoned, air and water behaved in basically the same manner. Boats traveling on water used sails and oars for propulsion, and rudders for steering. Thus it seemed reasonable to them that the devices used on boats would obtain the same results on balloons.

Again and again the balloonists tried. They used oars, paddle wheels, "air screws" (propellers), rudders, and sails. Even Blanchard tried silk-covered aerial oars and a rudder on his channel crossing in 1785. The idea was basically sound, but most of the propulsion system designs relied on human body muscles as their power sources, and man simply cannot supply the power required—over a significant period of time.

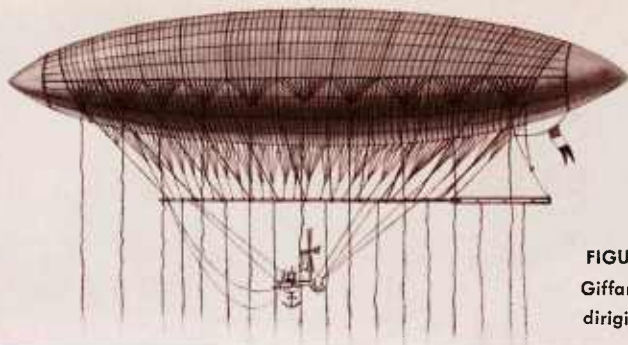

FIGURE 5  
Giffard's  
dirigible; 1852

M. Henri Giffard, a French engineer, was the first experimenter to use mechanical power for a balloon, or *dirigible* as a steerable balloon craft is known. Giffard designed a special steam engine for aerial use. His engine weighed 350 pounds and generated about 3 horsepower; yet it was powerful enough to turn an eleven-foot propeller at 110 revolutions per minute.

In 1852, Giffard built a dirigible with a cigar-shaped envelope which was 144 feet long and 40 feet in diameter. Covering the envelope was a net from which a beam was suspended. The aeronaut's car, engine, and propeller were suspended from the beam. Extending outward from the rear of the beam was a rudder, of sorts.

Giffard's dirigible was successful. It reached a speed of about six miles an hour, and it responded to directional changes of its rudder.

A new propulsion power source for dirigibles was used in 1883. Albert and Gaston Tissandier (Frenchmen again) fitted a small dirigible with an electric motor capable of developing about  $1\frac{1}{2}$  horsepower. The motor drove a two-blade propeller which had a diameter of nine feet. Although their dirigible couldn't be considered the greatest success, the Tissandier brothers could maneuver it. On one experimental flight they were able to "fly" within a specific area, even though an eight-mile-an-hour wind was blowing.

French Army Colonel Charles Renard improved the electric power propulsion technique. It took a varnished silk envelope 165 feet long to lift Renard's 1,174 pounds of electric motor and accumulators



FIGURE 6 Renard's dirigible; 1884



(storage batteries), along with the bamboo car and passengers. The nine horsepower motor turned a propeller of 23 feet in diameter. Renard mounted the propeller in front of the car, and installed vertical and horizontal steering rudders at the rear. The horizontal rudder was the most important steering innovation because it allowed some control of ascent and descent.

Colonel Renard proved the feasibility of his ship on its first flight, which occurred August 9, 1884. He kept her aloft for 23 minutes, and traversed a circular route of about five miles. The speed he attained during this first flight was 14 mph. In addition to the increased speed, he demonstrated the effectiveness of his new rudder system through maneuver exercises.

Further experiments with Colonel Renard's electric-powered dirigible culminated in a flight over Paris in September of 1885. High French officials were present to judge the worth of his invention. Although the flight was successful, the authorities could see no real future in a device that had to have such weight as part of its propulsion system. Obviously the weight and limited power source would restrict the dirigible to very short flights, and could not warrant government expenditures for further development. Hence, work on electric powered dirigibles ended.

Preceding successful use of internal combustion power plants for dirigible flight was a noteworthy attempt by Herr Paul Haenlein of Germany. We mentioned Herr Haenlein to give him credit for trying and for an inventive approach. He used an internal combustion engine with developed approximately six horsepower, but its fuel (coal gas) was drawn from the dirigible's *envelope!* Captive flights were made by Herr Haenlein, but he made no further innovative experiments or free flights because he ran out of funds.

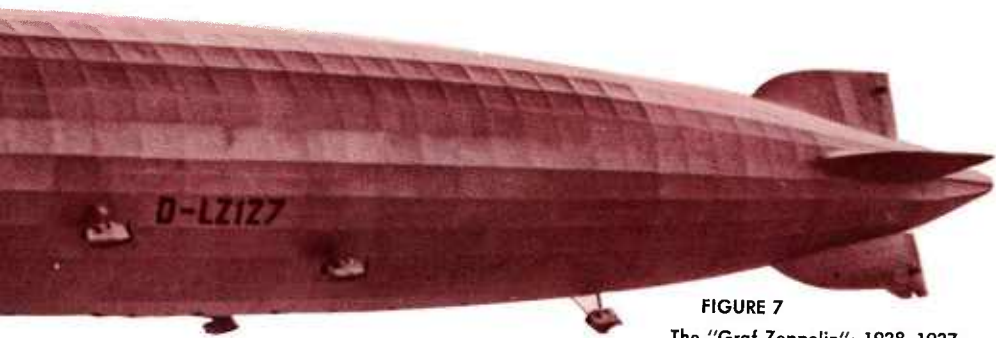

FIGURE 7  
The "Graf Zeppelin"; 1928–1937

In 1879, two German experimenters, Baumgarten and Wolfert, used a benzine-fueled internal combustion engine to power their dirigible, but it got out of control and crashed. Later, Dr. Wolfert died with a passenger in another dirigible when, at about 600 feet, the engine's exhaust apparently ignited the envelope.

Lighter-than-air experimentation eventually produced successes that made passenger pay loads practicable, thanks primarily to the work of German Count Ferdinand von Zeppelin and Brazilian Albert Santos-Dumont. The latter performed his work in France. Santos-Dumont was concerned with non-rigid (flexible) dirigibles, and it was he who, in 1901, won 125,000 francs for flying a prescribed course within a time limit.

Von Zeppelin, in the meantime, was perfecting the rigid dirigible. Von Zeppelin constructed huge craft with a rigid but lightweight interior framework. Inside the framework he put separate bags to hold the gas, and then, for aerodynamic purposes, covered the whole skeleton with cloth.

At about the same time, other developments were taking place in dirigible construction and travel, but the German Zeppelin series eventually came to be the most spectacular success because of size and use. For instance, the Zeppelin Hauser, with a passenger capacity of 99, carried a total of 35,000 passengers—between 1910 and 1914—without accident. Germany found dirigibles to be effective bombers during World War I. From dirigibles, the Germans bombed London, and, although they doubted the destructive effectiveness, they evidently considered the psychological effects to have been satisfactory.

Early Zeppelin successes influenced the United States, France, and Britain to purchase ships from Germany, but the sour experiences with these craft were uncanny. Each came to a tragic end, and with their crashes came an end to interest in further Zeppelin activity—except in Germany.

After WW I and as the years wore on, Zeppelin travel was further refined by the Germans. The most famous and successful turned out to be the *Graf Zeppelin*. Launched in 1928, the *Graf Zeppelin* continued in service until honorably retired in 1937. She had flown over one million miles. Once, she made a spectacular round-the-world voyage.

The Zeppelin *Hindenberg*, launched in 1936, was the ultimate in air travel. Built especially for transit between Germany and the United States, the *Hindenberg* could carry 50 passengers in elegance and comfort on a speedy 58-hour flight across the Atlantic. There were private staterooms, and a grand piano provided music in the dining room, where passengers dined from china and crystal on linen-covered tables. Her last flight came in 1937. As she approached her mooring at Lakehurst, New Jersey, she burst into flames and crashed.

After the loss of the *Hindenberg*, further efforts to make dirigibles a paying enterprise for passenger travel ceased; however, some responsible people of our time contend that dirigibles still can be a useful and pleasurable mode of transportation, and that they may again enjoy a position of importance as freight carriers.



FIGURE 8 The death of the "Hindenburg"; 1937

## HEAVIER-THAN-AIR FLIGHT

Legend has it, as we have seen, that people were flying centuries before the Birth of Christ. On the other hand, we think of the Wright Brothers as having been truly the first men to fly in an airplane, but we seldom read the "fine print" and stop to realize that they were the first to build and fly a *powered* passenger-carrying airplane.

While balloons and dirigibles were in the air and carrying passengers, the heavier-than-air enthusiasts were to continue their experiments for 120 years before the Wright Brothers finally put together knowledge gained by earlier experimenters, plus their own, and made the dream of powered flight come true. Most of the pioneering aviationists could not divorce themselves from the idea of flying in the same manner as the birds. Since birds flap their wings to fly and do a good job of it, the early experimenters reasoned that man should do the same. The ornithopter, they thought, had to be the answer.

By 1800, most experimenters had realized that the man-powered ornithopter couldn't work, but they still thought the flapping wing might work if it could be powered mechanically. Toward this goal much effort was wasted.

In England, one of the world's great inventive minds was working on a new concept for heavier-than-air flight—a fixed wing. In 1804, Sir George Cayley constructed a whirling-arm device to test the resistance and lift of a miniature "wing" as it traveled through air. No doubt it was the knowledge Cayley gained from this experiment that led to his construction in the same year of the world's first *model* glider.

Cayley's glider consisted of an ordinary kite fixed to a pole (fuselage), and a tail plane and fin (horizontal and vertical stabilizers). Oddly enough, the kite, which uses fixed-wing aerodynamics, had been flown in China for many centuries, and in Europe since the 15th Century. But Cayley was the first to recognize and use its aerodynamic principles for free glider flight. On his 1804 model, he *inclined* the kite portion at an angle of incidence of about six degrees. The angle, in effect, produced an angle of attack that provided greater lift by allowing the wind to pass up and over the "wing." (You will learn more about lift in the textbook AIRCRAFT IN FLIGHT.)

The tail unit of Cayley's glider was attached to the pole by a universal joint. The joint allowed adjustment to any angle so that Cayley could control the glider's flight by preadjusting the tail unit's angle.



FIGURE 9 Cayley's glider; 1853

Cayley's 1804 "whirling arm" experiments and the model glider were of tremendous historic importance—the true beginning of fixed wing aircraft research.

From 1804 until 1853, he continued to develop improved gliders. In 1849, he built a triplane glider and sent it skimming down a hill with a boy as a passenger. In 1852, he designed another man-carrying glider and persuaded his reluctant coachmen to glide across a small valley. In 1853, at 80 years of age, he designed his most advanced glider. Along with these experiments, he designed dirigibles and helicopters far beyond his time.

Cayley wrote and published significant papers describing his aerodynamic experiments and theories. Among his findings was that wings should have *camber* (curved surfaces) to smooth and curve the air flow over them, and that wings with *dihedral* (a "v" angle) give an aircraft lateral stability and that tail surfaces are necessary for longitudinal stability. In short, it was Cayley whose genius laid the foundation for future developments in heavier-than-air flight.

His work was directly responsible for the next significant step in fixed-wing aircraft development—on the "model" level—taken by two of his contemporaries, also Englishmen—W. S. Henson and John Stringfellow. In 1842, Henson, who carefully studied Cayley's theories and experiments, designed the first steam-powered, propeller-driven, passenger-carrying aircraft. This design, with a 150-foot wingspan, never got off the drawing board, but it was another important "first."

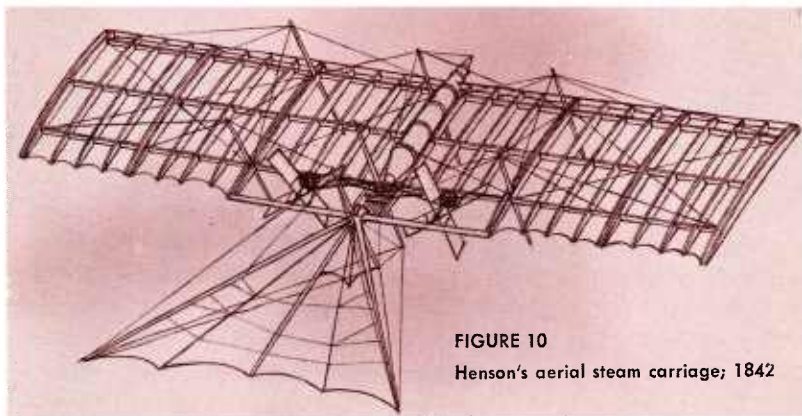

FIGURE 10

Henson's aerial steam carriage; 1842



FIGURE 11 Lilienthal's glider, 1895

Henson and Stringfellow built a model of the ambitious design with a 20-foot wingspan. In 1847, the model was tested but achieved merely a “descending glide.” One reason it did not fly was that the steam engine was too heavy.

Henson gave up, but Stringfellow continued experiments based on Henson's designs. He built a model with a 10-foot wingspan and a small steam engine to power it. When he tested it in 1848, it achieved a part-powered, half-glide. Even though the test was made with a model, it was at that time considered to be the first time an airplane actually flew under power.

Ornithopter proponents did not give up because of Cayley's, Henson's, and Stringfellow's demonstrations. So it was with Frenchman Hureau DeVilleneuve. DeVilleneuve reasoned that he could achieve flapping-wing flight if he could devise a way to avoid lifting excessive weight.

To power his craft, which had a wingspan of almost 50 feet, he used a steam engine, but, ingeniously, he left the heavy boiler on the ground. Running from the boiler was a long flexible tube to the steam engine in the body of his ornithopter. Sometime in 1865, DeVilleneuve boarded his machine and turned on the steam. Abruptly the craft rose, vigorously flapping its wings. The pilot was probably

both surprised and frightened because he quickly turned the steam off and the craft crashed to the ground. Apparently this first experience was enough for DeVilleneuve—he never tried flying his ornithopter again.

Around 1867, two German brothers, Otto and Gustav Lilienthal, started experimenting with fixed-wing glider flight. At the time they were young men and soon had to cease their experiments to take part in the Franco-German war. Upon returning from the war, only Otto resumed working with glider experiments because Gustav had lost interest. By 1891, Otto had made enough progress to start serious flying with his man-carrying glider. At first, Lilienthal ran and launched himself from a springboard. Eventually (1892) he had a large earthen mound built to use as his launch platform. On several occasions, his launches from the man-made mountain resulted in flights of more than 100 feet.

Lilienthal used cambered wings to improve his gliders but he continued to rely on shifting his body to change the glider's attitude (angle of attack). His final contribution was a movable rear elevator which served to change the angle of attack by elevating or depressing the glider's tail section. The elevator control was attached to the pilot's head. When the pilot bent his head forward, the elevator was raised—depressing the tail section and, consequently, raising the forward section. It was with this new glider that Lilienthal met his death (1896). Something happened when he reached an altitude of 50 feet and the glider crashed, breaking Lilienthal's spine.

All over the "enlightened" world, pioneering efforts were made by men to solve the problems of heavier-than-air flight, and it is not our purpose to expound on their exploits. There were too many and credit to a few would do injustice to the rest. It is important that the Wright Brothers were among the early glider flyers, and that their many experiments led to the final step before their historic flight—to apply power to the glider.

The Wright Brothers constructed their own gasoline engine, and fitted it, along with specially made propellers, to one of their gliders. At Kitty Hawk, North Carolina, on 17 December 1903, the Wright Brothers achieved powered, controlled flight. Since then, great and rapid progress in powered flight has been made.

In Europe, where the first ascensions in balloons had occurred, attention had turned to airplane flight, and almost every conceivable design was constructed and flown—with varying successes.

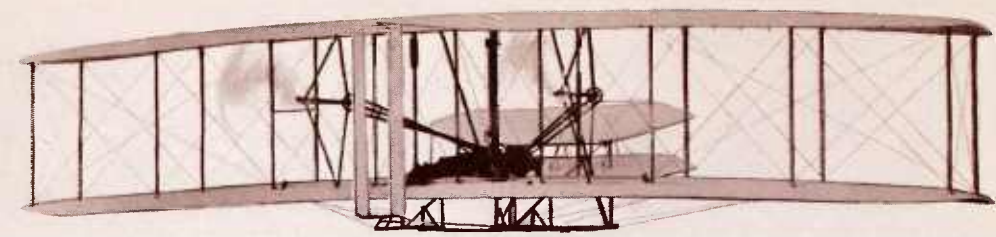

FIGURE 12A—The "Wright Flyer," 1903



FIGURE 12B—The "Wright Flyer," 1906

It was only a few years after the Wright Brothers' development that long-distance flights became a reality. In 1908, Wilbur Wright took off and remained in the air for over two hours, and covered a distance of 90 miles. In France and one year later, M. Louis Bleriot took off from France, flew across the English Channel and landed near Dover Castle 37 minutes later. In the same year (1909) the world's first international week-long flying meet took place in Reims, France. Pilots representing several nations flew, established, and broke records involving distance, speed, and altitude.

By 1910, the airplane had been adapted to water operations. On the 28th of March, Henri Fabre took off from water in the first float plane, and then made a successful landing on water. In 1913, Roland Garros, another Frenchman, made the longest over-water flight since the invention of the airplane. Garros piloted his airplane—a land plane—across the Mediterranean Sea for a distance of 460 miles. This feat preceded World War I by about one year. Once the war had started, even more rapid advancement in the science of airplane construction and flight occurred because of discoveries for using airplanes as tools of war.

### PARTS OF THE AIRPLANE

At this point in time the basic parts of an airplane had been established, and these parts continue to be the basic parts of modern air-

planes. Let's name them: First there is a fuselage. In the fuselage are the pilot, passengers, and baggage. Attached to the fuselage are the wings. Wings provide the lift that keeps the airplane flying. Attached to the rear of the fuselage is the tail section, called the empennage, which consists primarily of a vertical fin and a horizontal stabilizer. The fin helps keep the airplane from yawing left or right, and the stabilizer helps keep the airplane from pitching up or down. Attached to either the fuselage or the wings is the engine(s) which provides the power that enables the airplane to fly.

Control surfaces are essential parts of the wing and the empennage. Ailerons on the wings can be deflected upward and downward by the pilot to control rolling of the aircraft along its longitudinal axis. The ailerons are used in turns and other maneuvers. Movement of the rudder, which is attached to the vertical fin, permits the pilot to "steer" right or left; and movement of the elevator, which is attached to the stabilizer, allows the aircraft to pitch upward or downward, or to climb or descend. (Note: The fin portion of the empennage may be called the vertical stabilizer.)

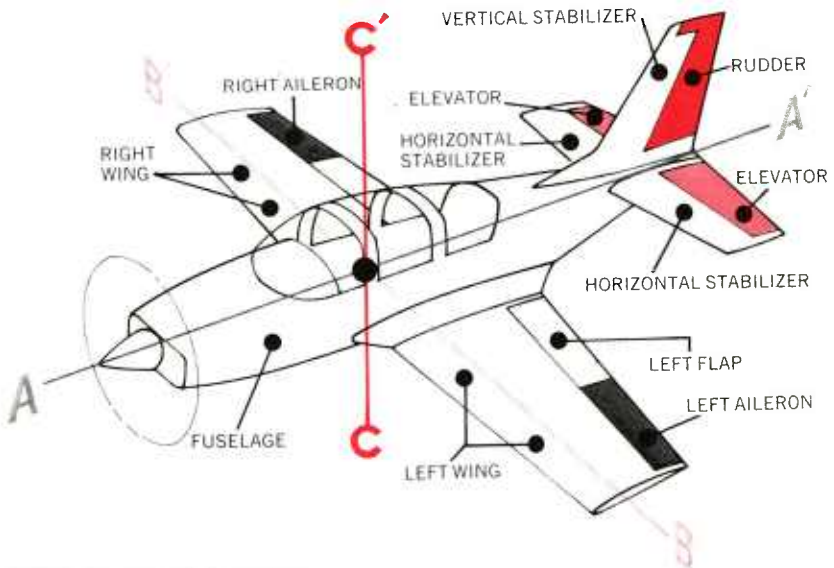

FIGURE 13 Parts of the airplane

# CHAPTER 2

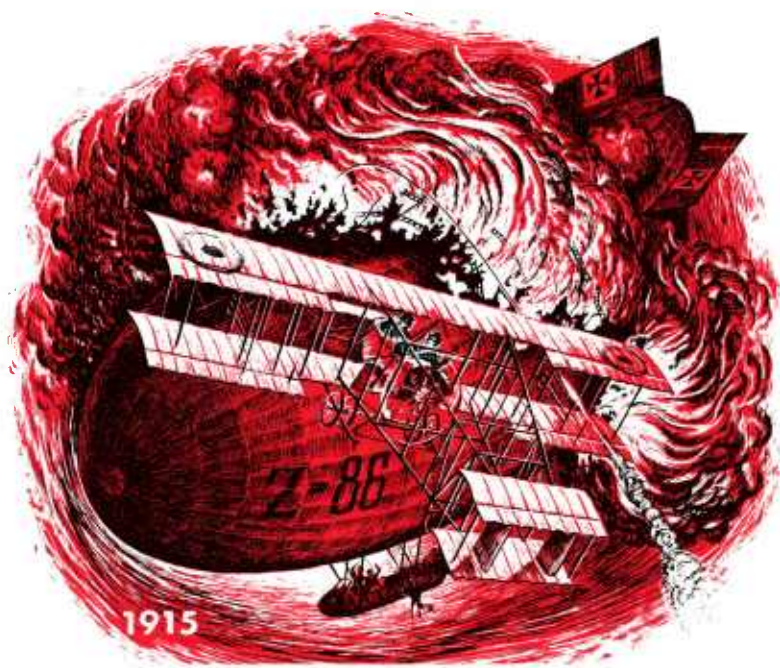

FIGURE 14 Balloon "busting", World War I; 1914–1918

DEVELOPMENTS FOR MILITARY APPLICATIONS

Unfortunate as it is, we must recognize the fact that war, including offensive and defensive preparations, has been one of the main factors in the rapid development of aircraft and rockets. Looking on the brighter side, we can see that the effect has been to advance technology. Without the aeronautical advances brought about by the military application of aircraft, it is possible that we could today be flying airplanes not much improved over the Wright Flyer.

## WORLD WAR I

During the early months of World War I, balloons, dirigibles, and airplanes were in the air over France. As the war continued, new and better aircraft came from the drawing boards and factories of the principal adversaries, and tactics changed as hardware changed.

At first, both the lighter-than-air aircraft and airplanes were used for observation. Balloons had been used as early as the Civil War for observation, but, by 1914, refinements had brought them into much wider use.

Lighter-than-air aircraft were constructed in three different types: the "flexible or non-rigid," the "semi-rigid," and the "rigid." The balloons used were not steerable, and were tethered to the ground by a cable assembly. They were raised or lowered by cable, and their main use, as we have indicated, was as observation platforms at the front lines. They carried an observer who rode in a basket suspended several feet below the gas bag, or envelope. With a "sausage" configuration, extensions tailward in the shape of fins, and the angle of incidence caused by the tethering arrangement, these balloons "flêw" in a manner similar to kites—hence they were dubbed "kite balloons."

The flexible dirigibles took their shape strictly from the design of the gas bag and the pressure of the gas filling them. Their cars, suspended by a cable system, contained space for the pilot and crew. Some of the earlier models used cars that looked very much like the fuselage of an airplane, complete with engine, but their control surfaces consisted of horizontal and vertical rudders which guided the craft up or down or to the right or left. Being maneuverable and small, the *blimps*, as they were dubbed by the British, took to the air to patrol coastlines, looking for enemy warships and mines.

The semi-rigid dirigibles were similar to the blimp in that their shape was mainly derived from the envelope design and gas pressure. The important difference was that they had a keel to which the pro-

pulsion system and car were attached. Semi-rigids also were used as patrol craft.

The rigids, as we know already, were much more sophisticated. They were larger (huge!), and took their shape from a rigid framework. In honor of their inventor, they kept the name Zeppelin. Zeppelins were used by naval forces as patrol craft, and used by the Germans to bomb England.

Like the balloons and dirigibles, airplanes in the early months of World War I were observational devices. Airplanes demonstrated their ability to fly quickly (relatively speaking) over the enemy's lines and return with fresh information on the tactical situation (reconnaissance). The airplanes were much more efficient than the lighter-than-air aircraft, and both sides used various types of airplanes for reconnaissance.

German pilots and French pilots waved to each other as they passed on their way to and from missions. Neither side had yet thought of using an airborne weapon to defeat the other. The first "aggressive" attempts were not long in coming, however, and they spurred necessary refinements in the design and construction of airplanes.

On August 29, 1914, German Lieutenant Hermann Dressler, in a *Rumpler Taube*, dropped four bombs on the outskirts of Paris. Germany formed the first bomber squadron soon thereafter (November 1914), and conducted the first bomber squadron raid, using Dunkirk as the target. After the success at Dunkirk, the Germans began concentrating on aerodromes as targets for their new weapon.

In the meantime, pilots of both sides had stopped waving (we can assume) and started shooting. They used pistols and rifles at first, but soon graduated to swivel-mounted machine guns fired by the observer. None of the weapons techniques worked very well. French ace Roland Garros (the same who first flew across the Mediterranean) reasoned that if a machine gun could be mounted on the airplane fuselage and fired through the whirling propeller, it would be much more efficient,

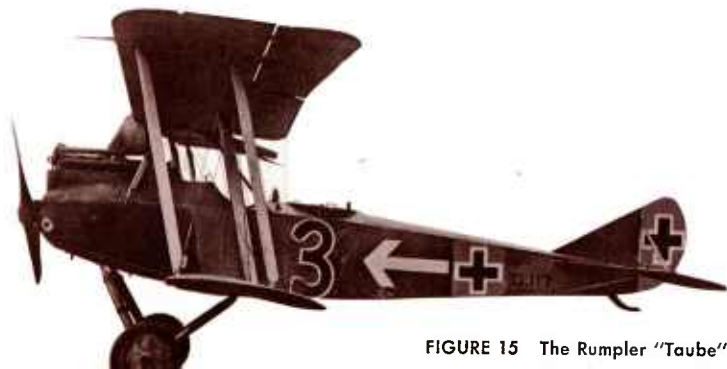

because the pilot could point the airplane as if it were a gun and hold it on the enemy until he was downed. This Garros did. He mounted an automatic rifle on the fuselage of his *Morane Monoplane*, and placed triangular steel wedges into the propeller blades. Bullets hitting the steel wedges would be deflected, supposedly causing no damage to the propeller. Garros's invention was successful—much to the consternation of the Germans.

FIGURE 16



The Morane Monoplane

Forced down behind German lines, Garros and his plane were captured, and the secret of his combat successes was out. With Garros's device serving as an inspiration, Anthony Fokker developed a synchronization system by which a machine gun could fire between the propeller blades as they rotated. Then aerial warfare really became deadly. With synchronized machine guns mounted on *Eindekker Scouts*, German pilots Boelcke and Immelmann struck terror in the hearts of Allied flyers, not because of their number (only two in the beginning), but because Allied flyers knew that the fire-spitting airplanes would deal almost certain death.

The new synchronization technique soon found its way into the hands of the French, and both sides used the increased firepower to equal advantage. More and more emphasis was placed on air power, and new airplanes were developed, both fighter types and bomber types.

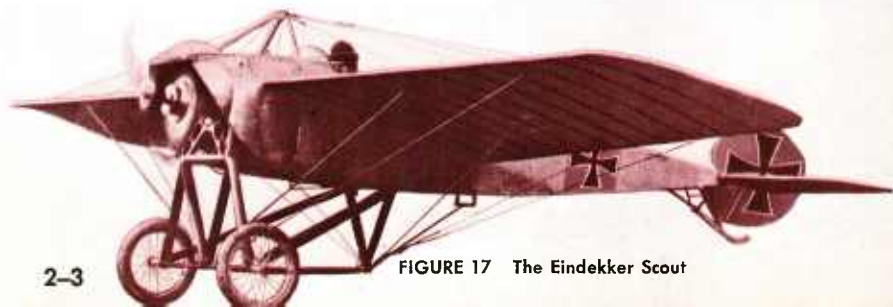

FIGURE 17 The Eindekker Scout

The French began with such flimsily-constructed aircraft as the high wing *Morane-Saulnier Parasol*, and rapidly developed the light and highly maneuverable *Nieuport 28* and the *Spad*. From their slim beginning with airplanes such as the *DeHavilland DH-2*, Britain produced the *Bristol Fighter*, the *SE-5A*, and the *Sopwith Camel*. Germany's *Eindekker Scout* was pushed aside by various other models in the Fokker series and the streamlined *Albatros*. The most streamlined airplane developed during World War I was Germany's *Roland Wal-fisch* (whale).

The United States, because of its late entry into the war, contributed its manufacturing capability instead of new aircraft. The U. S. built aircraft and engines for her Allies, perhaps the most outstanding feat having been the design and mass production of the 12-cylinder, 400-hp Liberty engine. The Curtiss Aircraft Company did produce the *Curtiss JN (Jenny)* plane which saw wide service as a trainer.

Although fighter airplanes captured most of the spotlight—because of their daring pilots—the war stimulated multiengine bombers to equal growth. The French built a twin engine *Caudron G-4*; the German twin engine *Gotha* rained its load of seven 112-pound high explosive and six 28-pound fragmentation bombs on Allied positions. The top Allied bomber of the war was the British *Handley Page*.

New fighters and bombers were on the drawing boards at the close of World War I. Several new designs were produced but too late for war work. Among these were the American *Martin MB-1* bomber and the great French *Farman Goliath* bomber.

At the end of World War I, the world realized the importance of aircraft in military activities. The United States did not enter into a program of official military aircraft production. However, research, which had military application, did go on in the area of civil aircraft. In those countries whose governments participated more directly in the national economy, military aircraft research and prototype production progressed throughout the peacetime years.

Our nation has private industry, aviation enthusiasts, and a competitive spirit to thank for our keeping up with what was then called the "air age." New planes were built to break speed and altitude records. Combat-type aircraft were designed in an effort to sell the military on purchasing production models and to make money for their manufacturers. Consequently, great strides were made in aircraft development, and the production plans drawn up for new types of aircraft paved the way for greater air operations in World War II.

Figure 18: Nieuport 28



FIGURE 19 Spad



FIGURE 20 Bristol Fighter



FIGURE 21 SE-5A



FIGURE 22 Sopwith Camel





FIGURE 23  
Albatross D-1



FIGURE 24  
Curtiss JN-4



FIGURE 25 Caudron G-4



FIGURE 26 Handley Page



FIGURE 27 Martin MB-1

## WORLD WAR II

At the outbreak of German hostilities in 1939, the prominent pictures shown on newsreels were those of German bombers ripping apart the cities of her victims. In the forefront were the *Junkers Ju-87* (*Stuka*) and the *Heinkel 111* series twin engine bomber which had been developed originally as a “commercial” aircraft. The *Heinkel 111* could carry a *blitzkrieg* bomb load of 2,200 pounds, fly at a top speed of 214 mph, and range out from home base as far as 465 miles and return. Germany, the inventor of bomber tactics, failed to emphasize larger bomber aircraft although a four engine bomber was used to bomb Allied ships. Instead, she concentrated on twin engine airplanes for use in mass raids.

FIGURE 28 Junkers JU-87



FIGURE 29 Heinkel 111

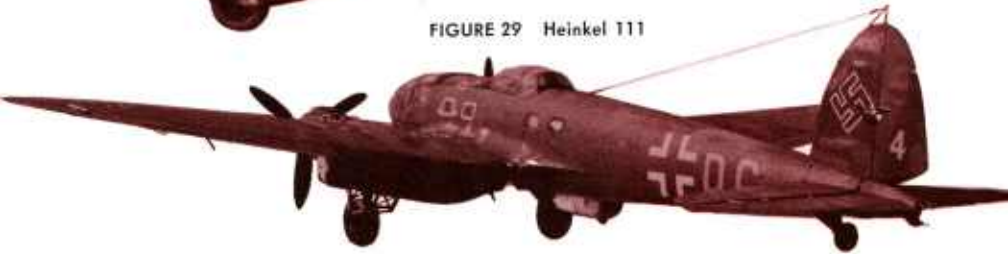

Also in the twin-engine category were fighter-bomber aircraft. The *Messerschmitt 110* in various models was used as a two-seat day fighter and a three-seat night fighter. In either configuration, the *Me 110* could travel at a rapid clip and go to rather high altitude. As a night fighter it could fly at speeds ranging from 342 mph to 349 mph when at an altitude of 22,965 feet, and in the day fighter configuration could climb to its maximum altitude of 32,000 feet.

Single engine fighters were the pride of Luftwaffe pilots. Among the many were the *Focke-Wulf Fw 190* and *Messerschmitt 109*.

The Focke-Wulf radial engine Fw 190 was a big problem for Brit-

FIGURE 30

Messerschmitt Me 110



FIGURE 31 Focke-Wulf FW 190



ish pilots since it could out-perform anything the British had in the beginning conflicts of WW II. Like all aircraft, the 190 underwent modifications as new needs and discoveries arose. By the final production model, the 190 could fly 405 mph at 20,500 feet, and could climb to 37,400 feet.

Messerschmitt's 109 underwent many modifications and was used in almost all theaters. Its final performance specifications included the ability to fly 387 mph at 22,970 feet, and climb to 39,750 feet.

Britain's front line of defense against the German aerial war machine was centered around two fighter aircraft, the *Supermarine Spitfire* and the *Hawker Hurricane*. Both aircraft were used in the Battle of Britain, and, as is generally known, with great success.

Like many other WW II fighters the *Spitfire* was a peacetime design and had been built by R. J. Mitchell primarily to compete in the Schneider Trophy race as a high speed seaplane. This it did in 1931 and came out the victor. Progressive redesign and modification left the *Spitfire* a formidable weapon because of its small size and maneuvera-



FIGURE 32

Messerschmitt Me 109

FIGURE 33 Supermarine "Spitfire"



FIGURE 34 Hawker "Hurricane"



FIGURE 35 De Havilland "Mosquito"

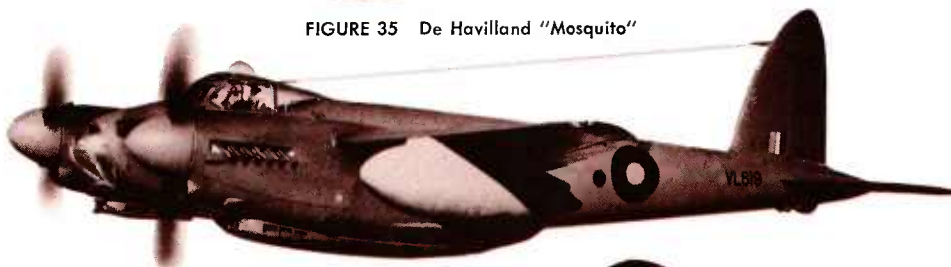

FIGURE 36  
Avro "Lancaster"



FIGURE 37 Curtiss P-40 "Tomahawk"



FIGURE 38 North American P-51 "Mustang"



FIGURE 39 North American B-25 "Mitchell"



FIGURE 40 Consolidated B-24 "Liberator"

FIGURE 41 Boeing B-17  
"Flying Fortress"

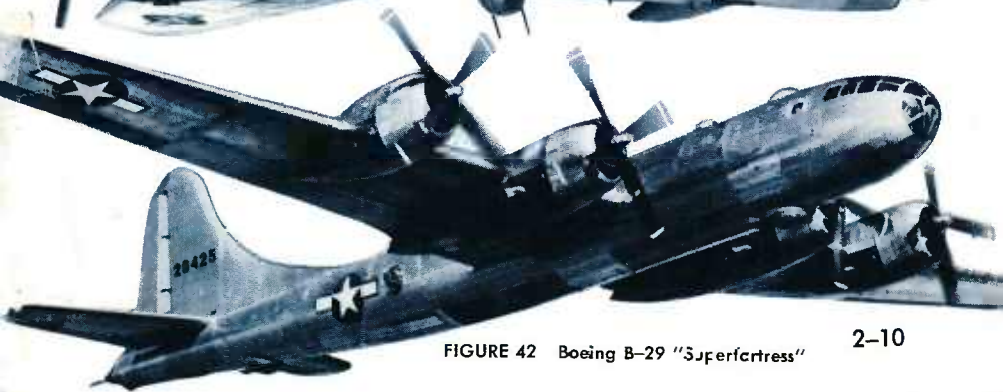

FIGURE 42 Boeing B-29 "Superfortress"

bility. Maneuverability was its greatest asset, because its speed was not too impressive (370 mph, MkIIA), its combat range was 395 miles, and its service ceiling 31,900 feet.

The *Hurricane* was a larger fighter to which auxiliary gasoline tanks could be attached to place its maximum range at 920 miles. In overall performance, the *Hurricane* was superior to the *Spitfire* because of its versatility as both fighter and bomber, extended ranges, and capability to carry heavier armament.

In the twin engine bomber class the most outstanding British product of WW II was the *DeHavilland Mosquito*. This aircraft saw service in the heartland of Germany because it could outrun most German fighter aircraft with a top speed of above 380 mph and long range, which varied from 1,560 to 2,180 miles according to model.

The British four engine *Lancaster* heavy bomber was placed in service late in 1941. With a bomb-carrying capacity of 22,000 pounds, the *Lancaster* carried mass destruction to occupied France and to Germany. This aircraft was reported to be practically too easy to fly. Its response to control pressure was immediate and smooth, so much so that many pilots took it through loops and other maneuvers not intended for heavy bombers.

World War II had been going on for over two years before the U.S. officially got into the fray. Our hottest production fighter in the early months was the *Curtiss P-40*, which received much criticism. However, the *P-40's* ability to fly at 357 mph and as far as 1,400 miles without refueling led it to see service with U.S. and Allied forces on all fronts.

Production of new types and great numbers of aircraft accelerated rapidly as World War II progressed. Fighters, medium bombers, and heavy bombers rolled off the assembly lines by the hundreds. Old models were improved and new models produced as technology advanced. So many different types of aircraft were produced that it would be quite impractical to discuss them here, but we can cite a few examples.

The *P-51 Mustang*, according to many authorities, came out on top as the most efficient U.S. fighter aircraft. It could fly an impressive 437 mph at 25,000 feet, had a range of 2,300 miles (with auxiliary fuel tanks), and could climb to 41,900 feet.

Fame was accorded the twin engine *B-25* when General "Jimmy" Doolittle and his raiders used carrier-based *B-25s* to bomb Tokyo. This aircraft was named the *Mitchell* in honor of General Billy Mitch-



FIGURE 43 Messerschmitt  
Me-262

ell—the pioneer of American airpower. The *Mitchell* was capable of carrying a bomb load of 5,200 pounds and flying 285 mph; therefore, it was used in all theaters and for almost every tactical situation. Some models included defensive turret guns located in the nose, upper fuselage, and tail; for offense, it had fixed nose guns including, on one model, a 75mm cannon.

United States four-engine heavy bombers were the famous *Consolidated B-24 Liberator*, *Boeing B-17 Flying Fortress*, and the *Boeing B-29 Superfortress*.

The *B-24* could fly 300 mph, and carry its bomb load more than a thousand miles to the target and return. It was the *B-24* which had the widest use as a four-engine bomber during WW II.

After many deficiencies had been corrected, the *B-17* became the principal destructive force used against Germany. Pilots liked this aircraft because it was easy to fly, would take tremendous punishment from fighters and flak, and had a range double that of the *B-24*.

For the specific purpose of bombing Japan into submission, the *B-29 Superfortress* was built, but it was not until 1944 that the aircraft first saw combat. The *B-29*, a long-range strategic bomber, dropped atomic bombs on Hiroshima and Nagasaki, and was therefore instrumental in bringing about Japan's surrender and the end of World War II. The *B-29's* ability to fly high and deliver a large bomb load kept it in USAF service until 1960, when it was finally phased out of service.

Before we conclude the development of airplanes and airpower in World War II, we must return to Germany, our starting point. It was here that the basis of present-day jet and rocket vehicles got their greatest boost, and it was because the Nazis were working desperately to devise methods by which they could turn the tide of war in their favor and realize their dream of vast conquests.

Messerschmitt's *Me 262* twin engine jet fighter was the world's first operational military jet plane—even though Heinkel built and flew the first jet in 1939. Had the *Me 262* been placed in service much earlier than 1944, the Luftwaffe might have maintained air superiority and allowed Germany to win the war. The *Me 262* could reach its maximum speed of 519 mph at sea level and could attain 542 mph at

19,686 feet—better than anything the Allies had.

Also, the German high command let another opportunity slip through its fingers when it failed to recognize—until too late—the awesome potential power of rocket weaponry. Solid fuel rockets (sky-rocket types) had been employed in warfare by the Chinese as early as 1232 A.D., but serious use of rockets had to wait until the second world war. Rocket projectiles were in use by the Allies before the end of WW II, but the major weapons were the shoulder-launched “Bazooka” anti-tank rocket, the multiple barrage launchers (fast-firing artillery, without pinpoint accuracy), and relatively small air-to-air and air-to-ground rockets—launched from airplanes, of course.

Germany, however, was the first to apply rocket power to propel an aircraft and to develop long-range rocket missiles. The Messerschmitt *Me 163 Komet* had only a few minutes fuel to thrust her to combat altitude. Afterwards the pilot had just enough time to make one combat run and glide back to earth.

The greatest success with rocketry came with the liquid-fueled V-2, the forerunner of today’s missile and space vehicles. Before the end of WW II, Germany’s V-2s were destroying targets 230 miles from their launching sites. Both the United States and Russia captured V-2 hardware, German rocketry experts, and futuristic plans for improvements, and thus laid the foundation for their own progress in military weaponry and space exploration.



FIGURE 44 Messerschmitt Me-163



FIGURE 45 V-2



FIGURE 46 General Dynamics F-111

## CONTEMPORARY MILITARY AIRCRAFT AND MISSILES

Beginning with one fragile, barely flyable airplane developed less than 70 years ago and with the impetus of two World Wars, we now have hundreds of different types of military aircraft and rockets. Each has different capabilities according to its design.

Some aircraft fly from aircraft carriers; others are amphibious (they can “land” on water or land), but most are strictly landplanes. They are classed as fixed wing, variable-sweep wing, rotary-wing (helicopters), folding wing (carrier-based aircraft), vertical take-off and landing (VTOL), and short take-off and landing (STOL). They are specialized as fighters, bombers, reconnaissance types and transports. Missiles make up part of the picture too, and again we find there are many types.

So where do we start? It would take many volumes to give a comprehensive coverage of just contemporary military aircraft, and this we cannot do; we can give only a brief glimpse at some of them.

**FIGHTERS.** Fighters have evolved from the now primitive *P-51* into jet-propelled supersonic (faster than sound) weapons systems. They carry nuclear devices that can devastate entire cities. They may be armed with air-to-air rockets that knock enemy craft from the skies by seeking them out with self-contained tracking devices. Fighters may be armed with conventional bombs to be employed in tactical combat situations such as bombing the enemy’s supply routes or destroying his troops on the front lines.

The United States Air Force’s *F-111* type is an example of contemporary military aircraft. With the ability to vary the position of its wings in flight, the *F-111* serves as a versatile warrior. When its wings are in full extended position, it is capable of flight slow enough to allow it to land on relatively short landing strips—to include aircraft carriers. It attains high speed (Mach 2.5 or about 1500 mph) capability when the wings are maneuvered into the full sweepback position.

Higher flying and faster aircraft develop as technology develops, and each new one must go through several phases before it is placed in service. Such is the case with one of the most advanced airplanes currently in the USAF inventory. This is the *SR-71* which reaches speeds of Mach 3 and altitudes above 70,000 feet. *SR-71* is the designation for the reconnaissance production model; yet the vehicle can be used as a long-range interceptor, or fighter, with structural modifications made especially to adapt it to this purpose.

It is rather difficult to say that any one airplane is limited to the role of a fighter, or bomber. With tremendous thrust power, even the smallest airplane can be a multipurpose weapon.

**BOMBERS.** Aircraft with the sole mission of dropping bombs may have an indefinite future. However, the United States Air Force's *B-52 Stratofortress* is a classic in the bomber, or strategic bomber, category because of its capability to range far into the enemy's territory and obliterate his industrial complexes. NOTE: Strategic bombing is the term applied to the destruction of an enemy's weapons-producing industrial complexes and transportation systems deep within his homeland.

The technique of strategic bombing had been perfected through the employment of *B-17s* and *B-29s* during WW II. From the *B-29* there evolved the huge *B-36* with its six pusher-type engines and intercontinental capability. But the *B-36* was soon replaced by the all-jet *B-52*—still a potent deterrent in our aerospace arsenal. The *B-52* may continue in service for some years, since it can fly 630 mph at 40,000 feet and has an *unrefueled* range of 12,000 miles.

With the development of long range radar detection devices it was necessary to produce a bomber vehicle which could fly under radar screens and be upon the enemy before he realized it. The *B-58 "Hustler"* was designed for this purpose, and played a great part in our nation's war-deterrent force until 1969, when it was phased out of the USAF inventory. This does not mean that the *B-58* tactic was phased out too; it means that other new types can do the job more effectively.

FIGURE 47 Lockheed SR-71



FIGURE 48 Boeing B-52



FIGURE 49 Boeing B-36



**STRATEGIC AND TACTICAL RECONNAISSANCE AIRCRAFT.** Aircraft serving in these categories most often use photographic means to gather information about a potential aggressor or an enemy. Strategic reconnaissance is concerned primarily with permanent installations deep inside enemy territory, and may be accomplished by aircraft such as the *SR-71* discussed above. Tactical reconnaissance is the gathering of information in or near forward combat areas. Information about the enemy's troop and materiel movements is an example of tactical reconnaissance.

The *RF-4C* now serves as one of the several tactical reconnaissance types for the USAF. At 1,000 feet it can fly at an impressive 950 mph; at 48,000 feet it can attain speeds up to 1,485 mph (Mach 2.25).

**ATTACK AIRCRAFT.** This is a military classification given to aircraft used for low-flying bombing and strafing attacks. It is difficult to point out a specific attack aircraft since many in the fighter category



FIGURE 50 Consolidated B-58 "Hustler"

FIGURE 51 Grumman  
S-2 "Tracker"



FIGURE 52 Grumman A-6 "Intruder"



FIGURE 53 OV-10A



FIGURE 54 UH-1 "Huey"



FIGURE 55 CH-47A  
"Chinook"



can serve this purpose. The *Grumman A-6 "Intruder,"* however, was designed specifically as an attack aircraft for the U.S. Navy.

The *A-6* first saw combat in Vietnam in 1965, flying from the U.S.S. Independence. It can fly 685 mph at sea level and carry a 15,000-pound ordnance load which may include tactical nuclear weapons.

**PATROL AND ANTISUBMARINE WARFARE (ASW) AIRCRAFT.** These are primarily the concern of the United States Navy, but we should cite one type which has been in service for several years. The *Grumman S-2 "Tracker"* has the distinction of being the first carrier-based aircraft capable of performing all phases of the ASW mission: detection, classification, and destruction. In addition to its highly complex submarine detection system, the *S-2* may carry homing torpedoes, depth bombs, and depth charges. The *S-2* is not fast by the jet standard, but its two 1,525 hp radial engines can pull it along at 280 mph.

**COUNTERINSURGENCY (COIN) AIRCRAFT.** This is a relatively new classification that has been developed or especially adapted to combat the supposedly new tactic of international communists—the instigation of guerrilla warfare insurgency to violently overthrow a government; hence, the need for counterinsurgency aircraft. Various types of propeller-driven aircraft of WW II vintage still are used in counterinsurgency operations.

One aircraft developed by the United States especially for COIN is the *OV-10A*. It serves as a combination forward air control (FAC) and observation craft, and at the same time, performs light attack missions. The *OV-10A* can reach 305 mph when flying at sea level. Its turboprop engines and 30-foot wingspan allow turns within a 500-foot radius, and the 3,270-pound ordnance capability can vary according to the mission.

**HELICOPTERS.** Helicopters have had varied military service since the first experiments in using them as weapons took place in 1942, but their present-day use as gunships for "small war" or counterinsurgency operations has "upped" their status as military weapons.

One example of the combat helicopter is the *Bell UH-1* series. The "*Huey*," as the basic design is called, may take several sub-names according to its armament and design modifications. In any event, the helicopter has taken on light attack missions and defensive missions in support of the larger troop-carrying "choppers" such as the *CH-47A "Chinook."*

FIGURE 56

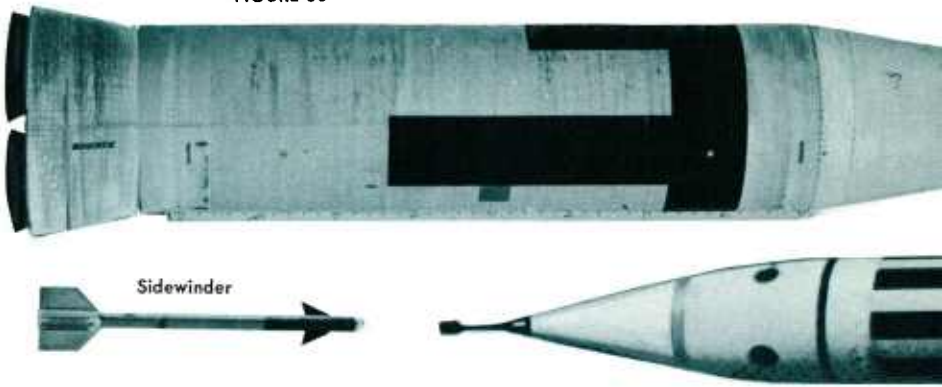

FIGURE 57



As time goes on, more advances will be made in helicopter design and capability. As improvements are made, the military will no doubt assign greater tactical and transport roles to helicopters.

**ROCKET MISSILES.** Rockets have become one of our prime defensive forces and deterrents to the aggressive intentions of potential enemies. Gone are the days when troops and materiel in rearward positions would be beyond the range of artillery or even aircraft. Missiles are capable of reaching deep into the enemy's territory, no matter how far, to deliver nuclear weapons to obliterate vast supply caches and troop concentrations.

Minuteman



Pershing



Hound Dog



Nike-Hercules

Rocket missiles are augmenting and replacing conventional "shot and powder" weapons in all military services and in almost all use classifications. Machine guns and machine cannons on aircraft are augmented by *air-to-air missiles*. Artillery missions may be accomplished by *surface-to-surface missiles*. Enemy aircraft and missiles will encounter *surface-to-air missiles* When it is necessary to use pinpoint accuracy against an enemy ground installation and when it is tactically advisable to destroy the installation from some distance, *air-to-surface missiles* are used.

Within each classification, several types of missiles appear and vary according to their specific purpose. It is not our intent to qualify you as a missileer, but it should help your overall understanding of missile weaponry if we present at least one example from each of the classifications.

The "Sidewinder" *air-to-air missile* is used by one airplane to destroy another. The missile's infrared detection system "locks" onto the heat generated by the target's propulsion system and guides itself to

the target. This is a vast improvement over the old machine gun devices used in WW II—depending, of course, on whether one is the sender or receiver!

The *surface-to-surface missiles*, as we have indicated, are extensions of artillery. One example is the U.S. Army solid-fuel *Pershing*. The *Pershing* is a ballistic rocket missile with the capability of traveling up to 460 miles to reach its target. It can be armed with either conventional explosives or a nuclear warhead. Note: when we say “ballistic,” we mean that the missile is guided over part of its trajectory, and that from the point where the warhead separates and falls to the target in the last stages of flight, it performs just as does a ballistic artillery shell.

Intercontinental ballistic missiles are also *surface-to-surface* missiles, and follow trajectories in the same manner as the *Pershing*.

The solid-fuel *Minuteman* is a good example of this type, especially since it is the principal deterrent missile weapon in our arsenal. The *Minuteman* reaches into space, and its inertial guidance system keeps it on a proper trajectory for its warhead to reach a target as far away as 6,300 miles.

*Orbital and fracto-orbital* missiles, although launched from the surface to strike the surface, are somewhat out of the category of surface-to-surface missiles. Whether or not orbital missiles exist is questionable, because, if they do, the “owning nations” would not like the fact to be known. Anyway, there is no lack of technical know-how to place a warhead-carrying rocket into earth orbit and leave it there until the need or desire to use it arises. Then, the rocket could be retrofired and caused to leave earth orbit, enter the atmosphere, and be guided to its target by a guidance mechanism that had been preprogrammed.

On the other hand, fracto-orbital missiles do not go into orbit, but are fired so that they approach orbital speeds to travel great distances through near-earth space. Then they can be retrofired to re-enter the atmosphere and be on their way to surface targets. The advantage of fracto-orbital missiles is that they can be fired from and descend upon the target from any direction. This allows the sender to circumvent heavily defended approaches to the target.

*Surface-to-air missiles* now vary from the small, shoulder-launched *Redeye* to the *Nike* series. The *Redeye* is a heat-seeker which infantry troops may use against low-flying enemy aircraft. The *Nike-Hercules* is an anti-aircraft missile that is guided to its target at heights above



FIGURE 58 C-5A "Galaxy"

(and below) 150,000 feet. Variations and improvements in the *Nike* type form one of our nation's countermeasures to intercontinental missile attack.

The *Hound Dog* is an example of *air-to-surface missiles*. The pilot of a high-flying aircraft may proceed to within 700 miles of his intended target, launch the Mach 2-speed *Hound Dog* missile, and be well on his way to home base before the target is destroyed.

**TRANSPORT AIRCRAFT.** Though not as glamorous as sleek fighters, bombers, and missiles, the aircraft built especially for transport service are essential to military operations. Without the means to transport material and men rapidly from one point to another, a nation would be able to make only limited use of strategic and tactical aircraft because the supplies and men that support them would depend on slow surface transportation.

The largest transport in the world is the USAF's fanjet powered *C-5 Galaxy*. This is the predecessor to future transports already under study that will be even larger and faster. The *C-5* can load as much as 220,000 pounds and then fly as far as 3,500 miles without refueling.

Another jet transport in wide service is the *C-141 Starlifter*. It can carry a maximum payload of 60,000 pounds 4,600 miles at speeds up to 550 miles per hour.

These examples, the *C-141* and the *C-5*, are only two of the transport types in use. The military services also use transports that are propelled by piston engines, and the number of engines may vary from two to four. Jet-powered transports are not all the four-engine type; many have twin engines. Whatever type the transport may be, it has certain capabilities that are best suited for a particular job or jobs, and this is a truth pertaining to all types of airplanes and rockets, whether military or civilian.

FIGURE 59 C-141 "Starlifter"



# CHAPTER 3



FIGURE 60

CIVIL AVIATION

Civil aviation includes all aircraft that are not part of either the military forces or what are considered public aircraft. Public aircraft are those that are operated by any governmental echelon, whether it be federal, state, county, or city. Examples can be found in the Federal Government with Federal Aviation Administration airplanes. Below federal level, governmental echelons use aircraft to make surveys, control crime, monitor automobile traffic, etc.

From the one Wright Brothers experimental airplane, civil aviation has grown to nearly 155,000 aircraft today that travel millions of miles each year. And, like the military, these civil aviation aircraft are designed and built to perform special functions. The smallest are used for pleasure flying, light cargo transportation, passenger flights, crop dusting, patrolling, and instruction. Intermediate twin-engined ships may fly passengers or cargo on relatively short trips. The large three- and four-engine jet or two- and four-engine propeller-driven aircraft make flights that take passengers or cargo great distances.

### CIVIL AVIATION CATEGORIES

All civil aviation is divided into two main categories: General Aviation and Civil Air Carriers.

**GENERAL AVIATION.** General aviation is the *largest* user of civil aircraft in the United States. Although the number may fluctuate from year to year, we can say that general aviation will grow steadily for many years. There may come a time when the airways are supersaturated with aircraft, and even the smallest aircraft built will have to fly under strictly controlled conditions. If that should happen many people would cease flying as pilots and rely on the airlines to provide their "flight time." This situation is unlikely for two main reasons: (1) not everyone likes to fly, and (2) the nation would have to be highly overpopulated to "run out of airspace." So we have plenty of airspace for many more airplanes and pilots, and all of us who can may still join all those many others who take to the airways for fun or for profit.

FIGURE 61 Piper "Cherokee"

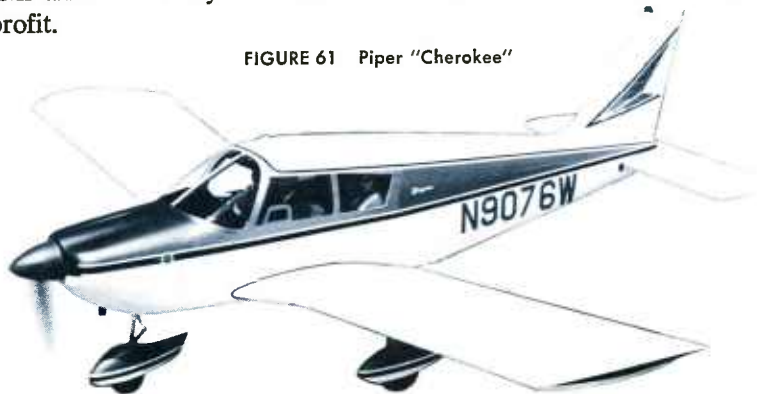

FIGURE 62 Aero "Commander"



Within the general aviation category are several types of flying, and we shall discuss them briefly:

*Pleasure flying* involves the largest portion of general aviation activity. Single engine aircraft, such as those produced by Cessna and Piper aircraft corporations, are the most popular with pleasure flyers. This is because the smaller aircraft are the least expensive, and their cost-per-hour of operation is modest.

If you observe closely the activities at any nonmilitary airport, you will see all types of people in all types of light aircraft going up for the pleasure of flying. Most of the aircraft will not be new. A small aircraft that has superior care can be airworthy and attractive for many, many years. Also, the real enthusiast, or "airplane nut" as he is sometimes called, takes great pleasure in refurbishing an older aircraft or building his own.

*Business flying* comes in many forms and may use aircraft ranging in size from the small single engine up to multiengine types. Industrial and business enterprises have realized that there is profit in the rapid transportation of their administrative, technical and sales personnel. Some of the larger companies now own a fleet of aircraft and employ personnel to fly and maintain their aircraft. Smaller businesses may own only one small 4-place airplane, and employ a pilot who is capable of performing some other job for the business when he is not working as a pilot.

Patrol and survey flying are also flying activities that are considered part of business flying. Businesses that have power lines, pipe lines, or extensive land holdings which need to be checked or patrolled now use light, slow-flying airplanes to do these jobs because they are much faster than land vehicles or horses. Survey flying involves mapping, mineral prospecting, the study of wild life populations, hunting of predatory animals, and so forth.

*Commercial flying* is the classification given to all flying that is done on a "for hire" basis. Commercial flight operations may involve the

transportation of passengers and cargo, but you should not confuse this type of operation with civil air carrier (airline) operations which also transport passengers and cargo. The transportation of passengers and cargo which comes within the phrase "commercial flying" is done with the larger single engine and light twin engine aircraft and helicopters.

Both aircraft and helicopters are now used in commercial flight operations that involve the application of insecticides to crops. The art of "crop dusting," as this operation is usually termed, has become a very specialized business. Whereas older bi-planes and small Piper "cubs" were at first adapted to crop dusting, the demand for this service and the need for improved techniques spurred manufacturers to build specially-designed aircraft. Within the fuselage of these specially-designed "crop dusters," much larger tanks were placed to contain insecticides. More powerful engines and other refinements make modern crop dusting operations safer and more efficient.

Instructional flying represents flight training of civilians under an instructor's supervision whether the instructor is in the aircraft (dual) or the student pilot is flying by himself (solo). Most instructional flying is done in single engine aircraft by those who are working toward their private pilot certificate.

**U. S. CIVIL AIR CARRIERS.** So much terminology is involved with descriptions of civil aviation activities that it is sometime difficult to understand just what is being discussed. This is true with U.S. Civil Air Carriers, or those companies formed for the specific purpose of carrying passengers, cargo, or both. Any company doing this work as its only function is an air carrier, but is commonly referred to as an *airline*.

If an airline conducts its business within the conterminous United States, within Alaska, or between the islands of Hawaii, it is considered a *domestic carrier*. Those airlines which operate between the United States and foreign countries, or which fly over major expanses of international waters or any foreign territory are considered international/territorial carriers. For example, an airline which has Puerto Rico as its only service point outside the conterminous U. S. would be an international/territorial carrier because its aircraft fly over a major expanse of international waters; the same would be true of an airline which flies over Canada to reach Alaska.

*Supplemental carriers* serve to fill the gaps left by both domestic and international/territorial carriers in cargo and passenger transport-

tation. Many supplemental carriers earn a large portion of their revenue by contracting to the U. S. Government to fly military personnel and equipment within the United States and to foreign countries. Therefore, a supplemental carrier may be involved in either or both domestic and international/territorial carrier operations.

Now let's look at the further breakdown of domestic carriers: If an airline flies between major cities within the United States over a specified route, it is a *domestic trunk* airline. For the transport of passengers and cargo from large cities to smaller communities, *local service* airlines fill in to make a rather complete network of air transportation. The very latest additions to this air transportation network are the smaller aircraft and helicopters used as various types of air taxis in certain major cities where passengers may need rapid transportation from one airport to another to connect with another airline that is to carry them on to their destinations. Where this air taxi service is available, it is no longer necessary to depend upon slow and uncertain surface transportation which all too often may cause air passengers to miss their scheduled flights.

## THE AIR TRANSPORT INDUSTRY

All activities that involve transporting passengers and cargo by air are part of the air transport industry. This industry has grown rapidly in a little over forty years from a point of nonexistence to gargantuan status in our national economy. Air transportation will continue to increase in the future as new aerospace vehicles and larger transport airplanes are built. Also, as the need for transportation between communities develops further, the air taxi or commuter service airlines will increase and add to the industry.

The air transport industry transports all types of cargo. Today there are very few products that cannot be transported by air. Even huge rocket components, such as the Saturn launch vehicle, are no problem. Buses, trucks, and boats may be sped to their destinations by air. Heavy machinery needed quickly in some remote part of the world can be there within hours instead of the weeks required only a few years ago. No longer can our society do without the air transport industry.

Let's take a look at some of today's air transport aircraft. There is a growing trend toward greater utilization of all-jet powered airplanes, but the "prop jobs" will be around for our lifetime and longer. The Con-

vair 600, with its two turboprop engines, is one type especially suited to short haul transportation. This aircraft can fly a respectable 312 mph, and carry up to 40 passengers.

Boeing Aircraft's 727 is an example of the all-jet short/medium-range transport. Her three turbofan jets permit a passenger payload of 131. This number of passengers can be transported 1,700 statute miles traveling at speeds up to 600 mph (when at 25,000 feet).

In the larger and long-range classification of jumbo jet transports, the Boeing 747 was the pioneer. In its all-economy configuration (that is, without "first class" accommodations) the 747 can transport 490 passengers. With these 490 passengers, the 747 can cruise 625 miles per hour at 40,000 feet, and travel the intercontinental distance of 4,600 miles.

The supersonic transports (SSTs) promise to further revolutionize the air transport industry. The number designation 2707 was given to Boeing's SST design. Although Congress stopped construction of the prototype in early 1971, when and if the Boeing SST is built, it will fly slightly over 2,000 mph while at altitudes above 60,000 feet. This will be an astounding advancement over the 220 mph airline transports of 1939, and will exceed the performance of the British-French Concorde and the Russian TU-144. And, we can safely say that the future will bring even more breathtaking accomplishments.

So the trend leads us to believe that more and more goods and people will be reaching their destinations by air in future years, and that the air transport industry will grow. This is not the complete story, however. There is much more involved than just the flight portion of the air transportation story. It takes the cooperative efforts of many thousands of people working in the operations offices, traffic offices, and the air carrier maintenance and repair stations to keep the air transport industry going.

Passenger and cargo space must be sold. Reservations must be made. Passengers and baggage must be loaded promptly. Cargo must be stowed properly in the aircraft to maintain balance. Navigators must plot the courses to be flown, flight engineers must monitor the aircraft's performance, and meteorologists must observe and forecast weather conditions.

Communicators give pilots in-flight data essential to a safe flight. Before dispatchers authorize flight departures, they insure that all required conditions are met by the pilot, his crew, and his aircraft. Public relations personnel help the general public to understand air-carrier

FIGURE 63 Convair 600



FIGURE 64 Boeing 727



FIGURE 65 Boeing 747



FIGURE 66 Concorde SST

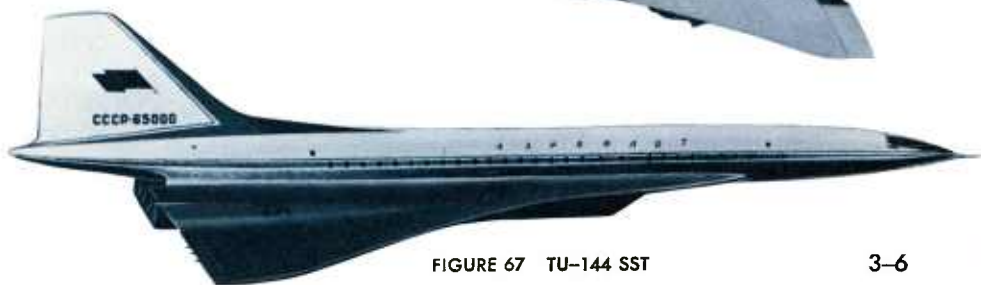
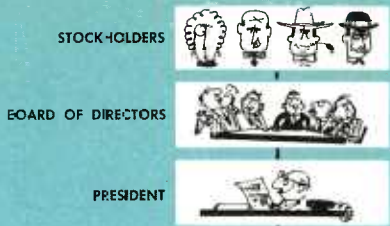

FIGURE 67 TU-144 SST



**GENERAL AIRLINE ORGANIZATIONAL CHART**  
 (FUNCTIONS SHOWN REPRESENT ONLY 30% OF ACTUAL FUNCTIONS!)

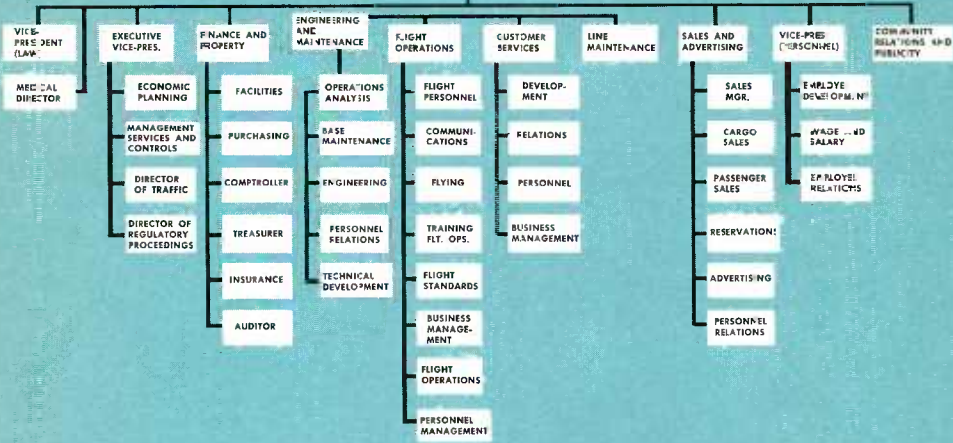

FIGURE 68

service and the benefits of air transportation. Agents at every airline terminal sell tickets, and check in passengers before flight departure time. Additional services are provided by legal counselors, instructors who train pilots and mechanics, and accountants who keep financial records.

Maintenance is one of the most important of all support operations in the air transport industry, and a program of continuous maintenance is followed by all airlines. The details of maintenance programs vary between airlines, but an average of 19 maintenance hours are spent on an aircraft for *each* hour it is in the air. All airlines see that their aircraft are checked before they depart on a flight; all conduct daily or "turn around" inspections of equipment. One company rebuilds one fourth of an airframe after each 3,000 hours of flying time. After 12,000 hours and the rebuilding of the last section, the entire airframe has been rebuilt.

Engines are rebuilt after a specified number of operating hours. Depending on the type of engine, this complete rebuild will come when the engine has logged between 600 and 2000 operational hours. All of this is not to say that an airframe, powerplant, or instrument is completely rebuilt from the "ground up." Parts that are serviceable are re-

tained for continued use, but each part is checked for wear or fatigue to see if it comes within specified safety tolerances. If it does not meet the tolerance standards, it is replaced.

An aircraft's instruments are also given close attention. Some instruments are carefully overhauled and continued in service. On the other hand, certain instruments are replaced after service for a specified number of hours; this is done even if inspection finds them to be functioning properly.

The maintenance function is to serve one main purpose: the safety of the user public, and it has succeeded. Believe it or not, travel by air is the safest of all modes of transportation.

As a further assurance to the user public that air transport and other aviation activities are safe, maintenance personnel must be certified as competent by the Federal Aviation Administration (FAA). In other words, a person may be an expert automobile engine mechanic but he would not be allowed to work alone on an aircraft reciprocating engine. It takes study and work, either in a school or on-the-job training, plus successful completion of an examination, before the FAA will certify a maintenance specialist as competent.

To the casual observer at a repair hangar or station, the situation might seem one of utter confusion, but this is not the case. Actually, the processes are orderly, and each group of technicians has specific tasks to perform. For example, one group removes the engines; another group removes the engine accessories; another group transfers the engines and accessories to repair stations where still another group of technicians will make necessary repairs. While these activities are under way, airframe mechanics are inspecting and repairing the fuselage, wings, and empennage; other technicians are busy at repair stations or within the airframe going over the propellers, electrical system, hydraulic system, flight instruments, landing gear, etc. So you can see that it takes many different specialties just to maintain the airplane, and each of these must have FAA certification.

## REGULATION OF CIVIL AVIATION TRAFFIC

There is a lot of air space in which aircraft can fly, as we have mentioned, but all must converge at a destination—or airport—and the airways between these destinations become relatively crowded. The regulation of ever-growing civil aviation traffic and of military air traffic is of utmost concern to the United States Government.

Even as early as 1926, the Federal Government saw the need for regulating aircraft flight. But it was aircraft operation during WWII that brought about faster, larger, and more numerous aircraft and a rapid expansion of airline activity immediately following the war. The increased activity made quite obvious the need for increased Federal control over air traffic operations.

Today this is another responsibility of the Federal Aviation Administration. (See Chapter Seven.) In fact, it is generally true that FAA controls all facets of flight activities, beginning in the stages of design and extending through flight operations.

In 1958, when the Federal Aviation *Agency* became the Federal Aviation *Administration* with increased responsibilities, its first task was to divide the crowded airspace equitably between military and civilian users. The FAA restored to civilian use large tracts of airspace that had been restricted to military use. It also directed that other airspace reserved for intermittent military tactical purposes be used by civilians when it was not needed for military operations. Both of these rulings relieved somewhat the ever-increasing air traffic congestion, yet the sensible regulation of safe air traffic enroute to and from airports will continue to present challenges.

FIGURE 69



**AIRWAYS.** Visualize the sky above the United States as being divided into three-dimensional freeways, freeways that connect cities and towns just as do our state and national highway systems. These freeways of the sky, or airways, are what pilots use to travel the long distances referred to as cross country flights.

Each airway takes up its portion of the 250,000 miles of the Federal Airways System, and we can consider the airways as sort of square tunnels in the air through which aircraft fly. The low altitude airway has a floor that is uneven because it starts at 1200 feet above the surface. When a low altitude airway crosses an obstacle in its path the airway floor is considered to rise 1200 feet above the highest point of that obstacle. The width of the low altitude airway is eight miles, and its ceiling is 18,000 feet.

Another "road" system overlies the low altitude airway; this is the high altitude airway system. It begins at 18,000 feet, and extends upward to 45,000 feet. Again these airways are eight nautical miles wide. Above 45,000 feet, the airspace is reserved for point-to-point flights on a random routing basis. In other words, anyone who has an aircraft that can fly at this height need not fly the route of underlying airways, but we might add quickly that few civil aviation aircraft now in use have need for flights at such altitude. (SSTs will present new problems.)

Like the highway systems, the airway systems have their versions of signs or directional guides. The pilot uses a navigation chart (map) which depicts the invisible airways, the terrain features beneath them, and the locations of electronic navigational aids. The basis or backbone of navigational aids (NAVAID) is the very high frequency omnidirectional range radio station (VOR). Each VOR station sends out 360 separate radio courses (radials) from its location, along with its identification—either in recorded Morse Code, voice, or sometimes both. Normally, the pilot plans his flight to include these VOR stations as points along his route; then he tunes his radio receiver to the frequency of the station he will first encounter, and follows the signal. If the VOR station is located at his destination, he will, of course, land, but if the station is one of several along his route, he simply flies over it and tunes to the next station.

Another navigational aid used extensively by the military is TACAN (Tactical Air Navigation). This NAVAID broadcasts on ultrahigh frequency, but it additionally assists both military and civilian pilots by providing a signal that is received by distance measuring

equipment (DME). Thus the pilot can tell how near he is to the station.

The Federal Aviation Administration has collocated many VOR and TACAN stations which are designated by the acronym VORTAC. A civilian pilot who has DME equipment can get a distance reading from these stations.

Flight Service Stations (FSSs) provide vital information to pilots both inflight and preflight. Each of the stations is responsible for covering an area of 400 miles, and they are staffed by FAA specialists who are familiar with the area terrain. The FSS specialists provide information such as area weather, special terrain features, suggested routes and altitudes, and any other information that may be important to a pilot.

All of these aids are for the pilot's use in finding his way, but at the same time the FAA has means of monitoring his flight through the airways. This is done by FAA air route traffic control centers (ARTCCs) for pilots who file instrument flight plans. There are twenty of these centers placed strategically across the nation, and each handles traffic within its own area. Using radar and communications equipment, air route traffic controllers know the positions of aircraft

FIGURE 70

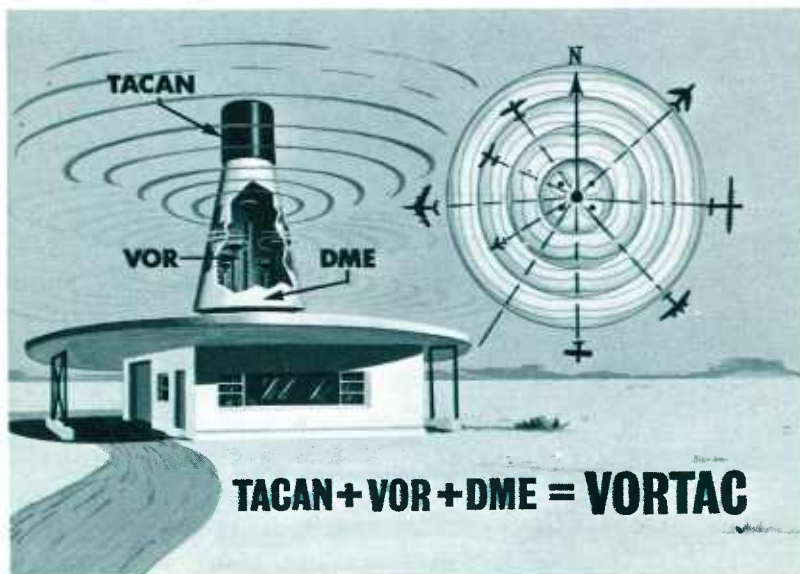

within the area, and can instruct pilots to change course or altitude when necessary. If a pilot's flight path takes him into an adjoining ARTCC area, the losing center transfers control to the gaining center, and the flight is kept under surveillance in this manner until the pilot reaches his destination.

**AIRPORTS.** As of now, airports are of greatest concern to those who have the responsibility of insuring the safety of flight operations. Again, it is the FAA which has this responsibility. Aircraft have plenty of "elbow room" as they traverse the airways, but when they approach the larger airports, pilots realize the similarity to a freeway entering a large city: one must slow down and look for directions. The pilot enters airport control areas and control zones as he nears the airport, and reports to the airport's air traffic controllers. If traffic is heavy, the controllers might direct him to a "parking space" to await further instructions. Actually the parking spaces are holding points at which the pilot flies in an oval pattern at an assigned altitude until he can be sequenced into the "downtown" traffic safely.

Again, navigation aids and surveillance devices are used within the airport's control area. FAA's airport surveillance radar (ASR) can establish the location and bearing of aircraft within 30 miles. The air traffic controllers use this information to instruct pilots by radio so that aircraft within the control area may be spaced at safe intervals.

Precision approach radar (PAR) tells air traffic controllers if an airplane is making a normal descent and if it is lined up with the runway. Corrective instructions are radio-relayed to the pilot.

To help the pilot during his final approach to the runway, several other aids are used. Aircraft so equipped may use the instrument landing systems (ILS). This highly precise guidance system gives the pilot vertical and lateral guidance in landing during adverse weather conditions.

When visibility is poor, a system of lights known as the approach lighting system (ALS) helps the pilot flying by instrument flight rules (IFR) to make the difficult transition from his instruments to flying by visual reference to the ground. Included in the ALS there may be sequenced flashing lights (SFLs) which give the illusion of motion and literally point to the runway. The SFL is even more effective than the ALS since its high intensity lights coupled with sequence flashing are quick to attract the pilot's attention as he descends, say, out of a cloud bank.

You should not get the impression that all airports have the most modern equipment and that every flight is monitored. This is not the case. As you probably know already from observation or reading, there are many airports that have neither a control tower nor a lighting system. Also, all pilots do not fly in the FAA controlled airways, and therefore, are not monitored. You will get more complete coverage of these subjects when you study other aerospace education texts in the series published by Civil Air Patrol.

## THE AEROSPACE MANUFACTURING INDUSTRY

Civil aviation, government aviation, and military aviation would not exist were it not for the talents and skills of the people who work in the aerospace manufacturing industry.

In the early days of airplane manufacture, companies existed to build airplanes, and airplanes were their only product, but times have changed. The speed and uses of airplanes and rockets have grown, and many complex components are necessary to the manufacture of modern aircraft and rocket systems. At one end of the spectrum some companies build airplanes as their only product; at the other end, there are large industrial conglomerates so diversified that they produce television sets at one location, rocket or jet engines at another, and components for satellites at another. In the interest of simplicity, all these companies, whether they are building light airplanes or huge rockets, are now considered to be part of the aerospace manufacturing industry. You will also hear it called simply The Aerospace Industry. It is referred to below sometimes as "the industry," but it encompasses many different enterprises engaged in countless research, development, and production activities.

Present-day aerospace manufacturing for both civilian and military purposes has increased so rapidly and become so complicated that it requires more and more specialization. Technology, tooling, and personnel required to produce even *one* component for an airplane or rocket must far exceed yesteryear's standards, and it is no longer the rule that one industrial complex tries to build, or even assemble, all components of an advanced vehicle, such as the Saturn/Apollo space vehicle. Projects of this magnitude require the combined efforts of many separate companies and government agencies.

A few companies restrict their operations to the manufacture of light airplanes, as we will discuss in the next chapter, but, even so,



FIGURE 71

many of the components they use are manufactured by other companies.

Whether an industry is building toys, automobiles, aircraft, or a lunar module, there are basic processes common to all. At the very outset, there must be a *need* for the product. We use the term "need" very loosely, because the need may have been generated by national goals of international and scientific importance, such as placing astronauts on the moon and Mars. Man's competitive spirit and inherent thirst for knowledge will always create a need for exploring the unknown here on Earth and beyond, but certainly he could exist without exploring other celestial bodies.

Man cannot exist, however, in the civilized state without being a consumer. By inventiveness and advertising, manufacturers of hundreds of consumer products, such as airplanes, automobiles, and toys, create need for new models and types. Potential customers first want a highly advertised product because of its beauty or performance specifications, rationalize the "want" into a need, and then buy. If they have the means, customers seldom purchase only what they actually *need* to sustain life, perform work, and so forth. In this respect, "want" and "need" become synonymous.

Before a manufacturer can advertise his product, he must first decide what specific purposes it must serve, and how it must perform to fulfill the need. The new product, or new model, first takes shape, figuratively, in someone's mind, and then a development project is given to design engineers who decide the product's contours, or actual shape. In the case of an airplane, this shape will depend on the airplane's ultimate purpose or purposes. For instance, if the intent is to construct a fast fighter airplane, the designers would want it to have thin, swept-back wings. If the airplane is to be a cargo type with the ability to land and take off at slow speeds while carrying a heavy cargo, the opposite would be true. The wings would need as much "lift" as possible; therefore, they would be far less sweptback and relatively thick. (You will learn about lift and aircraft design in the "Aircraft in Flight" text.)

The next step before the manufacturing process begins is the scale model, an exact replica in miniature of the future product—in our example, an airplane. Engineers can "test fly" the model in wind tunnels to determine the flow of air around wings, fuselage, and empennage. If any unfavorable characteristics are discovered at this point, changes in basic design can be made with very little cost to the manufacturer.

Once the scale model is determined to be satisfactory, a full scale



FIGURE 72

mock-up is constructed. This mock-up is built from components constructed by various craftsmen following blueprints drawn by draftsmen from plans conceived by aeronautical engineers.

The mock-up is not a working model. It cannot fly. It is built so that engineers can be sure components fit into the design as intended. Any needed changes that are found on the mock-up are reflected in revised engineering drawings.

The next step is the building of one or more prototypes—the first working models.

The prototypes are put together very carefully and mostly by hand-crafting. The manufacturer must first see if all the engineers' ideas and calculations really will work as intended before orders are given to "tool up" for production.

When the prototype(s) are completed, they must be tested. Static (or ground) trials, for example, test the smooth retractability of the airplane's landing gear, variable sweep of its wings, etc. Once the static, or ground tests, have been completed, test pilots take a prototype on many extensive flight tests to determine if the aircraft will hold together at and above design speeds and stresses. Also investigated during the flight test phase are the maneuverability, handling charac-



FIGURE 73

teristics, and all-round suitability of the aircraft for its purposes. In some cases, the same prototype is used for ground tests and for flight tests.

As stated earlier, the manufacturing processes involved with any complicated product are basically the same. In the above brief discussion of an airplane, an automobile could have been the example. The phases of need, model, mock-up, prototype, and testing apply equally.

When all "bugs" have been eliminated from the prototype or prototypes, it is time for production to begin. Mass production of products is a vital factor in lower prices for the customer and for filling demands for the product. United States industries have traditionally been

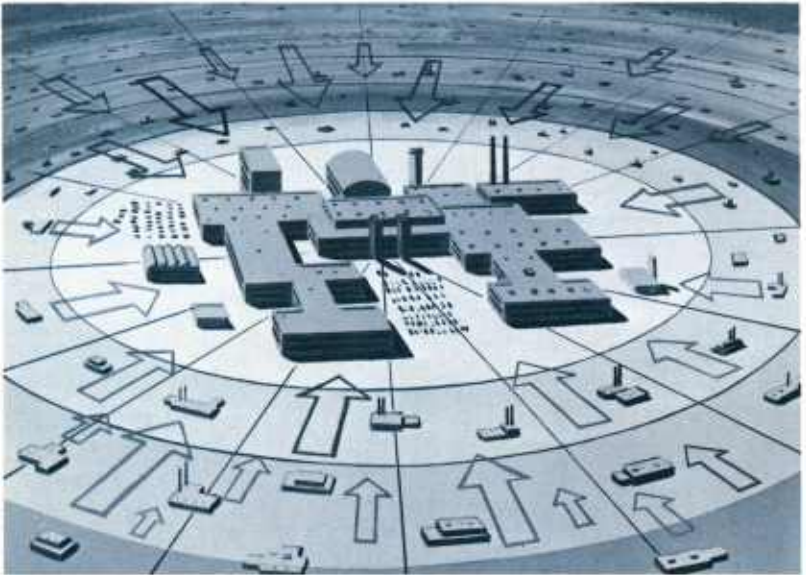

FIGURE 74 Subcontractors

noted for their know-how in mass production, and this know-how provides us with more products than are available to any other national group in the world. The ability to mass-produce tools of war for the defense of our nation has been our salvation from conquest by foreign powers. So we really owe our high standard of living and security to the resourcefulness and know-how of our nation's manufacturers. But how does this mass production scheme work? It's really too compli-

cated for us to examine extensively in this book; however, we can get the general idea.

The heart of mass production is the *assembly line*. This is where all parts of the product are put together in the order that they must be assembled. Assembly line layout in itself is a rather complicated matter. Management and production engineering personnel have a tremendous task to develop the best arrangement for all assembly phases.

True, it isn't too difficult to determine the sequencing of parts assembly, but many other factors are involved. The conveyor systems that carry parts to assembly lines must be chosen carefully, with consideration for the most economical design, weight-carrying capacity, speed with which the part must be transported, etc. Then to be determined are how many personnel will be required to load the conveyors and to perform the actual assembly work. All of these factors enter into product cost. Naturally the manufacturer wants to keep costs low so that his profit will be as great as the market (competitors' price and customers' ability and willingness to pay) will allow.

Prior to final assembly of the product, components must be constructed. Depending on the capability and diversification of the manufacturing complex, these components may be made within the same complex or they may come from distant plants owned and operated by separate companies. Still further back, the raw materials that make up the components are almost always supplied by industries that specialize in the processing of raw materials. Let's consider some examples:

In smelting mills, steel and other metals such as aluminum are processed from ores. When the metal is still in liquid form, it is poured into molds and allowed to harden into easy-to-handle "pigs." Pigs are transported to rolling mills where they were remelted and poured into shapes that can be formed into tubes, rods, and sheets. Automobile manufacturers, for example, purchase sheet steel to be shaped in giant pressure molds into various exterior body parts, such as the hood, trunk lid, doors, etc. These parts are all standard for a type and model of automobile, and they may be made at a location some distance from the automobile assembly plant. In any case, the fact that the standardized parts can be assembled quickly provides a great volume of production per day, and allows the manufacturer to sell his product at a competitive cost.

Manufacturers also subcontract certain parts and components, such as tires for an automobile or an aircraft, to specialized companies because it is usually more economical to buy than to make them. For instance, why should a manufacturer build radios for his automobile or aircraft when he can purchase them from a radio manufacturer at wholesale prices? When the radio is installed, its cost, plus a reasonable profit, is charged to the customer.

So it goes for the basics of manufacturing processes. All products start with raw materials. Raw materials are shaped or made into components, and the components are assembled into finished products—usually on an assembly line.

FIGURE 75

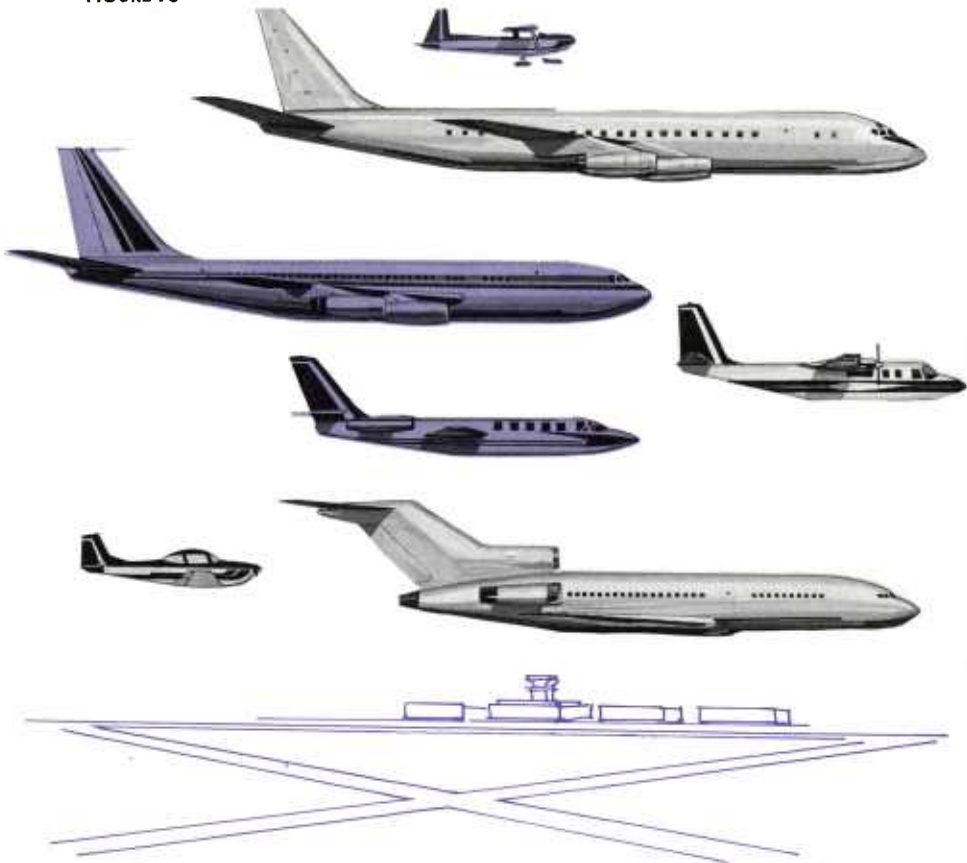

# CHAPTER 4



FIGURE 76 Piper "Tri-pacer"

HOW A SMALL AIRPLANE IS BUILT

In our various analogies discussing the basics of the manufacturing processes in the previous chapter you may have concluded that every-thing manufacturer in the United States is completed by mass production. This is true for most products, from toys to automobiles, but it is not quite true for light airplanes. Most airplane construction processes are accomplished by highly trained and skilled workers—practically artisans—who use hand-held tools to perform intricate tasks.

The nearest our nation ever came to true mass production of aircraft occurred during World War II. The Ford Motor Company used its mass-production know how to produce B-24 bomber aircraft at a rate of one per hour. This phenomenal production rate—spurred by the war—was not attained without some difficulty and tremendous expense, because aircraft are more complicated and must be constructed within much more exacting tolerances than automobiles.

Mass production techniques for light aircraft, however, are impractical because of the small demand in comparison to automobiles. If a way were found to use materials that are fully adaptable to aircraft and the mass production process, there would hardly be any need to build, say, 300 aircraft per day if the market could absorb only one. So manufacturers adhere to time-tested techniques of hand crafting or shop methods. This is why aircraft are so expensive to purchase. The demand is low and the production costs are high; to make a profit, the aircraft builder must charge a very high price.

Now let's examine in some detail just how the small aircraft on today's market are manufactured. We will start at the very beginning or "concept" stage and take you through each phase of the process, although much detail will be omitted because of our limited space in this text. Hopefully, you may soon be taking your first flight lessons in aircraft similar to the ones you will "see" being built.

## THE PRELIMINARY PROPOSAL

Every new type of airplane developed by our example company—Piper Aircraft Corporation at Vero Beach, Florida—begins with a preliminary proposal, and this is the usual procedure with other aircraft manufacturers. Although top management is the instigator of a preliminary proposal, the aeronautical engineers must come up with a preliminary design study for management to use in judging whether to proceed with the project.



FIGURE 77

Aeronautical engineer preparing a preliminary proposal

The preliminary proposal has a specific format (which will vary from company to company). The format insures a fairly thorough examination of what can be expected if the company decides to build the airplane.

A *summary* begins the proposal. This summary condenses into a few paragraphs many specifics about the airplane.

Next, the design engineer presents an *introduction*. Generally, this section contains an account of how the proposal for a new aircraft came about.

*Configuration specifications* is the section devoted to specifics. This section usually involves extensive data which give a more scientific basis for the reviewers of the proposal to use in their evaluation.

The *weight and balance* and *performance* sections show a brief summary, in tabulated form, of what has so far been presented in preceding sections of the proposal. In other words, the reviewer can tell at a glance how high and how far the aircraft will fly without refueling, its maximum speed, how many pounds of weight it will carry, and so forth.

The *economics section* tells the reviewer how much it will cost to produce the airplane. Of course this cost is estimated, and the esti-

mate, based on a combination of experience, known materials costs, and fairly accurate guessing, is broken down into various categories. Detailed estimates provide costs for the purchase of raw materials, such as coil aluminum and tubular steel. Also included are estimated manhours required to develop and test prototypes and to produce each airplane delivered to the customer. Other items are shown such as the amount needed for standard equipment (tires, engines, radios, etc.) purchased from other manufacturers.

Concluding the economics section is a summary of development and production costs. This allows the reviewers to see how much money the company will have to spend just to get the airplane ready for assembly line production, and how much money will have to be spent to prepare one airplane for delivery. By considering all of these costs plus the amount normally spent for advertising, the company can determine how much will have to be charged for the completed airplane.

The next section of the proposal is entitled *discussion*. Here the engineer or engineers have the opportunity to recount briefly many facts that have been presented in previous sections and to compare the alternate approaches to building the airplane.

The *conclusions and recommendations* section terminates the formal proposal. Here the engineer(s) summarize vital characteristics of alternate designs and methods of construction. The data in this section give the reviewer enough information to decide whether the company should build the airplane, and, if so, which of the alternatives would be most advantageous.

After the preliminary proposal is agreed to, what happens next? In effect, the design engineers have to make a very detailed report on every aspect of the proposed design. This report, which receives careful scrutiny by management, contains many, many computations and conclusions concerning every aspect of the airplane's design and performance characteristics.

## DEVELOPMENT ENGINEERING

After management approval, the design engineers' report is given to the Development Engineering Department which will perform its mission in accordance with the report's data.

Note in Figure 78 that this department is subdivided into branches and sections for specialization. Also note that the *design* and *experimental* shops are the only two branches which have sections. You will

FIGURE 78

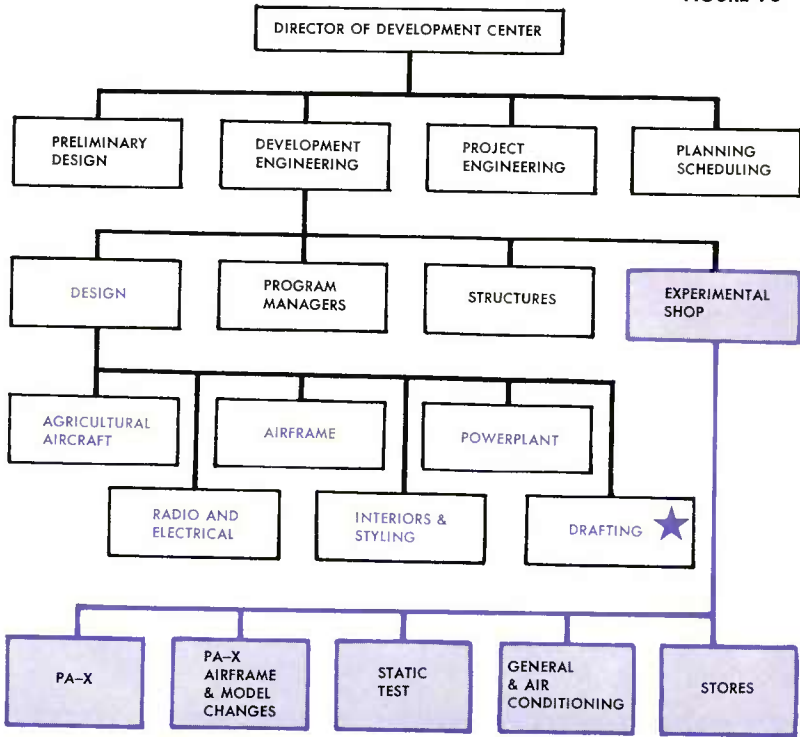

understand why as we progress in our discussion of how an airplane is built, but remember that the organizational structures found in one manufacturing plant will never coincide exactly with those in another. This is because management must organize its operations according to the jobs to be done. Back to Development Engineering:

One of the most important sections—*drafting*—transforms engineering data and the engineers' sketches into drawings that become blueprints. A blueprint must be made for *every* part, and each print must contain *exact* instructions and measurements.

If possible, standard parts will be used. Even so, updated blueprints will show that they apply to the new aircraft. For new parts and assemblies, preliminary prints are drawn so that the *experimental* shop can fabricate a prototype part. In fact the "print" may not be a blueprint at all. It may be only a plan (two-dimensional) along with a three-dimensional sketch of the part or device. In such instances, the engineers do not know whether it is feasible to build the item, so the

experimental shop tries a quick model. If the item can be built, the experimental personnel will offer instructions or suggestions for the item's final specifications.

If the airplane is to be a new, small two or four place model, about 3,500 drawings are necessary. These first drawings are just for the prototypes that will be built. Many—perhaps most—of the drawings will be extensively revised as construction, static testing, and flight testing progress.

Highly skilled specialists in the experimental shop perform the challenging tasks that produce the prototype or prototypes. Most of these specialists are “experimental aircraft mechanics,” and a few are engineers. (The title “experimental aircraft mechanic” is not standard throughout the industry.)

Using the numerous drawings, the experimental shop builds each prototype part by hand. You can understand why experimental aircraft mechanics must be exceptionally versatile. On the one extreme, a mechanic may have to model in wood the part he is working on; afterward he may have to use plastics (in this instance fiberglas cloth and resins). At other times the same mechanic may be riveting sheets of aluminum to an airframe, welding tubular steel, or arranging the wiring for an electrical system. These versatile personnel are among the highest—if not the highest—paid in the non-professional field.



FIGURE 79 Typical design and drafting section



FIGURE 80 Fatigue and wing loading static tests

Piece by piece the prototype airplane grows. As each major component is completed, it is tested, over and over. Note in Figure 80 that a stabilator (combination stabilizer and elevator) is on a special test stand to determine its "lifetime"—the point in time where one or more of its structural parts will fail. Through this test procedure (setting up vibrations of varying intensities), the engineers and mechanics can determine just how many years a unit will last before it becomes unsafe. Don't get the impression that an airplane is programmed to remain airworthy for only a certain period of time, such as ten years; actually, it is built to remain structurally sound for more years than the lifetime of its owner, providing the aircraft isn't subjected to maneuvers that exceed its design capabilities.

Also note in Figure 80 that a partially completed prototype is suspended in a special device. Here, its wings will be tested for the amount of load they can withstand. This load test is on a per-square-inch basis. The load (pressure) on each square inch of the wings will vary from moment to moment according to how much weight the airplane is carrying and the type of airborne maneuvers being simulated. Therefore, the tests must show exactly how much weight per square inch the wings can tolerate before breaking. Results of such testing en-



FIGURE 81 Experimental aircraft mechanic with prototype air conditioning unit

able the manufacturer to establish certain limitations within which the pilot must stay as he flies the aircraft.

At this point we should emphasize that the engineers and experimental aircraft mechanics in this department are not limited in their work assignments to new types of aircraft only. In reality this department is kept busy at all times working on new or unproved features for the company's line of aircraft. If there are no completely new aircraft to be developed, model changes occur each year, and the work involved with one model change is quite extensive. Note in Figure 4-4 that an air conditioning unit is in the embryo stage. This unit will be adapted to, and available for every aircraft that the company manufactures.

Tests, tests, and more tests occur not only as a prototype airplane evolves but also after it is completed. Three or more prototypes may be built before production begins. One of the finished prototypes remains earthbound for various static tests (wing loading, etc.). The other two (or more) are available for flight tests, and one of these is on standby status just in case the other is lost.

All the data obtained from the various construction and testing procedures are considered, and, where needed changes are indicated on

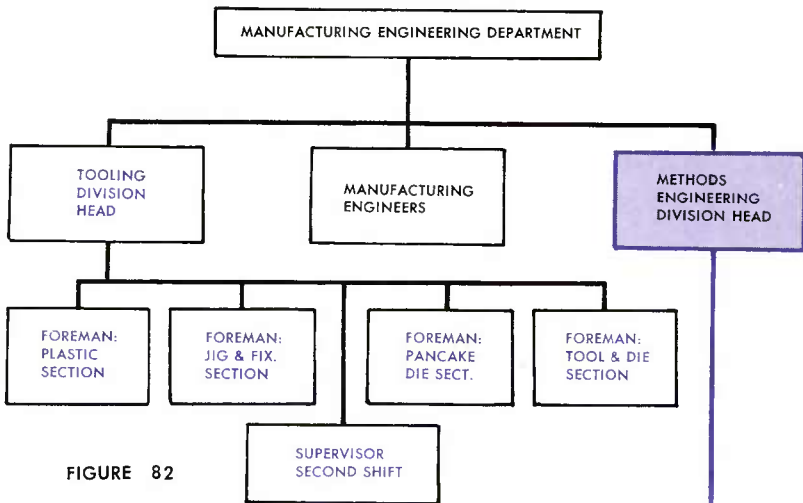

FIGURE 82

the engineering drawings or blueprints. Finally, after the thousands of drawings have been appropriately modified, it is time for the next step—preparing for production! Actual production is still a long way off. Preparation begins when the large packet of blueprints leaves the development center for the *Methods Division*. (Again, this may not be the title of the same type of division in another aircraft manufacturing plant.)

## MANUFACTURING ENGINEERING

In Figure 82 you will note that the Methods Division and Tooling Division are parts of the Manufacturing Engineering Department. It is in Methods that the most detailed planning imaginable takes place.

Without going into too much detail, we can say that Methods Division engineers examine every blueprint and decide how the aircraft is

going to be build—down to the last rivet. If the Piper plant itself has, or can produce, the needed tools, the *Tooling Division* goes into action. If *Methods* analysts conclude it would be cheaper to purchase tools, the *Methods* tool order section places commercial orders. Materials such as aluminum, plastic, and steel, must also be ordered from commercial sources. To complicate the picture, specifications vary for the same materials according to use; for instance, aluminum may vary in thickness depending on whether it is applied to the wing or to the fuselage. Only the amount of material necessary to complete the number of aircraft programmed for sale will be ordered to prevent tying up the company's money and space in what is known as materials inventory.

When *Methods* personnel order commercial source tools and materials, they specify delivery dates so that the tools and materials will be at the plant and ready for use when production begins. Take notice of our statement "when production begins." This means that the company wants the materials to arrive just before they are used—not several months before. Therefore, raw materials and major items of equipment such as engines, tires, radios, navigation instruments, and so forth, should be in the plant and ready for use just before they are needed.

There are still several things left to do to prepare for production. The assembly layout for the aircraft has to be decided. Blueprints have to be duplicated according to the number needed by the various fabrication and assembly stations, and a blueprint accounting system must be set up. If you recall our mention of modifications or model changes, you will understand why it is imperative that only current blueprints be available to insure that only new parts—not outmoded ones—are manufactured. Therefore, the accounting system for blueprints must be infallible.

Coordination and planning for production must also include quality control personnel. Later, we will discuss the quality control function.

Work orders are made for each action that goes into building an airplane. Since the work "travels" from one station to the other until the part is made or the assembly is completed, these work orders are known as "travelers." Each of the 3,500 blueprints may require several travelers, so we can multiply 3,500 several times to obtain the required number of travelers. Again accuracy is the watchword. The clerical personnel who make them up must work rapidly and without error. Just one digit or decimal out of place can cause numerous pro-

duction problems. An error, say, in the numerical designation for the thickness of aluminum sheeting to be applied to a fuselage would cause many thousands of dollars in lost time and material. Of course the possibilities for error are tremendous in practically every phase of airplane manufacture, but care and frequent inspections keep error rates very low.

## TOOLING

Very well, we know that travelers are prepared for everything that is manufactured or assembled. The same applies for tools that must be made by the Tooling Division. The tool ordering section of the Methods Division not only makes purchase orders for commercially produced tools, but also sends travelers to the Tooling Division for tools that must be made "in house." Now let's see how the Tooling Division contributes to the construction of an airplane.

The Tooling Division is subdivided into "specialty" sections: plastics, jig and fixtures, pancake die, and tool and die. The plastics section makes molds used to form fiberglas parts, such as wing tips and doors. The jig and fixtures section builds the steel frames which hold parts of the airplane in perfect alinement while the parts are riveted together. The pancake die section makes steel dies which are used in stamp presses to cut pieces out of aluminum sheeting—in much the same way cookie dough is cut; also this section makes templates (patterns) to be used by routing and cutting machines. Finally, the tool and die section makes the contoured, three-dimensional dies which are used to form parts in huge "hydroforming" presses. In addition to dies, the section makes special cutting tools that machinists use on their metal turning lathes.

When tooling personnel make a mold to be used in forming plastic (fiberglas) parts, the mold starts with a process called "lofting." Lofting begins in the machine shop where aluminum sheets are milled (cut) into templates. The outer edges of the templates, when they are fastened together with appropriate spacing between, form the outer contour of the part. The spaces between the templates are filled in with a special material which hardens into a stone-like surface. This surface is ground and polished until a perfect contour of the part is obtained. Next, this positive part contour is used to make a negative contour mold. Several methods may be used to make a negative mold, but it is in the negative mold where resins and fiberglas sheets are com-

bined to form the thin, lightweight, strong aircraft part. If the mold thus made passes inspection, it is delivered to the fabrication personnel for "mass production" of the part.

Specialists in the jig and fixture section also have to take the greatest care to maintain accuracy—within thousandths of an inch—in the tools they make. Today, sophisticated instruments are used to insure this accuracy. We should take time to discuss briefly at least one of these instruments.

The optical tooling instrument, shown in Figure 83, is essential to speeding up the construction of a large tool such as a jig. This instrument combines a number of telescopic optical devices which outwardly look very much like a surveyor's level. By placing these devices properly, it is fairly easy to establish vertical and horizontal planes that are virtually perfect. Thus, as a jig is constructed within this field of planes, technicians can be certain that every part of the jig is in alignment with the other, that exact spacing of fixtures on the jig can be obtained, and that angulation of fixtures, or the jig frame itself, is as planned.

Even after every precaution has been taken, a tool (or jig) may not have the necessary accuracy. Therefore, the tool is used to construct a

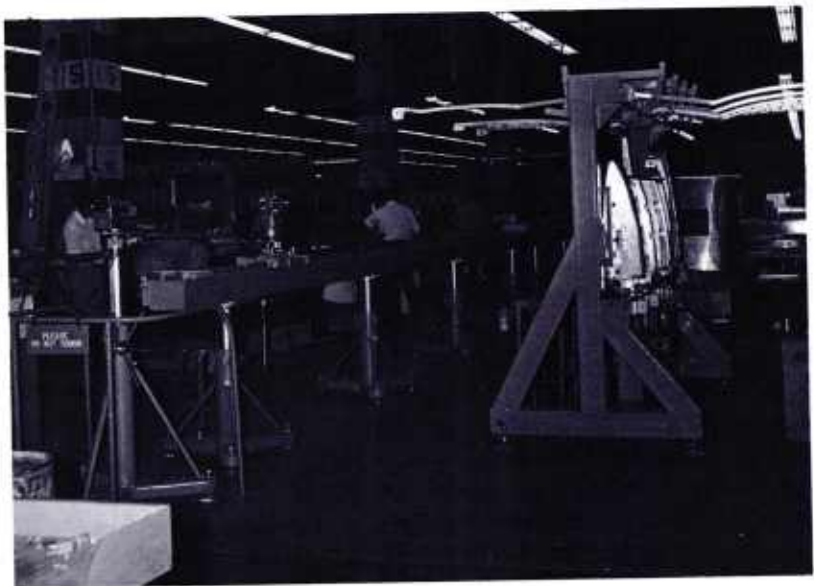

FIGURE 83 Optical tooling instrument (left), special jig (right)

sample of the aircraft part. Each step of the construction procedure is checked carefully to insure that the tool will do its job. If something is found not to work properly, it is corrected. After the sample part is completed, it is given an overall examination for production acceptability. Once this last barrier is passed, the tool is delivered to the appropriate production station or it is stored until needed.

A contour milling machine is another labor-saving device that probably is used by every aircraft manufacturing industry. This machine (see Figure 84) has an optical scanner which follows the outline of a two-dimensional "print." The movement of the scanner is geared to the part of the machine which cuts (mills) out of aluminum sheets the pattern followed by the scanner. One of the more unique features of this machine is its ability to vary the scale of its work. For example, several undersized, two-dimensional drawings may be crowded onto a single mylar sheet, but the machine can be set to enlarge and reproduce these two-dimensional patterns in metal in the exact size needed.

The pancake die section makes the steel dies that operate, as we said earlier, much like a cookie cutter. That is, this die makes "holes" in a sheet of aluminum. The holes may be round or they may take various shapes according to the need. Pancake dies, used on the ribs of a

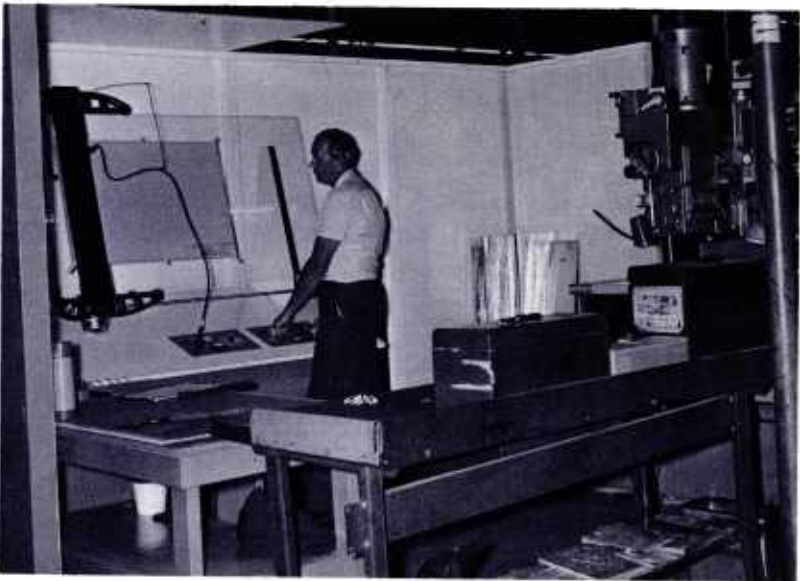

FIGURE 84 Contour milling machine

wing, remove unneeded weight, yet allow the wing to retain structural strength.

Personnel in the tool and die section use their metal turning lathes and other steel cutting machines to make contour dies that are used in large presses. They also make tools that will be used by production personnel to turn, mill, rout, and punch the various parts that make up the aircraft. Again, each completed tool must pass a meticulous inspection before it is certified for production work.

Look at Figure 85. This is a general view of a tool storage area. When any tool is not actually needed by production personnel, it is returned to this storage area. Before it is stored, a sample of its last work is inspected for conformity to production specifications. If the sample is not up to standards, the tool is destroyed or repaired—according to its condition. If the sample is satisfactory, it goes to storage along with the tool.

By now you should have come to the conclusion that everything in an aircraft manufacturing plant is always accounted for and that its condition is known. Just this far in our discussion we have seen that blueprints, supplies, purchase orders, work orders, and tools have watchful eyes kept on them at all times. As our discussion progresses, this fact will become even more evident.



FIGURE 85 Tool room and storage area



FIGURE 86 Electrical Harnesses

## ELECTRONICS

In the Piper plant, electronics workers are mainly involved with the preparation of electrical harnesses. The harnesses are simply wires of varying sizes and colors which are banded together so that they can be installed in the aircraft fairly easily without taking up much space. Workers use large layout boards (see Figure 86). Outlined on them is the contour that the harness must take, and pegs are placed at specific points along the outline to make the wires stay within the specified contour line.

As each wire is placed in the harness guide and cut, it is tested to see that an electrical current will flow through it. After the harness is completed, it is tested again as a unit before being delivered to the assembly line.

In addition to electrical harnesses, the electronics unit may build other devices such as radio boxes, radio power assemblies, etc.

Some manufacturers, as mentioned in the beginning of this chapter, make many of the electronic instruments that are used in their aircraft. Others purchase such instruments from commercial sources. The latter is the case for aircraft built at Piper's Vero Beach plant, with the exception of one device which is known as a marker beacon.

## INSTRUMENTS

The instruments section, like the electronics section, is somewhat autonomous in its operation. To the "instrument room" come all instruments that are placed in the airplane for the pilot's use. This includes both electronic and non-electronic types.

Each instrument is tested thoroughly, and it is calibrated to make certain that what the instrument tells the pilot will be accurate. These testing procedures require instruments section personnel to use some rather elaborate equipment. Vacuum pumps and pressure pumps simulate precise atmospheric and wind conditions that certain instruments will encounter as an airplane flies through the air. Special electronic testing equipment tests the circuitry of radio navigation instruments. Other electronic testing equipment simulates signals that instruments will receive from "sending" units located on the ground.

Because of the importance of guaranteed function and extreme accuracy, the Piper Company provides space for full-time representatives from the manufacturers of instruments used in Piper aircraft. Working together with Piper specialists, the manufacturers' representatives can take immediate action to correct any instrument defect, and the manufacturer can be notified quickly so that the corrective actions can become part of the production process.

As you will see later, when we discuss final assembly, the instruments section is located just off the end of the final assembly or final airplane line. This is because instruments are among the last items to be added to an airplane before it is test-flown.

## RECEIVING

This section is where all purchased supplies and equipment are delivered. As soon as a shipment arrives, it is inspected for condition and specifications.

Large coils of aluminum are scrutinized closely for possible perforation and bent edges. Crates containing propellers and engines are opened to see if their contents have been damaged during shipment or if there are any exterior parts that are malformed or missing entirely. Some of the supplies received, such as plastic sheets for windshields and upholstery material, have been pre-cut by the manufacturer according to the company's pattern specifications. On hand in Receiving are metal templates used to see that the company's pattern specifications have been followed exactly. When a shipment is damaged or

doesn't meet specifications, the defective material must be returned for replacement or correction.

Once these supplies pass inspection, they are either stored or delivered to the plant section which needs them immediately. As you can imagine, it takes much paper work to operate this section because all supplies and equipment must be accounted for continuously.

## FABRICATION AND ASSEMBLY

Thus far we have been talking about "peripheral" operations that initiate and support the fabrication and final assembly operations. A brief summary is appropriate at this point:

- a. The airplane begins with a preliminary proposal to management.
- b. The Development Center provides all engineering drawings (blueprints) required to build the airplane, and builds and tests prototype static test and flight test models.
- c. The Methods Engineering Division works out the details of construction, orders supplies and equipment, and prepares the thousands of required work orders (travelers).
- d. The Tooling Division makes all non-standard tools, and accounts for both standard and non-standard tools.
- e. The Electronics Section prepares electrical harnesses and other items that will become part of the airplane's electrical system.
- f. The Instruments Section receives and tests all electronic and non-electronic instruments that will be used in the airplane.
- g. The Receiving Section receives, inspects, stores and issues all supplies and equipment.

Fabrication and final assembly take up the most floor space in the Piper plant, or any aircraft manufacturing plant for that matter. As smaller parts are made and put together to make larger parts, the requirement for space grows until a very large area is needed for the long lines of completed, ready-to-fly aircraft.

**FABRICATION.** Throughout the Fabrication Department, aircrafters are busy cutting, stamping, bending, routing, drilling, punching, welding, and molding the thousands of pieces that will be assembled into the airplane's minor and major component parts. This department, we should emphasize, does not perform assembly work—its function is to make all the pieces necessary for various parts. However, it does rivet or bolt together some of the pieces or sub-assemblies.

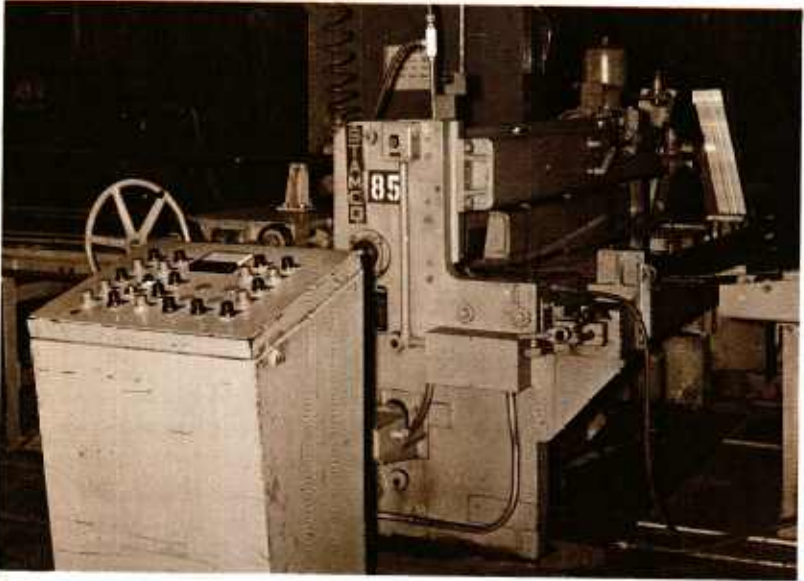

FIGURE 87 Shearing machine

*Shearing.* Aluminum is the staple material used to build an airplane, and the average small airplane contains more than 95%, excluding engine and tires. One of the first jobs of the Fabrication Department is to cut "sheets" of various lengths from large coils of aluminum. The shearing machine which converts the coiled aluminum into sheet aluminum is shown in Figure 87. Note that the coil aluminum enters the picture from the right, and goes between pressure-exerting rollers before it is cut into specified lengths. Pressure removes the tendency for the aluminum to curl after it is cut.

The shearing operation is not a haphazard endeavor. The exact sizes and the number of aluminum sheets needed to make the aircraft were determined long ago in the Methods Division. The aluminum is cut so that the greatest number of parts can be obtained from it with the least amount of wastage.

In addition to the large shearing machine for coil aluminum, there are other machines whose jobs are to cut tubular steel and other forms of aluminum into specified lengths.

*Router/Cutter Operations.* Recall that we said the Tooling Division makes many different templates, or patterns, used to cut the various part shapes out of the sheet aluminum. Cutting and routing machines



FIGURE 88 Form break operator

can cut and rout parts from several aluminum sheets simultaneously (called stack routing). After they are cut, the flat pieces usually are deburred. Deburring means that the rough edges left from the routing and cutting operation are removed. Most of the cut pieces next go to the "Press Shop" to be shaped.

*Press Shop Operations.* Many types of pressure machines are used to give the flat aluminum pieces their final contoured shapes. The machines operate by mechanical or hydraulic principles, depending upon the type of pressure required.

Mechanical presses are used for rapid operations, and their force is provided by a flywheel and ram. As shown by Figure 88, the mechanical press or, as it is called in the trade, a PRESS BREAK is used mainly to bend an aluminum part to a certain angle. This is normally known as a "form break," and the term "break" does not mean that the metal is broken in the usual sense. Rather, it means that the shape or form of the metal is changed quickly. The metal pattern is placed in the die. One half of the die is stationary, and the other half is attached to the ram of the form break machine. As energy is built up by the spinning flywheel the ram is raised to a certain height and released quickly to fall on the metal to form, or bend, it to the desired shape.

The form break works so rapidly that a worker can complete an operation almost as fast as he can feed the metal to the machine.

Hydraulic presses exert gradual pressure, and are used to form more or less sculptured shapes. The mechanical press is not suited to this type of work because it would form the metal so fast that, even if the part didn't break, it would be weakened in certain areas.

By studying Figures 88 through 91 you can see several types of hydraulic presses at work. Two of these presses deserve special mention:

The *bag press* (Figure 90) is unique in that many, many small parts can be formed simultaneously. Note that the workers are placing precut aluminum blanks on their appropriate dies. When this is completed, the tray of dies goes into the large cylinder, shown at the top of the illustration, where sheets of rubber are forced to "flow" slowly around the respective dies, and where the needed pressure is exerted to bend the aluminum blanks. This pressure can amount to as much as 8,000 tons per square inch. Not shown in the illustration is another tray-loading area, on the other side of the large cylinder. This enables twice as much work to be accomplished. While one tray is in the cylinder, workers on the opposite side can be loading a second tray.



FIGURE 89 Hydraulic press



FIGURE 90 Bag press



FIGURE 91 Stretch press

Figure 91 shows workers using a *stretch press* to form the upper parts of aircraft cockpits. Metal parts to be formed in the stretch press must be especially tempered (annealed) (heated/cooled) so that they will be ductile enough to be stretched without breaking. The sheet aluminum patterns used in this operation are first tempered, then frozen, and subsequently removed from the deep freeze and allowed to thaw slowly. They must be formed in less than 24 hours, however, or they will return to the “hard” state even at a temperature of 72°F.

With everything ready, hydraulic pressure is exerted to make the form on the stretch press rise very slowly. The amount of upward travel has, of course, been predetermined to insure that the aluminum will be stretched just enough to form the part as intended. The foreground of Figure 91 shows that this process is not always successful; sometimes the metal tears or it breaks at the points where it is clamped. All is not lost, however. Ruined parts are sold back to the original supplier as scrap metal.

*Vacuum Forming.* A number of the parts used for the interior trim of a modern airplane have no bearing whatsoever on structural strength or increased performance. The trim is strictly for beautification or “eye appeal.” Therefore, the manufacturer can use new lightweight synthetic materials to make the most of the trim. The material,



FIGURE 92 Heat and vacuum machine



FIGURE 93 Cutting fiber-glass cloth

delivered in colored sheets, looks very much like illustration board. Yet it can be molded into practically any shape.

Whereas the forming of metal parts in presses requires much pressure, the exact opposite is true for this synthetic material. What is required here is a combination of heat and vacuum. Figure 92 shows the vacuum press. Dies of various contours are first placed on the bed of this press. Then the synthetic sheet is placed so that it will rest on the tops of the dies. An electric heating element beams its rays down on the sheet of synthetic material until the material becomes very pliable. Then, the upper half of the press closes and seals with the bottom half. When the seal is perfect, a vacuum pump produces just enough vacuum to cause the synthetic material to mold itself around the dies.

Notice the large fans in Figure 92. When the two halves of the press separate, the fans come on automatically to cool the synthetic sheet which has now conformed to the dies. When the material is cool enough, a worker removes it and cuts out the formed parts.

*Fabric Cutting and Plastics.* Aircraft manufacturers have found many ways of using plastics. This is a general term applied to fiber-glas/resin mixtures and plastic sheets. In Figure 93 you see a worker carefully cutting layer after layer of fiber-glas into planned par-



FIGURE 94 Plastics department



FIGURE 95 Windsield plastic

terns. The fibreglas may be a true cloth—of varying weights—or it may be a loosely pressed matt. The reason for care in the cutting operation is that the patterns are delivered to the plastics department where they will have to fit neatly into the molds for which they were cut.

Figure 94 shows an overall view of part of the plastics operation. Note the many molds that are visible. Specialists first put a smooth, thin, coat of “separator” in the mold to insure that the plastic part will not stick. Then, on the “separator,” a uniform layer of resin is applied, quickly followed by the precut fibreglas cloth, or matt, and then more resins. After a certain period of curing, the resin polymerizes or passes from a sodden mass into a solid, and the formed part is removed from the mold, trimmed and “polished” and delivered to the assembly area of the plant.

Another portion of the plastics operation works with true plastics—the material that is formed into windshields and windows. Here the operation is fairly simple to perform. Whether the clear plastic sheets are precut by the supplier or cut in the plant, the plastics department receives the plastic in the pattern it must have. The flat patterns are placed in an oven where they are heated until they become very plia-



FIGURE 96 Sheet metal mechanic

ble. Then all the operator has to do is remove the pattern and place it into the appropriate mold, as shown in Figure 95. After cooling, the plastic, which will retain its shape indefinitely, is ready for installation.

*Sheet Metal Operations.* Machines can do only so much. After some machines have cut the sheet aluminum, and others have bored or stamped holes in it, or have bent it, a human being must complete the job. This is exemplified in Figure 96 where a sheet metal worker is checking the contour of a trailing edge rib after he has fluted its edges. (Fluting is the term given to the corrugated edges that show in the stack of trailing edge ribs on the worker's far right.)

Other operations in the sheet metal area include "rolling." In this process, a gradual and uniform bend is applied to large sheets of aluminum. Usually this type of operation is used for the aluminum "skin" that will be attached to the leading edge of a wing.

*Machining Operations.* The accuracy required for many parts of an aircraft can be obtained only by specialists using hand-operated metal-working lathes and mills, but many other jobs can be done automatically.

The automatic lathe shown in Figure 97 has been programmed (using a punched tape) to do every operation necessary to make a part that is used in the landing gear assembly. The lathe automatically feeds a large steel rod from the side (not shown). A certain amount of the rod is advanced first. Then the machine bores and turns and cuts the rod as programmed. Of course, an operator must stand by to monitor the machine in the event it malfunctions in some way.

An automatic milling machine is shown in Figure 98. If you look closely, you can see a landing gear casting set up for milling. The machine has a rotating head which carries several different types of milling and boring tools. After the operator inserts the casting into a holding device, he "pushes a button," and the machine accomplishes every action needed to prepare the casting for additional landing gear parts that will be fitted to it.

*Tube Bending and Welding Operations.* Many types of tubing are used in a small airplane. Whether the tube is small and is made of copper or steel for oil and fuel lines, or whether it is large tubular steel intended for motor mounts, it has to be cut, bent, and, in some cases, flanged (spread). The small copper and/or steel tubing is first cut to predetermined lengths; then, the necessary fittings are attached to the ends, and the ends are flanged so that the fittings will not come off and will make snug, leak-proof joints.

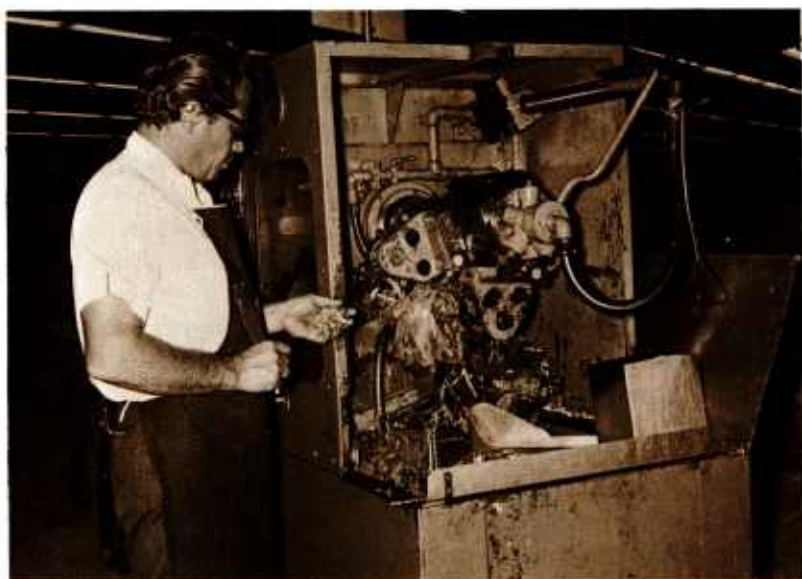

FIGURE 97 Automatic lathe operator

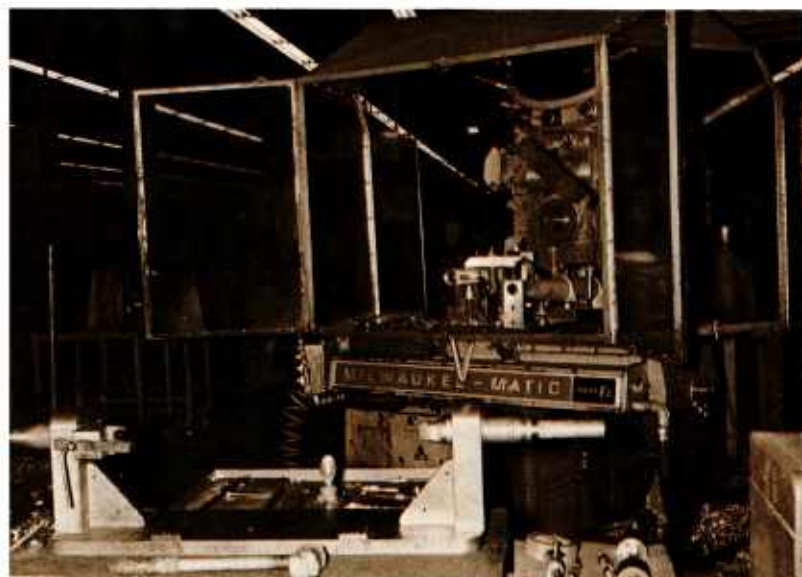

FIGURE 98 Automatic milling machine



FIGURE 99 Welder completing engine mount

The larger tubular steel, in smaller airplanes, is used mainly for engine mounts. As depicted in Figure 99, welders fit together the various pieces of the motor mounts, and weld them with such expertise that there is no chance of their coming apart. In fact, the welded joints of engine mounts are much stronger than the steel they are made of.

*Seats and Upholstery.* Another important item that must have structural strength approaching that of motor mounts is the seat assembly. The modern, adjustable seat also uses tubular steel as its basic framework. (See Figure 100.) The "front" seats are constructed so that the pilot and copilot—or right seat passenger—can adjust their seats by moving them forward backward, upward, and downward.

Applying upholstery to the various types of seats is one more task performed by the Fabrication Division. In this particular plant, the upholstery is attached only. The company decided that it could purchase pre-sewn seat covers and padding much more economically than it could produce them.

After the seats are upholstered, they are delivered to the assembly area work stations that will place them in the airplane.

*Small Parts Assembly.* Although it is true that "fabrication personnel" are mostly restricted to making all the pieces that "assembly per-



FIGURE 100 Upholsterer completing adjustable seat

sonnel" will put together, there are times when some assembly work must be performed by the fabrication personnel. There is no need for us to go into details, but engine mounts and seats discussed above are examples of this situation. The same applies to other parts which need special bracing that has to be riveted to a part before it is considered a part, etc.

*Small Parts Paint.* As we will see later, an airplane requires a large amount of paint, and most of it is applied after the airplane is completed; however, for preservation or customer appeal, many small parts may be painted before final assembly. Figure 101 shows only one segment of a rather large small parts paint shop.

Several procedures are used to apply paint or special preservatives to small parts before they are delivered to the plant's assembly area. If a part needs to be painted for customer appeal, it probably will receive only a light coat with a spray gun. On the other hand, if the item is going to be exposed to the weather and to rather extensive use, it may need several coats of paint applied by vat dipping.

Aircraft that are sold to some foreign nations are required by the purchasing nation's law to have certain parts coated with a special preservative—a green zinc chromate. Small parts paint is involved

with this process, too. The preservative isn't a paint, as we think of paint, but the application of it insures that the part will be impervious to the corrosive action of moisture—or of chemical-laden air. Of course, the process means that an additional cost must be added to those aircraft with parts thus treated.

Summarizing briefly, we have seen that there are many operations involved with the making and preparation of parts that are needed to build an airplane. We have not discussed all the detail work that has to be done in this fabrication process, but you know that much mechanization is necessary to obtain required precision in the least amount of time. You know also that the human being is still the greatest asset that a manufacturer has. It is the aircraft worker, after all, who tells the machine what to do and monitors what it does. Even after the machine completes a part, the human being must deburr, polish, clean, inspect and paint it.

You should remember that every bit of the work done in fabrication procedures is authorized by a work order, or traveler. Also, the traveler tells the worker how the part must be made, how many must be made, and when to deliver them after they have been completed. After all the instructions on a traveler have been followed, the traveler's job is completed, and it is returned to Methods for filing.



FIGURE 101 Small parts paint shop

**ASSEMBLY (*Sub and Final*)**. Thus far we have been discussing the fabrication of small parts or pieces which become assemblies, and we pointed out that all these items are delivered to the assembly portion of the plant where they are fitted together to become an airplane. What we need to emphasize here is that assembly involves two distinct processes: sub assembly and final assembly.

As we proceed with our discussion of assembly operations, you are encouraged to refer frequently to Figures 102, and 103, Figure 102 provides an exploded view of one of the Piper Company's airplanes, showing the sub assemblies separately. Figure 103 provides a floor plan and work flow in the assembly area of the plant. By comparing the two figures you should get a better understanding of how the assembly system works.

Although our floor plan illustration gives the impression that the assembly area is completely "walled off" from the fabrication area, this is not the case. Both operations are under one roof, so to speak, with wide corridors connecting them. Through these corridors the fabricated parts are delivered to the various sub assembly areas.

Note in Figure 103 that the assembly stations or areas are numbered. Starting with numbers 2725 and 2726, all the parts needed to build the vertical fins, stabilators, rudders, flaps, and ailerons are placed in jigs and riveted together. As the completed assemblies are needed, they are delivered to the fuselage line in the 2787 area.

Moving to the right, and to area 2775, we find the place where the landing gear are assembled. For Piper Aircraft's Cherokee models, there are nose gear and main gear assemblies. The two main gear are attached to wing assemblies, but the nose gear is attached to the engine mount. This is why our flow pattern shows the types of gear taking separate routes. The main gear are trucked across the fuselage and final airplane assembly lines, and are delivered to the 2774 area where they will be attached to the completed wings. How the main gear are attached depends on whether they are "fixed" or can be retracted into the wing during flight.

The nose gear are transported from 2775 to 2776 where they are mated to the engine mounts. Engines are not manufactured in this plant. They are purchased, as we stated earlier, from commercial sources. But the engines do not have all the parts they need when they arrive at the plant. The necessary parts are attached just before an engine is affixed to the aircraft. Note in Figure 104 that a worker is completing the attachment of an exhaust/manifold system to an en-

FIGURE 102 Exploded view of Piper aircraft

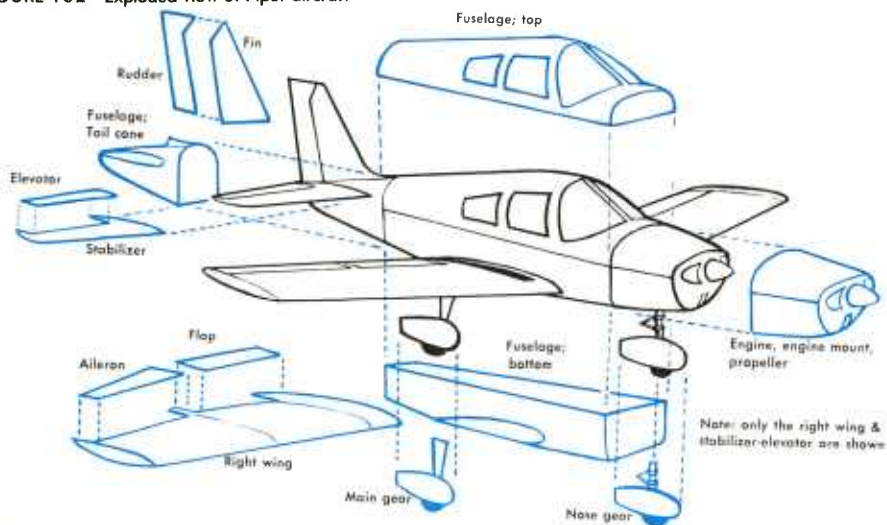
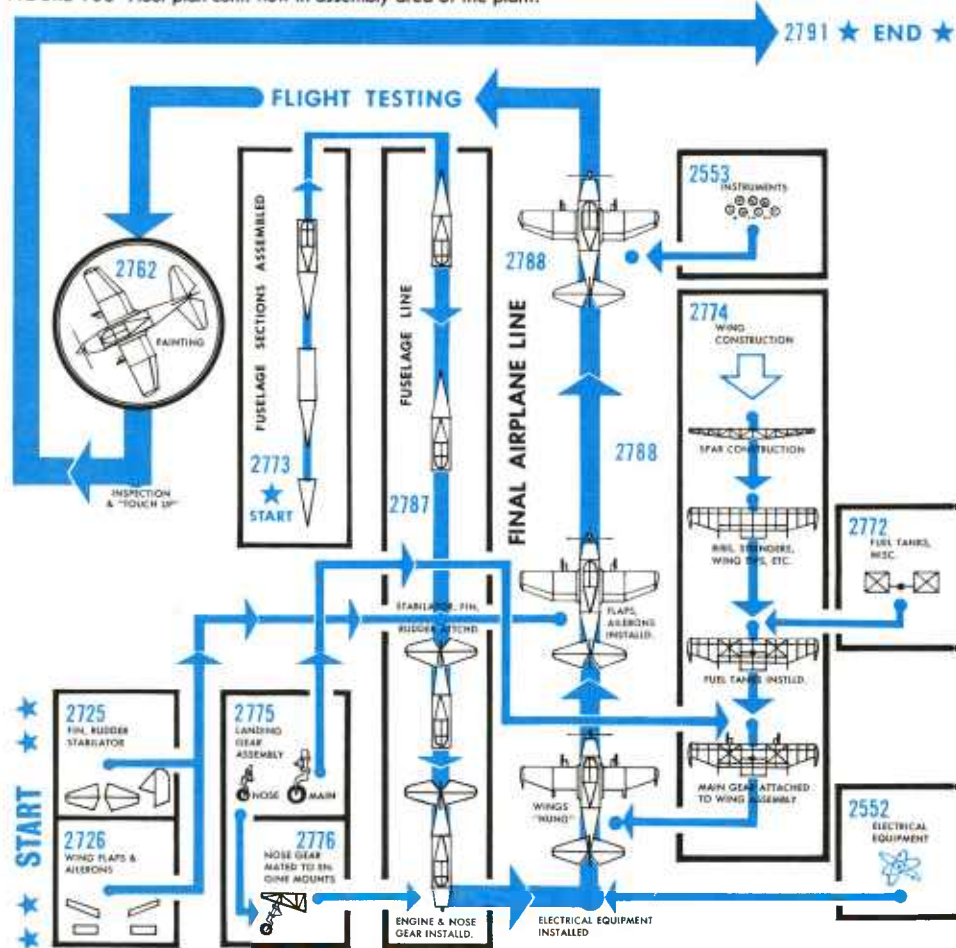

FIGURE 103 Floor plan cont. flow in assembly area of the plant.



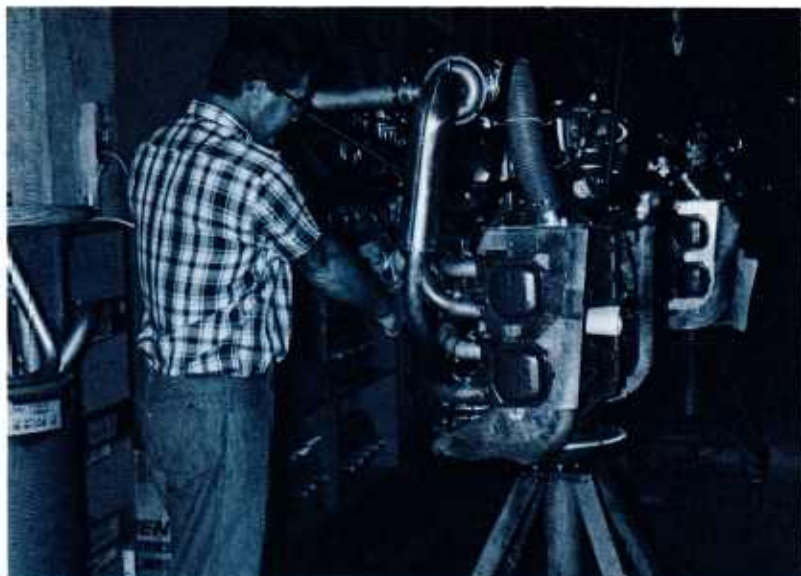

FIGURE 104 Installing exhaust manifolds

gine. Also note a second engine on the "line" and the barrels containing more exhaust/manifold systems. The last step in this engine build-up process is the attaching of the nose gear. Afterward the complete engine/nose gear unit goes direct to the final fuselage line where it will be mated to the appropriate fuselage.

Now look at Area 2773. Here, the three sections of the fuselage are made. These sections are the upper cockpit, the lower cockpit and the tail cone. Building the fuselage in sections makes it easier to install certain parts. Into the upper cockpit assembly go such items as the firewall and instrument panel, while in the lower cockpit assembly the spar box and "tunnels" (which cover electrical harnesses and control cables) are installed, along with the necessary flooring. The upper and lower cockpit assemblies, after each is completed, are transferred to a mating jig where the two units are joined.

Since the tail cone portion of the fuselage does not involve many complex assembly operations, it is built as a complete section. Each completed tail cone goes direct to the fuselage mating jig.

Mating jigs are used to hold the tail cones and the already mated upper and lower cockpits in perfect alignment while they are fastened together. (See Figure 105.) After this operation is completed, there is

some semblance of an airplane, although the assembly is without an engine, wings, landing gear, rudder and stabilator.

Fuselage assemblies are transferred from the mating jig to special holding dollies. These dollies, as you will note in Figure 106, have small wheels which fit into and are guided by tracks that keep each dolly moving in only one direction. Almost immediately after being placed on dollies, the fuselages are wheeled over to the 2787 area—the final fuselage line.

As the fuselages roll down the line, they first receive a vertical fin and then other necessary equipment, such as control wheels, rudder bars and pedals, and cables which will move the aircraft's control surfaces (ailerons, rudders, flaps, and stabilator). This procedure continues until the fuselages are near the end of the 2787 area where the stabilators are attached and linked to the appropriate cockpit control device. Also note that this action occurs just before the engines and nose gear are attached. Soon after the fuselages receive their engine/nose gear assemblies, the dollies are moved to the final airplane line.

Now look at areas 2774 and 2772. In these areas, sub assembly work is done for the parts that will be attached to the airplanes as they move toward the end of the final airplane line. Beginning at the upper

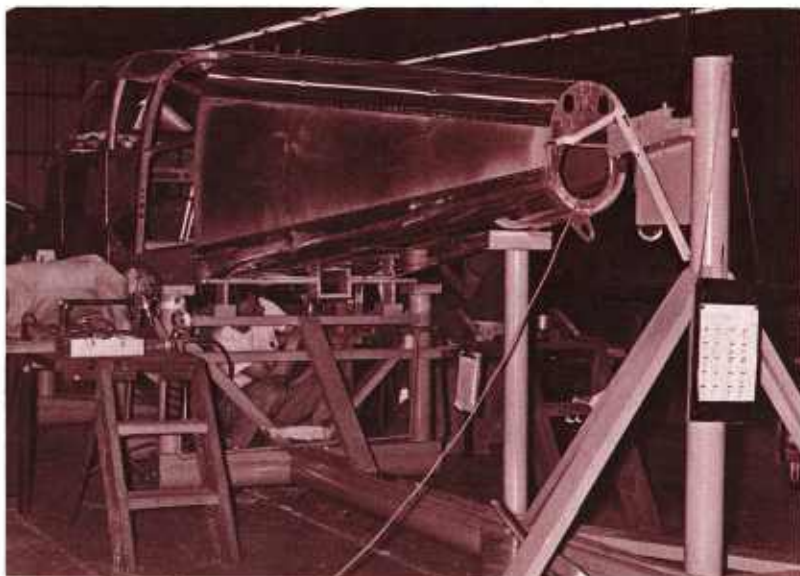

FIGURE 105 Mating 3 sections of fuselage

portion of area 2774, you see that a wing's skeleton starts with spars. The spars are the wing's main support, and to them are attached the ribs, stringers, skin and other items of which the wing is made.

Somewhat like the fuselage, the wing is constructed in sections, and the sections are joined together in mating jigs. After spars are drilled to receive bolts and rivets, ribs and stringers are attached to them, along with wheel wells if the wings are intended for planes with retractable landing gear. Each wing section—aft, leading edge, and root—meet at the appropriate wing assembly mating jig where all three units and a fiberglass tip are joined.

In area 2772, parts and units for wing assembly operations are made and delivered to the wing assembly. It is in the 2772 area, as you will note, that the fuel tanks are made. A special sealant is applied to the seams to keep the tanks from leaking. After each tank is sealed, it is tested thoroughly to insure that leaks will not develop through normal use. The tanks are then installed in the wings, and the completed wings advance to the last station in area 2774 where the landing gear are attached. At this point the wings are moved to the final airplane line (area 2788).

Soon after the wings are “hung” to a fuselage, the flaps and ailerons are attached. Each craft, really looking like an airplane now, is slowly

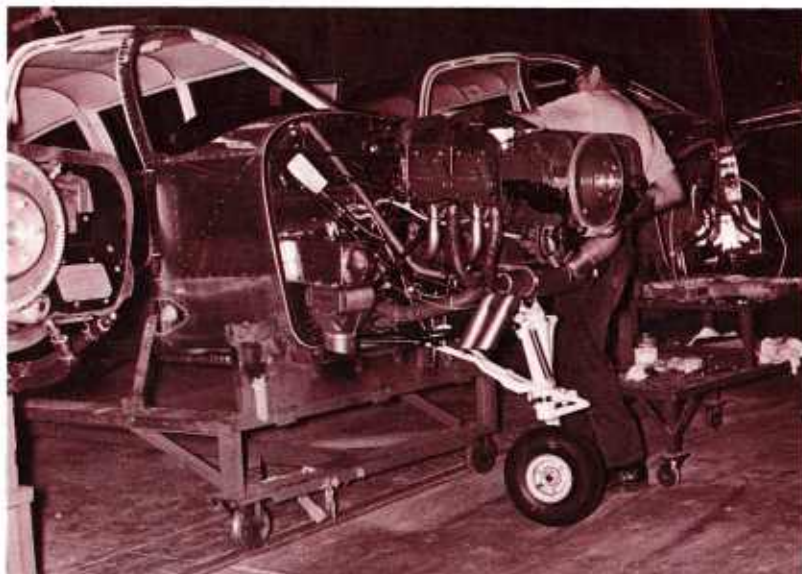

FIGURE 106 Hanging an engine

inched toward the exit door. Every foot of the way brings another part or adjustment to a part. Propellers are attached to the engines. Frames for the windshield and windows receive their contoured plexiglas. Electrical harnesses are hooked up. Vacuum machines remove small pieces of aluminum, plexiglas, cloth and other debris which have fallen into crevices here and there.

The last major action on the final airplane line comes when instruments are moved from area 2553, attached to the instrument panel, and connected to tubes and electrical wires. When this is done, the airplane receives a final inspection, and a packet is prepared which contains a copy of all travelers along with charts showing which inspections have been performed on the airplane up to this time.

The large door at the end of the final airplane line is opened, and another new airplane rolls out to the ramp area to be preflighted. The engine receives its oil supply, the wing tanks are filled with gasoline; controls, brakes, flaps, etc., are all checked to see if they operate properly. Of course, the engine is run for a period of time and at various throttle settings to see if it performs properly.

After preflighting, the still silver-colored bird is released to a test pilot. At this point the pilot makes a personal walk-around inspection of the airplane, checking such items as the proper movement and attachment of control surfaces. All the while he is noting on a test flight report form anything that isn't perfect. This process continues when the pilot enters the aircraft and checks the performance of certain instruments after he starts the engine and begins to taxi for take-off. Throughout the test flight, the pilot notes how the aircraft responds under varying conditions. Upon landing and if the airplane needs a major adjustment or a part replaced, the test pilot sees that the airplane is taken to a special modification area where such work is accomplished.

Airplanes that do not have to go to the modification area are cleaned thoroughly and moved into area 2762 for painting (Figure 107). A huge turntable is the hub of the painting operation. When an airplane is placed on the turntable, specialists go to work masking off all parts that will not receive paint (windshield and windows, tires, etc.). Afterward, the airplane is placed in one of the spray booths and on a special lifting device so that it can be elevated and the underside spray-painted.

This first session in the paint booth applies the basic coat only. The basic coat dries, and the airplane is again moved to the turntable. The



FIGURE 107 Masking trim; painting

second time on the turntable involves very careful application of masking so that the various colors of trim paint and large identification numbers will be perfect. After the trim and identification numbers have been spray-painted, the remaining masking is removed, and the airplane is moved outside area 2752 for inspection and “touch up painting.”

### AIR WORTHINESS CERTIFICATION

When an airplane comes out of the paint area, it appears to be perfect. But it's a long way from it. The “final touches” and inspections are yet to be done. Again, if you will note in Figure 103, the airplane is shunted to another area, No. 2791. Here technicians install the remaining upholstery and other final items. All the while a very elaborate inspection process is going on because this is where the airplane is certified as airworthy in accordance with standards established by the Federal Aviation Administration.

The very last step prior to delivering an airplane to its new owner is a final test flight. If all systems perform as intended, the airplane joins others that are waiting to be delivered to, or picked up by, their owners.

Many airplanes are sold to purchasers in foreign countries the world over, and they have to be delivered. Transporting these airplanes involves extra work because they certainly can't fly to their destinations under their own power. The distances are too far, and too few, if any, airports for landing and refueling may exist between the plant and the delivery point.

All of this means that surface transportation has to be used. For those airplanes going to some countries, special wooden crates have to be built to hold and cradle the fuselage, wings, and other components. As you can imagine, the crates must be exceptionally sturdy so that the airplane will not be damaged. Just how far the plant will go in completing components will be determined by the airplane's destination. Components will be shipped practically bare if the company has established assembly stations in the country to which an airplane is shipped; however, the great majority of these components are shipped requiring little more than to be attached to the fuselage.

If an airplane is going to certain other countries, it may be shipped in a steel container like the one shown in Figure 108. Two Piper single engine aircraft can be shipped in this tamper-proof and practically indestructible container which can travel nicely on railroad flatcars to dockside for loading aboard ship.



FIGURE 108 Shipping container

This container can be hoisted directly from the railroad flatcar, or flat bed truck, and placed into the ship's hold. This process is reversed when the ship arrives at its destination. Shipping aircraft by this means simplifies crating and handling processes, and insures against damage and theft.

## MANUFACTURING SUPPORT FUNCTIONS

As we discussed the procedures for building a Piper airplane, a few support functions were mentioned. Recall the various references to travelers and blueprints and recall that these items had to be delivered to the various work stations. The act of delivering the travelers and prints is a support function. The personnel who do all the typing are providing a support function. Many other personnel are involved with support functions, too. Someone has to guard the plant's facilities, and someone has to keep the plant and various offices clean, etc.

Support functions, we can say, are all those tasks that must be done to keep the manufacturing process going, but which are not directly involved in building the airplanes. In fact, there are complete operations within the manufacturing organization which fulfill a support role. Let's discuss some of these operations.

**QUALITY CONTROL.** This is a special department which essentially is the watchdog for the company and for the Federal Aviation Administration. It is charged with insuring that every part, every assembly, and every airplane meets established standards for quality in production and performance.

As we were discussing the steps in the actual manufacture of an airplane, we made brief mention of inspection. It can be reiterated now: Every one of those many, many steps was accomplished under the careful scrutiny of quality control *inspectors*. Remember the section about the making of special production tools? Each of these tools is inspected before it is put to work. Even samples of raw materials (coil aluminum, for example) receive spot-check laboratory analysis.

Nearly seven percent of the manufacturing organization is responsible only to the quality control function. This percentage includes the test pilots because quality control personnel must be "outside" the manufacturing structure. Otherwise they theoretically could be influenced to be lenient and let a few substandard parts get by. And this could result in tragedy not only for the customer but also for the company because if a substandard part proves to be the cause of an accident, the company could be legally liable.

Liability, then, is another of quality control's responsibilities. This is one of the reasons why all the "travelers" and inspection sheets are kept for a period of years after an airplane is delivered to its owner. If the airplane does not perform properly and is destroyed, its records can be checked for a manufacturing error.

Finally, quality control plays a role in how future manufacturing processes will be accomplished. This role involves recommendations for product and process improvement. Since the people who work as quality control specialists (inspectors) mostly are former production workers themselves, they are experts at what they are doing and can give expert opinions. Their opinions flow in to the central quality control office where they are compiled into reports aimed at improving the whole airplane.

**MARKETING AND SALES.** It doesn't matter how many airplanes are produced per day or how good they are—if the people who buy airplanes do not know about them, they will get no farther than a few hundred yards beyond the final airplane line. Hence, marketing and sales are the keys to the company's success.

Marketing and sales experts decide what colors the airplanes should be to make them most appealing to potential purchasers. Oddly enough, the public's attitude as to what "looks good" (is stylish) changes periodically, and close tab must be kept on this attitude. Much time and research go into just this aspect of marketing and sales. When what the public likes in color combinations is known, marketing and sales experts decide how these colors will be applied, especially to the trim design, so as to have the widest appeal. For instance, most people like things that go fast, whether boat, automobile, or airplane, and people associate airplanes with speed. (The most often asked question of a new automobile owner is "what will it do?") An airplane, sitting on the ground, can be made to *look* speedy simply by the way its trim design is applied.

Advertising media convey the airplane's virtues—in words and pictures—to the nation and the world. This takes money—lots of it—and many talented personnel. Brochures in full color must be printed to show the airplane both in flight and snugly tied down at faraway places that are nice to fly to. For pilots, advertising literature must include accurate accounts as to how the airplane will perform—how high and fast it will go, and how little space it needs for take-offs and landings.



FIGURE 109 Aerospace personnel

In addition to brochures, ads must appear on television, on the radio, in newspapers, and, most important, in magazines. Today there are almost one million licensed pilots in the United States. Add to this number several million more people who are interested in flying and the aerospace industry. For these millions, special magazines provide an excellent medium by which an airplane manufacturer can get his message to potential customers.

Signs and leaflets must be prepared for the hundreds of dealers who sell airplanes for the manufacturer, and various programs must be developed for dealers to use in getting people interested in the airplane. Inexpensive introductory flights are one example. Special flight training programs are another.

When purchasing a new airplane, the customer usually wants special items on it. Perhaps he wants additional radio or navigational equipment, and he may not like available trim colors and may specify the color he likes best. These types of special orders are part of the marketing and sales job; so are any complaints that the customer may have if the complaints are not resolved at the dealer level.

We could go into much more detail about the responsibilities and problems that are common to this part of the organization, but our

purpose is to give you only a general knowledge of how the system operates.

**PERSONNEL.** This is the short title that we will give to the department that keeps up with all things that have to do with the human beings who make the airplane. In some companies, this function may be called industrial relations, or employee relations, etc.

Specialists who work in the personnel department are concerned with tasks such as "hiring and firing." But their main efforts—and those of everyone else associated with the industry—are directed toward making a better airplane. To do this, special programs must be developed which insure that workers have the best on-the-job training possible and have the opportunity to further their education.

When problems develop between the workers and their supervisors (management), it is Personnel's responsibility to mediate the differences and bring about a settlement agreeable to both interests. This process becomes more involved and complex if the workers belong to a union. In short, Personnel must see that the workers and management get fair treatment from each other.

A continuing safety program shields workers from possible injuries, and adequate compensatory arrangements are provided for those to whom the "impossible" accident happens. Performance evaluation programs, on the other hand, monitor the quality of work that an employee accomplishes and lets both the employee and management know if the job is going as it should. If it isn't, both parties know what actions should be taken to correct the situation.

In short, Personnel has to keep its finger on the pulse of the entire human being/machine complex and do everything possible to keep the manufacturing processes going smoothly.

# CHAPTER 5



FIGURE 110 C-5 "Galaxie"

**BUILDING THE BIG BIRDS**

The greatest differences found in a comparison of building giant transport aircraft and booster rockets to that of building small aircraft are size, number of parts, special capabilities, plant facilities and number of construction personnel. After all, airplanes have similar features—fuselage, wings, empennage, power plant, instruments, etc. Control devices and control surfaces are similar, too, but the methods used to operate control surfaces will vary considerably. Yet, bigness is the overriding and most obvious difference.

Since you are familiar with the more or less detailed steps of building an airplane, we will be very general in this chapter dealing with the construction of the “big birds.” And the big birds that we will talk about are the USAF C-5 “Galaxy,” which was developed primarily by Lockheed Aircraft Corporation, and the Saturn V launch vehicle which was a joint NASA/industry effort.

### THE C-5 GALAXY

Need, again, was the impetus for building the C-5 transport. Always there has been a need for military forces to be as mobile as possible with the least amount of fatigue to people and machines. With the advent of more and more rapid modes of transportation and the probability and possibility that widely separated geographical areas would be the scenes of contact between opposing military forces, the need to transport troops and equipment quickly to far-flung places demanded the development of a giant airplane. Therefore, the industry was asked to design an airplane which could transport almost any type of military equipment together with a large number of troops. In addition, the airplane would have to travel at high speeds, fly long distances, land at relatively low speed, and be able to land and take off from primitive airstrips. Quite an order for engineering and production personnel to fill!

The design which the engineers decided would do the job was an airplane with a fuselage 247.8 feet in length, a wingspan of 222.8 feet, a height of 65 feet, and an ability to fly with a maximum cargo weight of 265,000 pounds at 500+ miles per hour.

As you can imagine, a vehicle of these proportions posed some unique problems for its builders to solve. Recall that a Piper four-passenger light airplane is constructed mostly of aluminum alloy with some steel. The C-5 designers and builders had to come up with a great variety of metals which could provide strength enough to support

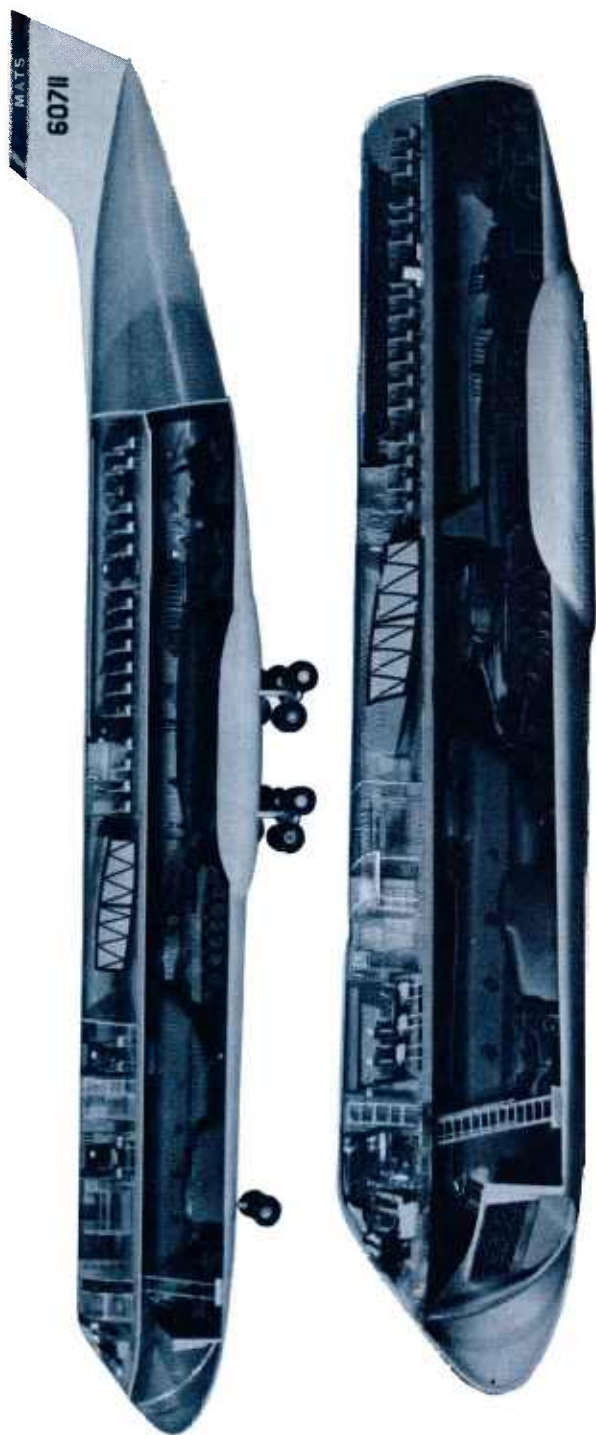

FIGURE 111 Interior view of C-5 "Galaxy" fuselage

the heavy army trucks and tanks that the airplane would have to transport. At the same time, the engineers had to be very weight-conscious, so they used a combination of metals. The combination included aluminum alloy for the major portion of the airplane's basic structure and skin, but 50,000 pounds of high strength steel went to make up castings for landing gear parts and the floor or main deck structure. Beryllium forms the brakes. Titanium was substituted for certain parts, including tracks for leading edge slots, splice plates, and "fail-safe" straps. Where feasible, magnesium was used to help offset the weight of necessary heavier metals. Even depleted uranium alloy provided suitable counterweights for some of the airplane's control systems. Finally, and again like the small aircraft, the gigantic C-5 has many parts that are not made of metal; plastics were substituted.

An airplane of this size and mission had to have some "never-before" features built for it or into it. Let's examine them:

*Engines:* Specially built turbo fans (4), each having an inlet diameter of 8 feet and producing over 41,000 pounds of thrust. (Furnished by General Electric Co.)

*Hydraulic system:* Eight engine-driven pumps provide hydraulic pressure of 3,000 pounds per square inch to move the huge control surfaces at the pilot's command. Backup pump is a ram-air turbine to be used in the event regular pumps malfunction.

*Malfunction detection:* System which uses special sensors and computers to detect and prescribe corrective measures for any of the other systems that might have even a minor malfunction.

*Landing gear:* Consists of 28 wheels which distribute the weight of the airplane over a large area and allow it to land on different types of surfaces. Another special feature of the landing gear is that it can be adjusted, or pivoted, so that the airplane faces directly into the wind when landing and taking off in a crosswind. This keeps the airplane from drifting with the wind. Smaller aircraft compensate for crosswinds by, for instance, lowering a wing into the wind, but the C-5's wings have a large negative dihedral—that is, they droop toward the ground. Any lowering of a wing in landings or takeoffs would be extremely dangerous. The C-5 therefore is designed to assume a "crabbed" position—it can land with its wheels pointed straight down the runway while the plane is apparently headed off to the right or left at various angles up to 20°.

*Self-elevating:* The landing gear assemblies are unique. The entire aircraft can be elevated or lowered to facilitate the loading of its

cargo. Since each assembly operates independently, the airplane can tilt forward or backward. Any one of the landing gear assemblies can also be lifted off the ground to allow a tire change.

*Self-weighing:* Two very important aspects of an airplane's ability to fly and maintain safe flight are, one, how much its cargo weighs, and, two, how well the cargo is distributed. The C-5 provides this information to its crew automatically. Transducers are located in the landing gear, and the amount of weight pressure being applied to the gear is converted by an on-board computer to a read out for the crew's use.

*Auxiliary power:* Since the huge airplane operates from remote locations, it had to have special auxiliary power units which provide electricity and compressed air for the operation of many subsystems including air conditioning and the hydraulic system.

Now, you can see that the C-5 differs considerably, even in special features, from other, smaller aircraft. But what about the actual building of such a big bird? The same processes are used as with smaller aircraft. It just means that larger jigs have to be used, and it takes more workers to accomplish fabrication and assembly tasks. In addition to this, more and larger equipment is obtained from other companies. Too, fabrication and subassembly of C-5 components doesn't take place under one roof.

FIGURE 112 Prime contractor

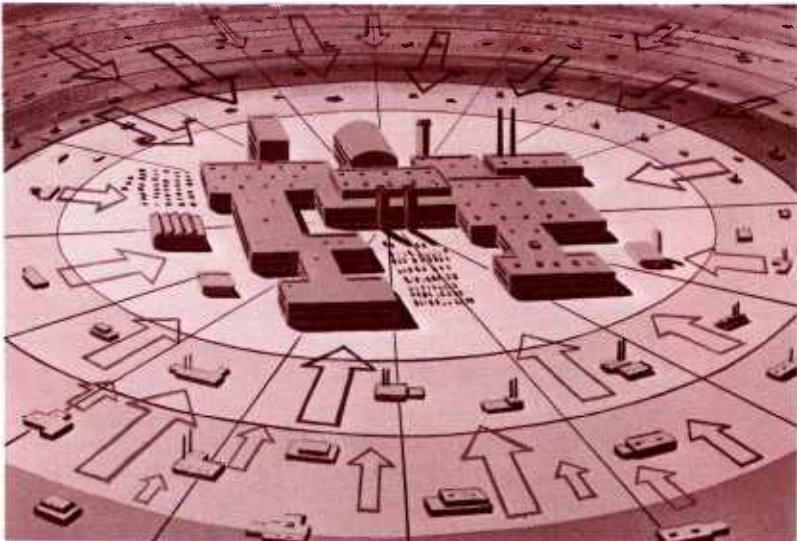

The airplane's wing and landing gear are constructed at and come from locations in the U.S. midlands. The empennage (tail) and nacelles (engine covers) come from the Pacific coast. Electronic equipment comes from the Northeast. Actually, it takes more than 2,000 subcontractors and suppliers to get together all the parts and materials that are needed to build the C-5, and this directly involves workers in forty states, the District of Columbia, Canada, and England.

All of these parts, assemblies, and special equipment come together under Lockheed's giant, 75-acre (floor space) main assembly plant at Marietta, Georgia. The wings, empennage, landing gear, etc. are mated to the fuselage in a process remotely similar to that of the final airplane assembly line in small aircraft manufacture. Afterward come the hours and hours of ground and flight testing before each big bird is delivered to its owner—the United States Air Force.

Although a limited number of C-5 airplanes will be built for military use, the airplane can be applied to civilian uses. For example, the C-5 in civilian configuration could transport about 500 passengers, or it could transport as many as 63 standard sized automobiles. But this airplane is only the start. Its technology and construction techniques have paved the way for the building of even larger aircraft—when there is a need to do so.

## THE SATURN V LAUNCH VEHICLE

One of the latest challenges to our nation's engineers and manufacturers was how to build a launch vehicle powerful enough to defy Earth's gravity and send a three-man spacecraft to the moon. By mathematical computations, the planners could determine how much thrust it would take to accomplish the mission. Also they found that the launch vehicle should have three separate stages, with the spacecraft assembly attached to the last, or third, stage. Over all, the big launch vehicle would have to stand 282 feet tall—including its engines and the special instrument unit which would ride atop the third stage, forming the link between the booster assembly and the spacecraft assembly. The diameter of the first and second stages would be 33 feet, and the diameter of the third stage would be 22 feet.

You must remember that all of these "conclusions" did not come about over night. The National Aeronautics and Space Administration's scientists, engineers, technicians, and managerial personnel worked for several years to evolve the giant machine. They had to

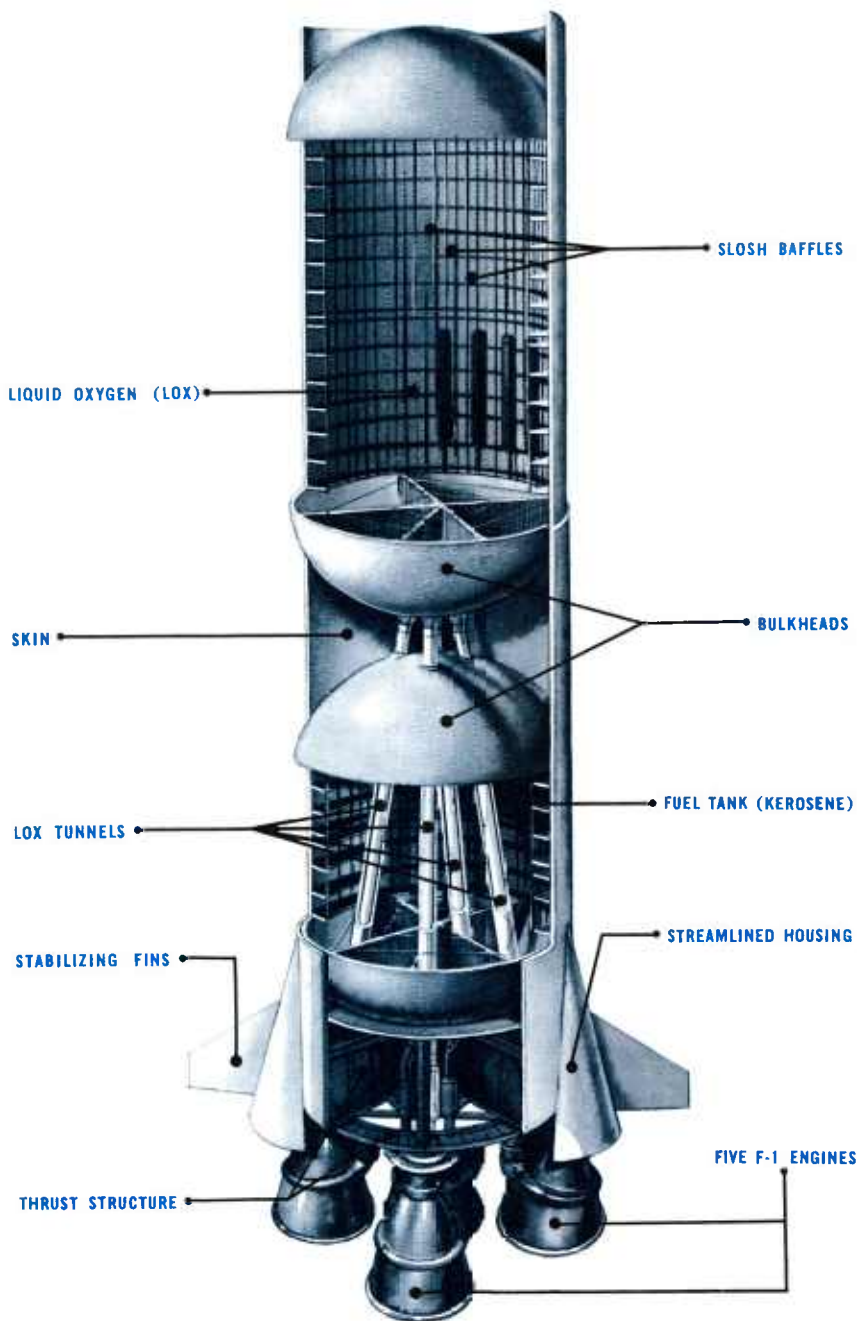

FIGURE 113 First stage of Saturn V launch vehicle

take their paper theories and turn them into hardware, and the hardware had to be static (non-flight) tested over and over again. So this meant that they had to design and build the test devices, too.

NASA's Marshall Space Flight Center personnel actually developed the manufacturing processes and test facilities for the first stage of the Saturn V system, and they built the prototype and early flight models. As these new techniques were developed, manufacturing plans were written in which were given step-by-step instructions for the fabrication and assembly of each part. The manufacturing plans served as a model for U. S. aerospace industries which contracted to build the Saturn system.

All rockets use propellants which are composed of a fuel and an oxidizer. The oxidizer is the agent which provides oxygen to be mixed with the fuel so that burning and consequent energy, or thrust, will occur. The most efficient propellants yet devised for booster rockets are in liquid forms, so separate tanks with the capacities to store huge quantities of fuel and oxidants make up the bulk of such rockets. The problems inherent in building these tanks involve size, strength, and weight.

In the case of the Saturn booster, the first and second stage tanks have, as we have said, diameters of 33 feet. The tanks must have the structural strength to withstand the pressures of the fluids within them and the downward pressures of other rocket and spacecraft structures placed above them. With all these requirements for strength, the tanks still have to be "relatively" lightweight. Aluminum, in various alloys and forms, was found to be the best structural material. To put together the pieces of large aluminum fuel and oxidizer tanks required unique approaches to the "art" of welding and milling aluminum. Before we talk about these processes, let's see what constitutes the Saturn's first stage.

Beginning at the very bottom are five huge F-1 engines which are attached to the *thrust structure*. The thrust structure is a complexity of beams and bracing constructed mainly of aluminum alloy, along with some steel. Surrounding the thrust structure framework is a skin assembly which adds strength and provides for better aerodynamics. Other aerodynamic features attached to the thrust structure are engine fairings for the four outboard engines and the fins which are attached to extend outward from the engine fairings. As a note, these fins are

FIGURE 114 F-1 engine

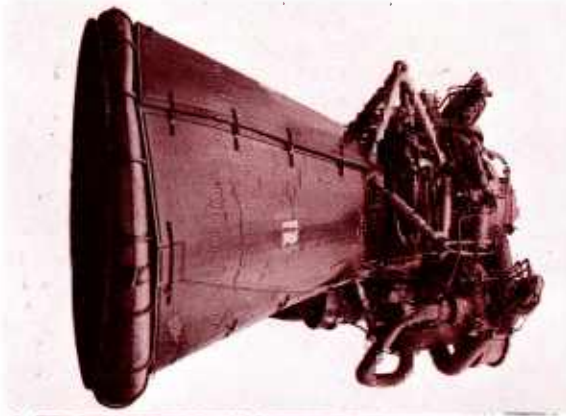

FIGURE 115 First stage, Saturn V, showing thrust structure

added insurance for stability of the rocket's flight. The engines are gimballed and are constantly adjusting their directions of thrust so that flight stability and directional control are maintained, but the fins can help toward this function for the short time that the rocket is still within the atmosphere.



FIGURE 116 Skin sections & bulkheads

The huge fuel tank is made up of three basic assemblies: the upper and lower bulkheads and the skin. Each of the bulkheads has special fixtures attached to it so that the tank contents can be delivered to the engines. For instance, the fuel tank's upper bulkhead has five special fittings for apertures through which liquid oxygen (LOX) tunnels pass and continue through the fuel tank, emerging through special fittings on the lower bulkhead. At the lower bulkhead, there are ten other aperture fittings through which fuel is suction-pumped to the engines. In addition to LOX tunnels within the fuel tank, special slosh baffles are placed along the sides and lower bulkhead. These keep the liquid fuel from swirling as it empties from the tank and from sloshing back and forth and setting up a rhythmic force that could cause an uncontrollable change in the booster's flight path or cause structural failure of the tank.

The tank's bulkheads are composed of eight "gores." Construction starts with thick sheets of aluminum alloy. Each "gore" is made in two sections—the apex and base. The gore sections are bulge-formed so that each is very near the curved contour required for it to fit with the other gore section and with adjoining gores. These apex and base gore sections are placed in special jigs so that the edges where they fit together can be trimmed to exact dimensions. For those gore sections which have to have special fittings, the fittings are first welded in place, and the sections receive a special heat treatment to bring the temper of the metal to where it should be.

After heat treating, trimming, and fixture welding operations are completed, the base gore section and apex gore sections are held by another special jig and welded together and then trimmed again. When the eight gores are completed, they are moved to a huge turntable jig where two adjoining gores are first held together and welded to each other. After the initial two gores have been joined, remaining gores are moved in place and welded. This leaves a "hole" at the top, or apex, of the bulkhead assembly, and it is filled by welding in place the center piece. At this point the bulkhead assembly's bottom edge must be trimmed for fitting with what is called the "Y" ring.

The Y ring is a special adapter which permits a smooth transition from the curved bulkhead structure to the cylindrical tank wall structure. The tank wall—or skin—also is made of aluminum alloy. The skin begins as thick aluminum alloy plate sections which are so heavy that they are placed in gigantic milling machines where the unneeded amount of metal is milled out. The milling process "ribs" the inner structure, leaving a smooth outer skin with sufficient strength and with much lighter weight. The ribs run vertically, and the skin sections are formed fairly easily to the desired contour. Skin sections thus prepared are placed in a holding jig and are welded together, forming *one* complete cylindrical skin assembly. (Depending on the height desired for the tank, these cylindrical skin assemblies can be stacked one on top of the other, with welds making a permanent bond between them.) When an assembly is completed, the slosh baffles are attached to the interior.

Very well, these are the basic manufacturing processes involved with making bulkheads and skin assemblies for the Saturn first stage fuel tanks. The next big task is to put together all of these huge parts and form the completed tank. Beginning with the Y ring, the bulkhead is lifted from the turntable and the Y ring is placed on the turntable. The bulkhead is lowered gently to the Y ring, and the lowering is continued ever so slowly while the two units are adjusted for perfect mating. Afterward the Y ring and bulkhead are welded together. (Note: The same process is followed for both the upper and lower bulkheads.)

As stated earlier, the Y ring is the link or adapter for the joining together of the tank bulkhead to the tank skin. Since, at this point, the Y ring is ready to receive a skin assembly, the bulkhead Y ring is hoisted from the turntable, and the bulkhead assembly is then lowered to the skin assembly so that both units can be welded together. This process

is continued until the upper and lower bulkhead assemblies have welded to them the number of skin assemblies needed to form the two halves of the fuel tank.

The two tank halves are transported to a vertical assembly area where they can be joined. This process involves placing the lower half of the tank into another turntable jig, and lowering the upper tank half into position so that the final assembly weld can be made. The next operation is to lower into the completed tank shell the five liquid oxygen tunnels (one at a time) and perform the necessary welding and bolting operations to keep them in place. We should backtrack a bit and say that the lower bulkhead—before the tank halves were joined—has a semi-spherical foam “riser” adhered to it. This helps insure that the fuel will empty from the tank evenly and completely.

At certain points all during the construction of this huge fuel tank, many tests are made. Careful examinations must be made of all welding operations that are performed. This is accomplished through X-ray techniques which reveal imperfections. Such imperfections can be corrected by grinding away enough metal to allow rewelding of the affected area. Ultrasonic techniques reveal the thicknesses of gore sections after they have been formed. Hydrostatic tests reveal whether an assembly will withstand the pressures that will be applied to it during actual operation.

The final preparatory steps involved with constructing the fuel tank are to make certain that it is clean and that it is protected from corrosion. In a highly controlled environment, all contaminants are removed from the tank, and a protective coating is applied, and the unit is sealed off from possible incoming contaminants. This process requires sealing off the area around the tank so that only filtered air is within the tank area. Filtered air under pressure is pumped into the tank. This means that all “old” air is forced out of the tank’s interior, taking with it any contaminants such as dust. Air outside the tank’s interior, at lower pressure, can’t seep into the tank. While air in the tank is still under this greater-than-atmospheric pressure, probes are inserted into the tank to (1) spray the interior with a cleaning fluid, (2) rinse the fluid away with demineralized water, and then (3) apply the special protective coating to all interior surfaces. After the protective coating is applied, all apertures—openings—are sealed, and the exterior of the tank is painted. It is now ready to be joined to other huge units that make up the booster system.

The liquid oxygen tank is constructed in a manner similar to the fuel tank. That is, the bulkheads, skin sections, slosh baffles, etc. are fabricated and assembled. The completed tank is then cleaned, coated, sealed, and its exterior given a coat of paint. One additional fixture which goes into the LOX tank is a system of helium bottles. The pressurized helium maintains the tank pressure needed to help keep the oxygen in a liquid state and press it downward to the LOX lines. After the Saturn's engines are running, this needed pressure is supplied by gaseous oxygen that is fed back to the tank from heat exchangers in the turbine exhaust outlets of the engines.

The two tanks (fuel and oxygen) are joined together by what is called the intertank assembly. Simply stated, this is a large connecting ring which also measures 33 feet in diameter and stands almost 22 feet tall. It is made of aluminum sheets that are corrugated to provide

FIGURE 117

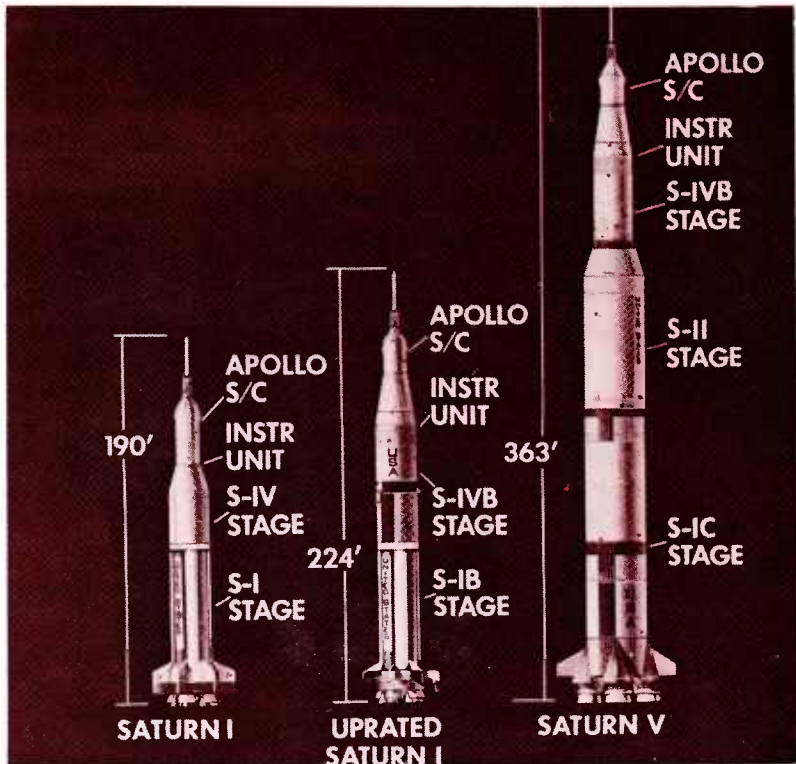

greater strength while maintaining light weight. Attached to the interior of the joined sheets, or panels, are "H" rings running around the circumference to help maintain the proper shape while giving it the additional strength which is the structure's most important feature. Although the fuel and oxygen tanks are joined together by the connecting LOX lines, it is this intertank structure which provides the needed rigidity and transfers the weight-lifting thrust from the engines to the rest of the vehicle's assemblies.

At each extremity of the intertank structure, special fittings provide the necessary linkage into the upper Y ring of the fuel tank and lower Y ring of the oxygen tank.

Another ring structure similar in configuration to the intertank structure is attached to the upper bulkhead of the LOX tank. This structure, the "forward skirt," is the linkage between the Saturn's first and second stages.

The second stage is 33 feet in diameter, but it is somewhat shorter than the first stage. Construction techniques for the second stage are similar to those used for the first stage, but there are great differences, too.

Where there are two separate tanks to contain the fuel and oxidant for the first stage, there is a single tank—so to speak—in the second stage. We say single tank because the completed structure looks as if it is built as one. What actually exists is a *common* bulkhead that separates the fuel portion of the tank from the oxidant portion. The LOX portion is built as a separate spheroid assembly, and the cylindrical fuel portion fits over and is joined to it at its equatorial point. We should note here that the propellant (fuel and oxidant) used in the second stage is cryogenic—super cold—and that liquid hydrogen is the fuel.

Cryogenic propellants require sophisticated insulation, among other things, to keep them in the liquid state. (Liquid oxygen boils and becomes gaseous at  $-297.4^{\circ}\text{F}$  while liquid hydrogen boils at  $-423^{\circ}\text{F}$ .) Insulation is therefore very much in evidence throughout the second stage structure. An excellent example of the required insulation is part of the common bulkhead between the propellant tanks. The gores for this bulkhead, rather than being made of thick sheets of aluminum as in the first stage tanks, are made of fiberglass honeycomb faced on both sides with aluminum alloy skin. This insulating separation between the two cryogenic liquids also gives high structural strength and light weight.



FIGURE 118 Construction of bulkheads

Once the propellant tank assembly is joined, more insulation is applied. Sprayed over the bulkhead of the fuel tank is polyurethane foam which hardens into a coat of effective insulation. This same material is applied to the exterior walls of the tank assembly, too. In addition, sheet cork is adhered to the polyurethane coating where it covers protruberances that extend into the airstream.

Other structures that complete the second stage are the interstage, which connects to the forward skirt assembly of the first stage; the aft skirt and thrust structure which are attached to the propellant tank and contain the five J-2 engines; and the forward skirt, which provides the link between the second stage and the third stage. Attached to the exterior of the cone-shaped thrust structure and to the interior of the forward skirt are many control and sensing instruments which tell how the stage is functioning and help regulate its performance.

The final stage of the Saturn booster system is designated S-IVB. Again the propellant tanks appear as a single structure because they share a common bulkhead. And, like the second stage tanks, these too are highly insulated. Beginning with the liquid hydrogen portion of the tank the internal surface is machine milled into a waffle pattern which maintains the stiffness (strength) required with as little weight as pos-

sible. Insulating polyurethane blocks are bonded into the milled areas. The common bulkhead is made of the same materials and in the same manner as the second stage common bulkhead.

Since the third stage is a great deal smaller than the second stage, the interstage has a conical shape with a 33-foot diameter where it joins to the second stage forward skirt, and a 22-foot diameter where it joins to the third stage aft skirt. The thrust structure holds the single J-2 engine, and attaches direct to the lower bulkhead of the propellant tank. Surrounding the thrust structure is the aft skirt which attaches to the propellant tank also, but at the point where the lower bulkhead and tank walls join. To the upper portion of the propellant tank a 22-foot-by-10-foot forward skirt is attached, and on top of it goes the 22-foot-by-3-foot instrument unit.

The instrument unit, in short, is the automated brains of all the structures that appear below it as the assembled booster stands erect. The skeleton of this unit has certain construction similarities to other assemblies. Its walls are of aluminum honeycomb "sandwich" structure so that both the exterior and interior surfaces are smooth. This smooth appearance is unlike the corrugated appearance of intertank, interstage, and skirt assemblies which lie below the instrument unit,

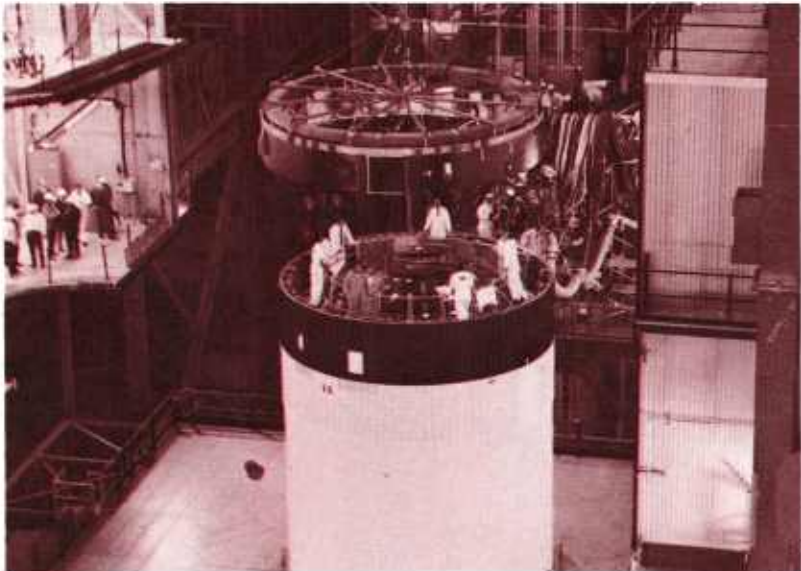

FIGURE 119

but the instrument unit does not have to support as much weight as the preceding structure. This allows much lighter weight materials.

Bolted to the instrument unit's inner surface are the various instruments needed to monitor and control every aspect of the booster's flight. The inertial guidance system provides information on the direction and speed of flight and whether the vehicle is stable. The computer system includes within its memory banks the flight path that the vehicle should take, how fast it should accelerate, and when the various stages should be separated from the rest of the vehicle. Deviations from this programmed flight are detected by other instruments, and are in turn fed into the computer system. The computer system compares the programmed flight sequence to the actual flight sequence, and, if corrections are needed, the proper signals are relayed to control devices which produce a change in the direction of flight or duration of thrust.

Also attached to the interior of the instrument unit are batteries which supply power to the electrical system, radio or telemetry transmitters, a coolant system consisting of ducts and plumbing, miles of electrical wire, and other components needed to keep the unit functioning. The unit, as you no doubt have deduced, has to be electronically connected to the lower stages and their components. Just this connective arrangement alone involves special construction features in the forms of tunnels and ducts which lie on the outside of and probe into various structures. Even after the first and second stages have fallen away, the instrument unit and the third stage go into orbit and await the exact moment when the two will perform their last function—that of firing the third stage and placing the spacecraft and astronauts on a trajectory to the moon. This final thrust is the culmination of many hours of thinking and doing on the part of scientists, engineers, and construction specialists from NASA and the aerospace manufacturing industry.

We will not examine even superficially the construction of the Apollo spacecraft system which consists of the command, service, and lunar modules. Suffice it to say that the same types and kinds of materials are used to build the spacecraft. The differences are found in the forms the materials take and in how they are put together.

What we do want to show you, however, is the effect that a construction program of the Saturn/Apollo type can have on a nation and its people. We said earlier that the National Aeronautics and Space Administration produced prototypes and some flight vehicles. Let us

now emphasize that the aerospace manufacturing industry from coast to coast also assisted NASA with the basic research, and it was the industry that fabricated the vehicles that now are flying and are yet to fly.

Some of the major contractors involved with building the Saturn/Apollo system include Boeing Aircraft, North American Rockwell, International Business Machines, Bendix Corporation, McDonnell/Douglas, Chrysler Corporation, General Electric Company, etc. But in addition to these major contractors, many other smaller companies took part in building the Saturn/Apollo system. Some of them, not primarily involved with the manufacture of space vehicles or major components for them, do become a part of the aerospace manufacturing industry to the extent that they build even small components for space vehicles.

Including the major contractors, 20,000 companies were/are involved with construction of the Saturn/Apollo system, and the project at one time provided direct employment for 350,000 people. This might seem to be an inordinate number of companies and employees even for a large vehicle, but consider these statistics: The Saturn V, which includes the first stage (S-1C), second stage (S-II), third stage (S-IVB), and the instrument unit, requires a total of 3 million parts. In the spacecraft itself there are over 3 million parts. The command and service modules together require 2 million parts, while the lunar module uses 1.1 million.

In summary, the huge Saturn rocket and the Apollo spacecraft are marvels of our time. To build such vehicles requires construction techniques that are common to those used in the manufacture of airplanes and other vehicles, but whole technologies have to be invented, so to speak, because the job to be done had no precedent. Tremendous size, too, is a factor that has to be reckoned with. This brings about the requirement for oversized jigs for the construction of components, tremendous assembly and test facilities, and highly complex launch facilities. What has already been learned will provide the basis for the development of new, possibly larger, and more efficient space vehicles. The building and flying of such vehicles provides employment to thousands of workers representing many types of skills and industries. But of most importance, space exploration adds to our knowledge of the universe.

# CHAPTER 6



FIGURE 120

## SUPPORT INSTALLATIONS AND DEVICES

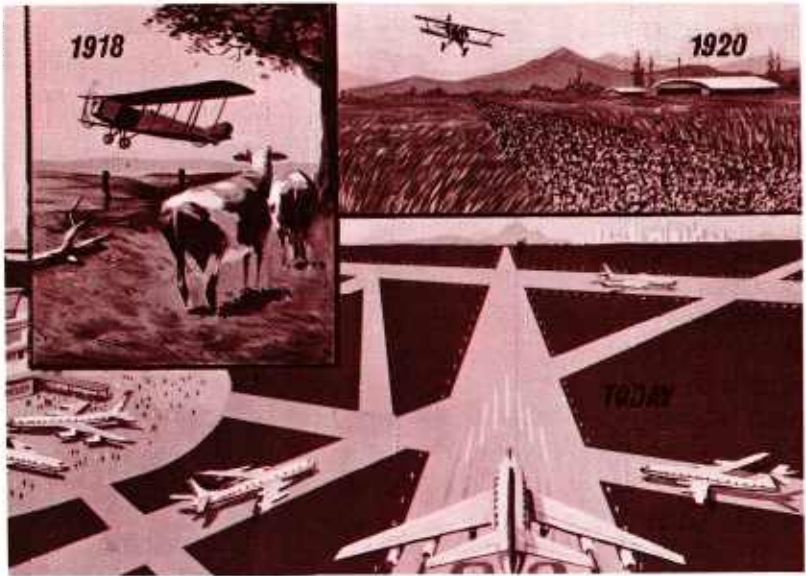

FIGURE 121 Airport evolution

When we see aircraft flying overhead or see space vehicles leaving their launch pads, the fact of the flights usually is all we think about. We seldom wonder how much activity preceded the flights nor what facilities had to be used to launch the vehicles. Yet, without proper support installations and devices, the vehicles could not fly.

Just a few years ago, a pilot and his airplane needed only a pasture to take off and land. Sometimes a dusty county road was his airport. Rockets were toys launched from bottles. Things have changed, though, and much more “behind the scenes” activity is required.

For a moment, let's go back to the plant installations where airplanes and space vehicles are built. Recall that it takes huge buildings to house the fabrication and assembly phases of small aircraft manufacture. Much larger plant facilities are needed to construct a Lockheed C-5 or Saturn rocket. And into these plants must be placed special light fixtures, air conditioning units of tremendous capacity, special conveyor systems, special tools, and so forth. It takes these types of complex support installations and devices just to build the craft. This is only the beginning. After the craft leaves the manufacturer, most of the many required beyond-manufacture support installations and devices are provided by the aerospace manufacturing industry.

## AIRPORTS

Airports vary in size and facilities according to their locations and purposes. Some are very small—not much improved over the “cow-pasture” type—while others are tremendous. The smallest airport usually consists of one 2,500-foot runway; a single building which houses the airport manager’s office; a large hangar (maybe) where airplanes can be repaired; small “T” hangars to protect individual airplanes from the weather; devices for determining wind direction and velocity, the temperature of the air and the relative humidity; and a lighting system for the runways and taxiways.

Runways, taxiways, buildings, and hangars are built by local contractors who do general construction work. But all the other items and devices involve the aerospace manufacturing industry. Let’s start with the runways and taxiways, prefacing our discussion with the fact that, because airplanes need to take off and land into or facing the wind as much as possible, runways are laid out so that they will be lined up with the average direction of the wind.

Specially designed lights are placed along the edges of runways and taxiways for pilots who may take off or land after dark. These specially built lights have to withstand all types of weather, and they must be of different colors. White lights (they really have an amber appearance) outline the active runway, and blue lights outline the taxiways which lead to and from the runway. Rotating beacon lights are located at many airports to tell pilots whether the airport is for civilian or military aircraft.

Other types of lights are used also. High intensity flood lights illuminate the ramp areas (parking areas); light guns that project different colored light signals are used to transmit special predetermined messages to pilots who may not be able to communicate by radio, and lights outline the devices that show pilots visually the direction the wind is blowing at ground level.

Manufacturers produce three different types of devices which show the wind direction at ground level, two of which—the tetrahedron and windtee—may be lighted at night. The tetrahedron looks like an elongated pyramid on its side, and the apex or point is always toward the direction from which the wind is blowing. The windtee is in the shape of the letter “T”, and the “vertical stroke” of the tee points out the direction of the wind’s origin. Finally, the wind sock is a sleeve-like, unlighted, fabric device. It has a rather large opening at one end and tapers to a fairly small opening at the other end. The sock’s large end

is affixed to a metal ring. The entire sock can rotate freely so that the large opening catches the wind, and therefore, always faces the wind. According to the velocity of the wind at the moment, the sock may be flying either straight out (parallel with the ground), or it may look fairly limp. If it is flying straight out, pilots know that the wind is blowing very hard, and that they should be especially careful when taking off or landing.

Still at the small airport, we find that almost everyone has a radio transmitter and receiver (transceiver). This "aerospace" equipment is most useful to the airport manager and to pilots. Even though the small airport does not have a control tower, pilots can ask for essential information about wind and other conditions long before they come within sight of the airport. In like manner, a pilot about ready to take off can ask the airport manager, via his radio, for an advisory on airport conditions at the moment. He will be told which runway to use, and from what direction the wind is blowing and how fast. He will also be told of aircraft approaching so that he can look for and avoid coming too near.

Some manufacturers produce specialized equipment that is used exclusively on aircraft while they are on the ground. Among this equipment are riveting guns for repairing airplanes, special hoists and cra-

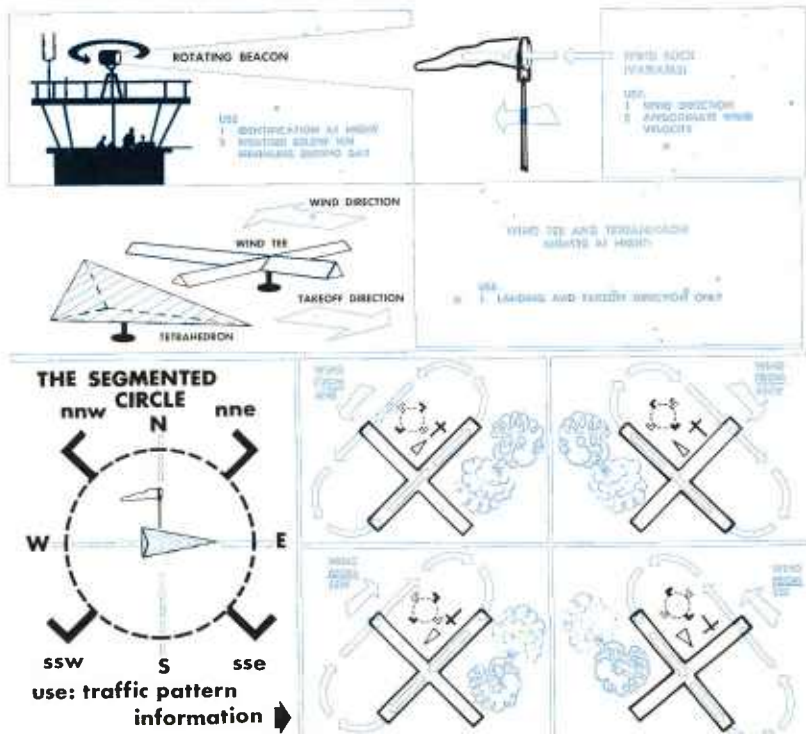

dles which are used to remove and replace engines, special tools for making engine repairs, and so forth. Auxiliary electrical power units are available for starting engines when needed; these can be towed to or driven to the airplane. The airplanes themselves often require towing when it is not essential, or practicable, to start the engine(s). Most airplanes are small enough so that one person can use a specially made tow bar to pull the airplane out of hangars or over short distances. When the larger twin engine airplanes land at small airports, one person can't tow them very easily, if at all, so manufacturers provide wheeled tow bars that use a small engine to provide the needed power. Very big aircraft at large airports are towed by special tractors.

When we go to a large airport, we can find many examples of the aerospace manufacturing industry's products. For one thing, the large airport will have two or more runways which may be as long as 12,000 feet, so many more runway and taxiway lights and lighted directional signs are needed.

At the ends of the longer runways there are special lighting systems to help pilots land their airplanes properly. These lights may extend far beyond the runway's end, out into the "countryside," really. As the pilot approaches the runway he will see a certain light color if he is approaching properly, and a different color if he is not. There are many different types of such lighting systems, all of which are produced by the aerospace manufacturing industry.

As the sizes and numbers of the larger transport aircraft grow, the aerospace manufacturing industry's challenge increases. In present-day passenger/cargo terminals we can find many new products that have had to be developed just to keep up with the progress of air transportation. Closed television circuits carry the arrival and departure times of passenger flights. Special conveyer systems have been built to deliver luggage to and from airplanes. Air-conditioned bus-type vehicles may be used to take passengers from the terminal to the aircraft they will board, or there may be long telescoping, air-conditioned gangways that serve the same purpose.

The industry provides unique containers for in-flight meals. Such containers have to be constructed so that they are small and light-weight enough to be loaded onto and carried in the airplane's galley. At the same time they must keep the food cold or warm from the time it leaves the kitchen until it is served. This one activity also requires special trucks to transport the food containers on the ground.

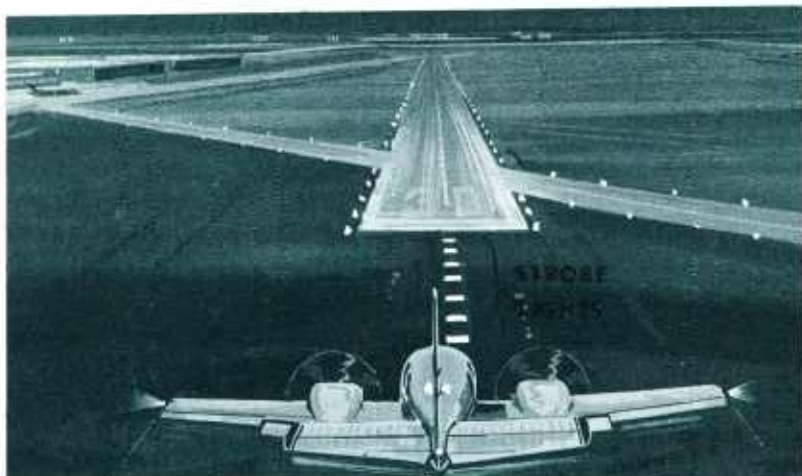

FIGURE 123

Communications and safety are of utmost importance to everyone who works at an airport. This is especially true with people who service airplanes on the ground before departures or after arrivals. If you notice the people who are driving the fuel trucks that replenish an airplane's fuel supply, you will see that the driver has a two-way radio with which he reports his actions and from which he receives instructions. The same type of communicative system is used by other personnel who unload or offload cargo, or perform any other of the many actions that have to be taken as an airplane is prepared for its next flight.

If a person has infrequent encounters with jet engine noise, his hearing will not be affected, but if he stays near such noise over a long period of time he can become deaf. This is why workers that you see around a jet airplane will always be wearing special "ear muffs" that bring the noise level down to safe limits.

The control tower at an airport is the communications hub for all activity that takes place on the ground (outside the various buildings) and in the air near the airport. The tower houses specially built electronic communications/control equipment. Controllers use radio transceivers to issue instructions to the people who operate the ground service vehicles and to communicate with pilots as they taxi to take off or approach to land. Here too will be found special radar apparatuses which monitor and show on a radarscope all activity that is taking place on the ground. One man can monitor this scope and issue appro-

priate instructions to keep the trucks and other vehicles well clear of taxiing airplanes—insuring that movement about the airport's ramp and taxi areas will be safe for everyone.

Somewhere on the large airport, or very near to it, will be radar antennae of various sizes. Of course there will be an antenna for the radarscope that monitors the ramp/taxiway traffic, but there will be several others, too. These antennae feed information into a building which houses what is known as *approach control*. The radar room in approach control contains several radarscopes. By monitoring the positions of airplanes, that appear on these scopes as “blips” or dots of light, approach control personnel can guide incoming aircraft to the airport and keep them at safe distances from each other.

One other type of radar that is of particular benefit to pilots when the weather and visibility are bad is precision approach radar (PAR). The controller who monitors PAR can tell the pilot of an approaching airplane exactly what to do to keep the airplane on a perfect path to the runway. There are two radarscopes used with this system. One shows whether the airplane is to the right or left side of a line that leads direct to the runway, and the other shows whether the airplane is too high or too low. So, all the controller has to do is tell the pilot

FIGURE 124 Control tower



when the airplane is high, low, right, left, or on glide slope—when everything is perfect.

You should understand that we have not discussed all the items that the aerospace manufacturing industry produces for use on or near the airport. Too, as each day passes, new items or improved items are manufactured. All of the manufacturers are very much involved with research, through which they discover ways of improving their products and/or their manufacturing processes, and this research brings forth entirely new products.

### AIDS TO NAVIGATION

Remember the airways we discussed in Chapter 3 and our comparison of them to “squared” tunnels? The aerospace manufacturing industry provides the instruments that mark these airways so that pilots can tell when they are following them properly.

On the ground, the primary aid is the VOR station, usually referred to as an “Omni.” This is a very special broadcasting station which transmits 360 slightly different signals. Each of these signals corresponds to one of the 360 degrees of the magnetic compass. In the airplane there is a special receiver which picks up these signals when it is tuned to the proper frequency. The receiver shows which of the 360 radials the airplane is on and whether it is traveling to or from the station. These stations, placed along the airways, give pilots a very accurate means of determining when they are on an airway and their exact location on it.

FIGURE 125 VOR radials

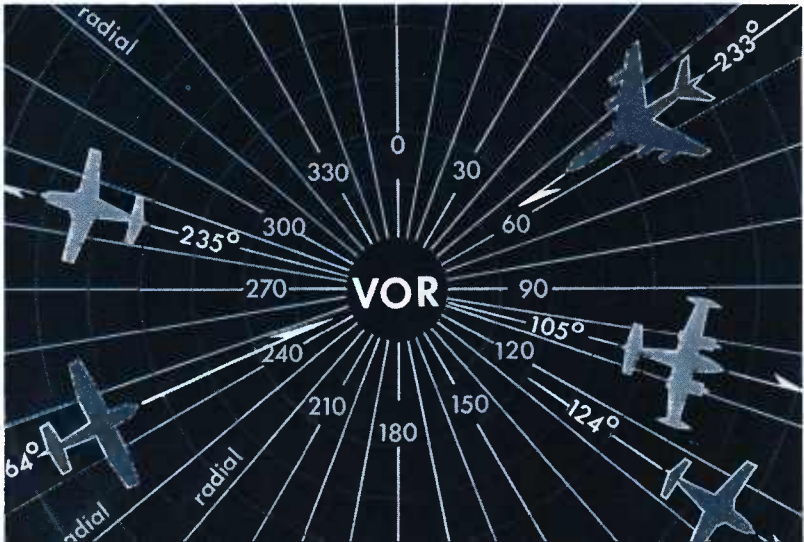

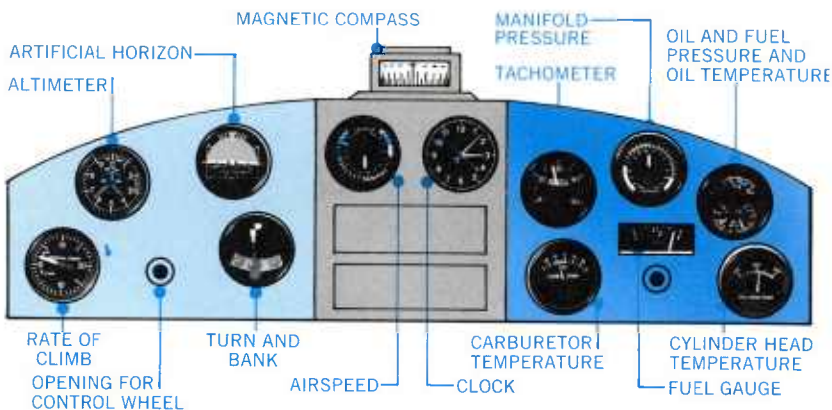

FIGURE 126 The instrument panel, with flight instruments grouped on the left, navigation instruments in the center, and engine instruments on the right.

Radar plays a most important part in the navigation aids system too. At strategic locations across the nation there are large radar antennae which feed information to enroute control centers. Again, the aerospace manufacturing industry supplies the equipment for this system. Whereas the approach control system keeps up with aircraft traffic approaching an airport, the enroute system keeps up with aircraft that are traveling between airports. This doesn't mean all airplanes are thus monitored, just those which are flying on *instrument flight plans*, and this type of flight is most often made when visibility or weather conditions are such that pilots can't see the ground—or anything else—and have to fly by reference to their instruments alone. Controllers radio pilots on such flight plans where they are in relation to points on the ground, tell them the safest altitude to fly, and tell them if other airplanes are near by.

### AIDS TO PILOTS

It has been pointed out already that manufacturers of airplanes buy from other sources much of the equipment that is placed in the airplane. This equipment also is produced by the aerospace manufacturing industry. Although you will receive detailed exposure to instruments that aid pilots when you study "Aircraft in Flight," "Power for Aircraft," and "Navigation and the Weather" we will introduce them to you now:

The *airspeed indicator* shows how fast the airplane is going through the air. It does not show how fast the airplane is flying over the ground.



FIGURE 127 THE AIRSPEED INDICATOR



FIGURE 128 THE ALTIMETER

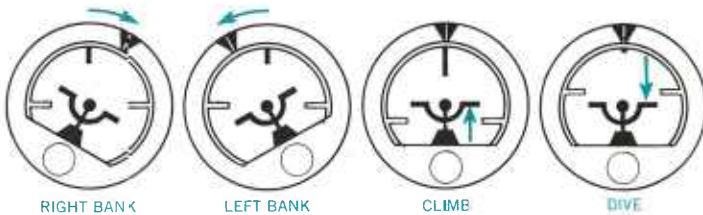

FIGURE 129 THE GYRO HORIZON

The *altimeter* shows how high the airplane is above sea level in feet. To find out how high he is above the ground, the pilot simply subtracts the known elevation of ground he is flying over from the elevation shown on the altimeter.

The *attitude indicator* is a gyroscopic instrument which shows pictorially the airplane's attitude in relation to the horizon. From this instrument the pilot can tell whether he is climbing, descending and/or turning.

A *clock* usually is a standard instrument on all aircraft. This allows the pilot to calculate his speed over the ground, the time it will be when he arrives at the next airport, etc.

The *heading indicator* is another gyroscopic instrument. It shows, after being set properly, which direction the airplane is going—in relation to magnetic north. In effect, this is a compass.

Every airplane has a *magnetic compass*, and its use is obvious. Unless an airplane is flying straight and level, the magnetic compass isn't much use to a pilot. This is because it swings erratically when the airplane isn't flying straight and level. Yet, the magnetic compass is the pilot's final authority on the direction of magnetic north, and it is the reference instrument he uses to set his heading indicator properly.



FIGURE 130  
HEADING INDICATOR  
AND MAGNETIC COMPASS

*Radar* is one item that relatively few airplanes have on board, but the aerospace manufacturing industry does provide airborne radar systems so we'll mention them. One type has a radarscope and antenna to show what is ahead and below. With this type of system, pilots can avoid severe weather and can detect the presence of other aircraft before they are visible to the human eye. Another radar system sends a signal direct to the ground and measures the actual height the airplane is above the surface.

*Radio* equipment especially made for installation in airplanes has become a requirement for all flights to the larger or busy small airports. This is a sensible requirement because, who would want to fly into a "behive" of airplane activity without being able to communicate with anyone?

A *rate of climb* indicator tells pilots how fast they are climbing or descending. Thus, if a pilot wants to descend 1,000 ft. in two minutes, he would adjust his descent until the rate of climb indicator shows 500 feet per minute.

The *thermometer* is a most important instrument. By properly interpreting what the outside air temperature thermometer tells him, the pilot can avoid inconveniences such as an iced-up carburetor and a stopped engine.

FIGURE 132  
THE TACHOMETER

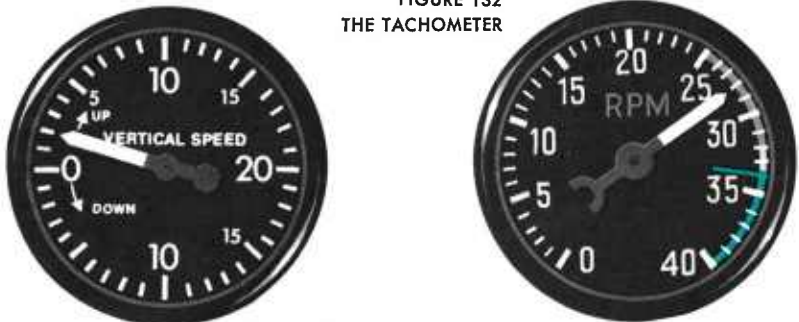

FIGURE 131  
RATE-OF-CLIMB  
INDICATOR



FIGURE 133 THE TURN-AND-BANK INDICATOR, FORMERLY REFERRED TO AS "NEEDLE & BALL"; OPERATES LIKE A CARPENTER'S LEVEL: WHEN BALL IS IN THE CENTER, PILOT IS EITHER FLYING STRAIGHT AND LEVEL OR MAKING A WELL CO-ORDINATED TURN: NEEDLE TELLS HIM WHICH: IF AIRCRAFT IS TURNING TO RIGHT OR LEFT, NEEDLE MOVES TO THE RIGHT OR LEFT.

The *tachometer* shows how fast the engine's crankshaft is turning in revolutions per minute. Pilots use this information in several ways, one being to adjust the engine to the power setting needed for certain landing configurations.

The *turn and bank indicator* is a fairly simple standard device. Up to a certain point, it will show the pilot how long it will take him to make a turn, in minutes, according to the bank he has established. Also it will tell him that if his airplane is not slipping toward the inside of the turn or skidding toward the outside, his turn is coordinated.

The *VOR receiver*, as mentioned earlier, shows along which of the 360 radials, broadcast by the VOR ground station, the airplane is flying. After the pilot selects the proper radial, this instrument will show him which direction he should fly (right or left) to keep his aircraft on the radial.

Finally, there are several other instruments that give pilots needed information. Included are fuel gauges, alternator output gauge, cylinder head temperature gauge, oil pressure and temperature gauges, and carburetor temperature gauge. Again, you will learn more about such instruments in "Power for Aircraft" and "Aircraft in Flight."

## LAUNCH SYSTEMS

The aerospace manufacturing industry provides "tools" for launching the missiles and spacecraft it builds.

No doubt everyone is familiar with the term *launch pad* because of the extensive exposure, via television, to Cape Kennedy and the spectacular launchings of Apollo spacecraft and others. Yet, it is probable that not many people consider how much knowledge and work it took to build just the launch system for such giant craft. Actually, it takes as much effort and skill to perfect the more complex launch systems as is required to build the craft. Let's examine, rather superficially, the launch system for Apollo spacecraft.

After considering several approaches to the best methods for putting together sections of the huge Saturn booster and topping them with the Apollo spacecraft, it was decided to build a vehicle assembly building (VAB). What resulted was a mammoth structure which measures 525 feet in height, 716.5 feet in length and 518 feet in width. It has more interior space than any building in the world.

The VAB's electrical systems, hydraulic systems, pipes for water and other fluids, and communications systems—to name a few—dwarf similar systems elsewhere. The industry provided special cranes that lift and place the huge sections of the booster rocket/spacecraft one on top of the other. Also, special adjustable work platforms had to be designed and built to allow technicians to work at all levels of the Saturn/Apollo.

The industry's unique capabilities produced a mobile launcher, a transporter, a mobile service structure, the actual launch pad, and a launch control center. The transporter's first job is to transport the mobile launcher into the VAB. The booster/spacecraft rests on the launcher as it is assembled and tested for proper function of systems.

When all systems are checked, the transporter reenters the VAB to move the enormous weight of the mobile launcher, with its Saturn/Apollo space vehicle cargo to the launch pad. Leaving the moon vehicle assembly on the pad, the transporter then brings the mobile service structure to the launch pad where it services the Apollo spacecraft atop the booster rocket. The transporter's last job in this prelaunch sequence is to remove the service structure just before liftoff.

The control center, developed and constructed within a very few years by the aerospace manufacturing industry, is positioned near the VAB. It contains so many complex devices that several volumes would be required to explain them. There are many computers, television screens, telephone and radio communication systems, etc. with which launch control personnel monitor every aspect of the vehicle's readiness to fly before they make the final decision that the craft is indeed ready for lift-off.

The aerospace manufacturing industry of course provides launch systems for smaller rockets. For instance, there are sites where silos, deep in the ground, house and protect our defensive intercontinental ballistic missiles. These silos have to serve as the missiles' home in case they ever have to be launched. The silo, then, is the "launch pad" for this type of rocket. It must contain everything needed to keep the rocket missile in launch readiness up to and including a possible actual

launch. This again means that all sorts of special devices must be available in addition to intricate electrical and electronics systems.

Similarly, the industry provides submarine launch systems for the Polaris and Poseidon types of underwater-launched ballistic missiles. Many other types of launch systems have to be created for the rocket missiles that are fired from aircraft and from the ground.

## GUIDANCE SYSTEMS

During our discussion of “aids to navigation” and “aids to pilots” the devices mentioned could be considered parts of a guidance system. After all, they do contribute to keeping an airplane on the desired course at the desired speed so that it will arrive at its destination at the desired time. The real guidance system, however, in the great majority of airplane flights is the pilot. The pilot gets needed information from controller personnel, who are following him by radar, and from the navigation instruments in his airplane. The pilot then decides whether to speed up or slow down, whether to turn right or left, whether to ascend or descend. When vehicles are involved that either do not have a pilot on board or travel at such speeds that human guidance actions might prove inaccurate, the aerospace industry provides a guidance system.

Already there exist for airplanes various types of guidance systems of a sort. These are the “automatic pilots,” but the automatic pilots do little more than keep the airplane at the height, speed and direction that the human pilot has decided to be correct. For the new generation of supersonic transport (SST) aircraft, which approach speeds of 2000+ miles per hour, the industry will provide fully automated guidance systems which will guide the SSTs through any or all of their flight phases.

Guidance systems for spacecraft and missiles are produced in a variety of forms. Inertial guidance systems are required for some types of military missiles and for scientific rockets. The inertial guidance system is mainly self-contained, and uses a computer which has programmed into it the exact path the vehicle should fly. Devices known as accelerometers and gyroscopes sense every movement the vehicle takes, and, in effect, tell the computer what is happening. If there is a deviation from the computer’s program, the computer will send steering commands to the on-board flight controls so that the vehicle will resume the prescribed course. (See “The Dawning Space Age” text).

FIGURE 134

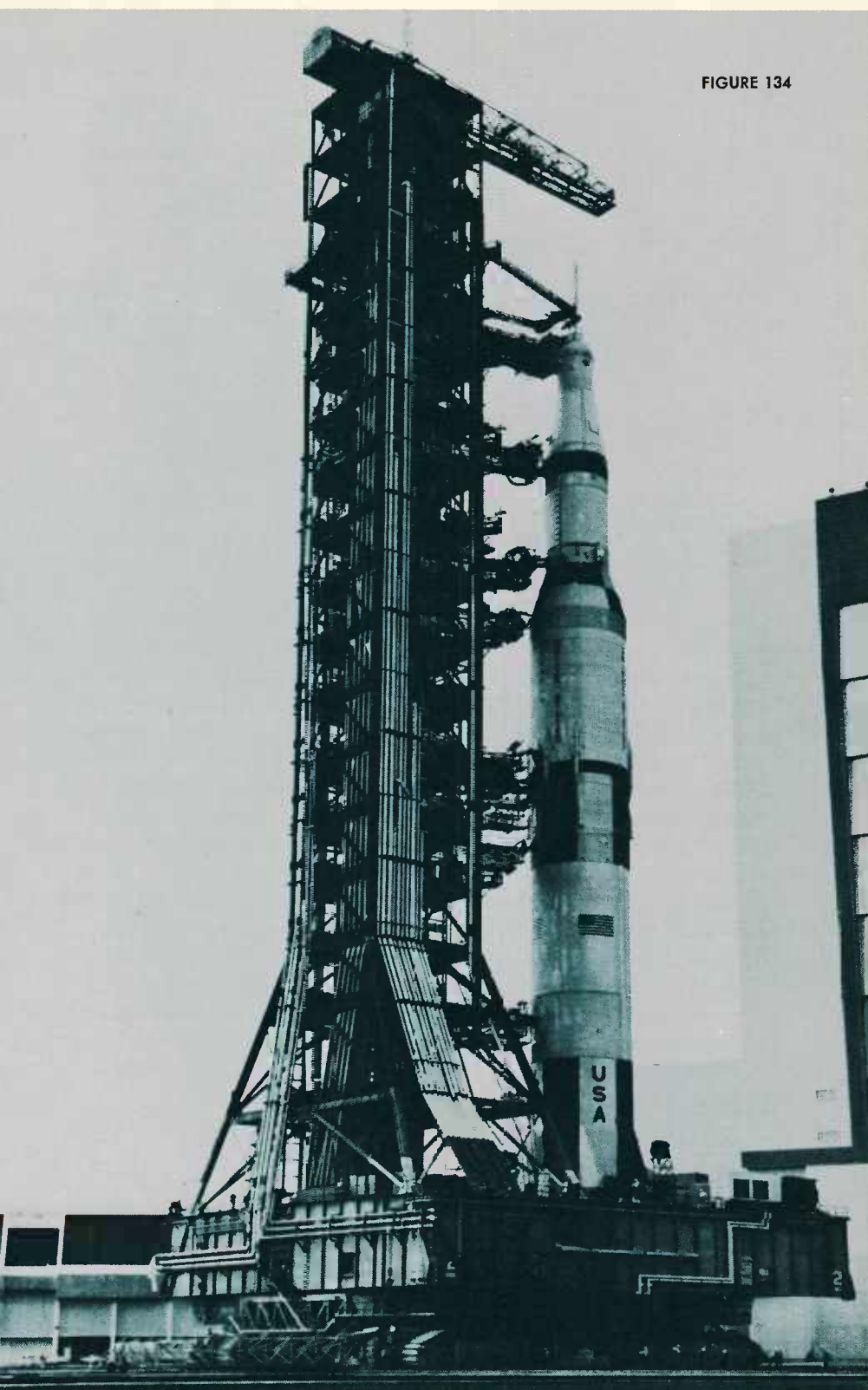

Another type of guidance system uses elaborate ground-based equipment. This is the radio command system—a combination of radar, radio, and a computer to keep up with the vehicle's flight path. Commands to change course are radioed to the vehicle's flight controls.

The industry makes other types of guidance systems for smaller rocket vehicles. One of these is the wire command system whose signals are transmitted to a rocket's flight controls via a thin wire that uncoils or unrolls as the rocket's flight progresses. Another type uses television. A television camera situated in the rocket transmits to the human controller a picture of where the rocket is along its flight path. Any needed changes are radioed to the rocket's flight controls.

According to the need, any combination of the several types of guidance systems might be placed in a single vehicle.

## TRACKING SYSTEMS

Using radar, radio, telescopes, computers, and telemetry, the aerospace manufacturing industry has provided the components for world-wide tracking systems that are essential to our nation's space program. While guidance systems direct the flight of rockets and spacecraft, it is the tracking systems that tell where such vehicles are at a specific time.

Special tracking systems monitor the progress of vehicles going to the moon and to other planets in our solar system. Nearer earth, other types of tracking systems keep up with the number, and paths, of earth-orbiting satellites.

Some tracking systems have special military applications because we must be able to detect and follow the courses of missiles, spacecraft, and aircraft launched by possibly hostile nations. Tracking systems therefore are essential to our defensive anti-aircraft missiles and anti-missile missiles. The positions and flight paths of any future incoming hostile vehicles would have to be known, and the data would have to be fed immediately to our intercept missiles. The only way to obtain such data is through "speed of light" tracking systems.

# CHAPTER 7



FIGURE 135

FEDERAL GOVERNMENT CONTROLS  
AND SERVICES

As any type of activity grows, becomes more and more complex, and eventually involves large numbers of people, it requires some type of regulation. Without regulations or laws, there would be an eventual breakdown which could prove to be dangerous to the people directly involved. This is especially true with our present day aerospace activities.

You can imagine the utter confusion that would exist and the accidents that would happen if there were no laws and regulations to govern arriving and departing flights at a large metropolitan airport. The giant jet airplanes and the small privately owned airplanes, by the hundreds, would converge on the airport, each trying to land as soon as possible. The net result would be disastrous midair collisions, as well as accidents that would occur while the airplanes were taxiing unsupervised on the ground. It wouldn't be too long before most people would decide that airplanes and like activities were not for them. Consequently, only a few brave souls would dare take to the air, and there would be no large transports and very few general aviation aircraft. Without them the nation's economy would suffer greatly. Fortunately, such is not the case because we do have a very effective system of controls, and the responsibility for the system rests with our Federal Government. But why the Federal Government? Very simply, it is logical that the Federal Government would establish uniform controls for a nationwide system. In fact, the Constitution of the United States empowers Congress to regulate interstate commerce.

Congress has delegated to several Federal Government agencies the responsibility for overseeing or providing services to various aerospace activities. These agencies include the Civil Aeronautics Board, the Federal Aviation Administration, the National Transportation Safety Board, and several others which we will discuss in this chapter.

### THE CIVIL AERONAUTICS BOARD (CAB)

An independent agency established under the Civil Aviation Act of 1938 and continued by the Federal Aviation Act of 1958, the CAB has broad responsibility for encouraging and developing civil aviation. It has economic regulatory powers over civil aviation within the United States and between this country and foreign countries.

Its regulatory powers include issuing permits to air carriers to engage in interstate and foreign air transportation, issuing permits to foreign air carriers, approving or disapproving tariffs and fares proposed

by air carriers, setting air mail rates, and subsidizing certain air carriers whose services are not self-sustaining but are required by the public.

The CAB seeks to maintain healthy competition by passing upon mergers, agreements, acquisitions of control, and interlocking relationships involving air carriers. It also has jurisdiction over unfair competitive practices.

The CAB's decisions involving domestic matters are not subject to review by any executive department or agency, but its orders may be appealed through the courts. Decisions granting or affecting certificates to domestic carriers to operate overseas, as well as permits to foreign air carriers to operate in this country, require Presidential approval.

## THE FEDERAL AVIATION ADMINISTRATION (FAA)

The FAA is organizationally a part of the Department of Transportation. It has a wide variety of regulatory and service responsibilities that concern almost the entire spectrum of aviation activities within the United States. Let us take a few lines to quote the FAA's mission:

“. . . charged with: regulating air commerce to promote its safety and development; achieving the efficient use of the navigable airspace of the United States; promoting, encouraging, and developing civil aviation; developing and operating a common system of air traffic control and air navigation for both civilian and military aircraft; and promoting the development of a national system of airports.”

To carry out this broad mission, the FAA employs hundreds of people who represent many specialties. To span the reaches of the U. S., it stations its employees at various locations throughout the land. Beginning with a headquarters which is located in Washington, D.C., the FAA is decentralized into nine regional offices. The regional offices have subunits called area offices. Together, the area offices in each region direct the activities of the region's field units.

*Safety Regulation* is one of the FAA's primary functions. To do this, the FAA conducts a phenomenal amount of research, and publishes rules and regulations that apply to all aviation activities. If you will recall from our discussion of how an airplane is built, we mentioned that the FAA inspects each airplane, and certifies, after due inspection, that the airplane was built properly and is safe to fly. After the manufacture of each airplane, the FAA keeps up a safety vigilance

by requiring that the airplane receive a periodic inspection of its structure and engine. Such inspections have to be recorded in specified log books that remain with the airplane until it no longer is in flight service. The specialists who do the inspecting and necessary repair work on airplanes are not necessarily FAA employees, but they are examined by the FAA and certificated to do such work.

Still within the realm of safety operations are the prescribed course curricula that mechanics, pilots, and other aviation specialists must study at FAA-recognized schools. There must be standardization of such courses and examinations to insure the competence of the people who repair and fly the airplanes. The physical condition of pilots is also an important safety factor, so FAA regulations require that all pilots receive a periodic physical examination by a physician designated by FAA. If a pilot is a private pilot, he must pass a physical examination every two years; if he is a commercial pilot (can carry passengers for hire) the examination is required annually; and if the pilot is working for an airline (air carrier), he must pass the physical examination every six months.

Everyone who aspires to become a pilot has to do quite a bit of study and spend many hours in actual flight training. But first of all the FAA decides the age at which flight training can begin. Currently, you can begin glider flight training at 14 years of age, and powered flight training at age 16. Yet, a young trainee cannot be certificated as a private pilot unless he is 16, for gliders, or 17, for powered airplanes. Upon completion of a person's studies he is given an FAA written examination to see if his knowledge of various subjects is adequate for safety purposes. When his actual flight training phase is over, the FAA requires him to take a practical examination which involves an FAA flight examiner, or designated flight examiner, flying with the candidate to see if he can fly the airplane safely and recover from unexpected flight situations without endangering himself or others.

The Federal Aviation Administration has the authority to enforce its rules. In the event a pilot is discovered conducting a flight that violates one of the many regulations, the FAA can suspend the pilot's certificate temporarily or permanently, depending on the magnitude of the violation.

*Registration and Recordation* of all non-military aircraft operating in the U. S. is another task performed by the FAA. This includes not only an up-to-date record of the owner, but it also includes the air-



FIGURE 136

craft's nationality, engines, propellers and appliances—special equipment.

*Air Navigation Facilities* are a service performed by the FAA although such facilities are actually not required for efficient navigation under VFR conditions. Long before navigation facilities were available, pilots could find their way across the continent by flying VFR from point to point, but they now can navigate safely and quickly over long distances to almost any point in the nation without relying on guesswork and luck. The FAA is responsible for planning, locating, maintaining, and testing the electronic air navigation facilities that make safe air travel possible under all types of weather conditions. FAA pilots and electronics technicians are required to fly and use the facilities to test their proper function and accuracy. When a malfunction is discovered, electronics technicians go to the affected facilities and make necessary repairs. The major type of air navigation facility that FAA establishes and maintains is the VOR ground transmitter. (This device, which was mentioned earlier, allows pilots to tune their VOR receivers and fly direct to the various stations along their routes.) Other types include visual reference devices and radar surveillance equipment located at airports and enroute control centers. Tying together the various air navigation facilities and offices is an extensive network of communications equipment which includes radios and teletype machines.

*Airspace and Air Traffic Management* is now an essential function for the smooth and safe flow of flights across the nation and to points in between. The FAA develops and publishes air traffic rules and regulations, and it decides how the airspace will be used. It designates the dimensions and locations of airways between airports and the airspace around airports. To manage the air traffic and enforce the many rules and regulations, the FAA operates a network of airport control towers, air route traffic control centers, and flight service stations. FAA personnel in the airport control towers manage traffic that wishes to land or to take off. Controller personnel located in the air route traffic control centers manage many of the flights that take place between airports and over long distances. Management of air traffic is a vital service to pilots because they are helped in their efforts to keep at safe distances from each other. Also the controller/managers can help them in several ways if they have trouble with their flights.

More in the strict sense of service is the assistance provided to pilots by flight service stations (FSS) personnel. These "stations" are located at airports where pilots can go in and get many different types of information that will aid them in the completion of safe flights. Before a pilot begins his flight, the FSS personnel will brief him on weather conditions that he can expect along the route, and they will alert him to any special precautions that should be taken when landing at en-route airports or the destination airport. Although a flight plan is not required, all pilots should file one with FSS personnel. Most pilots do this because the flight plan allows the FAA to monitor the progress of the flight and to notify search and rescue units if the flight isn't completed when expected. As you can readily see, it is much easier to find a missing airplane when its planned route is known.

*Research and Development* are basic to aerospace progress, and the FAA conducts an extensive R & D program at its facility in New Jersey. Here, the agency works toward developing and testing improved aircraft, engines, propellers, and instruments used in aircraft. At the same time it tests new or improved versions of navigational aids, and new approaches to air traffic control procedures. All such efforts have the dual purpose of developing safer and more efficient air transportation.

The *Education and Training* requirement is another element within FAA's responsibility. Its personnel devise and have published training and informational texts that are available to the public. It conducts an extensive training program for new FAA personnel at the

Aeronautical Center in Oklahoma City, Oklahoma. All new employees who eventually will work as air traffic controllers, flight service technicians, etc., attend courses of varying lengths before being assigned to a work station.

*Airport Development* and specifications for airport facilities require much of the FAA's effort. The types of airports available to the flying public vary greatly, as we have stated earlier. This is because they are constructed to serve the particular needs of a community. FAA personnel help and encourage communities to build airports in several ways. One way is to survey and advise on the location and size of the contemplated airport. FAA's advice includes recommendations as to the length, width, and direction of runways; the support facilities that will best serve arriving and departing air traffic, such as lighting systems, repair facilities, control tower, and so forth. Perhaps of greatest interest to the community that wants an airport, or to a community that wants to improve its airport, is the Federal monetary assistance that FAA administers. In brief, this program provides matching funds for airport construction or improvement, so the community needs only to raise about ½ the money required to complete an airport project.

This has been only a brief overview of the FAA's extensive role in the promotion of and regulation of flight activities within the United States. Overall, this government agency is really more of a service organization than a regulatory agency, even though it does have the authority to take action against violators of published rules and regulations. It is the largest government unit, other than the armed forces, that is primarily concerned with flight activities, and, as the number and speed of aircraft increase, the FAA undoubtedly will have to expand. In any event we should be grateful for the existence of this type of organization for without it travel by air would be neither safe nor efficient.

### THE NATIONAL TRANSPORTATION SAFETY BOARD (NTSB)

This government agency is similar to the Civil Aeronautics Board in that it is autonomous. It is answerable only to the Congress, and accomplishes this obligation through annual reports. Included in the reports to Congress are recommendations on needed legislation which has to do with areas that are within the NTSB's realm of responsibility.



FIGURE 137

Investigation of civil aviation accidents is one of the functions of the NTSB. Now, we know that aviation activities within the United States are extensive in number and area, so it would take a very big organization to investigate every aircraft accident, and most accidents, or incidents, are minor in nature. For this reason, the NTSB works closely with the FAA and has delegated to the FAA the responsibility for investigating accidents involving small aircraft unless there is a fatality, and certain accidents in Alaska.

The NTSB is headquartered in Washington, D.C., but it does have what are called "field offices." These offices are located so that anyone having business with the board will not have too much difficulty contacting one of the field offices. Along the east coast there is an office in New York City, one in Washington, D.C., and one in Miami, Florida. For pilots who are in the central portions of the country, offices are located in Chicago, Illinois; Fort Worth, Texas; Kansas City, Missouri; and Denver, Colorado. Pacific coast regions and Alaska are covered from offices in the cities of Los Angeles and Oakland, California; Seattle, Washington; and Anchorage, Alaska.

Next to the Federal courts, the NTSB has the final say when action is taken against aircrew members who have had accidents which re-

sulted from violations of published rules and regulations. The beginning of such actions is the requirement for an operator's report (operator meaning the person who owns and/or flies the aircraft) on the nature and details of the accident. If investigation of the accident reveals a violation, then appropriate penalties are levied against the person or persons responsible. But it should be remembered that the NTSB's reason for existence is not to develop rules and mete out punishment for violation of those rules; rather, its primary purpose is to develop standards that improve safety.

### THE NATIONAL BUREAU OF STANDARDS (NBS)

Almost everyone is familiar with this Federal bureau, particularly in reference to weights and measurements. But what role can or does it play in reference to aerospace activities? Very briefly, the National Bureau of Standards is a principal Federal Government agency for assuring maximum application of the physical and engineering sciences to the advancement of technology in industry and commerce. To this end, the Bureau conducts research, and provides central national services in four broad areas. These are: (1) basic measurements and standards, (2) materials measurements and standards, (3) technological measurements and standards, and (4) transfer of technology. The NBS assures that its staff has optimum accessibility to the scientific information of the world, and seeks to facilitate technological innovation in industry and government.



FIGURE 138



FIGURE 139

The Bureau conducts an extensive amount of research that is applicable to aerospace activities, and it serves as a clearing house for research done by other organizations, both Federal Government and non-Federal Government. As a clearing house, the Bureau publishes numerous types of documents that are of interest to researchers, and many of these documents are specialized. If a researcher is working in a specialty field, such as chemistry, the Bureau has available the latest research findings on chemistry including laboratory data, experimental procedures, theoretical and mathematical analyses, etc.

Design and manufacturing engineers concerned with developing a new type of airplane or aerospace vehicle can obtain from the Bureau data on the weights and strengths of various alloys, and so forth. So the Bureau's activities definitely influence aerospace activities.

### THE NATIONAL AERONAUTICS AND SPACE COUNCIL (NASC)

The National Aeronautics and Space Council was established by the National Aeronautics and Space Act of 1958, the same Act which brought the National Aeronautics and Space Administration into being. The Council advises and assists the President regarding policies, plans, and programs; fixes the responsibilities of the agencies engaged

in aeronautical and space activities, and develops a comprehensive program for such activities.

The Council is composed of the Vice President, the Secretary of State, the Secretary of Defense, the Administrator of the National Aeronautics and Space Administration, and the Chairman of the Atomic Energy Commission. Its Executive Secretary is an astronaut.

## THE NATIONAL AERONAUTICS AND SPACE ADMINISTRATION (NASA)

Almost everyone in the world who has access to a television or movie screen, or who can read, is familiar with this agency. After all, the United States has given wide and open publicity to the world on U.S. space efforts, and NASA is always in the forefront of such coverage because it manages our space programs (those that do not involve national defense applications).

Congress created NASA in 1958 with the intent that activities in space should be devoted to peaceful purposes and for the benefit of all mankind. In other words, NASA was to be a special non-military organization that could consolidate and coordinate the Nation's efforts in aerospace research and could share the results of its research with others. Its statutory functions are to:

“1. Conduct research for the solutions of problems of flight within and outside the earth's atmosphere, and develop, construct, test, and operate aeronautical and space vehicles.

“2. Conduct activities required for the exploration of space with manned and unmanned vehicles.

“3. Arrange for the most effective utilization of the scientific and engineering resources of the United States with other nations engaged in aeronautical and space activities for peaceful purposes.

“4. Provide for the widest practicable and appropriate dissemination of information concerning NASA's activities and their results.”  
(From United States Government Organization Manual—1970/71.)

There are eleven field installations in NASA's organizational structure. These installations are spread out among eight different states.

*The Ames Research Center*, Moffet Field, California, has the mission of conducting basic and applied research in space environmental physics; gas dynamics research at extreme speeds; biomedical and biophysical research; and research concerning the configuration, stability, structures and guidance control of aeronautical and space vehicles.

The *Flight Research Center* at Edwards AFB, California, investigates various aspects of both aeronautical and space vehicles, including flight operations, flight systems, and structural characteristics.

The *Langley Research Center* at Langley Field, Virginia, conducts research which is applicable to aeronautical and space structures and materials. In addition, it investigates the aerodynamics of re-entry vehicles, the physics of space environments, life sciences, and subsonic and supersonic flight.

Cleveland, Ohio, hosts the *Lewis Research Center*. Here, the emphasis is on development of power plants and propulsion, which includes high energy propellants, nuclear rockets and electric propulsion. In addition, the center is responsible for management and procurement of "medium" launch vehicle programs.

The *Space Nuclear Propulsion Office* in Germantown, Maryland, represents the cooperative efforts of two Federal Government agencies. Here the responsibility for researching and developing nuclear rocket propulsion for space vehicles is shared by the Atomic Energy Commission (AEC) and NASA. It is therefore referred to as the Joint AEC-NASA Space Nuclear Propulsion Office.

At Huntsville, Alabama, personnel assigned to the *George C. Marshall Space Flight Center* are responsible for developing launch vehicles and systems to launch both manned and unmanned spacecraft. In other words, this is the center which develops booster systems like the Saturn. As you learned earlier during our discussion on how the Saturn is built, this is in itself a highly complicated mission. There is much scientific and engineering research involved, and there is a continuing requirement for close coordination with other NASA offices and civilian contractors.

The *Manned Spacecraft Center* in Houston, Texas, develops man-carrying spacecraft, and trains astronauts. This mission includes the development of life support systems necessary to space flight systems whether they be to the Moon, Mars, or any other location in space. Correlative research is done in medicine, engineering, and other applicable fields.

The *John F. Kennedy Space Center*, in Florida, develops and provides the launch facilities for space vehicles and support activities for accomplishing landings. It is here that the major components of launch vehicles and spacecraft (payloads) are assembled. After being checked out for proper operation of systems, they are fueled and launched. The center coordinates its developmental activities with

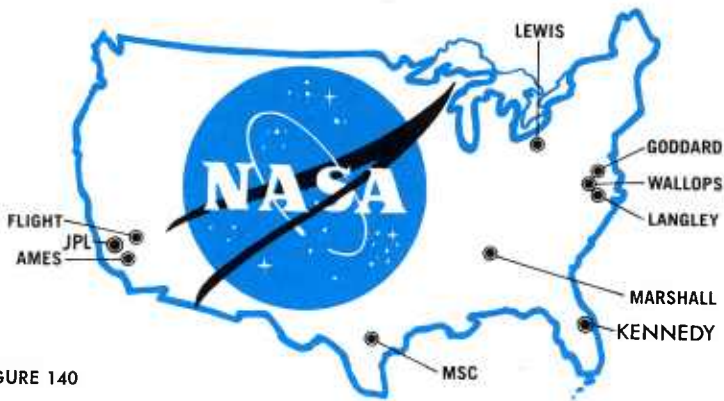

FIGURE 140

those Department of Defense offices which are responsible for launching military rockets. This coordination avoids unnecessary duplication of launch facilities.

*The Goddard Space Flight Center* is Greenbelt, Maryland, accomplishes scientific research in space with unmanned satellites. In addition, the center is charged with developing meteorological and communications satellites, and it conducts tracking and data acquisition operations.

By contract, the California Institute of Technology operates the *Jet Propulsion Laboratory*. Its research and development mission is concerned with the spacecraft, tracking, and data acquisition systems used in deep space, lunar, and interplanetary scientific explorations.

*Wallops Station*, Wallops, Virginia, is a launch site. Whereas the John F. Kennedy Space Center launches the "big birds," Wallops Station launches the much smaller vehicles. From this center, small rockets are launched to conduct either suborbital, orbital, or space probe experiments. The Scout four-stage solid fuel rocket is the largest one launched from Wallops Station. The station is not just a launch pad, so to speak, because its personnel also are responsible for developing techniques for collecting and processing experimental data.

From our brief description of the above eleven field installations you probably feel that there is an overlap in missions. In the broadest sense, this could be true. For example, several installations work with and on propulsion systems, but their efforts are toward a specific set of goals; also research results are shared between the various installations which have similar interests.

What we will point out now is that the field installations were not established at random. In fact there are three major program offices, within NASA's headquarters structure, among which are divided the responsibilities for supervising and coordinating the work of the field installations.

*The Office of Manned Space Flight* directs all of NASA's efforts that apply to manned space flight. This includes the booster systems, spacecraft, launch facilities, life support systems, and all other related systems. Therefore, this office supervises the John F. Kennedy Space Center, the Manned Spacecraft Center and the George C. Marshall Space Flight Center.

*The Office of Space Science and Applications* has the responsibility for scientific explorations of space, the moon and the planets. In addition, it must determine the peaceful applications of space systems technology to other fields such as communications and meteorology. Therefore, this office supervises the activities of the Goddard Space Flight Center, the Jet Propulsion Laboratory, and the Wallops Station.

Coordinating NASA's total research and development program to assure adequacy and to eliminate unnecessary duplication of effort is the *Office of Advanced Research and Technology*. All the research centers report to this office. If you will recall, these include the Ames

FIGURE 141



Research Center, the Langley and Lewis research centers, and the Flight Research Center. In addition, the Joint AEC-NASA Space Nuclear Propulsion Office is a part of this organizational structure.

Finally, there is the *Office of Tracking and Data Acquisition*. You will note that this fourth office does not supervise any field installations. Yet its activities are rather spread out because the office is responsible for developing, providing, and operating all the facilities needed to track and gather data from the vehicles launched by NASA. Also, the office manages NASA's long-line (telephone) communications system.

Thus far in our discussion, it should have become obvious to you that Federal Government controls and services are complicated, and involve many people—people whom we the public never see on television or read about in newspapers. But without these people and their skills, we would not have an effective air transportation system, and we would not have a space program. We would be at a standstill in growth and development throughout many fields of human endeavor. These people help provide the necessary coordination, controls, and services to keep the systems going—on the civilian side.

## THE FEDERAL COMMUNICATIONS COMMISSION (FCC)

This Federal agency controls all aspects of aerospace radio communications in one way or another. For one thing, it assigns the radio frequencies which will be used for various types of aerospace communications. It establishes the requirements for a person to be permitted to operate a radio; it licenses all radio stations, and this includes those that are placed in airplanes; and it establishes the phraseology that is standard for spoken radio communications.

Of the several subdivisions in the FCC organization structure, the Safety and Special Radio Services Bureau and the Field Engineering Bureau affect aerospace activities the most. The first bureau licenses and regulates radio stations not in the broadcasting or common carrier categories; this includes radio "stations," or transceivers, that are placed in airplanes. The Field Engineering Bureau, through its field offices and stations, monitors radio transmissions to see that transmissions are conducted according to established rules; also this monitoring function includes tests to see that broadcasts are within the frequency authorized, because mechanical problems can cause transmissions to occur on the wrong frequencies.

The field offices and stations are the point of contact for people who want to be “licensed” to use a radio transmitter. For the majority of pilots, all that is required is a restricted radiotelephone operator permit. This allows them to talk to FAA controllers and others with whom they have business.

## THE NATIONAL OCEANIC AND ATMOSPHERIC ADMINISTRATION (NOAA)

NOAA is part of the Department of Commerce. Within this agency’s National Oceanic Survey are produced the various types of aeronautical charts that pilots use. We will not discuss these various types of charts because the CAP text “Navigation and the Weather” provides detailed coverage of them. Suffice it to say that the charts are of such variety that pilots have a choice according to the type of navigation that they want to use, and the distance and altitude that they will fly.

### THE NATIONAL WEATHER SERVICE

Also a part of this administration is the National Weather Service. For years this was known as the Weather Bureau, and then a reorganization brought about the change in name. Anyway, the National Weather Service has the task of providing to pilots and everyone the status of weather conditions nationwide. This is difficult enough, but the meteorologists also must predict what weather conditions will be in hours and days to come.

Meteorologists use data that come from many types of sources. Available to them is information provided by weather satellites, ships at sea and observatories positioned at certain points throughout the land. From the input of data provided by these sources, the service prepares different types of charts which show such things as the amount of cloud cover over the country and its exact location, wind directions, amount of precipitation and so forth. In addition to the charts, teletype machines pound out what are known as weather sequence reports. These reports are written in a special code which shows the type of weather existing at reporting stations at any given hour of the day.

Without the information provided by the National Weather Service, pilots, in particular, would find themselves in dangerous situations because they would not know what types of weather conditions they were flying into.

## THE DEPARTMENT OF DEFENSE (DOD)

Aerospace operations in the Department of Defense are not unlike those conducted and controlled by other Federal Government agencies. The United States Air Force has the largest role to play, in the strict sense of aerospace activities, but the U.S. Army is assigned certain aerospace missions, and so are the Navy, the Marines, and the Coast Guard. Each of the services uses airplanes and rockets, but the differences lie in the number, ranges and purposes of such vehicles.

As was pointed out earlier, the Federal Aviation Administration is the prime *controlling* agency for aviation operations within the United States; the National Aeronautics and Space Administration "unites" the program for space missions; the Civil Aeronautics Board establishes air carrier routes and approves fares; and the National Transportation Safety Board investigates or has investigated civil aviation aircraft accidents. DOD aerospace operations are conducted a little differently.

While operating within the airspace controlled by the FAA, military (DOD) flight operations must be conducted according to the rules established for all flights. Yet, each military base has its own controllers who issue instructions to military pilots, and control the airplane traffic that arrives at and departs from the base. In many instances, the military controllers and FAA controllers are co-located because civilian and military airplanes use the same airport facility.

Briefly, the military services duplicate within their organizations the controls and services that are provided to civil aviation by the Federal Aviation Administration, the National Transportation and Safety Board, the National Weather Service, and National Oceanic and Atmospheric Administration. One might question the reason for such duplication since other Federal agencies could and do provide the same types of controls and services. This would be a valid argument if the military's aerospace operations always were conducted only within the United States or its possessions. But they are not, so the military units must take with them a system of controls and services wherever they go.

Military air traffic controllers are trained to govern flights in both peacetime and wartime environments, and their duties in the peacetime environment must nearly duplicate those of FAA controllers. The military controllers use the same types of equipment as the FAA, and their procedures, for all practical purposes, are the same. Perhaps the

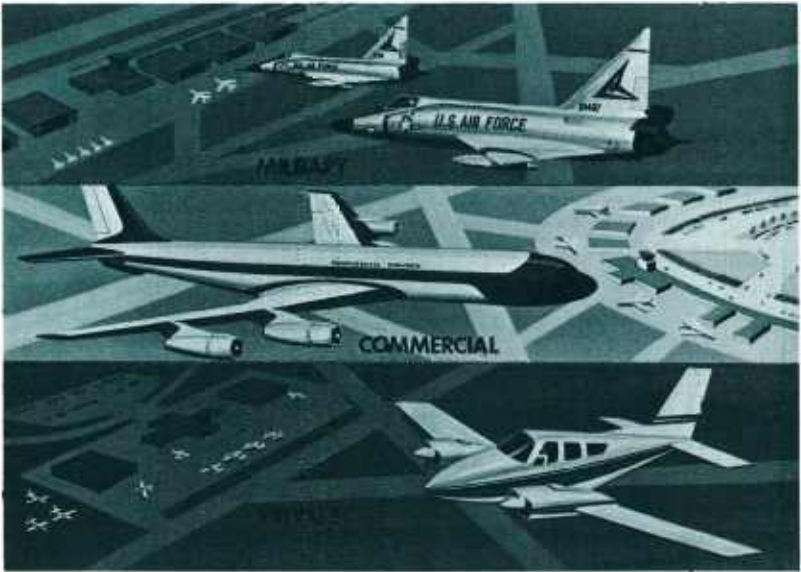

FIGURE 142

greatest differences between the two lie in Marine Corps and Navy aircraft carrier operations which occur at sea on speeding, rolling ships and require unique operational procedures.

Whereas the Coast and Geodetic Survey of the Department of Commerce provides aeronautical charts (maps for air navigation) to the civil aviation community, the U.S. Air Force's Aeronautical Chart and Information Center (ACIC) at St. Louis, Missouri, does the same for the military services. (The ACIC also creates charts for space flights, including charts of the moon.) These charts are similar in some ways to the civilian types because the depiction of topographic features on aeronautical charts is standardized. Too, the scales used on the charts will be similar. The principal differences between the civilian and military types of charts are the amounts and kinds of information shown on them; in other words, the details.

The military services have their own meteorologists who provide up-to-date weather information and forecasts for pilots and others. Again these specialists use the same types of meteorological equipment as their counterparts who work for the National Weather Service.

Safety is a concern of the military services too, so they conduct their own safety programs. This isn't to say that there is no cooperation on

safety matters between the military services, FAA, and the NTSB, because there is. Yet, when a military airplane is involved in an accident that does not include a civilian airplane, the FAA and the National Transportation and Safety Board have no investigative authority. The investigation is conducted by military personnel, and if there is need to take action against any of the personnel involved, it is the military service involved which takes the action.

In regard to high speed aircraft, missile, and space operations, certain areas and points within and outside the United States are designated as test ranges and launch facilities. On aeronautical charts these are clearly outlined, and access by air into them may be prohibited entirely or restricted. If it is restricted only, a pilot may gain permission to fly through it from the military commander who has control of the particular area. This type of control is not established arbitrarily; it is for the safety of all concerned and, in some cases, for national security purposes.

Military space operations are conducted from special sites. Such operations involve unmanned satellites that provide information on the activities of non-friendly nations. Information thus gathered helps our military forces to evaluate the strength of a potential or actual enemy. Also, satellites in this category can give us instantaneous warning of any future attack on the United States, thereby allowing our military forces time enough to mount a retaliatory attack against the aggressor.

Where space operations are concerned, the National Aeronautics and Space Administration cooperates with the United States Air Force and the U. S. Navy. For example, NASA uses Air Force and Navy personnel in launch and recovery operations of manned space flights, such as Apollo; and the Air Force uses NASA facilities for its space launchings.

## COORDINATION OF AIR AND SPACE ACTIVITIES

As we have discussed in preceding passages, there certainly is a need for the rules, regulations, laws, etc. that control air and space activities, and Federal agencies are the only ones that can do the job on a national basis. What we want to emphasize now is the coordination and cooperation that must go on between all parties associated with aerospace activities.

We have called your attention to the coordination and cooperation among Federal agencies. Recall that FAA and military personnel

sometimes are co-located and together control air operations. Also, NASA, the Navy, and the Air Force lend each other support. But what about the Federal/civilian relationship?

Civil aviation employs many more aircraft and conducts more flights in the United States than all Federal and other governmental departments put together. Too, civil aviation represents hundreds of thousands of private pilots and businessmen who are voters. In our type of government, voters have much to say about controls. Therefore, when one of the Federal agencies, like the FAA, decides that a rule or law should be made or changed—whatever the purpose—the civil aviation community has a chance to coordinate on the proposal, if the civil aviation community will be affected. Such coordination is normally in the form of a hearing where all sides get a chance to present their arguments, or individuals may have the opportunity to submit their ideas on the proposal in writing. Once the “hearing” is concluded, the Federal agency decides whether to publish and enforce the rule. Once this is done, everyone is expected to abide by the rule. This is not to say that the rule can’t be changed or done away with, because it can; the courts can set aside or cause to be reconsidered any rule or law if there is sufficient justification.

With the exception of letting his opinion be known, there is not much an individual private citizen in the civil aviation community can actually do about Federal rules that affect him adversely. As part of an organized group, however, he can influence changes because the combined voices of a large group speak loudly and effectively. For this reason, there are several organizations which represent various interests in the civil aviation community. Leaders of these organizations coordinate with Federal Government agency officials and work diligently to make certain that all controls imposed on civil aviation operations are needed, are fair to all concerned, and are in the best interests of aviation activities in general.

Cooperation between the Federal Government and the civilian community is of the utmost importance to the space program. For example, in 1956, the U. S. Air Force initiated Project 7969 entitled “Manned Ballistic Rocket Research System.” The stated task of this project was the recovery of a manned capsule from orbital conditions. The project had no precedent, and the best minds in eleven aerospace industries went to work to prepare proposal studies. Although the Air Force effort in manned orbital flight during the two-year period 1956–58 was a study project without an approved program leading to

the design of hardware, the effort contributed to manned space flight. The studies the Air Force sponsored on such things as the life-support system were used by the civilian companies who later submitted proposals for the Mercury spacecraft design and development program. Also during this period there was considerable interchange of information between the Air Force and the National Advisory Committee for Aeronautics, later the National Aeronautics and Space Administration (NASA).

When the various branches of the armed forces or NASA are ready to prepare study projects or to develop the actual hardware for a project, they prepare specifications which are submitted to interested civilian companies who have the capability to respond. The companies are invited to submit bids in accordance with the specifications. The bids include the estimated costs for each phase of the project, and there is usually much rivalry among bidders. The companies submit their sealed proposals to the agency, and, on an announced date, the bids are opened publicly. Representatives of the bidding companies are present as well as representatives of numerous other companies who are interested in obtaining subcontracts from the winning bidder who will be the prime contractor. The prime contracts are awarded, as



FIGURE 143

a rule, to the lowest bidder, but other factors are also considered. This is why initial reports of contract awards always refer to the "apparent low bidder." Some of the things considered are the company's professional standing, its financial responsibility, and, in many cases, whether its experience in the past makes it reasonably certain that it can successfully handle the work involved. If the awarding agency, say NASA, concludes that the lowest bid is too much below the government's estimate, and that the company could not meet the specifications at the prices quoted, the agency may award the contract to another bidder. There are also times when a contract may be negotiated; that is, the awarding agency may, for a variety of reasons, request a 'sole source' to quote prices for a particular contract.

Most contracts contain incentive and penalty clauses. If the contractor completes the work in less than the specified time limit or if the project exceeds performance standards, he may be paid extra under the incentive clause. On the other hand, if the contract is not completed on time, the contractor may have to pay a penalty for every day the contract is late. Sometimes factors over which the contractor has no control, such as labor strikes, adverse weather, etc., contribute to delays. These and other factors, plus inflation, may also contribute to cost overruns, so that the actual contract cost may be far greater than the original bid.

The important thing to remember about all of this conglomerate of air and space activities, which involve both Federal and civil parts, is that an extensive amount of coordination and cooperation is necessary and is an ongoing process. Too, the process is not without its problems, because special interests, personalities, and an occasional quest for power tend to cause conflict. Even so, such conflicts have not kept our nation from progressing in the aerospace field and probably never will.

# CHAPTER 8

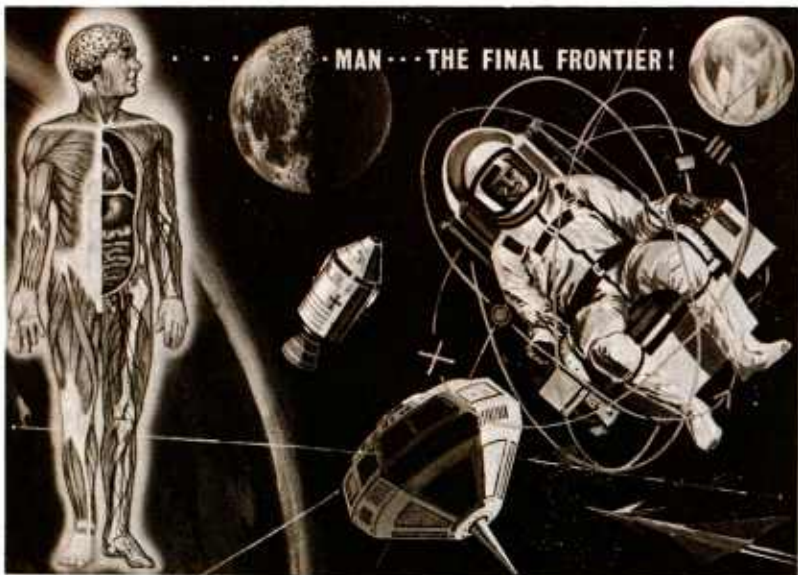

FIGURE 144

SOCIETY AND AEROSPACE DEVELOPMENTS

Most Americans do not realize that their high standard of living now and the even higher standard of living yet to come are directly attributable to aerospace developments. When we speak of *aerospace* (air + space) developments, we mean everything that has or has had anything to do with flight activities—from atmospheric balloons to deep space probes.

In this one small chapter, we cannot enumerate all the impacts that aerospace developments have had on society, but we can provide examples in several general areas. The areas chosen are transportation, communications, navigation, education, medicine, and products. Again, our discussions will be only overviews, but it is hoped that you will be able to use the information presented in your discussions with other people. You can point out to these other people the benefits they have received and are receiving from aerospace developments. If you do this, you will be helping to educate others.

## TRANSPORTATION

Travel by air is commonplace now. Millions of people use air travel each year because of its speed, convenience, and safety. But how does this affect society? For one thing, it allows people to go to places that they would not visit if they had to rely on slow surface transportation. And just the visiting of these far-flung places and meeting the people who live there allow an exchange of ideas and an understanding of how others think and live. We might add here that the combined factors of relatively lower costs in money and time make air travel the most practical type of travel.

The speed of air transportation makes it possible for people to visit several other nations around the world in a week's time, whereas only a few years ago a similar trip took months to accomplish. Too, the transportation of goods—freight—is likewise speeded to points all over the world. Certainly air transportation of goods costs more in money than surface transportation, but it is much cheaper in time.

What has been learned and developed while perfecting devices for air transportation has aided directly in the improvement of surface transportation vehicles. Developments in aerodynamics have led directly to the production of what are known as “hovercraft.” These boat-like devices ride on a cushion of air that is produced by downward-thrusting propellers. The craft does not touch the surface, but it is amphibious. It can travel over a smooth land surface and over al-



Hovercraft boat (top) and Hydrofoil boat (bottom)



FIGURE 145

most any type of water surface. With another set of propellers pushing it, the hovercraft can travel at speeds of more than 60 miles per hour. This is more than twice as fast as the conventional boat.

Again, using principles of aerodynamics for water travel, hydrofoil boats provide much faster travel than other types of boats. The hydrofoil has wing-like surfaces attached to its hull. As the boat gains speed, the hydrofoils react in the same manner to the water as an airplane's wings do to air. In other words, the hydrofoils lift the boat's hull from the water. This reduces the great amount of drag that is present when the entire hull of a conventional boat is moving and in contact with the water, so it allows much faster speed. Strangely enough, hydrofoil boats are not new, but are only now being used to any extent. Dr. Alexander Graham Bell built a hydrofoil boat back in 1918 which could travel at 71 miles per hour. The only drawback to this type of surface vehicle is that it must have relatively smooth water, so its operation is restricted to sheltered waters. Also the hydrofoil boat cannot be operated in waters where there is likelihood of debris, because contact at high speeds with a floating log would be disastrous.

Rail transportation, trains if you prefer, have benefited from aerospace developments too. Some trains just now in the developmental

stages are suspended above the surface of their rail in a manner similar to hovercraft. This type of train uses a special track system. Made of concrete, the track provides a smooth surface against which blowers can push and suspend the train on a cushion of air. Forward motion for this train can be provided by several types of propulsion systems, from propeller/engine devices to jets.

Materials developed for aerospace vehicles now are being used in the construction of surface transportation vehicles. Lightweight aluminum alloys and other metals are used to reduce the weights of high speed boats and trains. The weight reduction provides more speed because the effect of gravity is lessened. Similar materials are used in containers which house and protect goods that are shipped by surface transportation. Use of containerized shipments helps speed the surface (and air) transportation of goods because handling time is reduced greatly. In other words, once the various types of goods are packed into a lightweight container, they do not have to be unpacked until they reach their final destination; no longer is it necessary to waste time removing individual small boxes of goods from a truck and re-stacking them in the hold of a ship or the cargo area of an airliner—all the boxes are moved at the same time in their container.

Everyone associated with air transport and surface transport activities will have to admit that our nation has problems with both. We can fly quickly from point to point, anywhere. But landing at and getting to and away from these points can be trying. One of the reasons that this situation exists is that development of air transport vehicles and the increase in air travel have far outstripped surface accommodations for the airplane and the means for surface travel. Such problems can be solved. We have the know-how as a result—in many respects—of aerospace technology. Let's examine a few approaches to the solutions of these problems:

The obvious solution to bottlenecks created by too many transport (passenger and cargo) airplanes converging at the various airports at one time is to build more airports, and to use aerospace-developed advanced controller devices to space more efficiently the flow of this air traffic. Even when this is done, it will take faster and more efficient surface transportation devices to move the passengers and cargo to and from the airports. Helicopters and short takeoff and landing (STOL) airplanes are being used now to a great extent, but more has to be done. The high speed trains, and even the hovercraft mentioned above, can be used to further this aspect of transportation.

Surface transportation problems are even more acute as one moves nearer to the center of metropolitan areas. Many intricate highway systems have been built to accommodate automobile, bus, and truck traffic, but these highway systems seem ever to be falling behind the growing numbers of vehicles that use them. Can aerospace developments help here? Yes. Using aerospace technology, safe and comfortable mass transit vehicles can be built that will be fast and will attract the traveller. Most people would rather not be bothered by driving their own cars if they can use something better. For those who must use their automobiles, the means are available to guide and space them automatically along the existing freeways, thereby eliminating rush-hour traffic jams.

For those who want to travel short inter-city distances—a hundred miles, say—a new type of subway or tube-train can be built. Of course, the tube-train would be more efficient over long distances because, theoretically, it could travel at 350 miles per hour. In any event, the tube-train design uses aerodynamic principles for its propulsion; too, the tube in which the train would travel could be placed either below ground or above ground.

Whatever the future brings in better surface or subsurface transportation systems, it is certain that the designers and manufacturers will borrow from aerospace technology.

## COMMUNICATIONS

Of benefit to all types of electronic communications are the devices developed especially for communicating with space probes, satellites, and manned space vehicles. One main factor by which aerospace developments have influenced communications is miniaturization. In the early stages of space exploration, the United States simply did not have rocket boosters large enough to send up heavy satellites, so it was necessary to pack a great deal of equipment in a small package. This requirement led to microminiaturization of electronic devices, which, in turn, led to tremendous capabilities of the satellites that now go into orbit.

Every day now we see pictures and hear voices that have been transmitted from one point on earth, to space, and back to a different point on earth. Without communications satellites this would not be happening. But of greater interest is the further development and sophistication of “aerospace” communications systems and the eventual

FIGURE 146

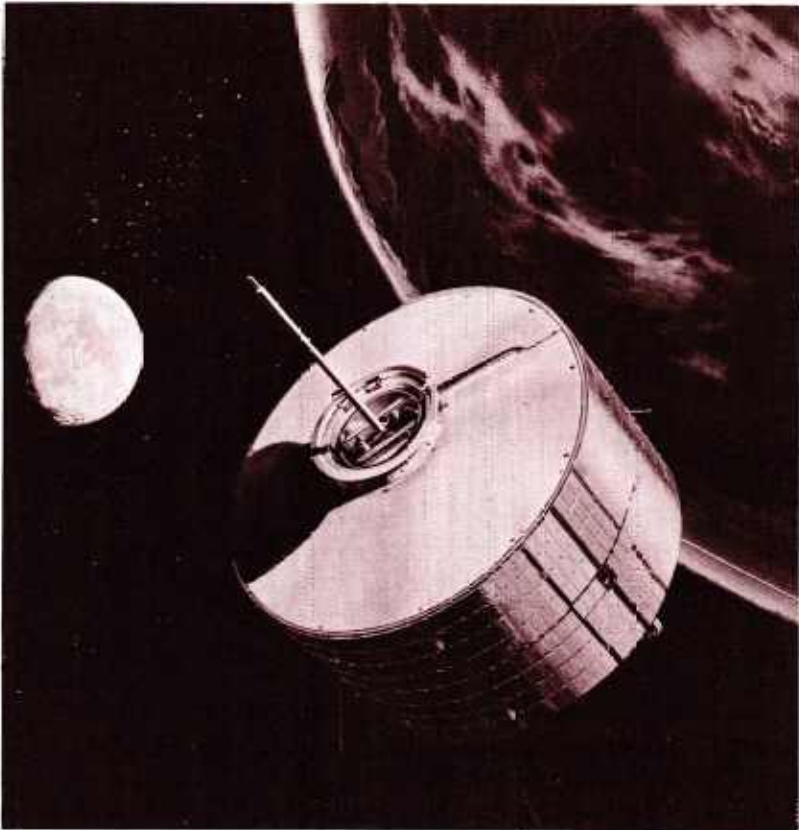

complete tie-in of all peoples on earth. We are bold indeed to make this latter statement. Yet it seems safe to make the prediction because communication by satellite systems is more economical than any other means. For instance, one type of communications satellite provides 1,200 communications channels and costs only half as much as is required to maintain similar communications services of the cable type; too, the cable's channel capacity is only 720 circuits.

At the moment, the greatest drawback to a world-wide, every-home communications system is the equipment needed to retransmit signals received from satellites. First, there has to be a large antenna, or antennae, to receive the signals from the satellite, and these signals must be amplified and retransmitted to other stations for broadcast to "us." This is no problem within the United States, but it is in many other

countries. With improved systems and power for communications satellites, the intermediate ground facilities can be by-passed, and signals direct from such satellites can be received in homes all over the world.

Aerospace research and development have provided the technology. In other words, the communications system or broadcast system can be put into service. It will take money, time, and agreements among nations before such a system becomes operational. When it does, however, think of how much can be learned about other peoples of the world, and think how much closer the population of this planet will be as a result of the visual and aural exchange of cultures.

### NAVIGATION

Satellites, again, have been providing points of reference for surface and air navigation. This has been in effect since 1962. The role of the navigation satellite has just begun, however. It is possible for satellite systems to provide the means of controlling air and surface traffic, and the means of navigating across expanses of the earth's surface to almost any place desired. This system would allow a great increase in point-to-point navigation capability because such satellites furnish an unchanging reference.



FIGURE 147

Improvements in and extensions of the satellite navigation systems probably will not be of much benefit to the average general aviation pilot for many, many years. This is because of the expensive and special equipment that the general aviation pilot would have to purchase. Yet, it may not be too distant in the future when the general aviation pilot's flight over long distances and by instrument flight rules (IFR) will in some way be controlled with the assistance of navigation satellites.

## EDUCATION

Aerospace developments have influenced and assisted education in many ways. These developments have been a tonic for the total education process because they have shown the importance of knowledge and of skills preparation for further developments. In effect, the developments have shown educators how little we know, and have inspired them and their students to do more.

Today, the first graders are using aerospace-age vocabularies; fifth graders are charting the universe and learning about such things as propulsion systems. They are learning things that once were reserved for college students. Granted that this knowledge does not qualify them to design, build, or test propulsion systems, but it at least acquaints them with the world that surrounds them. Also it gives them a basis upon which more like knowledge can be built.

The miniaturization of electronic devices has benefited education because sophisticated teaching aids can be obtained and used economically. Programmed instruction devices allow self-study techniques complete with pictures and sound. Entire states and regions, tied into educational television networks, can use information and programs relayed by satellites. Computers and linkups for accessibility to computers allow even high school students to solve problems with these aerospace age devices. Even the books that are printed and the pictures that are developed and shown in the classroom have been affected by aerospace technology in that they can be reproduced faster than ever before.

Metals, plastics, fabrics and other materials from aerospace developments are found in classrooms and laboratories. In fact, it probably would be difficult to find an article that has not evolved from or been improved by aerospace developments.

Even the subject matter taught in schools has been radically affected. Many new things have been learned about the planets and nat-

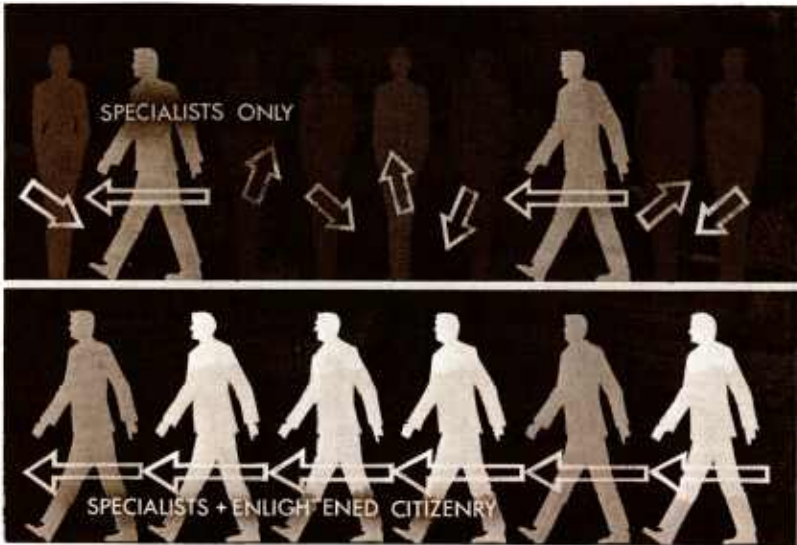

FIGURE 148

ural satellites in our solar system. We have found, for instance, that the earth is not as “round” as once was thought, and the location of certain places is different from what was shown on older maps. New information is being gathered about the composition of the atmosphere, location of natural resources, and so forth. This new or revised information has to be placed in the subjects studied in schools, so it is a continuing process of updating the old with the new—rewriting the textbooks, redrawing the maps, etc.

Beyond the primary and secondary schools, aerospace developments have had tremendous impact on the educational system. Technical/vocational schools have had to adjust their curricula to teach construction and maintenance processes that are applicable to improved engines, airframes, and electronic systems which are used by the new and improved aerospace vehicles. Many university students are actively engaged in research programs which have to do with aerospace medicine, astrophysics, and propulsion systems. At selected institutions of higher education, rocket test facilities, cyclotrons, and space laboratories have been built with which advanced research is conducted; from such programs, universities have made significant contributions to aerospace developments.

Looking into the future, aerospace developments could cause a radical change in our total educational system. With further improve-

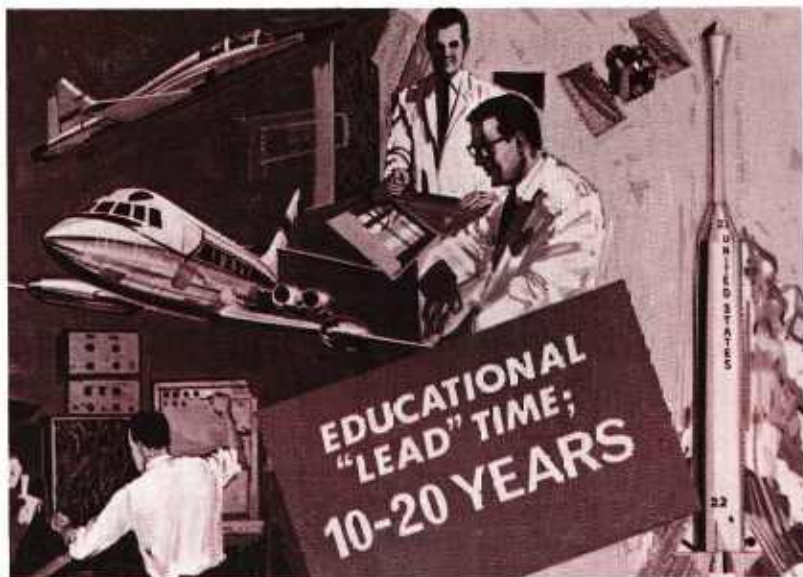

FIGURE 149

ments in the now-used mechanical "teaching machines," coupled with better educational television, it just might be that most primary, secondary, and selected university courses will become self-study types. Indeed, this would be a radical change for many people because only a fraction of the conventional classrooms would be needed. Of course, there probably would have to be a convening of students in laboratory sessions for various science courses; too, the students who chose to be technicians would have to have facilities in which they could practice and become proficient in the required manual skills.

Exactly how aerospace developments will affect education in future years we can only guess. But judging from past and present experiences we can safely say that education will not be by-passed!

### MEDICINE AND HEALTH

By-products of aerospace developments have gained great favor with medical and health personnel. From developments in plastics and pneumatics, we now have inflatable hospitals that are completely air transportable, and are particularly useful as military field hospitals. Also these types of hospitals are ready for use in areas where disasters have occurred.

Cost analysis and other management techniques which evolved during massive aerospace efforts have been applied to medical facilities and have resulted in improved services to patients and less workload for medical personnel. For example, many hospitals are using remote sensing devices, developed for manned space flights, to monitor the physical conditions of several patients at one time. This allows a nurse/physician to evaluate the conditions of patients from a single point, or console, and provide immediate assistance when needed. In fact, it is now possible to detect physiological problems even before there are any outward signs recognizable to even the patient. You can see at least two benefits: One, assistance reaches the patient in record time, and time is the deciding factor with certain physiological malfunctions, and, two, a smaller medical staff can provide care to a larger number of patients.

The development of new materials has led to more disposable devices for hospitals. Rather than maintain huge laundry facilities, hospitals use disposable linens and patient garments. Even certain surgical instruments are sterilized and prepackaged in a sterile environment so that they can be used and discarded. The same is true with hypodermics, so the requirement to maintain accountable stocks of such devices and facilities to sterilize them no longer exists, and costs are reduced.

In the operating room, aerospace developments certainly have had noticeable impact. Work in cryogenics (super cold) has led to cures of certain diseases associated with the human brain. Laser devices, which initially were intended for communications, are being used to repair detached retinas and to destroy tumors in human eyes. Also, the laser is being used as a surgical knife. Its intense force and heat can sever like a knife and at the same time cauterize blood vessels so that there is little or no bleeding.

Even the pressure suit systems built for high altitude flight have found further use in helping people with extremely low blood pressure to lead fairly normal lives. Without the use of the pressure suit system they would be bedridden because they would lose consciousness upon standing.

Developments in ultrasonics have led to medical use of an ultrasonic "needle." It isn't really a needle but a thin beam of high pitched sound waves which can push medication applied to the skin into the body.

Special plastics and metal alloys are replacing damaged parts in the body's circulatory and skeletal systems. Microminiaturization has led

to improved and less costly monitoring equipment, especially in the operating room.

Research for vehicles to be used on the moon has provided the ability to build “walking-type” vehicles for people who have lost the use of their limbs. For those patients who cannot move their arms or legs, the sight switch can be used in a variety of ways. Worn like regular eye-glasses, the switch detects eye movement and, in turn, can open and close switches that operate electrical devices. Already the sight switch has been used to control the movement of motorized wheel chairs.

There are many, many other areas in the medical and health fields which have reaped the benefits of aerospace developments. Were it not for these developments, thousands of people who now are living productive and contented lives would not be so fortunate.

### PRODUCTS

We have discussed several ways that aerospace developments have improved major activity areas such as transportation, communications, and so forth, but what about the mere everyday things? It is now practically impossible for you to look around your own house and not find something that has not been favorably affected by aerospace developments.

FIGURE 150



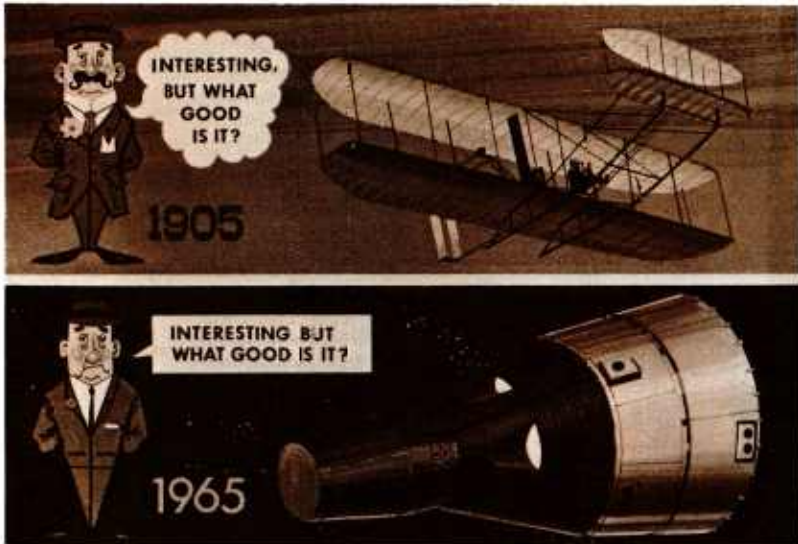

FIGURE 151

If you build and fly radio-controlled model airplanes, you can thank aerospace developments for the very sophisticated and reliable electronic equipment that you use. Too, the plastic parts, the paint, and many other features of your model have been influenced by aerospace developments.

Perhaps you are not wearing them now, but you can purchase eyeglasses that are made of photochromic plastic. This plastic is highly sensitive to sunlight, and darkens rapidly when exposed to it, so the eyeglasses serve as sunglasses too. This same plastic can be used as window panes (once it becomes more common and less expensive); this will allow the homeowner to retain his view while reducing the amount of the sun's heat and light that enters the house.

In your kitchen are many more "aerospace" articles. Perhaps there is a microwave stove that cooks in a few minutes foods that once took hours. Perhaps your conventional heat stove has the automatic cleaning feature, which changes grease spatter into ashes. In all probability your washing machine has many automatic speeds that help clean clothes better and is the result of control devices developed for the space program. Soon even this improved washer will be ready to be replaced by an ultrasonic washer device which now cleans aerospace parts but will do the laundry equally well.

Look at your television and radio. They have parts that are a direct result of aerospace research. They have printed circuits and transistors instead of wires and tubes. Their internal parts do not use as much electricity, and they do not get as hot as older models so they last longer and require fewer repairs.

Just around the corner are things to make our lives even more interesting. It is possible that we will have a home computer that will prepare the budget without error, pay the bills, deposit a predetermined amount in the savings account, and tell us how much "money" is left for additional purchases and recreation. (The computer could do wonders with homework!) Quite likely, each home will have its own power unit that functions for years without refueling. Telepicture telephones will be commonplace. Meals will be prepared in seconds. In other words, our life styles will be radically different.

All of this is not going to happen overnight, even though technology is ready. Why? We must consider the effects of change in relation to society and the environment. If there are thousands of people involved with the manufacture of one product, and a newer and better type is thrust upon the market all at once, thousands of people are in deep trouble; most of them have to find new jobs, and this hurts the economy. What is necessary is a gradual phasing in of the new product so that the transition is as smooth as possible. Let's take an example: If tomorrow the home power unit mentioned above were available to everyone for \$2,000, what would happen? Almost everyone would buy one because they would no longer have to pay electric bills; they would not be affected by power outages; and those unsightly power lines across the yard could be taken down. Fine. Yet, there are thousands of people who earn their livelihoods from working in the power generating plants, erecting and maintaining the power lines, and so forth. Then there are others who work to make the wire and other components used to build the power plants.

We can conclude, then, that a go-slow transition to better things is necessary because of all the factors to be considered. At the same time we can thank aerospace developments for making these better things possible.

# CHAPTER 9



FIGURE 152

PREPARATION FOR THE AEROSPACE AGE

## INTRODUCTION

From the information presented in other chapters, it should be evident that our present-day aerospace society is complex and dynamic; also, that it will become more complex as technology advances and population increases. We discussed briefly in Chapter 1 the difference between aerospace education and training. Aerospace education will be covered more extensively in a subsequent text (Challenge of Aerospace Power), while this chapter will deal with training.

The one thing aerospace has produced, more than anything else, is change. The advent of space exploration in 1957, coupled with the beginning of commercial jet aviation in 1958, created an environment where, for the first time in man's history, the quest for knowledge became a nation's greatest industry. Suddenly, it was not only acceptable, but actually popular, to do research, and the effect of this is what many have called the knowledge revolution. The electronic computer was developed, refined, and improved to enable man to store, refine, and analyze the tremendous amount of data created by aerospace-related industries. During the first decade of the space exploration program, man created more new knowledge than he had in his entire past history.

This quest for knowledge created a great demand on our education community. We needed, and we still need, more and better trained people to work in our aerospace community. It goes without saying that the highly technical nature of aerospace demands training beyond the high school level. Let's look at some of the advanced training available for persons interested in courses in aerospace.

## JUNIOR COLLEGES

The junior colleges or community colleges, as they are sometimes called, have become very popular in recent years, and more and more are being built every year. Why the popularity? The junior colleges are dispersed within the various states to make them more accessible to prospective students and therefore less costly; students can live at home and commute to school. Also, the junior college attendee is more likely to find a job to pay for, or help pay for, his education at this level.

Junior colleges offer the same courses that one will take during the first two years at a four-year college, and at most of them, students can specialize. For example, many provide a two-year education that

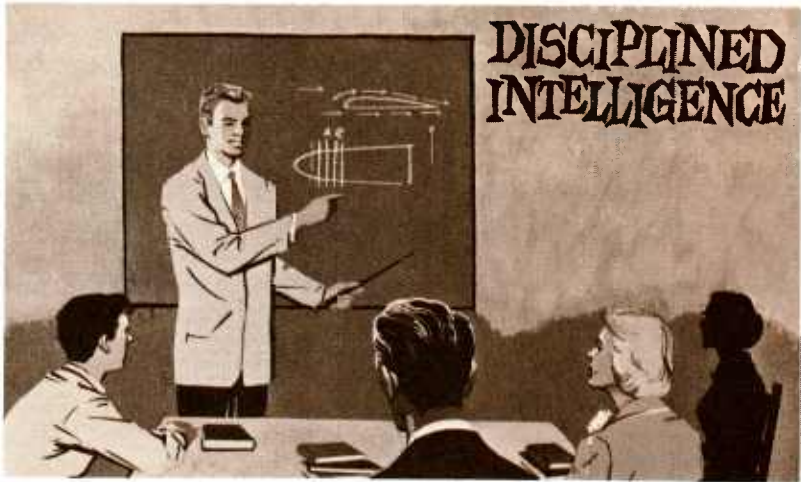

FIGURE 153

is especially tailored to the future engineer (aeronautical or otherwise), or to the future physician. Credits earned in this manner are transferred to a four-year college or university, and the student proceeds to earn his degree

Other than basic preparatory courses of study which are common to further study in engineering, medicine, business, etc., the junior colleges offer special *terminal* courses. These terminal courses will vary from college to college because they usually are established to fulfill the needs of prospective employers (industries) found within a local, state, or regional area; however, as a result of the growth of new technologies created by aerospace developments, more and more junior colleges offer courses that prepare students for vocations in the aerospace industry (air transport and aerospace manufacturing) and related fields (government and military).

Common to most of the junior colleges will be a continuation of studies in language, mathematics, history and certain other subjects that were begun in secondary school. In any event, the amount of exposure to these basic subjects will depend on which of the curricula a student chooses. Curricula designed to prepare students for studies beyond junior college level do place more emphasis on basic subjects. On the other hand, those curricula that are highly specialized and terminal (non degree) place more emphasis on the subjects in which students will specialize.

## TECHNICAL/VOCATIONAL SCHOOLS

Technical/vocational schools provide the majority of formal technical educational courses. In this type of school, many people learn the special trades and skills that are applicable to the aerospace industry. If a person plans to become an aircraft welder, an electronics technician, or an aircraft powerplant mechanic, he should seek out the nearest technical/vocational school and obtain details on what the school has to offer. Let's take a quick look at what you would study if you were to decide to specialize as an aircraft airframe and powerplant mechanic:

- Aircraft basic science
- Aircraft sheetmetal
- Aircraft woodwork
- Aircraft welding
- Aircraft electricity
- Aircraft powerplants (introduction)
- Induction, fuel and oil systems
- Aircraft propellers
- Aircraft hydraulics and pneumatics
- Turbine-engines (operation, maintenance, overhaul)
- Covering and finishing
- Assembly and rigging
- Auxiliary systems
- Radio, electricity and instruments
- Powerplant installation and test
- Repair stations (organization, management and operation)
- Rocket engines

How long does it take to complete a course of study such as the one described above? Again, about two years. This time can be shortened to perhaps fifteen calendar months if the student continues his studies without a vacation break.

People who graduate from this type of school go directly into the work force of private industry or government. There usually is a short period of further training sponsored by the employer. This is because, if you will remember from Chapter 4, no two companies use the exact same manufacturing or work procedures, and the new employee's skills must be adjusted to his employer's methods of doing things.

## INSTITUTES

At various locations across the country, special schools offer only those courses and degrees which are designed specifically for careers found in the aerospace field. This type of school probably uses the title "institute," but may be termed school, college or university.

Institutes, like the technical/vocational schools and terminal courses in junior colleges, place more emphasis on subjects that are essential to doing the job that the student is preparing for; however, there will be several courses in the humanities (rather-than-science subjects) which help give students a more well-rounded education.

Students attending an institute may concentrate in engineering, aerospace engineering, electronic engineering, mechanical engineering, aeronautical engineering, aircraft maintenance engineering technology, aviation management, and mathematics.

Aerospace engineering is a fairly new curriculum which has evolved because of space developments. This type of engineering education prepares a person to work on either aircraft, shuttlecraft, or spacecraft design and production programs—hence, the title "aerospace." Listed below are the subjects to be mastered over a four-year period by the aspiring aerospace engineer:

### *Freshman and Sophomore Years:*

- English composition and literature
- Economics
- History (U.S.)
- Oral communication
- Political Science
- Technical report writing
- Chemistry
- Electronic engineering—introduction
- Engineering: orientation, drafting
- Engineering mechanics: dynamics, statics
- Mathematics: calculus, analytic geometry, computer programming, advanced engineering mathematics
- Mechanical engineering: engineering materials and design
- Physics: mechanics, thermodynamics and electrostatics, atomic physics and quantum mechanics

### *Junior and Senior Years:*

- Aerospace engineering: guidance and control systems
- Electronic engineering: electrical network analysis, electronic cir-

- cuits, linear systems analysis
- Engineering: engineering design, engineering economy and systems engineering
- Engineering mechanics: strength of materials, fluid mechanics, aircraft structures
- Mathematics: complex variables, probability and statistics
- Mechanical engineering: thermodynamics, engineering metallurgy, heat transfer

The curriculum shown above is an example taken from one institute. A comparable curriculum for the aerospace engineering degree may be slightly different at other institutes. Language studies in composition, technical report writing, and oral communication prepare the aerospace engineer to communicate with fellow engineers and the public. Of course, the several mathematics courses are essential to physics and engineering studies.

### FOUR-YEAR COLLEGES/UNIVERSITIES

Entry into a college or university is recommended for those who intend to earn a degree and either do or do not know how they will use their education.



FIGURE 154

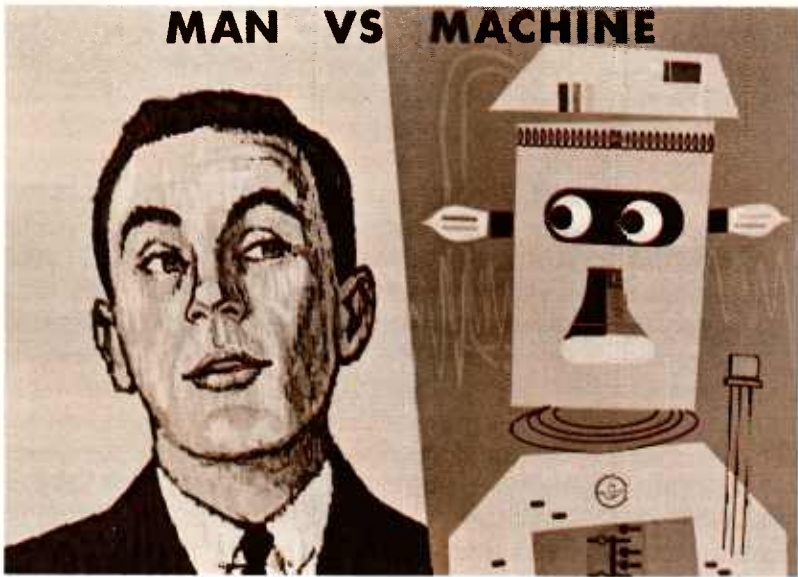

FIGURE 155

The college or university offers a much broader education to its students because they can choose from more electives in both the humanities and science areas. The person who wants to specialize immediately upon beginning the freshman year can do so in somewhat the same manner as found in the institute. Aspiring engineers, for example, begin introductory engineering courses as freshmen. For the person who hasn't decided on a specialized course of study when he enters a college or university, the final decision on his area of major study can be postponed until the beginning of the sophomore or junior year. There is only one drawback to this approach for those who decide on an engineering major: It will take additional study to complete the engineering requirements because of the prerequisite subjects not taken during the first one or two years. This means the total time involved for the basic engineering degree could be as long as six years, if one doesn't plan ahead.

Curricula vary in colleges and universities too. This is particularly true with the elective courses. Today's forward-looking educators have taken steps to help students understand the aerospace world and the changes brought about by aerospace developments. Many colleges and universities now offer courses especially tailored for this purpose.



FIG JRE 156

Some colleges provide flight training as an elective for the entire student body and as a requisite course for certain major fields of study.

At least one university has developed curricula which are especially designed for aerospace careers. This particular institution now affords an *aerospace minor* for students who are majoring in some other subject, and it provides a special two-year program for students who want to become professional pilots but also want to expand their education beyond that needed to master the art of powered flight. The institution also gives credit for pilot certificates earned. In addition to these special courses, a person can receive a bachelor of science degree in either *aerospace administration* or *aerospace technology*, and a master of education degree in *aerospace education*.

The curriculum for aerospace technology was designed for students who intend to become professional pilots or who want to work within the various technical fields found in the aerospace industry. Therefore, it contains a mixture of courses from engineering and other curricula.

Of particular interest is the curriculum for the degree in aerospace administration because it is relatively new and was designed especially to prepare a person for an administrative or managerial position in the aerospace field. Let's see what kinds of courses are given in this curriculum:

*Freshman Year*

Theory of flight  
FAA regulations  
English composition  
College algebra  
Plane trigonometry  
Science  
Technical drawing  
General metals

*Sophomore Year*

Meteorology  
Navigation  
Flight instruction  
Prose fiction  
Poetry  
Science  
American people (history)  
General psychology

*Junior Year*

Propulsion fundamentals  
Aircraft operation & performance  
Principles of economics  
Statistical methods  
Basic electrical fundamentals  
Alternating current theory  
Principles of accounting  
Principles of management  
Data processing  
(plus electives)

*Senior Year*

Aerospace vehicles systems  
Aerospace internship  
Management  
(plus a certain number of electives and the courses needed to complete the requirements for a "minor.")

Note that this curriculum gives the student a very broad but in-depth sampling of courses which pertain to specialized areas in the aerospace field. At the same time it provides a good background in those subjects that a person needs to know if he is to become an administrator or manager.

## GRADUATE SCHOOLS

Beyond the basic degree, whether it is earned in a college, university or an institute, are the master's and doctor's degrees. These degrees have different types of titles according to the specialty they represent. For instance, the masters degree may be M.A.—Master of Arts; M.S.—Master of Science; M.B.A.—Master of Business Administration; M.C.L.—Master of Civil Law, and so forth. At the doctorate level there are also abbreviations which represent certain specialties, but the title of doctoral degrees generally is Doctor of Philosophy—PhD. We might note a major exception to this statement: The degree earned by physicians is in a special, unique category, is titled Doctor of Medicine, and is abbreviated M.D.

Very well, what does all of this mean? It means more study and more time in school, but it also means more opportunity for advancement once the higher degree is earned. Therefore, continuation of studies to earn the highest degree possible is justified from the standpoint of a better future for the individual. Another and altruistic reason for higher education is the contributions a person becomes capable of making to his society and to his nation. Naturally the more informed or expert a person is, the more inclined people will be to listen to his ideas and to accept his decisions. In other words, education *can be* the factor which places a person in the position of leadership among his peers. (Note the emphasis on “can be.” Personality is the other half of the story, because even the PhD who can't communicate with and get along with others will be ignored.)

Graduate study, as stated, requires spending more time as a student. For the master's degree, about one year is required, and for the doctor's degree (M.D. excepted) three additional years usually will fulfill the requirements. One thing that should be pointed out is that a person need not earn the master's degree before going on for his PhD. For those who plan ahead adequately, three years of study immediately



FIGURE 157

following the bachelor's degree usually will be all the time required to earn the coveted PhD.

Now let's backtrack to the master's degree area and discuss the special master of education degree in *aerospace education*, which was introduced under the section "Four-year colleges/universities." The forward-thinking university which grants this degree designed it especially for teachers, future teachers, and administrators in the education field. Why? Because it is teachers who help educate and prepare young people for living in the aerospace society, so the teachers should be thoroughly familiar with aerospace subjects and the effects that aerospace events and developments have on society (and society is everybody). Considering the possibility that your goal will be a master's degree in aerospace education, here is a list of the courses that you probably will study:

- Introduction to graduate study
- Curriculum development
- Supervision of instruction
- Teaching aids
- Educational philosophy
- Problems in education

Comparative education  
Aerospace vehicle systems  
Principles of instrument flight  
Air traffic control  
Air transportation  
Problems in aerospace  
Aerospace science for teachers  
Aerospace internship  
Flight instruction  
Aerospace education workshops

Note that the nature of these courses provides the degree candidate a well-rounded education in matters which pertain to aerospace—including flight instruction. Perhaps we should emphasize that not *all* of these courses will have to be taken—only the number required by the university granting the degree. Some of the courses will be at the option of the degree candidate; they will be electives.

Before going on to our next section, let us summarize briefly the role of education in this, the aerospace age: Society and the occupations or careers found in it are increasing in complexity and require more and more specialization on the part of members of society. To understand and appreciate the impact of aerospace developments on society, everyone needs and should expand his knowledge beyond that



FIGURE 158 FIRST ASTRONAUT TEAM (left to right): Malcolm Scott Carpenter, Leroy Gordon Cooper, Jr., John Herschel Glenn, Jr., Virgil Ivan Grissom, Walter Marty Schirra, Jr., Alan Bartless Shepard, Jr., and Donald Kent Slayton

required by his specialty. In short, the best way in which a modern person can prepare himself to contribute to and lead others in their contributions to society is to become as educated as possible.

The foundation of the education process is formed by secondary school accomplishments, and the two most important pillars of this foundation are English and mathematics. In addition to the formal school courses taken, the student should establish a continuing effort to expand, by his own efforts, his knowledge and understanding of aerospace accomplishments and programs.

The opportunities for advanced and specialized education abound. Technical/vocational schools provide various aerospace skills training; junior colleges offer enrichment, preparatory, and technical courses; institutes specialize in technical education, and they graduate engineers and technicians; colleges and universities offer a wide variety of curricula which include more subjects of pure educational value, along with the technical subjects.

### ARMED FORCES SCHOOLS

The serious, determined student will find that he can get the education that he wants and needs from civilian schools. If his funds are low or nonexistent, the student can work his way through school, borrow the needed funds (to be repaid after graduation), win scholarships, obtain Federal assistance, enter a co-op plan with an industry (student alternates full time work periods with full time school periods), etc.

What many people have done and continue to do is enter the United States Air Force, or one of the other branches of the Armed Forces, and continue their education while serving their country. For those who are not "frightened" by the prospects of leading a military life for four or more years this is a very sensible route to take. After all, the individual's personal and financial needs are satisfied while he is gaining further education and training. In addition, there are various forms of the "GI Bill" which a person may use to obtain more education and training after he completes his service.

There is hardly any need for us to expound on the many, many educational opportunities offered by just the U.S. Air Force. Suffice it to say that there are more than 1,300 courses or schools available to Air Force personnel, plus several ways in which an enlistee or officer can earn a bachelor's degree and go on to earn advanced degrees. Recruiting offices can provide more detailed information.

Why should there be so many educational opportunities in the USAF, particularly? Very simply, every type of activity that has to do with aerospace society is present in the USAF environment, and the schools found in the civilian community simply do not (probably cannot) produce enough graduates to fill USAF needs—even if all the graduates were inclined to join the USAF. Therefore, the USAF must educate and train its own specialists.

Since there is much military aerospace research being conducted, the USAF has to have many engineers, draftsmen, aeronautical engineering technicians, electronics technicians, propulsion systems technicians, and so forth.

There is not a great deal of difference between a military airplane and a civilian airplane, so the aviation technicians trained by the USAF have no trouble finding a comparable civilian occupation. As examples: An Air Force base uses the same types of skills that are found at a large metropolitan airport. There are pilots who fly aircraft that range in size from a small single engine airplane to the huge multi-engine jets. Airframe and powerplant mechanics, and electronics technicians are available to repair and maintain these vehicles. Air traffic controllers supervise the flights to and from the base's airport; this includes tower and radar types of controllers. Then there are many other types of skills and professions which are unique to air and aerospace transportation: Included in these are medical personnel who are specially trained to correct physiological problems that may develop from aerospace activities.

Beyond the typical USAF base, we find special installations which require many other types of technicians and managers. Some of these apply to our satellite programs, and others apply to our defense missile and defense detection systems. Here we find various craftsmen and technicians who have to maintain the facilities structures and the special equipment within the structures.

You should understand that our pointing out the opportunities for the advancement of education and training in the Armed Forces is *not* for recruiting purposes. Rather it is a truth which is open to further investigation by anyone. Another "plus" for USAF training is the opportunity to see and personally experience many aerospace activities that are not common—yet—and therefore not readily available to the civilian student. In short, the Armed Forces educational route is worthy of consideration by all young people.

# CHAPTER 10

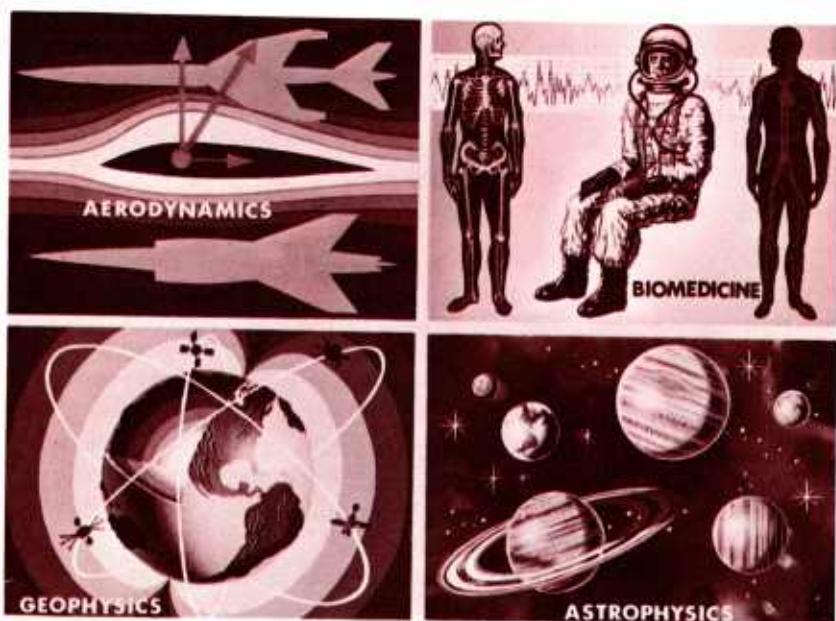

FIGURE 159

AERONAUTICS, ASTRONAUTICS, AND THE  
FUTURE

Here we are in the final chapter of your introduction to aerospace. You have learned something about the history of mankind's struggle to extend his environment outward from the earth's surface. You understand how the vehicles that take us into the realm of aerospace are built. You have been shown the importance of education if one wishes to really participate in aerospace activities. Several examples have been cited to show how important aerospace developments are to society, to our government, and to our nation in the international community.

To conclude this introduction, it seems reasonable that we should try looking into the future. Much of what we see will not materialize for many, many years. This is because, as you have learned, it takes time to develop new materials and techniques for an aerospace program, and there always is a struggle over which way a program should go—if at all. Before we do look into the future, let's find out exactly where we are, in relation to everything else.

## THE REALM OF AEROSPACE

At one time in the fairly recent past, it was conventional to think that the atmosphere ended about 20 or so miles above the earth's surface; that beyond this distance there was nothing but the cold vacuum of space in which other heavenly bodies travelled, and that one would not encounter another atmosphere until reaching one of these heavenly bodies—if the body had any atmosphere. Back during those golden days, not of ignorance but of more limited information, people spoke of air activities and possible space activities.

Further investigation of the upper atmosphere, as the devices for conducting such investigations became available, showed that the atmosphere does not end at any specific altitude. Instead, the atmosphere simply gets thinner and thinner the farther one goes outward from the earth's surface. In fact, we now know that molecules common to our atmosphere—which is composed of oxygen and nitrogen for the most part—are found in what might be considered true space. But this "atmosphere" is thin! There could be several hundreds of miles or more between two of the molecules.

Many people have stopped using the terms air and space separately when referring to the region above the earth's surface. They now use aerospace—combined form of the two terms. More and more you will find that airplanes, which are confined to the atmosphere near the

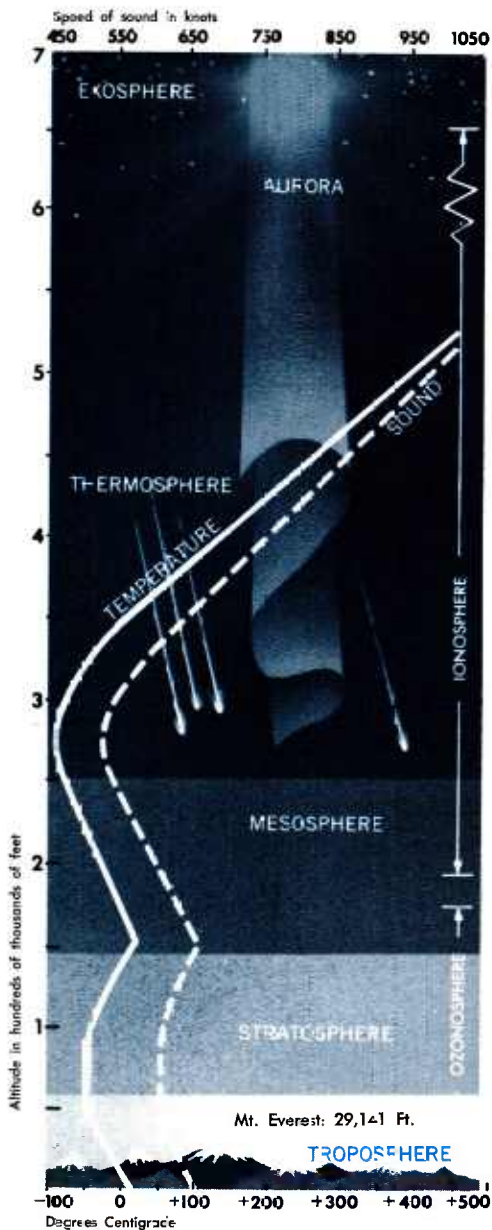

## THE ATMOSPHERE

showing  
TEMPERATURE AND SPEED OF  
SOUND VARIATIONS

When Man leaves the two-dimensional surface of the earth, he enters a three-dimensional environment whose multiple characteristics are fast-changing and foreign to him.

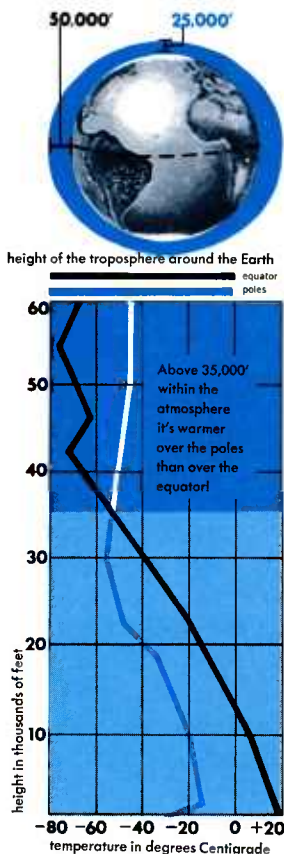

Figure 2

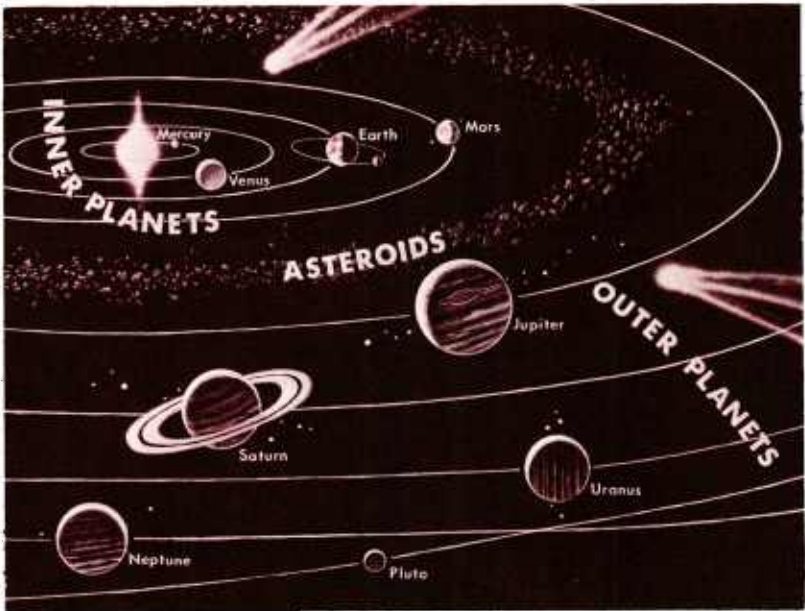

FIGURE 161 The Solar System

earth, and spaceships, which do not operate within the near-earth atmosphere, are collectively referred to as “aerospace vehicles.” This may seem odd to you, yet it isn’t incorrect when aerospace is defined as “an operationally indivisible medium consisting of the total expanse, including air and space, beyond the earth’s surface.” In other words, when you travel outward from the earth’s surface you are traveling in aerospace, no matter how far you go. Too, many types of airplanes flying today travel to areas so far outward from the earth’s surface that the atmosphere, as we normally think of it, is practically nonexistent. With all of this overlapping of flight capabilities, it is simpler to refer to every man-made thing that flies as an aerospace vehicle.

Now that we have determined that air and space are one, where do we fit into this realm of aerospace? If, in going about our daily lives, some of us tend to think of ourselves as being important—even giants among creatures—we have only to place ourselves in proper perspective to the aerospace environment to see how really insignificant all of us are and how much more we must learn to really appreciate our present status.

On planet Earth, our home, it takes us more than 45 hours to travel around the 24,902.4 mile equatorial circumference and back to the

starting point with a fast, nonstop jet. This is great! However, a low-orbit satellite can girdle the earth in only a little more than an hour. Wonderful! We have accomplished what many said couldn't be done, including 500,000-mile round trip visits to the moon. So we as human beings have made giant strides in technology, but it is sobering to peer outward into the far reaches of this realm of aerospace and consider our accomplishments in relation to the universe.

Let's begin with a view from our planet, and consider its environment in relation to similar bodies. As you probably remember from the fourth grade, the Sun is the head of our Earth's family, and we travel around the Sun in an orbit that is about 93 million miles distant. The rest of the family consists of eight other planets: Mercury, Venus, Mars, Jupiter, Saturn, Uranus, Neptune and Pluto—all of which make up the solar system. Brother Mercury is only 36 million miles from the Sun, or center of the solar system, but brother Pluto is 3 billion miles from the center. What happened to our great feat of taking only 45 + hours to fly around the earth or to travel the approximately  $\frac{1}{2}$  million miles to the Moon and Back? Doesn't seem so great now, does it?

Anyway, we and our planet are parts of a tremendous solar system that measures about 7 billion miles in diameter, and that's big! It certainly is, in relation to our planet Earth, especially so since ours is a small planet in comparison to Jupiter, which is about 11 times larger. On the other hand, our solar system is nothing to brag about. Actually, it is a very mediocre system that has a plain fairly small star which we have designated Sun. There are other stars, or suns, so large that most of our solar system would fit inside them. Also, some of the other solar systems have two or more suns. (Are we getting smaller?)

Now if we look outward a little more we find that stars and solar systems most always are a part of a larger family—the galaxy. The galaxy is somewhat like a city in that it is a grouping of solar families. But how big is a galaxy? It is big enough that we can no longer speak of distance in miles because too many miles are involved. Instead we have to use light years, and a light year is the miles that a particle of light can travel in one calendar year. At 186,282 miles per second, the light year equals about 5,800,000,000,000 miles. So far so good. Now the rather ordinary galaxy in which we live has a diameter of 100,000 light years, and we are about 25,000 light years from its center. We're getting smaller all the time, but this isn't the end of the story. It seems that there is an infinite number of galaxies; it has been estimated that there are at least ten billion galaxies visible to present-day telescopes.

(When we say visible to present-day telescopes, we mean that we can see only so many light years into the infinite. Beyond this vision-ability barrier there must be more galaxies and other types of bodies.)

How can these vast bodies and the distances between them be brought into a perspective that is familiar to us? It has been written that if a plane were cut through the visible universe and if the plane were the size of the United States the following relationships would be about right: Our galaxy—the “Milky Way”—would occupy a space about 160 feet in diameter. The nearest galaxy to ours, Andromeda, would be another 160 ft. disk a half-mile away. All the other galaxies within this U. S. sized plane would be spaced about one mile apart (average) and in all directions.

Very well, we now have a mental picture of the spacing involved so let's get back to our 160-foot diameter galaxy. At this size, the light year would represent  $\frac{1}{50}$  of an inch, and the stars, or suns, in our galaxy would have an average size of 1 millionth of a light year. This means that the suns—in this perspective—would be submicroscopic. Adding still more smallness to the picture, the planets which orbit these suns, ours included, could not be seen by an electron microscope!

So this is our position in the realm of aerospace. We are sub, sub microorganisms which have been endowed with abilities that allow us to improve our kind through research and the exploration of that which is around us. As you now realize, we have plenty of room in which to grow and to extend our influence. If we are to grow, we must keep setting goals and working to achieve them. At the same time we should remember our aerospace size so that all we do is in proper perspective. In other words, before we get too involved with our self importance we should look outward and *think*.

## AERONAUTICS

This is the term applied to the making and flying of aircraft which are confined to the thicker, near-earth atmosphere. Very well, we have thousands and thousands of these aircraft. They are fast, efficient, and so forth, so perhaps we have reached the ultimate in this particular area of aerospace activities. Not so. There are many things yet to be done.

Today, and rightfully so, there is great concern over the atmospheric pollution caused by all types of things, aircraft included. Re-

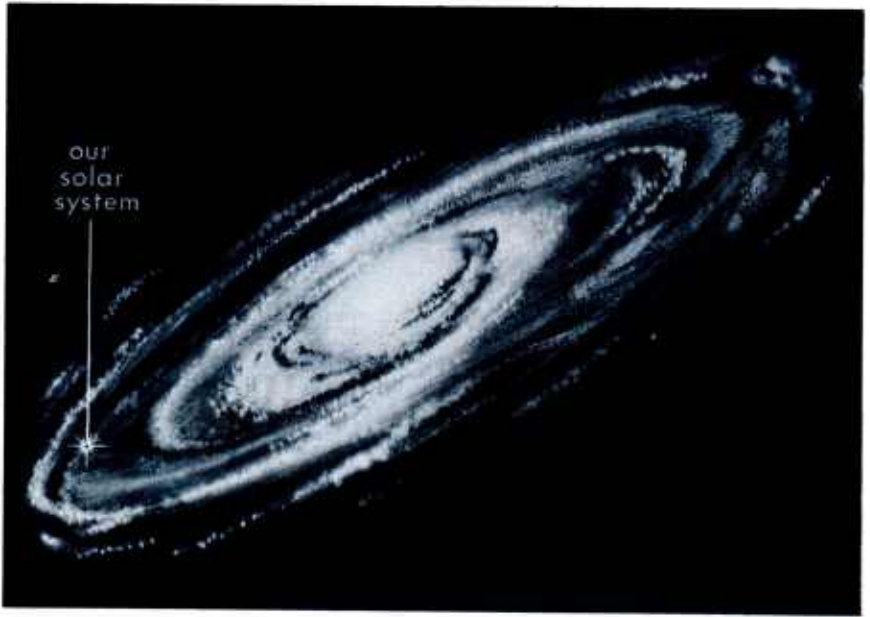

FIGURE 162

search and the development of new devices to be added to aircraft engines is reducing the amount of pollutants discharged by aircraft. Still the goal of no pollution emission must be worked toward and reached.

As world population increases, the demand for air travel will increase. This will mean that even more efficient types of aircraft will be needed, and this factor can take several routes. Supersonic transports (SSTs) can move many passengers in a given time because of their speed. Giant fan-jet powered transports can carry great numbers of passengers, but not at such high speeds as the SSTs. And it just might be that the dirigible will again see service for passengers who are not pressed for time but like to experience the thrill of traveling above the earth's surface.

Supersonic transports have had much bad publicity because of their supposed potential for air pollution and climate changes and the possible adverse effects of sonic "booms" created by them. Whether these scare predictions come about will have to be seen. In the meantime, research centers are working to reduce or eliminate the causes. Further developments such as the super-critical wing and refined propulsion systems will help solve many foreseen and unforeseen problems. (See CAP's *Aircraft in Flight*, and *Power for Aircraft* texts.)

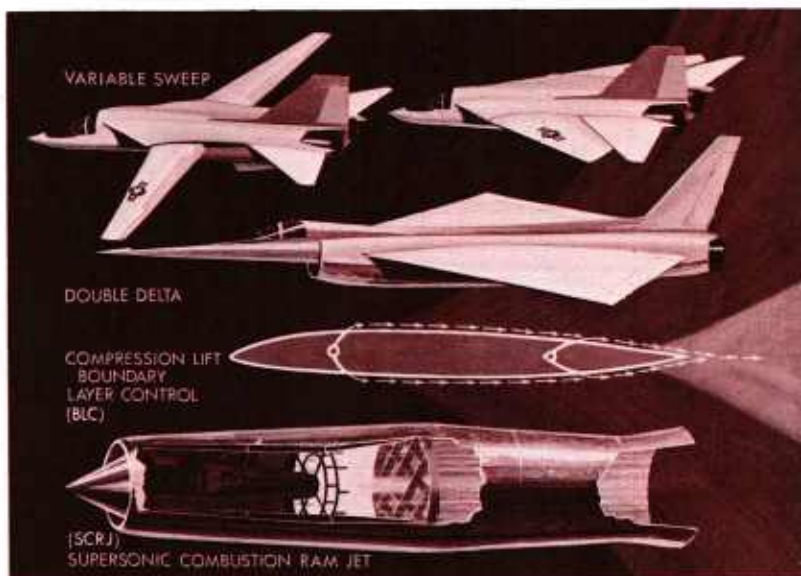

FIGURE 163

Looking beyond a few years, when the SST types of aircraft have become commonplace, a new type will probably be the center of an aeronautics controversy. This is the hypersonic transport. What do we mean by hypersonic? To begin with, the supersonic transport travels at speeds around 1,800 miles per hour. Of course this is at a high altitude where sound travels slower and the SST is flying about 3 times the speed of sound. If the SST were to speed up and go faster than 5 times the speed of sound at the given altitude, it would become a hypersonic transport (HT).

The building and flying of HTs, however, is really speculative at this point. It is more probable that vehicles of this type will have more application in the reaches of "higher" aerospace.

Of interest to you in a more personal way will be further developments in the aircraft that you fly as pilot in command. To most aerospace-minded people, this is the small general aviation type airplane similar to the Piper Cherokee line that "we built" back in Chapter 4. What keeps many people from learning to fly and buying their own airplanes is the cost. Just paying for the instruction portion of flight lessons isn't so much, but rental costs are fairly high (per hour), and

these rental costs are the result of the initial purchase price of the airplane. Yet, things are looking better.

New materials and approaches to the uses of old materials are now being employed in the construction of light airplanes, and it looks as if new types could come within the price range of a medium sized car. When this happens, many more people will be able to afford their own airplanes, and they will be spending more time in the air. What effect just this increase in air traffic will have on government and society will have to be seen.

Now let's go a bit farther out from the earth's surface into the area of astronautics.

## ASTRONAUTICS

Astronautics differs from aeronautics in the type of vehicles used and the techniques of "flying" them. This is because such vehicles operate in the realm of aerospace where there is no appreciable atmosphere—in what is conventionally called space. The people who venture into this area are known as astronauts in the United States and cosmonauts in Russia.

Thus far, mankind has hardly begun to venture into what is the most challenging frontier yet probed. As was indicated in our discus-

FIGURE 164



sion above, the frontier is without end, and mankind can't ever hope to explore all of it. This is what makes the whole thing so exciting; we have at last a frontier that awaits exploration by anyone and will be available forever.

Orbiting earth, making soft landings on the moon, and sending probes on circumsolar orbits are magnificent accomplishments and practically unbelievable scientific feats, even to those who are responsible for such activities. Yet, to you scientists and astronauts of the future, the events of today will seem very elementary because you will accomplish so much more.

Just within the lifetimes of your grandparents, the problem of heavier-than-air flight was solved. Then came the challenges of supersonic and hypersonic flight, the heat barrier, and a propulsion system powerful enough to allow escape from earth's gravitational field. All of these challenges have been met and mastered. What will be accomplished in your lifetime cannot be predicted with certainty because it will be left to you. But if your generation wants to explore any appreciable amount of aerospace, you have the greatest challenge of all—how to attain the speed of light. We will discuss this factor a little later, but we should first look at what we have now.

FIGURE 165 Vanguard satellite over Florida, looking Northeast

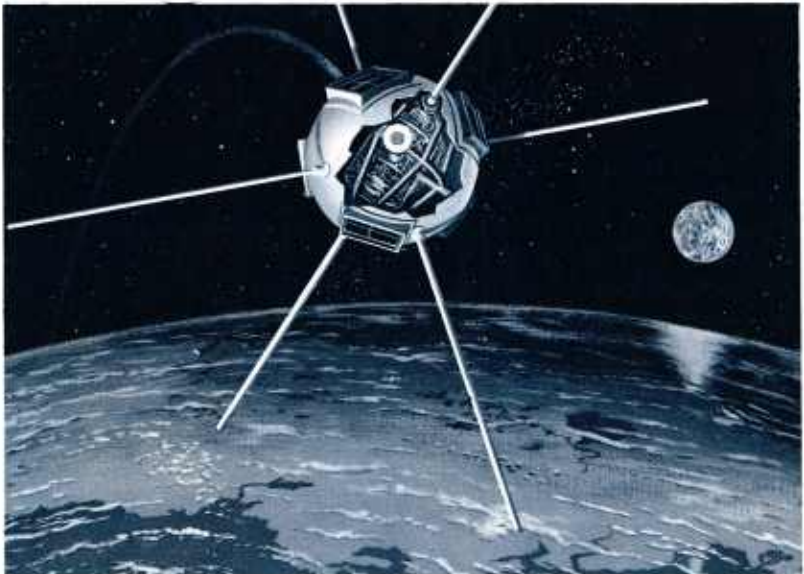

UNMANNED SPACECRAFT. There are thousands of spacecraft in its broadest sense. Actually, a spacecraft should be thought of as being a maneuverable craft that is sent into space to perform some specific function. What has happened though is that there are many rockets and pieces of rockets up in space that are not performing a function. Yet they *are* traveling through space and deserve to be called spacecraft, literally. Actually, anything in orbit that has no further use or is incapable of gathering information becomes *space debris*.

For a little history: Our first spacecraft, or satellite, went into earth orbit on the 31st of January 1958. (It had been preceded by the Soviet Union's Sputnik I on October 4, 1957. The Soviet accomplishment spurred the American public to support an active program of space research, technology, and exploration.) Explorer 1, as it was designated, weighed almost 31 pounds, and its mission was to gather information. Its instrument package contained a temperature detector, cosmic ray detector, a microphone to detect collision with meteoroids, a gauge to measure erosion by cosmic dust, and a radio system for transmitting back to earth the information gathered. Explorer I discovered the Van Allen Radiation Belt.

From this beginning, sophisticated satellites now provide round-the-clock pictures of weather conditions on earth. Others serve as relay stations for communications between different parts of the world. Military satellites monitor the activities of a potential aggressor, and can provide early warning of attack. Deep space probes relay messages and pictures back to earth that tell us about distant planetary environments. The service or disservice that satellites can afford mankind is indeed remarkable.

Progress in rocketry has led to multipurpose rocket types: That is, the same type may be used to deliver nuclear warheads to an aggressor's cities or to launch information-seeking satellites into orbit. Rather than a lengthy discussion of the different rockets, suffice it to say that the United States has nine different basic rockets, or satellite launch vehicles (SLVS), for use in our space exploration program. The *Scout* is the smallest. Its first stage thrust of 88,000 pounds is used to send payloads of up to 400 pounds into near-earth orbit. At the other end of the scale, NASA's Saturn V system can place 285,000 pounds into earth orbit or send about 98,000 pounds to the moon.

FIGURE 166

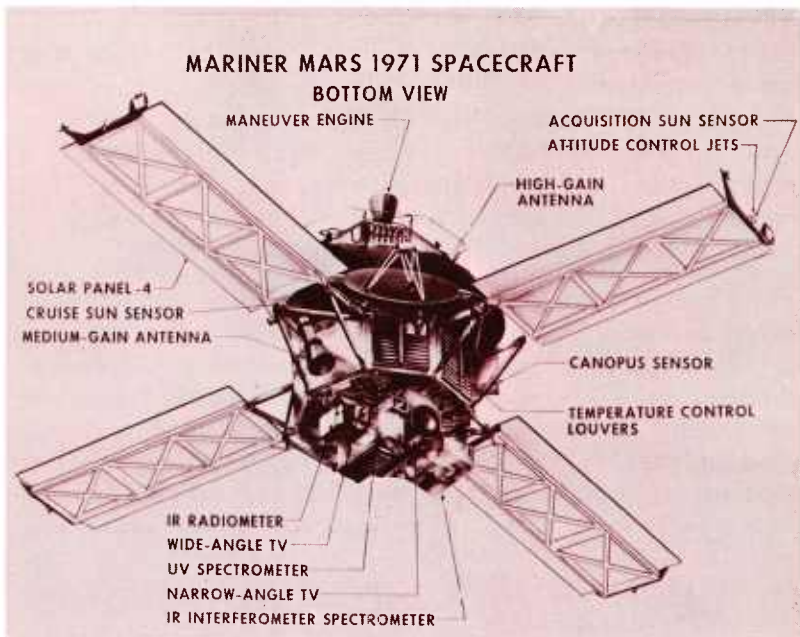
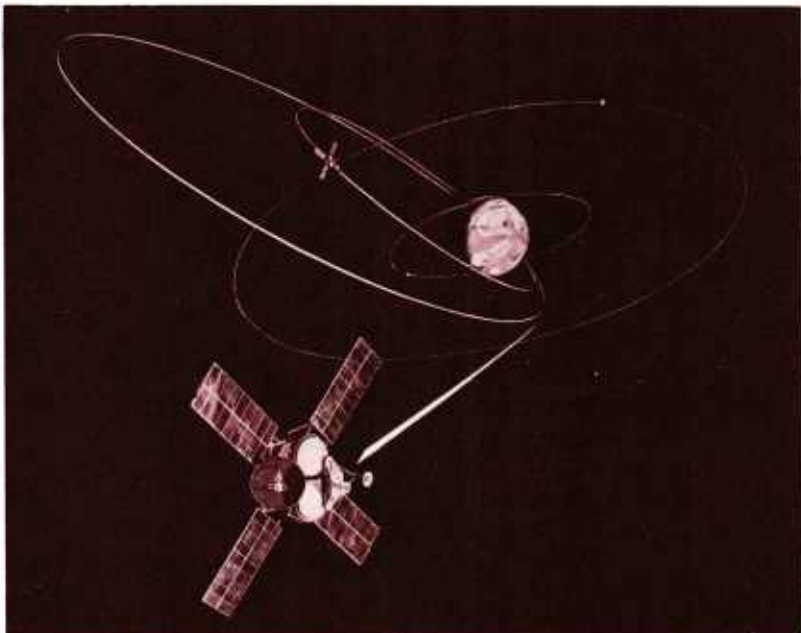

FIGURE 167



Mariner probes circling Mars, showing two Martian moons, Phobos (inner orbit) and Deimos (outer orbit)

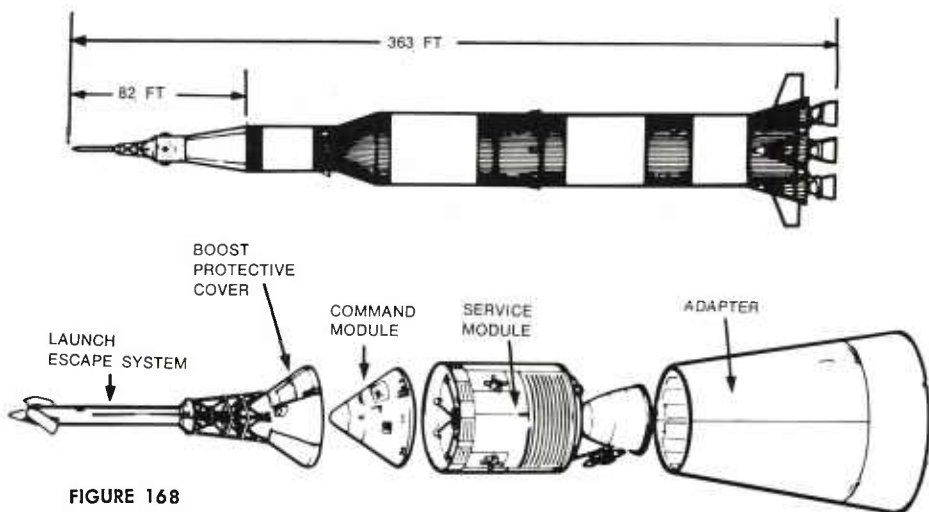

FIGURE 168

**MANNED SPACECRAFT.** The Apollo lunar exploration program is yet the greatest manned spacecraft feat ever accomplished. When we discussed how the Saturn booster rocket is built, we touched on some of the specifics of the huge vehicle. With the Apollo spacecraft attached, the complete vehicle stands 363 feet tall, measures 33 feet in diameter and weighs over six million pounds.

All the Apollo flights began with the 7.5 million pounds of thrust produced by the five F-1 engines in the Saturn first stage. And this amount of thrust is needed to get the vehicle to an altitude of 36 miles and a velocity of 6,000 mph. At this point the first stage is caused to fall away.

The second stage uses its 1 million pounds of thrust to boost the spacecraft speed to near orbital velocity where the third stage takes over with its 200,000 pounds of thrust to place itself and the Apollo spacecraft into earth orbit. After checkout of all Apollo systems, the third stage is reignited and propels the spacecraft toward the moon at about 25,000 mph. The third stage is "burned out" upon achieving this speed, is no longer needed, and is jettisoned.

Without continuing thrust, the spacecraft is slowed to a velocity of 2,500 mph. But this is enough speed to keep it going toward the moon's gravitational field. Once inside the moon's gravitational pull, the spacecraft is speeded up by the gravitational pull, increasing its velocity to over 5,000 mph.

FIGURE 169



Lift off (NASA photo)

FIGURE 170

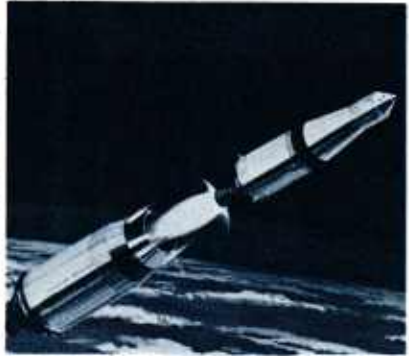

Stage separation (NASA photo)

Obviously this velocity must be reduced, so the service module's engine is retrofired for about six minutes. This slows the entire spacecraft (command, service, and lunar modules) to a lunar orbit speed (3,500 mph), and the command and service modules remain in lunar orbit. It is the lunar module (LM) with its 2-man crew that visits the moon's surface. The LM lower stage remains on the moon. The astronauts take only the upper stage back into lunar orbit and rendezvous with the command and service modules.

After the rendezvous, the LM upper stage is jettisoned and is either left in lunar orbit, crashed into the lunar surface, or fired into solar orbit, while the service module propels the command module on a trajectory back to earth.

The service module's remaining propellant is used for course corrections on the way back to earth. Well before the command mod-

FIGURE 171

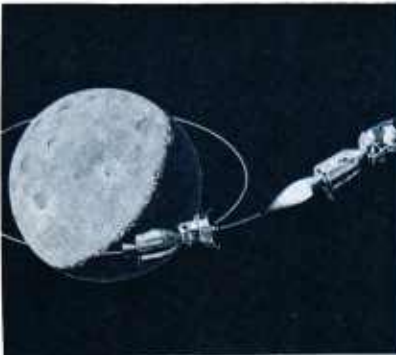

Lunar orbit insertion (NASA photo)

FIGURE 172

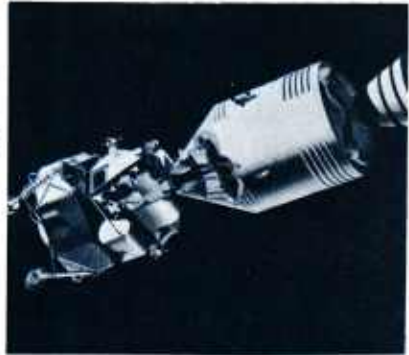

Transfer to LM (NASA photo)

FIGURE 173

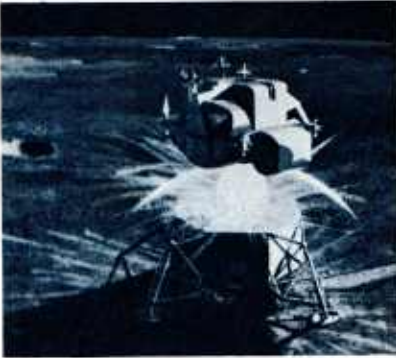

Lift off (NASA photo)

FIGURE 174

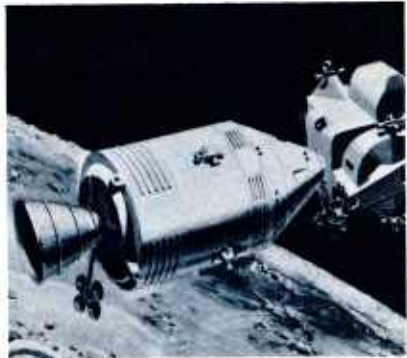

Docking (NASA photo)

ule enters the earth's atmosphere it separates from the service module. Heat generated by the command module striking the atmosphere eats away at the ablative heat shield, but the astronauts stay comfortable while atmospheric drag slows the module enough for its parachutes to deploy. The parachutes provide a soft landing in the ocean where recovery personnel accomplish the journey's last step—that of lifting astronauts and command module aboard a recovery ship.

This has been a brief description of an Apollo "moon trip," which may seem very simple, but it isn't for the people who are involved directly. Think of the training and conditioning that the astronauts must have. In the first place they must be in excellent physical and mental condition in order to withstand the rigors of lift-off, the prolonged state of weightlessness, and the stages of tension at different critical points along the "moon route."

FIGURE 175



Descent (NASA photo)

FIGURE 176



Recovery (NASA photo)



FIGURE 177 Space shuttle

It takes highly educated personnel with agile minds to comprehend the hardware of their spaceship and learn the human countermeasures to possible mechanical failure. Much time is spent practicing the various maneuvers that are necessary to manned astronautics; constant practice enables the astronauts to respond quickly and accurately to any situation they may encounter on their trips.

Within the next few years, more is going to be done in the manned spacecraft area. Permanent manned satellites will become commonplace. We can envision a moon exploration and utilization program much more sophisticated than that of Apollo. Shuttlecraft which will rocket payloads into orbit like spacecraft, and then return to earth, flying like conventional airplanes in the atmosphere, will reduce the costs of space program operations and allow more to be accomplished. Even with all of this we have not progressed very far into the realm of aerospace. Perhaps the analogy is very much out of proportion, but our present status in the exploration of the aerospace frontier is approximately that of the first manned Montgolfiers' balloon flights which began the exploration of the near-earth atmosphere.

Where do we go and how will we get there in future years? No one knows for certain. There are, as you know, an infinite number of planets in other solar systems that await the visit of mankind from planet Earth. But the distances are so great that a lot more progress in propulsion systems and life support systems will have to become realities before these distances can be traversed.

Visiting one of the 12 moons of Jupiter, for instance, is not practical in the near future. At its closest point to Earth, Jupiter is 400 million

miles away. If we had a propulsion system that could sustain our present velocity capability of about 26,000 mph, it would take 5 years to make the round trip. At the same sustained velocity, a round trip to Pluto would take over 30 years. Therefore, we must find a method or methods by which the speed of future space vehicles can be increased and sustained at velocities many times greater than our present capabilities. Too, we have to work out true closed ecology systems which will allow the recycling of life support items, such as oxygen, food, and water. After all, these space vehicles of the future will be gone for a long time, and the volume of supplies carried will have to be limited.

When mankind finally gets to the edge of our solar system, there will be yet another challenge—that of visiting other solar systems. It has been estimated that within our galaxy there are more than 100 billion other suns, and a large number of these suns have planets and thus qualify as solar systems. Now, within these other solar systems it may be that planets exist which are capable of supporting life forms exactly like the ones found on our planet. In other words, the planets are out there waiting to be colonized (if they haven't been already—think about that!)

Going to another solar system has at this time the status of science fiction. Going to the moon had the same status a few years ago. The feat will be accomplished. But first we must have a propulsion system that can propel astronauts at or near the speed of light, and that amounts to about 670 million miles per hour. Even at this optic speed it would take our astronauts 10.9 light years to reach star 61 Cygni which is the nearest star most likely to have planets orbiting it, thus qualifying it as a solar system.

When we speak of travel at this speed, there come to mind many challenges just in the area of navigation. You know that the planets in our solar system revolve around the sun, and so must the planets of 61 Cygni. But in what direction are the orbital planes of 61 Cygni's planets, how far away from the star is each planet, which planet would be the most hospitable, etc.? In other words, exactly where is it that "we are going? This must be known before the spaceship leaves the vicinity and comfort of planet Earth.

Another thing to be considered is the fact that solar systems revolve around the center of the galaxy in much the same manner as planets around a sun. Now, it has taken some sophisticated calculations just to determine proper trajectories (courses) of unmanned probes to the vicinity of planets in our solar system. You can imagine the double

checking that would have to be done in the planning of a trajectory to another planet in another solar system.

Speaking of trajectories and of the speed of light, we know that the spaceship isn't going to fire up its engines and attain the speed of light in seconds. Rather, there will have to be a gradual build up of speed until "cruise" is reached. Toward the end of the journey, the spaceship will have to be decelerated to a normal (let's be arbitrary) approach speed of 25,000 mph. Now what does this mean? for one thing, the trajectory will probably have to be in three segments: acceleration, cruise (speed of light), and deceleration. After all, at cruise speed the direction of flight will have to be straight—as we think of straight—because the higher the velocity attained by a body the greater the force the mass of the body exerts and the greater its resistance to change in direction. In short, no course corrections would be possible. Finally, another factor would have to be considered—that of "clean" space. At the speed of light (or even high suboptic speeds) the planners will have to be certain that the spaceship avoids the disaster of hitting even a pebble-sized meteoroid.

If our descendants of many years hence decide that a voyage (one-way) to another galaxy is in order, they will have to find a method of attaining supraoptic speeds. (This means above the speed of light.)

Recall that the diameter of our galaxy is 100,000 light years. The distance to the nearest galaxy, Andromeda, usually isn't stated in light years. When things get this "far out" they are spoken of in *Parsecs*, and one parsec is equal to 3.26 light years. To Andromeda, the distance is more than 500 kiloparsecs (one kiloparsec = 3,260 light years).

To travel such distances, man will have to exceed the speed of light. This, we admit, may or may not be possible. The point is somewhat controversial because it is now believed that the speed of light is the ultimate speed and even it cannot be reached by a "spaceship," much less exceeded. On the other hand, we would not want to say categorically that such feats are impossible because we must remember the many hurdles mankind has crossed just to begin exploration of the aerospace frontier. These hurdles were, in their time, impossibilities too.

# APPENDIX

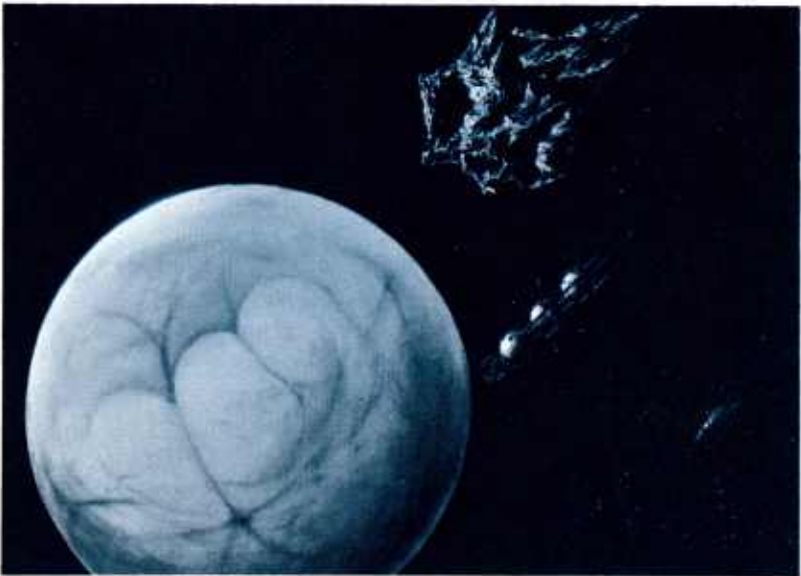

FIGURE 178 Space ship approaching Mars passing the moon, Phobos

GLOSSARY

## CHAPTER 1

- AERIAL**—Of or pertaining to operations in the air.
- AERODYNAMICS**—The art or science of flying through the air.
- AERONAUT**—The pilot or navigator of a balloon or dirigible.
- AEROSTAT**—A dirigible, balloon or any lighter-than-air aircraft.
- AILERON**—A movable (Up, down) hinged section placed on the trailing edge of airplane wings.
- AIRPLANE**—Any winged craft that is kept aloft by the forces of air acting upon its wings. (In this broadest sense, helicopters, gliders, autogyros, and winged missiles are included. However, the useage usually refers to the conventional fixed-wing, passenger-carrying craft.)
- ALTITUDE**—The height of an object above the earth's surface. (In aeronautics, the height of an object above sea level.)
- ATMOSPHERE**—The gaseous mass surrounding any planet or sun.
- DIHEDRAL**—The upward or downward slope of an airplane's wings in respect to the horizontal.
- DIRIGIBLE**—Any lighter-than-air aircraft that has its own motive power and a directional control system.
- ELEVATOR**—A control surface which is moved to make the tail portion of aircraft go either up or down.
- EMPENNAGE**—The assembly at the rear (tail) of an airplane; usually consists of horizontal and vertical stabilizers, and their associated control surfaces.
- ENGINE**—The propulsion unit of an aircraft or rocket.
- FUSELAGE**—The main structure of an airplane which houses or contains the crew, passengers, cargo, etc.
- LAUNCH**—To release or send forth, under its own power only, a rocket or airplane; to send or take a glider into the air.
- MOTOR**—Anything that produces or imparts motion (engine is the preferred term when speaking of aircraft power plants.)
- RUDDER**—A movable control surface that is attached to the vertical stabilizer or vertical fin.
- VERTICAL FIN**—A fin affixed vertically. (Term is used commonly with reference to either an airplane or airship.)
- VERTICAL STABILIZER**—(Same as vertical fin)
- WING**—An airfoil on either side of an airplane's fuselage, paired off by one on the other side, the two providing the principal lift for the airplane.

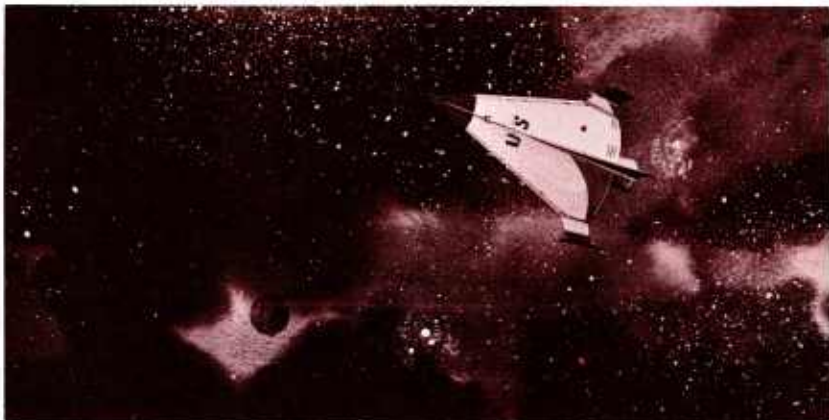

FIGURE 179

## CHAPTER 2

**AERODROME**—An area or place—on land or water—for the take-off and landing of aircraft. An airport or seaport. (Originally British.)

**BALLISTICS**—The science which deals with the motion and impact of projectiles, such as bullets, bombs, and rockets.

**BLITZKREIG**—(German for 'lightning war'): A smashing surprise attack by massed air and ground forces to destroy an enemy's defensive and offensive capabilities. The targets are the enemy's air power, munitions, communication lines, industry, and transport.

**FLAK**—Explosives or exploding shells fired from anti-aircraft cannon.

## CHAPTER 3

**AIRCRAFT**—Any craft designed to travel through the air, and regarded as a vehicle, with the ability to change direction by the movement of control surfaces.

**AIRWORTHY**—Fit and safe for flight.

**BEARING**—The relative direction taken by an aircraft, etc., with respect to true or magnetic north.

**COMPONENT**—A constituent part of a whole, as the wing of an airplane.

**CONTERMINOUS**—Enclosed within one common boundary.

**FATIGUE**—The weakening of metal or other material caused by microscopic changes in molecular structures resulting from vibration, bending or exposure.

**FLEET**—The entire lot of aircraft belonging to a single company.

**PROTOTYPE**—The first complete and working model of an aircraft series, class of weapons, etc.

**SMELT**—To melt or fuse so as to separate impurities from pure metal.

**TOLERANCE**—The allowable deviation from a standard.

#### CHAPTER 4

**ANALOGY**—Partial resemblance.

**CONCEPT**—A generalized idea.

**CONTOUR**—The outline of a figure, mass, etc.

**FLUTED**—Having rounded grooves.

**IMPERVIOUS**—Incapable of being passed through or penetrated.

**PREFLIGHT**—To check, test, and prepare an aircraft for use.

**SHUNT**—To move or turn to one side or away.

**SPAR**—Any principal structure in an airfoil (wing).

#### CHAPTER 5

**AFT**—Farthest back; behind.

**APERTURE**—An opening, or hole.

**BULKHEAD**—A partition or frame serving to divide, support or give shape to the fuselage of an airplane (or rocket).

**CORRODE**—To destroy gradually (as rust is a form of corrosion).

**GORE**—A triangular piece of cloth, metal, etc.

**SPHEROID**—A body that is almost but not quite a perfect sphere.

**TRANSDUCER**—A device that transmits power from one system to another system.

#### CHAPTER 6

**CRANKSHAFT**—The shaft in a reciprocating engine by which reciprocating motion is changed to rotary motion.

**HUMIDITY**—Moisture or dampness in the atmosphere.

**RADAR**—A system for beaming electromagnetic waves and then receiving the reflected waves to detect objects, measure distances, etc.

**RUNWAY**—A surface used for takeoff or landing of land-based airplanes.

**TAXIWAY**—A surface area designated for aircraft to taxi (move) to or from a runway.

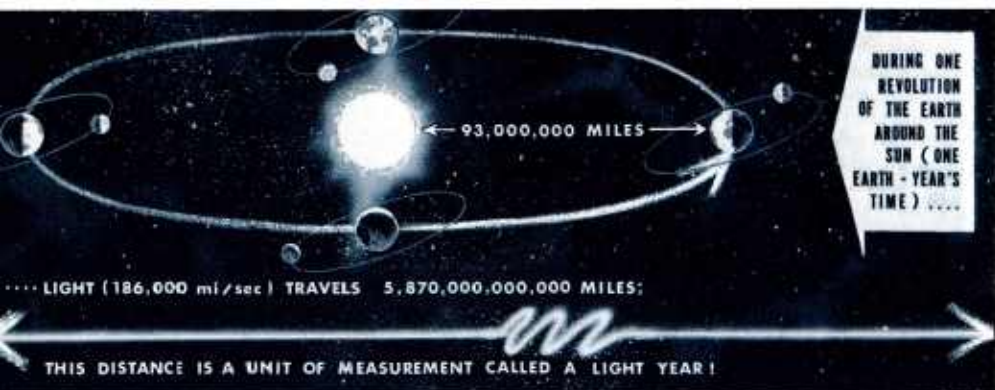

FIGURE 180 THE LIGHT YEAR

## CHAPTER 7

**AIRSPACE**—Space in the air above a particular surface of the earth.

**AUTONOMOUS**—Functioning independently; self-governing.

**CURRICULUM**—All the subjects that are required for a particular course of study; or all the courses of study in a school.

**MERGER**—The combination of several companies into one.

**OPTIMUM**—The best or most favorable degree, condition, amount, etc.

**TOPOGRAPHIC**—Pertaining to the surface features of the earth.

## CHAPTER 8

**ANTENNA**—The part of a radar or radio apparatus which radiates and/or receives electromagnetic waves.

**CYCLOTRON**—An apparatus that imparts high speeds to atomic particles by accelerating them magnetically.

**DRAG**—A resistant force that opposes the forward motion of flight.

**PLANET**—In our solar system, the nine major planets (Mercury, Venus, Earth, Mars, Jupiter, Saturn, Uranus, Neptune, and Pluto) and numerous minor planets (asteroids between the orbits of Mars and Jupiter) which reflect sunlight and revolve around the sun.

**PNEUMATICS**—The branch of physics which deals with the properties (such as pressure and density) of air or other gases.

**TRANSISTOR**—A minute electronic device which controls the flow of electric current without employing a vacuum.

## CHAPTER 9

**ALTRUISM**—The unselfish concern for the welfare of others.

**COLLEGE**—An institution of higher education that grants degrees (B.A., B.S.) at the completion of courses of study.

**UNIVERSITY**—An educational institution of the highest level, which typically consists of two or more colleges.

## CHAPTER 10

**CIRCUMSOLAR**—Around the sun.

**GALAXY**—A large grouping of stars, novae, solar systems, and gaseous matter which form a clearly definable body.

**JETTISON**—To throw something away, as from a ship or aerospace vehicle.

**UNIVERSE**—The totality of all things that exist.

**VELOCITY**—The rate of motion (speed) in a particular direction.



FIGURE 181 Intergalactic spacecraft passing Great Nebula in Orion

**BRAIN POWER IS AEROSPACE POWER**



THE ABOVE IS A 2-COLOR EXAMPLE OF THE FULL COLOR SLIDES AND FILM STRIPS

## **AEROSPACE EDUCATION**

NATIONAL HEADQUARTERS, CAP USAF



MAXWELL AIR FORCE BASE, ALFEMA

The Civil Air Patrol Aerospace Education Course curriculum is designed to be offered as a general elective on the high school level. Course orientation is one of general education with emphasis placed upon the impact of air and space vehicles upon our society and its importance for the future. Each of the seven textbooks included in the kit treat a selected area of the aerospace environment and is keyed to the learning of certain behavioral objectives. Each package of materials includes seven sets totaling more than 350 full color slides which are directly related to the seven textbooks, instructor guides and student workbooks.



## INTRODUCTION TO AEROSPACE

by Charles W. Conroy

History, growth and significance of aerospace affairs. The influence of aviation and space technology on human events. Aerospace manufacturing. Air transport. General aviation. Military aerospace power. Aerospace research. Education for the Aerospace Age. Aerospace careers.

Paperbound, illustrated, 56 pages, 1963



## THE CHALLENGE OF AEROSPACE POWER

By Charles W. Conroy

Introduction to aerospace power. Military aerospace power. The aerospace industry. Airline transportation. Airports and the community. Research and development. Education and aerospace power.

Paperbound, illustrated, 69 pages, 1968



## AIRCRAFT IN FLIGHT

By Robert E. McMinn

The atmosphere and theories of flight. Forces of flight. Stability and controls of aircraft. Design and structure. Aircraft instruments. High speed flight. Man in flight.

Paperbound, illustrated, 140 pages, 1970



## POWER FOR AIRCRAFT

By Robert E. McMinn

Aircraft powerplants, including reciprocating engines and their fuel, electrical, cooling, and lubrication systems; engine instruments and controls; propellers; jet engines and their accessories and subsystems; and powerplants of the future.

Paperbound, illustrated, 98 pages, 1969



## NAVIGATION AND THE WEATHER

By Charles W. Conroy

Measuring time, distance, and direction. Pilotage. Dead reckoning. Radio and electronic navigation. Celestial and inertial navigation. Weather. Air masses, fronts, and weather hazards.

Paperbound, illustrated, 124 pages, 1966



## AIRPORTS & AIRWAYS

By Mattison L. Story

Growth and development of airways. Charting airports and airways. Electronics. Why airports are necessary. Airways and air traffic management. The regulation of air traffic.

Paperbound, illustrated, 76 pages, 1962



## THE DAWNING SPACE AGE

By Charles W. Conroy and Harold E. Mehrens

History of rocketry. Guided missiles. Rocket engines and missile propulsion. Missile guidance systems. Space research. Flight into space.

Paperbound, illustrated, 248 pages.

### AEROSPACE EDUCATION COURSE SYLLABUS

The Aerospace Education Course Syllabus is a comprehensive and dynamic curriculum and resource guide which is designed for use with the seven textbooks contained in the kit.

### CATALOG

This catalog describes the inexpensive aerospace education materials available from National Headquarters Civil Air Patrol. These include textbooks, student workbooks, instructor guides, filmstrips, recordings, film strip study guides, programmed instruction exercises and self-study guides.



**AEROSPACE EDUCATION PERSONNEL**  
**National Headquarters, Civil Air Patrol**

**JOHN V. SORENSON**

Deputy Chief of Staff  
Aerospace Education and Cadet Program

Robert E. McMinn  
A/DCS, Aerospace Education  
and Cadet Program

Charles J. Wood  
Director, Audio-Visual  
Communications Division

Harold R. Bacon  
Director, Editorial and  
Curriculum Division

James O. Johnson  
Chief, Technical Education  
Methods and Devices

**REGIONAL DIRECTORS OF AEROSPACE EDUCATION**

**NORTH CENTRAL REGION**

(Ia,Ks,Mn,Mo,Ne,ND,SD)

Mr. Melvin A. Ziehl  
Dir, Aerospace Education  
USAF-CAP-RLO, NC Rgn, CAP  
P.O. Box 1509 A.M.F.  
Twin City Airport, Minn. 55111

**NORTHEAST REGION**

(Ct,Me,Ma,NH,NJ,NY,Pa,RI,Vt)

Dir, Aerospace Education  
USAF-CAP-RLO, NE Rgn, CAP  
32 Jericho Turnpike  
Mineola, NY 11501

**SOUTHWEST REGION**

(Az.,Ar,La,NM,Ok,Tx)

Mr. Arthur I. Martin  
Dir, Aerospace Education  
USAF-CAP-RLO, SW Rgn, CAP  
USNAS  
Dallas, Tex 75211

**MIDDLE EAST REGION**

(De,Md,DC,NC,SC,Va,WV)

Mr. William J. Reynolds  
Dir, Aerospace Education  
USAF-CAP-RLO, ME Rgn, CAP  
Stop A-90  
Andrews AFB, Md 20331

**ROCKY MOUNTAIN REGION**

(Co,Id,Mt,Ut,Wy)

Mr. John M. Ogle  
Dir, Aerospace Education  
USAF-CAP-RLO, RM Rgn, CAP  
Lowry AFB, Col 80230

**GREAT LAKES REGION**

(Il,In,Ky,Mi,Oh,Wi)

Mr. Wesley R. Kimball  
Dir, Aerospace Education  
USAF-CAP-RLO, GL Rgn, CAP  
ATTN: MCLGLR  
Wright-Patterson AFB, Ohio 45433

**PACIFIC REGION**

(Ak,Ca,Hi,Nv,Or,Wa)

Mr. L. D. "Pat" Cody  
Dir, Aerospace Education  
USAF-CAP-RLO, Pac Rgn, CAP  
Hamilton AFB, Cal 94935

**SOUTHEAST REGION**

(Al,Fl,Ga,PR,Tn,Ms)

Mr. Kenneth C. Perkins  
Dir, Aerospace Education  
USAF-CAP-RLO, SE Rgn, CAP  
P.O. Box 3117  
Dobbins AFB, Ga. 30060

