

CV95-1

ANNUAL REPORT

FOR

**AEROBIC BIOREMEDIATION OF A CONTAMINATED AQUIFER
PORT HUENEME, CALIFORNIA**

by

**Andrea Leeson, Richard L. Johnson, Paul C. Johnson, Christopher J. Perry
Robert E. Hincee, and David B. McWhorter**

Battelle
505 King Avenue
Columbus, Ohio 43210

31 January 1997

REPORT DOCUMENTATION PAGE			Form Approved OMB No. 074-0188	
Public reporting burden for this collection of information is estimated to average 1 hour per response, including the time for reviewing instructions, searching existing data sources, gathering and maintaining the data needed, and completing and reviewing this collection of information. Send comments regarding this burden estimate or any other aspect of this collection of information, including suggestions for reducing this burden to Washington Headquarters Services, Directorate for Information Operations and Reports, 1215 Jefferson Davis Highway, Suite 1204, Arlington, VA 22202-4302, and to the Office of Management and Budget, Paperwork Reduction Project (0704-0188), Washington, DC 20503				
1. AGENCY USE ONLY (Leave blank)		2. REPORT DATE	3. REPORT TYPE AND DATES COVERED	
		31 January 1997	Annual Report	
4. TITLE AND SUBTITLE			5. FUNDING NUMBERS	
Annual Report for Aerobic Bioremediation of a Contaminated Aquifer, Port Hueneme, California			N/A	
6. AUTHOR(S)				
Andrea Lesson, Richard L. Johnson, Paul C. Johnson, Christopher J. Perry, Rober E. Hinchee, David B. McWhorter				
7. PERFORMING ORGANIZATION NAME(S) AND ADDRESS(ES)			8. PERFORMING ORGANIZATION REPORT NUMBER	
Battelle 505 King Avenue Columbus, OH 43210			N/A	
9. SPONSORING / MONITORING AGENCY NAME(S) AND ADDRESS(ES)			10. SPONSORING / MONITORING AGENCY REPORT NUMBER	
SERDP 901 North Stuart St. Suite 303 Arlington, VA 22203			N/A	
11. SUPPLEMENTARY NOTES				
This project is funded by the Strategic Environmental Research and Development Program (SERDP). The United States Government has a royalty-free license throughout the world in all copyrightable material contained herein. All other rights are reserved by the copyright owner.				
12a. DISTRIBUTION / AVAILABILITY STATEMENT			12b. DISTRIBUTION CODE	
Approved for public release: distribution is unlimited.			A	
13. ABSTRACT (Maximum 200 Words)				
This report describes laboratory and field activities conducted to date on the air sparging technology. Laboratory studies are being conducted at Arizona State University and at the Oregon Graduate Institute. Field studies are being conducted at the Naval Exchange Gasoline Station, Port Hueneme, CA. This project is being conducted for the Environics Directorate of the Armstrong Laboratory, Tyndall Air Force Base Florida. This project involves the installation and operation of two air sparging systems in the field, and laboratory evaluation of parameters affecting air sparging.				
14. SUBJECT TERMS			15. NUMBER OF PAGES	
air sparging Tyndall AFB Port Hueneme				
SERDP SERDP Collection			16. PRICE CODE N/A	
17. SECURITY CLASSIFICATION OF REPORT		18. SECURITY CLASSIFICATION OF THIS PAGE	19. SECURITY CLASSIFICATION OF ABSTRACT	
unclass.		unclass.	unclass.	
			20. LIMITATION OF ABSTRACT	
			UL	

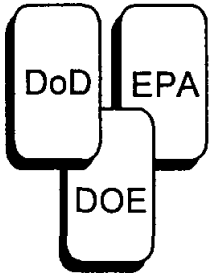

SERDP

Strategic Environmental Research
and Development Program

Improving Mission Readiness through
Environmental Research

ANNUAL REPORT

**Aerobic Bioremediation of a
Contaminated Aquifer**

31 January 1997

To

**Environics Directorate of the
Armstrong Laboratory**

TABLE OF CONTENTS

Contents	Page
LIST OF TABLES	iii
LIST OF FIGURES	iv
1.0 INTRODUCTION AND BACKGROUND	1
1.1 Program Overview	1
1.2 Technology Need	2
1.3 Technology Overview	3
1.4 Scope of Work and Objectives	4
2.0 SITE DESCRIPTION	4
2.1 Site Location and History	5
2.2 Geology	14
2.3 Hydrogeology	17
2.4 Contaminant Distribution	19
3.0 TECHNOLOGY DESCRIPTION	22
3.1 Principles of Air Sparging	22
3.2 Waste and Media Applicability	23
3.3 Status	23
4.0 PHYSICAL MODEL STUDIES	24
5.0 FIELD DEMONSTRATION	26
5.1 Site Characterization	26
5.1.1 Groundwater Survey	26
5.1.2 Collection and Analysis of Soil Samples	28
5.1.3 Collection and Analysis of Groundwater Samples	35
5.2 Installation Details	40
5.2.1 Construction Details of Sparge Wells	40
5.2.2 Construction Details of Multi-Level Samplers	44
5.2.3 Construction Details of Groundwater Monitoring Wells	44
5.2.4 Construction Details of Neutron Probe Access Tubes	44
5.2.5 Construction Details of Directional Soil Vapor Extraction Wells	49
5.3 Field Tests and Process Monitoring	49
5.3.1 System Operation	49
5.3.1.1 Site 1: Source Zone System	49
5.3.1.2 Site 2: Dissolved-Phase Zone System	50
5.3.2 Dissolved Oxygen Measurements	50
5.3.3 Chemical Contaminant Measurements	50
5.3.4 Geophysical Measurements	52
5.3.5 Tracer Measurements	56
5.3.5.1 Air Distribution Experiments	56

5.3.5.1.1 Pulsed SF ₆ Injection Study	56
5.3.5.1.2 Continuous SF ₆ Injection Study	58
5.3.5.2 Injected Air Recovery	62
6.0 SUMMARY	65
7.0 REFERENCES	67
APPENDIX A: RESULTS FROM TWO-DIMENSIONAL LABORATORY-SCALE PHYSICAL MODEL STUDIES: MASTER'S THESIS	A-1
APPENDIX B: LABORATORY ANALYTICAL REPORTS	B-1
APPENDIX C: SOIL BORING LOGS	C-1
APPENDIX D: SUMMARY OF FIELD ANALYSES OF CONTAMINANTS AND DISSOLVED OXYGEN	D-1
APPENDIX E: SUMMARY OF PULSED SF ₆ INJECTION STUDIES	D-1

LIST OF TABLES

Table 1. Contaminants of Concern	20
Table 2. Groundwater Survey Results for BTEX and TVHC	29
Table 3. Groundwater Survey Results for MTBE	31
Table 4. Soil Analyses from Site 1, Port Hueneme, CA Averaged by Depth	36
Table 5. Soil Analyses from Site 2, Port Hueneme, CA Averaged by Depth	37
Table 6. Vertical Distribution of Dissolved Hydrocarbons at Multi-Level Sampler MP3, Site 1, Port Hueneme Field Analyses	38
Table 7. Laboratory Groundwater Analyses from Site 1, Port Hueneme, CA	39

LIST OF FIGURES

Figure 1.	Regional Location Map	6
Figure 2.	Site Location Map for Naval Exchange Gasoline Station at Port Hueneme, California (PRC and Montgomery Watson, 1994a)	7
Figure 3.	Naval Exchange Gasoline Monitoring Well and Interim Corrective Action Treatment System Locations (PRC and Montgomery Watson, 1994a)	8
Figure 4.	Schematic Diagram Illustrating Areas Covered With Asphalt at the Naval Exchange Gasoline Station (PRC and JMM, 1991)	12
Figure 5.	Schematic Diagram Illustrating Location of Utility Lines at the Naval Exchange Gasoline Station (PRC and JMM, 1991)	13
Figure 6.	Location of Cross Section A-A' at the Naval Exchange Gasoline Station, Port Hueneme (PRC and JMM, 1991)	15
Figure 7.	Cross Section A-A' Showing Site Lithology and Depth to Groundwater at the Naval Exchange Gasoline Station, Port Hueneme (PRC and JMM, 1991)	16
Figure 8.	Water Table Contour Map in the Semiperched Aquifer at the Naval Exchange Gasoline Station	18
Figure 9.	Benzene Plume (1993) at the Naval Exchange Gasoline Station, Port Hueneme (NFESC, 1995)	21
Figure 10.	Schematic Diagram of the Two-Dimensional Laboratory-Scale Aquifer Physical Model	25
Figure 11.	General Locations for the Initial Groundwater Survey	27
Figure 12.	Locations of Groundwater Survey Points at Site 1, Port Hueneme, CA	32
Figure 13.	Locations of Groundwater Survey Points at Site 2, Port Hueneme, CA	33
Figure 14.	Locations of the Air Sparging Systems at the Naval Exchange Gas Station, Port Hueneme, CA	34
Figure 15.	Schematic Diagram Showing Locations of Installations at Site 1, Port Hueneme, CA	41
Figure 16.	Schematic Diagram Showing Locations of Installations at Site 2, Port Hueneme, CA	42
Figure 17.	Schematic Diagram Showing Cross Section of Sparge Wells	43
Figure 18.	Schematic Diagram Showing a Cross Section of a Single Sampling Point Within a Multi-Level Sampler	45
Figure 19.	Schematic Diagram Showing a Cross Section of a Typical Multi-Level Sampler	46
Figure 20.	Schematic Diagram Showing a Cross Section of a Typical Groundwater Monitoring Well	47
Figure 21.	Schematic Diagram Showing a Cross Section of a Typical Neutron Probe Access Tube	48
Figure 22.	Dissolved Oxygen Concentrations Averaged by Depth at Multi-Level Samplers Located 5, 10, 20, and 30 ft Radially from the Sparge Well: Pre- and Post-Air Sparging	51
Figure 23.	Benzene Concentration Averaged by Depth at Distances of 5, 10, 20, and 30 ft from the Sparge Well	53
Figure 24.	TPH Concentrations in System Off-Gas Pre- and Post-Air Sparging	54
Figure 25.	Air Saturation Data Estimated From Neutron Probe Measurements	55
Figure 26.	Air Saturation from Electrical Resistance Measurements	57

Figure 27.	Directional Soil Vapor Extraction Well Response to SF ₆ Pulse Injection at MP1-4.0'	59
Figure 28.	Directional Soil Vapor Extraction Well Response to SF ₆ Pulse Injection at MP4-4.0'	60
Figure 29.	Percent Saturation of SF ₆ in Groundwater Relative to Input Concentration	61
Figure 30.	Percent Saturation of Dissolved Oxygen Based on Equilibrium with the Atmosphere	63
Figure 31.	Recovery of Sparge Air in the Soil Vapor Extraction System (Measured as % Helium Recovered)	64
Figure 32.	Helium Concentration (%) at a Depth of 8 ft	66

ANNUAL REPORT
FOR
AEROBIC BIOREMEDIATION OF A CONTAMINATED AQUIFER

31 January 1997

This report describes laboratory and field activities conducted to date on the air sparging technology. Laboratory studies are being conducted at Arizona State University and at the Oregon Graduate Institute. Field studies are being conducted at the Naval Exchange Gasoline Station, Port Hueneme, CA. This project is being conducted for the Environics Directorate of the Armstrong Laboratory Tyndall Air Force Base (AFB) Florida. The project is funded by the Strategic Environmental Research Development Program (SERDP). This project involves the installation and operation of two air sparging systems in the field, and laboratory evaluation of parameters affecting air sparging.

1.0 INTRODUCTION AND BACKGROUND

This section introduces the Department of Defense/National Environmental Technology Demonstration Program (D/NETDP) and the air sparging technology. The introduction includes an overview of D/NETDP, a discussion of the general need for innovative technologies, a brief description of air sparging, and a presentation of the scope of work for the technology demonstration.

1.1 Program Overview

Port Hueneme, California is a National Test Location designated through SERDP. As a D/NETDP test site location, Port Hueneme has been selected for technology demonstrations sponsored by SERDP, other government agencies, and the private sector. The D/NETDP mission is to provide locations for comparative demonstration and evaluation of innovative technologies performing environmental characterization, cleanup, and monitoring. Candidate innovative technologies must have the potential to be more cost-effective or to achieve significantly reduced risks compared to currently available processes. The technologies also must be applicable to Installation

Restoration (IR) efforts at Department of Defense (DoD) facilities. The ultimate goal of D/NETDP is to accelerate the market availability of these new DoD-applicable technologies. This goal will be achieved through a series of demonstrations designed to evaluate the success and applicability of each innovative technology tested.

1.2 Technology Need

Historic handling practices and past spills and leaks have caused petroleum releases to the environment to occur at most industrial and government fuels-handling facilities. Petroleum distillate fuel hydrocarbons such as diesel fuel are generally biodegradable if naturally occurring microorganisms are provided an adequate supply of oxygen and basic nutrients. Natural biodegradation does occur and, at many sites, eventually may mineralize most fuel contamination. However, the process is dependent on natural oxygen diffusion rates and as a result frequently is too slow to prevent the spread of contamination. Such sites may require remediation of the contaminant source to protect sensitive aquifers. At these sites, an acceleration or enhancement of the natural biodegradation process may prove the most effective remediation.

When a fuel release occurs, the contaminants may be present in any or all of three phases in the geologic media: adsorbed to the soils in the vadose zone, floating on the water table in free-phase form, and/or dissolved in the groundwater. Of the three phases, dissolved petroleum contaminants in the groundwater are considered to be of greatest concern due to the risk of human exposure through drinking water. However, the liquid- and adsorbed-phase hydrocarbons act as feedstocks for groundwater contamination, so any remedial technology aimed at reducing groundwater contamination must address these contaminant sources.

In recent years, numerous in situ methods for remediating hydrocarbon-contaminated soils above the water table have been proposed and studied. Soil vapor extraction (Johnson et al., 1990) and bioventing (Hinchee et al., 1991) have emerged as popular choices due to the ease with which these systems can be installed and operated. Their application, unfortunately, is limited to the vadose zone, or to normally water-saturated zones that can be exposed to air flow by artificially depressing the groundwater table (usually through pumping).

Cost-effective and proven treatment processes for hydrocarbon-contaminated soils both within the capillary fringe and beneath the water table have yet to emerge. Historically, groundwater pump-and-treat systems have been used, but the relatively low solubilities of fuel-range hydrocarbons render

these systems effective only for containment purposes (Rixey et al., 1991). Another option is to depress the water table and then apply soil vapor extraction or bioventing (Johnson et al., 1990). Unfortunately, the costs associated with aboveground water treatment and discharge can be prohibitive. A number of innovative saturated zone treatment approaches currently are under development, including chemically enhanced pump-and-treat systems (Rixey et al., 1991), engineered bioremediation schemes (Salanitro, 1993), and in situ air sparging (Ardito and Billings, 1990). Of these, in situ air sparging is gaining broad appeal because, like soil vapor extraction and bioventing, it is relatively simple to implement and capital costs are modest (Johnson et al., 1993).

1.3 Technology Overview

Air sparging is the process of injecting clean air directly into an aquifer for remediation of contaminated groundwater. In situ air sparging remediates groundwater through a combination of volatilization and enhanced biodegradation. The induced air transport through the groundwater removes the more-volatile and less-soluble contaminants by physical stripping. Increased biological activity is stimulated by increased oxygen availability. Air sparging is being implemented by a number of practitioners; however, in a review of the state of the practice, Johnson et al. (1993) conclude that the limited data available to date have been insufficient to address key questions such as:

- What is the degree of hydrocarbon remediation that can be achieved by in situ air sparging?
- How is the rate and extent of treatment influenced by heterogeneities and contaminant type?
- What are the role and significance of biodegradation/oxygenation, volatilization, and mixing processes?
- Can the data collected from short-term pilot tests be used to assess feasibility and design effective systems?
- How do changes in design parameters and operating conditions influence effectiveness?
- What design method should be followed?

1.4 Scope of Work and Objectives

The scope of work for this project includes pre-demonstration site characterization, implementation of the technology demonstration, demobilization from the site, and disposal of generated wastes.

The three major tasks in completing the scope of work are listed below:

- Task 1 involves conducting laboratory studies using intermediate- and large-scale physical model studies.
- Task 2 involves field testing of two systems installed in the same contaminant plume, with one system installed in the dissolved phase and one system installed in the residual phase. This task involves field monitoring and sample collection and analyses at the field test site to quantify in situ air flow and achieve a closed mass balance for hydrocarbon contaminants, oxygen, and air flow.
- Task 3 will involve development of a protocol for evaluating the application of air sparging to sites with different contaminant or matrix properties that will include development of field data interpretation practices and screening-level estimates of performance.

The following four objectives were defined for this project:

- Determine the potential effectiveness of air sparging for remediation at hydrocarbon fuel release sites.
- Determine how to best monitor system performance.
- Determine the impact of varying the design and operating conditions.
- Obtain data necessary to determine the demonstration cost and the cost to scale up the technology.

2.0 SITE DESCRIPTION

This section presents information on the test site located at Port Hueneme. The information presented here includes the current understanding of site geology, hydrogeology, and contaminant

distribution at the Naval Exchange Gasoline Station. These parameters will be addressed during the implementation of the air sparging technology presented in Section 3.0.

2.1 Site Location and History

As illustrated in Figure 1, Port Hueneme is located in Ventura County, California, approximately 40 miles northwest of Los Angeles. Established in 1942 to meet World War II military requirements, Port Hueneme consists of 1,667 acres of coastal land situated approximately 5 miles northwest of the Santa Monica Mountains. The facility contains some 750 buildings and supports a work force of more than 10,000 individuals (SCS and Landau Associates, 1985).

The Naval Exchange Gasoline Station is located within the east-central portion of the base at the southeast corner of 23rd Avenue and Dodson Street (Figures 2 and 3). The site serves as a retail outlet for gasoline and automotive service for civilian and military personnel working at the base. Gasoline is the only type of contamination reported to have been released from this site.

In December 1984, the Public Works Department at the base discovered free product (gasoline) during the first investigation that was conducted on the area around the Naval Exchange Gasoline Station. In March 1985, it was determined that two of the gas station's fuel delivery lines that ran from the underground storage tanks (USTs) to the gasoline dispensers were leaking. These leaking fuel lines are thought to be the single source of contamination. Inventory records indicate that an estimated combined total of 10,800 gallons of leaded regular and premium unleaded gasoline (containing methyl tertiary butyl ether [MTBE] and 1,2-dichloroethane additives) was released to the subsurface between September 1984 and March 1985. It is not known how much was released prior to that time interval. New tanks were installed shortly after the leak was detected. In December 1992, eight additional tanks were installed and the soils around both the original and the new tank pits were removed. Limited free-phase product was detected during that removal action. Initial subsurface investigations began in 1985. The Final Corrective Action Plan was published in June 1994.

Between 1985 and 1994, six major studies were performed to attain a comprehensive understanding of the nature and extent of contamination and to develop a feasible approach to remediation. These studies and their major components and findings are summarized in the Final Corrective Action Plan (PRC Environmental Management, Inc. [PRC] and Montgomery Watson, 1994a) as cited below:

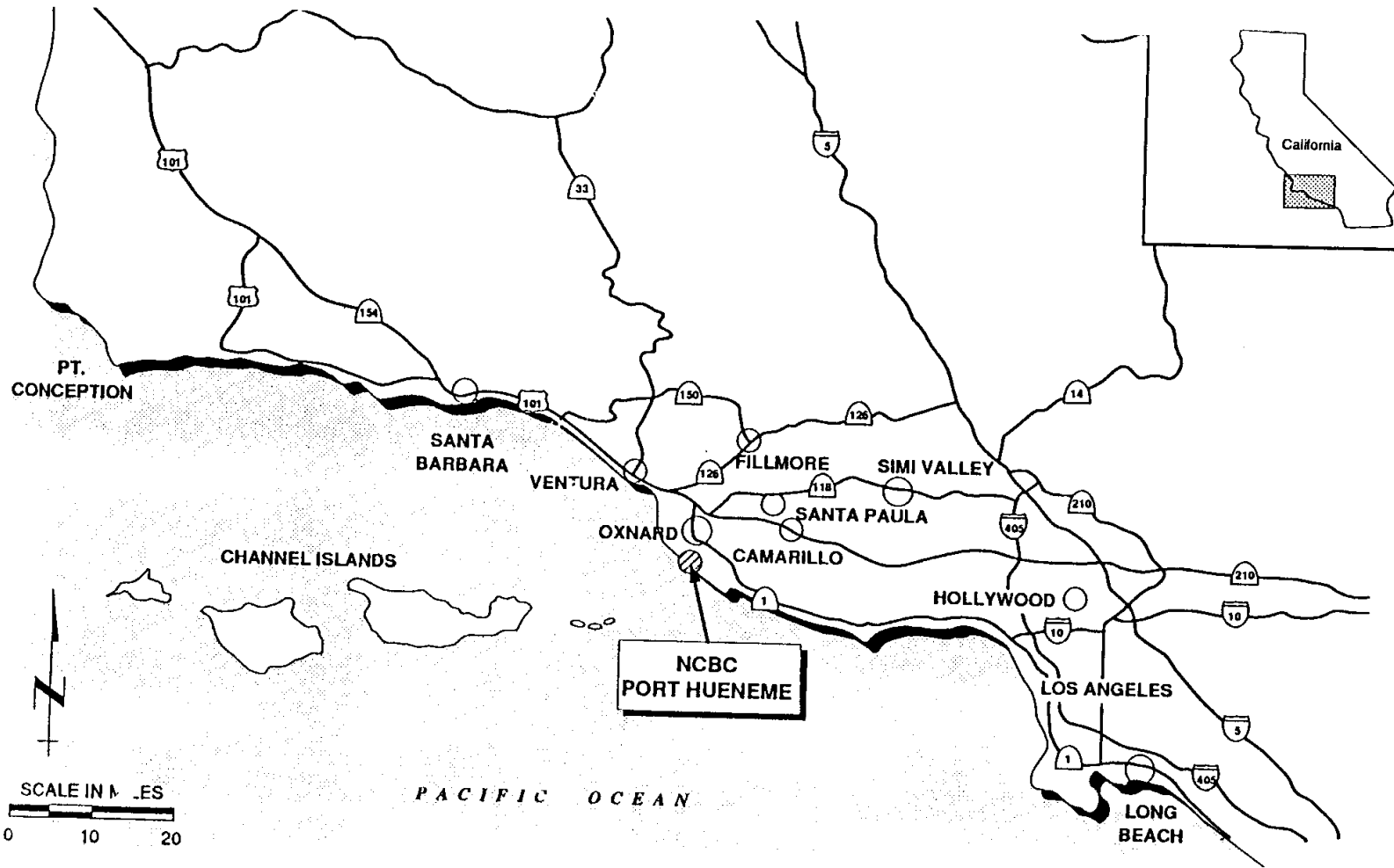

Figure 1. Regional Location Map

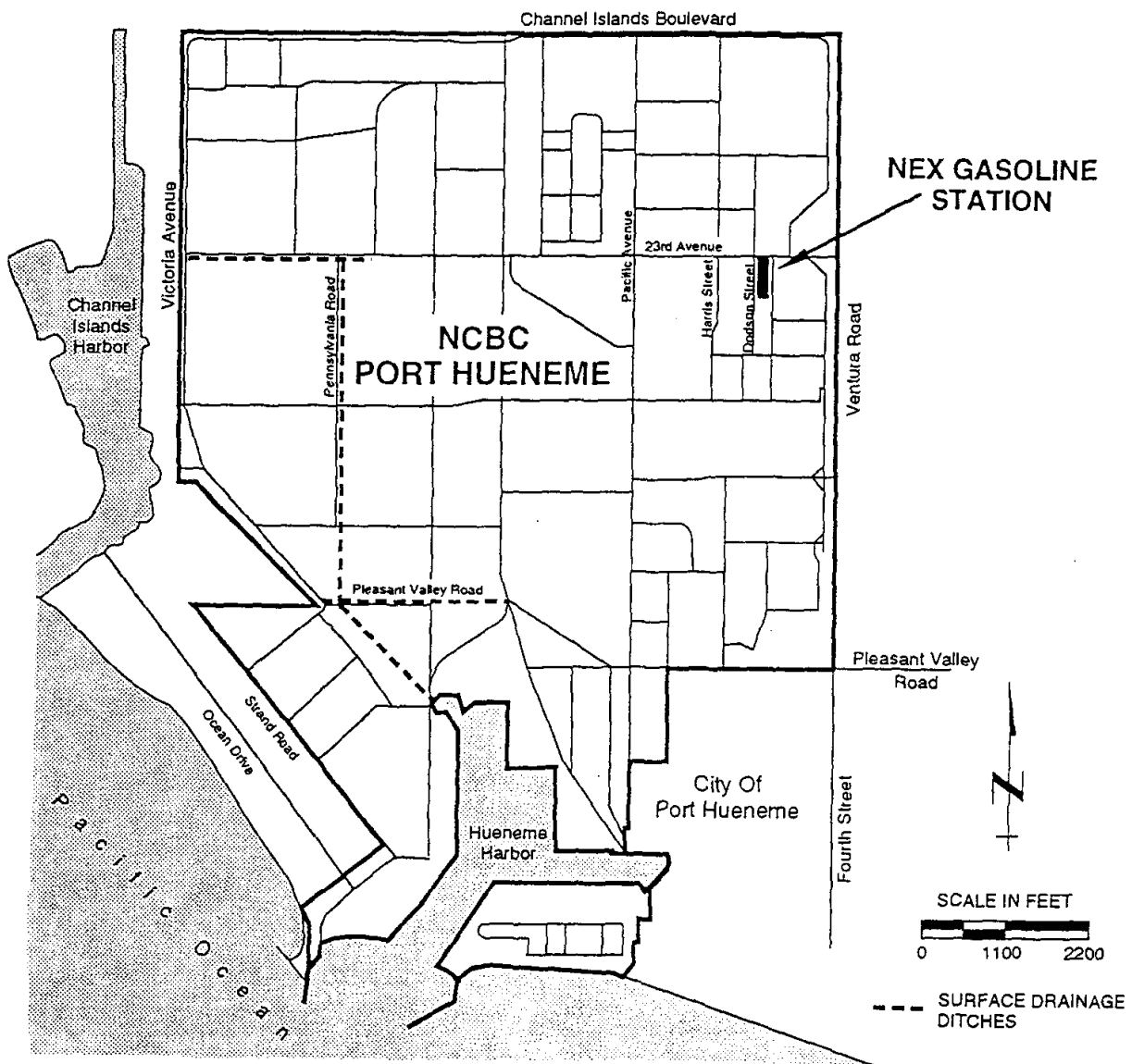

Figure 2. Site Location Map for Naval Exchange Gasoline Station at Port Hueneme, California (PRC and Montgomery Watson, 1994a)

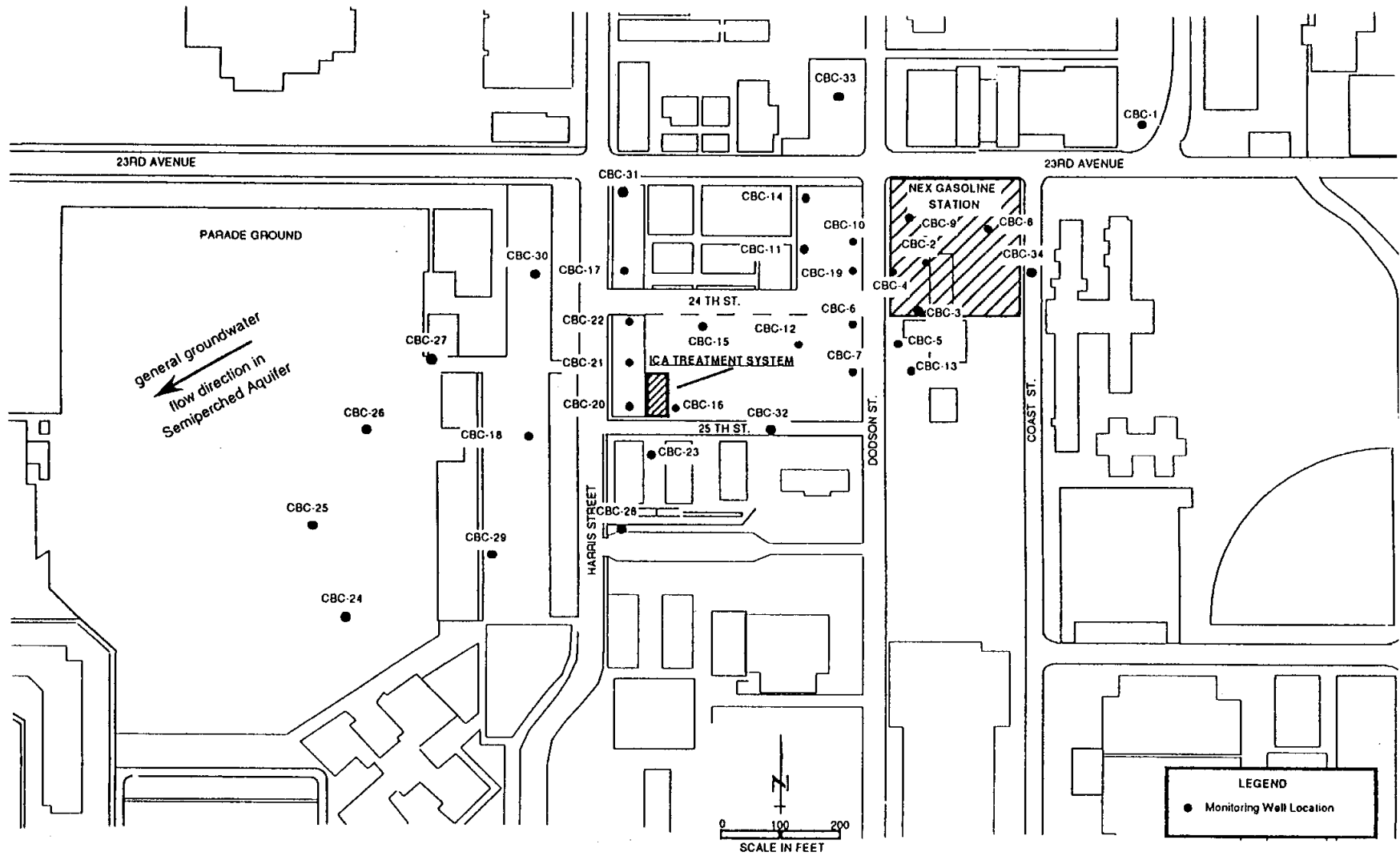

Figure 3. Naval Exchange Gasoline Monitoring Well and Interim Corrective Action Treatment System Locations (PRC and Montgomery Watson, 1994a)

1. Initial Assessment Study of Naval Construction Battalion Center (CBC) (SCS and Landau Associates, 1985)
 - Background information regarding site stratigraphy, hydrogeology, and locations of existing and abandoned water-supply wells was assembled.
2. Step I — Spill Study and Verification (WESTEC Services, Inc. [WESTEC], 1986)
 - Seven monitoring wells, CBC-1 through CBC-7, were installed as a preliminary effort to determine the extent of fuel contamination.
 - Benzene, toluene, ethylbenzene, and xylenes (BTEX) constituents were detected in groundwater samples collected from all seven wells.
 - Floating, free-phase product was found in wells CBC-2 through CBC-6.
3. Step II — Characterization Study (WESTEC and R.L. Stollar and Associates [Stollar], 1988)
 - Seven additional wells, CBC-8 through CBC-14, were installed in an effort to “chase” the plume farther downgradient.
 - Hydrocarbon compounds were detected in the soil and groundwater in samples from all seven new well locations. The lateral extent of the dissolved-phase groundwater plume was not defined.
 - The concentrations of hydrocarbons in the soil were highest near or within the capillary fringe and near the spill zone.
 - Free-phase product was discovered in well CBC-10 at a thickness of 0.9 ft.
 - The concentrations of dissolved-phase hydrocarbons in groundwater samples were higher than the concentrations presented in the Step I study. Both studies sampled water from wells containing free-phase product.
 - Aquifer tests were conducted at CBC-12, including a step-drawdown test and a 14-hour pump test.
 - The study recommended: (1) immediate free-product recovery; (2) design of a groundwater treatment system; (3) a feasibility study for soil remediation; and (4) installation of downgradient monitoring wells.
4. Step III — Feasibility Study (WESTEC and James M. Montgomery, Inc. [JMM], 1987)
 - The study reviewed existing remedial technologies and data available from the Step I characterization study.
 - The study recommended site remediation by groundwater removal, ex situ groundwater treatment, and soil vapor extraction. The study specified the use of

wells or a trench recovery system to extract groundwater from the semiperched aquifer at the rate of 30 to 60 gpm. The recommended groundwater treatment was oil/water separation followed by granular activated carbon filtration.

5. Predesign Studies (ERC Environmental and Energy Services Co. [ERC], 1989)

- The study was conducted to delineate the extent of subsurface hydrocarbons and review corrective action alternatives.
- A survey of subsurface utilities was conducted at the site. Sanitary sewer lines, some of which are installed at a depth of approximately 8.5 ft, appeared to influence groundwater and free-product migration.
- A soil gas survey roughly delineated the extent of the dissolved hydrocarbon plume. The extent of the plume was larger than had been assumed by earlier studies. The general shape of the plume, as defined in this study, was confirmed by subsequent investigations.
- Monitoring wells CBC-15 through CBC-19 were installed and CBC-1 was abandoned and reinstalled.
- Extraction wells CBC-20 through CBC-23 were installed for interim corrective action and groundwater samples were collected from all monitoring wells.
- A groundwater treatability study was conducted.
- A 48-hour pump test was performed at CBC-19. The pump test data provided estimates of aquifer parameters for use in numerical modeling.
- A numerical groundwater model evaluated the effectiveness of various groundwater extraction and reinjection scenarios on containment and remediation of the free-phase and dissolved-phase plumes.
- The study recommended that interim corrective action include dual groundwater/free-product extraction from wells CBC-18, -21, -22, and -23 and groundwater treatment by air stripping.
- The study recommended that final corrective action include a total of seven extraction wells and five reinjection wells. Three large-diameter extraction wells were to be pumped at 25 gpm and four smaller wells, CBC-18, -20, -21, and -22, were to be pumped at 10 gpm each. The groundwater was to be treated and reinjected upgradient of the dissolved-phase plume through an array of five new wells.

6. Interim Corrective Action Investigation (PRC and JMM, 1991; 1992; PRC and Montgomery Watson, 1994a; 1994b)

- A soil gas survey was completed in September 1991 to delineate the extent of the detectable groundwater plume and to provide guidance for the placement of the

monitoring wells. The soil gas survey indicated that natural biodegradation of hydrocarbons was occurring in the subsurface.

- Wells CBC-24 through CBC-34 and new well CBC-1 were installed in September and October 1991.
- From November 1991 through April 1992, free-phase product was recovered by operating a dual-pump skimming system in well CBC-15 and by periodically hand-bailing the monitoring wells.
- A National Pollutant Discharge Elimination System (NPDES) permit for the release of treated water from the treatment system was issued by the Regional Water Quality Control Board (RWQCB) in April 1992.
- Periodic groundwater monitoring was conducted and reported from October 1991 through January 1994.
- The treatment system was installed then tested, operated, and modified from February 1992 through March 1994.
- In February 1993, a sequestering agent study was conducted to improve the performance of the treatment system by reducing precipitate formation. The system became fully operational after the sequestering agent system was implemented.

As depicted in Figure 4, land around the Naval Exchange Gasoline Station is predominantly covered with asphalt or is occupied by buildings. The covered areas include the Naval Exchange Gasoline Station, parking lots directly west and southwest of the gas station, various streets surrounding the gas station, and the parking lot and parade grounds located west of Harris Street. The large amount of asphalt and concrete covering the site may form a cap that inhibits or controls soil-gas migration (PRC and JMM, 1991).

A large number of utility lines traverse the areas around the Naval Exchange Gasoline Station, including the area containing the USTs and the product delivery lines. Utilities that are present include electrical power, natural gas, water, sanitary sewer, and storm drains. Figure 5 is a map of all utility lines known to be present in the study area. The depths that the trenches containing these lines were dug and backfilled vary according to line type. Depths are known or estimated to range from 3 to 9.5 ft below ground surface (bgs).

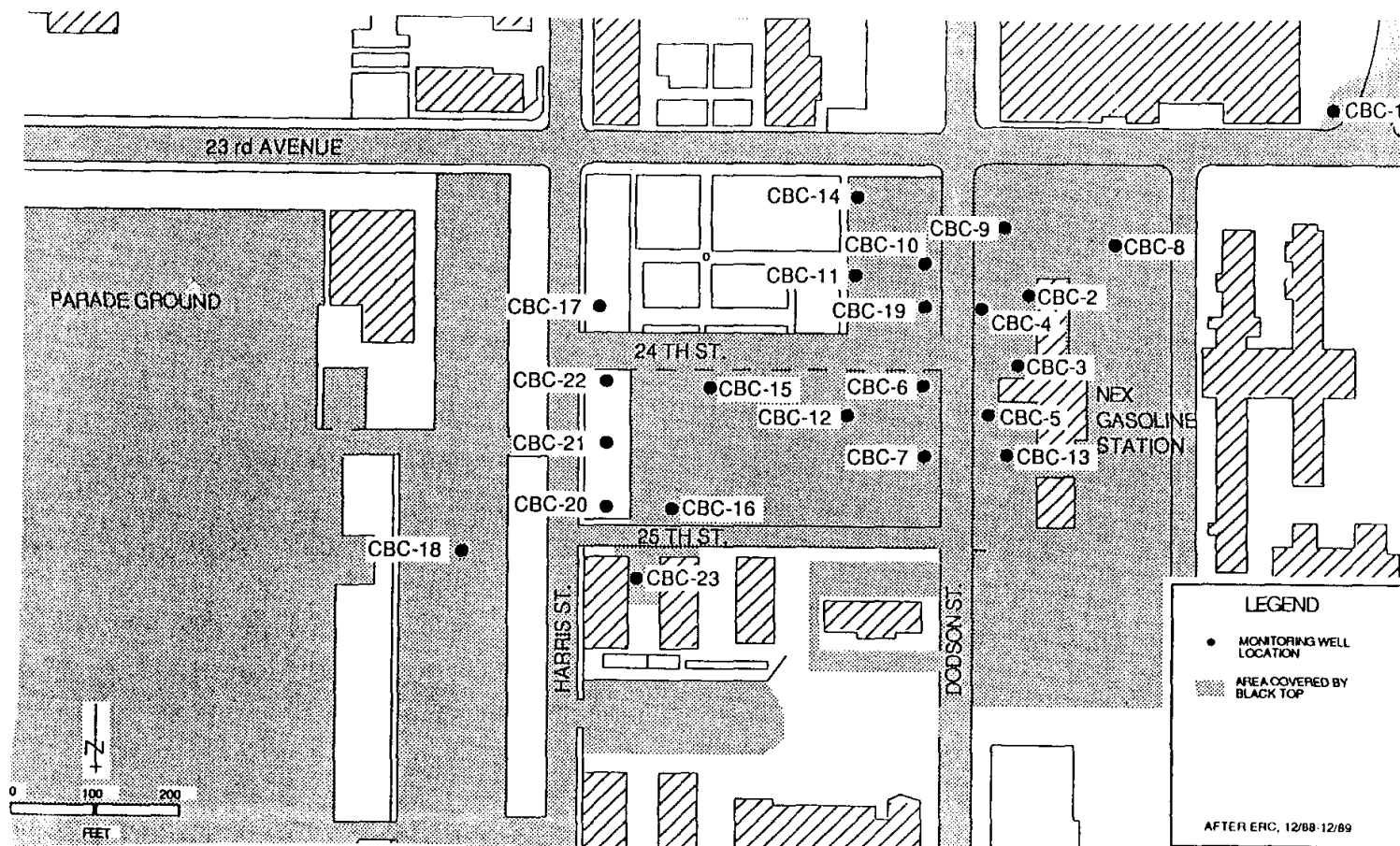

Figure 4. Schematic Diagram Illustrating Areas Covered With Asphalt at the Naval Exchange Gasoline Station (PRC and JMM, 1991)

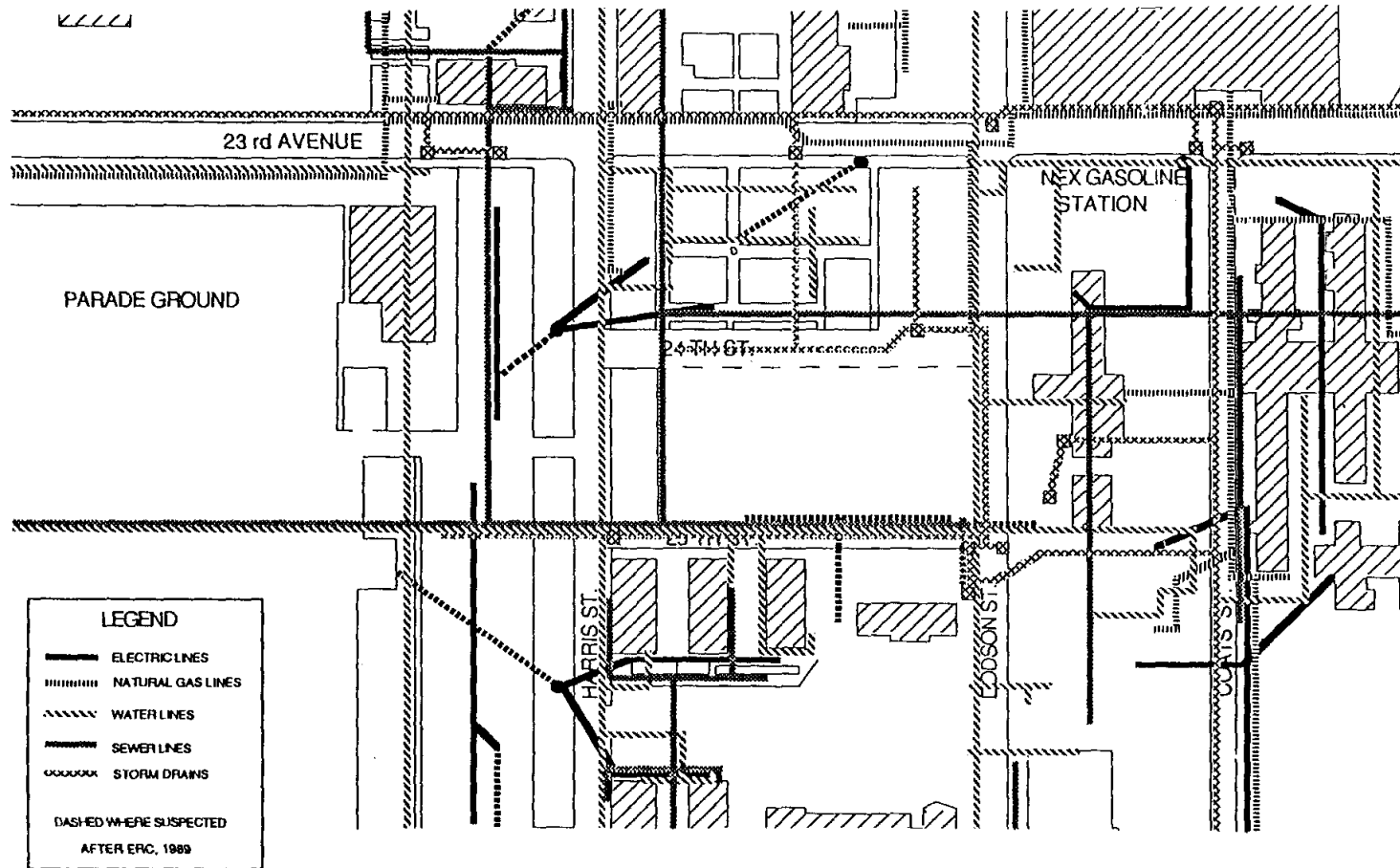

Figure 5. Schematic Diagram Illustrating Location of Utility Lines at the Naval Exchange Gasoline Station (PRC and JMM, 1991)

2.2 Geology

The near-surface geology in the vicinity of Port Hueneme was investigated during the Initial Assessment Study (SCS and Landau Associates, 1985), the Site Investigation (ERC, 1989), the Spill Study (WESTEC and Stollar, 1988) and the Predesign Study (ERC, 1989). In general, these studies indicate that Port Hueneme, situated on the Oxnard Plain, is underlain by unconsolidated sands, silts, and clays, with minor amounts of gravel and fill (PRC and JMM, 1991). These sediments are of fluvial-deltaic origin.

The near-surface sediment lithology at the Naval Exchange Gasoline Station conforms with the framework of the base's general geology. Based on borehole cuttings, the unconsolidated deposits are characterized into three units. The three units consist of an upper fine-grained silty sand unit, encountered from ground surface to a depth of between 3 and 6 ft bgs; an intermediate fine- to coarse-grained sand unit, encountered from the base of the silty sand unit to a depth of approximately 24 ft bgs; and an underlying clay unit consisting of a gray sandy or silty clay, encountered at about 25 ft bgs (PRC and JMM, 1991). Figures 6 and 7 show Cross Section A-A' and its orientation at the site.

Based on its composition, location, thickness, and site history, the uppermost, fine-grained silty sand unit has been interpreted by ERC (1989) to be fill material dredged from the Channel Island Harbor and Port Hueneme Harbor, but that interpretation has not been confirmed. Some investigators have postulated that the silty unit acts as a confining layer to the semiperched aquifer, which may be the case in some portions of the site. However, in the area containing the plume, the aquifer appears to be unconfined. The hydraulic heads displayed on the cross section in Figure 7 seem to confirm this, given that they are well below the contact between the uppermost silty unit and the underlying sandy unit.

During the execution of the various investigations cited in Section 2.1, a total of 65 soil gas probes and 34 groundwater monitoring wells were installed at the site. All of the boreholes and completed monitoring wells have been drilled to evaluate the semiperched aquifer to depths of about 25 ft bgs. This uppermost aquifer and the lithology beneath the site are depicted on Figure 7.

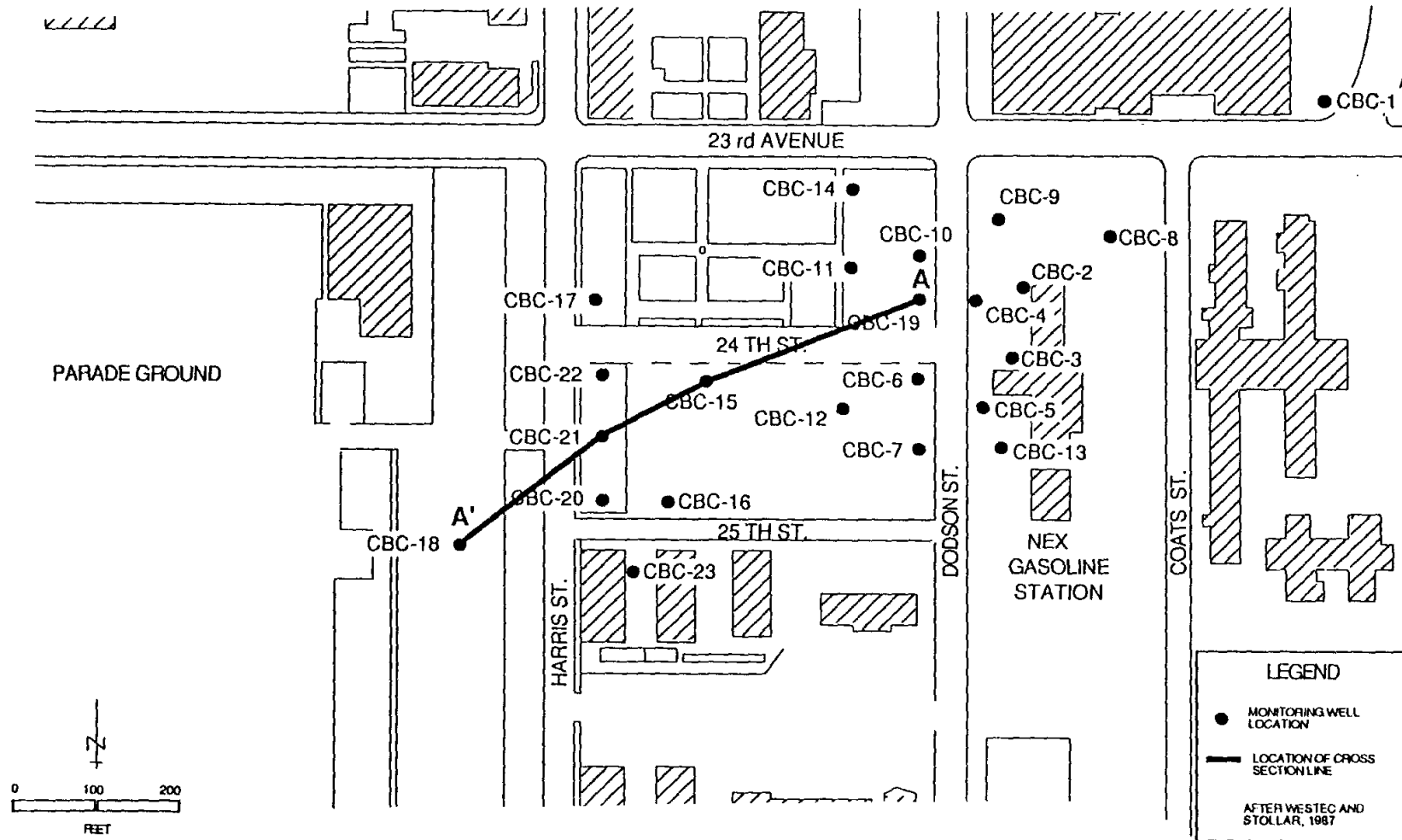

Figure 6. Location of Cross Section A-A' at the Naval Exchange Gasoline Station, Port Hueneme (PRC and JMM, 1991)

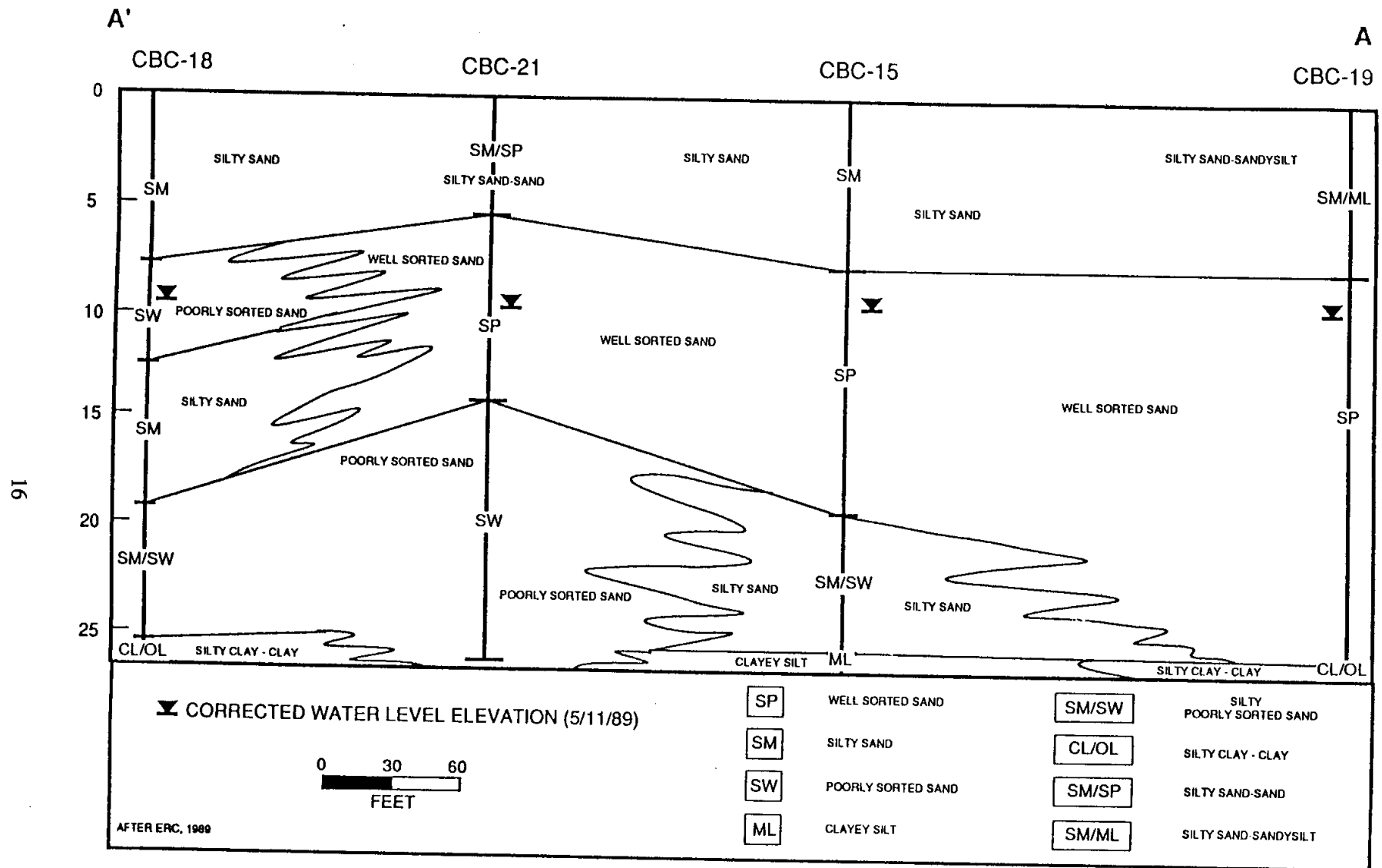

Figure 7. Cross Section A-A' Showing Site Lithology and Depth to Groundwater at the Naval Exchange Gasoline Station, Port Hueneme (PRC and JMM, 1991)

2.3 Hydrogeology

The semiperched aquifer has been investigated, tested, and modeled during several studies at the site (PRC and JMM, 1991; ERC, 1989). The semiperched aquifer consists of coarse to fine sands within a generally fining-upward sequence (PRC and JMM, 1991). The water table in this aquifer is contained within either the upper silty sand unit or the underlying fine- to coarse-grained sand unit (SCS and Landau Associates, 1985; ERC, 1989). At the Naval Exchange Gasoline Station, the semiperched aquifer has a lithologic content similar to that observed over most of the base. The lithology consists of silty sands and sandy silts in the upper 5 to 8 ft and overlies well-sorted and poorly sorted sands that generally extend to approximately 25 ft bgs. A clay cap unit underlies the sand unit. The clay cap is laterally extensive across the site as well as the rest of the base.

The saturated thickness of the semiperched aquifer is estimated to be about 15 ft thick from the water table to the top of the underlying clay cap. The depth to groundwater in the semiperched aquifer from ground surface is about 8 to 9 ft. As illustrated in Figure 8, the groundwater flow direction is generally to the southwest. The gradient is approximately 0.0029 ft per ft between monitoring wells CBC-1 and CBC-7 (WESTEC and Stollar, 1988). Geologic samples collected from the various borings that have been drilled at the site have been visually logged by field geologists. These descriptions and the cross sections constructed using these logs indicate that the site is not strongly interbedded. Characterization indicates that the semiperched aquifer is predominantly sand. The sand that comprises the aquifer is well sorted in some areas and is more poorly sorted in others. However, it is not known to contain layered zones of fine-grained sediment.

Several aquifer pump tests have been conducted to evaluate the hydraulic characteristics of the semiperched aquifer. Transmissivities in the vicinity of monitoring well CBC-19 range between approximately 10,000 and 44,000 gallons per day per ft (gpd/ft) (WESTEC and Stollar, 1988; ERC, 1989). Because the overlying silty sands are considered to be semiconfining at this particular location, the specific yield of the semiperched aquifer was not calculated. Instead, equations that are applicable to confined conditions were utilized and a storage coefficient was generated. The range of storativity values was found to be between 0.001 and 0.92. The storativity value used to model the pump test exercises was 0.05.

Additional aquifer tests done by WESTEC and Stollar (1988) arrived at transmissivity values ranging from 286 to 45,000 gpd/ft. Hydraulic conductivity values were estimated to range from 1,267 to 3,000 gpd/ft². The groundwater flow velocity was estimated to range from 694 to 1,643 ft

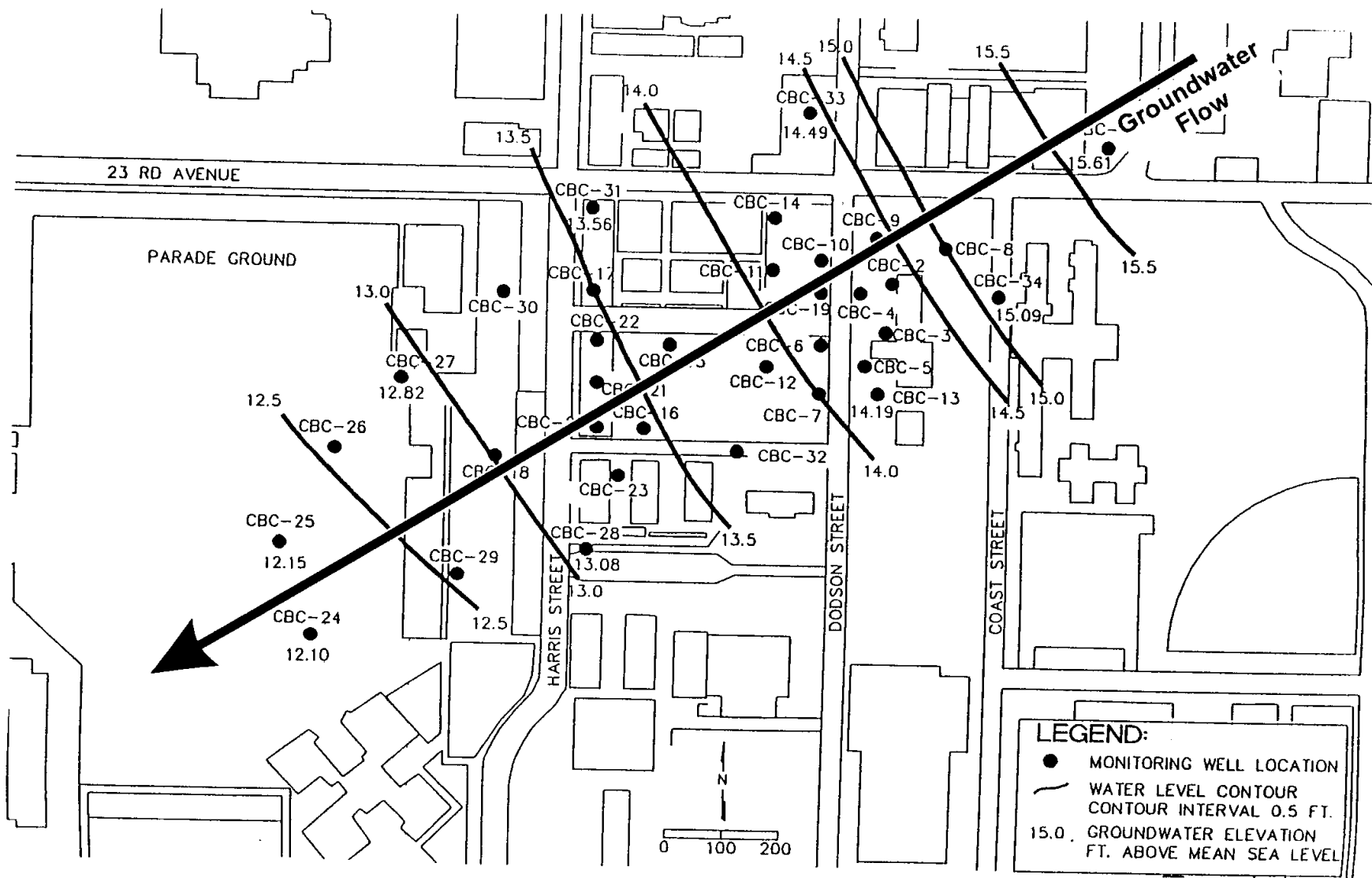

Figure 8. Water Table Contour Map in the Semiperched Aquifer at the Naval Exchange Gasoline Station

per year, based on a porosity of 30%. Estimates for free-product migration have been determined to be 0.9 ft/day.

The semiperched aquifer is brackish to saline. Total dissolved solids have been measured at 1,212 mg/L. The aquifer also has a high iron content (15 mg/L) and manganese content (17 mg/L), which may be indicative of reducing conditions induced by biologic degradation of the fuel. The aquifer also has elevated nitrite concentration due to irrigation practices in the rural portions of the Oxnard Plain. Groundwater movement within the semiperched aquifer is influenced by tidal fluctuations over some portions of the base, but not in the northeast quadrant where the Naval Exchange Gasoline Station is located. Discharge from the semiperched aquifer is to the drainage canals, harbors, and beaches on and around the base.

A 50-acre plot of the semiperched aquifer at the site was modeled to determine the best alternatives for hydraulic control of contamination. The Prickett Lonquist Aquifer Simulation Model (PLASM) was utilized during this effort. The model incorporated the values of hydraulic head, conductivity, and storativity presented above. No-flow boundaries were set at the base of the 25-ft-deep aquifer to represent the impermeable clay "cap" that underlies the site. No-flow boundaries were also set to the northwest and southeast, parallel to the historically observed orientation of the aquifer's hydraulic gradient. A constant head boundary was set on the upgradient end.

The model was calibrated and verified to a 48-hour aquifer pump test that was conducted in March 1989. There was good agreement. The model indicated that 80 gpm groundwater withdrawal from a line sink or series of wells in the vicinity of Harris Street and 25th Avenue would effectively capture dissolved contaminants 400 ft downgradient. This pumping configuration also would control the upgradient plume (Kram and Edkins, 1993).

2.4 Contaminant Distribution

The principal contaminants of concern at the Naval Exchange Gasoline Station are listed in Table 1. These contaminants were identified by the Naval Facilities Engineering Services Center as being present in the soil and groundwater. The dissolved constituents have moved down-gradient (southwestward) in groundwater and have formed a plume that was delineated and monitored during these studies. Soil gas surveys have defined the extent of the vapor plume for concentrations greater than or equal to 1 mg/L total hydrocarbons. The highest vapor-phase reading was 2,200 mg/L total hydrocarbons near well CBC-10 in January 1989.

Table 1. Contaminants of Concern

Matrix	Contaminant	Highest Concentration Detected
Soil (mg/kg)	Benzene	2.5
	Toluene	54
	Ethylbenzene	110
	Xylenes	100
Groundwater (mg/L)	Benzene	39
	Toluene	56
	Ethylbenzene	5.9
	Xylenes	35
	MTBE	10

Over time, various remedial actions and natural processes have impacted the geometry and concentration of the plume. These actions and processes include (1) the pumping and bailing of free product from various monitoring wells, (2) the natural advection and dispersion of dissolved contaminants as groundwater has naturally flowed southwestward across the site, (3) reduction of contaminant concentrations by extraction (pumpage) and treatment during implementation of the Interim Corrective Action Program, (4) demonstration of the UVB technology, and (5) natural attenuation due to biodegradation. Figure 9 illustrates the benzene plume distribution in 1993.

From October 1990 to May 1991, approximately 470 gallons of gasoline and 230,000 gallons of water were removed from wells 15, 17, 19, and 20 by a combination of hand bailing, skimmer pumping, and dual-pump extraction. Most of the product recovered was from well 19, which is near the central source area of the plume. This well proved to be an efficient gravity-flow collector for liquid product.

In 1995, a pilot-scale study was conducted at the site which evaluated a multiphase treatment called the Spray Aeration Vacuum Extraction System. It has the capability of treating groundwater at a rate of 10 gpm. During this pilot study, well CBC-19 was utilized for fluid extraction. The average soil vapor permeability was determined to be 220 darcys (calculated using method of Johnson

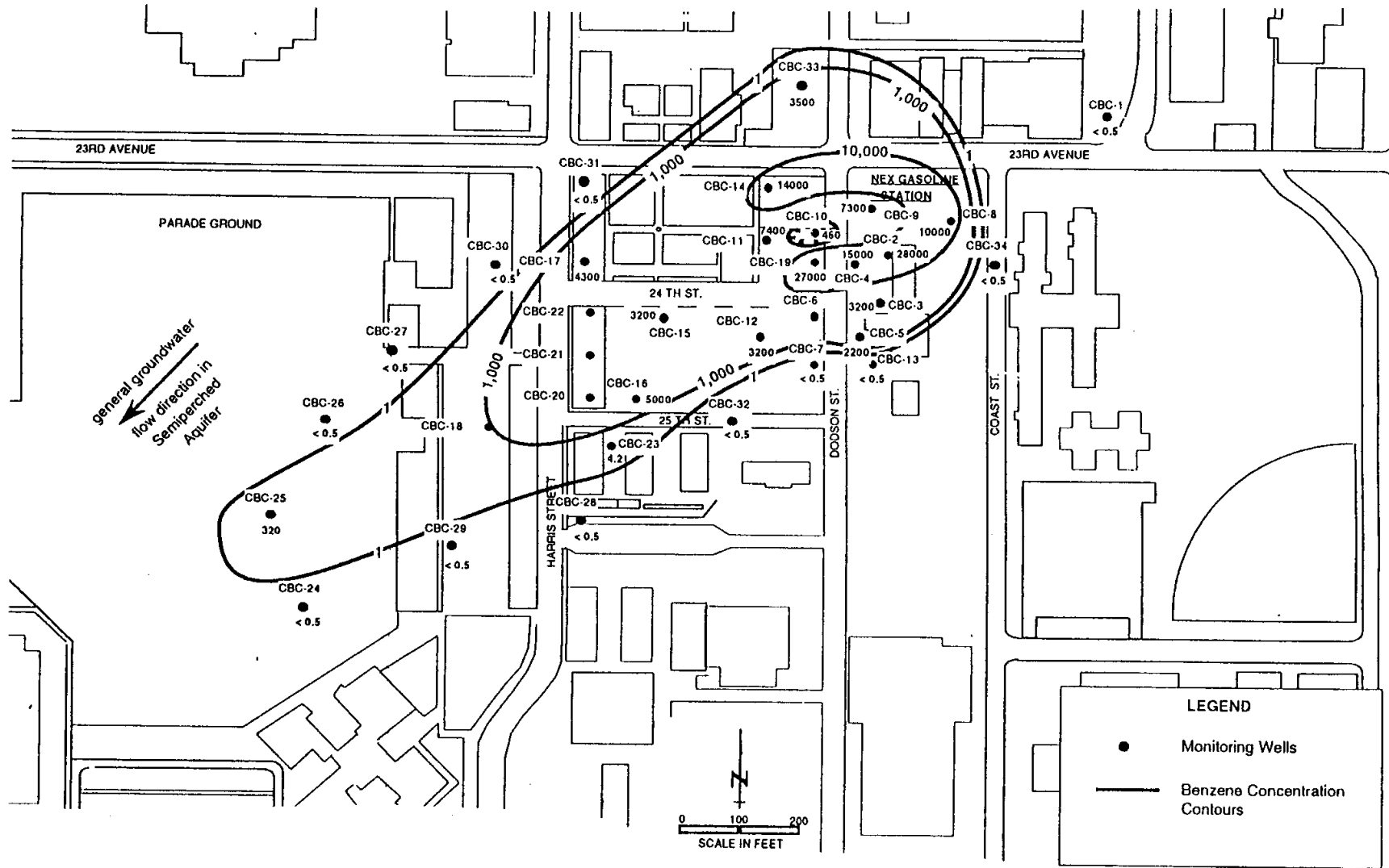

Figure 9. Benzene Plume (1993) at the Naval Exchange Gasoline Station, Port Hueneme (NFESC, 1995)

et al., 1990). A 90-ft radius of influence was observed. At influent groundwater flow rates ranging from 2 to 7.8 gpm, the system removed 85 to 98% of BTEX and 71 to 92% of total petroleum hydrocarbons (TPH). Because of high total dissolved solids (TDS) in the groundwater, there was a need for pretreatment to control precipitation or scaling in the spray chamber and the granular activated carbon (GAC) units.

3.0 TECHNOLOGY DESCRIPTION

This section describes in further detail the air sparging technology introduced in Section 1.0. The description includes a presentation of the principles, applicability, advantages, disadvantages, and status of the technology. The objectives of the demonstration in terms of these features of the air sparging technology are presented in Section 4.0.

3.1 Principles of Air Sparging

In practice, air sparging can refer to two apparently similar, yet fundamentally different processes. In the first, clean air is injected at the bottom of a groundwater well to strip contaminants and aerate the water within the well (Herrling et al., 1994). In the second, clean air is injected directly into an aquifer. It is this second air sparging process that is the focus of this project. Practitioners have proposed using in situ air sparging to (1) treat contaminant source areas trapped within water-saturated and capillary zones, (2) remediate dissolved contaminant plumes, or (3) provide barriers to prevent dissolved contaminant plume migration. To minimize the potential for safety and health hazards (vapor migration to buildings and conduits, surface emissions, and enhanced soluble plume migration), air sparging systems often are integrated with soil vapor extraction and groundwater monitoring or recovery systems. As such, air sparging is a technology that complements, and is easily integrated with, existing hydrocarbon remediation practices.

When air sparging is applied, the result is a complex partitioning of contaminants among adsorbed, dissolved, and vapor states. Also, a complex series of removal mechanisms is introduced, including the removal of volatiles from the unsaturated zone, biodegradation, and the partitioning and removal of volatiles from the liquid phase. The mechanisms responsible for removal are dependent on the volatility of the contaminants. With a highly volatile contaminant, the primary partitioning is

into the vapor phase and the primary removal mechanism is through volatilization. By contrast, contaminants having low volatility will tend to partition into the adsorbed or dissolved phase and the primary removal mechanism is through biodegradation.

In situ air sparging remediates groundwater through a combination of volatilization and enhanced biodegradation. The induced air transport through the groundwater removes the more-volatile and less-soluble contaminants by physical stripping. Increased biological activity is stimulated by increased oxygen availability. For either or both mechanisms to operate efficiently, there must be good contact between the injected air and the groundwater. The behavior of sparging air in situ will be influenced by both the overall permeability and the spatial distribution of heterogeneities in permeability.

3.2 Waste and Media Applicability

Air sparging is an in situ technology potentially applicable in the remediation of contaminated groundwater and contaminant source areas trapped within water-saturated and capillary zones. Given that air sparging works through a combination of volatilization and biodegradation, any compound that is either volatile or aerobically biodegradable has the potential to be removed through air sparging. Petroleum hydrocarbons have been the most common target contaminants to date; however, air sparging is potentially applicable to solvent-contaminated sites as well.

3.3 Status

Air sparging is being applied by many practitioners; however, the behavior of sparging air introduced below the water table has not been studied in detail. Information on the distribution and flow configuration of the injected sparging air is essential to interpreting the performance of air sparging systems and evaluating their potential applicability. More information is needed to understand air sparging systems and to develop a protocol for predicting air sparging system performance.

4.0 PHYSICAL MODEL STUDIES

This section describes the physical model studies to be conducted in conjunction with the field studies. The relationships between air sparging performance and geology, system design, and operating conditions can more quickly and cost-effectively be assessed in physical model studies than can realistically be explored at a field study site. Compared to actual field studies, physical models are more easily monitored and characterized, and the experiments are of much shorter duration (days to weeks, rather than months to years in the field). Thus, to supplement and complement the data to be obtained from the field study sites, experiments will be conducted in physical models of various sizes and shapes. The two-dimensional laboratory-scale physical model study is described in the following paragraphs. The larger-scale physical model studies will be initiated in 1997.

It should be noted that, in the absence of validated predictive models, the quantitative results from physical models are not easily extrapolated to any given field setting. However, qualitative trends observed in the physical models are expected to extend to field sites. For example, if one were to determine in a physical model that changes in the air injection rate did not significantly affect the rate of oxygen transfer to groundwater, it would be assumed that changes in the air injection rate would not significantly affect oxygenation rates in field settings, provided the experiments had been conducted for a representative model geologic setting.

The two-dimensional physical model (8 ft × 4 ft × 2 inches) is depicted in Figure 10. The laboratory-scale size and the model shape shown in Figure 10 are especially convenient for conducting initial scoping experiments for a number of reasons: (1) the "geologic setting" can be changed quickly; (2) individual experiments typically can be conducted in less than 1 week; and (3) the air distribution pattern and how air distribution is affected by changes in process variables and stratigraphy are clearly discernible in the model.

The primary objective of the two-dimension laboratory-scale physical model was to study the volatilization of residual hydrocarbons during in situ air sparging applied to source zones. Results from the studies conducted in the two-dimensional physical model are presented in Appendix A in the thesis by (Das, 1996).

The oxygen transfer studies demonstrated that (1) oxygen transfer increases with increasing air injection rate at "low" air injection rates; (2) oxygen transfer levels off with increasing air injection rate at "high" air injection rates; (3) there appears to be an optimum air injection rate above which air injection increases cause permeability decreases; (4) the oxygen transfer rate increases with

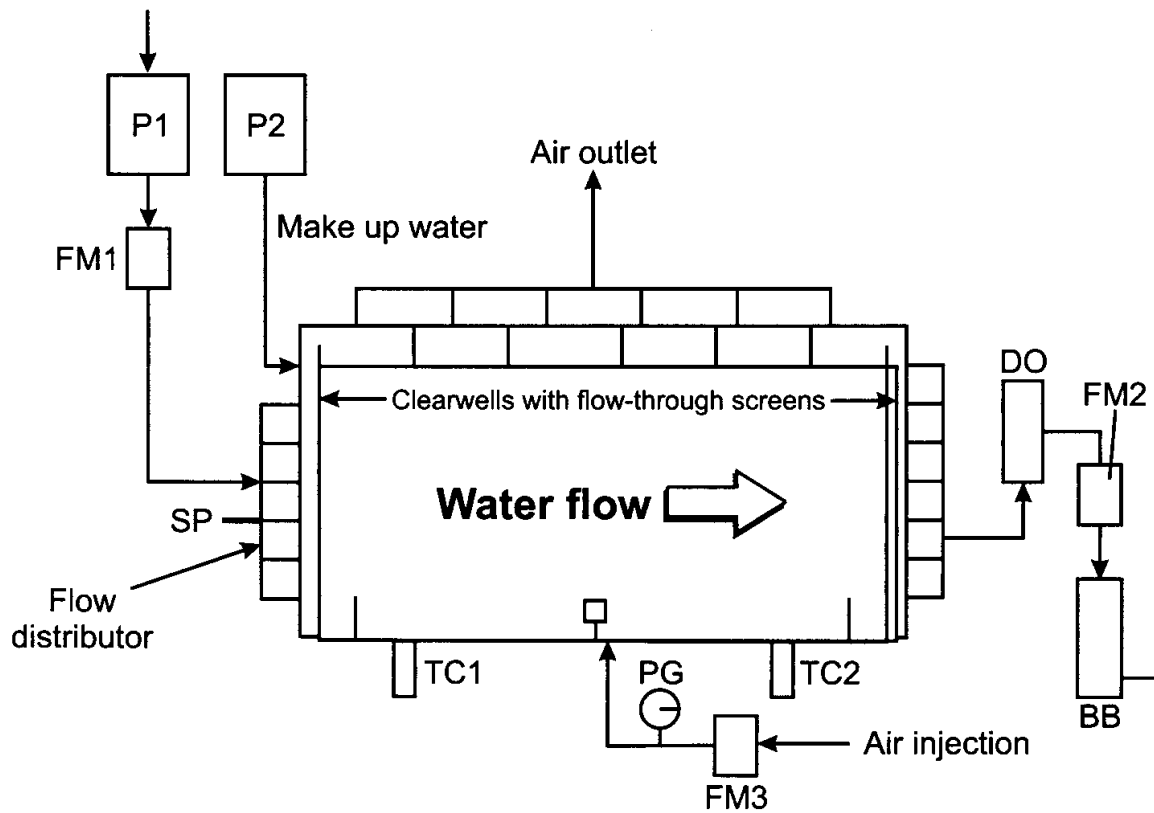

Explanation

P1	Peristaltic pump used for water circulation
P2	Peristaltic pump used for make up water during experiments
FM1, 2	0-300 cc/min water rotameters
FM3	2-25 L/min air rotameters
PG	0-150 inches-of-water-column magnahelic pressure gauge
DO	Flow-through Leeds and Northrup dissolved oxygen probe
BB	Nitrogen bubbler used to deoxygenate effluent water
TC1, 2	Type "J" thermocouples
SP	Liquid sample port used to obtain influent dissolved oxygen levels

AQUIMOD2.CDR

Figure 10. Schematic Diagram of the Two-Dimensional Laboratory-Scale Aquifer Physical Model

increasing groundwater velocity; and (5) the oxygen transfer rate appears to be insensitive to "pulsing" of the injected air.

Volatilization studies demonstrated that (1) "maximum" removal by volatilization is lower for air flow through wet media than through dry media (60% to 80% versus > 99%); (2) vapor concentrations initially vary smoothly with time, then exhibit large fluctuations about the average in wet media; (3) the flowrate affects the initial removal rate, but not the total mass recovered; and (4) pulsing the air flow causes changes in vapor concentration fluctuations and improves removal by volatilization.

5.0 FIELD DEMONSTRATION

This section details the activities associated with the air sparging field demonstration. Included in this section is a discussion of site characterization activities, installation details, and results of field tests.

5.1 Site Characterization

This section details the initial site characterization conducted at the bioventing test plot. Site characterization activities included a groundwater survey, and initial soil and groundwater analyses. The results of these activities are described in the following sections.

5.1.1 Groundwater Survey

A groundwater survey was conducted during May 1996 to verify that preselected areas were suitable for the planned air sparging study. The survey was conducted in two general locations which were judged to be suitable for the locations of Site 1 (source zone air sparging system) and Site 2 (dissolved-phase air sparging system) (Figure 11). Groundwater samples were collected with a Geoprobe direct-push soil/groundwater sampling rig. These samples were analyzed in the field using a headspace gas chromatography (GC) method. The GC used was a Series 9300 with a flame ionization detector. The GC was calibrated to known dissolved concentrations of benzene, toluene, ethylbenzene, *o*-xylene, and regular unleaded gasoline.

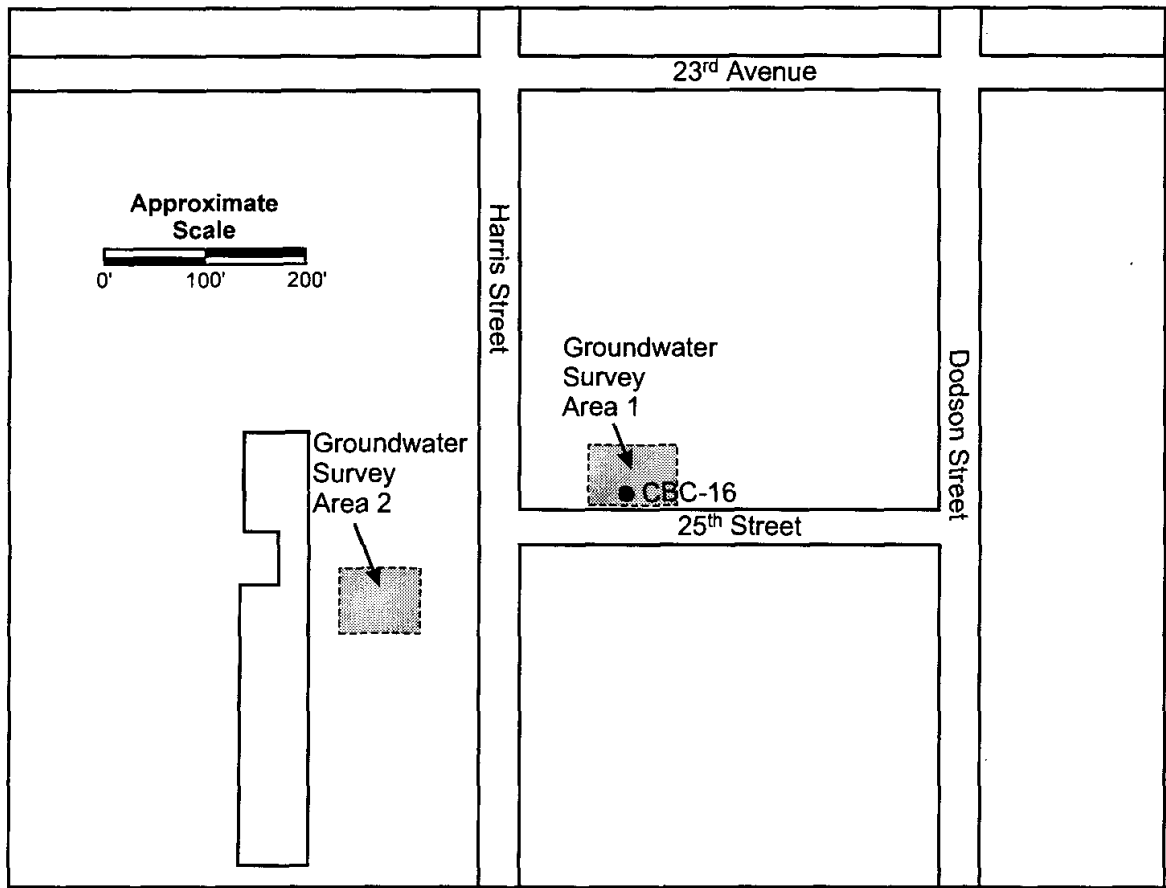

CD/Leeson/70-3

Figure 11. General Locations for the Initial Groundwater Survey

Results from the groundwater survey are shown in Tables 2 and 3. Dissolved concentrations are reported for BTEX and for total volatile hydrocarbons (TVHCs) in Table 2. The latter were quantified by comparing the cumulative GC response with headspace standards prepared with a regular unleaded gasoline. It should be noted that, while concentrations are reported for the target analytes, confirmatory dual-column chromatography or mass spectrometry was not performed to positively identify the presence of these target analytes. Thus, the concentrations reported for benzene, for example, might also include other compounds that co-elute at the same chromatographic retention time.

For reference, sampling points GP-01 through GP-06 and CDC-16 are located in Site 1, the area preselected for the source zone air sparging studies (Figure 12). Location CDC-16 is an existing monitoring well. The remaining sampling points (GP-07 through GP-15) are located downgradient of the source zone region in Site 2, the area preselected for possible dissolved-phase air sparging studies (Figure 13).

In general, the data suggest that the dissolved concentrations decrease with depth in the aquifer, with the highest dissolved concentrations observed in the 10- to 12-ft bgs interval. The data suggest a smear zone that is about 5 ft thick and a dissolved plume of up to 10 ft thick. In many locations, the concentrations are great enough to suggest the presence of nonaqueous immiscible-phase liquid hydrocarbons. At some locations a "sheen" of hydrocarbon was observed when collecting samples.

Groundwater samples were analyzed for MTBE at the Oregon Graduate Institute (Table 3). Significant concentrations of MTBE were found in all samples that were analyzed.

One concern raised by these results is the probable existence of nonaqueous immiscible-phase liquid hydrocarbons in the region planned for the dissolved-phase studies (downgradient of the UVB barrier control wells). The location for Site 2 was moved further downgradient in order to locate it within dissolved-phase contamination. The location for Site 1 remained in the area originally selected (Figure 14).

5.1.2 Collection and Analysis of Soil Samples

Initial soil sampling activities were conducted in June/July 1996. Soil samples were collected during installation of the multi-level samplers. Approximately 75 soil samples were collected for analyses of BTEX and TPH. Soil samples were collected in acetate sleeves using VibraCore's direct-

Table 2. Groundwater Survey Results for BTEX and TVHC

Location	Depth bgs (ft)	Benzene (µg/L)	Toluene (µg/L)	Ethylbenzene (µg/L)	Xylenes (µg/L)	TVHC (µg/L) ¹
CDC-16	NA	1,300	5,900	49	19,000	14,000
		150	470	130	960	1500
		38	130	56	390	820
GP1	18	34	130	180	260	1,500
	21	22	80	140	260	1,400
	24	8.1	640	57	140	510
GP2	8.5 - 10.5	4,500	6,000	2,000	8,000	26,000
		5,300	6,800	1,500	7,700	22,000
	10.5 - 12.5	13,000	17,000	2,600	22,000	37,000
	12.0 - 14.0	5,900	40,000	4,400	46,000	81,000
	16.0 - 18.0	200	640	130	1,200	1,100
GP2a	19.0 - 21.0	110	510	95	850	960
GP2b	19.0 - 21.0	76	350	71	630	610
GP3	9.0 - 11.0	1,600	270	920	7,200	12,000
		1,900	3,500	1,400	11,000	14,000
	11.0 - 13.0	890	1,100	400	3,600	590
	17.6 - 19.6	120	520	220	490	120
		170	810	1,300	630	180
		210	790	320	2,600	180
GP4	10.0 - 12.0	290	130	140	630	620
GP5	10.0 - 12.0	9,200	8,400	1,600	14,000	23,000
GP6	10.0 - 12.0	830	400	590	340	3,800
		110	290	79	680	2,300
	12.0 - 14.0	130	350	110	930	2,900

¹ Based on total area counts and a standard made from regular unleaded gasoline.

Table 2. Groundwater Survey Results for BTEX and TVHC

Location	Depth bgs (ft)	Benzene (µg/L)	Toluene (µg/L)	Ethylbenzene (µg/L)	Xylenes (µg/L)	TVHC (µg/L) ¹
GP7	10.0 - 12.0	5,300	3,400	1,100	4,400	26,000
	14.75-16.75	180	150	31	250	5,500
GP8	10.0 - 12.0	4,700	7,800	1,200	12,000	11,000
		3,900	7,200	1,200	13,000	28,000
	15.0 - 17.0	350	940	140	1,600	2,000
GP9	10.0 - 12.0	17,000	48,000	6,100	86,000	120,000
	15.0 - 17.0	710	3,500	430	5,700	3,900
GP10	10.0 - 12.0	6,100	65,000	5,000	58,000	120,000
		4,600	45,000	3,400	40,000	87,000
GP11	10.0 - 12.0 ²	24	110	11	180	140
	10.0 - 12.0 ²	41	170	33	310	260
	12.0 - 14.0 ²	43	400	56	890	820
	10.0 - 12.0	47	210	22	190	320
	12.0 - 14.0	27	190	17	270	460
GP12	10.0 - 12.0	19	630	18	210	370
GP13	12.0 - 14.0	730	23,000	1,500	22,000	52,000
		710	22,000	1,100	20,000	47,000
GP14	10.0 - 12.0	1,200	13,000	580	9,500	22,000
GP15	10.0 - 12.0	5,900	4,500	3,400	4,400	65,000

¹ Based on total area counts and a standard made from regular unleaded gasoline.
² Lower concentrations may have been caused by a clogged injection needle or a leaking septum.

Table 3. Groundwater Survey Results for MTBE

Sample	MTBE Concentrations ($\mu\text{g/L}$)
GP8-1	4,337
GP8-2	2,287
GP9-1	1,358
GP9-2	327
GP10-1a	375
GP10-1b	388
GP11-2	265
GP12-1	257
GP13-1	294
GP14-1	337
GP15-1	1,737

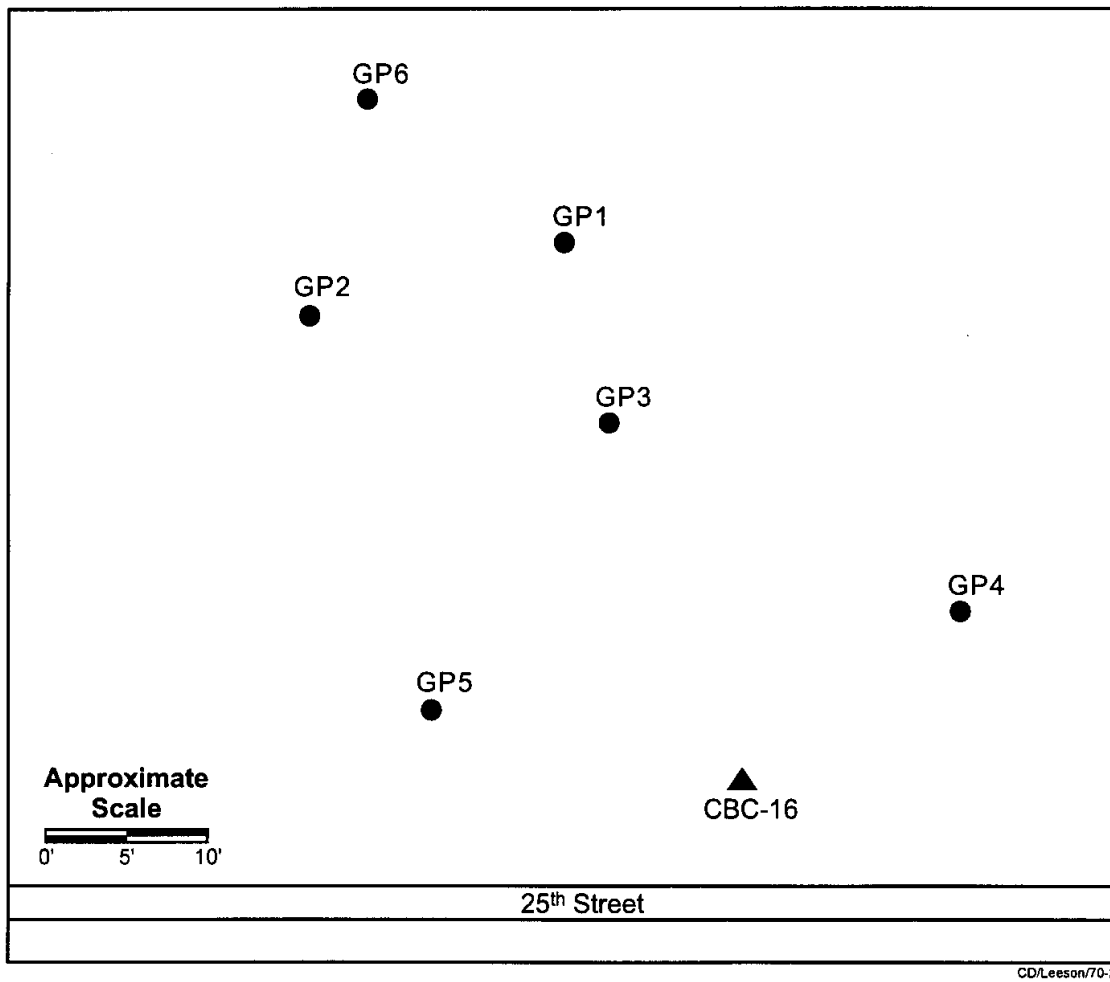

CD/Leeson/70-2

Figure 12. Locations of Groundwater Survey Points at Site 1, Port Hueneme, CA

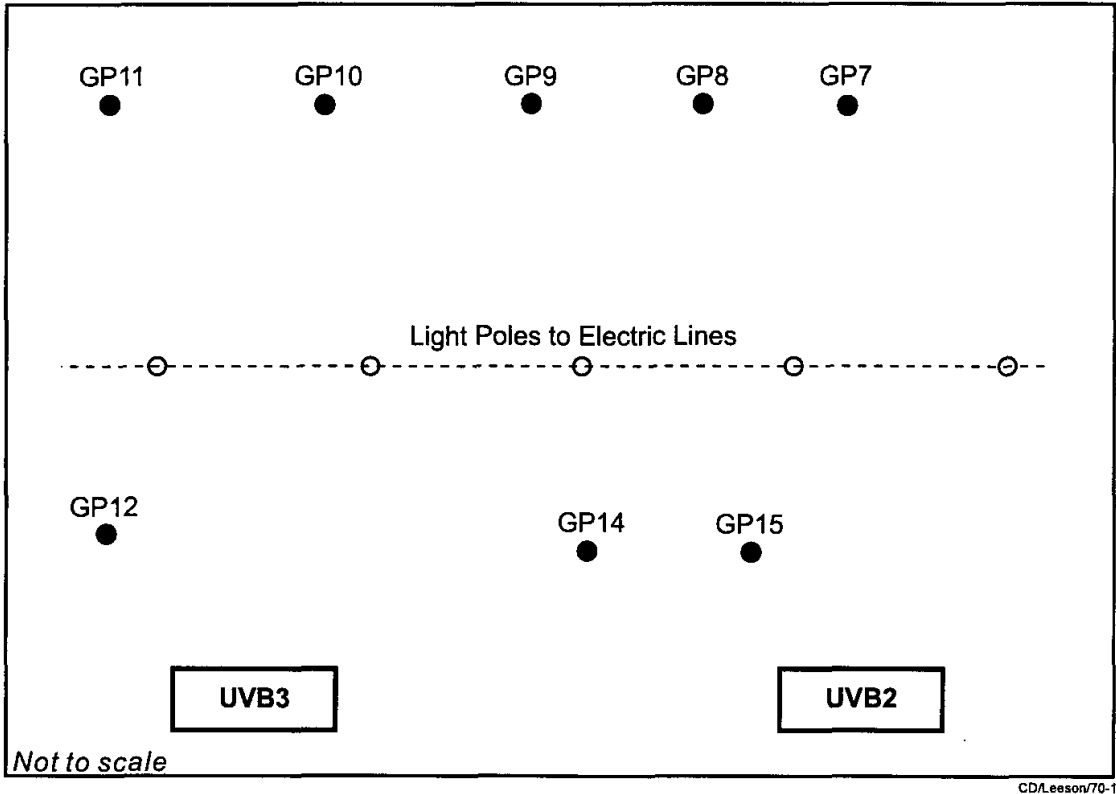

Figure 13. Locations of Groundwater Survey Points at Site 2, Port Hueneme, CA

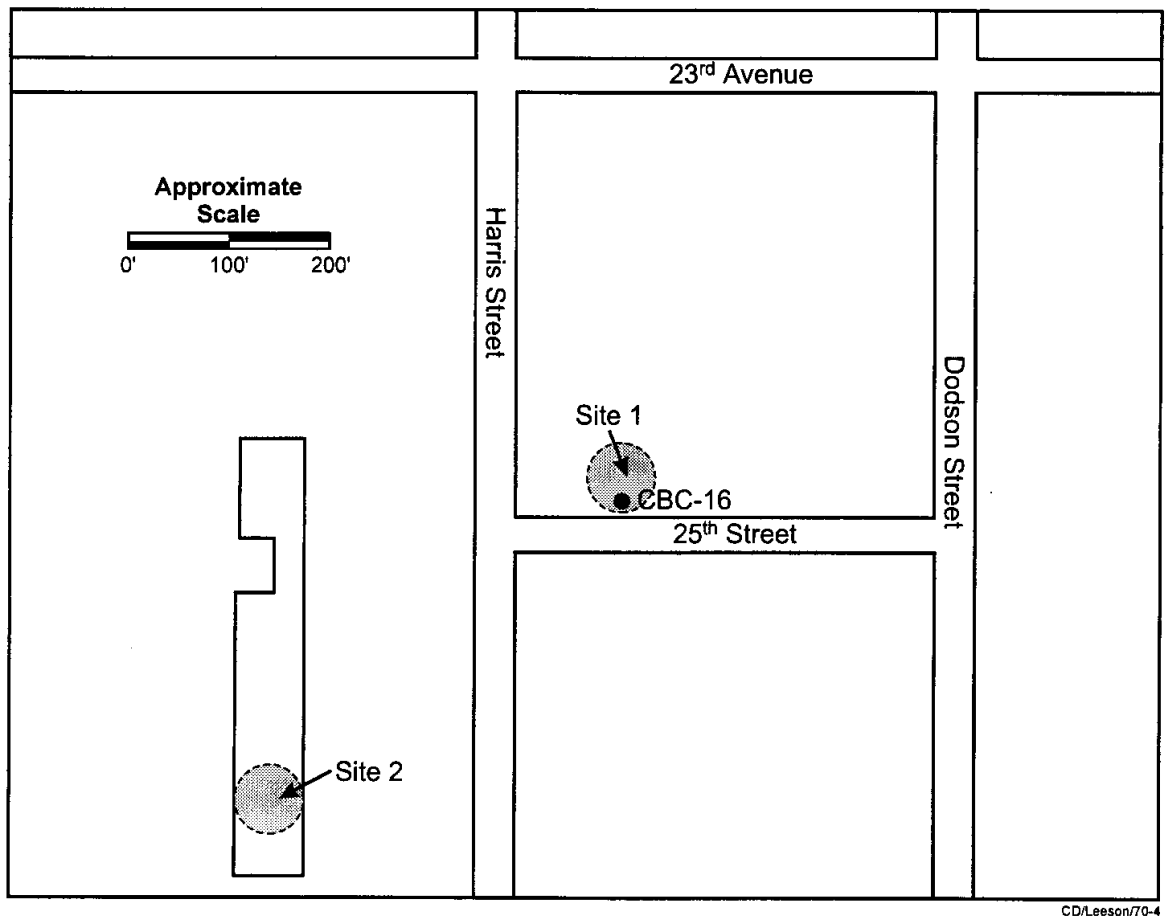

Figure 14. Locations of the Air Sparging Systems at the Naval Exchange Gas Station, Port Hueneme, CA

push technique at depth intervals from 4 ft bgs (1.2 m) to 19 ft bgs (5.8 m) from a total of seven boreholes. Each soil sample was labeled to identify the site, boring location and depth, and time of collection. Samples were recorded on a chain-of-custody sheet and shipped on ice to Alpha Analytical for analysis. Soil samples were analyzed by GC for petroleum contamination using U.S. EPA Method 8015. Specific compounds measured were TPH, benzene, toluene, ethylbenzene, and xylenes. Raw data from these analyses and analytical methods are presented in Appendix B. Soil boring logs are presented in Appendix C.

Results of the soil analyses are shown in Tables 4 and 5. At Site 1, as was seen during the groundwater survey, the heaviest contamination was found at the 10- to 12-ft bgs depth interval, with TPH concentrations ranging from 1,600 mg/kg to 3,800 mg/kg (Table 4). As expected, contamination at Site 1 was significantly greater than contamination levels at Site 2, where contaminants were below detection limits at nearly all depth intervals (Table 5).

5.1.3 Collection and Analysis of Groundwater Samples

Groundwater samples were collected at Site 1 from each of the multi-level samplers during September 1996. Samples were collected using a low-flow peristaltic pump (Masterflex Co., Barrington, IL) and collected in a 40-mL vial with a septa-lined cap. Groundwater samples were analyzed in the field and at an analytical laboratory. Samples measured in the field were analyzed as described in Section 5.1.1. A full data summary of the field analyses is provided in Appendix D. Samples sent to the analytical laboratory were acidified at the time of collection, placed on ice, and shipped to Alpha Analytical for analyses of BTEX and TPH. Laboratory analytical reports are provided in Appendix B.

Sample results of the field analyses are shown in Table 6. The data show that the highest concentrations of dissolved hydrocarbons are found at the water table to 4 ft below, as would be expected for a release of petroleum fuel. These results are in agreement with samples collected during the initial groundwater survey.

Laboratory analytical results are shown in Table 7. In general, laboratory results show lower concentrations of BTEX than do the field measurements. The differences are more distinct when laboratory measurements show very low concentrations of BTEX. At higher concentrations, results are more comparable. These differences could be the result of some sample deterioration during shipment to the analytical laboratory or could be the result of interferences in the field analyses.

Table 4. Soil Analyses from Site 1, Port Hueneme, CA Averaged by Depth

Depth	Contaminant Concentration (mg/kg)				
	Benzene	Toluene	Ethylbenzene	Xylenes	TPH
4.0'	<0.00050	0.085	<0.00050	0.0013	8.8
5.0'	0.017	0.13	0.0022	0.11	5.4
6.0'	<0.00050	0.035	<0.00050	<0.00050	< 10 ¹
7.0'	1.4	3.5	7.7	45	690
8.0'	0.21	0.24	1.4	7.4	82
9.0'	0.059	0.17	0.25	1.1	10
10.0'	3.4	77	38	210	1,600
11.0'	13	200	93	480	3,800
12.0'	11	87	49	230	1,900
13.0'	1.7	10	6.0	31	200
15.0'	0.023	0.16	0.069	0.37	< 10 ¹
17.0'	0.0058	0.053	0.017	0.091	< 10 ¹
19.0'	0.0018	0.028	0.0088	0.054	< 10 ¹

Table 5. Soil Analyses from Site 2, Port Hueneme, CA Averaged by Depth

Depth	Contaminant Concentration (mg/kg)				
	Benzene	Toluene	Ethylbenzene	Xylenes	TPH
4.0'	<0.00050	0.039	<0.00050	<0.00050	<10 ¹
5.0'	<0.00050	0.027	<0.00050	<0.00050	<10 ¹
7.0'	<0.00050	<0.00050	<0.00050	<0.00050	<10 ¹
8.0'	<0.00050	<0.00050	<0.00050	<0.00050	<10 ¹
9.0'	<0.00050	0.0066	<0.00050	<0.00050	<10 ¹
10.0'	0.017	<0.00050	<0.00050	<0.00050	<10 ¹
11.0'	<0.00050	<0.00050	<0.00050	<0.00050	<10 ¹
12.0'	<0.00050	<0.00050	<0.00050	<0.00050	<10 ¹
13.0'	<0.00050	<0.00050	<0.00050	<0.00050	<10 ¹
15.0'	<0.00050	<0.00050	<0.00050	<0.00050	<10 ¹
16.0'	<0.00050	<0.00050	<0.00050	<0.00050	<10 ¹
17.0'	<0.00050	0.0072	<0.00050	<0.00050	<10 ¹
19.0'	<0.00050	<0.00050	<0.00050	<0.00050	<10 ¹

Table 6. Vertical Distribution of Dissolved Hydrocarbons at Multi-Level Sampler MP3, Site 1, Port Hueneme Field Analyses

Depth (ft bgs)	Benzene ($\mu\text{g/L}$)	Toluene ($\mu\text{g/L}$)	Ethylbenzene ($\mu\text{g/L}$)	<i>o</i>-Xylene ($\mu\text{g/L}$)
10	870	250	2,200	890
11	4,900	2,000	20,300	7,400
12	160	<200	<200	<200
13	1,900	170	96	110
14	270	22	130	180
15	<15	110	80	220
16	19	57	49	190
17	34	110	160	270
18	NS	NS	NS	NS
19	<15	100	270	230

Table 7. Laboratory Groundwater Analyses from Site 1, Port Hueneme, CA

Multi-Level Sampler	Contaminant Concentration (mg/L)				
	Benzene	Toluene	Ethylbenzene	Xylenes	TPH
MP1-11.0	5.1	13	1.4	7.8	32
MP1-15.0	0.0035	0.0037	0.019	0.024	1.3
MP1-19.0	0.0060	0.0061	0.0083	0.0029	0.14
MP7-15.0	0.0024	0.0054	0.066	0.047	4.0
MP7-19.0	0.0092	0.024	0.045	0.11	3.8
MP10-11.0	1.5	0.027	1.8	2.0	9.6
MP10-15.0	<0.00050	<0.00050	<0.00050	<0.00050	0.89
MP10-18.0	0.00056	0.00094	0.00068	0.00075	<0.050

5.2 Installation Details

The two test sites were located as shown in Figure 14. The installations at each test site were installed the same in order to compare results between the two sites. Schematic diagrams of the sites showing locations of monitoring wells, SVE directional wells, multi-level samplers, the sparge well, and the neutron probe access tubes are shown in Figures 15 and 16.

The air sparging system at Site 1 consists of a Roots Universal RAI vacuum pump which powers the air compressor for air injection. An internal combustion engine (ICE) is used to treat off-gases when the system is configured for soil vapor extraction. The four monitoring wells are used for soil vapor extraction. Operating flowrates vary depending on the experimental setup.

The air sparging system at Site 2 consists of an air compressor plumbed to the sparge well for air injection. A Gast REGENAIR blower is plumbed to the monitoring wells for soil vapor extraction. Operating flowrates vary depending on the experimental setup.

A brief description of the construction details of each installation in the test plot is given in the following sections. All installations were installed using VibraCore's direct-push technique. When possible, sand and bentonite packs were placed around installations as shown in the cross sections in the following sections.

5.2.1 Construction Details of Sparge Wells

One sparge well was installed at each test site. A schematic diagram showing a cross section of the sparge wells is shown in Figure 17. The 2-inch-diameter sparge wells were installed to a depth of approximately 20 ft (6.1 m) with approximately 2 ft (1.2 m) of 10-slot schedule 40 polyvinyl chloride (PVC) screen and 19 ft (5.8 m) of PVC casing finished 1 ft (0.30 m) above grade. A 2/12 silica sand and filter pack was installed across the screened interval at Site 1 and bentonite pellets were used to fill the remaining annular space to grade. The bentonite pellets were frozen prior to use for installation below the water table. At Site 2, a sand pack could not be installed due to heaving sand, but bentonite pellets were installed above the screened interval to the surface.

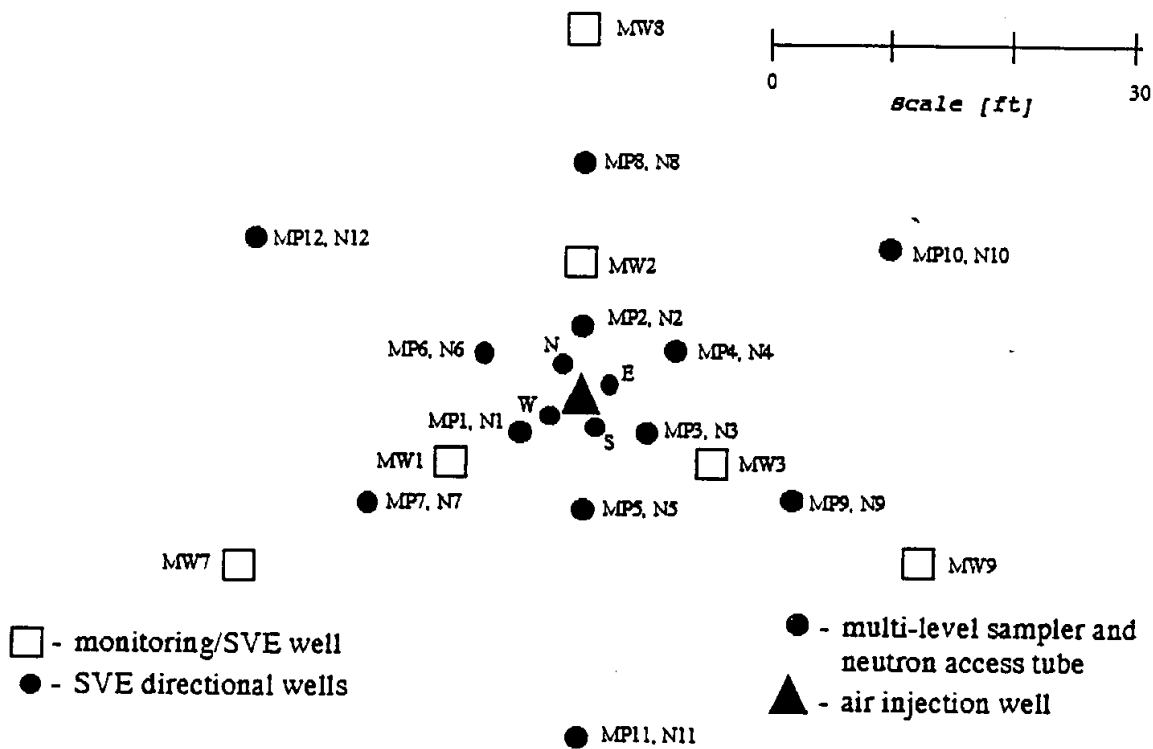
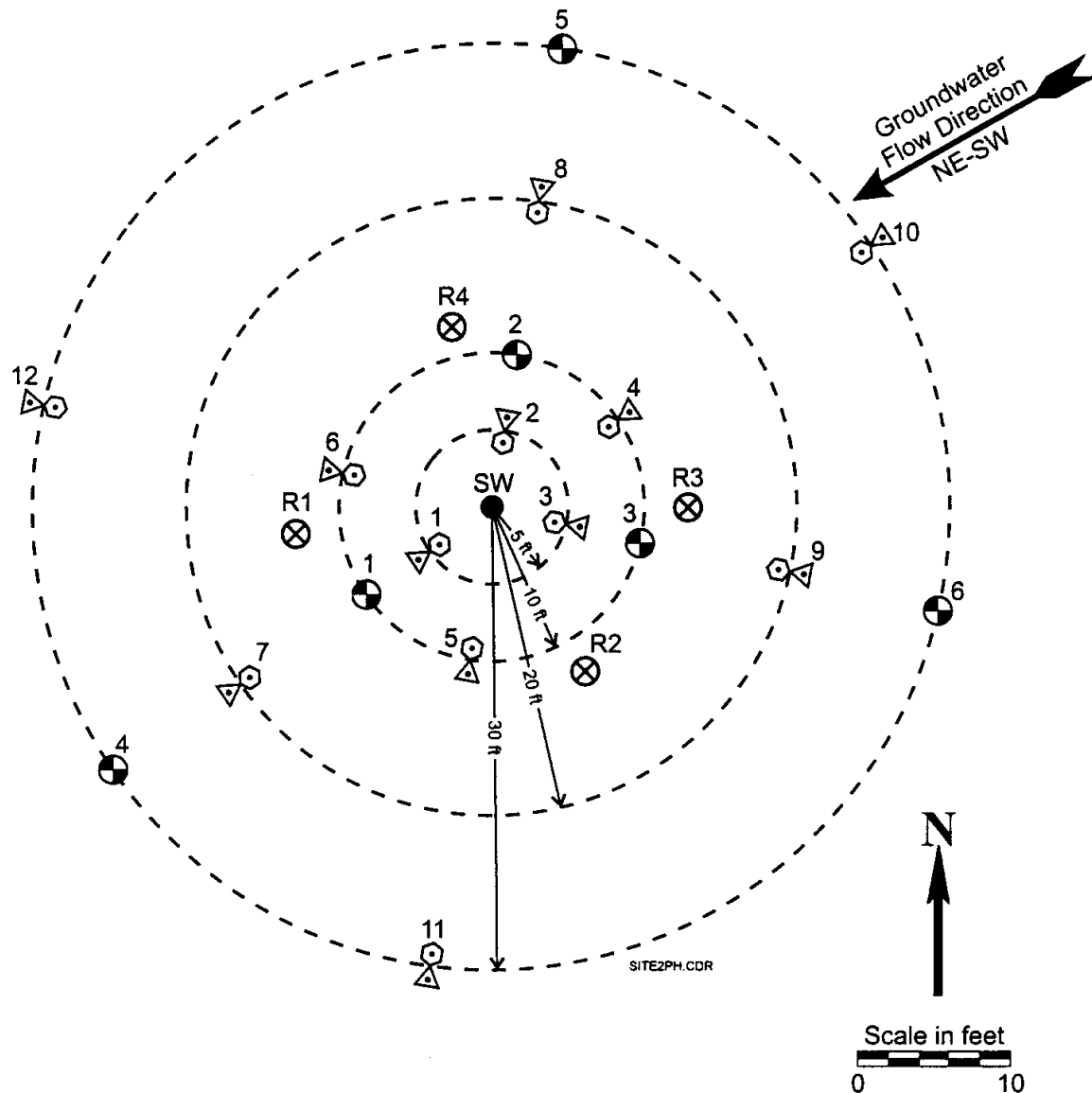

Figure 15. Schematic Diagram Showing Locations of Installations at Site 1, Port Hueneme, CA



- Explanation
- SW ● Sparge Well
 - ⊗ Neutron Probe Access Tube and Subsurface Monitoring Device
 - ⊕ Monitoring Well
- MRC Locations:
- R1 ⊗ Borehole Radar Location

Figure 16. Schematic Diagram Showing Locations of Installations at Site 2, Port Hueneme, CA

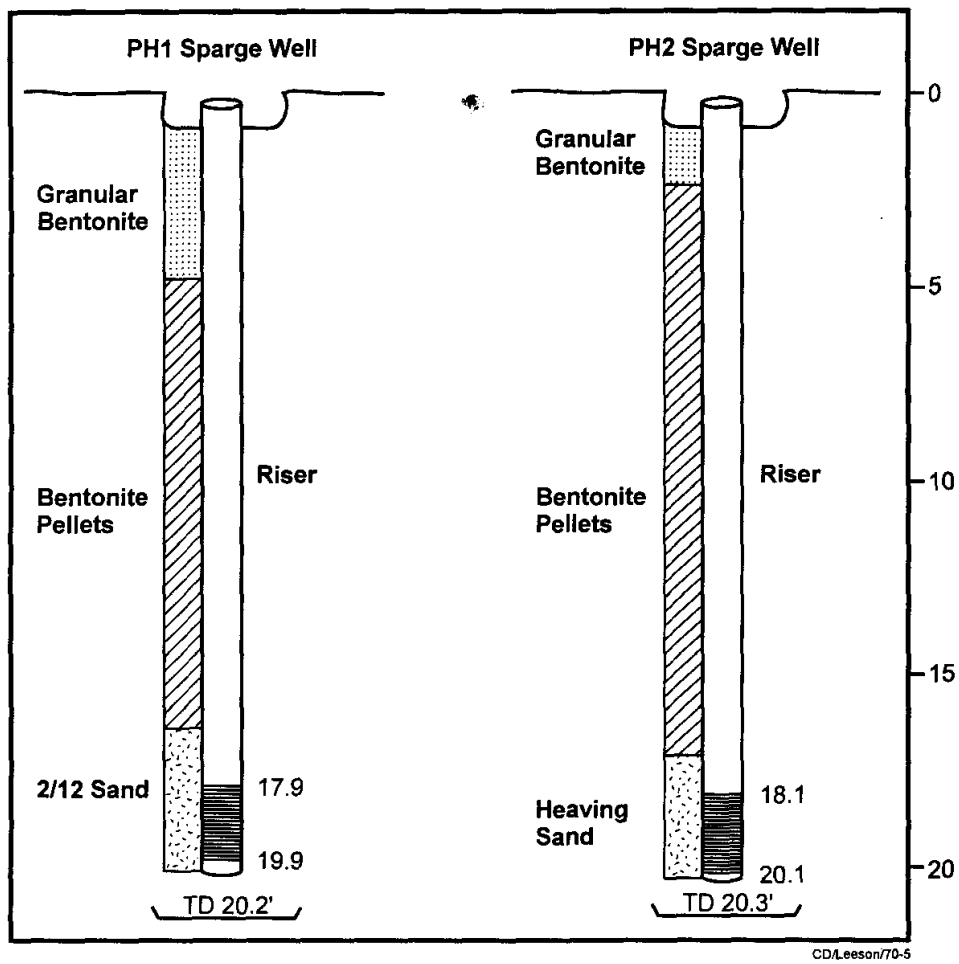

Figure 17. Schematic Diagram Showing Cross Section of Sparge Wells

5.2.2 Construction Details of Multi-Level Samplers

Twelve 14-level multi-level samplers were installed using the VibraCore direct-push technique. The sampling intervals were installed in a 2-inch-diameter Schedule 80 PVC riser. Each sampling interval consisted of 1/8-inch stainless steel tubing with a 1/8-inch Swagelock fitting at the end (Figure 18). The stainless steel tubing was covered with polyvinyl tubing to insulate them from each other. This allows the multi-level samplers to be used for electrical resistance measurements as well as groundwater and soil gas sampling. The stainless steel tubing was bent so that the Swagelock fitting terminated at a 100-mesh stainless steel screen which was PVC-welded to the PVC riser. The fine mesh screen will prevent the accumulation of particles within the stainless steel tubing which could block or interfere with sampling. Sampling intervals were installed at each multi-level sampler with the Swagelock fitting at the following depths bgs: 2, 4, 6, 8, 10, 11, 12, 13, 14, 15, 16, 17, 18, and 19 ft. All sampling intervals were color-coded, with colored polyvinyl tubing associated with a specific depth as follows: clear = 2 ft; orange = 4 ft; yellow = 6 ft; brown = 8 ft; green = 10 ft; black = 11 ft; blue = 12 ft; clear = 13 ft; orange = 14 ft; yellow = 15 ft; brown = 16 ft; green = 17 ft; black = 18 ft; and blue = 19 ft. A schematic diagram showing a cross section of a typical multi-level sampler is shown in Figure 19.

5.2.3 Construction Details of Groundwater Monitoring Wells

A schematic diagram showing a cross section of a typical groundwater monitoring well is shown in Figure 20. Six 2-inch-diameter PVC groundwater monitoring wells were installed at each site. The monitoring wells were installed to a total depth of 20 ft (6.1 m) with 15 ft (4.6 m) of 10-slot screen and 6 ft (1.8 m) of casing. The annular space outside the screened interval of the monitoring wells was filled with a medium-grade silica sand filter pack. The remaining annular space was sealed to the surface with a bentonite plug.

5.2.4 Construction Details of Neutron Probe Access Tubes

A schematic diagram showing a cross section of a typical neutron probe access is shown in Figure 21. Twelve 2-inch-diameter PVC neutron probe access tubes were installed at each site. The annular space was filled with a medium-grade silica sand filter pack to approximately 2 ft below

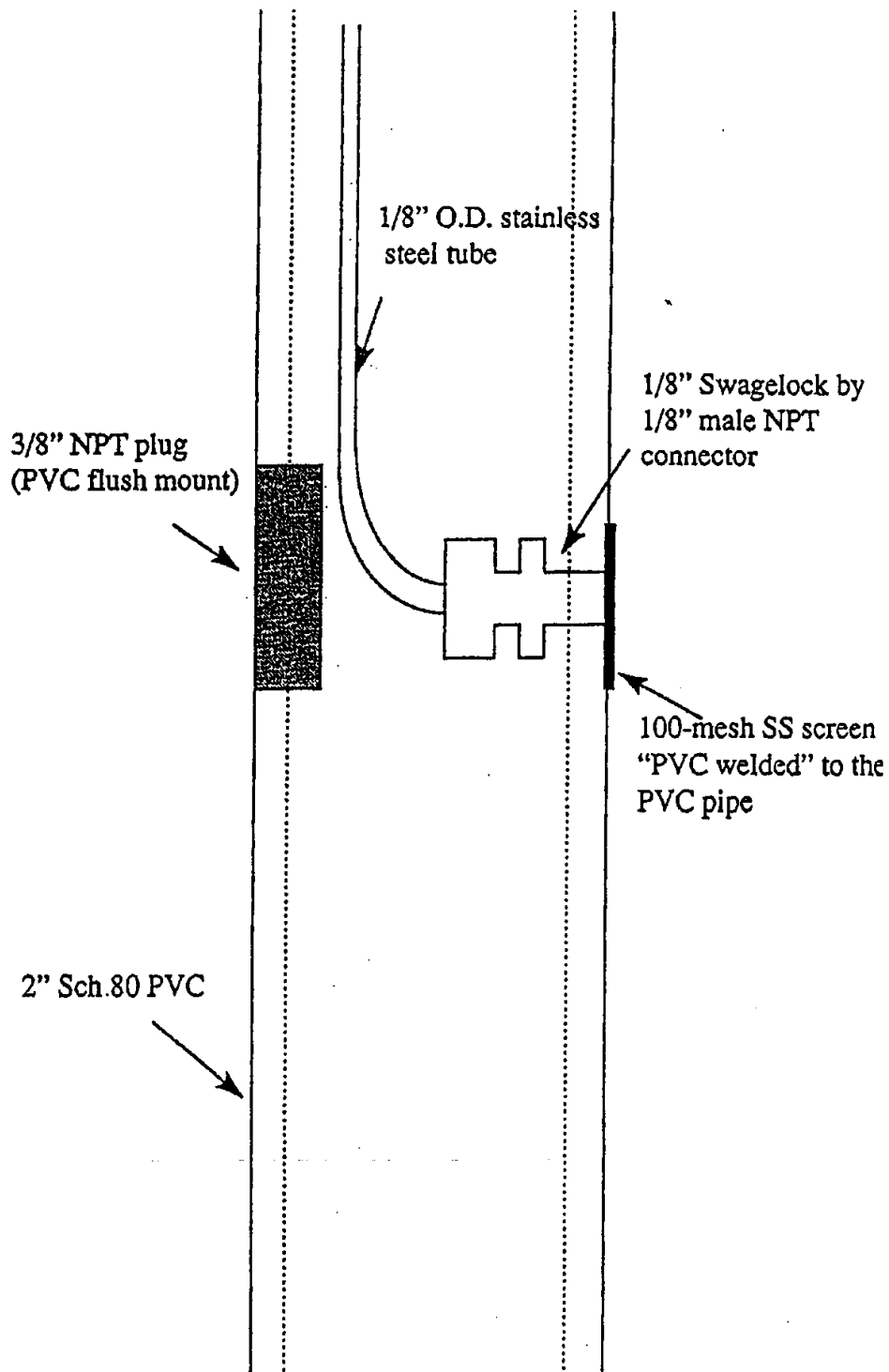

Figure 18. Schematic Diagram Showing a Cross Section of a Single Sampling Point Within a Multi-Level Sampler

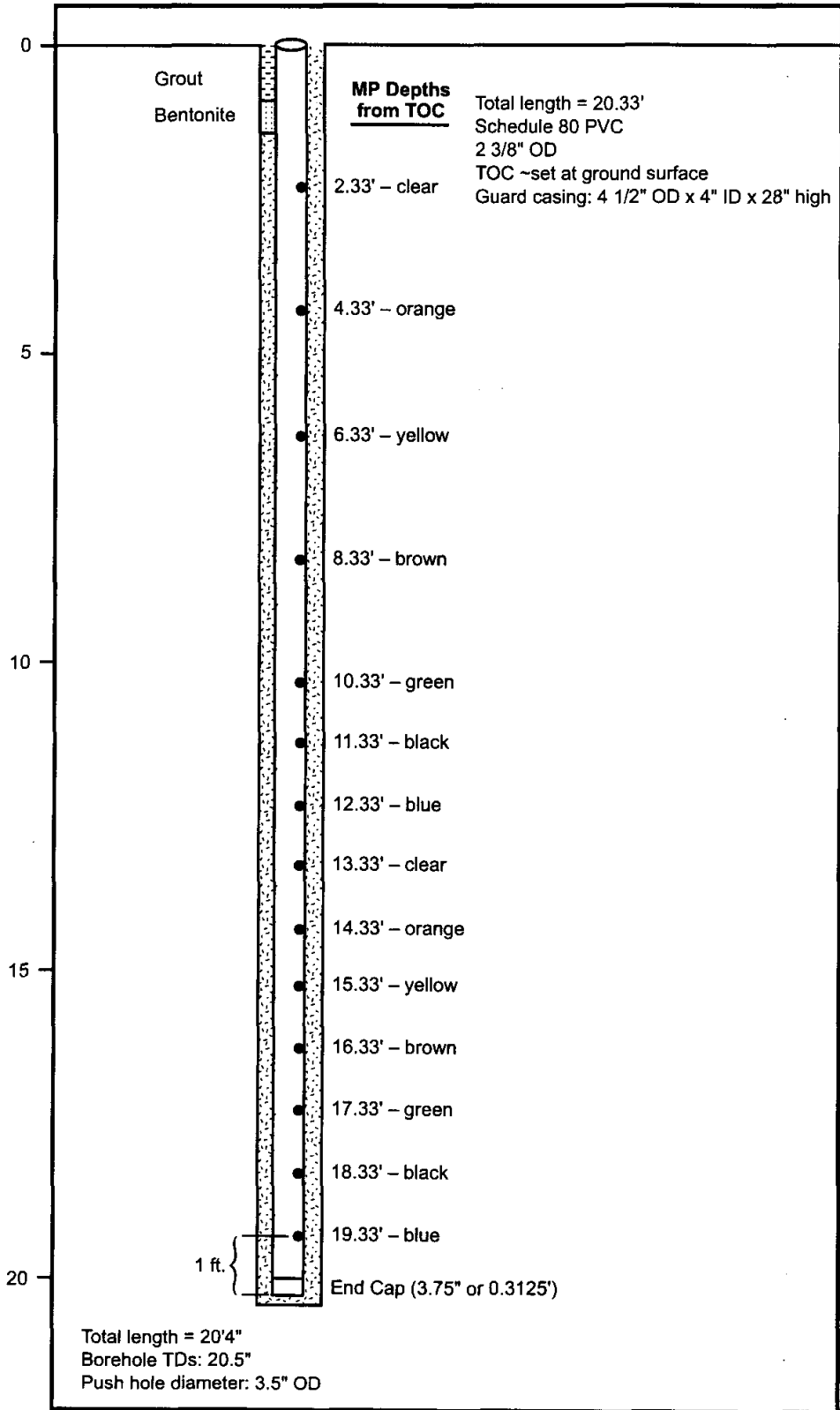
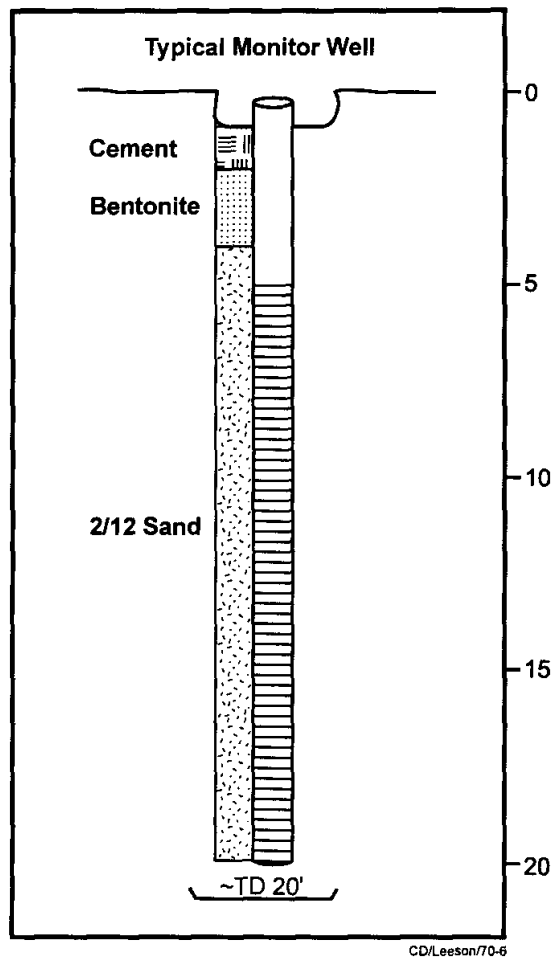
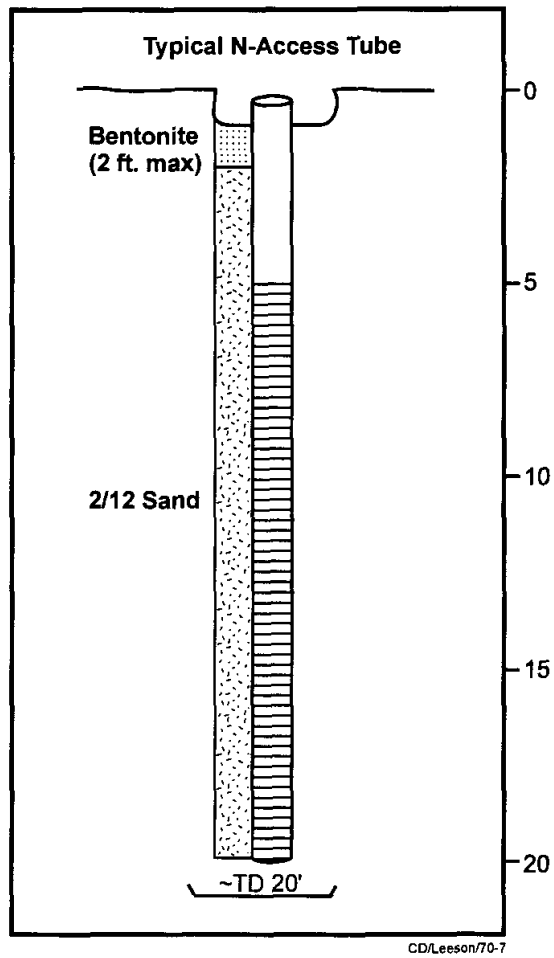

Figure 19. Schematic Diagram Showing a Cross Section of a Typical Multi-Level Sampler



CD/Leeson/70-6

Figure 20. Schematic Diagram Showing a Cross Section of a Typical Groundwater Monitoring Well



CD/Leeson/70-7

Figure 21. Schematic Diagram Showing a Cross Section of a Typical Neutron Probe Access Tube

grade. The remaining annular space was sealed to the surface with a bentonite plug. The neutron probe access tubes are able to be used for neutron probe, Troxler, and borehole radar measurements.

5.2.5 Construction Details of Directional Soil Vapor Extraction Wells

Four 1-inch-diameter PVC directional soil vapor extraction wells were installed at Site 1. The wells were installed to a total depth of 10 ft (3.0 m) with 5 ft (1.5 m) of 10-slot screen and 6 ft (1.8 m) of casing. The annular space outside the screened interval of the monitoring wells was filled with a medium-grade silica sand filter pack. The remaining annular space was sealed to the surface with a bentonite plug.

5.3 Field Tests and Process Monitoring

A number of field measurements were conducted at the air sparging sites with the system configured for soil vapor extraction only or for air sparging with soil vapor extraction. The field measurements collected under this study to date can be grouped into four general categories: (1) dissolved oxygen measurements; (2) chemical contaminant measurements; (3) geophysical measurements; and (4) tracer measurements. Methods and results for these field measurements are provided in the following sections.

5.3.1 System Operation

5.3.1.1 Site 1: Source Zone System

Soil vapor extraction was conducted at the test site prior to initiating air sparging to establish a baseline off-gas concentration of volatile compounds and to conduct preliminary tracer tests to establish flow patterns. The four soil vapor extraction directional wells were used. Air was extracted at a rate of approximately 32 cfm (8 cfm from each well).

Soil vapor extraction was initiated on 3 September 1996 and was continued for 10 days. The system was shut down on September 13 pending approval of the modified air permit. Soil vapor extraction was re-initiated on 18 October 1996. Air sparging was initiated on 26 October 1996 at a flowrate of approximately 5 cfm with the soil vapor extraction system still in operation. The air

sparging system operated until 7 November 1996, at which point it shut down due to equipment problems. The mechanical problems were repaired by early December; however, it was decided to wait until January to restart the system.

5.3.1.2 Site 2: Dissolved-Phase Zone System

The soil vapor extraction system was initiated on 3 September 1996 at a flowrate of 30 cfm and was operated for 10 days. The system was shut down on September 13 pending approval of the modified air permit. Although the modified air permit was received, it was decided to delay initiating testing at Site 2 until the optimal test methods had been determined at Site 1.

5.3.2 Dissolved Oxygen Measurements

Dissolved oxygen measurements were made at each of the 12 multi-level samplers on four occasions: 1 September 1996; 19 October 1996; 25 October 1996; and 28 October 1996. Samples were collected using a low-flow peristaltic pump (Masterflex Co., Barrington, IL). Samples were measured during continuous flow using a YSI Model 5776 Oxygen Probe. The first three sampling events were conducted prior to initiating air sparging. The sampling event on 28 October 1996 was conducted 2 days after air sparging was initiated. Results from all sampling points are provided in Appendix D.

Dissolved oxygen concentrations prior to initiating air sparging were below 2 mg/L at all multi-level samplers and at all depths. After initiation of air sparging, dissolved oxygen concentrations rose significantly at some depth intervals. Dissolved oxygen concentrations were most influenced at a distance of 5 and 10 ft from the sparge well, although detectable changes also were detected at a distance of 20 ft from the sparge well (Figure 22). No significant changes could be detected at a distance of 30 ft from the sparge well.

5.3.3 Chemical Contaminant Measurements

Groundwater samples were collected for analyses of BTEX as described in Section 5.1.3. Samples were collected pre- and post-air sparging. A list of the area concentration counts and the calculated concentrations is provided in Appendix D. TPH concentrations in the system off-gas also

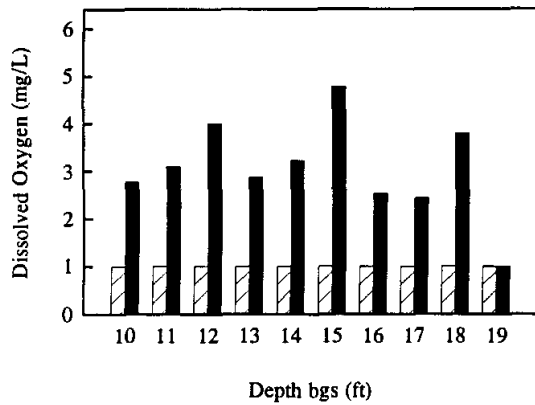

A. 5 ft radial distance

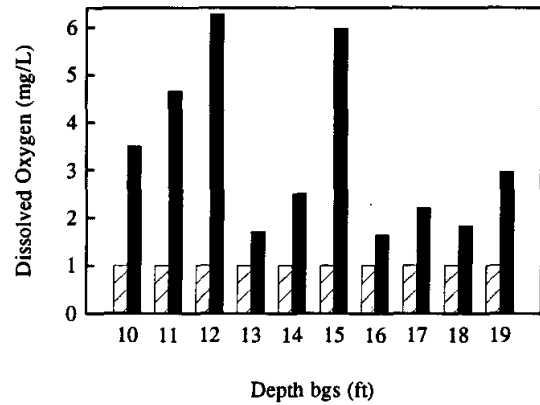

B. 10 ft radial distance

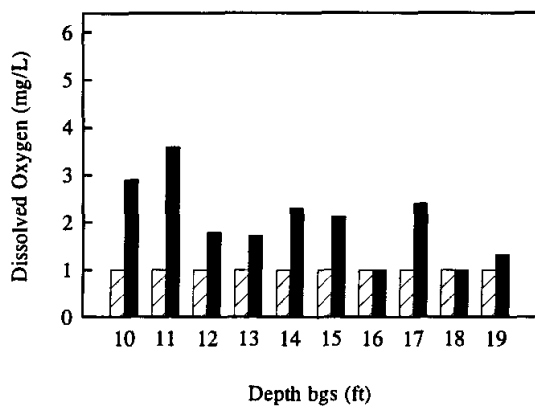

C. 20 ft radial distance

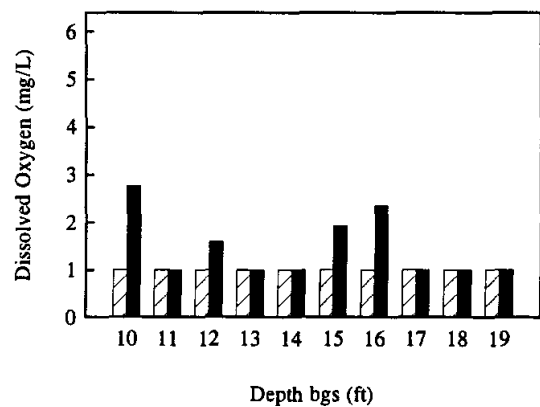

D. 30 ft radial distance

c:\plot50\sparging\do-comb.sp5

Figure 22. Dissolved Oxygen Concentrations Averaged by Depth at Multi-Level Samplers Located 5, 10, 20, and 30 ft Radially from the Sparge Well: Pre- and Post-Air Sparging

were measured from one week prior to air sparging to three days after initiating air sparging. TPH concentrations were measured with a portable thermal conductivity detector which was calibrated to hexane.

BTEX concentrations in groundwater appeared to decrease at many of the sampling points 2 days after initiating air sparging. This trend was most apparent at distances of 5 and 10 ft from the sparge well. An example of average benzene concentration versus depth is shown in Figure 23. Beyond this distance, there appeared to be little effect on contaminant concentration.

A 2-day air sparging period may not be sufficient time to observe significant concentrations in contaminant concentrations. Future experiments will include analyses of contaminants after the sparging system has been operating for a significant period of time.

As shown in Figure 24, TPH concentrations in the system off-gas appeared to decrease with time as soil vapor extraction progressed. Once air sparging was initiated, contaminant concentrations increased dramatically in the off-gas. However, concentrations quickly dropped within two days after the initiation of air sparging.

5.3.4 Geophysical Measurements

Geophysical measurements included the use of neutron probe measurements, electrical resistance measurements, and Troxler probe measurements. Due to difficulties in using the Troxler probe during initial measurements, these results are not discussed in this section.

A CPN Hydroprobe was used for the neutron probe measurements, and the counting time for each measurement was 16 seconds. The neutron probe data were collected at 1-ft intervals bgs in the neutron probe access tubes. The measurements were collected prior to and approximately 72 hours after initiation of air sparging. The difference between these two measurements was used to determine changes in water content. Based on a simple calibration scheme using difference in counts between the groundwater and vadose zone, the fractional air saturation was calculated. The electrical resistance data were collected using the multi-level samplers. The measurements were made between pairs of sampling points and were collected prior to and approximately 48 hours after initiation of air sparging.

The neutron probe data indicate that zones with significant air saturation (i.e., $S_a > 0.1$) were relatively scattered in the vicinity of the sparge well (Figure 25). Several qualitative observations can be made about Figure 25. Probably the most significant is that no significant zones of air saturation

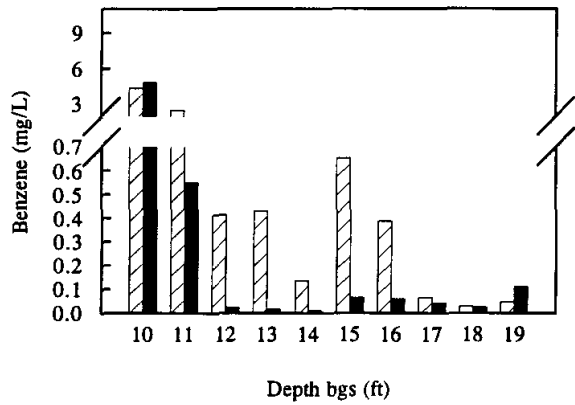

A. 5 ft radial distance

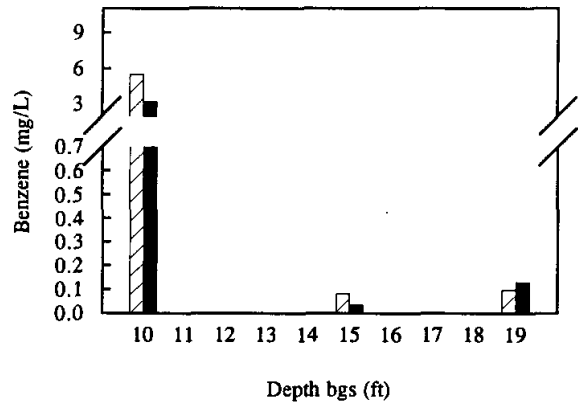

B. 10 ft radial distance

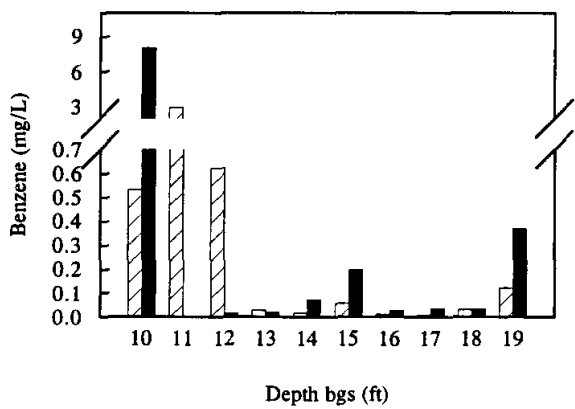

C. 20 ft radial distance

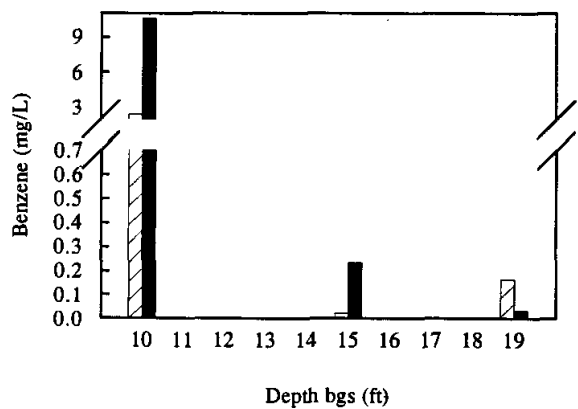

D. 30 ft radial distance

c:\plot50\uparging\benzene.sp5

Figure 23. Benzene Concentration Averaged by Depth at Distances of 5, 10, 20, and 30 ft from the Sparge Well

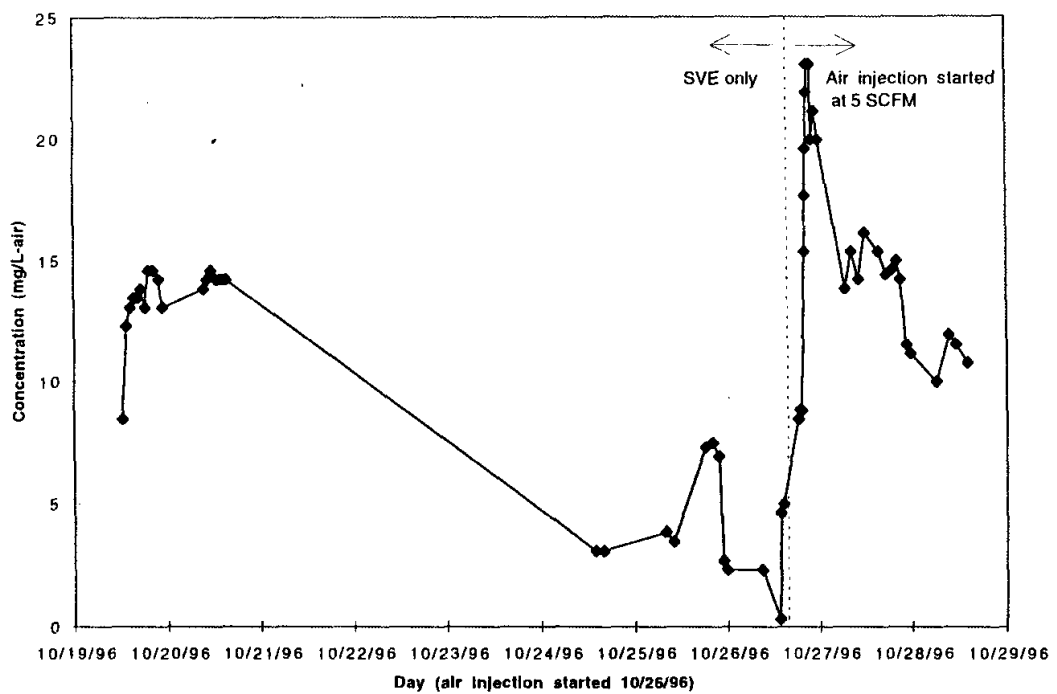

Figure 24. TPH Concentrations in System Off-Gas Pre- and Post-Air Sparging

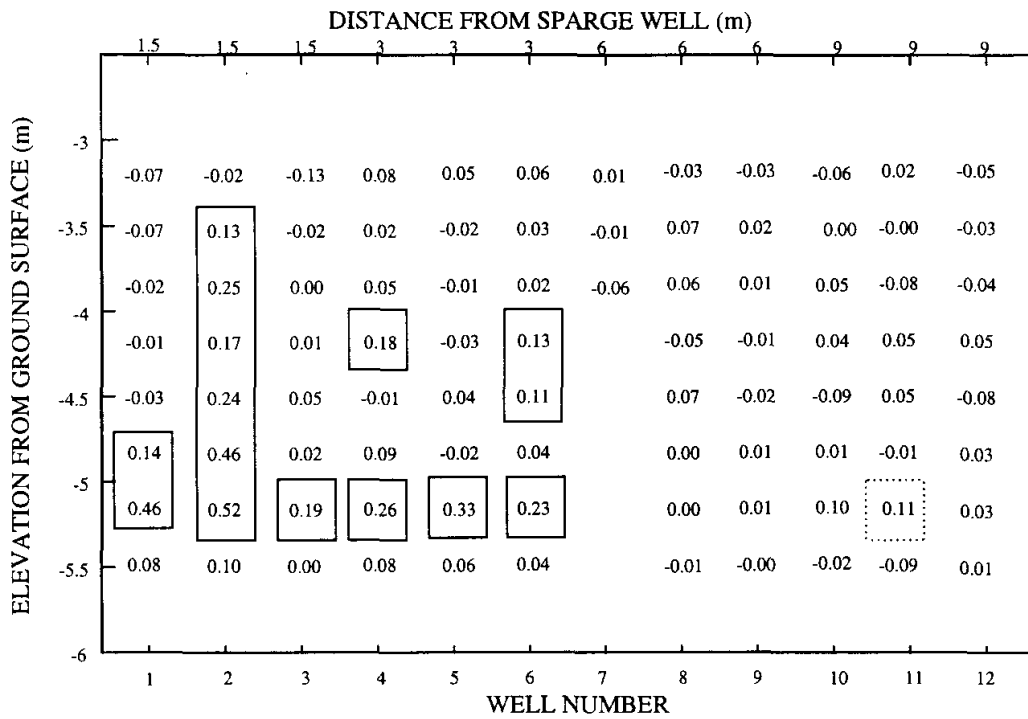

Figure 25. Air Saturation Data Estimated From Neutron Probe Measurements

are found beyond 10 ft (3 m) from the sparge well. (The data considered to be significantly different from zero in this and subsequent figures are identified by being enclosed within rectangular boxes.) The second observation is that there does not appear to be significant air saturation in the vicinity of the water table and the nonaqueous-phase liquid (NAPL) smear zone at any of the neutron probe measurement locations. Given the 16-second counting time for the neutron probe measurements, the uncertainty in air saturation measurements is ± 0.05 . Third, elevated air saturations at 5.2 m bgs suggest the presence of a lower-permeability layer above that point. Vertical permeability data from continuous cores are being examined to determine if this is the case.

The electrical resistance data are shown in Figure 26. The details of the air saturation are somewhat different from the neutron probe data; however, the primary features are similar. Specifically, there appears to be no significant air saturation beyond 3 m from the sparge well and the air saturation in the vicinity of the water table is limited. The electrical resistance data do indicate that injected air from the sparge well is reaching the water table in the vicinity of MP-6. The uncertainty in air saturation values using the electrical resistance system is on the order of ± 0.05 .

5.3.5 Tracer Measurements

Tracer measurements were conducted using both helium and sulfur hexafluoride (SF_6). The tracers were used to examine air distribution and recovery by the soil vapor extraction wells of the injected air from the sparge well. The objectives of and results from each of these tracer studies are described in the following sections.

5.3.5.1 Air Distribution Experiments

Air distribution experiments were conducted utilizing SF_6 as a tracer. Experiments were conducted under pulsed and continuous injection of SF_6 . Specific details of these two tracer tests are described in the following sections.

5.3.5.1.1 Pulsed SF_6 Injection Study. A pulsed SF_6 injection study was conducted to obtain information on the extraction flow field. SF_6 was used because it is easily detected in vapor and groundwater samples at very low concentrations, and it has chemical properties not too dissimilar from the properties of oxygen. A known quantity of SF_6 was injected at discrete depth intervals of a multi-level sampler. Extracted off-gas was monitored at each directional soil vapor extraction well

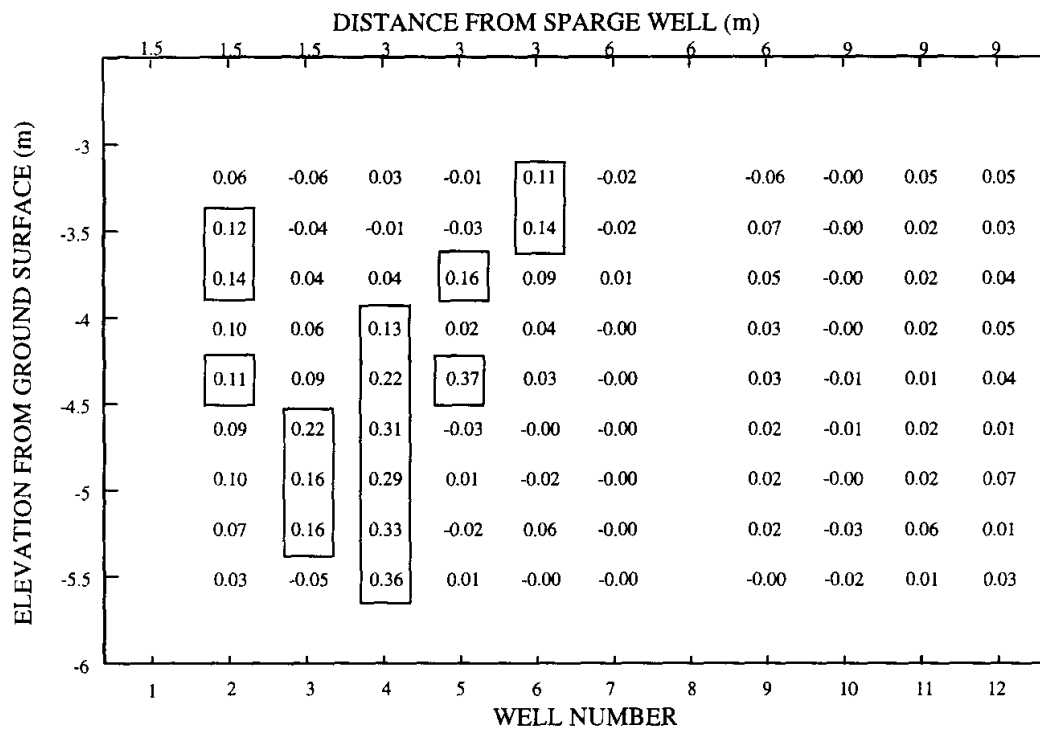

Figure 26. Air Saturation from Electrical Resistance Measurements

for the appearance of SF₆ over time. A sharp pulse is characteristic of injection points located directly within the air flow field. Slower, more diffuse responses are indicative of injection points not well connected to the vapor extraction system.

SF₆ was injected into the following sampling points at the specified volumes: MP1-4.0'—0.5 mL SF₆; MP2-4.0'—1.0 mL SF₆; MP3-4.0'—0.5 mL SF₆; MP4-4.0'—0.5 mL SF₆; MP5-4.0'—0.5 mL SF₆; MP6-4.0'—0.5 mL SF₆; MP6-8.0'—0.5 mL SF₆; MP9-4.0'—0.5 mL SF₆; and sparge well—0.5 mL SF₆. The data set is provided in Appendix E.

Figure 27 presents results from the injection of a pulse of SF₆ vapor into the MP1-4.0' sample location, which is located approximately 10 ft west of the centrally located sparge well. As expected, the directional soil vapor extraction well recovered the majority of SF₆ from this direction. One can also note the longer travel time for the peak to arrive when at MP4, shown in Figure 28, compared to the results in Figure 27.

5.3.5.1.2 Continuous SF₆ Injection Study. In these studies, SF₆ was blended with the air injection stream from the in situ air sparging compressor beginning approximately 24 hours after initiation of air sparging. It was injected continuously at a known mass rate for approximately 24 hours, at which time groundwater samples were collected to assess air distribution within the aquifer. The groundwater samples were collected from the multi-level samplers. The concentration of SF₆ in the injected air was determined in the field. Based on the injection concentration, a theoretical solubility in the groundwater was calculated using a dimensionless Henry's gas constant of 150. Approximately 120 groundwater samples were collected for each of these analyses (i.e., 10 depths at 12 locations).

The concentrations of SF₆ in the groundwater (expressed in percent saturation relative to its concentration in the injected air) are shown in Figure 29. Unlike the neutron probe and electrical resistance data, the SF₆ data do not give a direct measure of air saturation. Instead, the SF₆ data indicate where sparge air has been present in the groundwater zone during the period of its injection. In general, it can be assumed that concentrations near saturation indicate that air pathways were near the sampling point (e.g., within 10 to 20 cm based on the volume of groundwater sampled) and that zero or near-zero percent saturations indicate that air has not been in the vicinity of the sampling point. There are both similarities and differences between the SF₆, neutron probe, and electrical resistance data. The SF₆ data once again indicate that there is no significant influence of the air sparging system at distances of > 3 m from the sparge well. Interestingly, there is one point with

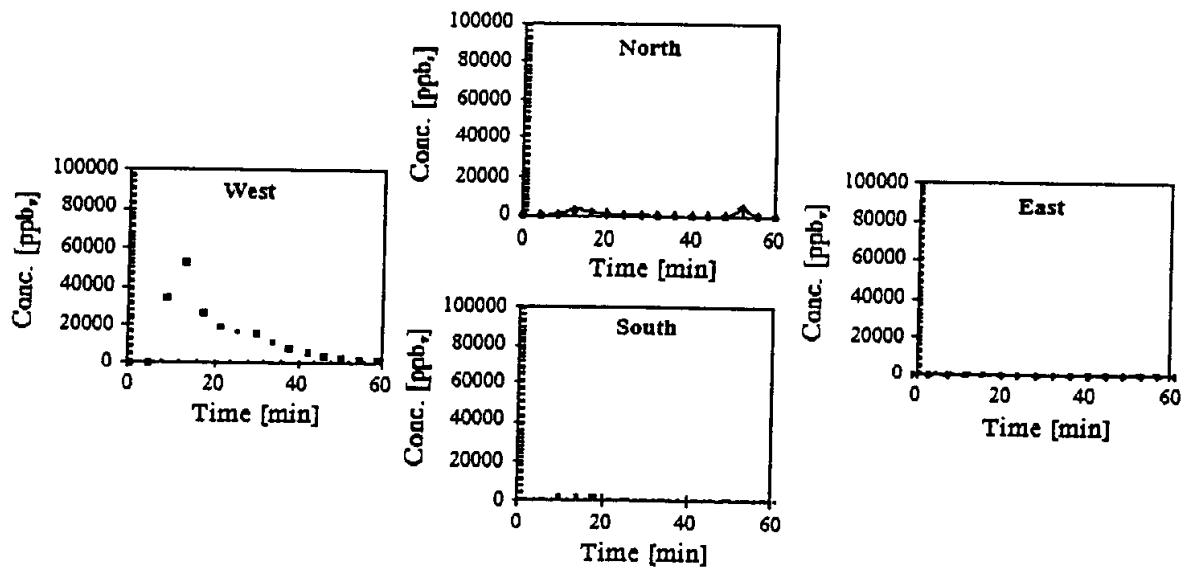

Figure 27. Directional Soil Vapor Extraction Well Response to SF₆ Pulse Injection at MP1-4.0'

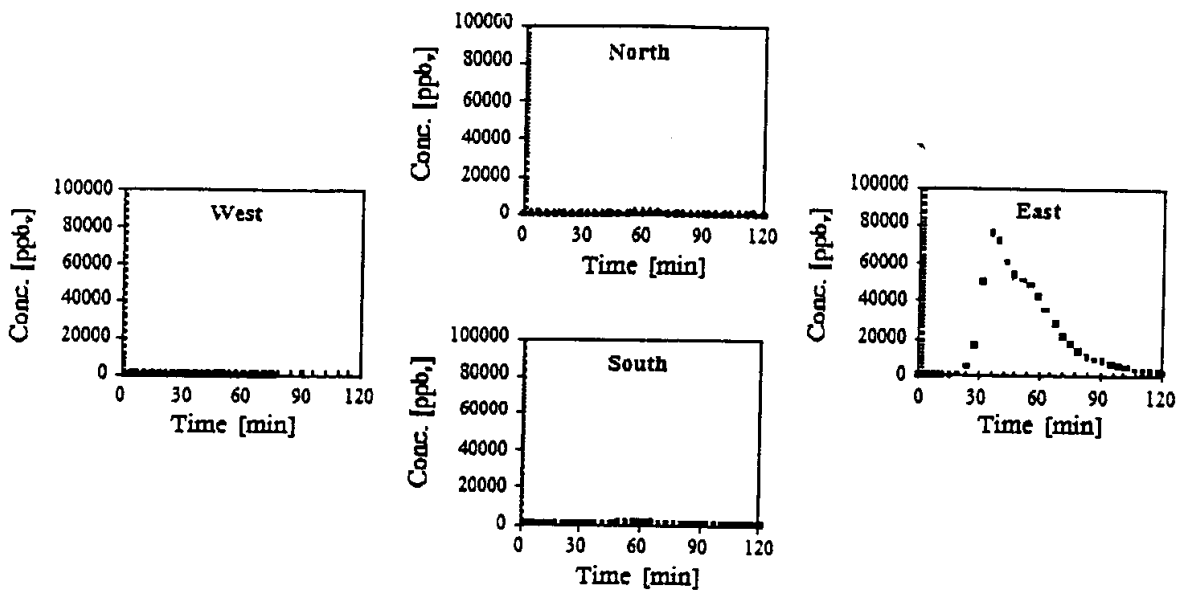

Figure 28. Directional Soil Vapor Extraction Well Response to SF₆ Pulse Injection at MP4-4.0'

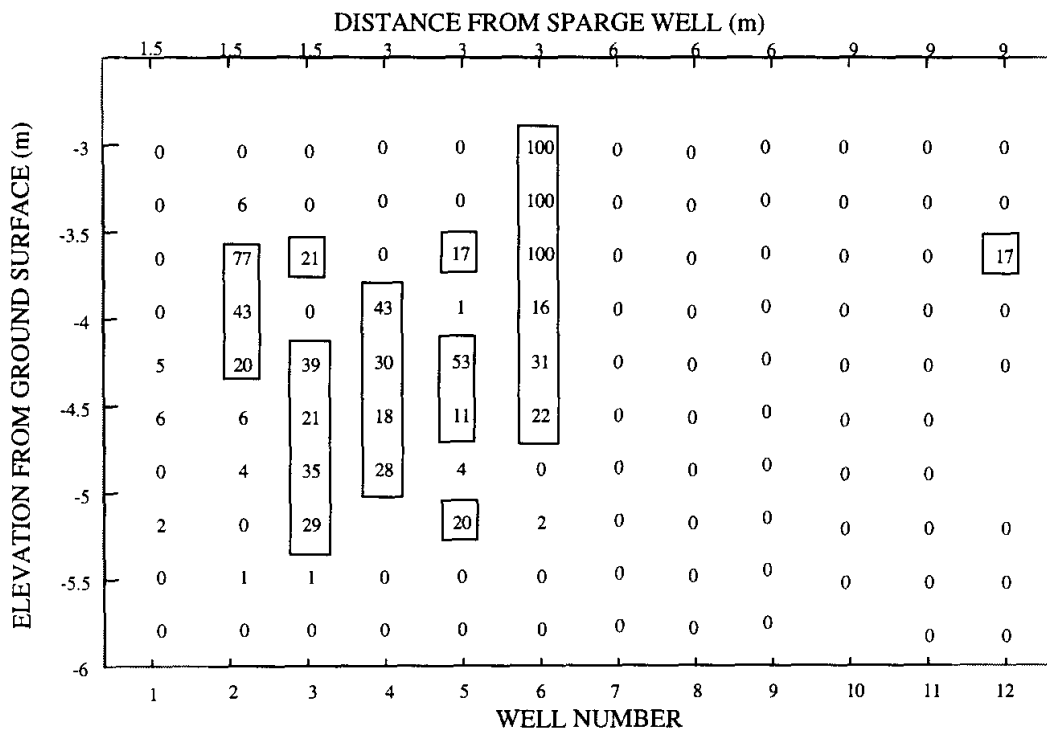

Figure 29. Percent Saturation of SF₆ in Groundwater Relative to Input Concentration

significant SF₆ concentration at MP-12 (30 ft [9.1 m] from the sparge well). Other data confirm that the measurement is correct.

The SF₆ data are perhaps most interesting when compared to the measured dissolved oxygen data (Figure 30). The dissolved oxygen data were collected approximately 24 hours after initiation of air sparging. Because oxygen injection began at air sparging startup, the dissolved oxygen data may reflect the total volume of water that came into contact with the sparge air during the startup phase, as well as once steady conditions had been achieved (approximately 4 to 6 hours based on hydraulic pressure data). Elevated dissolved oxygen values are considerably more widespread than the corresponding SF₆ data¹. This is particularly the case at the 20- and 30-ft distances from the sparge well. In general, the dissolved oxygen data are difficult to interpret given uncertainties in the rates of geochemical and biological reactions and other factors. The SF₆ data are believed to be a better indicator of the distribution of sparge air under steady sparging conditions. The question of SF₆ distribution (as well as air saturations) under pulsed conditions and at higher flow rates will be examined in an upcoming portion of the project.

5.3.5.2 Injected Air Recovery

The efficiency with which the sparge air was recovered by the soil vapor extraction system was determined using a helium recovery test. Helium was injected at a concentration of 28% along with the sparge air. The concentrations of helium in the off-gas were monitored until it stabilized. The percentage of the air recovered was calculated as:

$$\% \text{ Air Recovered} = \frac{\text{SVE airflow}}{\text{Sparging airflow}} \times \frac{\text{Extracted concentration}}{\text{Injected concentration}} \times 100 \quad (1)$$

The data shown in Figure 31 show that approximately 80% of the sparge air appears to be recovered through the soil vapor extraction system. Travel time from injection to extraction indicates most of the air probably reaches the vadose zone on the order of 10 ft from the injection well. The lack of tracer in the initial few minutes after extraction indicates that air is not short-circuiting against or very near the injection well.

¹ All dissolved oxygen values measured prior to initiation of air sparging were less than 10% of saturation.

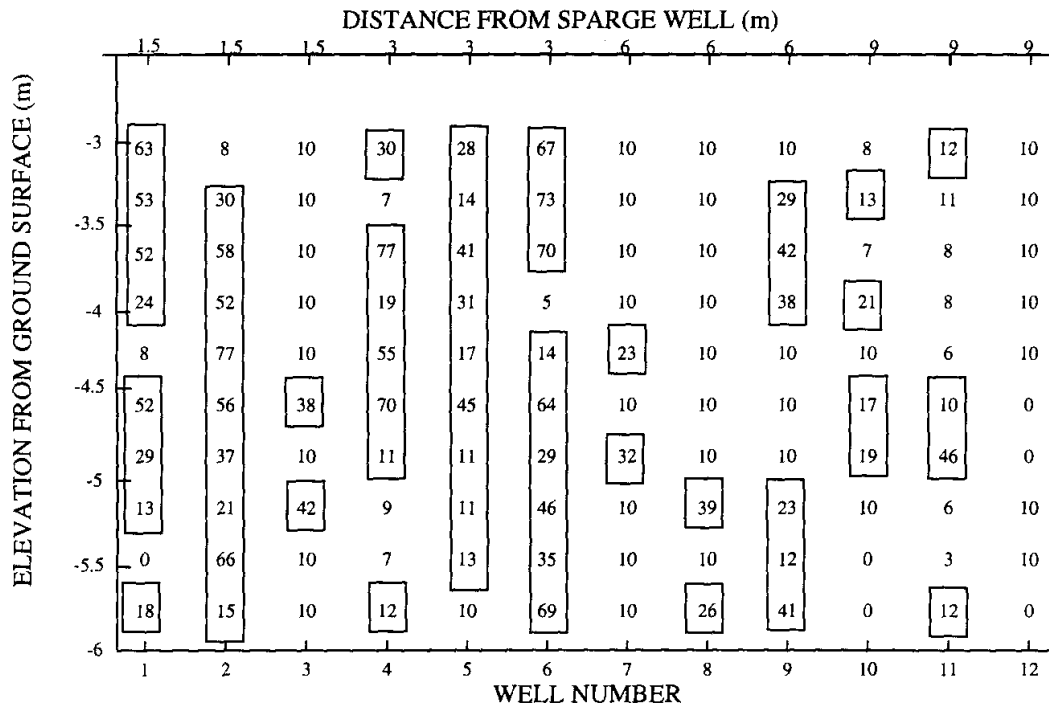

Figure 30. Percent Saturation of Dissolved Oxygen Based on Equilibrium with the Atmosphere

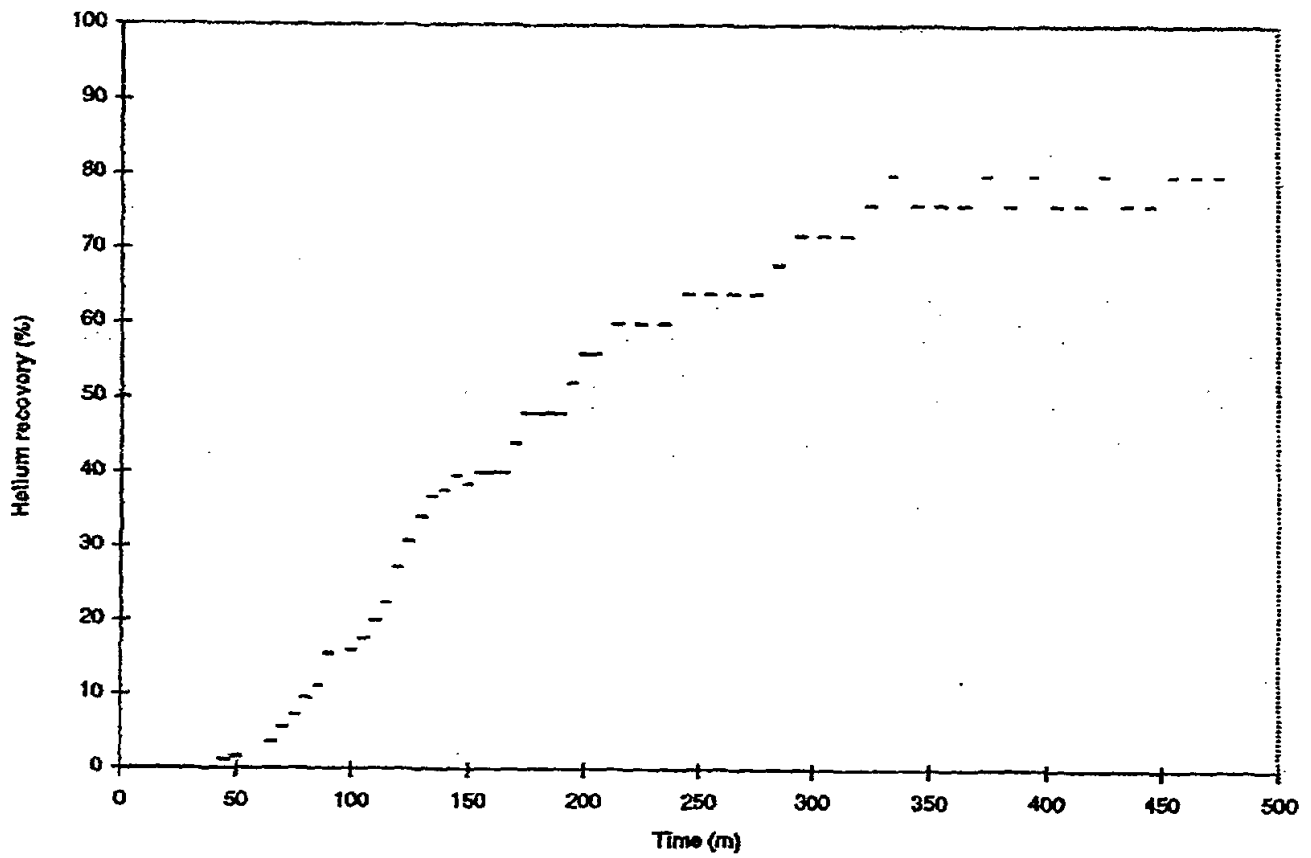

Figure 31. Recovery of Sparge Air in the Soil Vapor Extraction System (Measured as % Helium Recovered)

During the air recovery test, helium concentrations were measured in the vadose zone. Figure 32 shows the concentrations observed at the 8-ft depth. There appears to be a nonsymmetrical distribution of sparge air at the site.

6.0 SUMMARY

Physical model studies have demonstrated that there appears to be an optimal air injection rate. Injection rates above this optimal rate appear to cause decreases in permeability. Studies also show that pulsing the air flow has little effect on oxygen transfer, but does improve volatilization.

Site characterization at the field site demonstrated that the majority of the contamination is within the upper 4 ft of the aquifer. Soil contamination is high in this region at Site 1, the source zone area, whereas soil contaminant concentrations at Site 2, the dissolved-phase area, are nearly all below detection limits.

Data to date have demonstrated that the monitoring system performed well as designed (i.e. air appears to be distributed within the outer ring of monitoring points, and there is little evidence of significant movement of air outside the monitoring system).

Based on tracer testing, virtually all the air injected was captured by the soil vapor extraction system. Travel time from injection to extraction indicates most of the air probably reaches the vadose zone on the order of 10 ft from the injection well. The lack of tracer in the initial few minutes after extraction indicates that air is not short-circuiting against or very near the injection well.

The field geophysical and tracer data collected at the Port Hueneme site generally indicate that under steady sparging conditions there is little air saturation outside of a 3-m radius surrounding the sparge well. The data also indicate that air saturation measurements in the vicinity of the water table (and at this site the NAPL smear zone) are low, indicating that remediation may not be effective in that zone.

The field data were collected within 72 hours following air sparging initiation. There is some evidence suggesting that the air distribution may still have been changing during that time. The measurements described here will be repeated when the air sparging system is restarted and following approximately 3 weeks of continuous operation. Under those conditions, it is anticipated that the air distribution will be steady and should allow the data sets to be compared more directly.

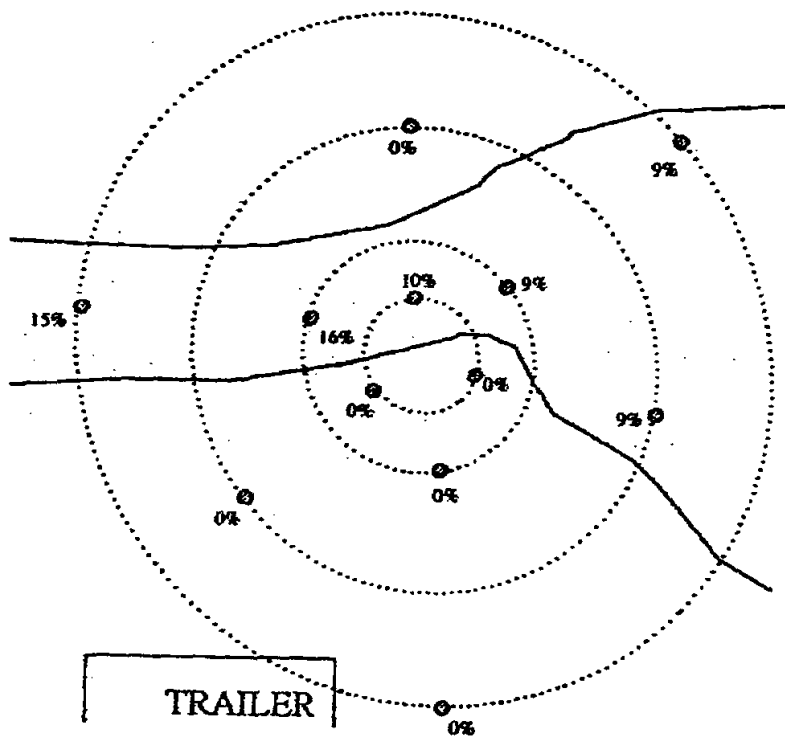

Figure 32. Helium Concentration (%) at a Depth of 8 ft

7.0 REFERENCES

- Ardito, C.P. and J.F. Billings. 1990. "Alternative Remediation Strategies: The Subsurface Volatilization and Ventilation System." In: *Proceedings of Petroleum Hydrocarbons and Organic Chemicals in Ground Water: Prevention, Detection, and Restoration*. October 31 - November 2. Houston, TX.
- Das, A.J. 1996. "Laboratory Scale Study of Volatilization from Residual Source Zones During Air Sparging", Masters Thesis submitted to Arizona State University, Tempe, AZ.
- ERC Environmental and Energy Services Company (ERC). 1989. *Final Report, Predesign Studies at Naval Exchange Gas Station, Naval Construction Battalion Center, Port Hueneme, California*, Report prepared for Naval Energy and Environmental Support Activity, Port Hueneme, California.
- Herrling, B. J. Stamm, E.J. Alesi, G. Bott-Breuning, and S. Diekmann. 1994. "In Situ Bioremediation of Groundwater Containing Hydrocarbons, Pesticides, or Nitrate Using Vertical Circulation Flows." In: *Air Sparging for Site Remediation*. R.E. Hinchee (Ed.) CRC Press, Inc. Boca Raton, Florida.
- Hinchee, R.E., D.C. Downey, R.R. Dupont, P.K. Aggarwal, and R.N. Miller. 1991. "Enhancing Biodegradation of Petroleum Hydrocarbons Through Soil Venting." *Journal of Hazardous Materials*, 27:315-325.
- Johnson, P.C., R.L. Johnson, D.B. McWhorter, R.E. Hinchee, and I. Goodman. 1993. "An Overview of In Situ Air Sparging." *Ground Water Monitoring Review* Fall 1993.
- Johnson, P.C., C.C. Stanley, M.W. Kemblowski, D.L. Byers, and J.D. Colthart. 1990. "A Practical Approach to the Design, Operation, and Monitoring of In Situ Soil-Venting Systems." *Ground Water Monitoring Review* Spring 1990.
- Kram, M.L. and J.E. Edkins. 1993. "Multi-phase, On-site Destruction of Gasoline Contamination Using Internal Combustion Technology Adapted to Practical Site Constraints." Invited Presentation at the Research Coordination & Technology Transfer Conference on Underground Storage Tanks. May 4-6.
- PRC Environmental Management, Inc. and James M. Montgomery, Consulting Engineers. 1991. Comprehensive Long-Term Environmental Action Navy (CLEAN) report to Naval Construction Battalion Center, Port Hueneme, California. Naval Exchange Gasoline Station Final Interim Corrective Action Plan. August.
- PRC Environmental Management, Inc. and James M. Montgomery, Consulting Engineering. 1992. Comprehensive Long-Term Environmental Action Navy (CLEAN) report to Naval Construction Battalion Center, Port Hueneme, California. Naval Exchange Gasoline Station Initial Field Report, Final Draft. January.

PRC Environmental Management, Inc. and Montgomery Watson. 1994a. Comprehensive Long-Term Environmental Action Navy (CLEAN) report to Naval Construction Battalion Center, Port Hueneme, California. Final Corrective Action Plan Naval Exchange Gasoline Station. June.

PRC Environmental Management, Inc. and Montgomery Watson. 1994b. Comprehensive Long-Term Environmental Action Navy (CLEAN) report to Naval Construction Battalion Center, Port Hueneme, California. Naval Exchange Gasoline Station July 1994 Groundwater Monitoring Final Report. September.

Rixey, E.G., P.C. Johnson, G.M. Deeley, D.L. Byers, and I.J. Dortch. 1991. "Mechanisms for the Removal of Residual Hydrocarbons from Soils by Water, Solvent, and Surfactant Flushing. Hydrocarbon Contaminated Soils and Groundwater: Analysis, Fate, Environmental, and Public Health Effects." In: *Remediation*, Vol. II P.T. Kosteki and E.J. Calabrese (Eds.). Lewis Publishers.

Salanitro, J.P. 1993. "The Role of Bioattenuation in the Management of Aromatic Hydrocarbon Plumes in Aquifers." *Ground Water Monitoring Review* Fall 1993.

SCS and Landau Associates. 1985. *Initial Assessment Study of Naval Construction Battalion Center, Port Hueneme, California*, Report prepared for Naval Energy and Environmental Support Activity, NEESA 13-079.

WESTEC Services, Inc. 1986. *Spill Study, Naval Exchange Gasoline Station, Naval Construction Battalion Center, Port Hueneme, California; Volume I, Verification Phase*, Report prepared for Naval Energy and Environmental Support Activity.

WESTEC Services, Inc. and James M. Montgomery, Consulting Engineering, Inc. 1987. *Spill Study of Naval Construction Battalion Center, Port Hueneme, California; Volume III, Feasibility Phase*, Report prepared for Naval Energy and Environmental Support Activity.

WESTEC Services, Inc. and R.L. Stollar and Associates. 1988. *Spill Study, Naval Exchange Gasoline Station, Naval Construction Battalion Center, Port Hueneme, California; Volume II, Characterization Phase*, Report prepared for Naval Energy and Environmental Support Activity.

APPENDIX A

**RESULTS FROM TWO-DIMENSIONAL LABORATORY-SCALE
PHYSICAL MODEL STUDIES: MASTER'S THESIS**

**LABORATORY SCALE STUDY OF VOLATILIZATION FROM
RESIDUAL SOURCE ZONES DURING AIR SPARGING**

AMAR J. DAS



**LABORATORY SCALE STUDY OF VOLATILIZATION FROM RESIDUAL
SOURCE ZONES DURING AIR SPARGING**

by

Amar J. Das

**A Thesis Presented in Partial Fulfillment
of the Requirements for the Degree
Master of Science**

ARIZONA STATE UNIVERSITY

December 1996

LABORATORY SCALE STUDY OF VOLATILIZATION FROM RESIDUAL
SOURCE ZONES DURING AIR SPARGING

by
Amar J. Das

has been approved
December 1996

APPROVED:

Chairperson

Supervisory Committee

ACCEPTED:

Department Chairperson

Dean, Graduate College

ACKNOWLEDGMENT

The author sincerely expresses his appreciation to Dr. Paul Carr Johnson for his advice, support and criticisms throughout the project, without which this work could have never been completed. A special thanks goes to Dr. Lawrence Baker and Dr. Peter Fox for their consent to be in the supervisory committee and also for all their help during the course work.

Cristin Bruce went through the draft and provided valuable input. Illa Amerson and Cristin Bruce also helped in preparing for the oral defense. A number of other fellow graduate students helped in many other ways during the course of this project. Among them are Bashar Alsmadi, Phil Brown, Hari Anandh, Jennifer Campbell, Teresa Kopchynski, Juliet Johnson, Shawn Whitmer, Sara Gerke and Ling-xiao Wang.

Finally, the author would like to appreciate the help of the staff of Civil Engineering Department and ASU's Chemical Store.

This work was funded primarily by the United States Air Force Center for Environmental Excellence (Tyndal AFB), and conducted in collaboration with researchers from Battelle Memorial Institute (Columbus OH), the Oregon Graduate Institute, Colorado State University, and Parsons Engineering Science. Additional financial support was provided by Arizona State University.

ABSTRACT

In the past decade in-situ air sparging (IAS) has found widespread application for the remediation of aquifers impacted by volatile organic compounds (VOCs). Despite the large number of applications and anecdotal performance reports, the underlying phenomena associated with this technology are still not clearly understood. To further increase the potential for successful application, a fundamental understanding of the basic removal mechanisms is needed.

In this work, experiments were conducted in a laboratory-scale physical model, with the hope that the qualitative trends observed in the physical model would be indicative of the qualitative behavior at actual sites. The dependence of in situ air sparging performance on process flow changes and chemical type was studied. The emphasis was placed on the removal of petroleum hydrocarbons from "source zones" containing high concentrations of immiscible-phase liquids. For comparison, experiments were conducted in both water-saturated and water-drained media, which was felt to simulate the conditions encountered during in situ air sparging and soil vapor extraction. All source zone treatment studies were conducted with a homogeneous media composed of 1-mm glass beads. Some other related oxygen transfer studies were conducted in layered media.

Results suggest that initial removal rates are directly proportional to flow rate and saturated vapor concentration; longer-term cumulative removal appears independent of flow rate, but changes with chemical properties. Pulsing the air injection flow rate did cause greater cumulative removal in comparison with steady air injection at comparable time-averaged flow rates.

TABLE OF CONTENTS

	Page
LIST OF TABLES.....	vii
LIST OF FIGURES.....	viii
CHAPTER	
1. INTRODUCTION.....	1
Overview.....	1
Research objectives.....	8
2. CONCEPTUAL MODEL AND THEORETICAL CONSIDERATIONS.....	9
3. METHODOLOGY.....	14
Description of the aquifer model.....	14
Preparation of the aquifer model.....	15
Analytical and monitoring equipment.....	17
Properties of the medium used.....	25
Properties of the chemicals used.....	26
Experimental Procedure.....	27
Preliminary experiments.....	27
Intermediate volatilization experiments.....	27
Final volatilization experiments.....	28
4. RESULTS.....	29
Primary volatilization experiments.....	29
Intermediate volatilization experiments.....	30
Final volatilization experiments.....	40

CHAPTER	Page
Volatilization studies - sources located away from the air flow field.....	41
5. DATA ANALYSIS AND DISCUSSION.....	55
Dry medium octane volatilization experiments.....	57
Wet medium experiments using octane.....	63
Dry medium experiment using n-hexane.....	80
Wet medium experiments with variable air injection rate using n-hexane.....	80
Source located away from the air flowfield.....	86
Sources of error for the experiments.....	86
6. CONCLUSIONS AND RECOMMENDATIONS.....	89
Conclusions.....	89
Recommendations.....	91
REFERENCES.....	94
APPENDIX	
A. OXYGEN MASS TRANSFER STUDIES.....	96

LIST OF TABLES

Table	Page
3.1 Design specifications for the two dimensional physical aquifer model.....	15
3.2 Summary of measurement devices and calibration data.....	18
3.3 Summary of glass beads properties.....	25
3.4 Properties of chemicals used in the experiments.....	26
4.1 Specific attributes of preliminary octane volatilization experiments.....	30
4.2 Specific attributes of intermediate octane volatilization experiments.....	30
4.3 Defining attributes of final volatilization experiments for octane removal..	40
4.4 Defining attributes of volatilization experiments for hexane removal.....	41
4.5 Defining attributes of wet medium experiments with source located away from the air flow field.....	42
5.1 Summary of experiments conducted in this study.....	56
5.2 Summary of key characteristics of selected volatilization experiments.....	77
5.3 Cumulative removal of octane and hexane expressed as percentage of initial mass for both octane and hexane in wet medium under steady and pulsed condition.....	85
A1 Summary of measurement devices and calibration data	98
A2 Moisture content calculations.....	102
A3 Average permeability calculations.....	105
A4 Oxygen mass transfer rate calculations.....	108
A5 Time averaged mass transfer rates.....	109

LIST OF FIGURES

Figure	Page
1.1 Conceptual picture of fate of organic LNAPL liquids after their release.....	2
1.2 Schematic of an air sparging system.....	5
2.1 Conceptual model of processes occurring during in situ air sparging.....	11
2.2 Conceptual model of oxygen and contaminant distributions in the vicinity of an air flow channel.....	12
3.1 Photograph of the two dimensional aquifer physical model used in this work	16
3.2 Experimental flow loop	19
3.3 Result of standard run for octane on different dates.....	21
3.3 Result of standard run for octane on different dates.....	22
3.5 Result of standard run for hexane on different dates.....	23
3.6 Result of standard run for hexane on different dates.....	24
4.1 Octane concentration in the outlet air of the physical model vs. time for $Q_{air} = 11$ L/min steady injection and $M^o = 7.03$ g., preliminary dry medium experiment.....	31
4.2 Octane concentration in the outlet air of the physical model vs. time for $Q_{air} = 11$ L/min steady injection and $M^o = 7.03$ g., preliminary dry medium experiment.....	32
4.3 Octane concentration in the outlet air of the physical model vs. time for $Q_{air} = 11$ L/min steady injection and $M^o = 7.03$ g., preliminary wet medium experiment.....	33
4.4 Octane concentration in the outlet air of the physical model vs. time for $Q_{air} = 1.25$ L/min steady injection and $M^o = 35.14$ g., intermediate dry medium	

Figure	Page
experiment.....	34
4.5 Octane concentration in the outlet air of the physical model vs. time for $Q_{air} = 1.25$ L/min steady injection and $M^o = 35.14$ g., intermediate wet medium experiment.....	35
4.6 Octane concentration in the outlet air of the physical model vs. time for $Q_{air} = 10$ L/min steady injection and $M^o = 35.14$ g., intermediate dry medium experiment.....	36
4.7 Octane concentration in the outlet air of the physical model vs. time for $Q_{air} = 10$ L/min steady injection and $M^o = 35.14$ g., intermediate wet medium experiment.....	37
4.8 Octane concentration in the outlet air of the physical model vs. time for $Q_{air} = 10$ L/min pulsed injection and $M^o = 35.14$ g., intermediate dry medium experiment.....	38
4.9 Octane concentration in the outlet air of the physical model vs. time for $Q_{air} = 10$ L/min pulsed injection and $M^o = 35.14$ g., intermediate wet medium experiment.....	39
4.10 Octane concentration in the outlet air of the physical model vs. time for $Q_{air} = 1.25$ L/min steady injection and $M^o = 35.14$ g., final wet medium experiment.....	43
4.11 Octane concentration in the outlet air of the physical model vs. time for $Q_{air} = 1.25$ L/min steady injection and $M^o = 35.14$ g., final wet medium experiment.....	44
4.12 Octane concentration in the outlet air of the physical model vs. time for $Q_{air} = 10$ L/min steady injection and $M^o = 35.14$ g., final wet	

	medium experiment.....	45
4.13	Octane concentration in the outlet air of the physical model vs. time for $Q_{air} = 10$ L/min steady injection and $M^o = 35.14$ g, final wet medium experiment.....	46
4.14	Octane concentration in the outlet air of the physical model vs. time for $Q_{air} = 10$ L/min steady injection and $M^o = 35.14$ g, final wet medium experiment.....	47
4.15	Octane concentration in the outlet air of the physical model vs. time for $Q_{air} = 10$ L/min pulsed injection and $M^o = 35.14$ g, final wet medium experiment.....	48
4.16	Octane concentration in the outlet air of the physical model vs. time for $Q_{air} = 10$ L/min pulsed injection and $M^o = 35.14$ g, final wet medium experiment.....	49
4.17	Octane concentration in the outlet air of the physical model vs. time for $Q_{air} = 10$ L/min pulsed injection and $M^o = 35.14$ g, final wet medium experiment.....	50
4.18	Hexane concentration in the outlet air of the physical model vs. time for $Q_{air} = 10$ L/min steady injection and $M^o = 35.14$ g, intermediate medium experiment.....	51
4.19	Hexane concentration in the outlet air of the physical model vs. time for $Q_{air} = 10$ L/min steady injection and $M^o = 35.14$ g, final wet medium experiment.....	52
4.20	Hexane concentration in the outlet air of the physical model vs. time for $Q_{air} = 10$ L/min pulsed injection and $M^o = 35.14$ g., final wet	

Figure	Page
medium experiment.....	53
4.21 Octane concentration in the outlet air of the physical model vs. time for $Q_{air} = 10 \text{ L/min}$ & $M^o = 35.14 \text{ g}$, final wet medium experiment.....	54
5.1 Mass removal rate and cumulative octane removal of initial mass vs. time for $Q_{air} = 11 \text{ L/min}$ steady injection and $M^o = 7.03 \text{ g}$, preliminary dry medium experiemnt.....	58
5.2 Mass removal rate and cumulative octane removal of initial mass vs. time for $Q_{air} = 11 \text{ L/min}$ steady injection and $M^o = 7.03 \text{ g}$, preliminary dry medium experiemnt.....	59
5.3 Mass removal rate and cumulative octane removal of initial mass vs. time for $Q_{air} = 1.25 \text{ L/min}$ steady injection and $M^o = 35.14 \text{ g}$, intermediate dry medium experiment.....	60
5.4 Mass removal rate and cumulative octane removal of initial mass vs. time for $Q_{air} = 10 \text{ L/min}$ steady injection and $M^o = 35.14 \text{ g}$, intermediate dry medium experiment.....	61
5.5 Mass removal rate and cumulative octane removal of initial mass vs. time for $Q_{air} = 1.25 \text{ L/min}$ pulsed injection and $M^o = 35.14 \text{ g}$, intermediate dry medium experiment.....	62
5.6 Mass removal rate and cumulative octane removal of initial mass vs. time for $Q_{air} = 1.25 \text{ L/min}$ steady injection and $M^o = 7.03 \text{ g}$, preliminary wet medium experiment.....	65
5.7 Mass removal rate and cumulative octane removal of initial mass vs. time for $Q_{air} = 1.25 \text{ L/min}$ steady injection and $M^o = 35.14 \text{ g}$, intermediate wet medium experiment.....	66

Figure	Page
5.8 Mass removal rate and cumulative octane removal of initial mass vs. time for $Q_{air} = 1.25$ L/min steady injection and $M^o = 35.14$ g., final wet medium experiment.....	67
5.9 Mass removal rate and cumulative octane removal of initial mass vs. time for $Q_{air} = 1.25$ L/min steady injection and $M^o = 35.14$ g., final wet medium experiment.....	68
5.10 Mass removal rate and cumulative octane removal of initial mass vs. time for $Q_{air} = 10$ L/min steady injection and $M^o = 35.14$ g, intermediate wet medium experiment.....	69
5.11 Mass removal rate and cumulative octane removal of initial mass vs. time for $Q_{air} = 10$ L/min steady injection and $M^o = 35.14$ g, intermediate wet medium experiment.....	70
5.12 Mass removal rate and cumulative octane removal of initial mass vs. time for $Q_{air} = 10$ L/min steady injection and $M^o = 35.14$ g, final wet medium experiment.....	71
5.13 Mass removal rate and cumulative octane removal of initial mass vs. time for $Q_{air} = 10$ L/min steady injection and $M^o = 35.14$ g., final wet medium experiment.....	72
5.14 Mass removal rate and cumulative octane removal of initial mass vs. time for $Q_{air} = 10$ L/min pulsed injection and $M^o = 35.14$ g, intermediate wet medium experiment.....	73
5.15 Mass removal rate and cumulative octane removal of initial mass vs. time for $Q_{air} = 10$ L/min pulsed injection and $M^o = 35.14$ g., final wet medium experiment.....	74

Figure	Page
5.16 Mass removal rate and cumulative octane removal of initial mass vs. time for $Q_{air} = 10$ L/min pulsed injection and $M^o = 35.14$ g, final wet medium experiment.....	75
5.17 Mass removal rate and cumulative octane removal of initial mass vs. time for $Q_{air} = 10$ L/min pulsed injection and $M^o = 35.14$ g, final wet medium experiment.....	76
5.18 A close look at the short term removal rate of octane vs. time for $Q_{air} = 1.25$ L/min steady injection and $M^o = 35.14$ g	78
5.19 A close look at the short term removal rate of octane vs. time for $Q_{air} = 10$ L/min steady injection and $M^o = 35.14$ g	79
5.20 Mass removal rate and cumulative hexane removal of initial mass vs. time for $Q_{air} = 10$ L/min steady injection and $M^o = 33$ g., intermediate dry medium experiment.....	81
5.21 Mass removal rate and cumulative hexane removal of initial mass vs. time for $Q_{air} = 10$ L/min steady injection and $M^o = 33$ g., final wet medium experiment.....	82
5.22 Mass removal rate and cumulative hexane removal of initial mass vs. time for $Q_{air} = 10$ L/min pulsed injection and $M^o = 33$ g, final wet medium experiment.....	83
5.23 Mass unaccounted for in the final mass balance vs. time.....	84
5.24 Mass removal rate & cumulative octane removal of initial mass vs. time for $Q_{air} = 10$ L/min both steady injection and pulsed injection and $M^o = 35.14$ g.....	87
A1 Layered setting for the physical model shown with typical air flow field...	98

A2	Experimental flow loop.....	99
A3	Moisture retention curve for 0.11 mm diameter glass beads.....	103
A4	Average permeability to water vs. air injection rate for layered system.....	106
A5	Oxygen mass transfer rate vs. time for constant water flowrate (270 cm ³ /min) and variable air injection rate for a layered system.....	111
A6	Time averaged oxygen mass transfer rate vs. time for constant air injection (7 L/min) and no water circulation in a layered system.....	112

CHAPTER 1

INTRODUCTION

Overview

Accidental releases or spills of liquid petroleum products or industrial solvents from leaking storage tanks, pipelines, tanker trucks, etc. can introduce liquids containing volatile organic compounds (VOCs) to subsurface soils and groundwater. Once released these liquids move downward and laterally through soils under the influence of gravity, and capillary forces. In the case of smaller releases and when there is an appreciable depth of unsaturated zone, liquid penetration may be limited to subsurface soils only. In the case of larger releases, the spilled liquids may finally reach the groundwater table. Liquids with densities greater than that of water (DNAPLs - dense non-aqueous phase liquids) will penetrate and continue to move down through aquifers. Lesser density liquids (light non-aqueous phase liquids, LNAPLs), on the other hand, will pool and spread out on top of the capillary fringe above the water table. LNAPLs can also be found trapped within aquifers if there has been vertical movement of the groundwater table as a result of either seasonal fluctuations or human activities such as pumping (R. Johnson 1994). Contact between the organic liquids and groundwater, or leaching to the water table will result in a dissolved phase groundwater "plume". Figure 1.1 is a schematic of typical LNAPL distributions in the subsurface with and without groundwater fluctuations.

Impacts associated with uncontrolled, or unmitigated, releases of organic liquids are a major concern with respect to their possible impact to resources and human health. It is well established that a

number of VOCs are possible human carcinogens (e.g., benzene and trichloroethylene). As groundwater is a major source of drinking water for a vast majority of people, a pristine water source is highly desirable. Over the years, governments of various nations have developed policies that establish health-protective concentrations of various organic and inorganic compounds in groundwater. For example, in the United States (US), the Safe Drinking Water Act established Maximum Contaminant Levels (MCLs) for drinking water, and these are enforceable by law. Any public water supplier has to treat the groundwater if it does not comply with these standards. These same criteria have been adopted as aquifer remediation standards in many states.

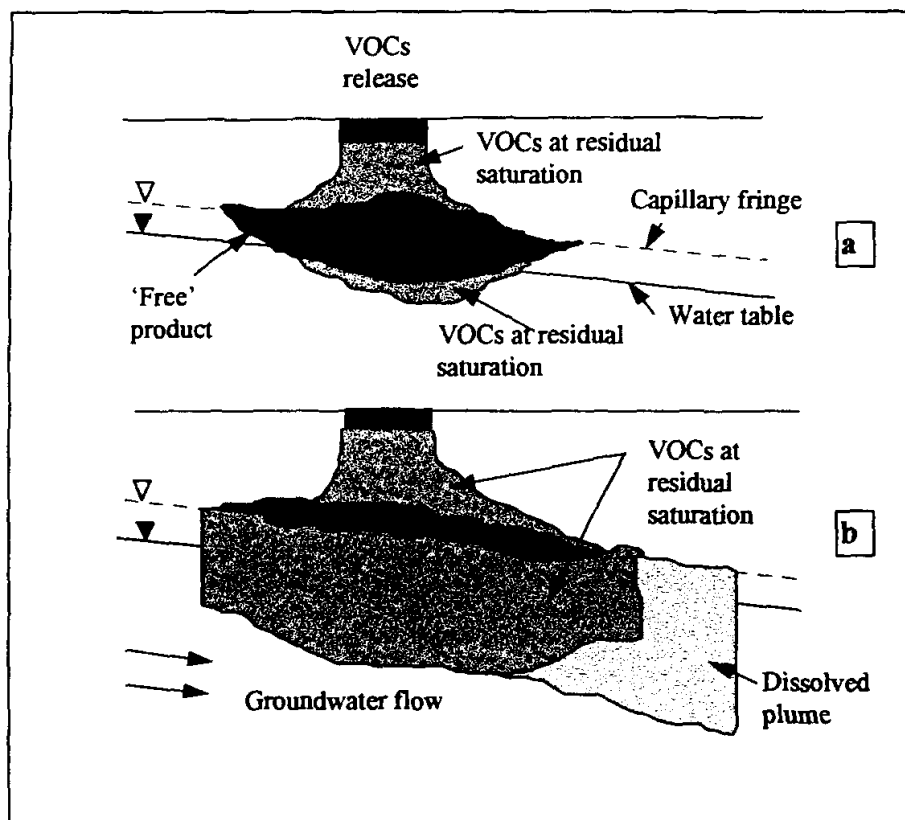

Figure 1.1: Conceptual picture of fate of organic LNAPL liquids after their release. (a) liquid seeps downwards and reaches the groundwater table where it pools and spreads laterally; (b) effect of groundwater movement and groundwater table rise on liquid distribution in subsurface.

To meet these goals, many aquifer cleanup technologies have been proposed and are in various stages of development and application. Most provide slow or limited cleanup and most are considered to be not cost-effective. New efforts are underway to develop better technologies. Below, a brief review of the more common technologies is presented.

Historically, "pump and treat" is the most widely used technology for aquifer remediation. Here groundwater is pumped from wells to ground surface where it is treated by air stripping, activated carbon adsorption, or other above-ground water treatment processes. Treated water then may be reinjected or discharged to a sewer. The benefit of this method is that it can be used to hydraulically contain the dissolved contaminant plume and prevent further downgradient migration.

Over the years, various authors have pointed out the limitations of pump and treat technology (Hinchee 1994, Loden 1992). These include low removal rates due to the limited solubility of many contaminants, limited oxygen solubility for bioremediation, and mass transfer limitations within a heterogeneous geology. Thus, pump and treat technology is very slow (except in cases of very soluble chemicals and permeable aquifers) and not likely to achieve remediation goals within practical time frames. Predicted clean-up times are often >30 years. Long cleanup time increases the cost of extraction, water treatment and monitoring (Loden 1992).

Another prominent technology is soil vapor extraction (SVE) in which contaminant vapors are removed from the vadose (unsaturated) zone by applying a vacuum to wells screened through a portion of the vadose zone. The vacuum induces vapor flow through the soil to the well. Vapors are then treated above-ground before releasing them to the atmosphere. A primary limitation of this technology is that it can not remediate contaminants in the saturated zone, unless the area is first dewatered.

Bioventing is another in situ remediation process that evolved from the early soil vapor extraction studies. Thus, the physical equipment used in a bioventing process design is similar in many ways to the components of soil vapor extractions. The difference, however, is in operating philosophy. Bioventing practitioners attempt to optimize aerobic biodegradation while minimizing removal by volatilization (Miller et al. 1993), while a soil vapor extraction system is designed to maximize removal by volatilization. Often a bioventing system will utilize air injection rather than extraction. In both cases, some degree of volatilization and aerobic biodegradation occurs. US Air Force studies have shown that in some situations bioventing is more economically attractive than conventional soil vapor extraction as the need for off-gas vapor treatment is eliminated and operating costs are reduced. Removal rates in the range 2 - 20 mg-hydrocarbon/kg-soil/d have been measured at many jet fuel spill remediation sites.

Natural attenuation refers to the containment or reduction of groundwater and soil contaminant concentrations with time as a result of biodegradation, adsorption and chemical transformation (McAllister and Chiang 1994). Natural attenuation is a "passive" remediation process, which has shown to be cost-effective for containing dissolved plumes of mono-aromatic compounds. Based on experience and empirical evidence, it is not expected to be effective at source removal, and the projected cleanup time may be very long and uncertain.

Air sparging, which is the focus of this thesis, is an emerging technology that promises efficient and cost-effective removal of wide variety VOCs and degradable contaminants. Air sparging involves the injection of air (or other vapors) into contaminated aquifers to "(1) treat contaminant source areas trapped within water-saturated and capillary zones, (2) remediate dissolved contaminant plumes, or (3) provide barriers to dissolved contaminant plume migration" (Johnson et al. 1995). It is usually used in conjunction with SVE, where contaminant vapors liberated by the injected air are collected and treated by an SVE system. Figure 1.2 shows a conceptual picture of an air sparging system. Air sparging decontaminates aquifers in situ. The primary mechanisms responsible for the contaminant removal are

volatilization and biodegradation. Mass transfer occurs between the vapor/air and water; contaminant vapors enter the moving gas stream while oxygen dissolves into the groundwater. At this point in time it is premature to call it the best possible technology for groundwater VOCs removal; however, it can be argued to be the "least worst" technology in comparison with the other existing technologies.

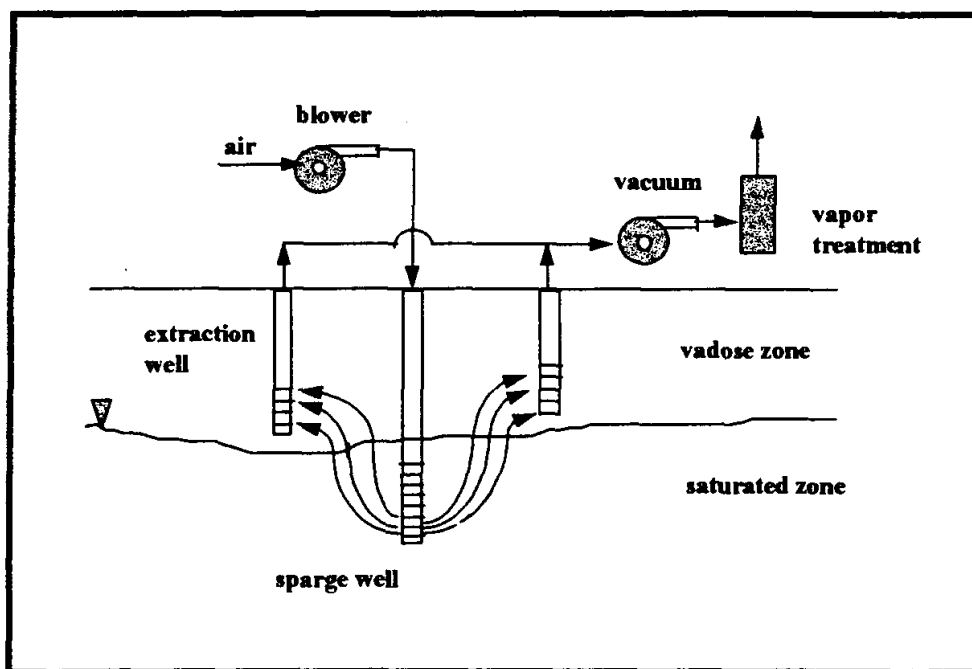

Figure 1.2: Schematic of an air sparging system.

Two potential risks associated with air sparging have been identified: off-site vapor migration and possible contaminant spreading due to a transient rise in the water table (Hinchee 1994, Johnson et al 1993). The first risk can be obviated by using SVE in tandem with air sparging. Groundwater mounding has been established to be a minor concern and is not an issue at steady-state (Lundegard ???). R. Johnson et al. (1994) showed that limited groundwater movement occurred around the sparge well during IAS startup and shutdown, but the magnitude of this groundwater movement decreases significantly as the system approaches steady-state. In summary, these risks can be minimized for

properly designed air-sparging systems.

Mass removal trend data, under both experimental and field conditions, for most in situ remedial processes is rare. Thus we must often resort to the review of anecdotal data from field applications.

Several reported applications of IAS are summarized below.

The first reported IAS use may be extended to Hiller and Gudemann in Europe (1988). In the US, air sparging has been used in many sites and its application was reported in 1990 by Johnson et al. at a service station site. It was demonstrated at a US Department of Energy site (Kabek et al 1991) as an innovative remedial technology for remediating unsaturated zone soils and groundwater containing TCE and PCE. Two horizontal wells were introduced in the subsurface - one in the vadose zone and the other in the saturated zone. The deeper well was used to inject air into the groundwater. A vacuum was applied to the shallower well. The 300-ft long injection well was installed at a depth of 150 - 175 ft. The 200-ft long extraction well was installed at a depth of 75 ft (approximately 65 ft above the groundwater table). Three different air flowrates at two different temperatures were used. Helium tracer tests were conducted for better understanding of the vapor flow paths and soil heterogeneity between the two wells. The results indicated connectivity of vapor flow between the two wells. Results for microbial tests showed an increase in microbial densities by at least an order of magnitude during the air injection period. The entire demonstration was continued for 20 weeks, five of which were vapor extraction only. Extraction rates of VOCs during vapor extraction only regimes averaged 100 pounds of solvents per day. An approximately 20% increase in removal rate was observed when air injection was initiated.

Brown (1991) presented some remediation data from a field implementation of air sparging. The site was contaminated with dry cleaning solvents which resulted from an underground storage tank (UST) leak at a dry cleaning facility. Primary groundwater contaminants were perchloroethylene (PCE), trichloroethylene (TCE), dichloroethylene (DCE) and total petroleum hydrocarbons (TPH). The site was

first exposed to vapor extraction only. After about one month when the total VOC concentration dropped, air sparging in conjunction with SVE was introduced. Groundwater samples were tested after 54 and 125 days of air sparging operation. Results from these tests indicated 98% overall reduction in VOCs (TCE, PCE & DCE) level after introduction of air sparging. It was concluded that air sparging system can be effective in significantly reducing groundwater and soil contamination. Vent effluent samples were collected in tedlar bags and were analyzed in the laboratory. The tedlar bag results show maximum mass removal rates within the first few days.

Air sparging was also used at the conservancy site, Belen, New Mexico (Loden, 1992), where 6,500 gal of gasoline leaked from an underground storage tank. The gasoline seeped through the soil and finally reached the groundwater. The groundwater benzene concentration was as high as 6 mg/L and 33 inches of free product were detected on groundwater in monitoring wells. The soil was silty sand with a clay layer. A network of sparge and extraction well were radially installed around the source of contamination. The system operated for five months. After that period average reduction in the sum of dissolved benzene, toluene, ethylbenzene, and xylene (BTEX) concentrations ranged between 49% to 66%.

Few attempts have been made to model air sparging performance, and these have been hindered by the lack of data collected under well-characterized or controlled settings. Ji (1994) developed a numerical model for mass transfer occurring during air sparging in 1994. In his PhD dissertation he provided numerical simulations of the remediation process of a hypothetical TCE contaminated site by air sparging. The hypothetical site considered was an unconfined aquifer that is 20-m long, 16-m wide and 3-m deep. He then divided the site into 30 layers of equal thickness. The site was isotropic in the horizontal direction with $K_x = K_y$, $K_z = 2/3 K_x$. Uniform TCE concentration distributions of 11 mg/L was assumed for the site. Numerical simulations show that in the presence of air sparging, the total mass

of TCE declined significantly within the first few days.

Research Objectives

Though many field experiments suggest success for air sparging as a mean of removing and degrading contaminants, the mechanisms responsible for the removal are still not clearly understood. This prevents the development of both conceptual and predictive models for air sparging. This thesis reports on experiments that were conducted to better understand the mechanisms controlling in situ air sparging systems. The primary objective of this research is to study the volatilization of residual hydrocarbons during in-situ air sparging (IAS) applied to "source zones". The dependence of volatilization rate on air injection rate, water saturation, pulsing air injection and chemical type was studied in this work. A two dimensional physical-aquifer model was used for the study. The goal was to identify a qualitative trends for VOCs removal, which can help better understand and estimate the contaminant removal process under different conditions such as changes in air injection rate, changes in chemical properties, and the effects of pulsing the air injection. This work is complimentary to the studies conducted by Rutherford (1995) to identify factors controlling oxygen mass transfer during in situ air sparging.

CHAPTER 2

CONCEPTUAL MODEL AND THEORETICAL CONSIDERATIONS

The goal of this work is not to develop new theories or predictive models of in situ air sparging behavior. Instead, the goal is to collect data under well controlled conditions that can be used to guide future theoretical developments. Having said this, however, it is important to propose and discuss a conceptual model for the processes and mechanisms controlling the behavior of in situ air sparging systems. This conceptual model and its implications can then later be compared and refined with observations from the experiments conducted in this research. The refined conceptual model can then serve as a starting point for future theoretical analyses.

Contaminants in porous media may be found dissolved in soil moisture and groundwater, sorbed onto soils, volatilized into any vapor space, and if concentrations are high enough - present as globules of immiscible non-aqueous-phase liquid (NAPL) (Johnson et al. 1993). As stated earlier, in situ air sparging systems may be installed to remediate source zone areas or dissolved plumes, or may be used as contaminant migration barriers. In the case of source zone treatment, the majority of contaminant mass will be found in the immiscible phase. In the case of groundwater plume remediation, contaminants will primarily be found dissolved in groundwater and sorbed to soil particles. In this work we focus on the application of in situ air sparging to source zones, thus we can imagine contaminants initially distributed through some area of the aquifer, with globules of immiscible phase liquids found held between soil particles by capillary forces.

As air is injected into an aquifer, it rises due to buoyancy effects, and spreads due to capillary properties and flow characteristics of the media. Ji et al. (1993) conducted small-scale flow visualization experiments to study air flow distributions around an air injection point. In summary, this work showed that air is most likely to flow through the aquifer in a network of channels, rather than as distinct bubbles (as long as the soil particle size was <2 mm in diameter). The density of channels could be increased by increasing the air flow rate, but the lateral extent was much less sensitive to air injection rate. They also observed that small changes in soil structure could cause significant changes in air distributions, and that small permeability contrasts in adjacent soil layers could cause stratification of the air flow. In addition, air channel number and location appeared to be relatively constant with time, and repeat experiments yielded what appeared to be similar air flow distributions; although, the exact locations and numbers of air channels were not recorded. The observations of Ji et al. are consistent with observations of air flow distributions from the studies reported in this thesis.

Given the discussion above, we can begin to develop our conceptual model. At the macroscopic level we envision an aquifer with some initial distribution of contaminants, and into this aquifer we inject air. The air then forms a network of distinct channels that is defined by properties of the medium, and are rarely expected to be distributed uniformly throughout the aquifer. For steady air injection, the air distribution network reaches a stable configuration that does not change with time. It is also envisioned that the air injection does not induce significant redistribution of the contaminants.

With this rather simplistic macroscopic conceptual model, we can easily argue that in situ air sparging promotes remediation by a combination of volatilization and biodegradation mechanisms. The air flow through the aquifer strips contaminants from the aquifer and also provides a source of oxygen for aerobic biodegradation (note that other gases can be injected to promote the degradation of compounds not easily aerobically biodegraded). As discussed earlier, this study concentrates on the removal of contaminants from source zones by volatilization; readers are referred to the work of Rutherford (1995)

for the results of complimentary laboratory-scale oxygen mass transfer rate studies.

On the microscale we can develop a conceptual model of processes occurring in the vicinity of a single air channel. As shown in Figure 2.1 contaminants may be found within the air flow channel, or in the adjacent water saturated zone. Where contaminants lie within an air flow channel, we anticipate their removal to be similar to that which occurs during soil vapor extraction and bioventing. We also anticipate that contaminants within air flow channels are removed first (either by volatilization or biodegradation), before significant removal of contaminants in the adjacent water-saturated zones occurs. Thus, in the case of a single contaminant, one could argue that removal rates will be greatest at the beginning of an air sparging application, that they will initially be roughly proportional to air injection rate for many operating conditions, and that removal by volatilization in this first phase should be proportional to the contaminants vapor pressure and molecular weight.

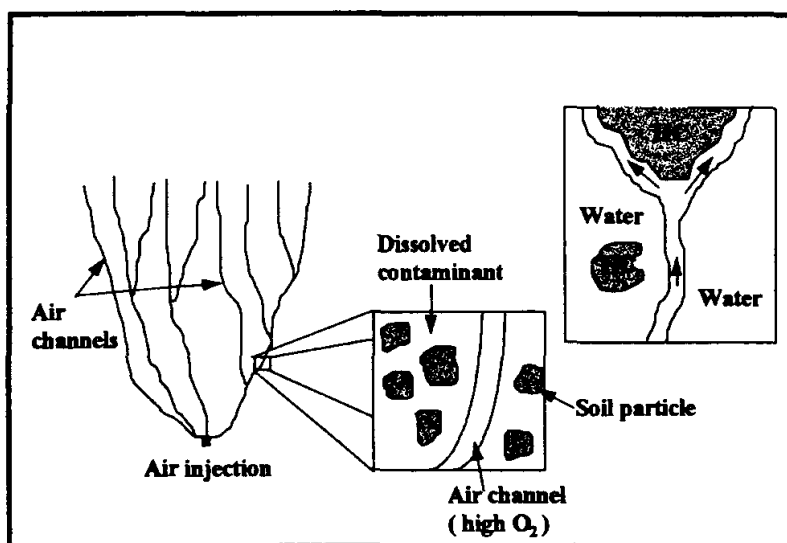

Figure 2.1: Conceptual model of processes occurring during in situ air sparging (after Rutherford 1995).

Contaminants distributed in water-saturated zones adjacent to the air channels are not expected to be as easily removed. In the experiments of Rutherford (1995), oxygen mass transfer rates into

groundwater were shown to be diffusion-limited for conditions representative of many natural groundwater flow systems (specific discharge < 1 m/d). Those experiments, however, were conducted under non-reactive conditions, and it can be reasonably argued that oxygen mass transfer should increase under reactive conditions.

Numerical examples show that the air saturation must be greater than 0.1% and the size of the air channels must be on the order of 0.001 meter in order for air sparging to be successful (Mohr 1995). Hence the effectiveness depends upon the density and size of the air channels. Increasing the density of the air channels increases the interfacial area between air and water phases and decreases the average distance that contaminants must migrate to reach the water channels.

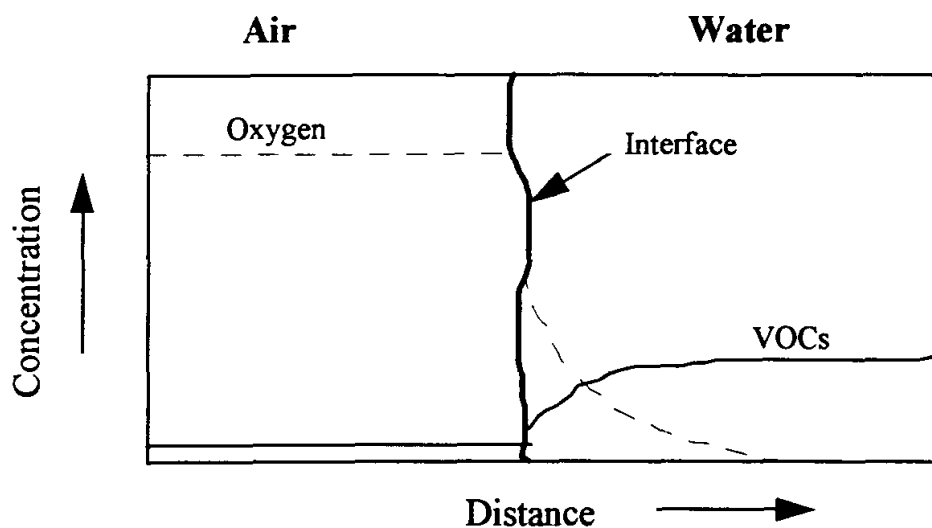

Figure 2.2: Conceptual model of oxygen and contaminant distributions in the vicinity of an air flow channel.

Figure 2.2 presents the expected distribution of oxygen and contaminants as one moves away from an air flow channel, assuming low oxygen/hydrocarbon consumption rates. Injected air will contain roughly 21% oxygen and 0% contaminant vapors. Prior to air injection, dissolved oxygen levels in groundwater surrounding the source zone typically are less than 2 mg/L. Thus, there will be a

concentration gradient for both oxygen and hydrocarbon between the air flow channel/groundwater interface and the water-saturated zone. As the diffusion coefficient of any compound in air is four to five orders of magnitude greater than the corresponding value in water, diffusion through groundwater to the interface will become the limiting process in the absence of significant advective water flow towards the air flow channel. Also, if the removal by volatilization becomes diffusion-limited, and in the absence of mixing, mass removal rates by volatilization would be expected to decrease with time.

One implication of this conceptual model is that the long-term mass removal rates and cumulative removal would be controlled by solubility more than by those chemical properties most often associated with volatilization (e.g., vapor pressure and Henry's Law Constant).

In summary, this section has presented macro- and micro-scale conceptual models that can be used to guide our interpretation and analysis of experimental results. It has been argued that short term removal rates and cumulative removal during air sparging are expected to be controlled by the air flow channel distribution, the air injection rate, and the molecular weight and vapor pressure of the contaminants present. Long-term performance should then become controlled by the air flow channel distribution, should be independent of air injection rate (under most conditions), and should be dependent most strongly on compound solubility.

CHAPTER 3

METHODOLOGY

Description of the aquifer model

The two-dimensional aquifer physical model used in this work has been described previously by Rutherford (1995). It is 244-cm (8 ft) long, 122-cm (4 ft) tall and 5.08-cm (2 in) wide. The faces are built from 1.91-cm (3/4 in) Plexiglas with the ends and bottoms being built from 2.54-cm (1 in) Plexiglas. Plexiglas slots are glued on the inside of the faces to create 2.54-cm (1 in) wide clear wells at either end of the physical model. These act as flow distributors. Reinforced aluminum screens are inserted in these slots to prevent movement of the porous medium into the clear wells. The removable tank lid is constructed from 1.91-cm (3/4 in) Plexiglas. The lid has six 1.91-cm (3/4 in) diameter NPT holes which can be used as gas exit ports. Eighteen bolts and numerous C-clamps are used to hold and seal the lid to the tank. A 0.53-cm [0.211-in] silicon cord, placed between the tank and the lid, is used to achieve an air-tight seal when the tank lid is bolted and clamped. 1.91-cm (3/4 in) NPT holes are located at 15.24-cm [6-in] intervals across the side. Aluminum plates with 3.81-cm [1.5 in] holes and stainless steel expanded metal sit on the top of the granular media and are compressed by five 30.48-cm [12 in] long bolts screwed through the lid to maintain an overburden on the medium. The physical model bottom has a 1.91-cm (3/4 in) diameter air injection port at its center point. Two other identical ports equidistant to either side of the air injection port serve as drains. Two Type "J" Omega thermocouples are inserted

into the porous medium through 20.54-cm [10 in] long stainless steel tubes located at each end of the physical model. A Unistrut frame mounted to the wall holds the tank in place and maintains compression of the faces of the tank. The physical model is placed over an aluminum catch basin.

Figure 3.1 presents a photograph of the experimental physical model as configured for this work.

The design specifications for the physical model are summarized in Table 3.1

Table 3.1: Design specifications for the two-dimensional aquifer physical model (Rutherford 1995).

Parameter	Metric Units [cm]	English Units [in]
Length of the tank	244	96
Height of the tank	122	48
Width of the tank	5.08	2
Number of perimeter ports	14 sides, 8 bottom	
Diameter of perimeter ports	1.905	3/4
Diameter of top vent ports	5.08	2
Plexiglas thickness for sides	1.905	3/4
Plexiglas thickness for ends	2.54	1
Internal volume	150.9 L	5.33 ft ³
Clear well volume		
Total soil volume	138.8 L	4.9 ft ³
Support frame material	Unistrut P - 1000	
Type of "O" ring	0.139 Buna for tank / 0.21 silicon for lid	0.353 Buna for tank / 0.53 silicon for lid

Preparation of the Aquifer Model

The aquifer model was packed with 1-mm diameter uniform spherical glass beads (Jaygo).

When placing the glass beads in the tank the lid is first removed and enough dry beads are poured to form less than 2.5-cm (1 in) thick layers. As each successive layer is poured, a square tube aluminum tamper

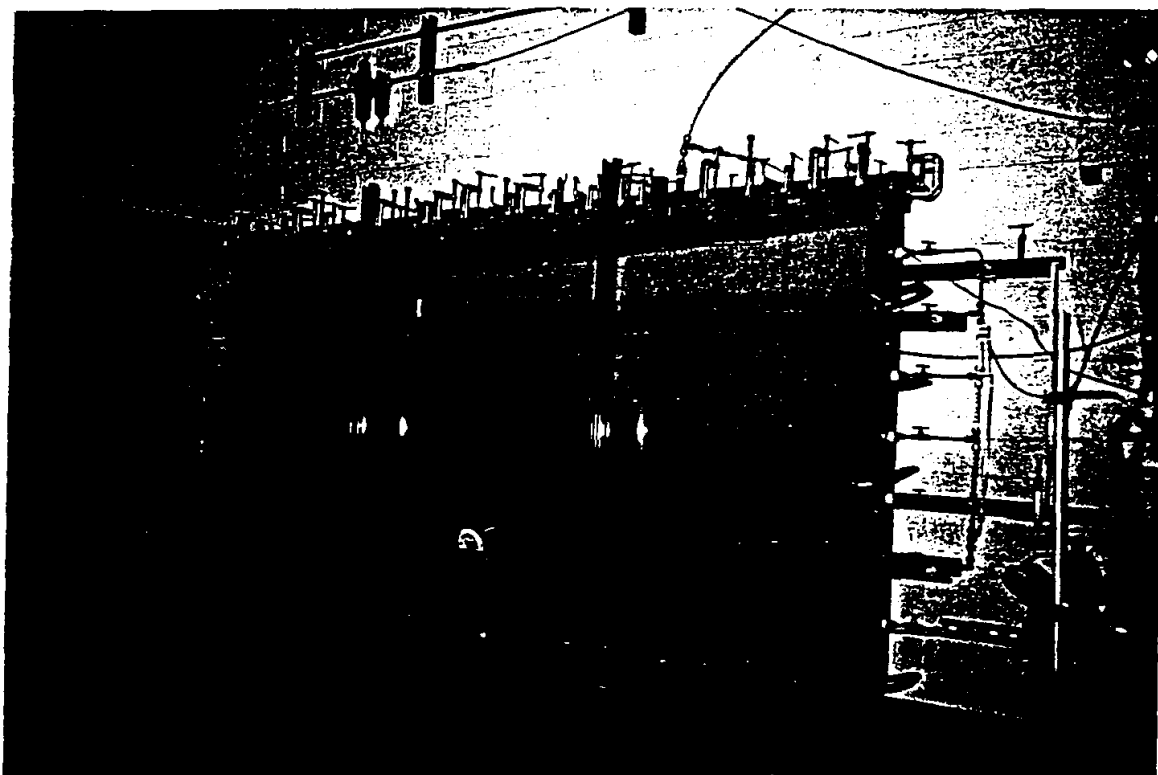

Figure 3.1. Photograph of the two-dimensional aquifer physical model used in this work

is used to compress the medium (usually using five blows per location). The tank is usually filled with glass beads to a height of 117 cm [46 in]. The effective soil section length (between clear wells) was 239 cm [94 in]. Bulging of the tank will occur if not limited by the external unistrut frame which applies pressure across the faces of the tank. As mentioned above, the soil column was compressed and held in position by reinforced aluminum screens on the two ends and aluminum and expanded metal on the top. These help to minimize preferential air paths in the medium and along the walls. Wall effects are not expected to be significant since the lateral dimension of the tank far exceeds 10 times the particle diameter (5.08 cm \gg 10 x 1 mm).

Between experiments and whenever recompaction is desired, water in the tank is drained and then the glass beads are removed with a commercial wet/dry vacuum. Water is introduced slowly into the model from the bottom in order to minimize air entrapment in the medium.

Analytical and Monitoring Equipment

Various analytical and monitoring equipment are used in these experiments; these are summarized in Table 3.2 and Figure 3.2.

Air from a facility compressed air supply line, is connected to a port located at the bottom of the physical model. A flow meter (rotameter) and pressure regulator are used to measure and regulate the influent air stream. Most of the outlet air from the physical model flows directly to a flow meter and then

Table 3.2: Summary of measurement devices and calibration data.

Measurements	Devices	Scale/Precision
Air flowrate	Dwyer RMA Ratemaster	2-20 x 100 ± 4 cm ³ /min air
Air flowrate	Dwyer RMA Ratemaster	0 - 5 ± 0.2 L/min air
Air flowrate	Dwyer RMA Ratemaster	1 - 25 ± 1 L/min air
Air flowrate	Dwyer RMA Ratemaster	5 - 50 ± 2 L/min air
Hydrocarbon concentration	SRI gas chromatograph	0.1 nanogram (0.001 mg/L) to 10 nanogram (0.1 mg/L)
Chromatograph data aquisition	486 PC running PEAKSIMPLE (Version 1.2) software in WINDOWS 3.1 environment	
Air flow pulsing	Gralab 900 electronic timer + Solenoid valve	

to a carbon bed before discharge to the atmosphere. A slip-stream of off-gas is drawn through a 1-mL sample loop and gas sampling valve connected to a gas chromatograph (SRI Instruments, Torrance, CA Model 9300B). A software-driven data aquisition system (PeakSimple for Windows - SRI Instruments, Torrance, CA) is used to automate gas sample analysis and data storage.

The gas chromatograph analysis uses a 15-m long capillary column composed of a 5-micron thick film of 100% non-polar methylsilicone stationary phase. After separation, detection is achieved with a flame ionization detector (FID). The FID consists of a stainless steel jet constructed so that carrier gas exiting the column flows through the jet, mixes with hydrocarbon gas, and burns at the tip of the jet. Hydrocarbons and other molecules ionizing in the flame (i.e. lose an electron) are attracted to a metal collector electrode located just at the side of the flame. The resulting electric current is amplified by a special electrometer amplifier which converts very small currents (pico-amps) to millivolt level signals which are sent to the data system (SRI Instruments, GC product catalog 1995).

min). For hexane, the initial oven temperature of 60°C is held for one minute, after which it is increased at 10°C/min until the final temperature of 70°C is reached (after 1 min). In both cases, the oven must cool down to the initial temperature before another sample can be analyzed. For these conditions, sample intervals of four minutes can be achieved.

The gas chromatograph is calibrated with three samples of known concentrations. For octane they are 0.703 mg/L-air (1 µl-liquid/L), 3.52 mg/L-air (5 µl-liquid/L) and 7.03 mg/L-air (10 µl-liquid/L); for hexane they are 0.66 mg/L-air (1 µl-liquid/L), 3.30 mg/L-air (5 µl-liquid/L) and 6.60 mg/L-air (10 µl-liquid/L). In addition to these concentrations, three other concentrations - 66 mg/L-air (100 µl-liquid/L), 198 mg/L-air (300 µl-liquid/L) and 330 mg/L-air (500 µl-liquid/L) are used for hexane. The calibration is conducted by preparing each standard in a 10-L tedlar bag. This bag is then connected to the GC sample line that is normally connected to the physical model effluent vapor port. Thus, the calibration analyses are conducted in the same manner as the actual vapor sampling of the physical model vapor effluent.

Area counts obtained by integrating the eluting peaks are plotted and analyzed to determine response factors (area counts per unit concentration) for each compound as a function of concentration and detector gain setting. These response factors are then used to calculate concentrations of hydrocarbons in the outlet air from the physical model. For each detector gain setting ("high" or "low") the GC response appears to be linear as long as the detector does not become saturated (output does not exceed 5 V). To check the performance of the gas chromatograph over time, standard runs were made before each experiment. Figure 3.3 through 3.6 present the results of these standard runs, which show very little change in GC response with time.

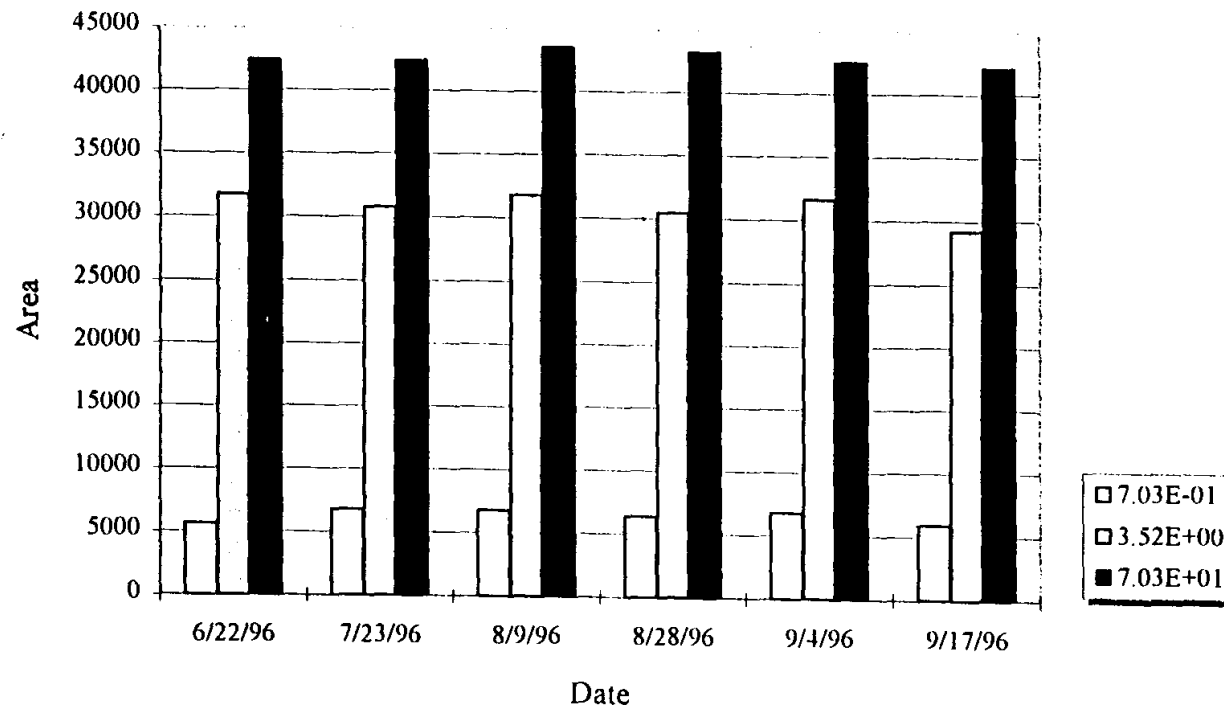

Figure 3.3: Result of standard run for octane on different dates. The sensitivity of the gas chromatograph was set at "high". Octane concentration for standard run were 7.03E-01, 3.52E+00 & 7.03E+01 mg/L-air.

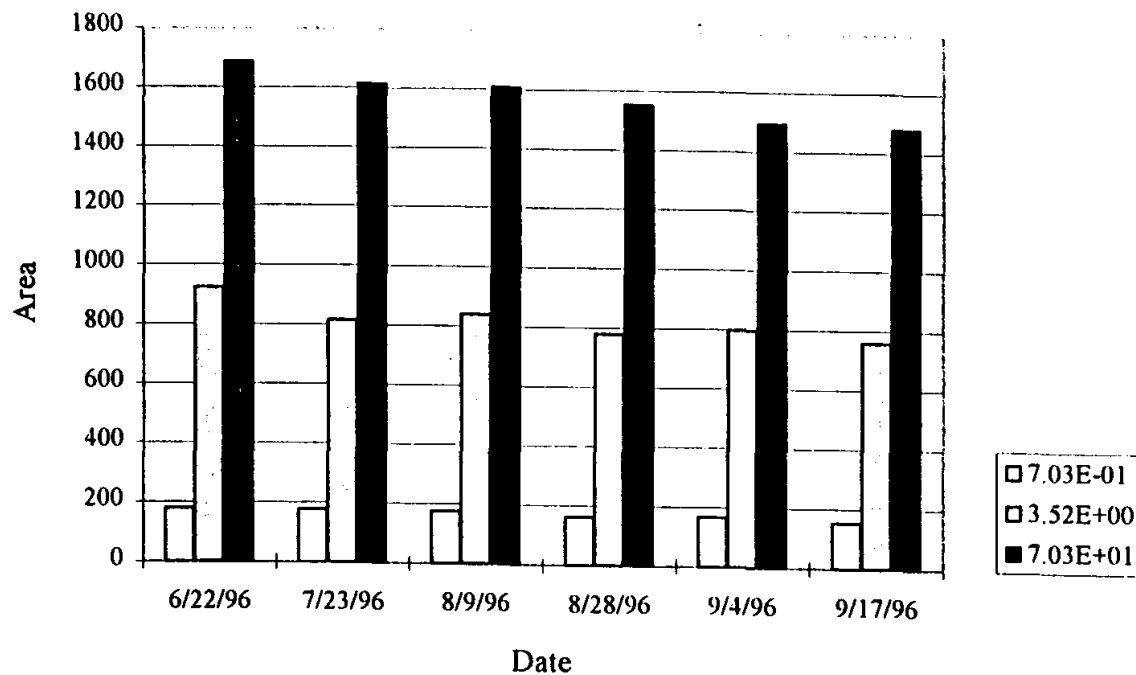

Figure 3.4: Result of standard run for octane on different dates. The sensitivity of the gas chromatograph was set at "low". Octane concentration for standard run were 7.03E-01, 3.52E+00 & 7.03E+01 mg/L-air.

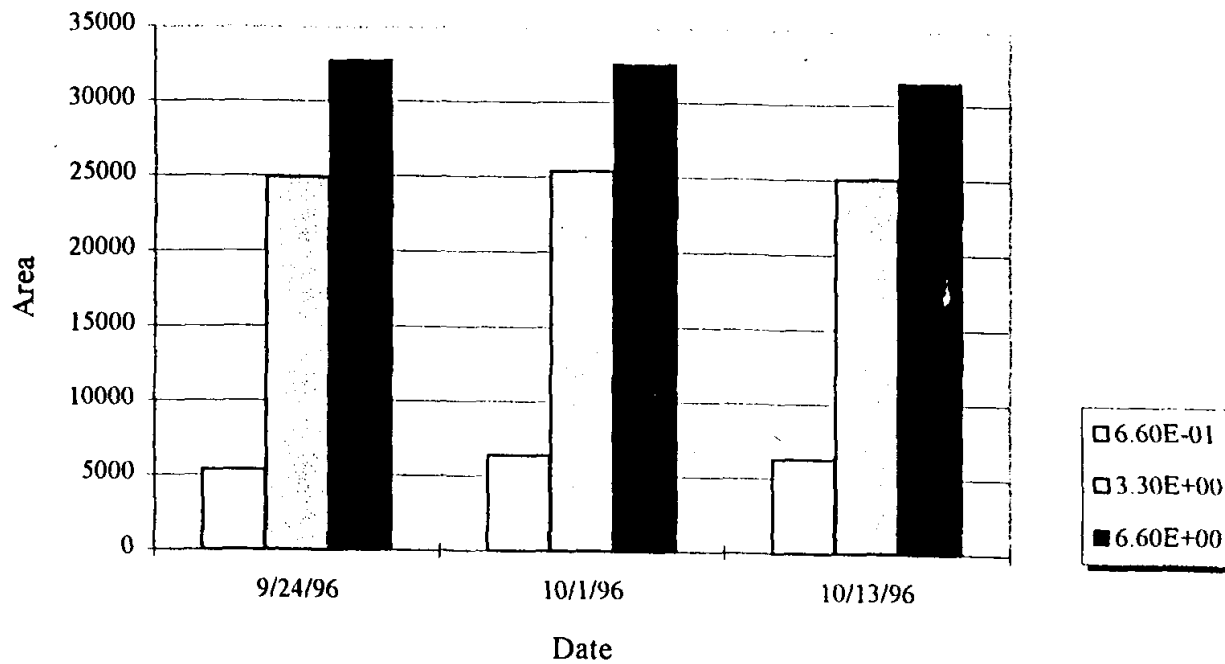

Figure 3.5: Result of standard run for hexane on different dates. The sensitivity of the gas chromatograph was set at "high". Hexane concentration for standard run were 0.66, 3.30- & 6.60 mg/L-air.

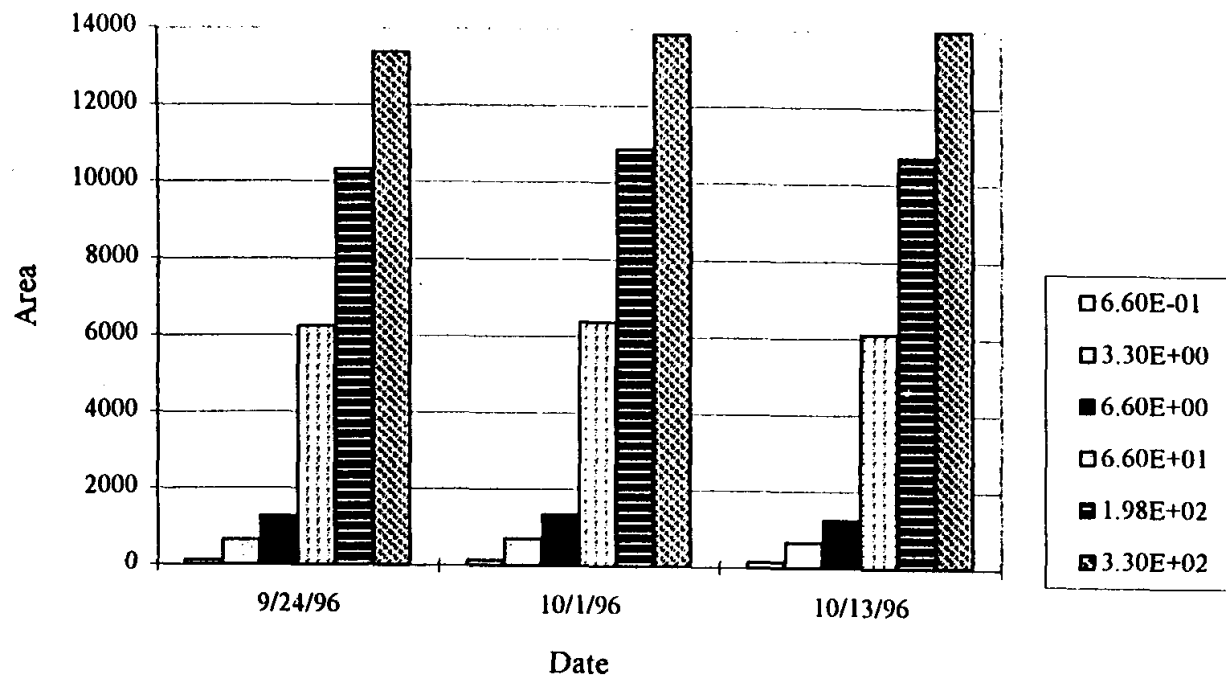

Figure 3.6: Result of standard run for hexane on different dates. The sensitivity of the gas chromatograph was set at "low". Hexane concentration for standard run were 6.6E-01, 3.30, 6.60, 6.6E+01, 1.98E+02 & 3.30E+02 mg/L-air.

All flow meters are calibrated using a standard volume displacement method. A 1-L graduated cylinder is filled with water and then inverted in a water-filled bucket. The air flow line from a flow meter is inserted inside the inverted cylinder and the volume of water displaced by air in a given time period is recorded along with the flow meter reading. This volume divided by the time period then yields the flow rate, which is then compared with the flow meter reading.

Properties of the medium used

1-mm spherical glass beads (Jaygo, Inc.) were used for all the mass removal experiments described in this thesis. They provide a uniform homogeneous medium for the experiments. Table 3.3 lists the chemical and physical properties of the glass beads.

Table 3.3. Summary of glass beads properties (Rutherford 1995).

Chemical Properties	
Silica (SiO ₂)	67%
Aluminium Oxide (Al ₂ O ₃)	1%
Potassium Oxide (K ₂ O)	7%
Barium Oxide (BaO)	6%
Boric Oxide (B ₂ O ₂)	2%
Lime (CaO)	5%
Soda (Na ₂ O)	10%
Magnesium Oxide (MgO)	1%
Physical properties	
Specific Gravity	2.55
Apparent Weight	1.4 - 1.6 kg/L

Properties of the chemicals used

Two hydrocarbons were used in these studies - n-octane ($n\text{-C}_8\text{H}_{18}$) and n-hexane ($n\text{-C}_6\text{H}_{14}$).

Both these compounds are less dense than water and fairly insoluble in water. The pure component vapor pressure of these compounds differ approximately by a factor of 10; their solubilities vary by a factor of

18. Both of these compounds are extremely flammable and are harmful to the respiratory systems if swallowed or inhaled. Hexane can also produce damage to kidneys and nerves. Octane can cause irritation to the eyes and skin.

Table 3.4. Properties of chemicals used in the experiments.

Compound	Notation	ρ^* [g/mL]	M_w^* [g/mole]	H_1	b^P [°C]	S_1^* [mg/L]	P^V [atm]
Octane	$\text{CH}_3(\text{CH}_2)_6\text{CH}_3$	0.7028	114.23	93	126	0.7	0.014
Hexane	$\text{CH}_3(\text{CH}_2)_4\text{CH}_3$	0.66034	86.18	43	69	13	0.16

* Verschueren K. 1977.

ρ = density

M_w = molecular weight of compounds.

b^P = boiling point at 1 atm absolute pressure. P^V = pure component vapor pressure at 20°C.

S_1 = water solubility of compounds at 20°C $H_1 = C_1^V / S$

H_1 = dimensionless Hery's Law Constant C_1^V = contaminant vapor concentration [mg/L]

Experimental Procedure

As is often the case with experimental work, the experimental procedures were refined as more experiments were conducted; thus, the following chapters refer to “preliminary”, “intermediate”, and “final” volatilization studies. The procedure for each is described below:

Preliminary experiments - were conducted primarily to assess the performance of the physical model and overall mass balance accuracy. In these experiments all the water was drained out from the physical model and 10 mL of octane was injected through a tube into the upper 0.3-m of the glass beads. Octane was injected at the center of the physical model, directly above the air injection point of the physical model. Air injection was then started in the case of dry media experiments. For wet media experiments, the tank was refilled with water to a height of 97 cm (38 in) before starting the air injection. The air flow rate was maintained at 11 L/min until effluent octane vapor concentration decreased to ~ 0.1 mg/L.

Intermediate Volatilization Experiments - based on the results of the preliminary volatilization experiments the experimental protocol included the following steps:

- a) the gas chromatograph is calibrated using known concentrations sampled through the sample loop,
- b) the water table is raised to a level 5-cm (2 in) below the injection tube outlet, with the injection tube outlet being 102 cm (40 in) from the bottom of the physical model,
- c) 50 mL of hydrocarbon liquid is injected into the injection tube with a syringe,
- d) the fluid is allowed to spread across the water table for 10 min,

- e) the water table is lowered to a height of about 0.3 m (1 ft) from the bottom of the tank by draining water from the bottom ports,
- f) for saturated media experiments, the water table is raised back to the original level used in (b); otherwise the water level is maintained at 0.3 m (1 ft) from the bottom of the tank,
- g) automated GC vapor sampling and analysis is initiated,
- h) air injection is initiated at the predetermined flow rate and flow conditions and flow and sampling are continued until the end of the experiment,

Final Volatilization Experiments - to obtain better mass balance closure, the steps described above were augmented by the addition of a final step (i):

- i) at some predetermined time, lower the water table to expose all hydrocarbon-contaminated media and continue air injection and sampling and GC analysis until vapor concentrations decline to about 0.01 mg/L.

CHAPTER 4

RESULTS

This chapter presents the results from the source zone volatilization studies conducted in the two-dimensional aquifer physical model described in Chapter 3. Chapter 3 also contains a discussion of the experimental methods. In Chapter 5 the data is analyzed and interpreted.

Recall that the goal of these experiments is to identify factors that affect the volatilization of residual non-aqueous phase hydrocarbon "source zones". Those factors investigated include flow rate changes, process flow conditions (steady vs. pulsed air injection), chemical type, and source location.

Preliminary volatilization experiments

As discussed in Chapter 3 the primary goal of these preliminary experiments was the assessment of the operation of the system and assessment of overall mass balance closure. Two "dry" media (hydrocarbon placed above the water table) experiments and one "wet" media experiment (hydrocarbon placed below the water table) were conducted in this phase. Here the term "dry" is somewhat of a misnomer as the media is unsaturated but does contain residual water trapped by capillary forces. Table 4.1 defines the attributes of these experiments. Effluent octane vapor concentrations are plotted in Figure 4.1 through Figure 4.3.

Table 4.1. Specific attributes of the preliminary octane volatilization experiments.

Experiment #	Experimental Phase	Media Condition	Air Flow rate Q_{air} [L/min]	Pulsed (Yes/No)	Injected mass M^o [mg]
1	Preliminary	Dry	11	N	7030
2	Preliminary	Dry	11	N	7030
3	Preliminary	Wet	11	N	7030

Intermediate volatilization experiments

In this phase three dry media experiments and three wet media experiments were conducted. Experimental procedures can be found in Chapter 3. Table 4.2 defines the experimental conditions for these experiments. Figures 4.4 through 4.6 present the measured effluent octane concentration for dry media experiments. Figures 4.7 through 4.9 present results from wet media experiments.

Table 4.2. Specific attributes of the intermediate octane volatilization experiments.

Experiment #	Experimental Phase	Media Condition	Air Flow rate Q_{air} [L/min]	Pulsed (Yes/No)	Injected mass M^o [mg]
4	Intermediate	Dry	1.25	N	35140
5	Intermediate	Wet	1.25	N	35140
6	Intermediate	Dry	10	N	35140
7	Intermediate	Wet	10	N	35140
8	Intermediate	Dry	10	Y	35140
9	Intermediate	Wet	10	Y	35140

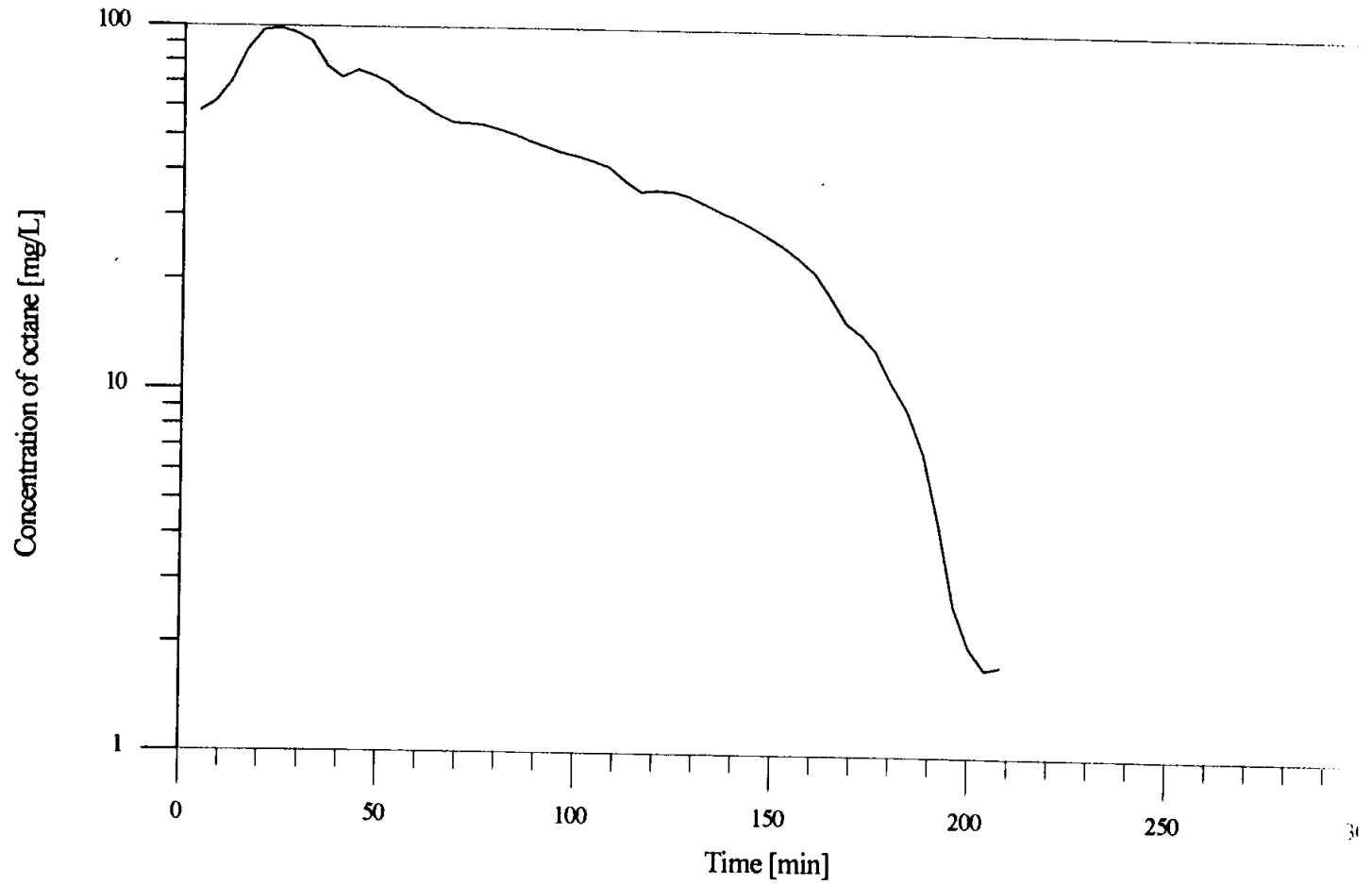

Figure 4.1: Octane concentration in the outlet air of the physical model vs. time for $Q_{air} = 11$ L/min steady injection and $M = 7.03$ g., preliminary dry medium experiment.

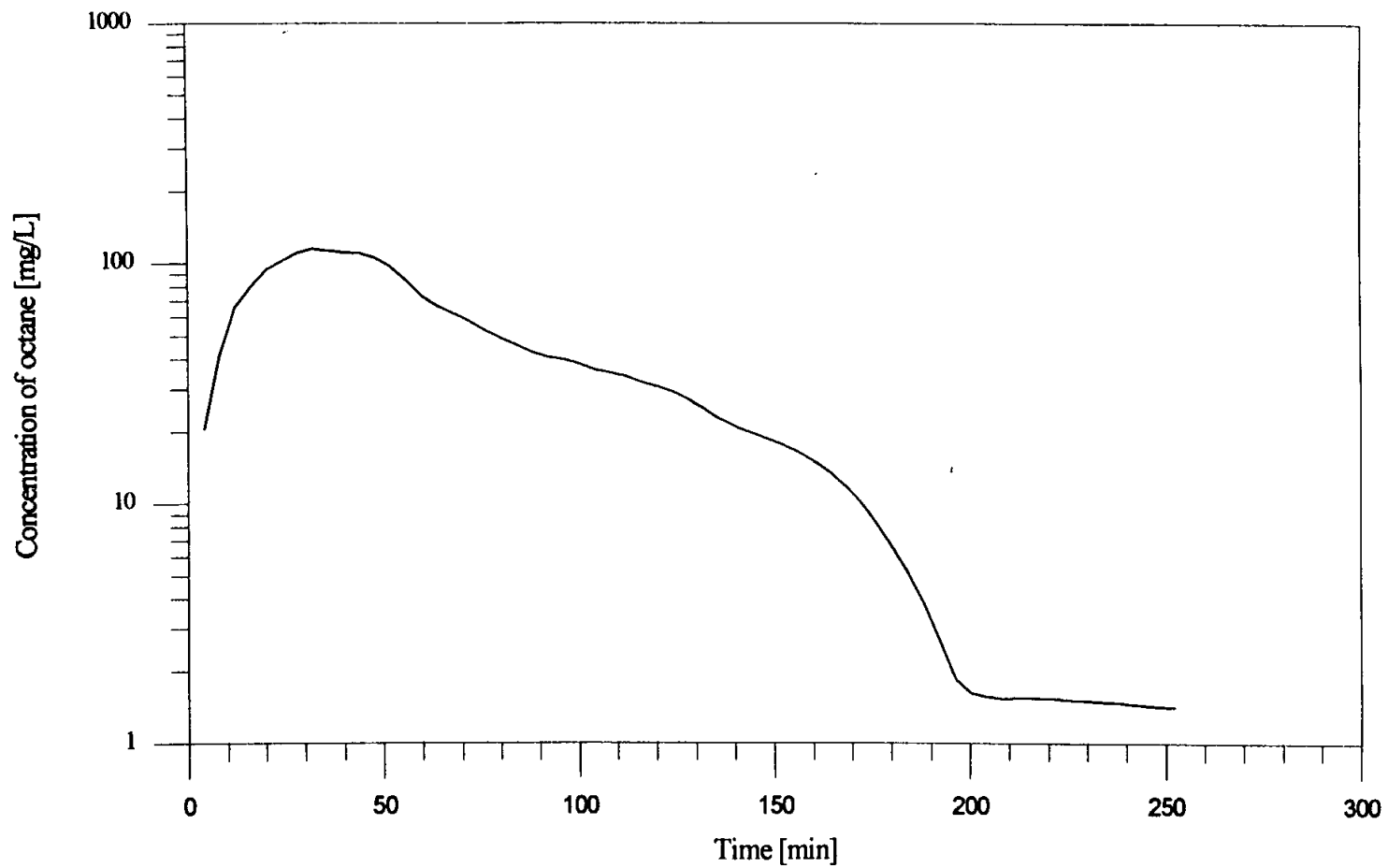

Figure 4.2: Octane concentration in the outlet air of the physical model vs. time for $Q_{air} = 11$ L/min steady injection and $M = 7.03$ g., preliminary dry medium experiment.

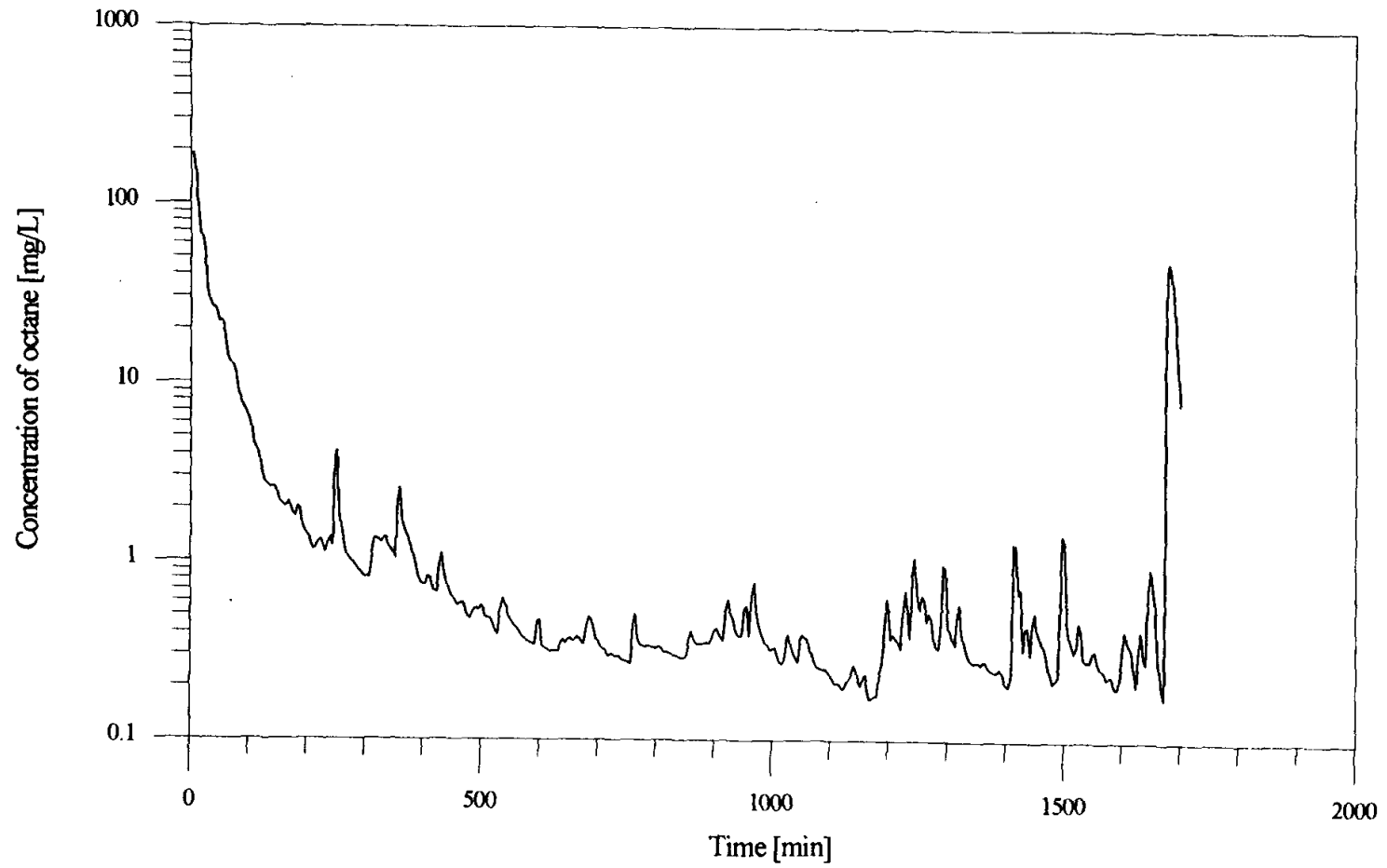

Figure 4.3: Octane concentration in the outlet air of the physical model vs. time for $Q_{air} = 11$ L/min steady injection and $M = 7.03$ g., preliminary wet medium experiment.

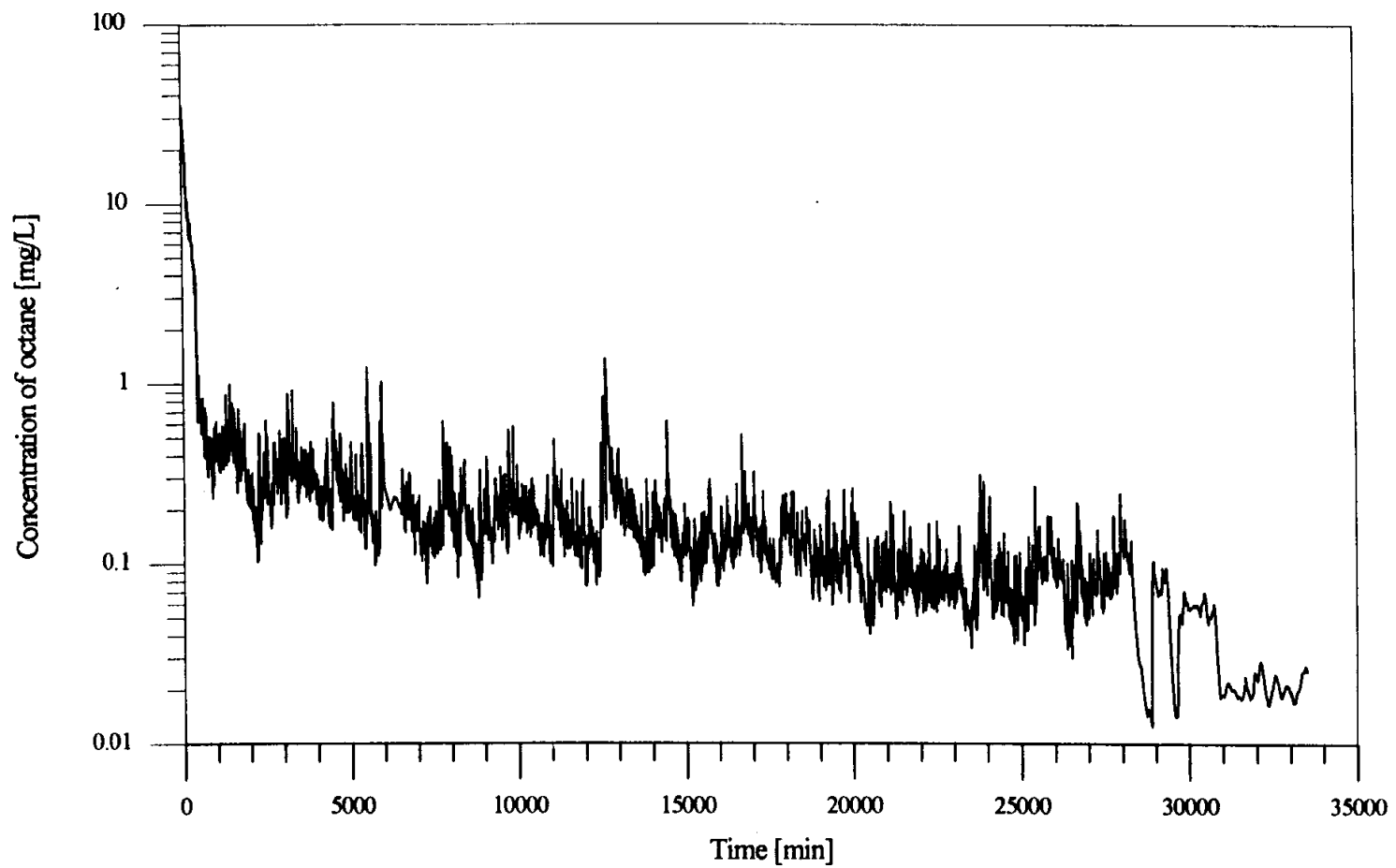

Figure 4.5: Octane concentration in the outlet air of the physical model vs. time for $Q_{air} = 1.25$ L/min steady injection and $M = 35.14$ g., intermediate wet medium experiment.

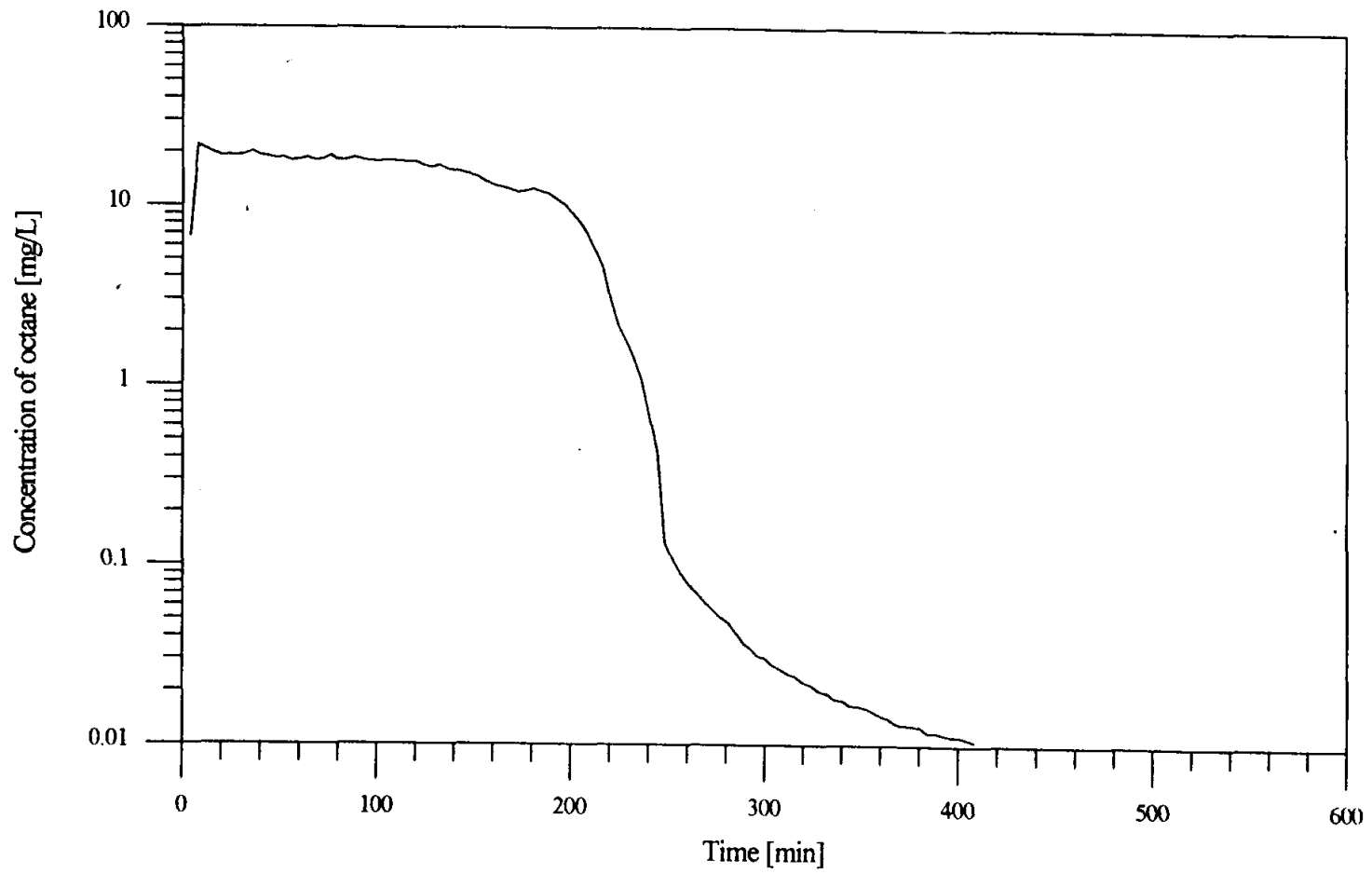

Figure 4.6: Octane concentration in the outlet air of the physical model vs. time for $Q_{air} = 10$ L/min steady injection and $M^p = 35.14$ g., intermediate dry medium experiment.

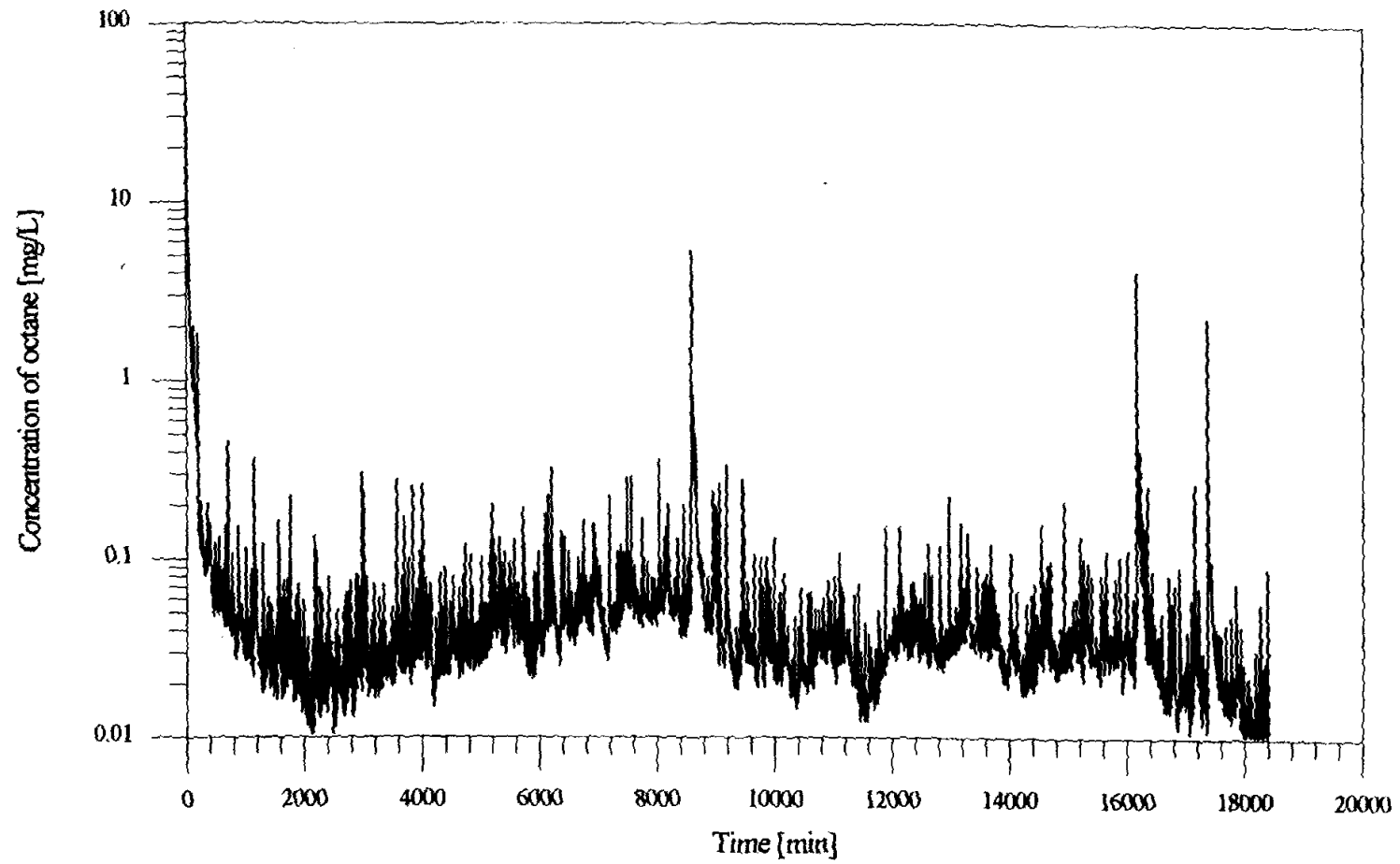

Figure 4.7: Octane concentration in the outlet air of the physical model vs. time for $Q_{air} = 10$ L/min steady injection and $M^f = 35.14$ g., intermediate wet medium experiment.

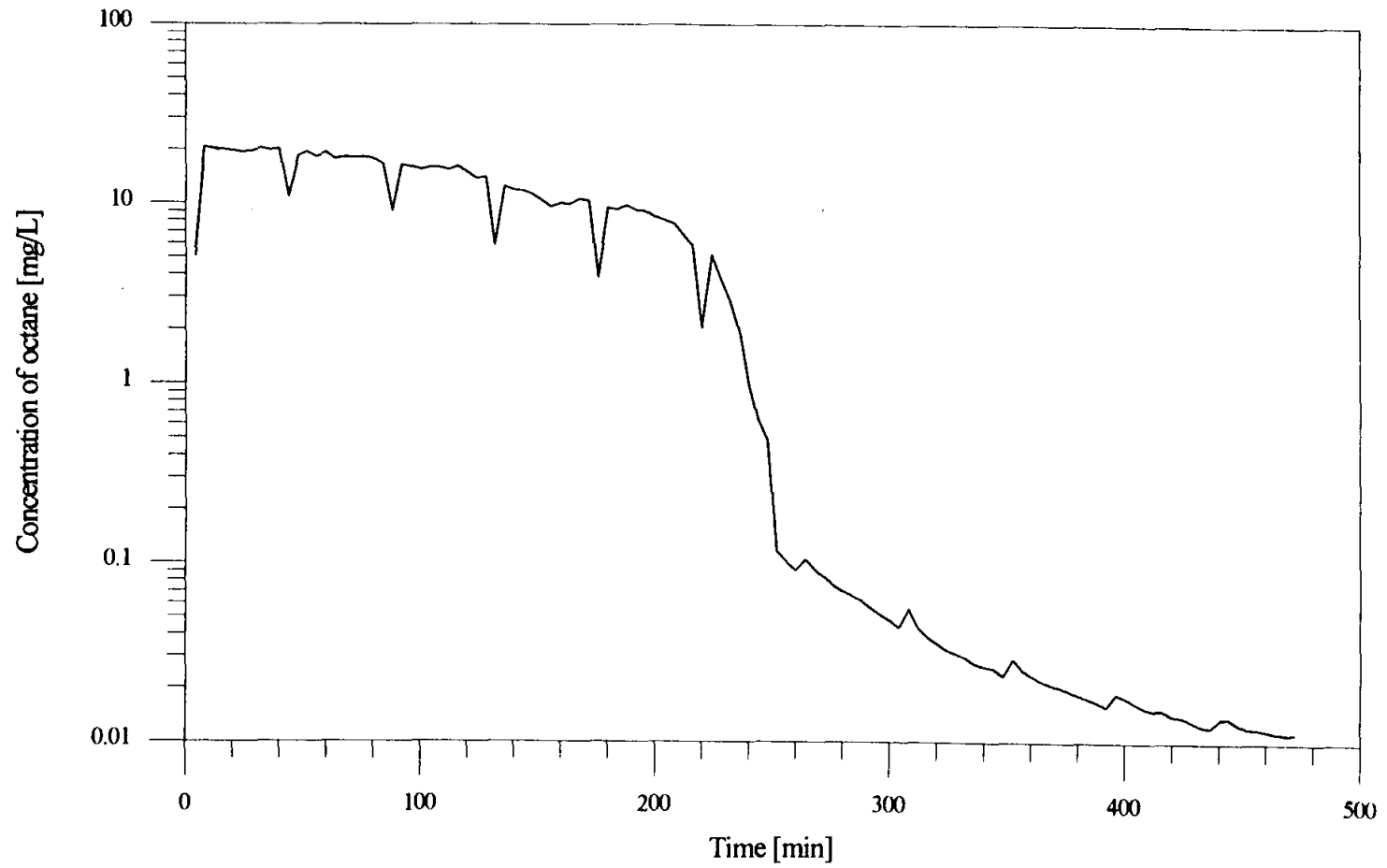

Figure 4.8: Octane concentration in the outlet air of the physical model vs. time for $Q_{air} = 10$ L/min pulsed injection and $M^{\#} = 35.14$ g., intermediate dry medium experiment.

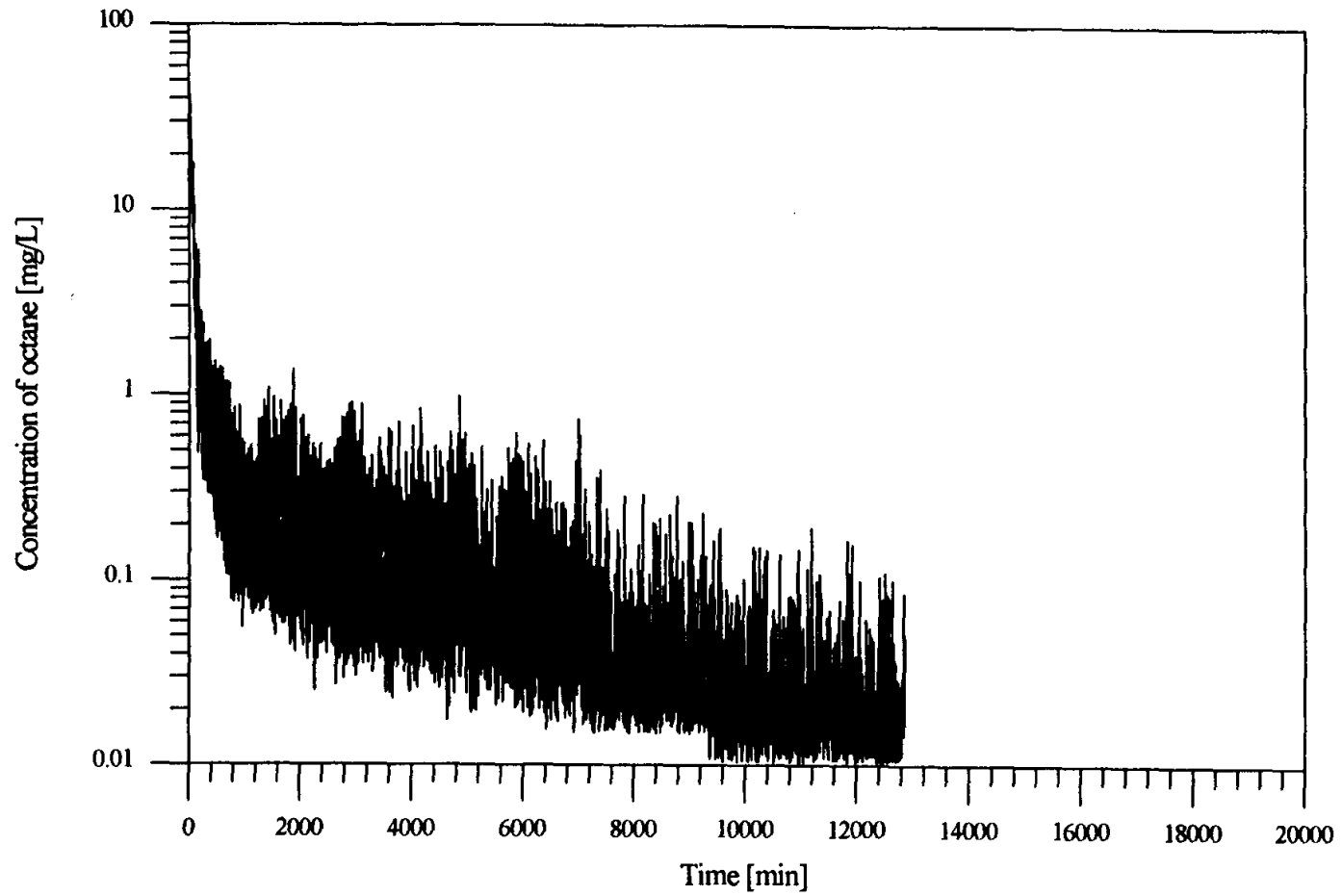

Figure 4.9: Octane concentration in the outlet air of the physical model vs. time for $Q_{air} = 10$ L/min pulsed injection and $M^p = 35.14$ g., intermediate wet medium experiment.

Final Volatilization Experiments

Table 4.3 defines attributes of the experiments conducted in this phase. Three experiments were conducted for each flow rate, which included 1.25 L/min steady air injection, 10 L/min steady air injection, and 10 L/min pulsed air injection (200 s on, 20 s off). Figure 4.10 through 4.11 present measured effluent octane concentrations for the 1.25 L/min air flow rate. Figure 4.12 through 4.14 and Figure 4.15 through 4.17 present results for flows 10 L/min steady air injection and 10 L/min pulsed air injection, respectively.

Table 4.4 summarizes the attributes for the hexane volatilization experiments. Results for the dry media hexane experiment are presented in Figure 4.18. Figures 4.19 and 4.20 present the effluent hexane concentrations for wet media experiments.

Table 4.3. Defining attributes of final volatilization experiments for octane removal.

Experiment #	Experimental Phase	Media Condition	Air Flow rate Q_{air} [L - air/min]	Pulsed [yes/No]	Time draining started [min]	Injected mass [mg]
10	Final	Wet	1.25	N	3347	35140
11	Final	Wet	1.25	N	5656	35140
12	Final	Wet	10	N	7105	35140
13	Final	Wet	10	N	3376	35140
14	Final	Wet	10	N	4664	35140
15	Final	Wet	10	Y	6983	35140
16	Final	Wet	10	Y	4016	35140
17	Final	Wet	10	Y	4184	35140

Table 4.4. Defining attributes of volatilization experiments for hexane removal.

Experiment #	Phase	Media	Air Flow rate Q^{air} [L - air/min]	Pulsed [yes/No]	Time draining started [min]	Injected mass M° [mg]
18	Intermediate	Dry	10	N	-	33000
19	Final	Wet	10	N	3556	33000
20	Final	Wet	10	Y	2174	33000

Volatilization studies - sources located away from the air flow field

The goal of this experiment was to evaluate the impact of sparge well location on residual non-aqueous phase hydrocarbon removal.

In this experiment (Expt # 21) 50 mL of octane was injected 0.6 m (2 ft) laterally from the air injection port. The same protocol as that described for the intermediate volatilization experiments in Chapter 3 was employed. A steady air injection flow rate of 10 L/min was used and the effluent off-gas vapors were monitored. Next a water recirculation rate of 30 cm³/min was started; water was removed from one end of the tank and reintroduced at the other end to create a horizontal flow field. After sometime the water recirculation flow rate was increased to 270 cm³/min. Mass balance calculations at the end 4.5 days did not show any improvement. Eventually, pulsing of the air flow was initiated. Table 4.5 summarizes details of this experiment and Figure 4.22 presents the effluent octane concentrations vs. time for this experiment.

Table 4.5. Defining attributes of wet medium experiment with source located away from the air flow field.

Time [min]	Time [d]	Attributes
0	0	steady 10 L/min air flow
968	0.67	steady 10 L/min air flow + water circulation at 30 cm ³ /min
1360	0.94	steady 10 L/min air flow + water circulation at 270 cm ³ /min
6780	4.7	pulsed 10 L/min air flow + water circulation at 270 cm ³ /min
12524	8.7	pulsed 10 L/min air flow + water circulation at 270 cm ³ /min but direction is reversed
14012	9.7	pulsed 10 L/min air flow + water circulation stopped, draining started

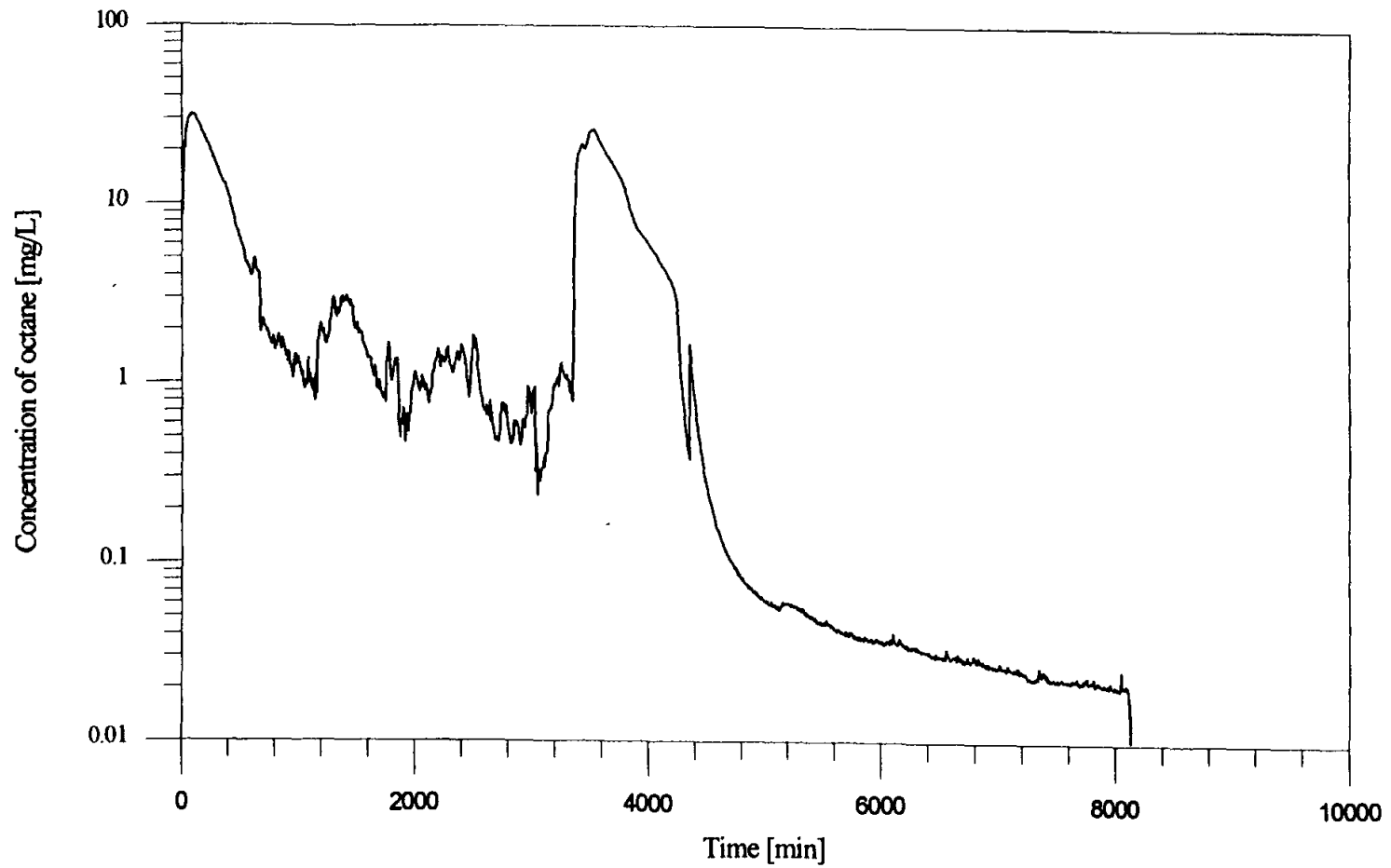

Figure 4.10: Octane concentration in the outlet air of the physical model vs. time for $Q_{air} = 1.25$ L/min steady injection and $M^0 = 35.14$ g., final wet medium experiment. Draining of the physical model occurred at 3347 min.

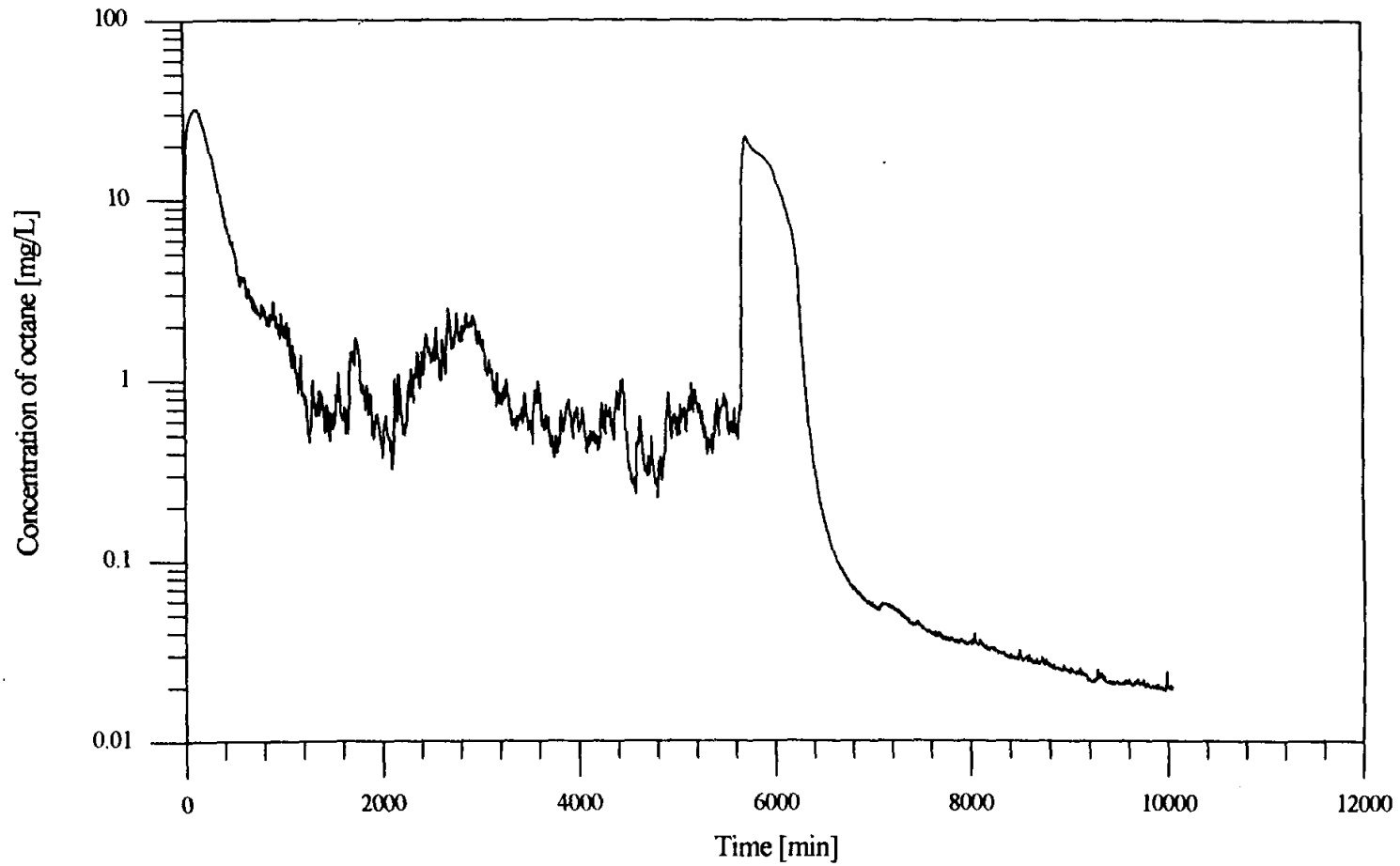

Figure 4.11: Octane concentration in the outlet air of the physical model vs. time for $Q_{air} = 1.25$ L/min steady injection and $M^f = 35.14$ g., final wet medium experiment. Draining of the physical model occurred at 5656 min

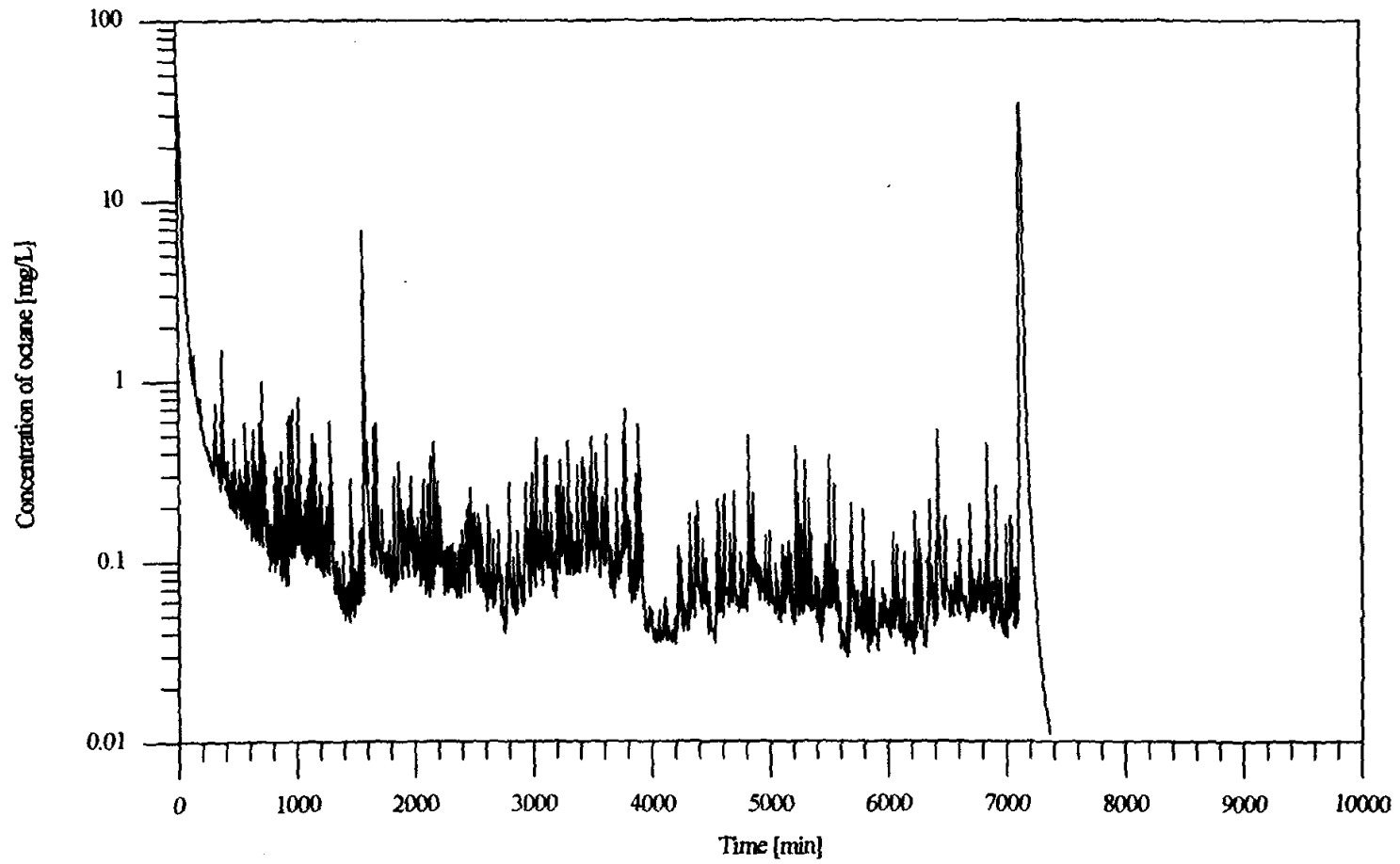

Figure 4.12: Octane concentration in the outlet air of the physical model vs. time for $Q_{air} = 10 \text{ L/min}$ steady injection and $M^0 = 35.14 \text{ g.}$ final wet medium experiment. Draining of the physical model occurred at 7105 min

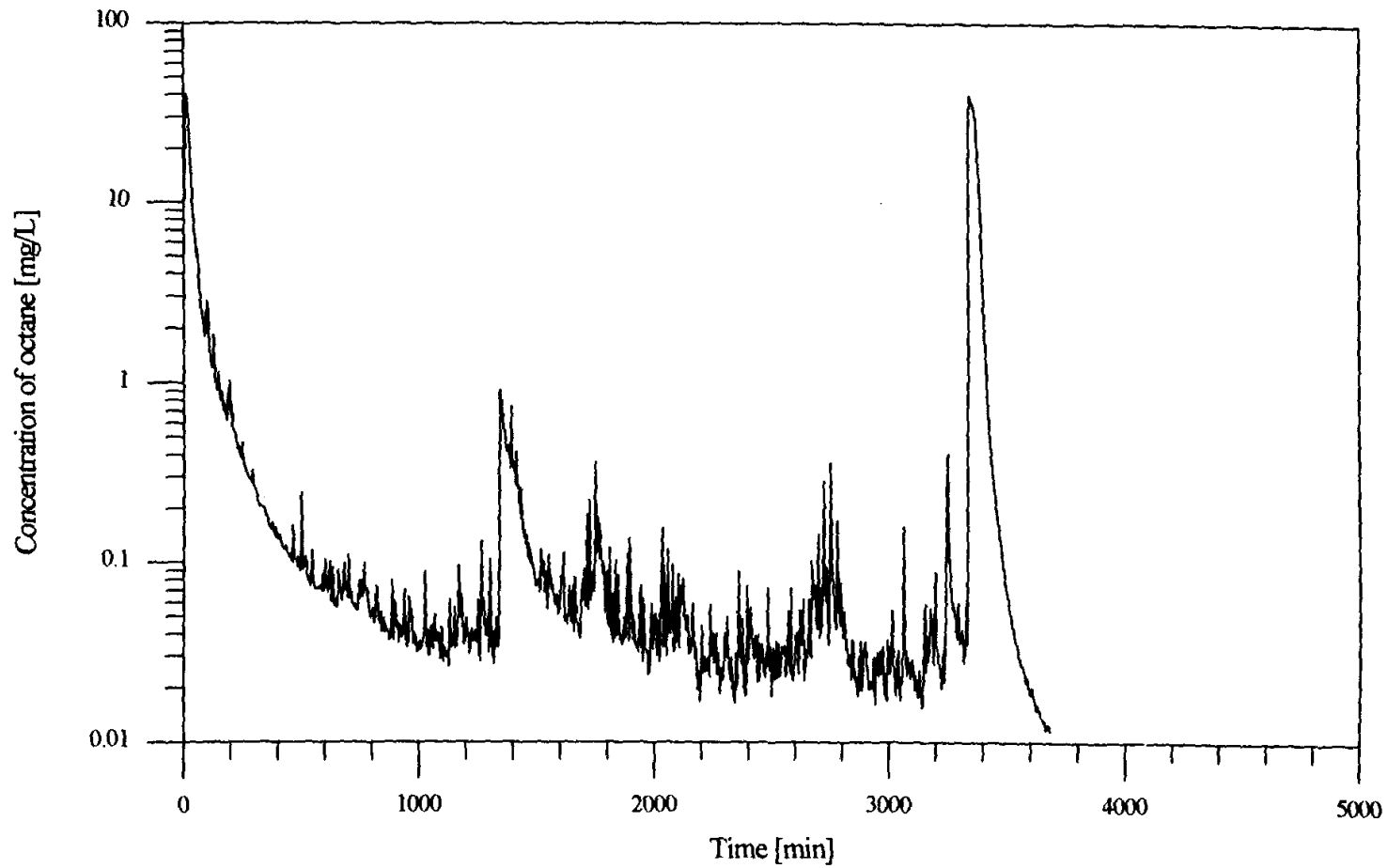

Figure 4.13: Octane concentration in the outlet air of the physical model vs. time for $Q_{air} = 10$ L/min steady injection and $M^f = 35.14$ g., final wet medium experiment. Draining of the physical model occurred at 3335 min

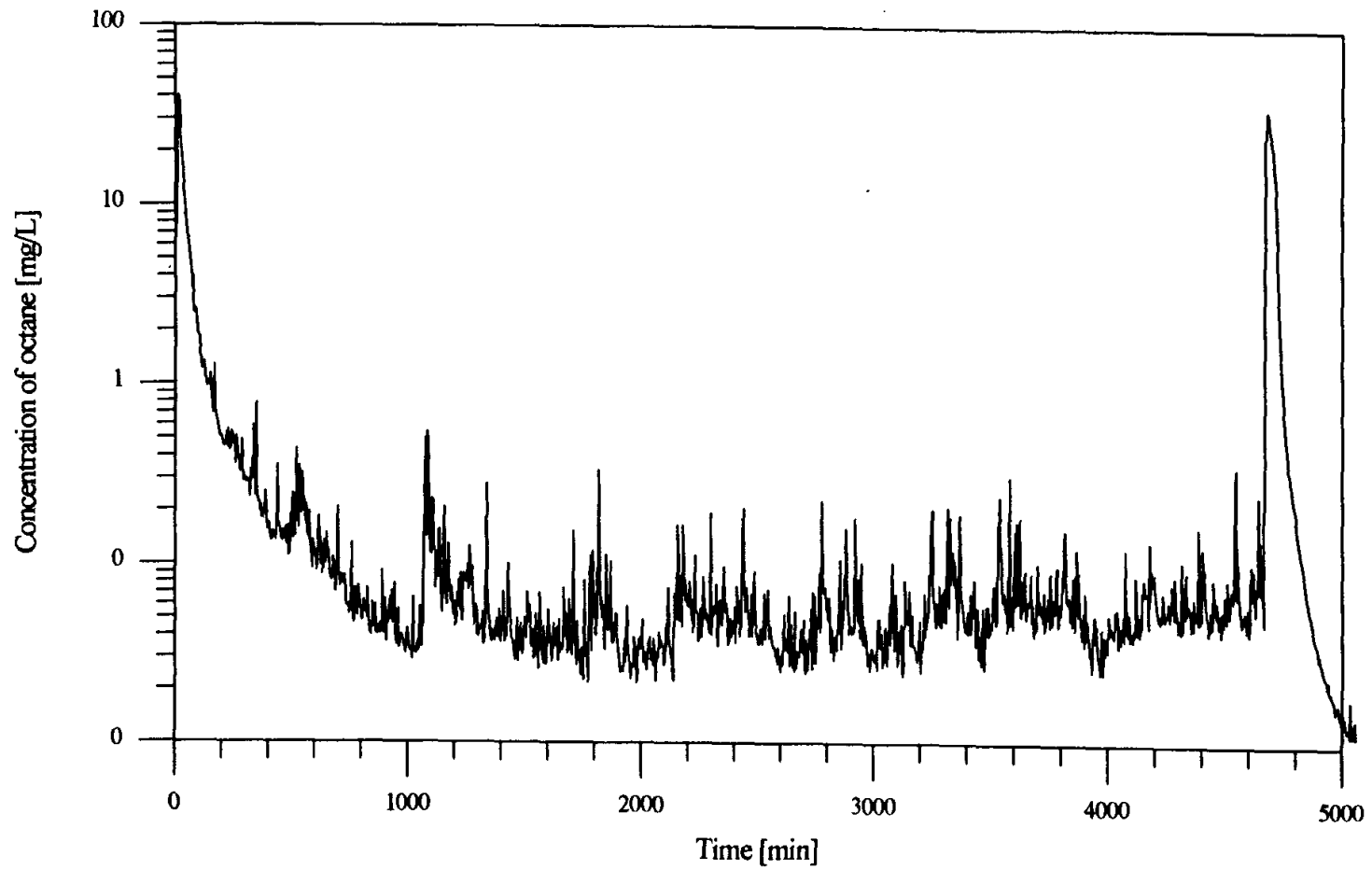

Figure 4.14: Octane concentration in the outlet air of the physical model vs. time for $Q_{air} = 10$ L/min steady injection and $M^f = 35.14$ g., final wet medium experiment. Draining of the physical model occurred at 4664 min

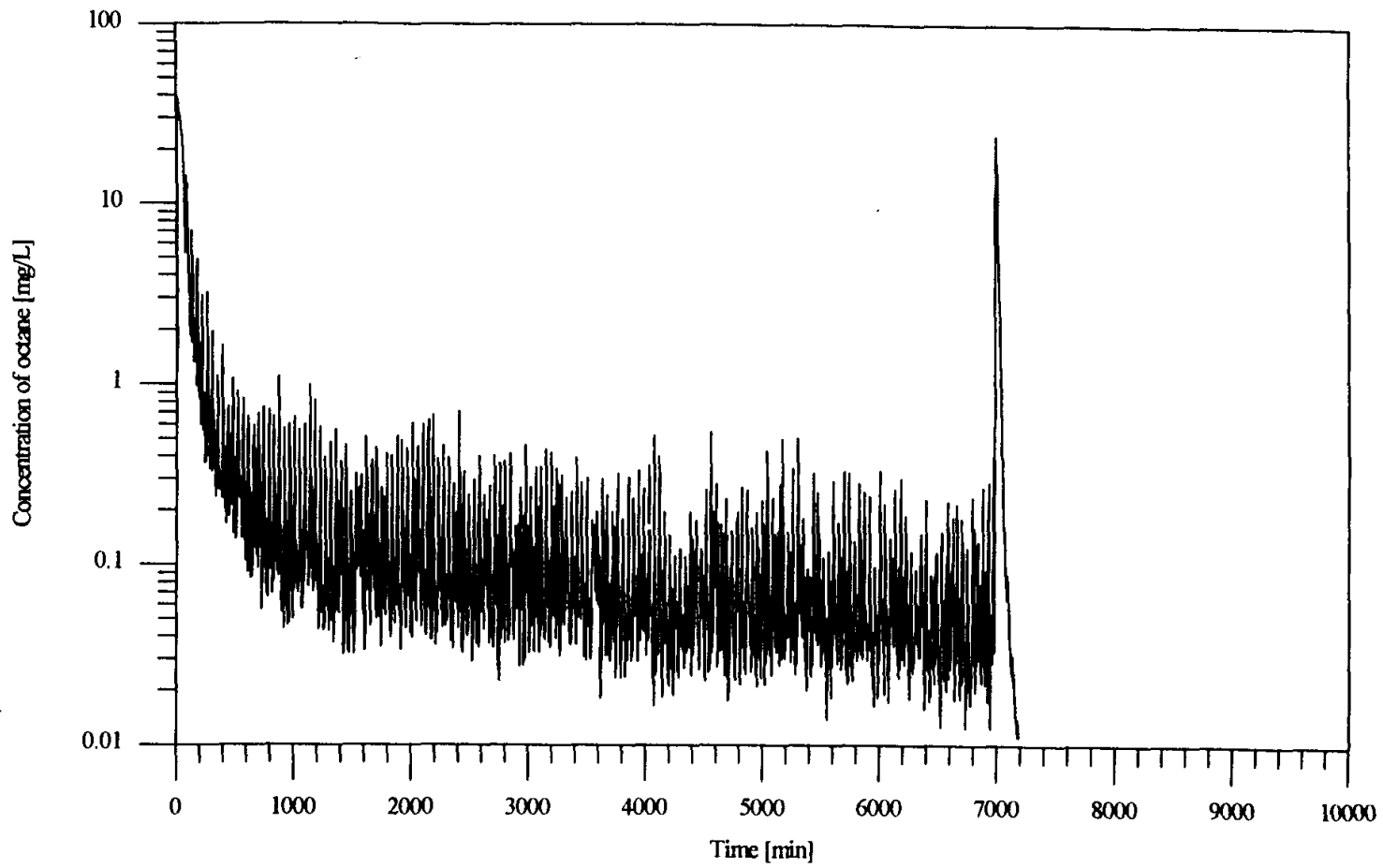

Figure 4.15: Octane concentration in the outlet air of the physical model vs. time for $Q_{air} = 10$ L/min pulsed injection and $M^f = 35.14$ g., final wet medium experiment. Draining of the physical model occurred at 6983 min

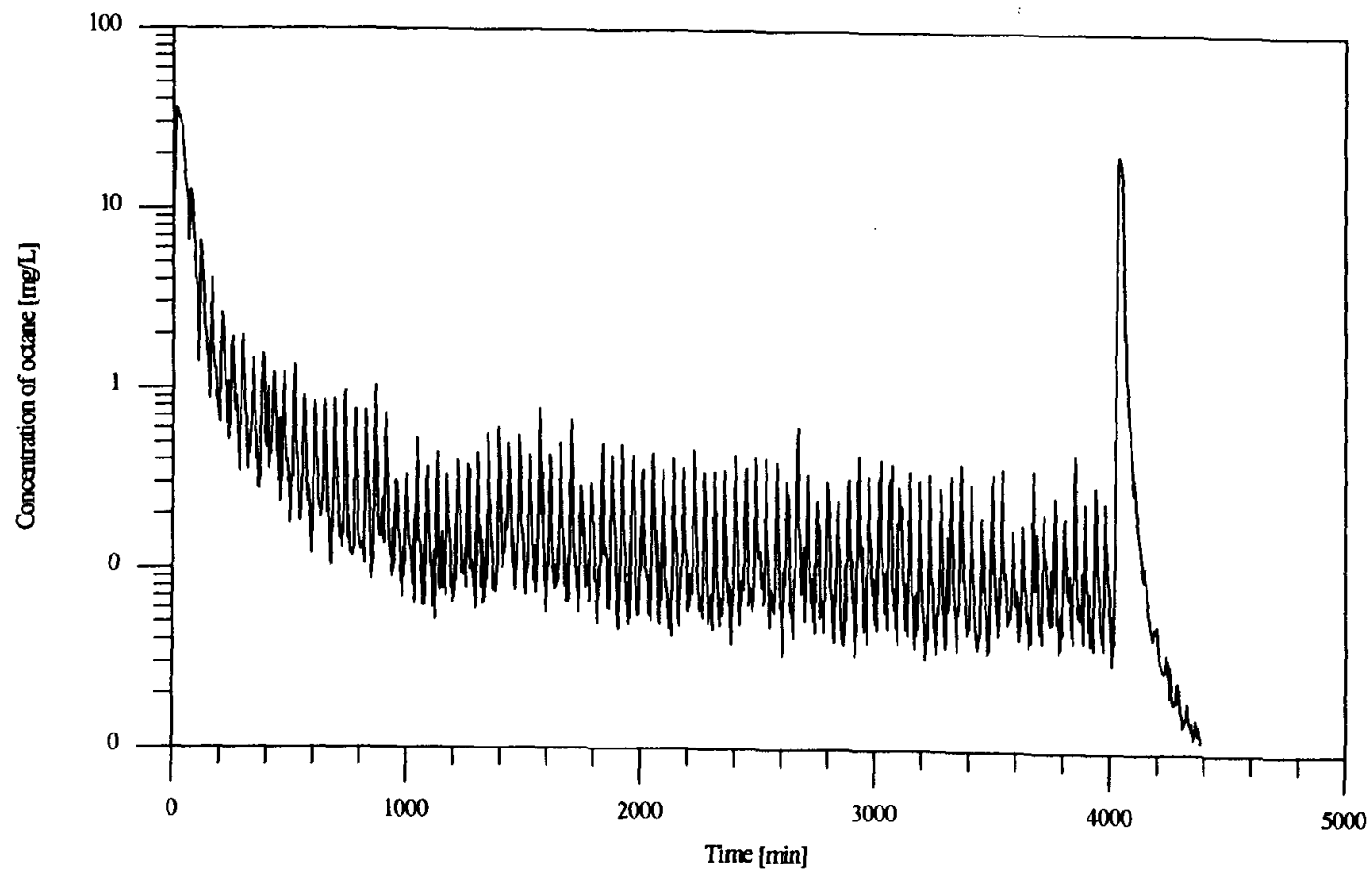

Figure 4.16: Octane concentration in the outlet air of the physical model vs. time for $Q_{air} = 10 \text{ L/min}$ pulsed injection and $M^f = 35.14 \text{ g.}$, final wet medium experiment. Draining of the physical model occurred at 4016 min

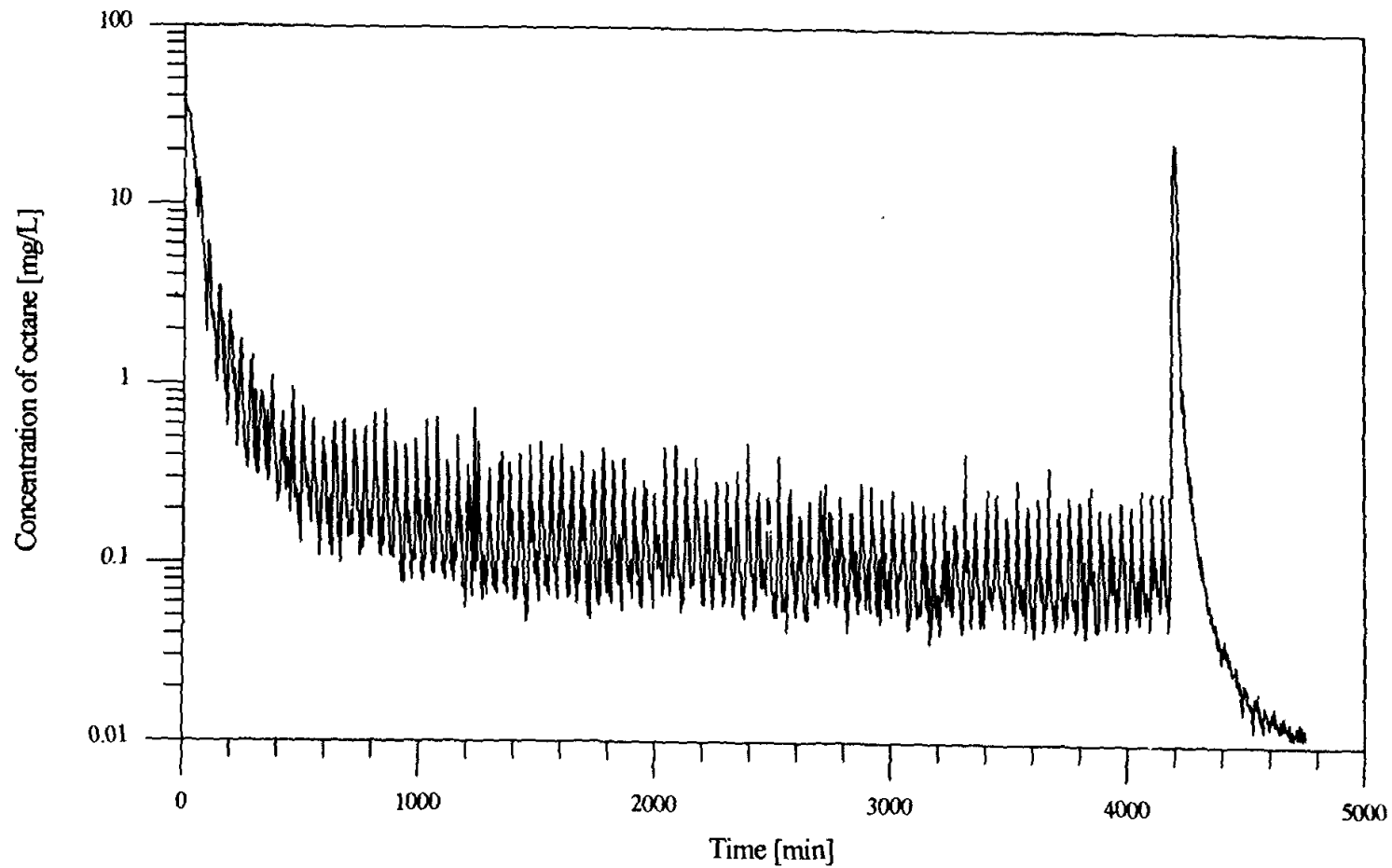

Figure 4.17: Octane concentration in the outlet air of the physical model vs. time for $Q_{air} = 10$ L/min pulsed injection and $M^p = 35.14$ g., final wet medium experiment. Draining of the physical model occurred at 4184 min

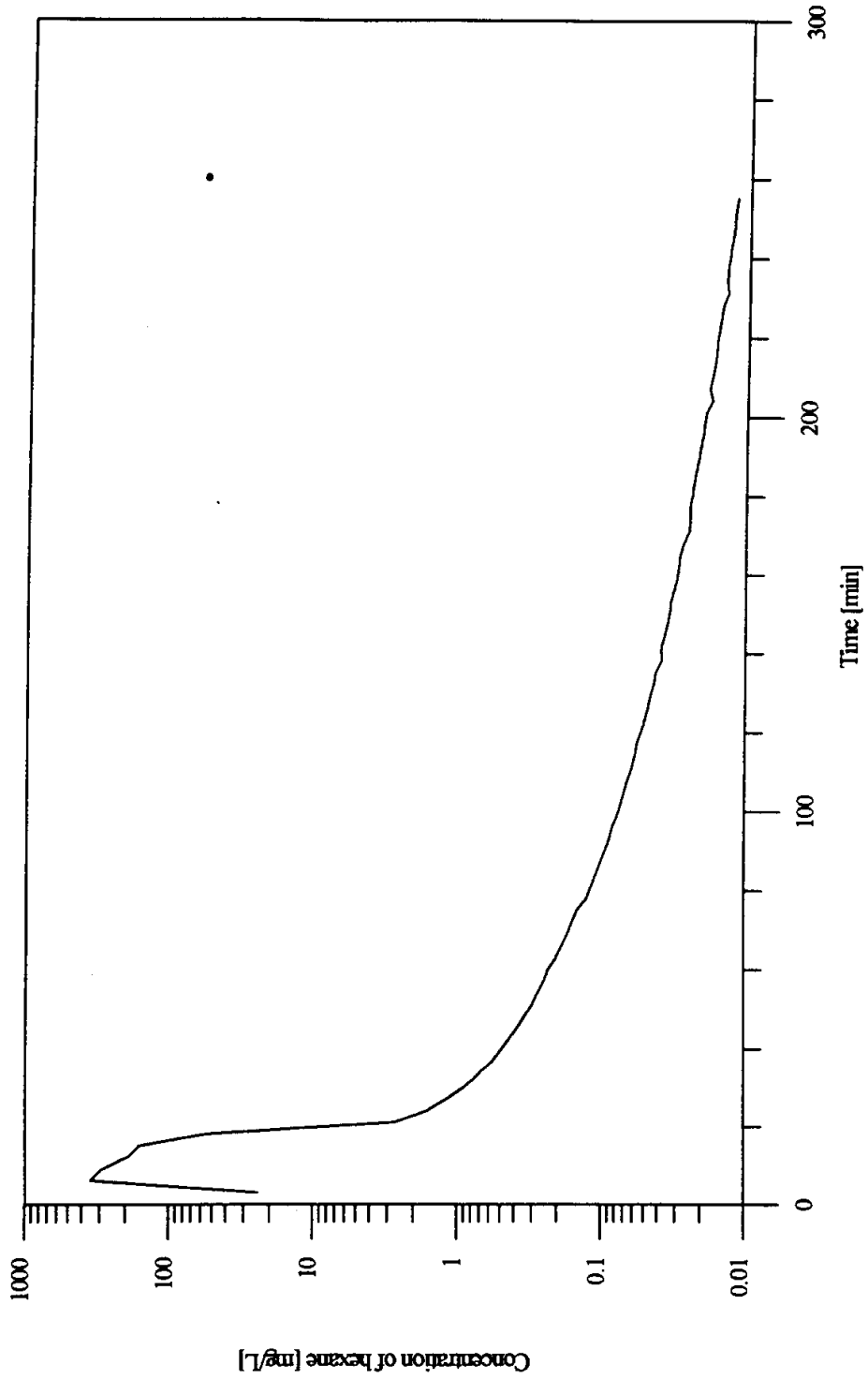

Figure 4.18: Hexane concentration in the outlet air of the physical model vs. time for $Q_{air} = 10 \text{ L/min}$ steady injection and $M_f = 33 \text{ g}$, intermediate dry medium experiment.

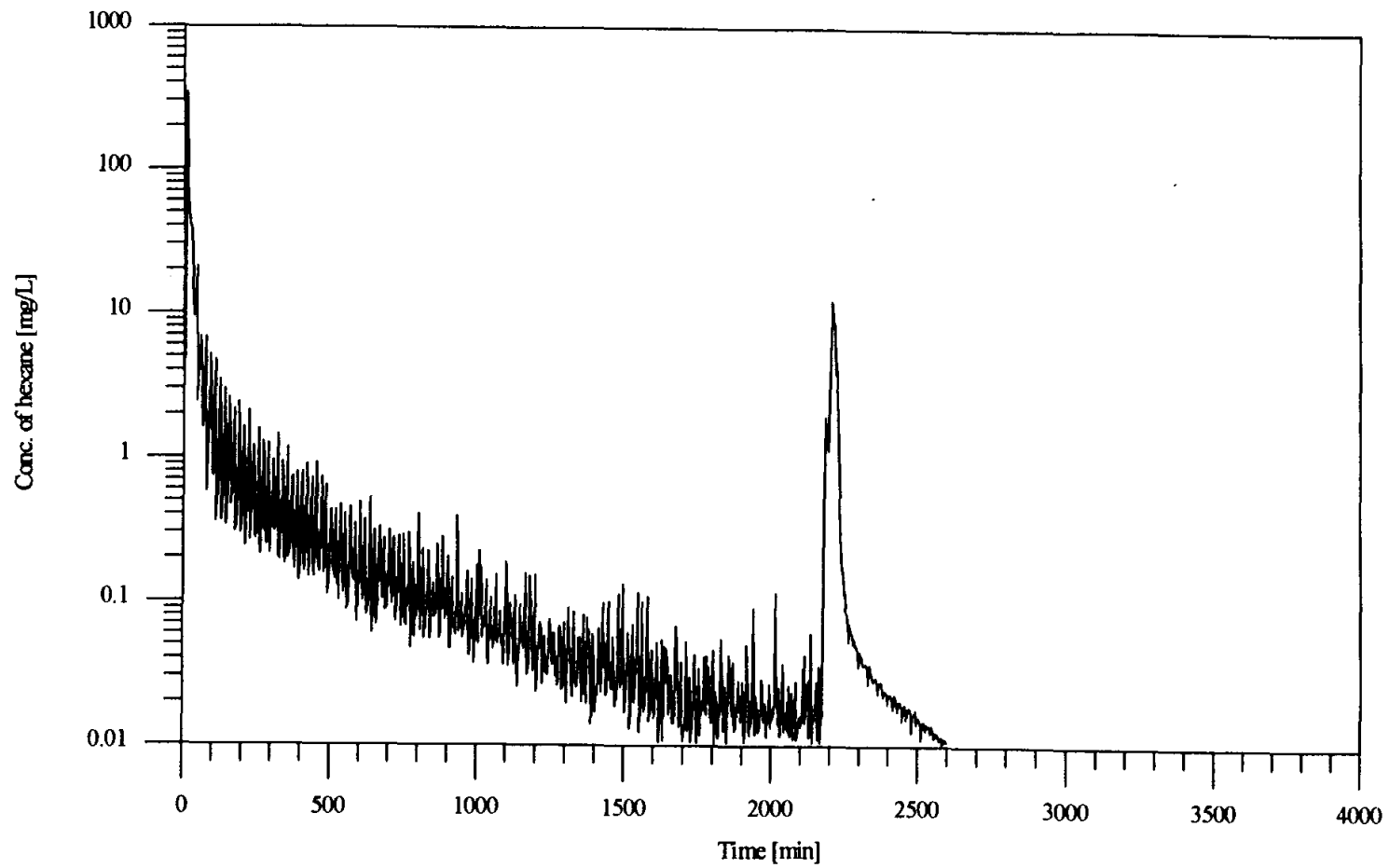

Figure 4.19: Hexane concentration in the outlet air of the physical model vs. time for $Q_{air} = 10$ L/min steady injection and $M = 33$ g., final wet medium experiment. Draining of the physical model occurred at 3556 min

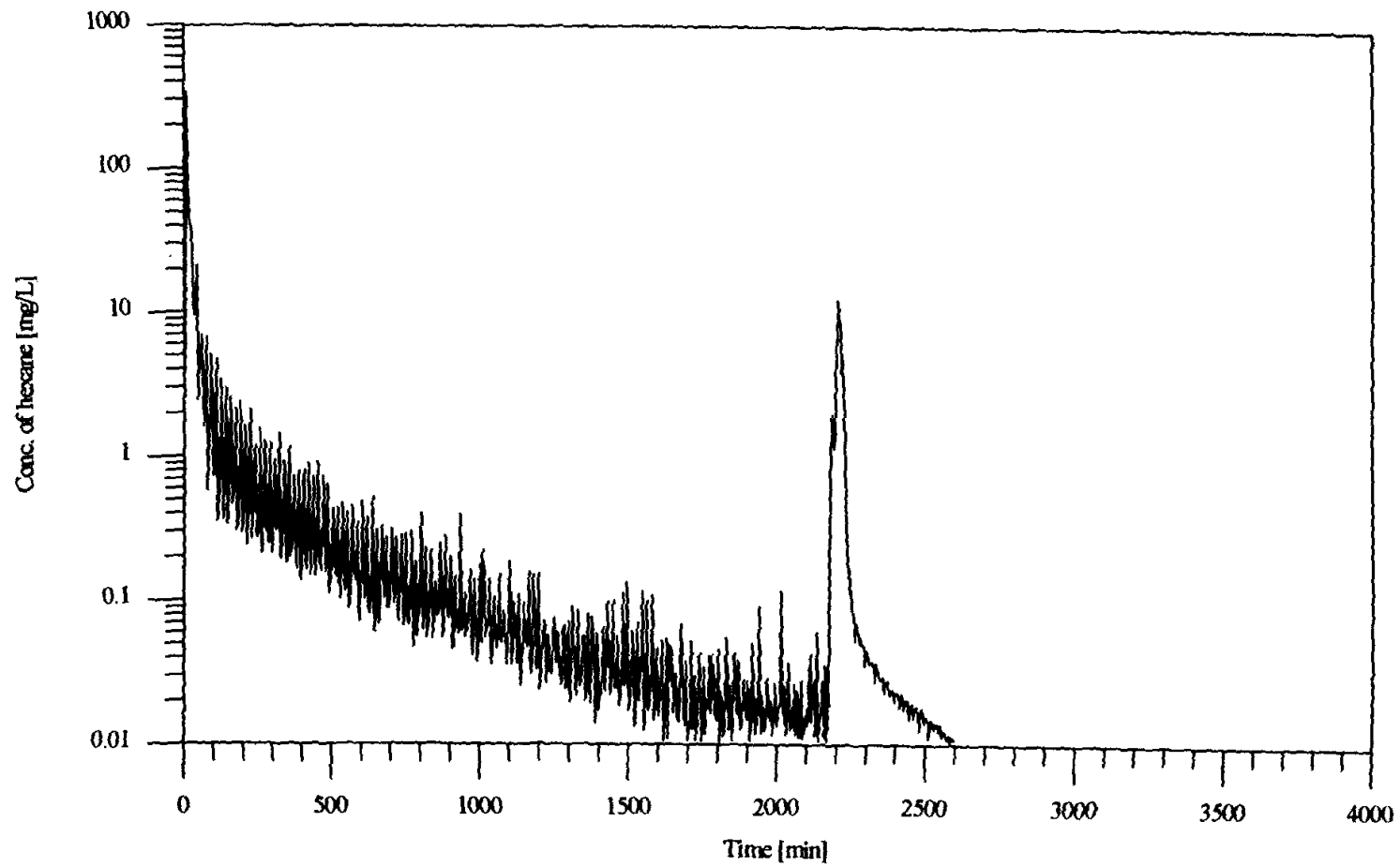

Figure 4.20: Hexane concentration in the outlet air of the physical model vs. time for $Q_{air} = 10$ L/min pulsed injection and $M = 33$ g., final wet medium experiment. Draining of the physical model occurred at 2174 min

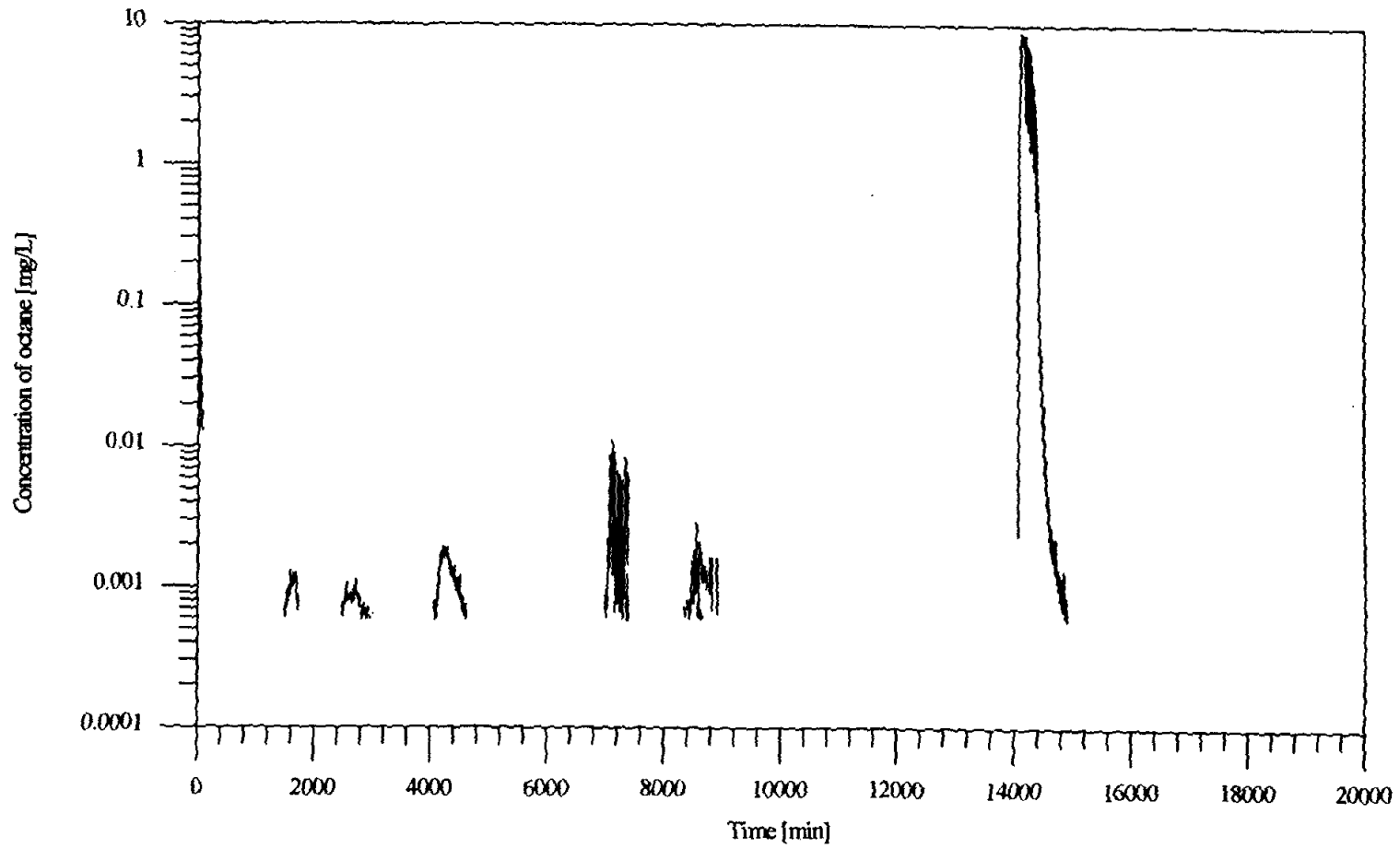

Figure 4.21: Octane concentration in the outlet air of the physical model vs. time for $Q_{air} = 10 \text{ L/min}$ both steady and pulsed injection and $Mf \approx 35.14 \text{ g.}$ out of air flow field wet medium experiment. Draining of the physical model occurred at 14012 min

CHAPTER 5

DATA ANALYSIS AND DISCUSSION

Table 5.1 presents a summary of the experiments conducted in this study. As a reminder, "preliminary", "intermediate", and "final" are simply labels assigned to three similar, but slightly different experimental protocols. Preliminary volatilization studies were conducted to assess the accuracy of the sampling and chemical analysis approach. Based upon the promising results from preliminary volatilization experiments, the intermediate approach was developed. Later it became obvious that the cumulative octane removal obtained from intermediate wet medium experiments was only a percentage of the total mass injected into the physical model. This led to the development of the "final" volatilization study protocol, which allowed better closure on the mass balance and facilitated the evaluation of the reproducibility of the volatilization experiments.

In the following, instantaneous removal rates and the cumulative mass removed are presented as a function of time. Instantaneous removal rates were calculated by multiplying the known air injection rates and measured vapor concentrations at any given time. In the case of pulsed air injection the vapor sample concentrations were multiplied by the time-averaged air injection flow rate (e.g., for the 10 L/min, 200-s on - 20-s off pulsing experiments the time-averaged flow rate is $10 \text{ L/min} \times 200 \text{ s} / (200 \text{ s} + 20 \text{ s}) = 9.1 \text{ L/min}$). Cumulative mass removals were calculated by integrating mass removal rates with time. In the following figures, cumulative mass removed is expressed as a percentage of the initial mass injected into the aquifer physical model. Also note that in each case individual data points are spaced four minutes apart; thus, the mass removal rate fluctuations seen in the figures are actually composed of

several data points.

Table 5.1. Summary of experiments conducted in this study.

Experiment #	Chemical	Media	Air Flow Rate Q_{air} [L/min]	Pulsed (Yes/No)	Time Draining Occurred [min]	Injected Mass M^o [mg]
PRELIMINARY VOLATILIZATION STUDIES						
1	Octane	Dry	11	N	-	7030
2	Octane	Dry	11	N	-	7030
3	Octane	Wet	11	N	-	7030
INTERMEDIATE VOLATILIZATION STUDIES						
4	Octane	Dry	1.25	N	-	35140
5	Octane	Wet	1.25	N	-	35140
6	Octane	Dry	10	N	-	35140
7	Octane	Wet	10	N	-	35140
8	Octane	Dry	10	Y	-	35140
9	Octane	Wet	10	Y	-	35140
18	Hexane	Dry	10	N	-	33000
FINAL VOLATILIZATION STUDIES						
10	Octane	Wet	1.25	N	3347	35140
11	Octane	Wet	1.25	N	5656	35140
12	Octane	Wet	10	N	7105	35140
13	Octane	Wet	10	N	3335	35140
14	Octane	Wet	10	N	4664	35140
15	Octane	Wet	10	Y	6983	35140
16	Octane	Wet	10	Y	4016	35140
17	Octane	Wet	10	Y	4184	35140
19	Hexane	Wet	10	N	3556	33000
20	Hexane	Wet	10	Y	2174	33000
SOURCE LOCATED AWAY FROM THE AIR FLOW FIELD						
21	Octane	Wet	10	Both pulsed and steady	14012	35140

Dry medium octane volatilization experiments

In Figures 5.1 through 5.5, instantaneous removal rates and cumulative octane removal are presented for the dry medium experiments. One might consider the behavior observed to be representative of soil vapor extraction systems under ideal conditions. With the exception of the steady 1.25 L/min experiment results shown in Figure 5.3, more than 80% of the initial octane mass is removed in the first 200 min. For an air flow rate of 1.25 L/min, the time taken for 80% octane removal was about 1600 min. Note that this observation is consistent with the conceptual model that assumes that removal rates for contaminants lying in contact with the air flow field should be proportional to the air injection rate, compound molecular weight, and compound vapor pressure. In this case, the time for removal is about eight times longer when the air injection rate is reduced by 1/8 from 10 L/min to 1.25 L/min. The peak mass removal rates for the 10 L/min results shown in Figures 5.4 and 5.5 (steady and pulsed conditions, respectively) are similar and roughly eight times the peak removal rate seen in Figure 5.3 for the 1.25 L/min air injection flow rate results.

In general Figures 5.1 through 5.5 exhibit relatively constant removal rates at the beginning of each experiment, and ~ 80% of the injected octane is typically removed in this period. After that time the removal rate decreases rapidly by one to three orders of magnitude. During the course of the entire experiment the removal rate vs. time curves are relatively "smooth" for all flow rates and flow conditions in the sense that no large fluctuations are observed. Pulsed air injection results presented in Figure 5.5 exhibit comparable behavior to the steady injection flow rate results (both at 10 L/min air injection flow rate), with the exception that periodic fluctuations are observed in the removal rate. At this time, there is not an obvious explanation for these fluctuations and their apparent periodicity.

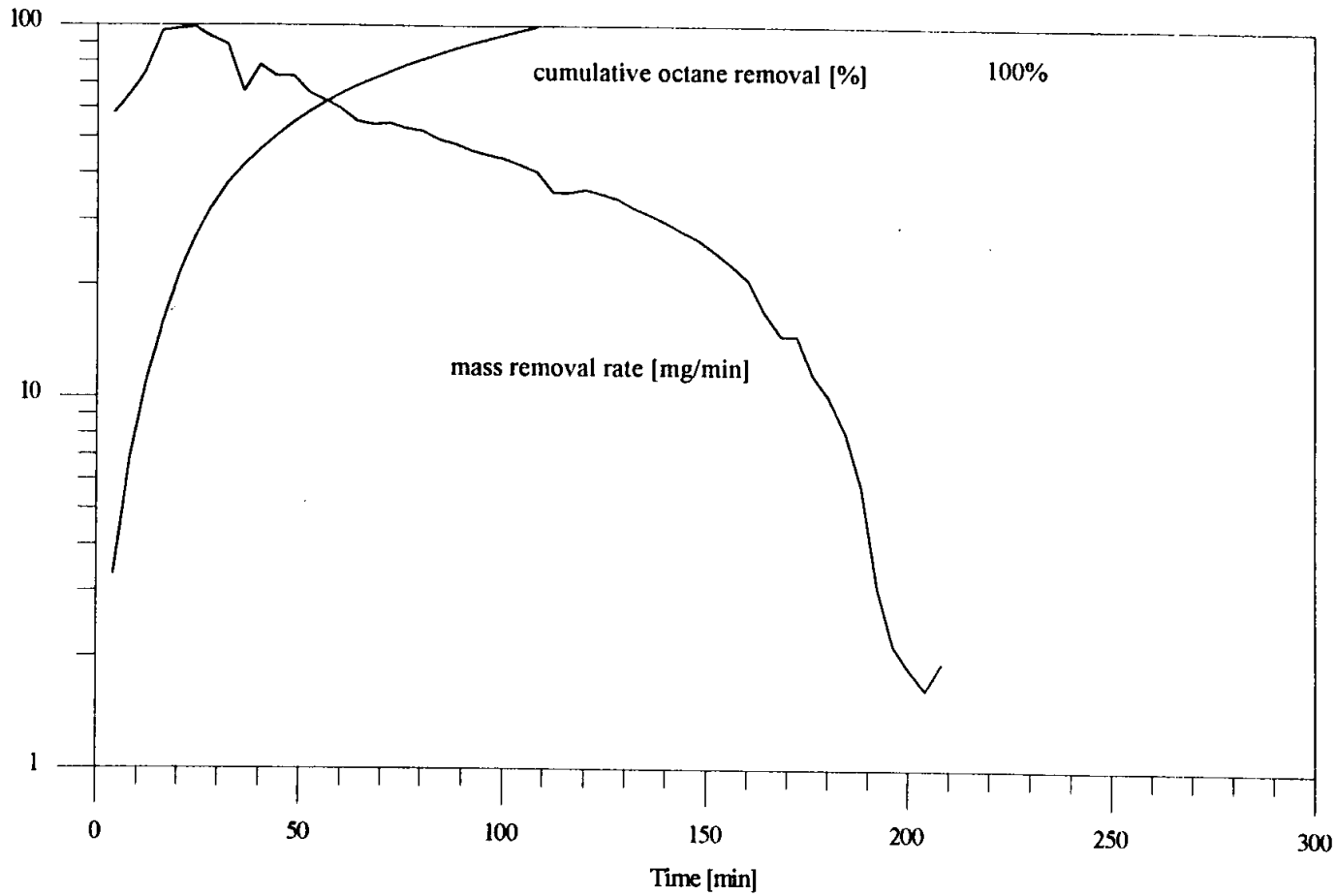

Figure 5.1: Mass removal rate and cumulative octane removal vs. time for $Q_{air} = 11$ L/min steady injection and $M^* = 7.03$ g., preliminary dry medium experiment.

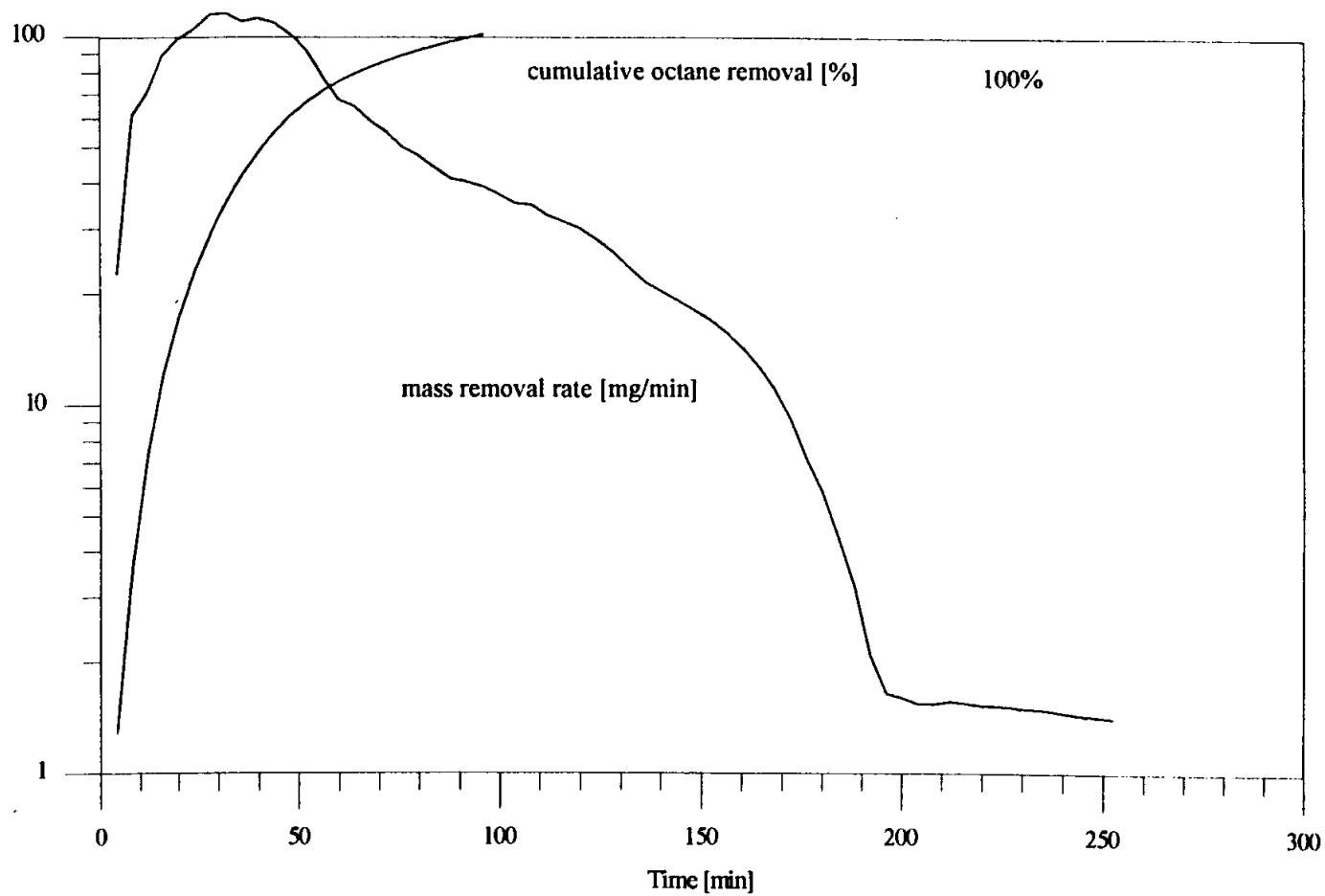

Figure 5.2: Mass removal rate and cumulative octane removal vs. time for $Q_{air} = 11$ L/min steady injection and $M^0 = 7.03$ g., preliminary dry medium experiment.

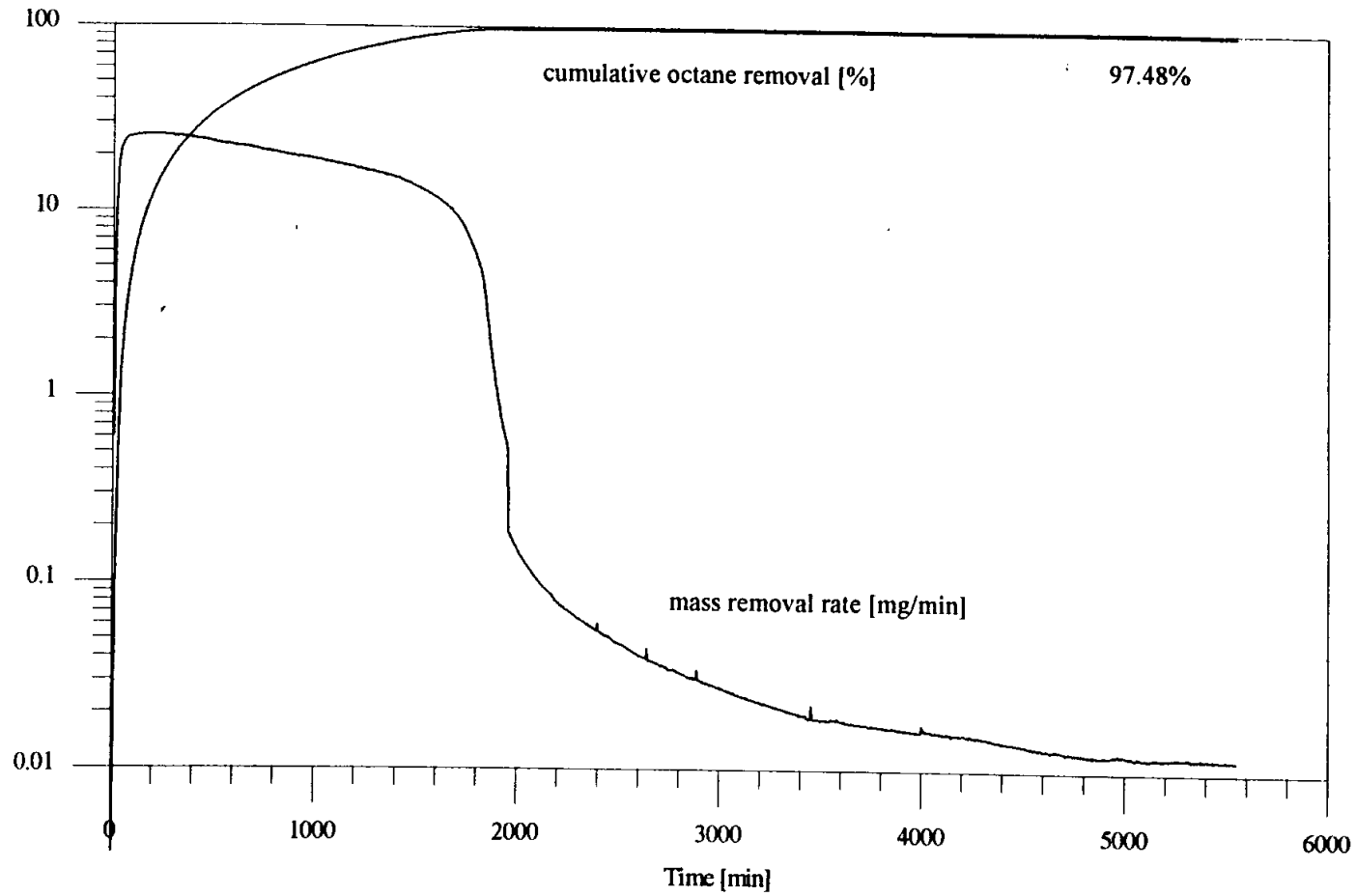

Figure 5.3: Mass removal rate and cumulative octane removal vs. time for $Q_{air} = 1.25$ L/min steady injection and $M^f = 35.14$ g., intermediate dry medium experiment.

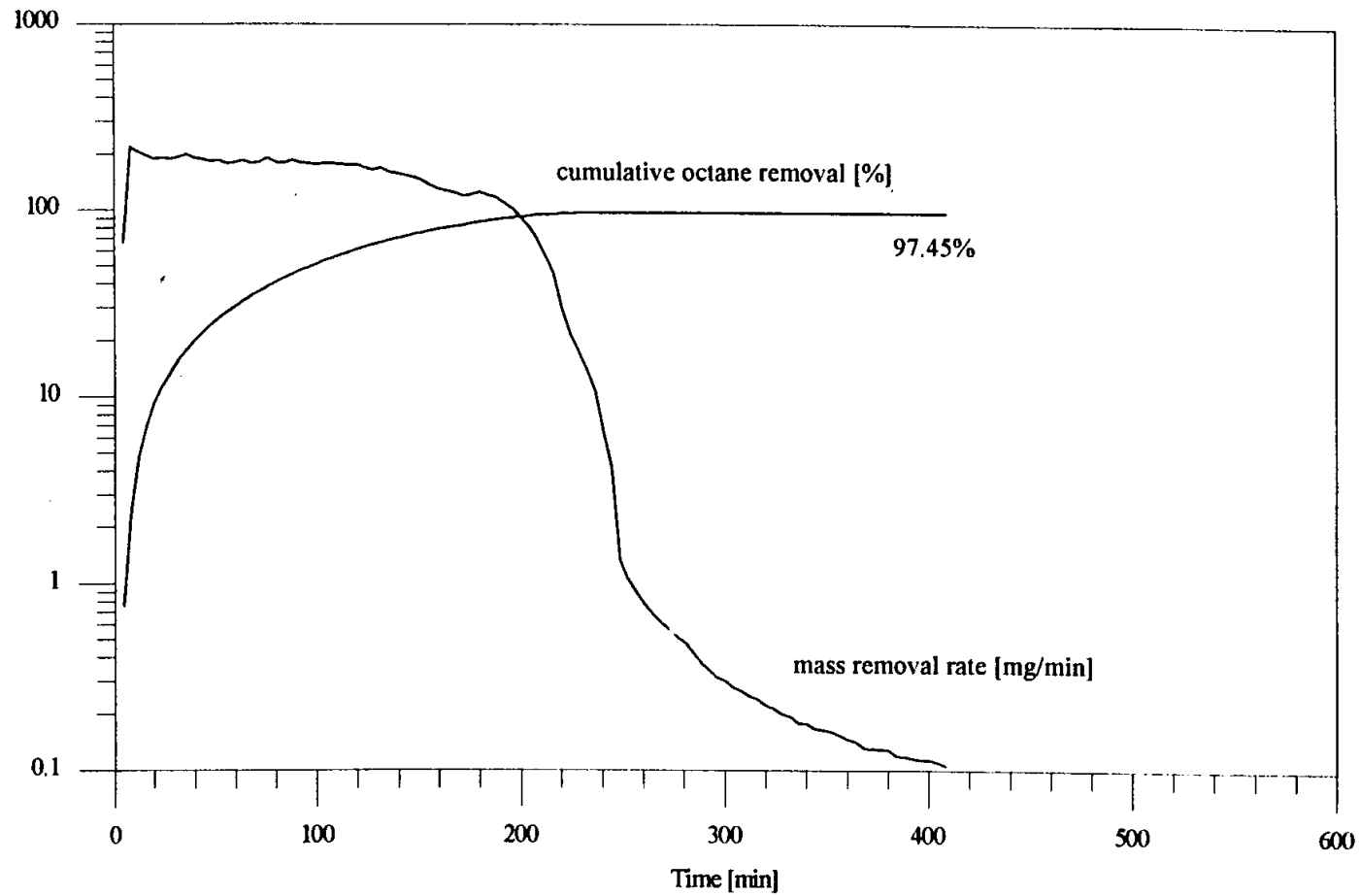

Figure 5.4: Mass removal rate and cumulative octane removal vs. time for $Q_{air} = 10$ L/min steady injection and $M^f = 35.14$ g., intermediate dry medium experiment.

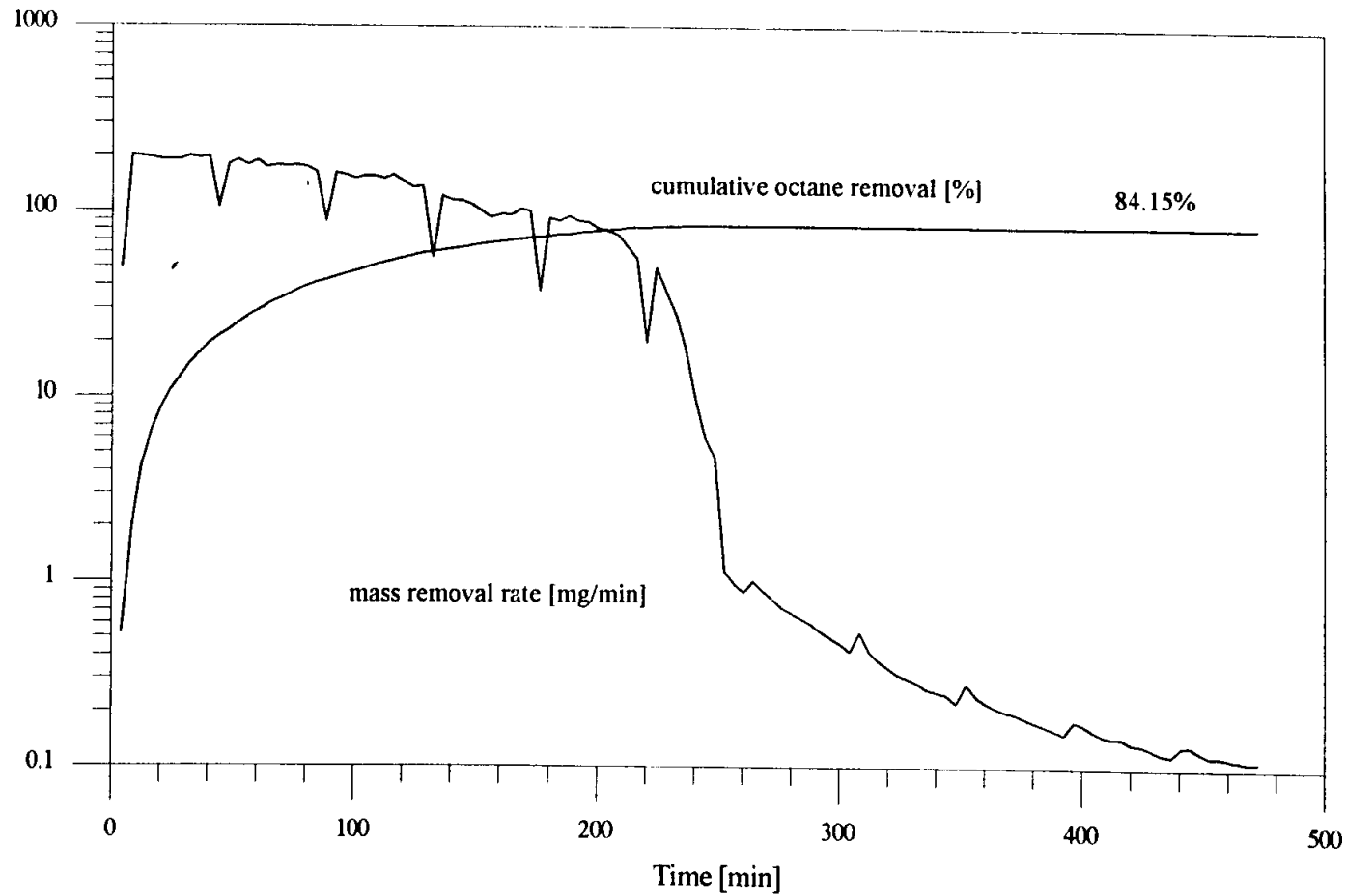

Figure 5.5: Mass removal rate and cumulative octane removal vs. time for $Q_{air} = 10$ L/min pulsed injection and $M^* = 35.14$ g., intermediate dry medium experiment.

Wet medium experiments using octane

Figures 5.6 through 5.17 present calculated mass removal rates vs. time and cumulative mass removal (expressed as a percentage of the initial mass injected) vs. time for the wet medium octane removal experiments. Figures 5.6, 5.7, 5.10 and Figure 5.14 correspond to results generated during the preliminary and intermediate stages of this work. All others correspond to experiments conducted using the "final" experimental protocol. Only the experiments conducted using the final protocol have closure on the mass balances. This was achieved by lowering the water table at the end of each experiment to allow any remaining mass to be volatilized and quantified. By "closure" we mean that all materials that can be removed by volatilization are removed from the aquifer physical model. It does not mean that all of the mass has been accounted for, and the reader will note that cumulative mass balances for wet media studies often did not account for 10% - 20% of the initial mass, while cumulative mass balances generally accounted for >98% of the initial mass during the dry media volatilization studies. Thus, the data suggest the possibility of other removal mechanisms occurring, the most likely being biodegradation. This is examined later in this chapter.

In general the wet media results exhibit the same qualitative behavior as was observed in the dry media volatilization studies. The mass removal rates are greatest at the beginning of the experiment and then they decline, with the rate of decline itself decreasing with time. Table 5.2 summarizes key characteristics of selected volatilization experiments, including the peak removal rates. The peak mass removal rates are comparable in magnitude to those observed in Figures 5.1 through 5.5 for the dry media experiments and equivalent flow rates. This would be consistent with our conceptual model in which removal occurs first from the air flow channels in the same manner that removal occurs in a dry medium, and then mass

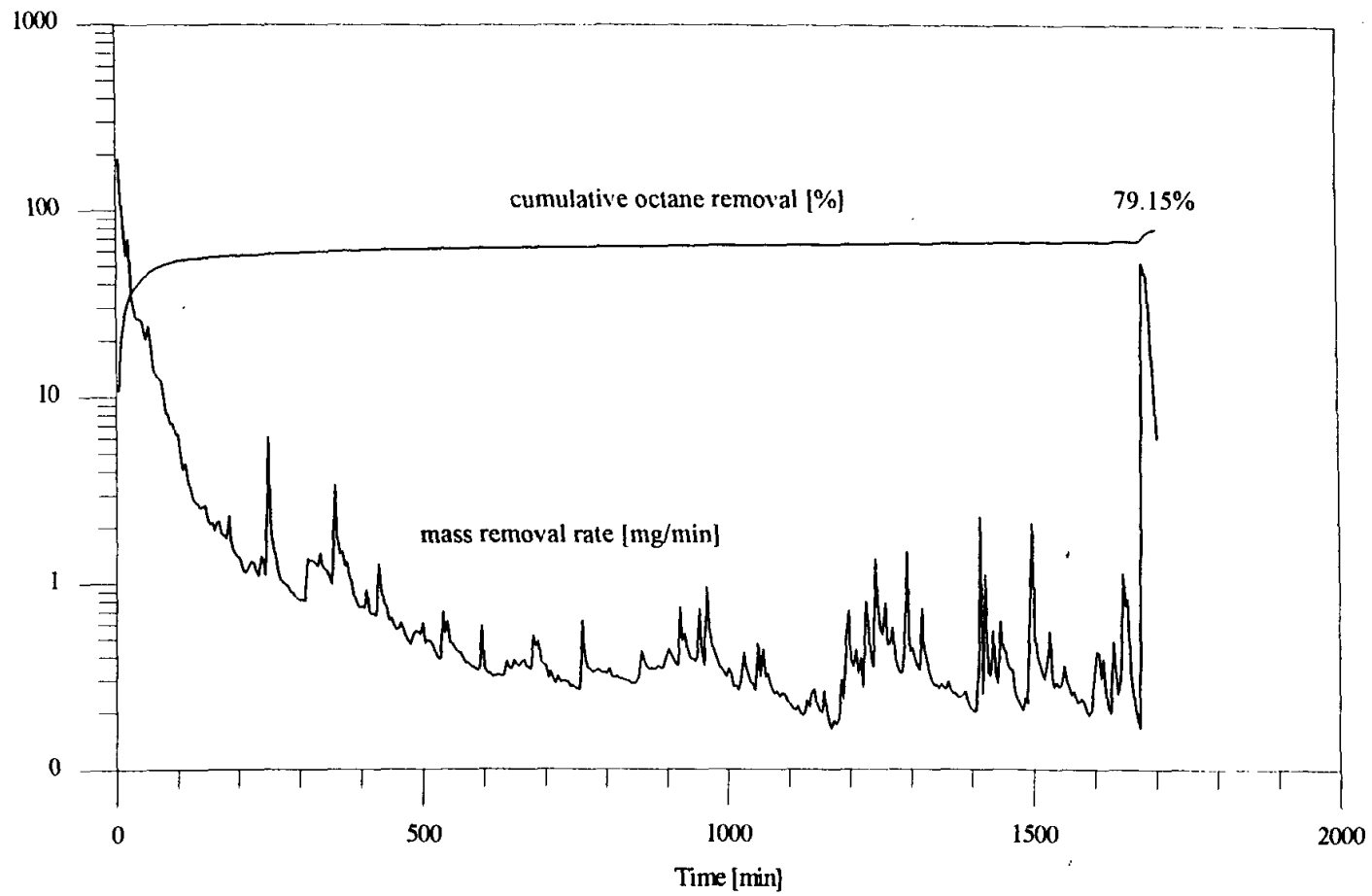

Figure 5.6: Mass removal rate and cumulative octane removal vs. time for $Q_{air} = 11$ L/min steady injection and $M^p = 7.03$ g., preliminary wet medium experiment.

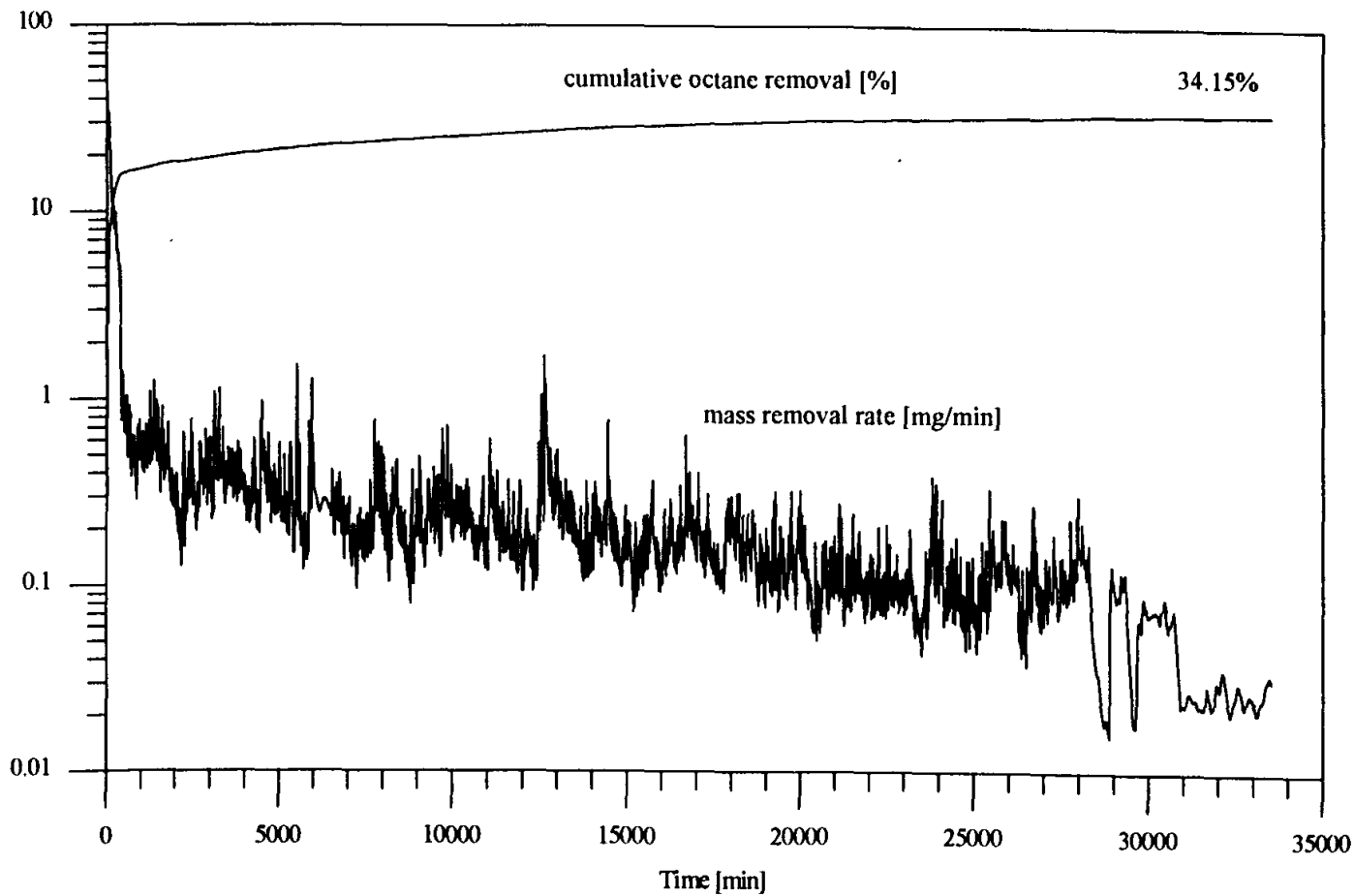

Figure 5.7: Mass removal rate and cumulative octane removal vs. time for $Q_{air} = 1.25$ L/min steady injection and $M^P = 35.14$ g., intermediate wet medium experiment.

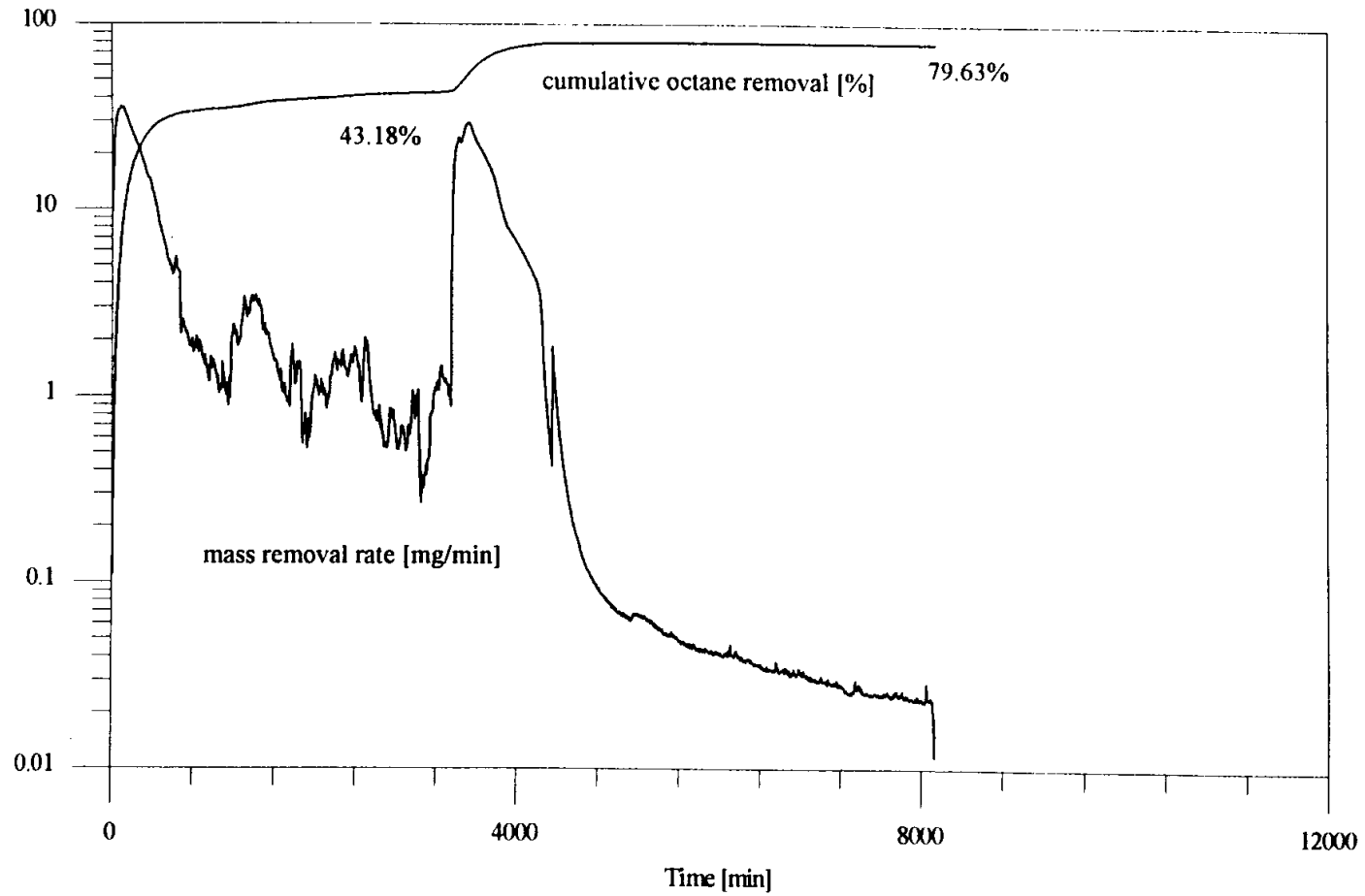

Figure 5.8: Mass removal rate and cumulative octane removal vs. time for $Q_{air} = 1.25$ L/min steady injection and $\Lambda P = 35.14$ g., final wet medium experiment. Draining of the physical model occurred at 3347 min

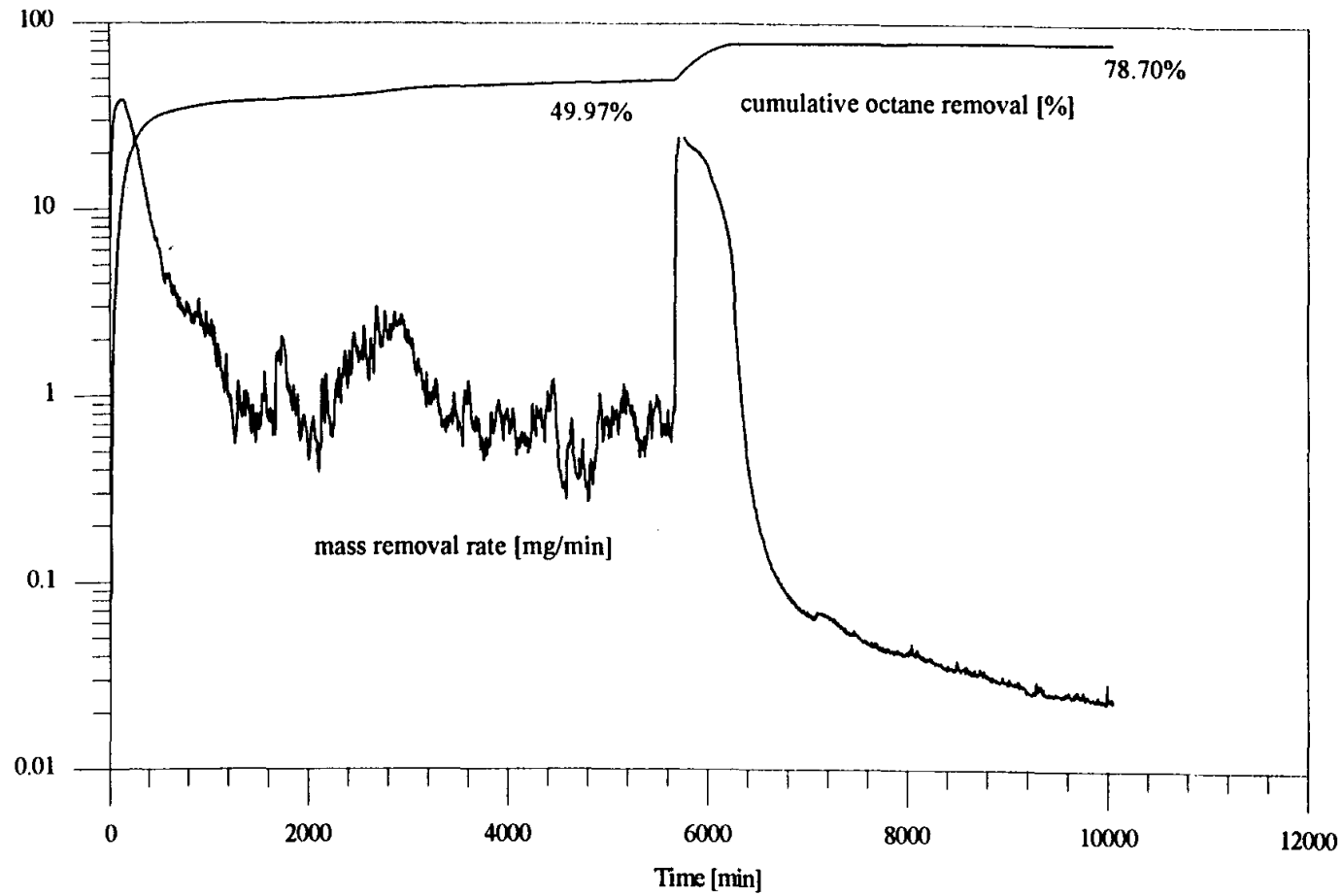

Figure 5.9: Mass removal rate and cumulative octane removal vs. time for $Q_{air} = 1.25$ L/min steady injection and $M^f = 35.14$ g., final wet medium experiment. Draining of the physical model occurred at 5656 min.

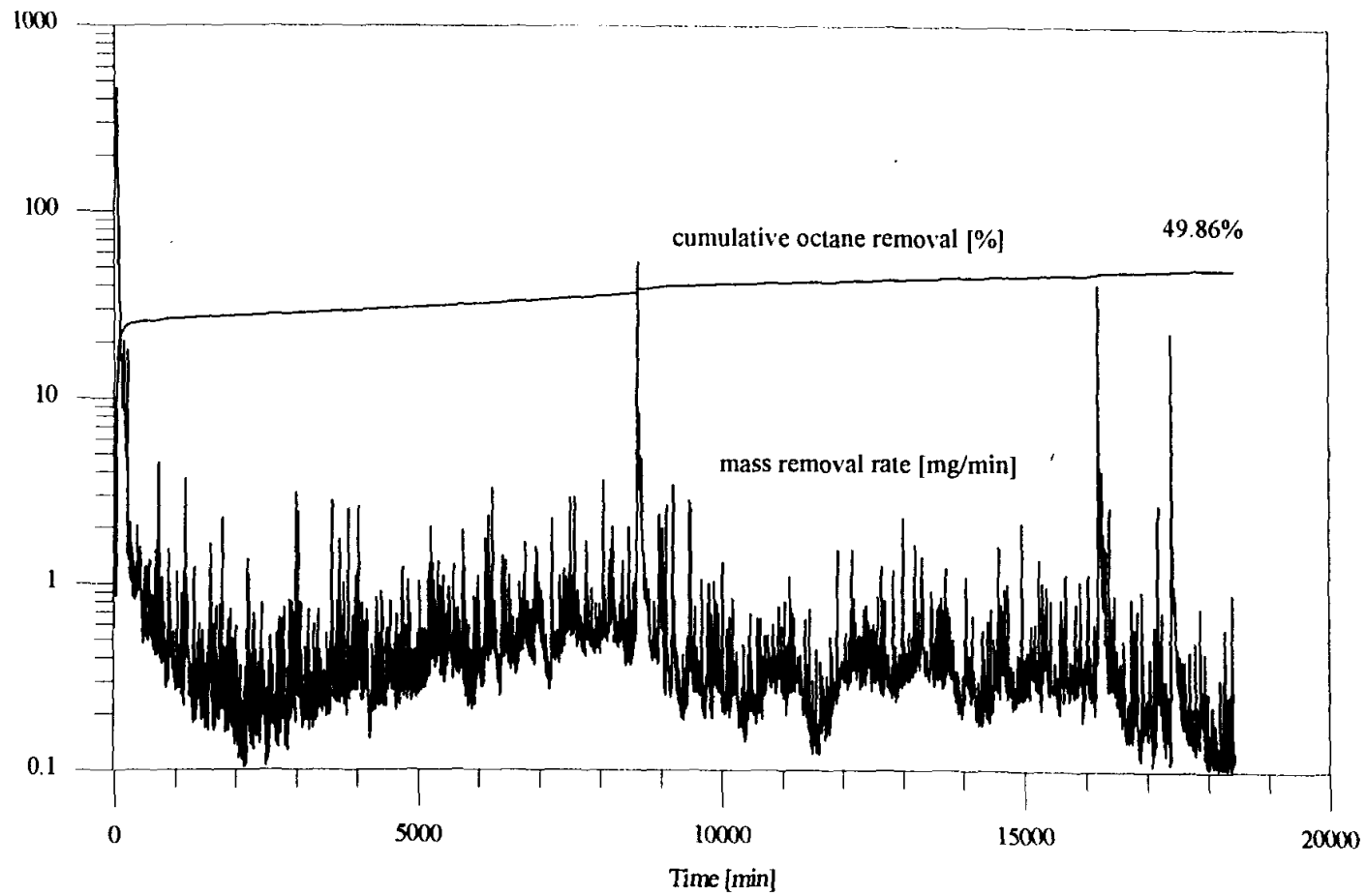

Figure 5.10: Mass removal rate and cumulative octane removal vs. time for $Q_{air} = 10$ L/min steady injection and $M^p = 35.14$ g., intermediate wet medium experiment.

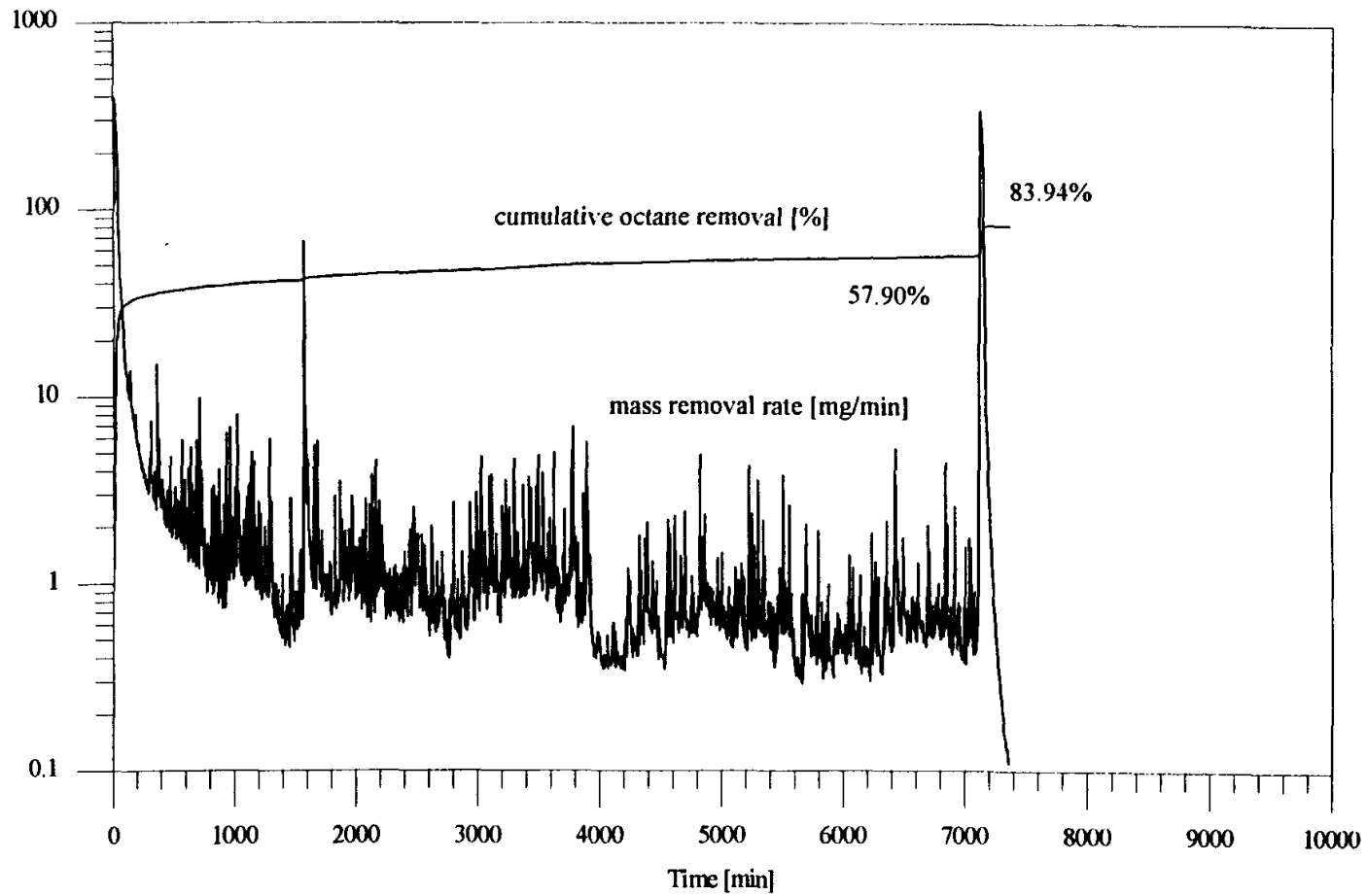

Figure 5.11: Mass removal rate and cumulative octane removal vs. time for $Q_{air} = 10$ L/min steady injection and $M^f = 35.14$ g., final wet medium experiment. Draining of the physical model occurred at 7105 min.

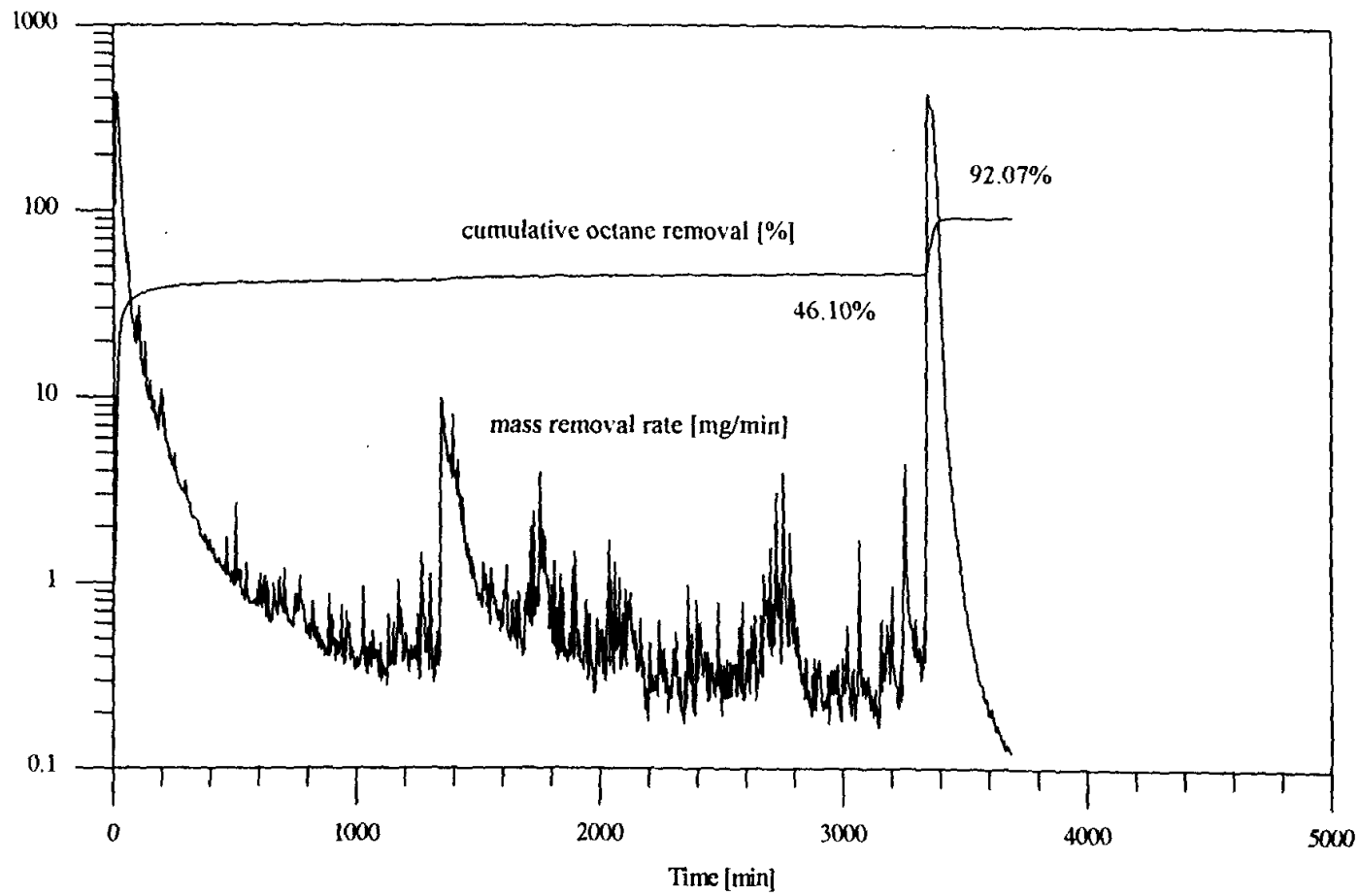

Figure 5.12: Mass removal rate and cumulative octane removal vs. time for $Q_{air} = 10$ L/min steady injection and $M^0 = 35.14$ g., final wet medium experiment. Draining of the physical model occurred at 3335 min.

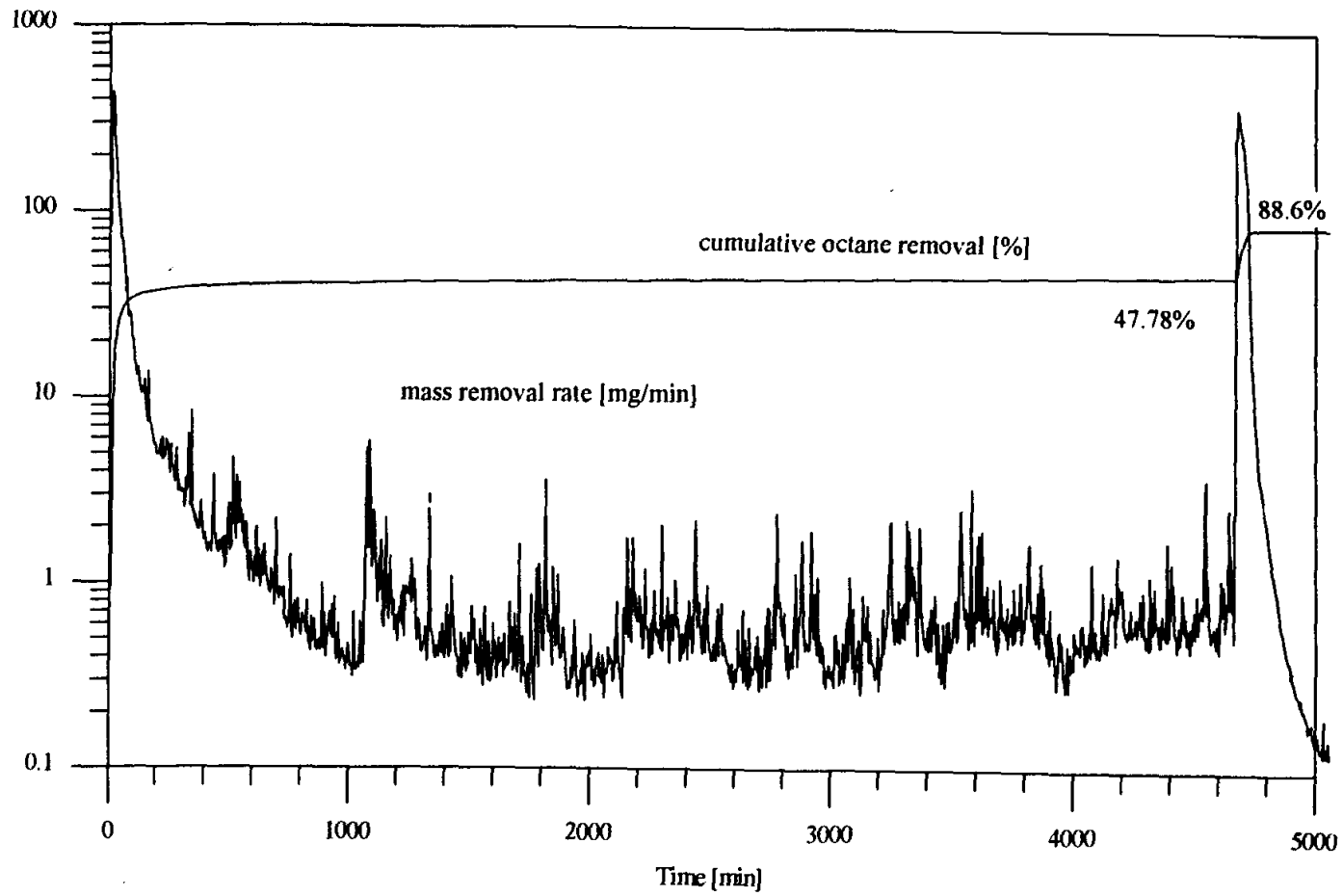

Figure 5.13: Mass removal rate and cumulative octane removal vs. time for $Q_{air} = 10$ L/min steady injection and $M = 35.14$ g., final wet medium experiment. Draining of the physical model occurred at 4664 min.

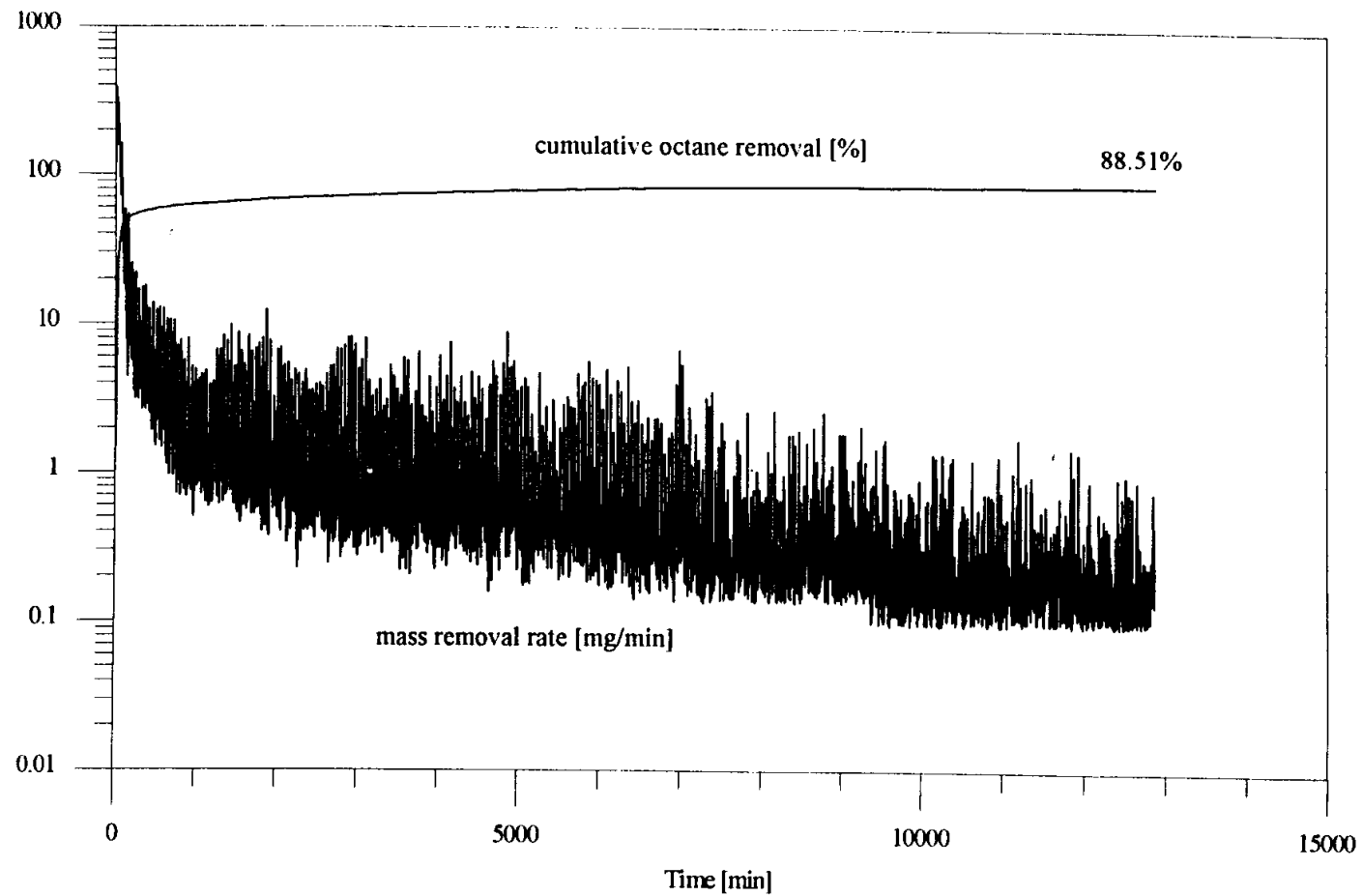

Figure 5.14: Mass removal rate and cumulative octane removal vs. time for $Q_{air} = 10$ L/min pulsed injection and $M^f = 35.14$ g., intermediate wet medium experiment.

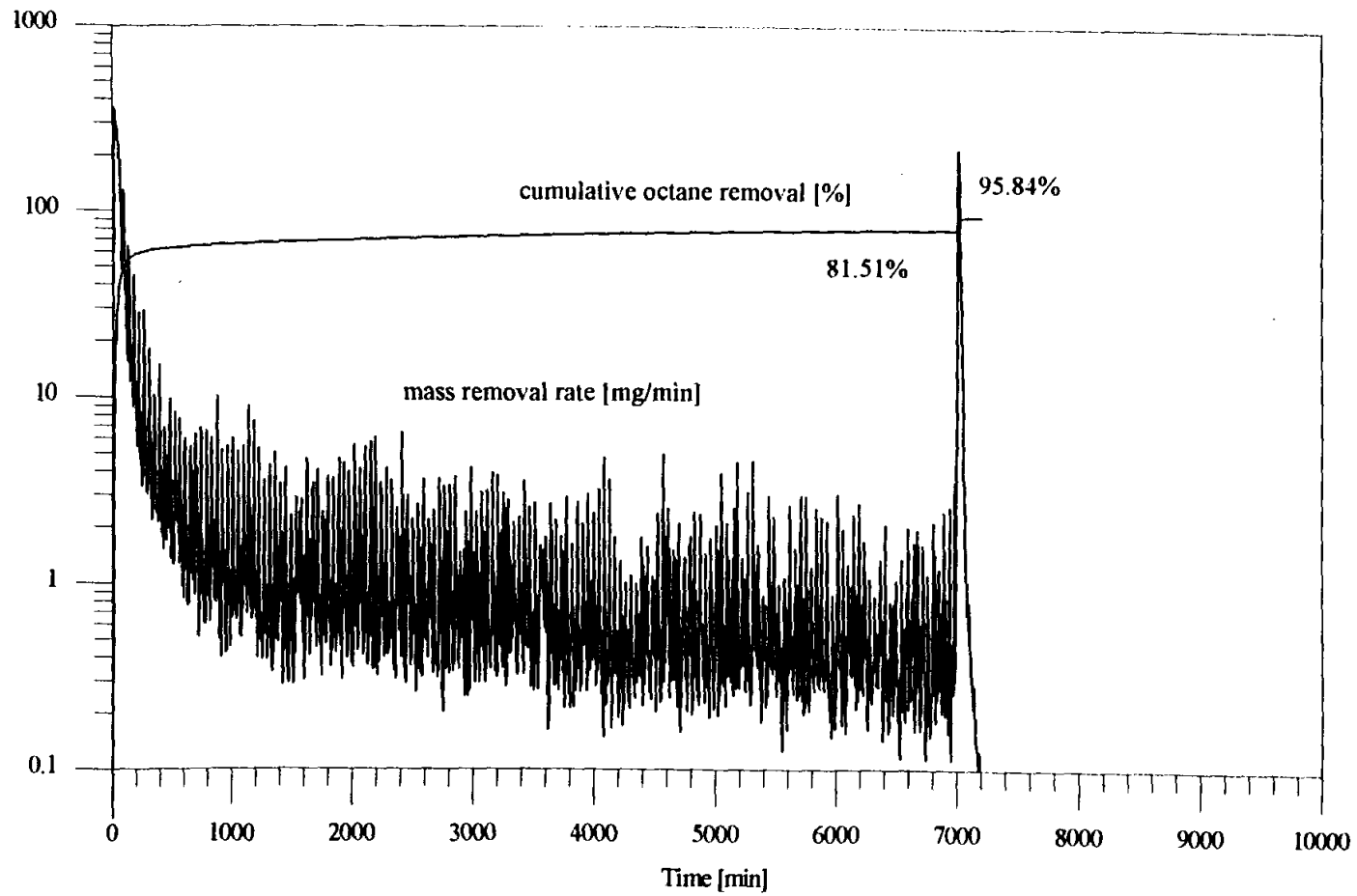

Figure 5.15: Mass removal rate and cumulative octane removal vs. time for $Q_{air} = 10$ L/min pulsed injection and $M^0 = 35.14$ g., final wet medium experiment. Draining of the physical model occurred at 6983 min.

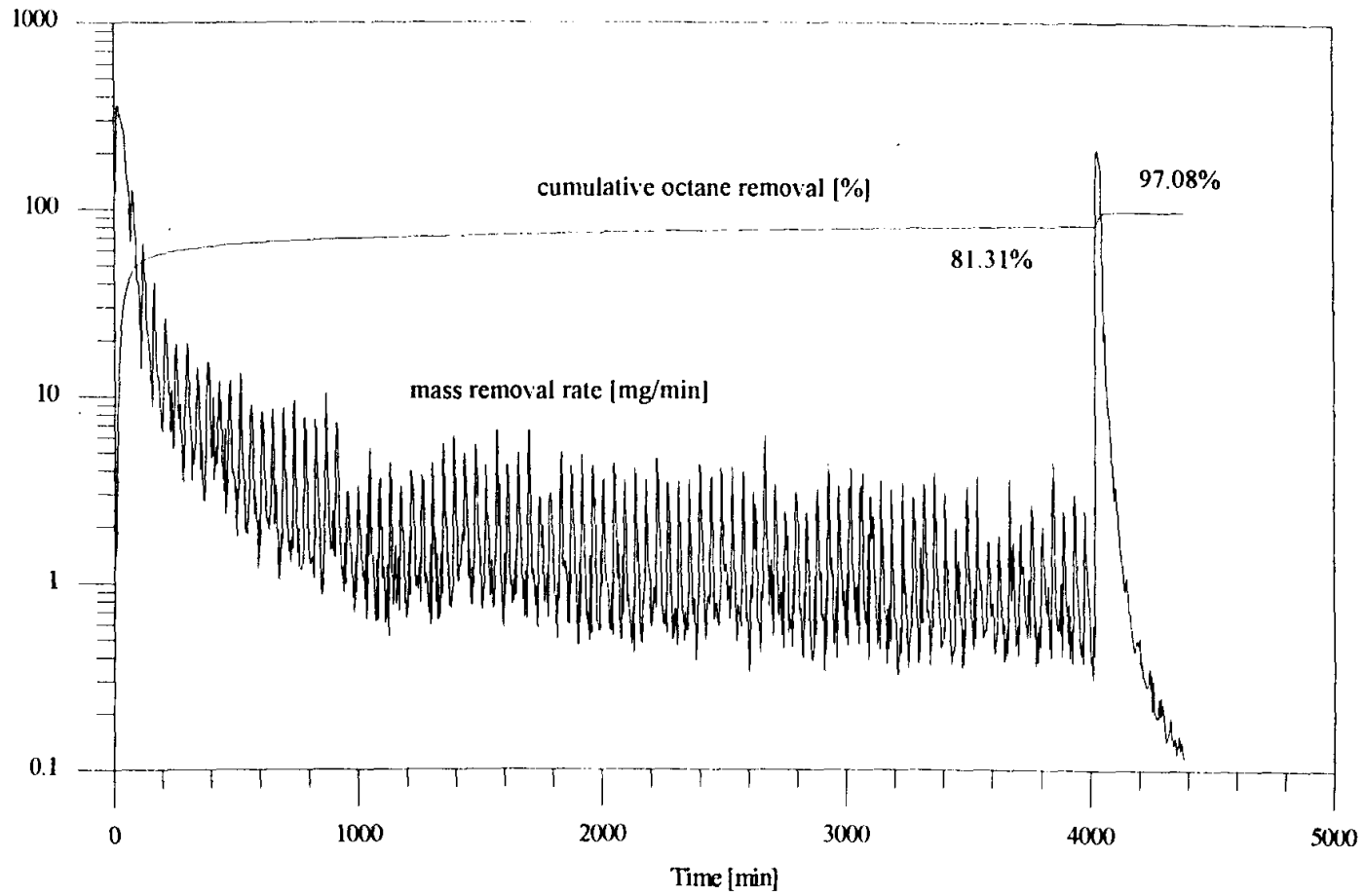

Figure 5.16: Mass removal rate and cumulative octane removal vs. time for $Q_{air} = 10$ L/min pulsed injection and $M^l = 35.14$ g., final wet medium experiment. Draining of the physical model occurred at 4016 min.

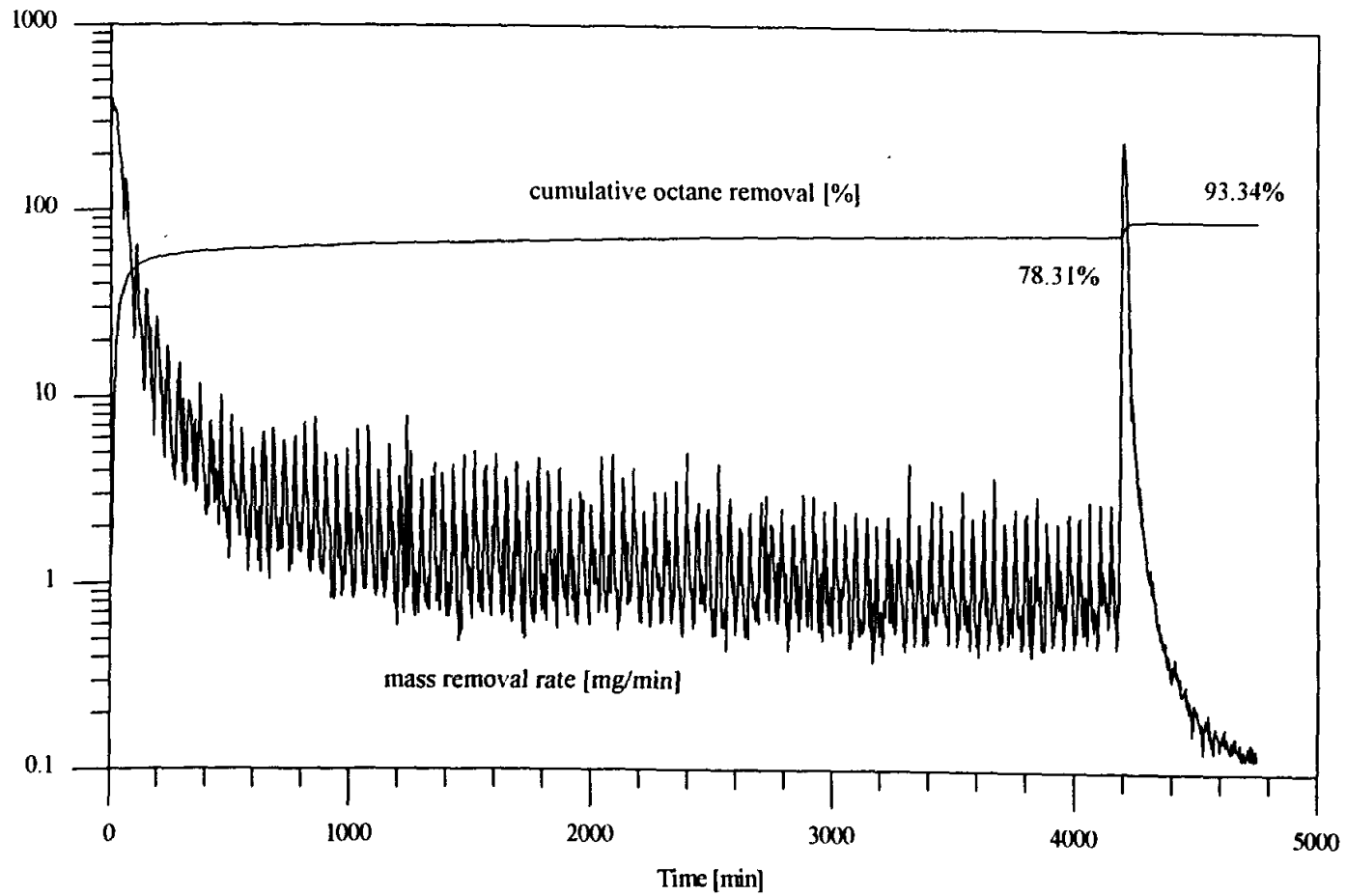

Figure 5.17: Mass removal rate and cumulative octane removal vs. time for $Q_{air} = 10$ L/min pulsed injection and $M^P = 35.14$ g., final wet medium experiment. Draining of the physical model occurred at 4184 min.

Table 5.2: Summary of key characteristics of selected volatilization experiments.

Expt. #	Chemical	Media	Air Flow Rate Q_{air}	Pulsed	Injected Mass M°	Peak Mass Removal Rate	% Removed by $t=2000$ min	% Removed Prior to Draining	Mass Removal Rate Just Prior To Drain	Time Draining Occured	Total Mass Recovered
			[L/min]	(Y/N)	[mg]	[mg/min]			[mg/min]	[min]	[%]
PRELIMINARY VOLATILIZATION STUDIES											
1	Octane	Dry	11	N	7030	99	100	-	-	-	100
2	Octane	Dry	11	N	7030	116	100	-	-	-	100
INTERMEDIATE VOLATILIZATION STUDIES											
4	Octane	Dry	1.25	N	35140	25	71	-	-	-	97
6	Octane	Dry	10	N	35140	220	97	-	-	-	97
8	Octane	Dry	10	N	35140	200	84	-	-	-	84
18	Hexane	Dry	10	Y	33000	3483	99	-	-	-	99
FINAL VOLATILIZATION STUDIES											
10	Octane	Wet	1.25	N	35140	36	39	43	1.03	3347	80
11	Octane	Wet	1.25	N	35140	39	40	50	0.73	5656	79
12	Octane	Wet	10	N	35140	394	45	58	0.58	7105	84
13	Octane	Wet	10	N	35140	431	44	46	0.41	3335	92
14	Octane	Wet	10	N	35140	437	43	48	0.70	4664	89
15	Octane	Wet	10	N	35140	358	70	82	0.88	6983	96
16	Octane	Wet	10	Y	35140	360	74	81	0.58	4016	97
17	Octane	Wet	10	Y	35140	362	70	78	0.80	4184	93
19	Hexane	Wet	10	N	33000	2351	82	85	0.17	3556	93
20	Hexane	Wet	10	Y	33000	3111	87	82	0.20	2174	94
SOURCE LOCATED AWAY FROM THE AIR FLOWFIELD											
21	Octane	Wet	10	Both steady and pulsed	35140	9	0.29	0.35	0	14012	42

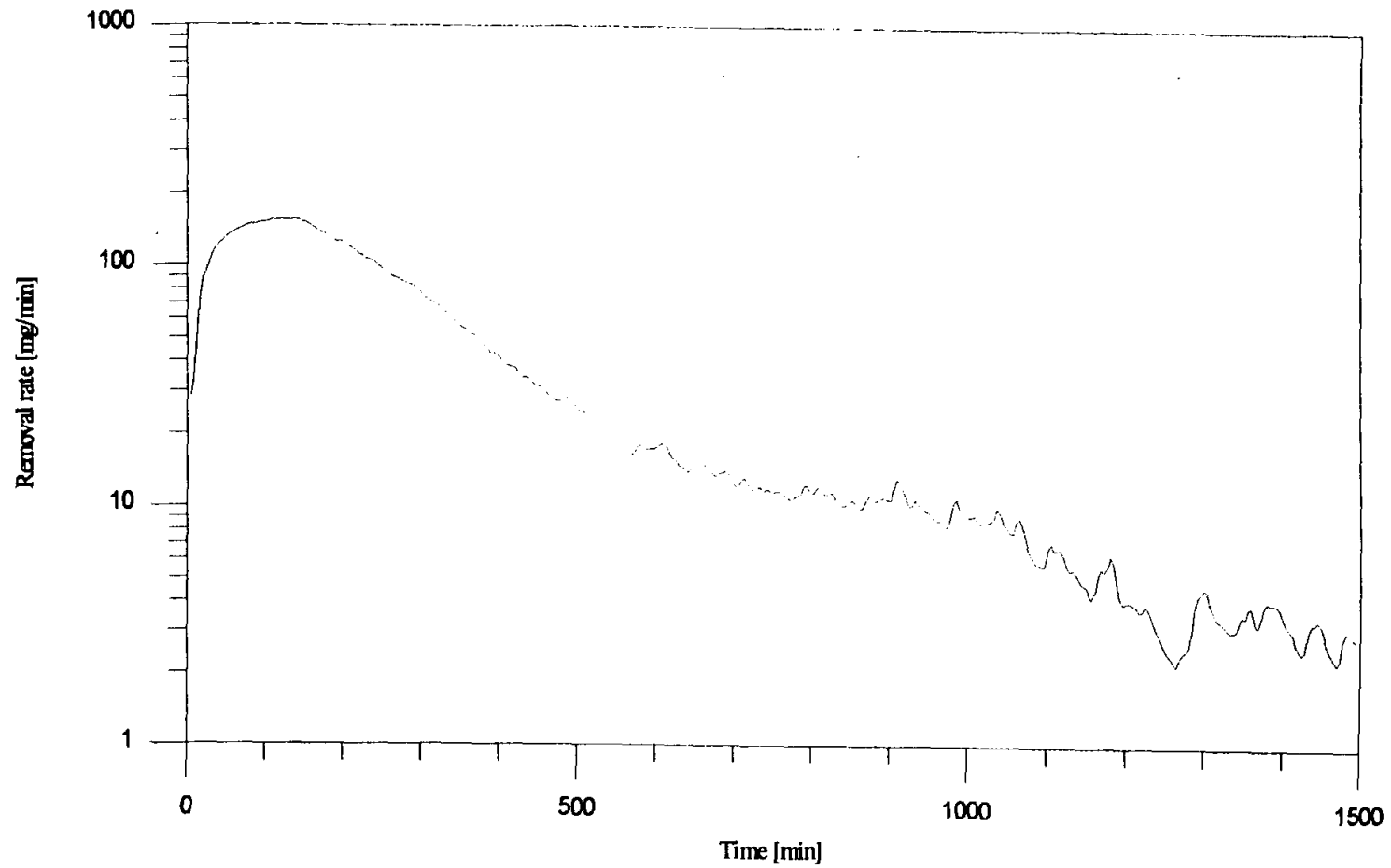

Figure 5.18: A close look at the short term removal rate of octane vs. time for $Q_{air} = 1.25$ L/min steady injection and $M^0 = 35.14$ g.

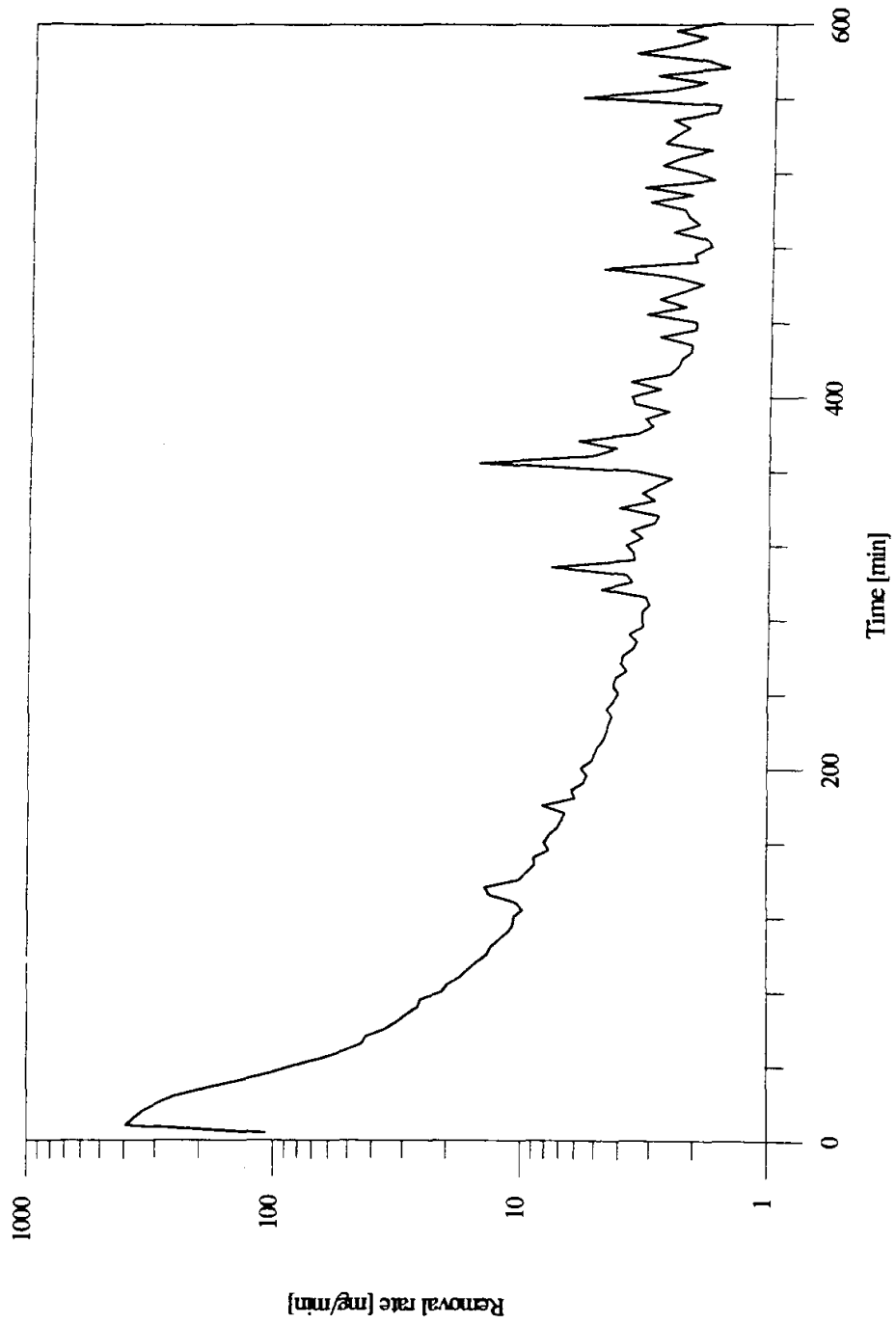

Figure 5.19: A close look at the short term removal rate of octane vs. time for $Q_{\text{air}} = 10 \text{ L/min}$ steady injection and $M = 35.14 \text{ g}$.

Dry medium experiment using n-hexane

In Figure 5.20 the instantaneous removal rate and cumulative removal of n-hexane expressed as a percentage of the initial injected mass against time for dry medium are plotted. Qualitatively, the results are similar to those shown in Figures 5.1 and 5.2 for octane. For the case of a steady 10 L/min air flow rate, 99% of the initial injected mass (33 g or 50 mL n-hexane) was removed within the first 300 min. Similar experiments with n-octane (35 g or 50 mL) took a little longer than 400 min for complete removal. The difference is due to the higher initial removal rate of n-hexane, which in turn is due to its higher saturated vapor concentration. As Table 5.2 illustrates, peak mass removal rates for the hexane experiments are roughly an order of magnitude greater than those for octane. This is in agreement with our conceptual model that predicts peak removal rates being proportional to air flow rate, vapor pressure, and molecular weight. The theoretical ratio of peak mass removal rates is expected to be 0.12 (octane/hexane).

Wet medium experiments with variable air injection rate using n-hexane

Calculated instantaneous mass removal rates and the cumulative removal of n-hexane expressed as a percentage of the initial injected mass vs. time for wet media are plotted in Figures 5.21 and 5.22. The air flow rate was held steady at 10 L/min for the results shown in Figure 5.21 (expt. #19), while the air injection was pulsed (200-s on, 20-s off) in Figure 5.22 (expt. #20).

Here the results are again qualitatively similar to those previously presented for n-octane, with the exception that the initial mass removal rates are greater (which is attributed above to differences in

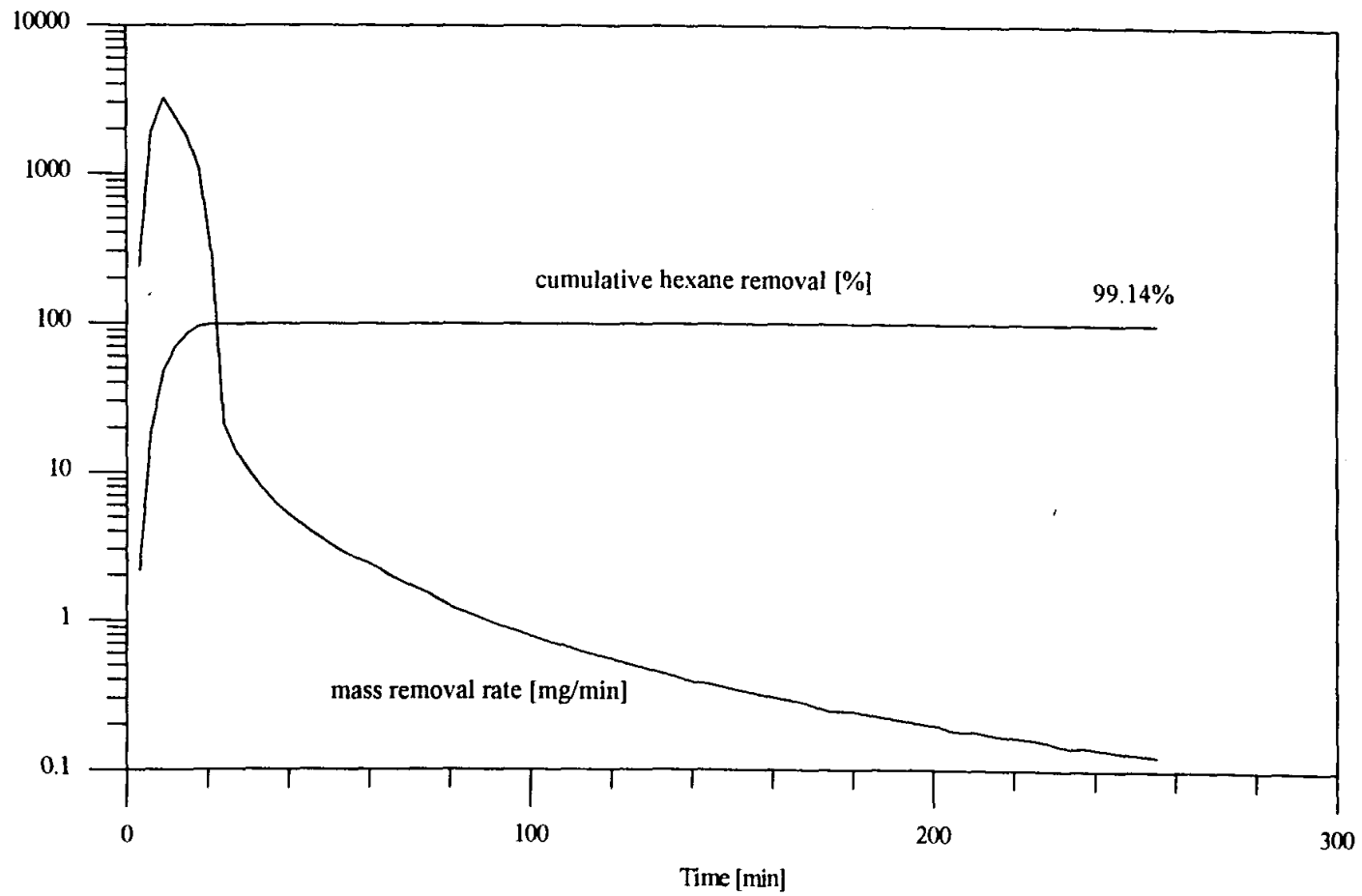

Figure 5.20: Mass removal rate and cumulative hexane removal vs. time for $Q_{air} = 10$ L/min steady injection and $M^p = 33$ g., intermediate dry medium experiment.

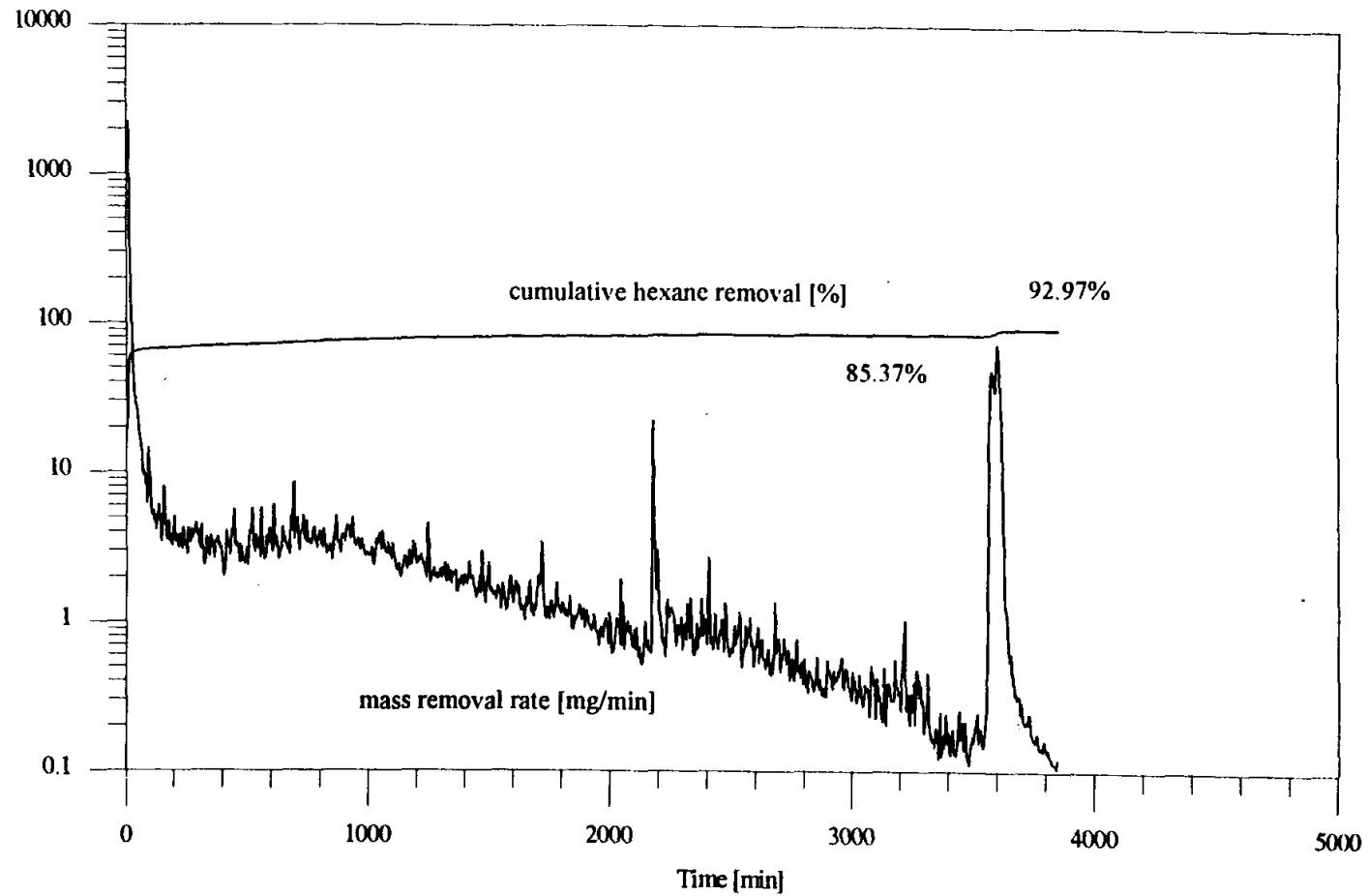

Figure 5.21: Mass removal rate and cumulative hexane removal vs. time for $Q_{air} = 10$ L/min steady injection and $M = 33$ g., final wet medium experiment. Draining of the physical model occurred at 3556 min.

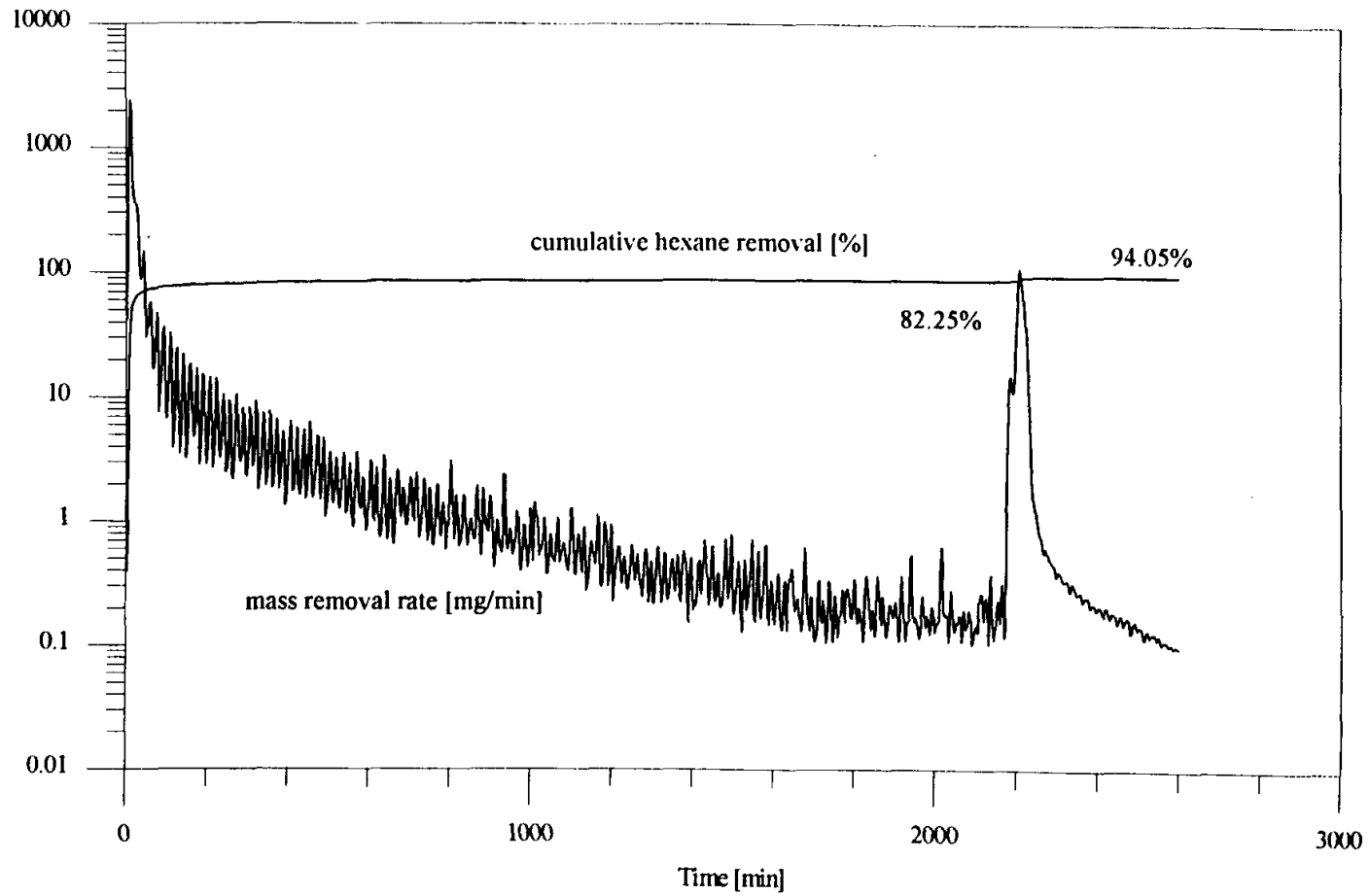

Figure 5.22: Mass removal rate and cumulative hexane removal vs. time for $Q_{air} = 10$ L/min pulsed injection and $M^p = 33$ g., final wet medium experiment. Draining of the physical model occurred at 2174 min.

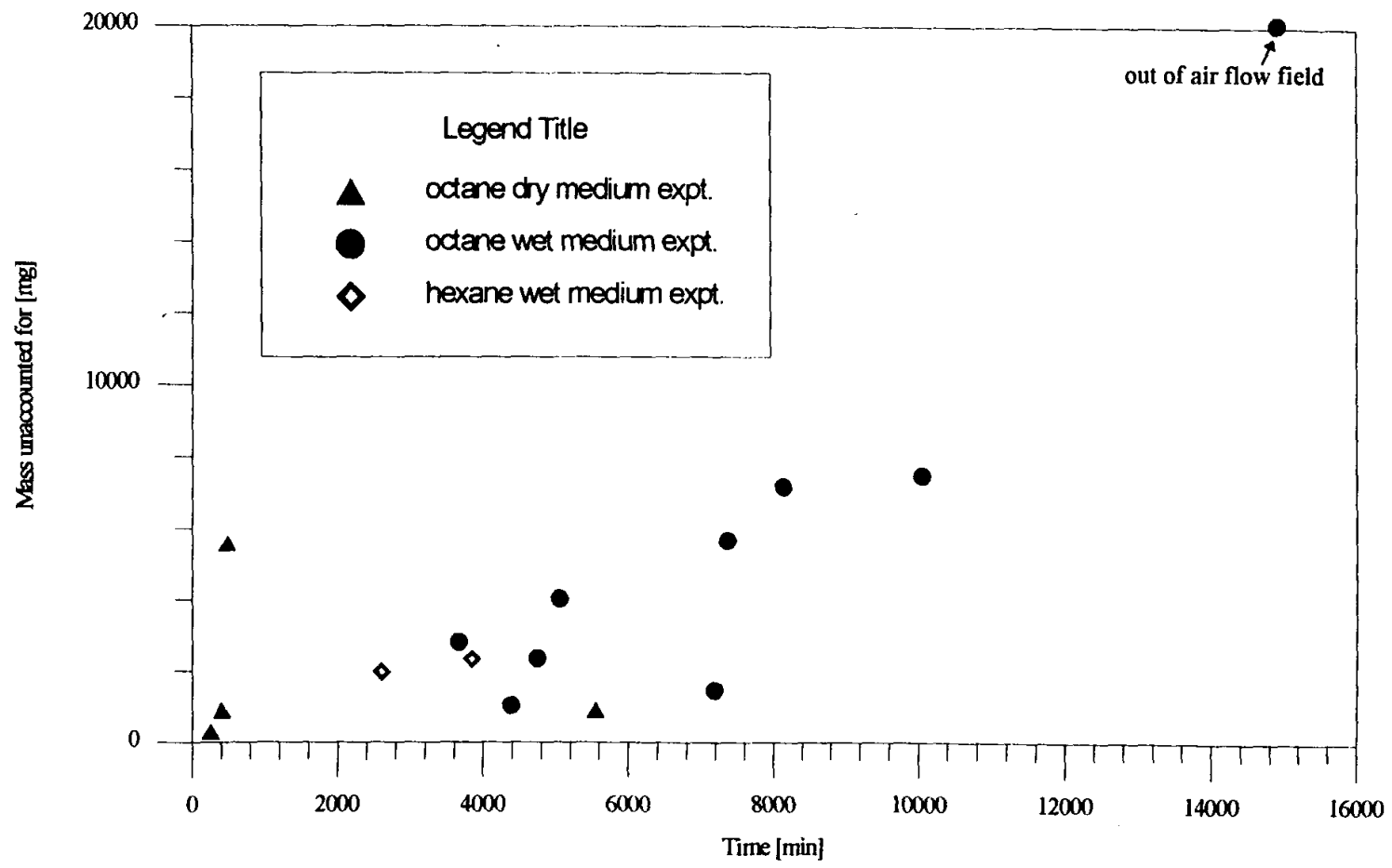

Figure 5.23: Mass unaccounted for in the final mass balance vs. time.

vapor pressure and molecular weight). Note, however, that the n-hexane cumulative removals are greater than those of the octane removal experiments, and also that there is relatively little difference between cumulative removals achieved during steady and pulsed air injection. In the case of n-octane, there was a significant difference between the cumulative removals achieved during pulsed and steady air injection studies. It is not clear why this should be the case. The conceptual model predicts that the initial cumulative removal should be similar if the air flow distribution is similar for both cases, yet the n-hexane removal is significantly greater than the n-octane, for the case of steady air injection. For the case of pulsed air injection the cumulative mass removal achieved is comparable.

Table 5.3. Cumulative removal of octane and hexane expressed as percentage of initial mass for both octane and hexane in wet medium under steady and pulsed conditions.

Time [min]	Steady Air Flow 10 [L/min]		Ratio	Pulsed air flow (200-s on, 20-s off) 10 [L/min]		Ratio
	Hexane	Octane	Octane/Hexane	Hexane	Octane	Octane/Hexane
10	52.98	9.14	0.17	29.88	8.14	0.27
20	61.94	18.12	0.29	59.73	16.07	0.26
30	63.27	25.64	0.39	66.96	26.75	0.41
60	65.38	31.77	0.47	73.77	42.04	0.56
90	66.28	34.34	0.52	75.98	50.07	0.66
120	66.95	36.00	0.54	77.40	53.01	0.68
150	67.38	37.12	0.55	78.52	55.31	0.70
180	67.84	37.78	0.55	79.46	57.05	0.72
210	68.19	38.50	0.55	80.23	58.31	0.73
240	68.51	38.90	0.58	80.86	59.11	0.73
1440	79.94	43.12	0.54	86.72	71.21	0.81
2500	84.06	44.96	0.53	94.03	76.28	0.81

For comparison, Table 5.3 shows the cumulative % removal at different times for both octane and hexane under steady and pulsed conditions. Hexane has both a higher vapor pressure (0.16 atm vs. 0.014 atm) and a higher solubility (13 mg/L vs 0.7 mg/L) than n-octane and one or the other might

account for the improved removal during steady air injection. The data is not sufficient to explain the increased performance with n-hexane.

Sources located away from the air flow field

Figure 5.23 shows the plot of calculated instantaneous mass removal rate and cumulative removal for the experiment where a 50-mL octane source was introduced at approximately 60 cm (2 ft) away from the air flow field, and then air injection was initiated in steady and pulsed modes, with and without horizontal water flow (see Chapter 4 for specific details on the protocol). Only 0.35% of the initial injected mass was removed before draining of the physical model on the 10th day (14012 min); less than half the total initial mass was accounted for in the mass balance. Cumulative removal could not be improved significantly by imposing water circulation in the physical model. This data suggests that in situ air sparging might not be effective at removing low-solubility residual/trapped immiscible contaminants from water-saturated zones unless they are located very close to air flow paths.

Sources of error for the experiments

There are a number of sources of error that affect the accuracy of the mass removal rate and cumulative mass removal calculations. The most significant of these are: a) air flow rate measurements and control, and b) other loss mechanisms not accounted for by vapor monitoring. With respect to the air injection rate measurement, the error associated with it is ± 0.5 L/min for air flow rates > 0.1 L/min.

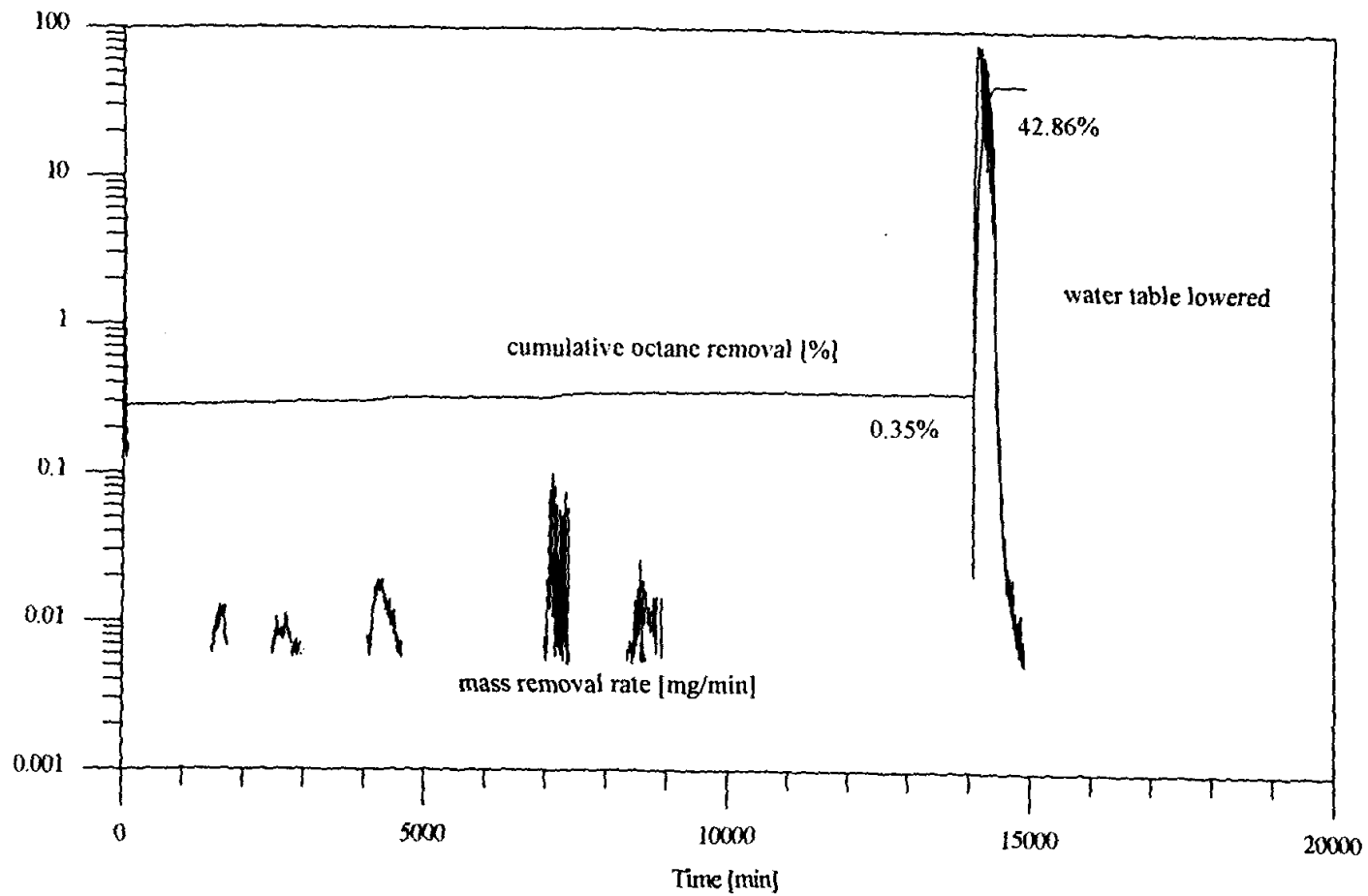

Figure 5.24: Mass removal rate and cumulative octane removal vs. time for $Q_{air} = 10$ L/min both steady pulsed injection and $M = 35.14$ g, final wet medium experiment. Draining of the physical model occurred at 14012 min.

With respect to other loss mechanisms we considered losses due to solubilization of hydrocarbons into the water and biological degradation. The former proved to be negligible considering the limited solubility and small volume of water used in these experiments (<1 % error for mass balances). Biodegradation is a possibility given the degradability of the compounds used. Unfortunately, none of the measurements made during these experiments provide direct measures of biodegradation. Based on results from field bioventing studies, possible biodegradation rates might be estimated to be on the order of 10 mg/d. Using that estimate one could argue that biodegradation losses would not be expected to be significant given the duration of these experiments.

To investigate the potential that biodegradation played a role in mass losses, Figure 5.24 was prepared. In this figure we plot the mass unaccounted for as a function of the duration of the experiment. The idea here is that biodegradation losses should increase in proportion to time. The reader can draw their own conclusions from the data, and decide whether or not this is a valid analysis. Using all of the data in a least-squares best-fit linear regression yields a loss rate constant of 1 mg/min, or 1.4 g/d, with $R^2 = 0.64$. This rate is about two orders of magnitude greater than degradation rate losses from field studies, and translates roughly to a loss of about 4% of the initial mass per day for the majority of experiments conducted during this study.

CHAPTER 6

CONCLUSIONS AND RECOMMENDATIONS

Conclusions

The following conclusions can be drawn from the results and discussions presented in Chapter 4 and Chapter 5:

- The maximum removal achieved by volatilization is affected by water saturation. In these experiments the maximum cumulative removal achieved is lower in wet media than in dry media. For dry media experiments, 84% removal of the initial injected mass was recovered for both octane and hexane. For wet media experiments the cumulative removal achieved varied from 50% to 85%.
- Vapor concentrations and the mass removal rates initially vary smoothly with time for both wet and dry media experiments. After some time, however, large fluctuations about the average are observed in wet media (for example, see Figure 5.18 & 5.19).
- Air flow rate affects the initial removal rate of hydrocarbons; with higher flow rates corresponding to higher initial mass removal rates. The asymptotic cumulative mass recovered, however, appeared to be relatively independent of the air flow rate.

- Relative to steady air flows, pulsing the air flow causes changes in the magnitude and frequency of effluent vapor concentration fluctuations. This appears to improve the cumulative removal of octane by volatilization; little effect was noted on the volatilization of hexane.
- Initial mass removal rates for hexane were greater than those for octane in both dry and wet media experiments. Thus the initial mass removal rates in wet media appear to be proportional to a compound's molecular weight and vapor pressure, as is expected from the conceptual model presented in Chapter 2.
- Contrary to the observation of Chao et al., ratios of Dimensionless Henry's Law Constants do not provide a qualitative assessment of removal efficiencies of the chemicals studied. The Henry's law constants ratio for octane/hexane is 2.1 (octane/hexane = 93/43), while the % removal ratio for octane/hexane at the end of 1 d for a steady air flow rate of 10 L/min is 0.52 (% removal of hexane/ % removal of octane = 41/79). For the pulsed air flow the ratio was 0.83 (71/86).
- The ratio of saturated vapor concentrations for octane/hexane is 0.12, which compares favorably with the ratio of experimental initial mass removal rates presented in Table 5.3. This suggests that the initial and most significant mass removal from source zones is proportional to the product of the molecular weight and vapor pressure of the compound being removed. This is consistent with our conceptual model which pictures the early stages of mass removal to occur from within the air flow field channels, such that the removal behaves much like volatilization during soil vapor extraction (dry media).
- Volatilization losses appear to be insignificant when the hydrocarbon source is located (approximately 60 cm) away from the air flow field. This implies that removal by volatilization may

be limited to the near field surrounding the zone of air flow, unless the contaminant solubility is very high.

- The conceptual model for removal by volatilization hypothesized earlier in this thesis (Figure 2.1) adequately explains many of the gross features of the experimental data. Initial mass removal is similar to that observed in dry media, while long-term mass removal rates appear to be diffusion-limited. Most of the mass removal occurs in the early stages of in situ air sparging, and the cumulative amount removed appears to be practically limited to the zone of air flow distribution. There appears to be a dependence of total cumulative removal on compound type, with increasing cumulative removal with increasing vapor pressure and solubility.
- The initial removal rates appear to be linearly proportional to air injection rate; however, the long-term cumulative removal appeared to be relatively insensitive to flow rate for the two flow rates studied.
- Pulsing the air flow rate improved the cumulative removal of hydrocarbons, for both chemicals studied.

Recommendations

While our goal has been only to look for qualitative trends in the dependence of air sparging on process conditions (flow rate, pulsing, etc.), it is important to consider several factors that limit the applicability of these results to actual field settings. First, the experiments were conducted with a homogeneous and coarse media. In nature, soil systems always have heterogeneities and a wide range of

particle sizes. Future investigations might account for soil heterogeneity, by conducting two dimensional source volatilization experiments in heterogeneous media simulated by mixing selected glass beads of various diameters, or by placing layers of differing materials.

Second, natural soil systems are three-dimensional, while the physical model used in these experiments constrains air flow to two dimensions. The results might therefore be affected by constraints of the system. Future experiments should be performed in a three-dimensional tank to evaluate the impact of dimensionality.

Third, a single compound was used, while at many hydrocarbon spill sites multiple compounds will be present. In these cases, one compound may affect the removal efficiencies of other compounds. Future experiments should be conducted with well-characterized mixtures in either a two or a three-dimensional tank.

Fourth, during the wet media experiments there was no imposed flow across the tank (except in the case when the source was located away from the air flow field) and both the compounds used for the studies were very insoluble in water. In actual aquifers, there is a natural groundwater flow. For hydrocarbons that dissolve appreciably in groundwater this movement could improve the performance of air sparging. Future experiments should be conducted with more soluble hydrocarbons and imposed water flows in either a two- or three-dimensional tank.

Fifth, it was observed that pulsing produced a better overall performance for both the chemicals in terms of cumulative removal. In all cases the same pulsing interval frequency was used, therefore future experiments could explore the effect of changing the pulsing intervals.

Finally, these experiments were conducted under conditions that did not favor biodegradation. Thus, the effect of aerobic degradation on the cumulative removal of hydrocarbons was not studied. Future experiments should allow for degradation to occur in order to determine the significance of biodegradation during source zone treatment experiments.

REFERENCES

- Baker, S. R., M. E. Hayes & S. H. Frisbie . "Evidence of preferential vapor flow during in situ air sparging". In situ aeration: Air sparging, Bioventing, and related remediation processes. R. L. Hinchee, R. N. Miller & P.C. Johnson. Battelle Press, 1995.
- Boersma, P., F. S Petersen, P. Newman, R. Huddleston (1993). "Use of groundwater sparging to effect hydrocarbon biodegradation". NWWA. 1993: 557 - 559.10.
- Boersma, P., K. R. Piontek & P. A. B. Newman. "The role of groundwater sparging in hydrocarbon remediation". Presented at API Pipeline Conference, Houston, TX, April 25 - 28, 1994.
- Boersma, P., K. R. Piontek & P. A. B. Newman. " Sparging effectiveness for groundwater restoration". In situ aeration: Air sparging, Bioventing, and related remediation processes. R. L. Hinchee, R. N. Miller & P.C. Johnson. Battelle Press, 1995.
- Brown, R. A. & R. Fraxedas (1991). "Air sparging - extending volatilization to contaminated aquifers". Presented at Symposium on Soil Venting. Robert S. Kerr Environmental Research Laboratory. Houston, TX, April 29 - May 1, 1991.
- Chao, K. P. & S.K. Ong. "Air sparging: effects of VOCs and soil properties on VOC volatilization". In situ aeration: Air sparging, Bioventing, and related remediation processes. R. L. Hinchee, R. N. Miller & P.C. Johnson. Battelle Press. 1995.
- Clayton, S. W., R. A. Brown & D. H. Bass. "Air sparging and bioremediation: the case for in-situ mixing". In situ aeration: Air sparging, Bioventing, and related remediation processes. R. L. Hinchee, R. N. Miller & P.C. Johnson. Battelle Press, 1995.
- Harkness, M. R., J. D. Ciampa & A. A. Bracco. "A laboratory assessment of air sparging performance on oil-contaminated soil. In situ aeration: Air sparging, Bioventing, and related remediation processes. R. L. Hinchee, R. N. Miller & P.C. Johnson. Battelle Press, 1995.
- Hinchee, R. E. "Air sparging state of the art". Air sparging for site remediation. Edited by R. E. Hinchee. Lewis publisher, 1994.
- Ji, Wei (1994). "Air sparging: experimental and theoretical analysis of flow and numerical modeling of flow and numerical modeling of mass transfer". Ph. D. dissertation. The university of Connecticut.
- Ji, Wei, Amine Dahmani, David P. Ahfeld, Jia Ding Lin, Edward Hill III (1993). "Laboratory study of air sparging: air flow visualization". GWMR. Fall 1993: 115 - 126.
- Johnson, P. C., R. L. Johnson, C. Neaville, E. E. Hansen, S. M. Sterns & Iras J. Dortch. "Do conventional monitoring practices indicate in situ air sparging performance?". In situ aeration: Air sparging, Bioventing, and related remediation processes. R. L. Hinchee, R. N. Miller & P.C. Johnson. Battelle Press, 1995.
- Johnson, R. L. "Enhancing biodegradation with in situ air sparging: A conceptual model". Air sparging for site remediation. Edited by R. E. Hinchee. Lewis publisher, 1994.
- Johnson, R. L., N. R. Thomson and P. C Johnson (1993). "Does sustained groundwater circulation occur during in-situ air sparging".
- Johnson, R. L., P.C. Johnson, D. B. McWhorter, R. E. Hinchee and I. Goodman (1993). "An overview of in situ air sparging". GWMR. Spring 1993, pp. 127 - 135.

- Kaback S. D., B. B. Looney, C. A. Eddy & T. C. Hazan (1991). "Innovative groundwater and soil remediation: in situ air stripping using horizontal wells". *Ground Water Management*, No. 5, 1991, pp. 47 - 58.
- Lesson, A., R. E. Hinchee, G. L. Hedington & C. M. Vogel. "Air channel distribution during air sparging: a field experiment". In *situ aeration: Air sparging, Bioventing, and related remediation processes*. R. L. Hinchee, R. N. Miller & P.C. Johnson. Battelle Press, 1995
- Loden, M. E. (1992). "A technology assessment of soil vapor extraction and air sparging". Research and Development. U.S. Environmental Protection Agency.
- Lundegard, P.D. "Air sparging: Much ado about nothing". In *situ aeration: Air sparging, Bioventing, and related remediation processes*. R. L. Hinchee, R. N. Miller & P.C. Johnson. Battelle Press, 1995.
- Marley, M.C. (1991). "Air sparging in conjunction with vapor extraction for source removal at VOC spill sites". Paper presented at the fifth national outdoor action conference at Las Vegas, Nevada. May 13 - 16, 1991.
- Marley, M. C., C. J. Bruell & H. H. Hopkins. "Air sparging technology: a practice update". In *situ aeration: Air sparging, Bioventing, and related remediation processes*. R. L. Hinchee, R. N. Miller & P.C. Johnson. Battelle Press, 1995.
- McAllister, P.M., C. Y. Chiang (1994). "A practical approach to evaluating natural attenuation of contaminants in ground water". *GWMR*. Spring 1994: 161 - 173.
- Mohr, H. D (1995). "Mass transfer concepts applied to in situ air sparging". Chevron research and technology company. Richmond, CA 94804.
- Payne, F. C., A. R. Blaske & G. A. VanHouten. "Contaminant removal rates in pulsed and steady-flow aquifer sparging". In *situ aeration: Air sparging, Bioventing, and related remediation processes*. R. L. Hinchee, R. N. Miller & P.C. Johnson. Battelle Press, 1995.
- Rutherford, K. W (1995). "Evaluation of mass transfer rates during a laboratory scale air sparging experiment". M. S. Thesis. Arizona State University.
- Symons, B.D., R. Linkenheil, D. Pritchard, C.A. Shanke & D. Seep. "In situ groundwater aeration of polycyclic aromatic hydrocarbons". In *situ aeration: Air sparging, Bioventing, and related remediation processes*. R. L. Hinchee, R. N. Miller & P.C. Johnson. Battelle Press, 1995.
- Verschuere Karel (1977). *Handbook of environmental data on organic chemicals*. Van Nostrand Reinhold Company.
- Wehrle, K. & J. Brauns. "Groundwater circulation due to air injection: general aspects and experimental results for layered subsoil". *Air sparging for site remediation*. Edited by R. E. Hinchee. Lewis publisher, 1994.

APPENDIX A
OXYGEN MASS TRANSFER STUDIES

INTRODUCTION

In addition to the experiments described in the main body of this thesis, other experiments not directly related to the objective of this study were conducted. These experiments focused on oxygen mass transfer during air sparging in a layered geologic system, and are an extension of the work of Rutherford (1995).

EXPERIMENTAL APPARATUS AND PROCEDURES

Physical Model

The two-dimensional aquifer physical model described in Chapter 3 was used for these studies. The physical model is 244 cm (8 ft) long, 122 cm (4 ft) in height and 5.08 cm (2 in) wide. Two lower permeability 0.11-mm diameter glass beads layers were created in the physical model while packing it with 1-mm diameter glass beads. The thickness of each 0.11-mm diameter glass bead layers was 2.5 cm (1 in). They were located at 30 cm and 60 cm respectively from the bottom of the physical model. Figure A1 shows the dimensions and relative locations of the low permeability layers.

The flow loop and the measuring and monitoring devices used for these experiments appear in Figure A2. Table A1 provides a summary of the measurement devices.

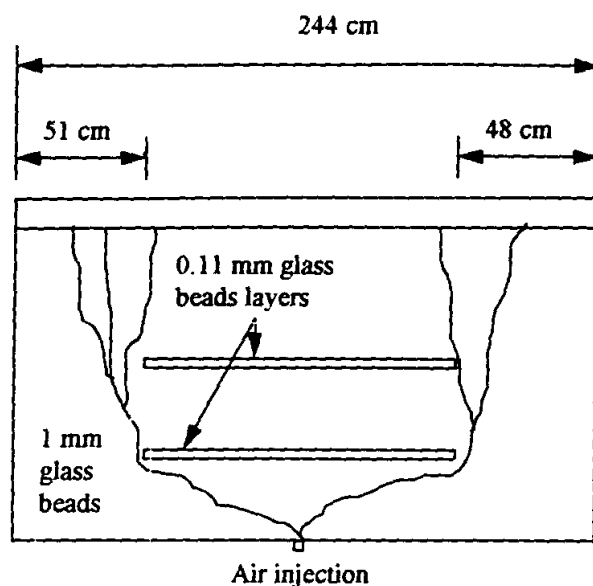

Figure A1: Layered setting for the physical model shown with typical air flow field.

Table A1. Summary of measurement devices and calibration data (Rutherford 1995).

Measurements	Devices	Scale/Precision
Liquid flow rate	Dwyer RMA Ratemaster	0 - 300 ± 2.5 mL/min water
Liquid flow rate	Dwyer RMA Ratemaster	0 - 300 ± 3.5 mL/min water
Air flow rate	Dwyer RMA Ratemaster	1 - 25 ± 1.9 L/min air
Air flow rate	Dwyer RMA Ratemaster	2 - 20 x 100 ± 4 mL/min air
Air flow rate	Dwyer RMA Ratemaster	2 - 50 ± 3 L/min air
Dissolved oxygen	Leeds and Northup model 7931-25/063341 and 7931-30/063316	0 - 20 ± 0.1 mg/L
Dissolved oxygen	Orion O ₂ selective electrode model 97-08-00	0 - 14 ± 0/05 mg/L
Air pressure	Dwyer magnehelic gauge	0 - 150 ± 3 in water column

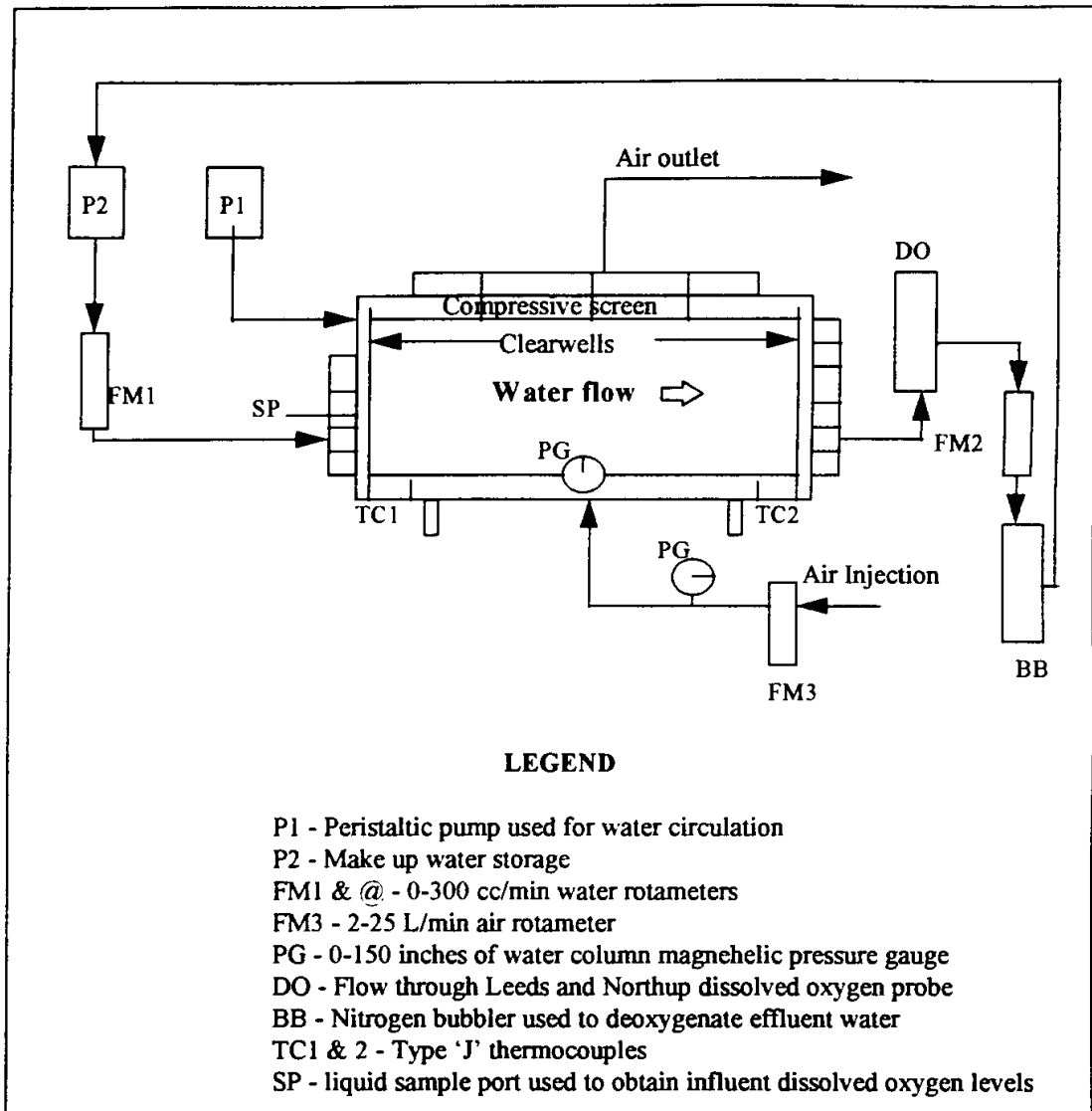

Figure A2. Experimental flow loop.

Experimental Protocol for Mass Transfer Studies

Constant water flow rate with variable air injection rate

More details concerning the experimental protocol and data reduction are found in Rutherford (1995). In some cases the oxygen mass transfer rates were calculated from the experimental data for different air injection rates, collected while keeping the water flow rate constant at 270 cm³/min in the physical model. Individual experiments were conducted with air injection rates ranging from 0.1 L/min to 20 L/min. Air injection was begun by turning on the in-house air system to a desired air flow rate. Inlet dissolved oxygen concentrations were measured periodically by taking 50 mL samples from the inlet stream sample port. An ORION O₂ selective electrode was used for the measurements. Continuous measurements of outlet oxygen concentrations were obtained by the in-line flow-through Leeds and Northup dissolved oxygen probe. When dissolved oxygen concentration fluctuations were less than ± 0.1 mg/L, it was assumed that the experiment had achieved steady state.

Constant air injection with no water circulation

In these experiments, the air injection rate was maintained at 7 L/min and there was no water circulation. Each experiment was run for a preselected time such as 1, 9, 24 and 72 h.

First, the physical model was filled with water from the bottom. Then the water was circulated in the tank while the nitrogen bubbler was functioning. Inlet and outlet dissolved oxygen (DO) were measured periodically. Water circulation was stopped when the inlet DO level dropped below 2.5 mg/L.

and the outlet DO was around ± 0.3 mg/L of the inlet DO. Initial DO of the tank water assumed to be equal to the value measured at the tank inlet prior to the turning off the flow. Next, air injection was begun at a constant rate of 7 L/min. After an hour air injection was turned off and the water inside the tank was immediately pumped out of the tank using the drain ports at the tank bottom. Once the tank was completely drained the volume-averaged DO and the total volume of water were measured. Similar procedures were followed for the 9, 24 and 72 h experiments.

MATERIALS

Properties of the glass beads are shown in Table 3.3. Rutherford (1995) determined the moisture retention and permeability of the 1 mm glass beads. The moisture retention curve and permeability of 0.11 mm glass beads were determined in this work..

The moisture retention curve was obtained by using a Soilmoisture #1400 Tempe Pressure Cell. The Tempe Pressure Cell essentially contains a porous plate and a brass cylinder. First, the porous plate is saturated with distilled water. The drain tube of the cell is then connected to a jar filled with water. The height of water in the jar is adjusted so that water level is just at the top of the porous plate. Next, the brass cylinder is placed above the porous plate. It is then filled with 0.11-mm diameter glass beads. The water level in the jar is raised to the top level of the brass cylinder in order to saturate the beads. The top part of the cell is attached and the wing nuts are tightened. Weights of both the empty cell and the cell with beads are registered. The cell is then connected to an in-house air supply line through a pressure regulator. Air pressure in the cell is raised to the desired level and measured on a Dwyer capsuhelic pressure gauge. Water dripping from the drain tube is collected and the cell is weighed again.

This procedure is followed for a number of incremental pressures increase. At the end of the experiment the beads are dried at 105°C for 24 h and are weighed again.

Moisture content is calculated using Equation A1. The results are shown in Table A2. Figure A3 shows a plot of moisture content vs. applied pressure.

Table A2. Moisture content calculations.

Mass of Tempe cell	395.3 g
Mass of Tempe cell with dry beads	500.9 g
Mass of Tempe cell with saturated beads	524.9 g
Mass of Tempe cell at the end of the test	504.4 g
Mass of beads at the end of the test	109.1 g
Mass of dry beads (after heating @ 105°C for 24 hours)	105.45 g

Pressure Applied	Mass of Cell Before Pressure Change	Mass of Cell After Pressure Change	Moisture Lost Due to Pressure Change	Moisture Lost Cumulative	Moisture Content
[in of H ₂ O]	[g]	[g]	[g]	[g]	[g-H ₂ O/g-beads]
2	524.9	524.9	0.0	0.0	0.23
5	524.9	524.9	0.0	0.0	0.23
10	524.9	524.2	0.7	0.7	0.22
12	524.2	524.1	0.1	0.8	0.22
16	524.1	524.0	0.1	0.9	0.22
20	524.0	524.0	0.0	0.9	0.22
26	524.0	524.0	0.0	0.9	0.22
30	524.0	523.7	0.3	1.2	0.22
40	523.7	519.7	4.0	5.2	0.18
44	519.7	515.6	4.1	9.3	0.14
50	515.6	507.9	7.7	17.0	0.07
56	507.9	506.1	1.8	18.8	0.05
62	506.1	504.6	1.5	20.3	0.04
67	504.6	504.6	0.0	20.3	0.04
78	504.6	504.6	0.0	20.3	0.04
90	504.6	504.6	0.0	20.3	0.04
120	504.6	504.4	0.2	20.5	0.04

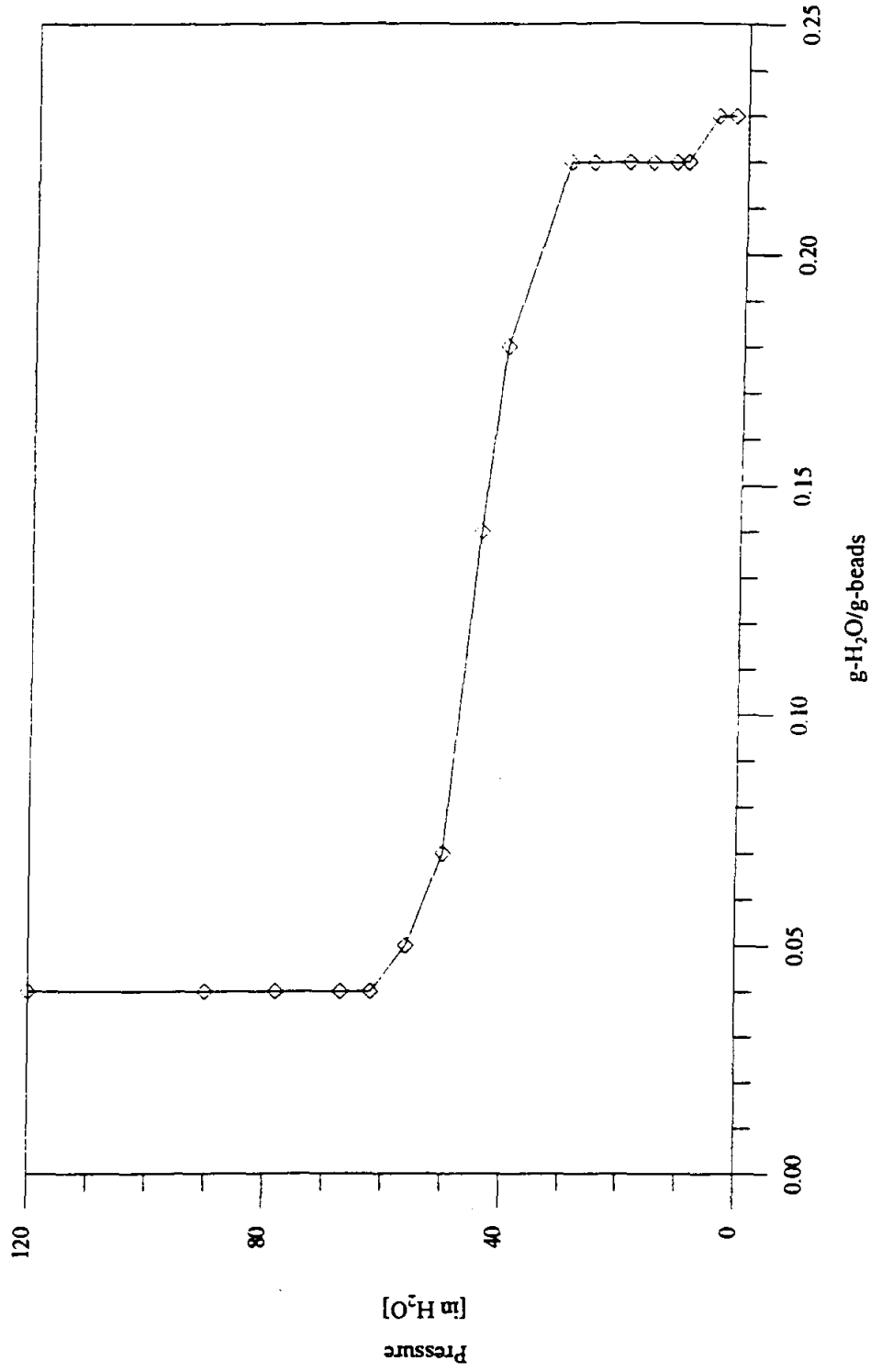

Figure A3: Moisture retention curve for 0.11 mm glass beads

$$\theta = (W_w/W_B) \quad (A1)$$

θ = moisture content (%) [g-H₂O/g-beads]

W_w = mass of residual water [g] [measured]

W_B = mass of dry beads [g] [measured]

During the water recirculation experiments, the average horizontal permeability to water for the 0.11-mm diameter glass beads was determined at each air flow rate. In these experiments the physical model is filled with water from the bottom. Next, a constant water flow rate of 270 cm³/min is established. After that, air injection is started by turning on the in-house air supply line. The head difference of water across the tank and the saturated soil column height at the tank outlet are recorded for each individual air flow rate. A Dwyer Capsuhelic gauge (0 - 2 in H₂O) was used to measure head differences. It was connected to the inlet and outlet clear wells at identical elevations. Both air and water flow rates were measured using Dwyer RMA Ratemaster flow meters of different capacities. Table A1 summarizes the measurement devices.

The following equation was used to calculate the average horizontal permeability to water flow:

$$v = (-kg\rho/\mu)(dh/dl) = Q/A \quad (A2)$$

v = Darcy velocity or specific discharge (length/time)

k = permeability (length²)

ρ = fluid density (mass/length³)

g = gravity constant (length/time²) [980 cm/s²]

μ = dynamic viscosity (mass/length-time)

dh = head difference across tank (in of water) [measured]

dl = length of porous media (length) [244 cm]

Q = flow rate of water (length³/time) [measured]

A = cross sectional area exposed to flow (length²) [measured]

Table A3 and Figure A4 present measured and calculated results for these experiments.

Table A3: Average permeability calculations.

Water flow rate	[Q]	270 cm ³ /min
Length of the porous media	[l]	244 cm
Thickness of the porous media	[b]	5.08 cm
Water density	[ρ]	1 g/cm ³
Dynamic viscosity of water	[μ]	0.00808 g/cm-s

Air Injection Rate	Head Difference	Saturated Column Height	Air injection Pressure	Permeability	Permeability
[L/min]	[in H ₂ O]	[in]	[in H ₂ O]	[ft ²]	[cm ²]
0.1	0.6	41.38	51.3	2.05 E-08	1.88 E-05
0.6	0.6	41.38	51.3	2.05 E-08	1.88 E-05
2	0.6	41.63	51.3	2.03 E-08	1.87 E-05
7	0.6	41.81	77.6	2.03 E-08	1.86 E-05
12	0.6	42.25	122	2.01 E-08	1.84 E-05
15	0.6	42.81	171.9	1.98 E-08	1.82 E-05
17	0.6	42.88	207.9	1.98 E-08	1.82 E-05
20	0.6	43.50	232.3	1.95 E-08	1.79 E-05

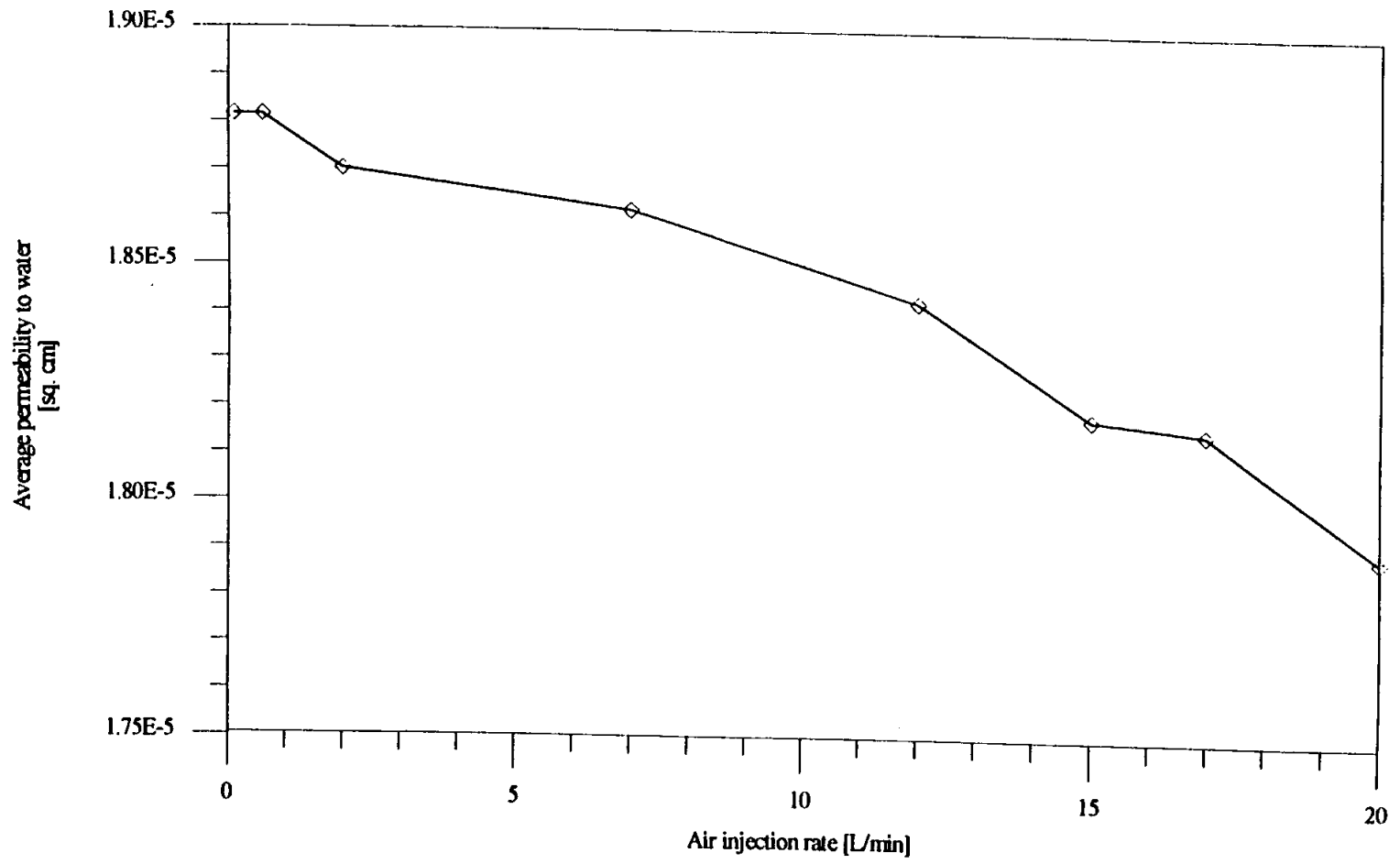

Figure A4: Average permeability vs. air injection rate for a layered system.

RESULTS

Constant water flow rate with variable air injection rate

For the experiments involving water recirculation the oxygen mass transfer rates were calculated using the following equation:

$$M = (C_{\text{outlet}} - C_{\text{inlet}}) * Q_w \quad (\text{A3})$$

M = Mass transfer rate of oxygen (mass/time) [calculated]

C_{inlet} = dissolved oxygen concentration at tank inlet (mass/length³) [measured]

C_{outlet} = dissolved oxygen concentration at tank outlet (mass/length³) [measured]

Q_w = water flow rate (length³/time) [measured]

In these calculations a time-averaged value was used for the inlet dissolved oxygen concentration. That value was obtained by averaging the eight (8) h of inlet dissolved oxygen readings prior to the end of the test. For the outlet dissolved oxygen value the final measured value was used.

Table A4 shows the calculated oxygen mass transfer rates; oxygen mass transfer rate are plotted vs. injection pressure in Figure A5.

Table A4: Oxygen mass transfer rate calculations.

Air Injection Rate	Steady State Outlet DO Concentration	Steady State Outlet DO Concentration	O ₂ Mass Transfer Rate	Exp. Duration	Air Injection Pressure
[L/min]	[mg/L]	[mg/L]	[mg/day]	[min]	[in H ₂ O]
0.1	1.40	5.22	1485	1740	51.3
0.6	1.46	6.50	1959	2220	51.3
2	1.48	7.16	2208	2040	51.3
7	1.46	7.60	2387	1338	77.6
12	1.45	7.75	2449	2160	122
15	1.37	7.75	2480	1260	171.9
17	1.26	7.75	2523	1500	207.9
20	0.73	7.65	2690	720	232.3

Constant air injection with no water circulation

For those experiments in which there was not induced groundwater flow across the physical model the mass transfer rate of oxygen was calculated using Equation A4:

$$M = (C_{\text{final}} - C_{\text{initial}}) * (V_{\text{water}} / \Delta T) \quad (\text{A4})$$

M = mass transfer rate of oxygen (mass/time) [calculated]

C_{final} = Final averaged DO concentration in the tank (mass/length)

C_{initial} = Initial averaged DO concentration in the tank (mass/length)

ΔT = length of experiment (time) [measured]

V_{water} = total volume of water in the tank (length) [measured]

Figure A6 presents a plot of oxygen mass transfer rate (mg/d) for each experiment vs. time.

Table A5 incorporates the measured and calculated values for these experiments.

Table A5: Time-averaged oxygen mass transfer rates.

Air injection rate : 7 L/min

Date	Duration	DO Conc. Initial	DO Conc. Final	Vol. of Water	Time Avg. Mass Trans.
	[d]	[mg/L]	[mg/L]	[L]	[mg/d]
3/20/96	0.042	1.25	1.42	49	199
3/25/96	0.375	1.43	2.13	50.5	94
4/3/96	1	1.35	2.7	44	59
3/28/96	3	1.93	4.021	47	33

DISCUSSION

From Figure A5 it can be seen that the oxygen mass transfer rates increase with increasing air injection rate; however, the slope of this curve is not as sharp once the air injection rate exceeds 2 L/min. Beyond the 2 L/min air injection rate, the curve approaches an asymptote. Figure A4 shows that permeability to liquid decreases with increasing air injection rate. Both of these phenomena were also observed in the case of air injection into a homogeneous medium (Rutherford 1995), although the permeability reduction at a given air flow rate is less in the model layered system litholog.

Figure A6 presents results of the constant air injection with no water circulation experiments. The time-averaged mass transfer rate decreases as the averaging time (experimental duration) increases. Rutherford (1995) showed that below a specific discharge of 80 cm/day (2.5 ft/day) mass transfer during

air sparging is dominated by diffusion. Results obtained in this experiment for layered systems also exhibit behavior characteristic of a diffusion dominated system.

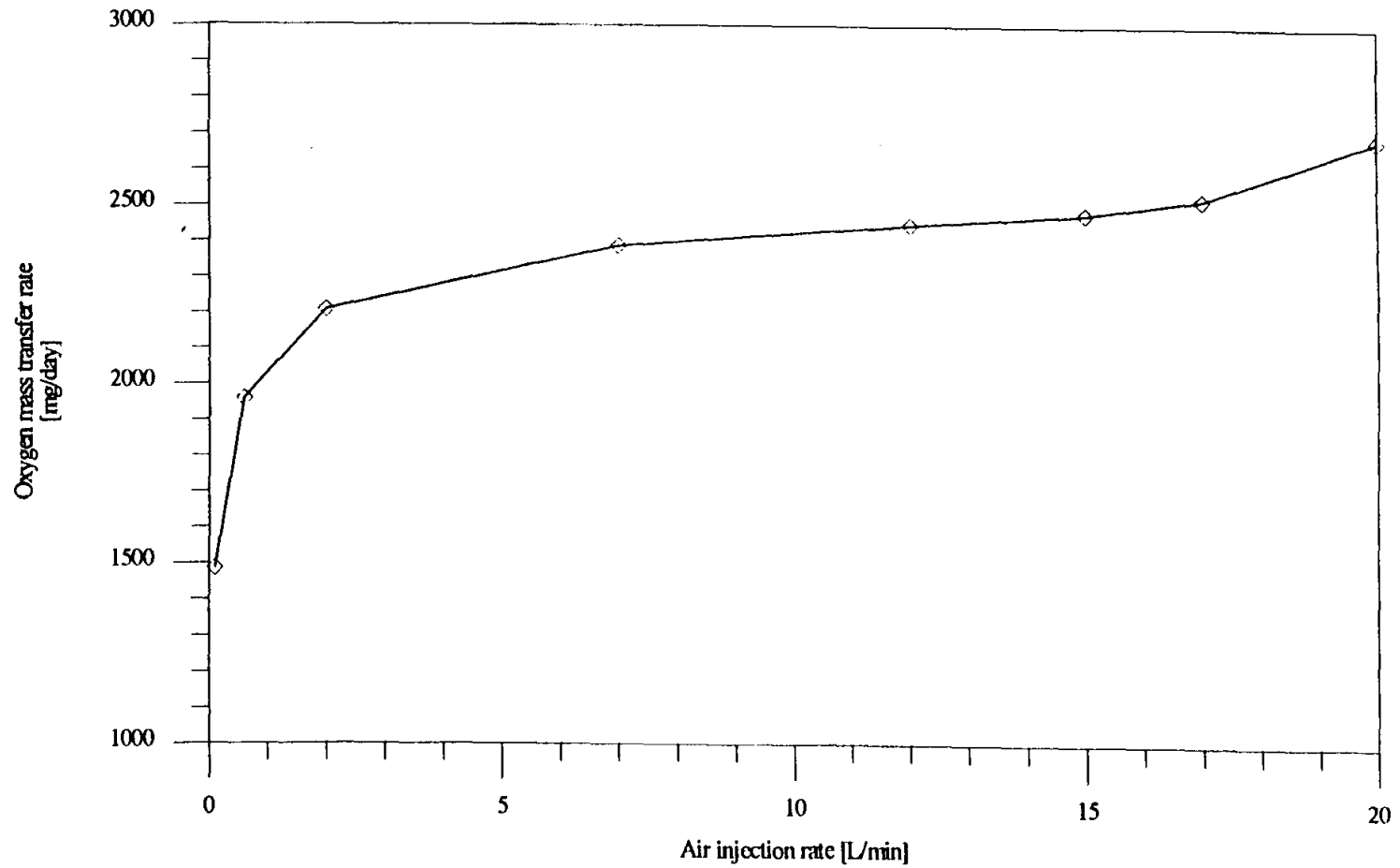

Figure A5: Oxygen Mass Transfer Rate vs. Air Injection Rate for constant water flowrate (270 cm³/min) and variable air injection for a layered system.

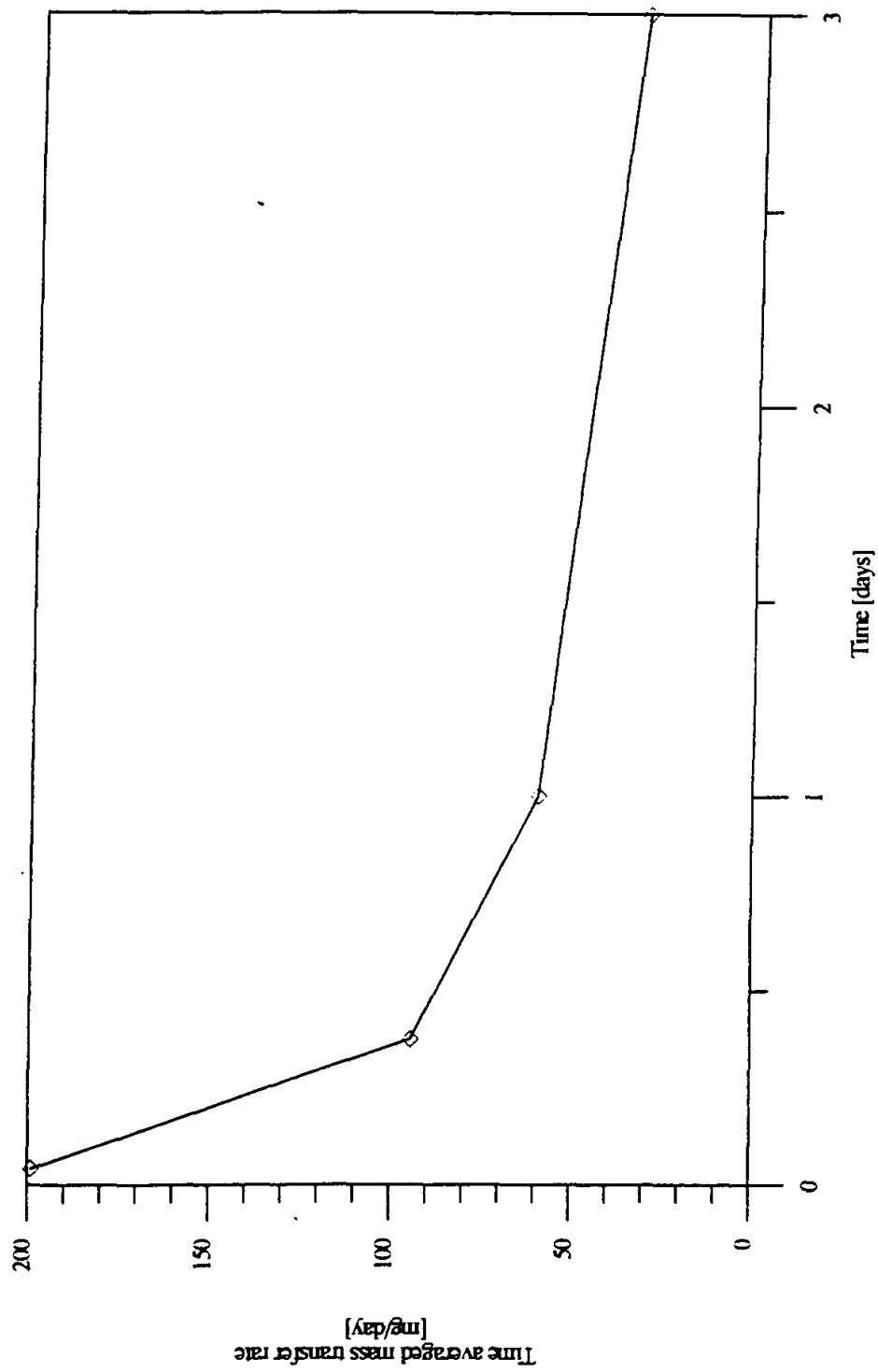
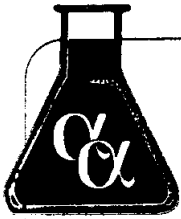

Figure A6: Time averaged oxygen mass transfer rate vs. time for constant air injection (7 L/min) and no water circulation in a layered system.

APPENDIX B
LABORATORY ANALYTICAL REPORTS



Alpha Analytical, Inc.

255 Glendale Avenue, Suite 21
Sparks, Nevada 89431
(702) 355-1044
FAX: 702-355-0406
1-800-283-1183

e-mail: alpha@powernet.net
http://www.powernet.net/~alpha

2505 Chandler Avenue, Suite 1
Las Vegas, Nevada 89120
(702) 498-3312
FAX: 702-736-7523
1-800-283-1183

Continued:

Client ID/ Lab ID	Parameter	Concentration	Detection Limit
PH2-MP6-15 /BMI071096-22	TPH (Diesel)	ND	1.0 mg/Kg
	TPH (Motor Oil)	ND	10 mg/Kg
	Benzene	ND	5.0 ug/Kg
	Toluene	ND	5.0 ug/Kg
	Ethylbenzene	ND	5.0 ug/Kg
	Total Xylenes	ND	5.0 ug/Kg
PH2-MP6-17 /BMI071096-23	TPH (Diesel)	ND	1.0 mg/Kg
	TPH (Motor Oil)	ND	10 mg/Kg
	Benzene	ND	5.0 ug/Kg
	Toluene	42	5.0 ug/Kg
	Ethylbenzene	ND	5.0 ug/Kg
	Total Xylenes	ND	5.0 ug/Kg
PH2-MP6-19 /BMI071096-24	TPH (Diesel)	ND	1.0 mg/Kg
	TPH (Motor Oil)	ND	10 mg/Kg
	Benzene	ND	5.0 ug/Kg
	Toluene	ND	5.0 ug/Kg
	Ethylbenzene	ND	5.0 ug/Kg
	Total Xylenes	ND	5.0 ug/Kg

ND - Not Detected

Approved By:

Roger L. Scholl
Roger L. Scholl, Ph.D.
Laboratory Director

Date:

7/23/96

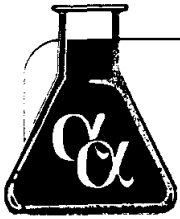

Alpha Analytical, Inc.

255 Glendale Avenue, Suite 21
Sparks, Nevada 89431
702-355-1044
FAX: 702-355-0406
1-800-283-1183

e-mail: alpha@power.net
http://www.power.net/~alpha

2505 Chandler Avenue, Suite 1
Las Vegas, Nevada 89120
702-498-3312
FAX: 702-736-7523
1-800-283-1183

continued:

MP1 Black /BMI091096-05	TPH (Purgeable)	32	13	mg/L
	Benzene	5100	50	ug/L
	Toluene	13000	50	ug/L
	Ethylbenzene	1400	50	ug/L
	Total Xylenes	7800	50	ug/L
MP10 Yellow /BMI091096-06	TPH (Purgeable)	0.89	0.050	mg/L
	Benzene	ND	0.5	ug/L
	Toluene	ND	0.5	ug/L
	Ethylbenzene	ND	0.5	ug/L
	Total Xylenes	ND	0.5	ug/L
MP10 BlackI /BMI091096-07	TPH (Purgeable)	ND	0.050	mg/L
	Benzene	0.56	0.5	ug/L
	Toluene	0.94	0.5	ug/L
	Ethylbenzene	0.68	0.5	ug/L
	Total Xylenes	0.75	0.5	ug/L
MP10 BlackII /BMI091096-08	TPH (Purgeable)	9.6	2.5	mg/L
	Benzene	1500	10	ug/L
	Toluene	27	10	ug/L
	Ethylbenzene	1800	10	ug/L
	Total Xylenes	2000	10	ug/L

ND - Not Detected

Approved by: Roger L. Scholl Date: 9/24/96
Roger W. Scholl, Ph.D.
Laboratory Director

Billing Information:

Name _____
 Address _____
 City, State, Zip _____
 Phone Number _____ Fax _____



Alpha Analytical, Inc.
 255 Glendale Avenue, Suite 21
 Sparks, Nevada 89431
 Phone (702) 355-1044
 Fax (702) 355-0406

Page # 1 of 1

Analyses Required

Client Name		P.O. #		Job #		Analyses Required														
Battello		121321		PORT HUENEME		TPHG BTX														
Address		PWS #		DWR#																
City, State, Zip		Phone #		Fax #																
Time Sampled	Date Sampled	Matrix* See Key Below	Office Use Only	Lab ID Number	Sample Description	Report Attention	Total and type of containers** See below													
	9/8	A		BMT09109601	mp7 BLUE		1 ✓	X												
				02	mp7 YELLOW		1 ✓	X	X											
				03	mp1 BLUE		1 ✓	X	X											
				04	mp1 YELLOW		1 ✓	X	X											
				05	mp1 BLACK		1 ✓	X	X											
				06	mp10 YELLOW		1 ✓	X	X											
				07	mp10 BLACK I		1 ✓	X	X											
	9/8	A		08	mp10 BLACK II		1 ✓	X	X											

REMARKS:

mp7 BLACK II WAS RECEIVED BROKEN

Signature	Print Name	Company	Date	Time
Relinquished by				
Received by <i>[Signature]</i>	TAMMY BRUCE	Alpha Analytical	9/10/96	1105
Relinquished by				
Received by				
Relinquished by				
Received by				

NOTE: Samples are discarded 60 days after results are reported unless other arrangements are made. Hazardous samples will be returned to client or disposed of at client expense.

Proj. No. 10# 121321		Project Title Port Hueneme			SAMPLE TYPE (✓)													
SAMPLERS: (Signature) <i>Paul Johnson</i>		<div style="display: flex; justify-content: space-between;"> BTEX MPH - Petroleum </div>										Container No.	Number of Containers					
DATE	TIME	SAMPLE I.D.																Remarks
9/8/96		MP7 - Black II																
		MP7 - Blue																
		MP7 - Yellow																
		MP1 - Blue																
		MP1 - Yellow																
		MP1 - Black II																
		MP10 - Yellow																
		MP10 - Black I																
		MP10 - Black II																
Relinquished by: (Signature) <i>Catherine Joyl</i>		Date/Time 9 Sept 96 1200		Received by: (Signature) <i>[Signature]</i>			Relinquished by: (Signature)			Date/Time		Received by: (Signature)						
Relinquished by: (Signature)		Date/Time		Received by: (Signature)			Relinquished by: (Signature)			Date/Time		Received by: (Signature)						
Relinquished by: (Signature)		Date/Time		Received for Laboratory by: (Signature)			Date/Time		Remarks									

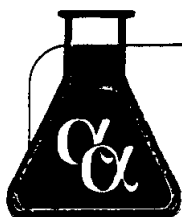

Alpha Analytical, Inc.

255 Glendale Avenue, Suite 21
Sparks, Nevada 89431
(702) 355-1044
FAX: 702-355-0406
1-800-283-1183

e-mail: alpha@powernet.net
<http://www.powernet.net/~alpha>

2505 Chandler Avenue, Suite 1
Las Vegas, Nevada 89120
(702) 498-3312
FAX: 702-736-7528
1-800-283-1183

SOIL VOLATILE MATRIX SPIKE/MATRIX SPIKE DUPLICATE RECOVERY

EPA Method 624/8240

Lab Name: Alpha Analytical, Inc.

AAI Lab ID: BMI062896-09

Date Analyzed: 7/4/96

Compound	Spike Added (ug/Kg)	Sample Concentration (ug/Kg)	MS Concentration (ug/Kg)	MS Percent Recovery #	QC Limits Recovery
Benzene	200	378	612	117	76-127
Toluene	200	4	226	111	76-125

Compound	Spike Added (ug/Kg)	MSD Concentration (ug/Kg)	MSD Percent Recovery #	QC Limit Recovery	Percent RPD #
Benzene	200	586	104	76-127	12
Toluene	200	212	104	76-125	7

Billing information.

Name _____
 Address _____
 City, State, Zip _____
 Phone Number _____ Fax _____



Alpha Analytical, inc.
 255 Glendale Avenue, Suite 21
 Sparks, Nevada 89431
 Phone (702) 355-1044
 Fax (702) 355-0406

Page # 1 of 1

Analyses Required

Client Name <i>Dittell</i>	P.O. # <i>602727-01</i>
Address	DWR # <i>Fort Humboldt</i>
City, State, Zip	Phone # Fax #

Time Sampled	Date Sampled	Matrix* See Key Below	Office Use Only	Sampled by <i>Client</i>	Report Attention	Total and type of containers ** See below	Analyses Required													
			Lab ID Number	Sample Description																
	<i>6/27</i>	<i>SO</i>	<i>LM-062876-03</i>	<i>PHI-MPI0-4</i>	<i>1 S</i>	<i>✓</i>	<i>✓</i>													
			<i>04</i>	<i>"</i>	<i>"</i>	<i>5</i>	<i>1 S</i>	<i>x</i>	<i>x</i>											
			<i>05</i>	<i>"</i>	<i>"</i>	<i>7</i>	<i>1 S</i>	<i>x</i>	<i>x</i>											
			<i>06</i>	<i>"</i>	<i>"</i>	<i>8</i>	<i>1 S</i>	<i>x</i>	<i>x</i>											
			<i>07</i>	<i>"</i>	<i>"</i>	<i>9</i>	<i>1 S</i>	<i>x</i>	<i>x</i>											
			<i>08</i>	<i>"</i>	<i>"</i>	<i>10</i>	<i>1 S</i>	<i>x</i>	<i>x</i>											
			<i>09</i>	<i>"</i>	<i>"</i>	<i>11</i>	<i>1 S</i>	<i>x</i>	<i>x</i>											
			<i>10</i>	<i>"</i>	<i>"</i>	<i>12</i>	<i>1 S</i>	<i>x</i>	<i>x</i>											
			<i>11</i>	<i>"</i>	<i>"</i>	<i>13</i>	<i>1 S</i>	<i>x</i>	<i>x</i>											
			<i>12</i>	<i>"</i>	<i>"</i>	<i>15</i>	<i>1 S</i>	<i>x</i>	<i>x</i>											
			<i>13</i>	<i>"</i>	<i>"</i>	<i>19</i>	<i>1 S</i>	<i>x</i>	<i>x</i>											
			<i>14</i>	<i>"</i>	<i>"</i>	<i>17</i>	<i>1 S</i>	<i>x</i>	<i>x</i>											

REMARKS:

Ca. site

Signature	Print Name	Company	Date	Time
<i>[Signature]</i>	<i>Linda Byrdick</i>	<i>AAI</i>	<i>6/28/76</i>	<i>1030</i>
Relinquished by				
Received by				
Relinquished by				
Received by				
Relinquished by				
Received by				

NOTE: Samples are discarded 60 days after results are reported unless other arrangements are made. Hazardous samples will be returned to client or disposed of at client expense.
 *Key: AQ - Aqueous SO - Soil WA - Waste OT - Other ** L-Liter V-Voa S-Soil Jar O-Orbo T-Tedlar B-Brass P-Plastic OT-Other

06-27-1996 11:51AM

1 614 424 3667

TOTAL P.002 P.02



Battelle

Columbus Laboratories

CHAIN OF CUSTODY RECORD

Form No. _____

Proj. No. G002727-01	Project Title Port Hueneme - site 1
-------------------------	--

SAMPLERS: (Signature)
J. Kramer, C. Perry, E. Black

DATE	TIME	SAMPLE I.D.	SAMPLE TYPE (✓)										Container No.	Number of Containers	Remarks			
✓ 6/27/96	15:20	PH1-MP10-4	✓	✓														
✓ 6/27/96	15:20	PH1-MP10-5	✓	✓													1 SS	sleeve
✓ 6/27/96	15:20	PH1-MP10-7	✓	✓													"	"
✓ 6/27/96	15:20	PH1-MP10-8	✓	✓													"	"
✓ 6/27/96	15:20	PH1-MP10-9	✓	✓													"	"
✓ 6/27/96	15:20	PH1-MP10-10	✓	✓													"	"
✓ 6/27/96	15:50	PH1-MP10-11	✓	✓													"	"
✓ "	"	PH1-MP10-12	✓	✓													"	"
✓ "	"	PH1-MP10-13	✓	✓													"	"
✓ "	"	PH1-MP10-15	✓	✓													"	"
✓ "	"	PH1-MP10-19	✓	✓													"	"
✓ "	"	PH1-MP10-17	✓	✓													"	"
PH1-MP10																		

TPH-8015
 BTEX-82740

Relinquished by: (Signature) <i>J. Kramer</i>	Date/Time 6/27/96 16:45	Received by: (Signature)	Relinquished by: (Signature)	Date/Time	Received by: (Signature)
Relinquished by: (Signature)	Date/Time	Received by: (Signature)	Relinquished by: (Signature)	Date/Time	Received by: (Signature)
Relinquished by: (Signature)	Date/Time	Received for Laboratory by: (Signature) <i>[Signature]</i>	Date/Time 6/28/96 1030	Remarks	

Billing information:

Name _____
 Address _____
 City, State, Zip _____
 Phone Number _____ Fax _____



Alpha Analytical, Inc.
 255 Glendale Avenue, Suite 21
 Sparks, Nevada 89431
 Phone (702) 355-1044
 Fax (702) 355-0406

Page # 1 of 4

Analyses Required

Client Name		P.O. #		Job #		Analyses Required												
Battelle				6002727-01														
Address		PWS #		DWR #														
City, State, Zip		Phone #		Fax #														
Time Sampled	Date Sampled	Matrix* See Key Below	Office Use Only	Sampled by	Report Attention	Total and type of containers** See below												
			Lab ID Number	Sample Description														
	6-29	SO	BMI 070296-23		PH1-MP11-8'	1B	x	✓										
					PH1-MP11-19'	1B	x	✓										
					PH1-MP11-7'	1B	x	✓										
					PH1-MP11-9'	1B	x	✓										
					PH1-MP11-15'	1B	x	✓										
					PH1-MP11-4'	1B	x	✓										
					PH1-MP11-13'	1B	x	✓										
					PH1-MP11-17'	1B	x	✓										
					PH1-MP11-11'	1B	x	✓										
					PH1-MP11-12'	1B	x	✓										
					PH1-MP11-5'	1B	x	✓										
					PH1-MP11-10'	1B	x	✓										

1 PH-805
 07EX-8240

REMARKS:

CA site

Signature	Print Name	Company	Date	Time
Relinquished by				
Received by <i>Katherine Z Souza</i>	<i>Katherine Z Souza</i>	<i>AAA</i>	<i>7-2-96</i>	<i>1030am</i>
Relinquished by				
Received by				
Relinquished by				
Received by				

NOTE: Samples are discarded 60 days after results are reported unless other arrangements are made. Hazardous samples will be returned to client or disposed of at client expense.

*Key: AQ - Aqueous SO - Soil WA - Waste OT - Other **: L-Liter V-Voa S-Soil Jar O-Orho T-Tedlar B-Brass P-Plastic OT-Other

Billing Information:

Name _____
 Address _____
 City, State, Zip _____
 Phone Number _____ Fax _____



Alpha Analytical, Inc.
 255 Glendale Avenue, Suite 21
 Sparks, Nevada 89431
 Phone (702) 355-1044
 Fax (702) 355-0406

Analyses Required

Client Name		P.O. #		Job #																	
Ba felle				6002727-D																	
Address		PWS #		DWR #																	
City, State, Zip		Phone #		Fax #																	
Time Sampled	Date Sampled	Matrix* See Key Below	Office Use Only	Sampled by	Report Attention	Total and type of containers ** See below															
			Lab ID Number	Sample Description																	
	6/29	SO	Bm1070296-35	PH1-MPI-4'		1B	X	X													
				-36 PH1-MPI-5'		1B	X	X													
				-37 PH1-MPI-7'		1B	X	X													
				-38 PH1-MPI-7' DUP		1B	X	X													
				-39 PH1-MPI-9'		1B	X	X													
				-40 PH1-MPI-10'		1B	X	X													
				-41 PH1-MPI-11'		1B	X	X													
				-42 PH1-MPI-12'		1B	X	X													
				-43 PH1-MPI-13'		1B	X	X													
				-44 PH1-MPI-15'		1B	X	X													
				-45 PH1-MPI-17'		1B	X	X													
				-46 PH1-MPI-19'		1B	X	X													

TPH-8/DIS
BTEX ~~8/DIS~~

REMARKS:

CA SITE

Signature	Print Name	Company	Date	Time
Relinquished by				
Received by <i>M. Martinez Souza</i>	MARTINEZ SOUZA	AAI	7-2-96	10:30 AM
Relinquished by				
Received by				
Relinquished by				
Received by				

NOTE: Samples are discarded 60 days after results are reported unless other arrangements are made. Hazardous samples will be returned to client or disposed of at client expense.

Shipping Information

Name _____
 Address _____
 City, State, Zip _____
 Phone Number _____ Fax _____



Alpha Analytical, Inc.
 255 Glendale Avenue, Suite 21
 Sparks, Nevada 89431
 Phone (702) 355-1044
 Fax (702) 355-0406

Page # 3 of 4

Analyses Required

Client Name		P.O. #		Job #		Analyses Required															
Battelle				4002727-01		TPH-8015 BTEX															
Address		PWS #		DWR #																	
City, State, Zip		Phone #		Fax #																	
Time Sampled	Date Sampled	Matrix* See Key Below	Office Use Only Lab ID Number	Sampled by	Report Attention	Total and type of containers ** See below															
	6/29	SO	BMI 070290-47			1B	x	x													
			-118			1B	x	x													
			-119			1B	x	x													
			-50			1B	x	x													
			-51			1B	x	x													
			-52			1B	x	x													
			-53			1B	x	x													
			-54			1B	x	x													
			-55			1B	x	x													
			-56			1B	x	x													
			-57			1B	x	x													
	6/30		-58			1B	x	x													

REMARKS: NT1

CA SITE

Signature	Print Name	Company	Date	Time
Relinquished by				
Received by <u>M. Souza</u>	<u>Matherine Souza</u>	<u>AA1</u>	<u>7-2-96</u>	<u>1030 AM</u>
Relinquished by				
Received by				
Relinquished by				
Received by				

NOTE: Samples are discarded 60 days after results are reported unless other arrangements are made. Hazardous samples will be returned to client or disposed of at client expense.
 *Key: AQ - Aqueous SO - Soil WA - Waste OT - Other ** L-Liter V-Voa S-Soil Jar O-Orbo T-Tedlar B-Brass P-Plastic OT-Other

Billing Information:

Name _____
 Address _____
 City, State, Zip _____
 Phone Number _____ Fax _____



Alpha Analytical, Inc.
 255 Glendale Avenue, Suite 21
 Sparks, Nevada 89431
 Phone (702) 355-1044
 Fax (702) 355-0406

Analyses Required

Client Name		P.O. #		Job #																
Buttelle				6002727-01																
Address		PWS #		DWR #																
City, State, Zip		Phone #		Fax #																
Time Sampled	Date Sampled	Matrix* See Key Below	Office Use Only	Sampled by	Report Attention	Total and type of containers ** See below														
Lab ID Number	Sample Description																			
6/30	50	PHI-NTI-10'		Bm1 070296-59	1B	X X														
/	/	PHI-NTI-11'		-60	1B	X X														
/	/	PHI-NTI-12'		-61	1B	X X														
/	/	PHI-NTI-13'		-62	1B	X X														
/	/	PHI-NTI-15'		-63	1B	X X														

TPH-5015
BTEX

REMARKS:

CAF SITE

Signature	Print Name	Company	Date	Time
Relinquished by				
Received by <u>Matthew 2 Saiz</u>	<u>Katherine 2 Souza</u>	<u>AAI</u>	<u>7-7-96</u>	<u>1630PM</u>
Relinquished by				
Received by				
Relinquished by				
Received by				

NOTE: Samples are discarded 60 days after results are reported unless other arrangements are made. Hazardous samples will be returned to client or disposed of at client expense.



Battelle

Columbus Laboratories

CHAIN OF CUSTODY RECORD

Form No. _____

Proj. No.		Project Title		SAMPLE TYPE (✓)												Container No.	Number of Containers	Remarks		
DATE		TIME		SAMPLE I.D.		[Grid for Sample Type]														
C002727-01		Port Itueneme - site 1				[Hatched Grid]														
SAMPLERS: (Signature)				J. Kramer, C. Perry, E. Black																
✓	6/28/96	1415	PHI-MP12-7	✓	✓														155 sleeve	
✓	"	"	PHI-MP12-10'	✓	✓														"	
✓	"	"	PHI-MP12-11'	✓	✓														"	
✓	"	"	PHI-MP12-17	✓	✓														"	
✓	"	"	PHI-MP12-15	✓	✓														"	

Relinquished by: (Signature)	Date/Time	Received by: (Signature)	Relinquished by: (Signature)	Date/Time	Received by: (Signature)
J. Kramer					
Relinquished by: (Signature)	Date/Time	Received by: (Signature)	Relinquished by: (Signature)	Date/Time	Received by: (Signature)
Relinquished by: (Signature)	Date/Time	Received for Laboratory by: (Signature)	Date/Time	Remarks	
		Matthew Saey	7-2-96 10:30AM		

27



Battelle

Columbus Laboratories

CHAIN OF CUSTODY RECORD

Form No. _____

Proj. No.		Project Title		SAMPLE TYPE (✓)										Container No.	Number of Containers	Remarks	
DATE		TIME	SAMPLE I.D.	TPH-8015	BTEX-8210												
G002727-01		Port Hueneeme - Site 1															
SAMPLERS: (Signature) J. Kramer, C. Perry, E. Black																	
✓	6/28/96	10:30	PHI-MP4-4	✓	✓												1 SS sleeve
✓	6/28/96	10:30	PHI-MP4-5	✓	✓												" "
	"	"	PHI-MP4-7	✓	✓												" "
✓	"	"	PHI-MP4-6	✓	✓												" "
✓	"	"	PHI-MP4-9	✓	✓												" "
✓	"	"	PHI-MP4-10	✓	✓												" "
✓	"	"	PHI-MP4-11	✓	✓												" "
✓	"	"	PHI-MP4-12	✓	✓												" "
✓	"	"	PHI-MP4-13	✓	✓												" "
✓	"	"	PHI-MP4-17	✓	✓												" "
✓	"	"	PHI-MP4-19	✓	✓												" "
✓	6/28/96	1415	PHI-MP12-8	✓	✓												" "
✓	"	"	PHI-MP12-9	✓	✓												" "
✓	"	"	PHI-MP12-13	✓	✓												" "
✓	"	"	PHI-MP12-19	✓	✓												" "
✓	"	"	PHI-MP12-4	✓	✓												" "
✓	"	"	PHI-MP12-12	✓	✓												" "

Relinquished by: (Signature) J. Kramer	Date/Time	Received by: (Signature) Matthew Saly	Relinquished by: (Signature)	Date/Time	Received by: (Signature)
Relinquished by: (Signature)	Date/Time	Received by: (Signature)	Relinquished by: (Signature)	Date/Time	Received by: (Signature)
Relinquished by: (Signature)	Date/Time	Received for Laboratory by: (Signature) Matthew Saly	Date/Time 7-2-96	Remarks 7030	

Labeling information:

Name _____
 Address _____
 City, State, Zip _____
 Phone Number _____ Fax _____



Alpha Analytical, inc.
 255 Glendale Avenue, Suite 21
 Sparks, Nevada 89431
 Phone (702) 355-1044
 Fax (702) 355-0406

Analyses Required

Client Name		P.O. #		Job #																		
Battelle				6002727-01																		
Address		PWS #		DWR #																		
City, State, Zip		Phone #		Fax #																		
Time Sampled	Date Sampled	Matrix* See Key Below	Office Use Only	Sampled by	Report Attention	Total and type of containers ** See below																
			Lab ID Number	Sample Description																		
	6-28	SO	BMI 070296-13	PH1-MP12-9		1B	✓	✓														
			-14	PH1-MP12-13		1B	✓	✓														
			-15	PH1-MP12-19		1B	✓	✓														
			-16	PH1-MP12-4		1B	✓	✓														
			-17	PH1-MP12-12		1B	✓	✓														
			-18	PH1-MP12-7		1B	✓	✓														
			-19	PH1-MP12-10		1B	✓	✓														
			-20	PH1-MP12-11		1B	✓	✓														
			-21	PH1-MP12-17		1B	✓	✓														
			-22	PH1-MP12-15		1B	✓	✓														

REMARKS:

CA site

Signature	Print Name	Company	Date	Time
Relinquished by				
Received by <i>Mathewine Sawyer</i>	<i>Katherine Z Souza</i>	<i>AAI</i>	<i>7-2-96</i>	<i>1030am</i>
Relinquished by				
Received by				
Relinquished by				
Received by				

NOTE: Samples are discarded 60 days after results are reported unless other arrangements are made. Hazardous samples will be returned to client or disposed of at client expense.
 *Key: AQ - Aqueous SO - Soil WA - Waste OT - Other **: L-Liter V-Voa S-Soil Jar O-Orbo T-Tedlar B-Brass P-Plastic OT-Other

Billing Information:

Name _____
 Address _____
 City, State, Zip _____
 Phone Number _____ Fax _____



Alpha Analytical, Inc.
 255 Glendale Avenue, Suite 21
 Sparks, Nevada 89431
 Phone (702) 355-1044
 Fax (702) 355-0406

Analyses Required

Client Name		P.O. #		Job #		ITPH BTRK														
Battelle				G002727-01																
Address		PWS #		DWR #																
City, State, Zip		Phone #		Fax #																
Time Sampled	Date Sampled	Matrix* See Key Below	Office Use Only Lab ID Number	Sampled by	Report Attention	Sample Description	Total and type of containers ** See below													
1030	6-28	SO	BMI 070296-C1			PH1-MPY-4	1B	✓	✓											
		SO	BMI 070296-02			PH1-MPY-5	1B	✓	✓											
		SO	-03			PH1-MPY-7	1B	✓	✓											
			-04			PH1-MPY-6	1B	✓	✓											
			-05			PH1-MPY-9	1B	✓	✓											
			-06			PH1-MPY-10	1B	✓	✓											
			-07			PH1-MPY-11	1B	✓	✓											
			-08			PH1-MPY-12	1B	✓	✓											
			-09			PH1-MPY-13	1B	✓	✓											
			-10			PH1-MPY-17	1B	✓	✓											
			-11			PH1-MPY-19	1B	✓	✓											
			-12			PH1-MPY-8	1B	✓	✓											

REMARKS:

CA SITE

Signature	Print Name	Company	Date	Time
Relinquished by				
Received by <i>Katherine Souza</i>	Katherine Souza	AAI	7-2-96	10:30am
Relinquished by				
Received by				
Relinquished by				
Received by				

NOTE: Samples are discarded 60 days after results are reported unless other arrangements are made. Hazardous samples will be returned to client or disposed of at client expense.

Proj. No.		Project Title		SAMPLE TYPE (✓)												Container No.	Number of Containers	Remarks	
G002727-01		Port Itueneme - Site 1		<div style="display: flex; justify-content: space-between;"> <div style="writing-mode: vertical-rl; transform: rotate(180deg);">TPH-8015</div> <div style="writing-mode: vertical-rl; transform: rotate(180deg);">BTEX-8240</div> </div>															
SAMPLERS: (Signature)																			
E. BLACK, C. PERRY																			
DATE	TIME	SAMPLE I.D.																	
6/29/96	11:55	PHI-MPII - 8'		✓	✓													1	Aluminum sleeve
"	"	PHI-MPII - 19'		✓	✓													"	"
"	"	PHI-MPII - 7'		✓	✓													"	"
"	"	PHI-MPII - 9'		✓	✓													"	"
"	"	PHI-MPII - 15'		✓	✓													"	"
"	"	PHI-MPII - 4'		✓	✓													"	"
"	"	PHI-MPII - 13'		✓	✓													"	"
"	"	PHI-MPII - 12'		✓	✓													"	"
"	"	PHI-MPII - 11'		✓	✓													"	"
"	"	PHI-MPII - 12'		✓	✓													"	"
"	"	PHI-MPII - 5'		✓	✓													"	"
"	"	PHI-MPII - 10'		✓	✓													"	"
6/29/96	1500	PHI-MPII - 4'		✓	✓													"	"
		PHI-MPII - 5'		✓	✓													"	"
		PHI-MPII - 7'		✓	✓													"	"
		PHI-MPII - 7' Dup.		✓	✓													"	"
		PHI-MPII - 9'		✓	✓													"	"

Relinquished by: (Signature)	Date/Time	Received by: (Signature)	Relinquished by: (Signature)	Date/Time	Received by: (Signature)
<i>[Signature]</i>	7/1/96 Spm				
Relinquished by: (Signature)	Date/Time	Received by: (Signature)	Relinquished by: (Signature)	Date/Time	Received by: (Signature)
Relinquished by: (Signature)	Date/Time	Received for Laboratory by: (Signature)	Date/Time	Remarks	
		<i>[Signature]</i>	7-746	<i>[Signature]</i>	



Battelle

Columbus Laboratories

CHAIN OF CUSTODY RECORD

Form No. _____

Proj. No.		Project Title		SAMPLE TYPE (✓)												Container No.	Number of Containers	Remarks	
SAMPLERS: (Signature)		DATE	TIME	SAMPLE I.D.	[Hatched Area]														
C.002727-01		Port Hueneme - Site 1																	
E. Black, C. Kerry																			
					<div style="display: flex; justify-content: space-between;"> TPH-8015 BTEX-8210 </div>														
6/29/96	1500	PHI-MPI-10'	✓	✓														1	Aluminum Sleeve
		PHI-MPI-11'	✓	✓															
		PHI-MPI-12'	✓	✓															
		PHI-MPI-13'	✓	✓															
		PHI-MPI-15'	✓	✓															
		PHI-MPI-17'	✓	✓															
		PHI-MPI-19'	✓	✓															
6/29/96	1948	PHI-MP8-17'	✓	✓														"	"
"	"	PHI-MP8-19'	✓	✓														"	"
"	"	PHI-MP8-13'	✓	✓														"	"
"	"	PHI-MP8-12'	✓	✓														"	"
"	"	PHI-MP8-7'	✓	✓														"	"
"	"	PHI-MP8-11'	✓	✓														"	"
"	"	PHI-MP8-10'	✓	✓														"	"
"	"	PHI-MP8-8'	✓	✓														"	"
"	"	PHI-MP8-9'	✓	✓														"	"
"	"	PHI-MP8-5'	✓	✓														"	"
Relinquished by: (Signature)		Date/Time		Received by: (Signature)		Relinquished by: (Signature)		Date/Time		Received by: (Signature)									
[Signature]		7/1/96 5pm																	
Relinquished by: (Signature)		Date/Time		Received by: (Signature)		Relinquished by: (Signature)		Date/Time		Received by: (Signature)									
Relinquished by: (Signature)		Date/Time		Received for Laboratory by: (Signature)		Date/Time		Remarks											
				Matthew Sney		7-2-96 12:30 AM													

2 of 3



Battelle

Columbus Laboratories

CHAIN OF CUSTODY RECORD

Form No. _____

Proj. No. **G002727-01** Project Title **NEX Gas Station
Port Hueneume - Site 2**

SAMPLE TYPE (✓)

SAMPLERS: (Signature)

C. J. Toney

DATE	TIME	SAMPLE I.D.
------	------	-------------

7/10/96	0940 0950	PH2-MP9-8'
}	1000	PH2-MP9-9'
	1010	PH2-MP9-10'
	1020	PH2-MP9-12'
	1030	PH2-MP9-15'
	1035	PH2-MP9-17'
7/10/96	1430	PH2-MP4-11'
	1430	PH2-MP4-12'
	1435	PH2-MP4-13'
	1435	PH2-MP4-15'
	1440	PH2-MP4-16'
	1440	PH2-MP4-17'
	1440	PH2-MP4-19'

TPH-8015 BTX-8240									
/	/								
/	/								
/	/								
/	/								
/	/								
/	/								
/	/								
/	/								
/	/								
/	/								
/	/								
/	/								
/	/								
/	/								

Container No.

Number of Containers

Soil samples in 2 3/4" dx 4" aluminum tubes w/ plastic end caps.

Remarks

Relinquished by: (Signature)	Date/Time		Received by: (Signature)	Relinquished by: (Signature)	Date/Time		Received by: (Signature)
		7/10/96 1700					
Relinquished by: (Signature)	Date/Time		Received by: (Signature)	Relinquished by: (Signature)	Date/Time		Received by: (Signature)
Relinquished by: (Signature)	Date/Time		Received for Laboratory by: (Signature)	Date/Time		Remarks	



Alpha Analytical, Inc.

255 Glendale Avenue, Suite 21
Sparks, Nevada 89431
(702) 355-1044
FAX: 702-355-0406
1-800-283-1183

e-mail: alpha@powernet.net
http://www.powernet.net/~alpha

2505 Chandler Avenue, Suite 1
Las Vegas, Nevada 89120
(702) 498-3312
FAX: 702-736-7523
1-800-283-1183

ANALYTICAL REPORT

Battelle
505 King Ave
Columbus Ohio 43201

Job#: G002727-01
Phone: (614) 424-6199
Attn: Al Pollock

Sampled: 06/27/96 Received: 06/28/96 Analyzed: 07/03-08/96

Matrix: [X] Soil [] Water [] Waste

Analysis Requested: BTEX - Benzene, Toluene, Xylenes, Ethylbenzene

Methodology: BTEX - EPA Method 624/8240

Results:

Client ID/ Lab ID	Parameter	Concentration ug/Kg	Detection Limit ug/Kg
PH1-MP10-4 /BMI062896-03	Benzene	ND	5.0
	Toluene	41	5.0
	Ethylbenzene	ND	5.0
	Total Xylenes	ND	5.0
PH1-MP10-5 /BMI062896-04	Benzene	ND	5.0
	Toluene	ND	5.0
	Ethylbenzene	ND	5.0
	Total Xylenes	ND	5.0
PH1-MP10-7 /BMI062896-05	Benzene	ND	5.0
	Toluene	5.6	5.0
	Ethylbenzene	ND	5.0
	Total Xylenes	ND	5.0
PH1-MP10-8 /BMI062896-06	Benzene	ND	5.0
	Toluene	ND	5.0
	Ethylbenzene	ND	5.0
	Total Xylenes	ND	5.0
PH1-MP10-9 /BMI062896-07	Benzene	ND	5.0
	Toluene	ND	5.0
	Ethylbenzene	ND	5.0
	Total Xylenes	ND	5.0
PH1-MP10-10 /BMI062896-08	Benzene	64	5.0
	Toluene	9.4	5.0
	Ethylbenzene	330	5.0
	Total Xylenes	ND	5.0

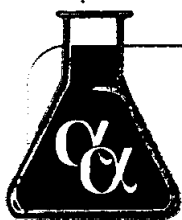

Alpha Analytical, Inc.

255 Glendale Avenue, Suite 21
Sparks, Nevada 89431
(702) 355-1044
FAX: 702-355-0406
1-800-283-1183

e-mail: alpha@powernet.net
http://www.powernet.net/~alpha

2505 Chandler Avenue, Suite 1
Las Vegas, Nevada 89120
(702) 498-3312
FAX: 702-736-7523
1-800-283-1183

Continued:

Client ID/ Lab ID	Parameter	Concentration ug/Kg	Detection Limit ug/Kg
PH1-MP10-11 /BMI062896-09	Benzene	380	5.0
	Toluene	ND	5.0
	Ethylbenzene	1,200	5.0
	Total Xylenes	690	5.0
PH1-MP10-12 /BMI062896-10	Benzene	2,500	5.0
	Toluene	ND	5.0
	Ethylbenzene	250	5.0
	Total Xylenes	290	5.0
PH1-MP10-13 /BMI062896-11	Benzene	530	5.0
	Toluene	ND	5.0
	Ethylbenzene	23	5.0
	Total Xylenes	58	5.0
PH1-MP10-15 /BMI062896-12	Benzene	36	5.0
	Toluene	ND	5.0
	Ethylbenzene	8.0	5.0
	Total Xylenes	22	5.0
PH1-MP10-19 /BMI062896-13	Benzene	ND	5.0
	Toluene	ND	5.0
	Ethylbenzene	ND	5.0
	Total Xylenes	11	5.0
PH1-MP10-17 /BMI062896-14	Benzene	ND	5.0
	Toluene	ND	5.0
	Ethylbenzene	ND	5.0
	Total Xylenes	9.5	5.0

ND - Not Detected

Approved by:

Roger L. Scholl
Roger L. Scholl, Ph.D.
Laboratory Director

Date:

7/12/96

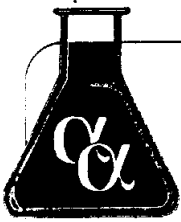

Alpha Analytical, Inc.

255 Glendale Avenue, Suite 21
Sparks, Nevada 89431
(702) 355-1044
FAX: 702-355-0406
1-800-283-1183

e-mail: alpha@powernet.net
http://www.powernet.net/~alpha

2505 Chandler Avenue, Suite 1
Las Vegas, Nevada 89120
(702) 498-3312
FAX: 702-736-7523
1-800-283-1183

ANALYTICAL REPORT

Battelle
505 King Ave
Columbus Ohio 43201

Job#: G002727-01
Phone: (614) 424-6199
Attn: Al Pollock

Sampled: 06/27/96 Received: 06/28/96 Analyzed: 07/03/96

Matrix: [X] Soil [] Water [] Waste

Analysis Requested: TPH - Total Petroleum Hydrocarbons-Purgeable
Quantitated As Gasoline

Methodology: TPH - Modified 8015/DHS LUFT Manual/BLS-191

Results:

Client ID/ Lab ID	Parameter	Concentration mg/Kg	Detection Limit mg/Kg
PH1-MP10-10 /BMI062896-08	TPH (Purgeable)	10	1.0
PH1-MP10-11 /BMI062896-09	TPH (Purgeable)	20	1.0

ND - Not Detected

Approved By: Roger L. Scholl Date: 7/12/96

Roger L. Scholl, Ph.D.
Laboratory Director

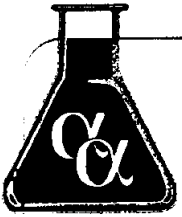

Alpha Analytical, Inc.

255 Glendale Avenue, Suite 21
Sparks, Nevada 89431
(702) 355-1044
FAX: 702-355-0406
1-800-283-1183

e-mail: alpha@powernet.net
http://www.powernet.net/~alpha

2505 Chandler Avenue, Suite 1
Las Vegas, Nevada 89120
(702) 498-3312
FAX: 702-736-7523
1-800-283-1183

ANALYTICAL REPORT

Battelle
505 King Ave
Columbus Ohio 43201

Job#: G002727-01
Phone: (614) 424-6199
Attn: Al Pollock

Sampled: 06/27/96 Received: 06/28/96 Analyzed: 07/02-04/96

Matrix: [X] Soil [] Water [] Waste

Analysis Requested: TPH (Diesel) - Total Petroleum Hydrocarbons
Extractable Quantitated as Diesel
TPH (Motor Oil) - Total Petroleum Hydrocarbons
Extractable Quantitated as Diesel

Methodology: TPH (Diesel) - Modified 8015/DHS LUFT Manual
 TPH (Motor Oil) - Modified 8015/DHS LUFT Manual

Results:

Client ID/ Lab ID	Parameter	Concentration	Detection Limit
PH1-MP10-4 /BMI062896-03	TPH (Diesel)	ND	1.0 mg/Kg
	TPH (Motor Oil)	28	10 mg/Kg
PH1-MP10-5 /BMI062896-04	TPH (Diesel)	ND	1.0 mg/Kg
	TPH (Motor Oil)	ND	10 mg/Kg
PH1-MP10-7 /BMI062896-05	TPH (Diesel)	ND	1.0 mg/Kg
	TPH (Motor Oil)	ND	10 mg/Kg
PH1-MP10-8 /BMI062896-06	TPH (Diesel)	ND	1.0 mg/Kg
	TPH (Motor Oil)	ND	10 mg/Kg
PH1-MP10-9 /BMI062896-07	TPH (Diesel)	ND	1.0 mg/Kg
	TPH (Motor Oil)	ND	10 mg/Kg
PH1-MP10-10 /BMI062896-08	TPH (Diesel)	ND	1.0 mg/Kg
	TPH (Motor Oil)	ND	10 mg/Kg
PH1-MP10-11 /BMI062896-09	TPH (Diesel)	ND	1.0 mg/Kg
	TPH (Motor Oil)	ND	10 mg/Kg
PH1-MP10-12 /BMI062896-10	TPH (Diesel)	ND	1.0 mg/Kg
	TPH (Motor Oil)	28	10 mg/Kg

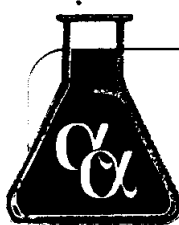

Alpha Analytical, Inc.

255 Glendale Avenue, Suite 21
Sparks, Nevada 89431
(702) 355-1044
FAX: 702-355-0406
1-800-283-1183

e-mail: alpha@powernet.net
<http://www.powernet.net/~alpha>

2505 Chandler Avenue, Suite 1
Las Vegas, Nevada 89120
(702) 498-3312
FAX: 702-736-7523
1-800-283-1183

Continued:

Client ID/ Lab ID	Parameter	Concentration	Detection Limit
PH1-MP10-13 /BMI062896-11	TPH (Diesel) TPH (Motor Oil)	ND ND	1.0 mg/Kg 10 mg/Kg
PH1-MP10-15 /BMI062896-12	TPH (Diesel) TPH (Motor Oil)	ND ND	1.0 mg/Kg 10 mg/Kg
PH1-MP10-19 /BMI062896-13	TPH (Diesel) TPH (Motor Oil)	ND ND	1.0 mg/Kg 10 mg/Kg
PH1-MP10-17 /BMI062896-14	TPH (Diesel) TPH (Motor Oil)	ND ND	1.0 mg/Kg 10 mg/Kg

Note: Hydrocarbons outside the range of diesel may have varying recoveries.

ND - Not Detected

Approved by:

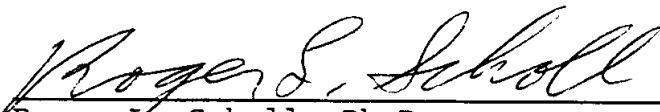
Roger L. Scholl, Ph.D.
Laboratory Director

Date:

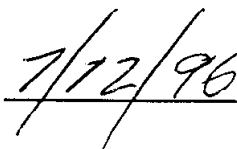

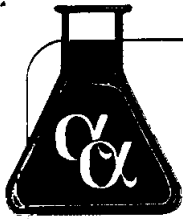

Alpha Analytical, Inc.

255 Glendale Avenue, Suite 21
Sparks, Nevada 89431
(702) 355-1044
FAX: 702-355-0406
1-800-283-1183

e-mail: alpha@powernet.net
http://www.powernet.net/~alpha

2505 Chandler Avenue, Suite 1
Las Vegas, Nevada 89120
(702) 498-3312
FAX: 702-736-7523
1-800-283-1183

ANALYTICAL REPORT

Battelle
505 King Ave
Columbus Ohio 43201

Job#: G002727-01
Phone: (614) 424-3753
Attn: Al Pollock

Sampled: 06/28/96 Received: 07/02/96 Analyzed: 07/05-11/96

Matrix: [X] Soil [] Water [] Waste

Analysis Requested: TPH (Diesel) - Total Petroleum Hydrocarbons-
Extractable Quantitated As Diesel
TPH (Motor Oil) - Total Petroleum Hydrocarbons-
Extractable Quantitated As Diesel
TPH (Gasoline) - Total Petroleum Hydrocarbons-
Purgeable Quantitated As Gasoline
BTEX - Benzene, Toluene, Ethylbenzene, Xylenes

Methodology: TPH - Modified 8015/DHS LUFT Manual/BLS-191
BTEX - EPA Method 624/8240

TPH/BTEX Results:

Client ID/ Lab ID	Parameter	Concentration	Detection Limit
PH1-MP4-4 /BMI070296-01	TPH (Diesel)	ND	1.0 mg/Kg
	TPH (Motor Oil)	ND	10 mg/Kg
	Benzene	ND	5.0 ug/Kg
	Toluene	240	5.0 ug/Kg
	Ethylbenzene	ND	5.0 ug/Kg
	Total Xylenes	ND	5.0 ug/Kg
PH1-MP4-5 /BMI070296-02	TPH (Diesel)	ND	1.0 mg/Kg
	TPH (Motor Oil)	ND	10 mg/Kg
	Benzene	ND	5.0 ug/Kg
	Toluene	68	5.0 ug/Kg
	Ethylbenzene	ND	5.0 ug/Kg
	Total Xylenes	ND	5.0 ug/Kg
PH1-MP4-7 /BMI070296-03	TPH (Diesel)	ND	1.0 mg/Kg
	TPH (Motor Oil)	ND	10 mg/Kg
	Benzene	ND	5.0 ug/Kg
	Toluene	21	5.0 ug/Kg
	Ethylbenzene	ND	5.0 ug/Kg
	Total Xylenes	ND	5.0 ug/Kg

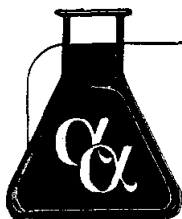

Alpha Analytical, Inc.

255 Glendale Avenue, Suite 21

Sparks, Nevada 89431

(702) 355-1044

FAX: 702-355-0406

1-800-283-1183

e-mail: alpha@powernet.net
<http://www.powernet.net/~alpha>

2505 Chandler Avenue, Suite 1

Las Vegas, Nevada 89120

(702) 498-3312

FAX: 702-736-7523

1-800-283-1183

Continued:

Client ID/ Lab ID	Parameter	Concentration	Detection Limit
PH1-MP12-4 /BMI070296-16	TPH (Diesel)	ND	1.0 mg/Kg
	TPH (Motor Oil)	24	10 mg/Kg
	Benzene	ND	5.0 ug/Kg
	Toluene	ND	5.0 ug/Kg
	Ethylbenzene	ND	5.0 ug/Kg
	Total Xylenes	ND	5.0 ug/Kg
PH1-MP12-12 /BMI070296-17	TPH (Diesel)	ND	1.0 mg/Kg
	TPH (Motor Oil)	ND	10 mg/Kg
	TPH (Gasoline)	13	1.0 mg/Kg
	Benzene	1,100	5.0 ug/Kg
	Toluene	1,000	5.0 ug/Kg
	Ethylbenzene	330	5.0 ug/Kg
	Total Xylenes	1,600	5.0 ug/Kg
PH1-MP12-7 /BMI070296-18	TPH (Diesel)	13*	1.0 mg/Kg
	TPH (Motor Oil)	ND	10 mg/Kg
	TPH (Gasoline)	4,100	500 mg/Kg**
	Benzene	8,400	1,000 ug/Kg**
	Toluene	21,000	1,000 ug/Kg**
	Ethylbenzene	46,000	1,000 ug/Kg**
	Total Xylenes	270,000	1,000 ug/Kg**
PH1-MP12-10 /BMI070296-19	TPH (Diesel)	ND	1.0 mg/Kg
	TPH (Motor Oil)	ND	10 mg/Kg
	TPH (Gasoline)	15	1.0 mg/Kg
	Benzene	69	5.0 ug/Kg
	Toluene	32	5.0 ug/Kg
	Ethylbenzene	210	5.0 ug/Kg
Total Xylenes	500	5.0 ug/Kg	
PH1-MP12-11 /BMI070296-20	TPH (Diesel)	ND	1.0 mg/Kg
	TPH (Motor Oil)	ND	10 mg/Kg
	TPH (Gasoline)	8.5	1.0 mg/Kg
	Benzene	290	5.0 ug/Kg
	Toluene	970	5.0 ug/Kg
	Ethylbenzene	410	5.0 ug/Kg
Total Xylenes	2,400	5.0 ug/Kg	

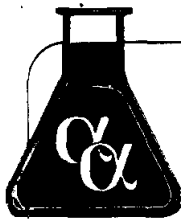

Alpha Analytical, Inc.

255 Glendale Avenue, Suite 21
Sparks, Nevada 89431
(702) 355-1044
FAX: 702-355-0406
1-800-283-1183

e-mail: alpha@power.net
http://www.power.net/~alpha

2505 Chandler Avenue, Suite 1
Las Vegas, Nevada 89120
(702) 498-3312
FAX: 702-736-7523
1-800-283-1183

Continued:

Client ID/ Lab ID	Parameter	Concentration	Detection Limit
PH1-MP12-17 /BMI070296-21	TPH (Diesel)	ND	1.0 mg/Kg
	TPH (Motor Oil)	ND	10 mg/Kg
	Benzene	17	5.0 ug/Kg
	Toluene	ND	5.0 ug/Kg
	Ethylbenzene	ND	5.0 ug/Kg
	Total Xylenes	11	5.0 ug/Kg
PH1-MP12-15 /BMI070296-22	TPH (Diesel)	ND	1.0 mg/Kg
	TPH (Motor Oil)	ND	10 mg/Kg
	Benzene	10	5.0 ug/Kg
	Toluene	78	5.0 ug/Kg
	Ethylbenzene	64	5.0 ug/Kg
	Total Xylenes	350	5.0 ug/Kg

* - Diesel concentrations are estimated due to the large amount of gasoline present.

** - Detection limit was increased due to the high level of hydrocarbon contamination.

Note: Hydrocarbons outside the range of diesel may have varying recoveries.

ND - Not Detected

Approved By:

Roger L. Scholl
Roger L. Scholl, Ph.D.
Laboratory Director

Date:

7/23/96

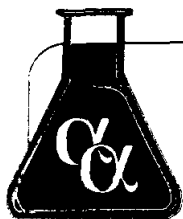

Alpha Analytical, Inc.

255 Glendale Avenue, Suite 21
Sparks, Nevada 89431
(702) 355-1044
FAX: 702-355-0406
1-800-283-1183

e-mail: alpha@power.net
http://www.power.net/~alpha

2505 Chandler Avenue, Suite 1
Las Vegas, Nevada 89120
(702) 498-3312
FAX: 702-736-7523
1-800-283-1183

ANALYTICAL REPORT

Battelle
505 King Ave
Columbus Ohio 43201

Job#: G002727-01
Phone: (614) 424-3753
Attn: Al Pollock

Sampled: 06/29-30/96 Received: 07/02/96 Analyzed: 07/08-12/96

Matrix: [X] Soil [] Water [] Waste

Analysis Requested: TPH (Diesel) - Total Petroleum Hydrocarbons-
Extractable Quantitated As Diesel
TPH (Motor Oil) - Total Petroleum Hydrocarbons-
Extractable Quantitated As Diesel
TPH (Gasoline) - Total Petroleum Hydrocarbons-
Purgeable Quantitated As Gasoline
BTEX - Benzene, Toluene, Ethylbenzene, Xylenes

Methodology: TPH - Modified 8015/DHS LUFT Manual/BLS-191
BTEX - EPA Method 624/8240

TPH/BTEX Results:

Client ID/ Lab ID	Parameter	Concentration	Detection Limit
PH1-MP11-8' /BMI070296-23	TPH (Diesel)	ND	2.0 mg/Kg*
	TPH (Motor Oil)	ND	10 mg/Kg
	TPH (Gasoline)	27	10 mg/Kg*
	Benzene	92	40 ug/Kg*
	Toluene	95	40 ug/Kg*
	Ethylbenzene	610	40 ug/Kg*
	Total Xylenes	2,600	40 ug/Kg*
PH1-MP11-19' /BMI070296-24	TPH (Diesel)	ND	1.0 mg/Kg
	TPH (Motor Oil)	ND	10 mg/Kg
	Benzene	ND	5.0 ug/Kg
	Toluene	81	5.0 ug/Kg
	Ethylbenzene	18	5.0 ug/Kg
	Total Xylenes	110	5.0 ug/Kg
PH1-MP11-7' /BMI070296-25	TPH (Diesel)	ND	1.0 mg/Kg
	TPH (Motor Oil)	ND	10 mg/Kg
	TPH (Gasoline)	5.5	1.0 mg/Kg
	Benzene	5.9	5.0 ug/Kg
	Toluene	26	5.0 ug/Kg
	Ethylbenzene	31	5.0 ug/Kg
	Total Xylenes	14	5.0 ug/Kg

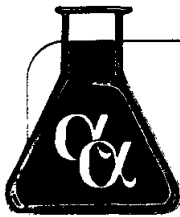

Alpha Analytical, Inc.

255 Glendale Avenue, Suite 21
Sparks, Nevada 89431
(702) 355-1044
FAX: 702-355-0406
1-800-283-1183

e-mail: alpha@powernet.net
http://www.powernet.net/~alpha

2505 Chandler Avenue, Suite 1
Las Vegas, Nevada 89120
(702) 498-3312
FAX: 702-736-7523
1-800-283-1183

Continued:

Client ID/ Lab ID	Parameter	Concentration	Detection Limit
PH1-MP11-9' /BMI070296-26	TPH (Diesel)	ND	1.0 mg/Kg
	TPH (Motor Oil)	ND	10 mg/Kg
	TPH (Gasoline)	29	20 mg/Kg*
	Benzene	140	80 ug/Kg*
	Toluene	ND	80 ug/Kg*
	Ethylbenzene	760	80 ug/Kg*
	Total Xylenes	3,800	80 ug/Kg*
PH1-MP11-15' /BMI070296-27	TPH (Diesel)	ND	1.0 mg/Kg
	TPH (Motor Oil)	ND	10 mg/Kg
	Benzene	61	5.0 ug/Kg
	Toluene	580	5.0 ug/Kg
	Ethylbenzene	220	5.0 ug/Kg
	Total Xylenes	1,200	5.0 ug/Kg
PH1-MP11-4' /BMI070296-28	TPH (Diesel)	ND	1.0 mg/Kg
	TPH (Motor Oil)	ND	10 mg/Kg
	Benzene	ND	5.0 ug/Kg
	Toluene	19	5.0 ug/Kg
	Ethylbenzene	ND	5.0 ug/Kg
	Total Xylenes	6.6	5.0 ug/Kg
PH1-MP11-13' /BMI070296-29	TPH (Diesel)	13**	1.0 mg/Kg
	TPH (Motor Oil)	ND	10 mg/Kg
	TPH (Gasoline)	1,100	250 mg/Kg*
	Benzene	7,200	1,000 ug/Kg*
	Toluene	66,000	1,000 ug/Kg*
	Ethylbenzene	38,000	1,000 ug/Kg*
	Total Xylenes	200,000	1,000 ug/Kg*
PH1-MP11-17' /BMI070296-30	TPH (Diesel)	ND	1.0 mg/Kg
	TPH (Motor Oil)	ND	10 mg/Kg
	Benzene	17	5.0 ug/Kg
	Toluene	190	5.0 ug/Kg
	Ethylbenzene	86	5.0 ug/Kg
	Total Xylenes	440	5.0 ug/Kg
PH1-MP11-11' /BMI070296-31	TPH (Diesel)	21**	1.0 mg/Kg
	TPH (Motor Oil)	ND	10 mg/Kg
	TPH (Gasoline)	860	250 mg/Kg*
	Benzene	3,500	1,000 ug/Kg*
	Toluene	41,000	1,000 ug/Kg*
	Ethylbenzene	25,000	1,000 ug/Kg*
	Total Xylenes	150,000	1,000 ug/Kg*

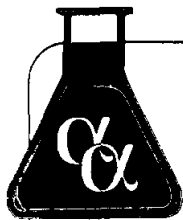

Alpha Analytical, Inc.

255 Glendale Avenue, Suite 21
Sparks, Nevada 89431
(702) 355-1044
FAX: 702-355-0406
1-800-283-1183

e-mail: alpha@powernet.net
http://www.powernet.net/~alpha

2505 Chandler Avenue, Suite 1
Las Vegas, Nevada 89120
(702) 498-3312
FAX: 702-736-7523
1-800-283-1183

Continued:

Client ID/ Lab ID	Parameter	Concentration	Detection Limit
PH1-MP11-12' /BMI070296-32	TPH (Diesel)	65**	1.0 mg/Kg
	TPH (Motor Oil)	20	10 mg/Kg
	TPH (Gasoline)	11,000	250 mg/Kg*
	Benzene	68,000	1,000 ug/Kg*
	Toluene	550,000	1,000 ug/Kg*
	Ethylbenzene	290,000	1,000 ug/Kg*
	Total Xylenes	1,300,000	1,000 ug/Kg*
PH1-MP11-5' /BMI070296-33	TPH (Diesel)	ND	1.0 mg/Kg
	TPH (Motor Oil)	ND	10 mg/Kg
	TPH (Gasoline)	6.8	1.0 mg/Kg
	Benzene	82	5.0 ug/Kg
	Toluene	450	5.0 ug/Kg
	Ethylbenzene	110	5.0 ug/Kg
	Total Xylenes	540	5.0 ug/Kg
PH1-MP11-10' /BMI070296-34	TPH (Diesel)	5.0**	1.0 mg/Kg
	TPH (Motor Oil)	ND	10 mg/Kg
	TPH (Gasoline)	56	50 mg/Kg*
	Benzene	400	200 ug/Kg*
	Toluene	1,800	200 ug/Kg*
	Ethylbenzene	1,900	200 ug/Kg*
	Total Xylenes	10,000	200 ug/Kg*
PH1-MP1-4' /BMI070296-35	TPH (Diesel)	ND	1.0 mg/Kg
	TPH (Motor Oil)	ND	10 mg/Kg
	Benzene	ND	5.0 ug/Kg
	Toluene	22	5.0 ug/Kg
	Ethylbenzene	ND	5.0 ug/Kg
	Total Xylenes	ND	5.0 ug/Kg
PH1-MP1-5' /BMI070296-36	TPH (Diesel)	ND	1.0 mg/Kg
	TPH (Motor Oil)	ND	10 mg/Kg
	Benzene	ND	5.0 ug/Kg
	Toluene	28	5.0 ug/Kg
	Ethylbenzene	ND	5.0 ug/Kg
	Total Xylenes	ND	5.0 ug/Kg
PH1-MP1-7' /BMI070296-37	TPH (Diesel)	ND	1.0 mg/Kg
	TPH (Motor Oil)	ND	10 mg/Kg
	Benzene	ND	5.0 ug/Kg
	Toluene	ND	5.0 ug/Kg
	Ethylbenzene	ND	5.0 ug/Kg
	Total Xylenes	ND	5.0 ug/Kg



Alpha Analytical, Inc.

255 Glendale Avenue, Suite 21
Sparks, Nevada 89431
(702) 355-1044
FAX: 702-355-0406
1-800-283-1183

e-mail: alpha@power.net
http://www.power.net/~alpha

2505 Chandler Avenue, Suite 1
Las Vegas, Nevada 89120
(702) 498-3312
FAX: 702-736-7523
1-800-283-1183

Continued:

Client ID/ Lab ID	Parameter	Concentration	Detection Limit
PH1-MP1-7' /BMI070296-38	TPH (Diesel)	4.4**	1.0 mg/Kg
	TPH (Motor Oil)	ND	10 mg/Kg
	TPH (Gasoline)	15	1.0 mg/Kg
	Benzene	15	5.0 ug/Kg
	Toluene	68	5.0 ug/Kg
	Ethylbenzene	200	5.0 ug/Kg
	Total Xylenes	82	5.0 ug/Kg
PH1-MP1-9' /BMI070296-39	TPH (Diesel)	ND	1.0 mg/Kg
	TPH (Motor Oil)	ND	10 mg/Kg
	Benzene	ND	5.0 ug/Kg
	Toluene	ND	5.0 ug/Kg
	Ethylbenzene	ND	5.0 ug/Kg
	Total Xylenes	ND	5.0 ug/Kg
PH1-MP1-10' /BMI070296-40	TPH (Diesel)	21**	1.0 mg/Kg
	TPH (Motor Oil)	ND	10 mg/Kg
	TPH (Gasoline)	760	100 mg/Kg*
	Benzene	ND	400 ug/Kg*
	Toluene	9,700	400 ug/Kg*
	Ethylbenzene	15,000	400 ug/Kg*
	Total Xylenes	74,000	400 ug/Kg*
PH1-MP1-11' /BMI070296-41	TPH (Diesel)	100**	1.0 mg/Kg
	TPH (Motor Oil)	29	10 mg/Kg
	TPH (Gasoline)	8,600	250 mg/Kg*
	Benzene	37,000	1,000 ug/Kg*
	Toluene	510,000	1,000 ug/Kg*
	Ethylbenzene	230,000	1,000 ug/Kg*
	Total Xylenes	1,100,000	1,000 ug/Kg*
PH1-MP1-12' /BMI070296-42	TPH (Diesel)	17**	1.0 mg/Kg
	TPH (Motor Oil)	ND	10 mg/Kg
	TPH (Gasoline)	1,400	250 mg/Kg*
	Benzene	4,700	1,000 ug/Kg*
	Toluene	40,000	1,000 ug/Kg*
	Ethylbenzene	29,000	1,000 ug/Kg*
	Total Xylenes	170,000	1,000 ug/Kg*
PH1-MP1-13' /BMI070296-43	TPH (Diesel)	ND	1.0 mg/Kg
	TPH (Motor Oil)	ND	10 mg/Kg
	TPH (Gasoline)	14	1.0 mg/Kg
	Benzene	980	5.0 ug/Kg
	Toluene	1,200	5.0 ug/Kg
	Ethylbenzene	360	5.0 ug/Kg
	Total Xylenes	1,700	5.0 ug/Kg

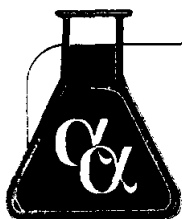

Alpha Analytical, Inc.

255 Glendale Avenue, Suite 21

Sparks, Nevada 89431

(702) 355-1044

FAX: 702-355-0406

1-800-283-1183

e-mail: alpha@powernet.net
<http://www.powernet.net/~alpha>

2505 Chandler Avenue, Suite 1

Las Vegas, Nevada 89120

(702) 498-3312

FAX: 702-736-7523

1-800-283-1183

Continued:

Client ID/ Lab ID	Parameter	Concentration	Detection Limit
PH1-MP1-15' /BMI070296-44	TPH (Diesel)	ND	1.0 mg/Kg
	TPH (Motor Oil)	ND	10 mg/Kg
	Benzene	6.3	5.0 ug/Kg
	Toluene	51	5.0 ug/Kg
	Ethylbenzene	44	5.0 ug/Kg
	Total Xylenes	270	5.0 ug/Kg
PH1-MP1-17' /BMI070296-45	TPH (Diesel)	ND	1.0 mg/Kg
	TPH (Motor Oil)	ND	10 mg/Kg
	Benzene	ND	5.0 ug/Kg
	Toluene	48	5.0 ug/Kg
	Ethylbenzene	15	5.0 ug/Kg
	Total Xylenes	84	5.0 ug/Kg
PH1-MP1-19' /BMI070296-46	TPH (Diesel)	ND	1.0 mg/Kg
	TPH (Motor Oil)	ND	10 mg/Kg
	Benzene	ND	5.0 ug/Kg
	Toluene	54	5.0 ug/Kg
	Ethylbenzene	26	5.0 ug/Kg
	Total Xylenes	160	5.0 ug/Kg
PH1-MP8-17' /BMI070296-47	TPH (Diesel)	ND	1.0 mg/Kg
	TPH (Motor Oil)	ND	10 mg/Kg
	Benzene	ND	5.0 ug/Kg
	Toluene	52	5.0 ug/Kg
	Ethylbenzene	ND	5.0 ug/Kg
	Total Xylenes	ND	5.0 ug/Kg
PH1-MP8-19' /BMI070296-48	TPH (Diesel)	ND	1.0 mg/Kg
	TPH (Motor Oil)	ND	10 mg/Kg
	Benzene	ND	5.0 ug/Kg
	Toluene	ND	5.0 ug/Kg
	Ethylbenzene	ND	5.0 ug/Kg
	Total Xylenes	ND	5.0 ug/Kg
PH1-MP8-13' /BMI070296-49	TPH (Diesel)	ND	1.0 mg/Kg
	TPH (Motor Oil)	ND	10 mg/Kg
	Benzene	130	5.0 ug/Kg
	Toluene	32	5.0 ug/Kg
	Ethylbenzene	12	5.0 ug/Kg
	Total Xylenes	ND	5.0 ug/Kg



Alpha Analytical, Inc.

255 Glendale Avenue, Suite 21
Sparks, Nevada 89431
(702) 355-1044
FAX: 702-355-0406
1-800-283-1183

e-mail: alpha@powernet.net
<http://www.powernet.net/~alpha>

2505 Chandler Avenue, Suite 1
Las Vegas, Nevada 89120
(702) 498-3312
FAX: 702-736-7523
1-800-283-1183

Continued:

Client ID/ Lab ID	Parameter	Concentration	Detection Limit
PH1-MP8-12' /BMI070296-50	TPH (Diesel)	ND	1.0 mg/Kg
	TPH (Motor Oil)	ND	10 mg/Kg
	TPH (Gasoline)	13	1.0 mg/Kg
	Benzene	340	5.0 ug/Kg
	Toluene	22	5.0 ug/Kg
	Ethylbenzene	230	5.0 ug/Kg
	Total Xylenes	15	5.0 ug/Kg
PH1-MP8-7' /BMI070296-51	TPH (Diesel)	ND	1.0 mg/Kg
	TPH (Motor Oil)	ND	10 mg/Kg
	Benzene	ND	5.0 ug/Kg
	Toluene	36	5.0 ug/Kg
	Ethylbenzene	ND	5.0 ug/Kg
	Total Xylenes	ND	5.0 ug/Kg
PH1-MP8-11' /BMI070296-52	TPH (Diesel)	ND	1.0 mg/Kg
	TPH (Motor Oil)	ND	10 mg/Kg
	Benzene	5.1	5.0 ug/Kg
	Toluene	65	5.0 ug/Kg
	Ethylbenzene	43	5.0 ug/Kg
	Total Xylenes	ND	5.0 ug/Kg
PH1-MP8-10' /BMI070296-53	TPH (Diesel)	ND	1.0 mg/Kg
	TPH (Motor Oil)	ND	10 mg/Kg
	Benzene	ND	5.0 ug/Kg
	Toluene	20	5.0 ug/Kg
	Ethylbenzene	ND	5.0 ug/Kg
	Total Xylenes	ND	5.0 ug/Kg
PH1-MP8-8' /BMI070296-54	TPH (Diesel)	ND	1.0 mg/Kg
	TPH (Motor Oil)	ND	10 mg/Kg
	Benzene	ND	5.0 ug/Kg
	Toluene	120	5.0 ug/Kg
	Ethylbenzene	ND	5.0 ug/Kg
	Total Xylenes	ND	5.0 ug/Kg
PH1-MP8-9' /BMI070296-55	TPH (Diesel)	ND	1.0 mg/Kg
	TPH (Motor Oil)	ND	10 mg/Kg
	Benzene	ND	5.0 ug/Kg
	Toluene	11	5.0 ug/Kg
	Ethylbenzene	ND	5.0 ug/Kg
	Total Xylenes	ND	5.0 ug/Kg

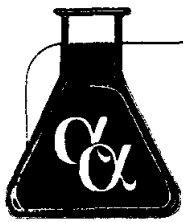

Alpha Analytical, Inc.

255 Glendale Avenue, Suite 21
Sparks, Nevada 89431
(702) 355-1044
FAX: 702-355-0406
1-800-283-1183

e-mail: alpha@powernet.net
http://www.powernet.net/~alpha

2505 Chandler Avenue, Suite 1
Las Vegas, Nevada 89120
(702) 498-3312
FAX: 702-736-7523
1-800-283-1183

Continued:

Client ID/ Lab ID	Parameter	Concentration	Detection Limit
PH1-MP8-5' /BMI070296-56	TPH (Diesel)	ND	1.0 mg/Kg
	TPH (Motor Oil)	ND	10 mg/Kg
	Benzene	ND	5.0 ug/Kg
	Toluene	100	5.0 ug/Kg
	Ethylbenzene	ND	5.0 ug/Kg
	Total Xylenes	ND	5.0 ug/Kg
PH1-MP8-4' /BMI070296-57	TPH (Diesel)	ND	1.0 mg/Kg
	TPH (Motor Oil)	ND	10 mg/Kg
	Benzene	ND	5.0 ug/Kg
	Toluene	190	5.0 ug/Kg
	Ethylbenzene	ND	5.0 ug/Kg
	Total Xylenes	ND	5.0 ug/Kg
PH1-MP8-9' /BMI070296-58	TPH (Diesel)	ND	1.0 mg/Kg
	TPH (Motor Oil)	ND	10 mg/Kg
	Benzene	130	80 ug/Kg*
	Toluene	1,100	80 ug/Kg*
	Ethylbenzene	720	80 ug/Kg*
	Total Xylenes	3,500	80 ug/Kg*
PH1-NTI-10' /BMI070296-59	TPH (Diesel)	94**	1.0 mg/Kg
	TPH (Motor Oil)	29	10 mg/Kg
	TPH (Gasoline)	10,000	1,300 mg/Kg*
	Benzene	23,000	5,000 ug/Kg*
	Toluene	530,000	5,000 ug/Kg*
	Ethylbenzene	250,000	5,000 ug/Kg*
	Total Xylenes	1,400,000	5,000 ug/Kg*
PH1-NTI-11' /BMI070296-60	TPH (Diesel)	140**	1.0 mg/Kg
	TPH (Motor Oil)	44	10 mg/Kg
	TPH (Gasoline)	17,000	1,300 mg/Kg*
	Benzene	46,000	5,000 ug/Kg*
	Toluene	870,000	5,000 ug/Kg*
	Ethylbenzene	380,000	5,000 ug/Kg*
	Total Xylenes	2,100,000	5,000 ug/Kg*
PH1-NTI-12' /BMI070296-61	TPH (Diesel)	19**	1.0 mg/Kg
	TPH (Motor Oil)	15	10 mg/Kg
	TPH (Gasoline)	940	250 mg/Kg*
	Benzene	2,000	1,000 ug/Kg*
	Toluene	16,000	1,000 ug/Kg*
	Ethylbenzene	24,000	1,000 ug/Kg*
	Total Xylenes	130,000	1,000 ug/Kg*

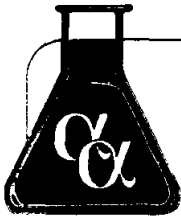

Alpha Analytical, Inc.

255 Glendale Avenue, Suite 21
Sparks, Nevada 89431
(702) 355-1044
FAX: 702-355-0406
1-800-283-1183

e-mail: alpha@powernet.net
http://www.powernet.net/~alpha

2505 Chandler Avenue, Suite 1
Las Vegas, Nevada 89120
(702) 498-3312
FAX: 702-736-7523
1-800-283-1183

Continued:

Client ID/ Lab ID	Parameter	Concentration	Detection Limit
PH1-NTI-13' /BMI070296-62	TPH (Diesel)	ND	1.0 mg/Kg
	TPH (Motor Oil)	ND	10 mg/Kg
	Benzene	21	8.0 ug/Kg*
	Toluene	170	8.0 ug/Kg*
	Ethylbenzene	120	8.0 ug/Kg*
	Total Xylenes	670	8.0 ug/Kg*
PH1-NTI-15' /BMI070296-63	TPH (Diesel)	ND	1.0 mg/Kg
	TPH (Motor Oil)	ND	10 mg/Kg
	Benzene	ND	5.0 ug/Kg
	Toluene	110	5.0 ug/Kg
	Ethylbenzene	6.5	5.0 ug/Kg
	Total Xylenes	32	5.0 ug/Kg

* - Detection limit was increased due to the high level of hydrocarbon contamination.

** - Diesel concentration is an estimate due to the high amount of gasoline present in the sample.

ND - Not Detected

Approved By:

Roger L. Scholl
Roger L. Scholl, Ph.D.
Laboratory Director

Date:

7/26/96

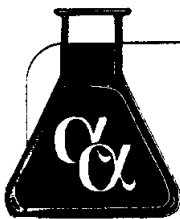

Alpha Analytical, Inc.

255 Glendale Avenue, Suite 21
Sparks, Nevada 89431
(702) 355-1044
FAX: 702-355-0406
1-800-283-1183

e-mail: alpha@power.net
<http://www.power.net/~alpha>

2505 Chandler Avenue, Suite 1
Las Vegas, Nevada 89120
(702) 498-3312
FAX: 702-736-7523
1-800-283-1183

Continued:

Client ID/ Lab ID	Parameter	Concentration	Detection Limit
PH1-MP4-6 /BMI070296-04	TPH (Diesel)	ND	1.0 mg/Kg
	TPH (Motor Oil)	ND	10 mg/Kg
	Benzene	ND	5.0 ug/Kg
	Toluene	35	5.0 ug/Kg
	Ethylbenzene	ND	5.0 ug/Kg
	Total Xylenes	ND	5.0 ug/Kg
PH1-MP4-9 /BMI070296-05	TPH (Diesel)	ND	1.0 mg/Kg
	TPH (Motor Oil)	ND	10 mg/Kg
	Benzene	ND	5.0 ug/Kg
	Toluene	ND	5.0 ug/Kg
	Ethylbenzene	ND	5.0 ug/Kg
	Total Xylenes	ND	5.0 ug/Kg
PH1-MP4-10 /BMI070296-06	TPH (Diesel)	ND	1.0 mg/Kg
	TPH (Motor Oil)	ND	10 mg/Kg
	Benzene	ND	5.0 ug/Kg
	Toluene	ND	5.0 ug/Kg
	Ethylbenzene	ND	5.0 ug/Kg
	Total Xylenes	ND	5.0 ug/Kg
PH1-MP4-11 /BMI070296-07	TPH (Diesel)	55*	1.0 mg/Kg
	TPH (Motor Oil)	17	10 mg/Kg
	Benzene	ND	1,000 ug/Kg**
	Toluene	ND	1,000 ug/Kg**
	Ethylbenzene	13,000	1,000 ug/Kg**
	Total Xylenes	6,300	1,000 ug/Kg**
PH1-MP4-12 /BMI070296-08	TPH (Diesel)	ND	1.0 mg/Kg
	TPH (Motor Oil)	ND	10 mg/Kg
	TPH (Gasoline)	7.1	1.0 mg/Kg
	Benzene	19	5.0 ug/Kg
	Toluene	46	5.0 ug/Kg
	Ethylbenzene	110	5.0 ug/Kg
	Total Xylenes	71	5.0 ug/Kg
PH1-MP4-13 /BMI070296-09	TPH (Diesel)	14*	1.0 mg/Kg
	TPH (Motor Oil)	ND	10 mg/Kg
	TPH (Gasoline)	3.5	1.0 mg/Kg
	Benzene	13	5.0 ug/Kg
	Toluene	27	5.0 ug/Kg
	Ethylbenzene	85	5.0 ug/Kg
Total Xylenes	43	5.0 ug/Kg	

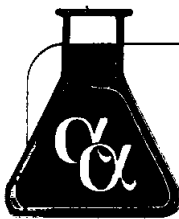

Alpha Analytical, Inc.

255 Glendale Avenue, Suite 21
Sparks, Nevada 89431
(702) 355-1044
FAX: 702-355-0406
1-800-283-1183

e-mail: alpha@powernet.net
http://www.powernet.net/~alpha

2505 Chandler Avenue, Suite 1
Las Vegas, Nevada 89120
(702) 498-3312
FAX: 702-736-7523
1-800-283-1183

Continued:

Client ID/ Lab ID	Parameter	Concentration	Detection Limit
PH1-MP4-17 /BMI070296-10	TPH (Diesel)	ND	1.0 mg/Kg
	TPH (Motor Oil)	ND	10 mg/Kg
	Benzene	ND	5.0 ug/Kg
	Toluene	25	5.0 ug/Kg
	Ethylbenzene	ND	5.0 ug/Kg
	Total Xylenes	ND	5.0 ug/Kg
PH1-MP4-19 /BMI070296-11	TPH (Diesel)	ND	1.0 mg/Kg
	TPH (Motor Oil)	ND	10 mg/Kg
	Benzene	ND	5.0 ug/Kg
	Toluene	14	5.0 ug/Kg
	Ethylbenzene	ND	5.0 ug/Kg
	Total Xylenes	ND	5.0 ug/Kg
PH1-MP12-8 /BMI070296-12	TPH (Diesel)	12*	1.0 mg/Kg
	TPH (Motor Oil)	ND	10 mg/Kg
	TPH (Gasoline)	290	50 mg/Kg**
	Benzene	760	200 ug/Kg**
	Toluene	750	200 ug/Kg**
	Ethylbenzene	5,100	200 ug/Kg**
	Total Xylenes	27,000	200 ug/Kg**
PH1-MP12-9 /BMI070296-13	TPH (Diesel)	ND	1.0 mg/Kg
	TPH (Motor Oil)	ND	10 mg/Kg
	TPH (Gasoline)	16	1.0 mg/Kg
	Benzene	140	5.0 ug/Kg
	Toluene	12	5.0 ug/Kg
	Ethylbenzene	290	5.0 ug/Kg
	Total Xylenes	630	5.0 ug/Kg
PH1-MP12-13 /BMI070296-14	TPH (Diesel)	27*	1.0 mg/Kg
	TPH (Motor Oil)	ND	10 mg/Kg
	TPH (Gasoline)	250	100 mg/Kg**
	Benzene	3,100	400 ug/Kg**
	Toluene	5,400	400 ug/Kg**
	Ethylbenzene	3,100	400 ug/Kg**
	Total Xylenes	18,000	400 ug/Kg**
PH1-MP12-19 /BMI070296-15	TPH (Diesel)	ND	1.0 mg/Kg
	TPH (Motor Oil)	ND	10 mg/Kg
	Benzene	9.5	5.0 ug/Kg
	Toluene	18	5.0 ug/Kg
	Ethylbenzene	7.8	5.0 ug/Kg
	Total Xylenes	46	5.0 ug/Kg



Alpha Analytical, Inc.

255 Glendale Avenue, Suite 21
Sparks, Nevada 89431
(702) 355-1044
FAX: 702-355-0406
1-800-283-1183

e-mail: alpha@powernet.net
http://www.powernet.net/~alpha

2505 Chandler Avenue, Suite 1
Las Vegas, Nevada 89120
(702) 498-3312
FAX: 702-736-7523
1-800-283-1183

ANALYTICAL REPORT

Battelle
505 King Ave
Columbus Ohio 43201

Job#: G002727-01
Phone: (614) 424-3753
Attn: Al Pollock

Sampled: 07/09-10/96 Received: 07/11/96 Analyzed: 07/13-17/96

Matrix: [X] Soil [] Water [] Waste

Analysis Requested: TPH (Diesel) - Total Petroleum Hydrocarbons-
Extractable Quantitated As Diesel
TPH (Motor Oil) - Total Petroleum Hydrocarbons-
Extractable Quantitated As Diesel
BTEX - Benzene, Toluene, Ethylbenzene, Xylenes

Methodology: TPH - Modified 8015/DHS LUFT Manual/BLS-191
BTEX - EPA Method 624/8240

TPH/BTEX Results:

Client ID/ Lab ID	Parameter	Concentration	Detection Limit
PH2-MP5-4 /BMI071196-01	TPH (Diesel)	ND	1.0 mg/Kg
	TPH (Motor Oil)	ND	10 mg/Kg
	Benzene	ND	5.0 ug/Kg
	Toluene	57	5.0 ug/Kg
	Ethylbenzene	ND	5.0 ug/Kg
	Total Xylenes	ND	5.0 ug/Kg
PH2-MP5-5 /BMI071196-02	TPH (Diesel)	ND	1.0 mg/Kg
	TPH (Motor Oil)	ND	10 mg/Kg
	Benzene	ND	5.0 ug/Kg
	Toluene	80	5.0 ug/Kg
	Ethylbenzene	ND	5.0 ug/Kg
	Total Xylenes	ND	5.0 ug/Kg
PH2-MP5-8 /BMI071196-03	TPH (Diesel)	ND	1.0 mg/Kg
	TPH (Motor Oil)	ND	10 mg/Kg
	Benzene	ND	5.0 ug/Kg
	Toluene	ND	5.0 ug/Kg
	Ethylbenzene	ND	5.0 ug/Kg
	Total Xylenes	ND	5.0 ug/Kg

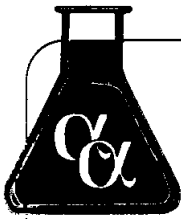
**Alpha Analytical, Inc.**

255 Glendale Avenue, Suite 21
Sparks, Nevada 89431
(702) 355-1044
FAX: 702-355-0406
1-800-283-1183

e-mail: alpha@powernet.net
http://www.powernet.net/~alpha

2505 Chandler Avenue, Suite 1
Las Vegas, Nevada 89120
(702) 498-3312
FAX: 702-736-7523
1-800-283-1183

Continued:

Client ID/ Lab ID	Parameter	Concentration	Detection Limit
PH2-MP5-9 /BMI071196-04	TPH (Diesel)	ND	1.0 mg/Kg
	TPH (Motor Oil)	ND	10 mg/Kg
	Benzene	ND	5.0 ug/Kg
	Toluene	32	5.0 ug/Kg
	Ethylbenzene	ND	5.0 ug/Kg
	Total Xylenes	ND	5.0 ug/Kg
PH2-MP5-10 /BMI071196-05	TPH (Diesel)	ND	1.0 mg/Kg
	TPH (Motor Oil)	ND	10 mg/Kg
	Benzene	ND	5.0 ug/Kg
	Toluene	ND	5.0 ug/Kg
	Ethylbenzene	ND	5.0 ug/Kg
	Total Xylenes	ND	5.0 ug/Kg
PH2-MP5-15 /BMI071196-06	TPH (Diesel)	ND	1.0 mg/Kg
	TPH (Motor Oil)	ND	10 mg/Kg
	Benzene	ND	5.0 ug/Kg
	Toluene	ND	5.0 ug/Kg
	Ethylbenzene	ND	5.0 ug/Kg
	Total Xylenes	ND	5.0 ug/Kg
PH2-MP5-17 /BMI071196-07	TPH (Diesel)	ND	1.0 mg/Kg
	TPH (Motor Oil)	ND	10 mg/Kg
	Benzene	ND	5.0 ug/Kg
	Toluene	ND	5.0 ug/Kg
	Ethylbenzene	ND	5.0 ug/Kg
	Total Xylenes	ND	5.0 ug/Kg
PH2-MP5-19 /BMI071196-08	TPH (Diesel)	ND	1.0 mg/Kg
	TPH (Motor Oil)	ND	10 mg/Kg
	Benzene	ND	5.0 ug/Kg
	Toluene	ND	5.0 ug/Kg
	Ethylbenzene	ND	5.0 ug/Kg
	Total Xylenes	ND	5.0 ug/Kg
PH2-MP11-8 /BMI071196-09	TPH (Diesel)	ND	1.0 mg/Kg
	TPH (Motor Oil)	ND	10 mg/Kg
	Benzene	ND	5.0 ug/Kg
	Toluene	ND	5.0 ug/Kg
	Ethylbenzene	ND	5.0 ug/Kg
	Total Xylenes	ND	5.0 ug/Kg

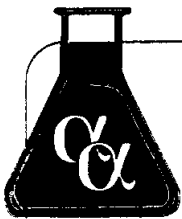

Alpha Analytical, Inc.

255 Glendale Avenue, Suite 21
Sparks, Nevada 89431
(702) 355-1044
FAX: 702-355-0406
1-800-283-1183

e-mail: alpha@powernet.net
<http://www.powernet.net/~alpha>

2505 Chandler Avenue, Suite 1
Las Vegas, Nevada 89120
(702) 498-3312
FAX: 702-736-7523
1-800-283-1183

Continued:

Client ID/ Lab ID	Parameter	Concentration	Detection Limit
PH2-MP11-9 /BMI071196-10	TPH (Diesel)	ND	1.0 mg/Kg
	TPH (Motor Oil)	ND	10 mg/Kg
	Benzene	ND	5.0 ug/Kg
	Toluene	ND	5.0 ug/Kg
	Ethylbenzene	ND	5.0 ug/Kg
	Total Xylenes	ND	5.0 ug/Kg
PH2-MP11-11 /BMI071196-11	TPH (Diesel)	ND	1.0 mg/Kg
	TPH (Motor Oil)	ND	10 mg/Kg
	Benzene	ND	5.0 ug/Kg
	Toluene	ND	5.0 ug/Kg
	Ethylbenzene	ND	5.0 ug/Kg
	Total Xylenes	ND	5.0 ug/Kg
PH2-MP11-15 /BMI071196-12	TPH (Diesel)	ND	1.0 mg/Kg
	TPH (Motor Oil)	ND	10 mg/Kg
	Benzene	ND	5.0 ug/Kg
	Toluene	ND	5.0 ug/Kg
	Ethylbenzene	ND	5.0 ug/Kg
	Total Xylenes	ND	5.0 ug/Kg
PH2-MP11-17 /BMI071196-13	TPH (Diesel)	ND	1.0 mg/Kg
	TPH (Motor Oil)	ND	10 mg/Kg
	Benzene	ND	5.0 ug/Kg
	Toluene	ND	5.0 ug/Kg
	Ethylbenzene	ND	5.0 ug/Kg
	Total Xylenes	ND	5.0 ug/Kg
PH2-MP11-19 /BMI071196-14	TPH (Diesel)	ND	1.0 mg/Kg
	TPH (Motor Oil)	ND	10 mg/Kg
	Benzene	ND	5.0 ug/Kg
	Toluene	ND	5.0 ug/Kg
	Ethylbenzene	ND	5.0 ug/Kg
	Total Xylenes	ND	5.0 ug/Kg
PH2-MP9-8 /BMI071196-15	TPH (Diesel)	ND	1.0 mg/Kg
	TPH (Motor Oil)	ND	10 mg/Kg
	Benzene	ND	5.0 ug/Kg
	Toluene	ND	5.0 ug/Kg
	Ethylbenzene	ND	5.0 ug/Kg
	Total Xylenes	ND	5.0 ug/Kg

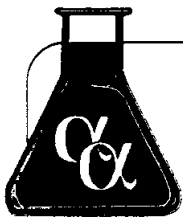

Alpha Analytical, Inc.

255 Glendale Avenue, Suite 21
Sparks, Nevada 89431
(702) 355-1044
FAX: 702-355-0406
1-800-283-1183

e-mail: alpha@powernet.net
<http://www.powernet.net/~alpha>

2505 Chandler Avenue, Suite 1
Las Vegas, Nevada 89120
(702) 498-3312
FAX: 702-736-7523
1-800-283-1183

Continued:

Client ID/ Lab ID	Parameter	Concentration	Detection Limit
PH2-MP9-9 /BMI071196-16	TPH (Diesel)	ND	1.0 mg/Kg
	TPH (Motor Oil)	ND	10 mg/Kg
	Benzene	ND	5.0 ug/Kg
	Toluene	ND	5.0 ug/Kg
	Ethylbenzene	ND	5.0 ug/Kg
	Total Xylenes	ND	5.0 ug/Kg
PH2-MP9-10 /BMI071196-17	TPH (Diesel)	ND	1.0 mg/Kg
	TPH (Motor Oil)	ND	10 mg/Kg
	Benzene	ND	5.0 ug/Kg
	Toluene	ND	5.0 ug/Kg
	Ethylbenzene	ND	5.0 ug/Kg
	Total Xylenes	ND	5.0 ug/Kg
PH2-MP9-12 /BMI071196-18	TPH (Diesel)	ND	1.0 mg/Kg
	TPH (Motor Oil)	ND	10 mg/Kg
	Benzene	ND	5.0 ug/Kg
	Toluene	ND	5.0 ug/Kg
	Ethylbenzene	ND	5.0 ug/Kg
	Total Xylenes	ND	5.0 ug/Kg
PH2-MP9-15 /BMI071196-19	TPH (Diesel)	ND	1.0 mg/Kg
	TPH (Motor Oil)	ND	10 mg/Kg
	Benzene	ND	5.0 ug/Kg
	Toluene	ND	5.0 ug/Kg
	Ethylbenzene	ND	5.0 ug/Kg
	Total Xylenes	ND	5.0 ug/Kg
PH2-MP9-17 /BMI071196-20	TPH (Diesel)	ND	1.0 mg/Kg
	TPH (Motor Oil)	ND	10 mg/Kg
	Benzene	ND	5.0 ug/Kg
	Toluene	ND	5.0 ug/Kg
	Ethylbenzene	ND	5.0 ug/Kg
	Total Xylenes	ND	5.0 ug/Kg
PH2-MP9-19 /BMI071196-21	TPH (Diesel)	ND	1.0 mg/Kg
	TPH (Motor Oil)	ND	10 mg/Kg
	Benzene	ND	5.0 ug/Kg
	Toluene	ND	5.0 ug/Kg
	Ethylbenzene	ND	5.0 ug/Kg
	Total Xylenes	ND	5.0 ug/Kg

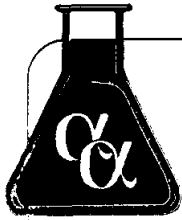

Alpha Analytical, Inc.

255 Glendale Avenue, Suite 21
Sparks, Nevada 89431
(702) 355-1044
FAX: 702-355-0406
1-800-283-1183

e-mail: alpha@powernet.net
<http://www.powernet.net/~alpha>

2505 Chandler Avenue, Suite 1
Las Vegas, Nevada 89120
(702) 498-3312
FAX: 702-736-7523
1-800-283-1183

Continued:

Client ID/ Lab ID	Parameter	Concentration	Detection Limit
PH2-MP4-11 /BMI071196-22	TPH (Diesel)	ND	1.0 mg/Kg
	TPH (Motor Oil)	ND	10 mg/Kg
	Benzene	ND	5.0 ug/Kg
	Toluene	ND	5.0 ug/Kg
	Ethylbenzene	ND	5.0 ug/Kg
	Total Xylenes	ND	5.0 ug/Kg
PH2-MP4-12 /BMI071196-23	TPH (Diesel)	ND	1.0 mg/Kg
	TPH (Motor Oil)	ND	10 mg/Kg
	Benzene	ND	5.0 ug/Kg
	Toluene	ND	5.0 ug/Kg
	Ethylbenzene	ND	5.0 ug/Kg
	Total Xylenes	ND	5.0 ug/Kg
PH2-MP4-13 /BMI071196-24	TPH (Diesel)	ND	1.0 mg/Kg
	TPH (Motor Oil)	ND	10 mg/Kg
	Benzene	ND	5.0 ug/Kg
	Toluene	ND	5.0 ug/Kg
	Ethylbenzene	ND	5.0 ug/Kg
	Total Xylenes	ND	5.0 ug/Kg
PH2-MP4-15 /BMI071196-25	TPH (Diesel)	ND	1.0 mg/Kg
	TPH (Motor Oil)	ND	10 mg/Kg
	Benzene	ND	5.0 ug/Kg
	Toluene	ND	5.0 ug/Kg
	Ethylbenzene	ND	5.0 ug/Kg
	Total Xylenes	ND	5.0 ug/Kg
PH2-MP4-16 /BMI071196-26	TPH (Diesel)	ND	1.0 mg/Kg
	TPH (Motor Oil)	ND	10 mg/Kg
	Benzene	ND	5.0 ug/Kg
	Toluene	ND	5.0 ug/Kg
	Ethylbenzene	ND	5.0 ug/Kg
	Total Xylenes	ND	5.0 ug/Kg
PH2-MP4-17 /BMI071196-27	TPH (Diesel)	ND	1.0 mg/Kg
	TPH (Motor Oil)	ND	10 mg/Kg
	Benzene	ND	5.0 ug/Kg
	Toluene	ND	5.0 ug/Kg
	Ethylbenzene	ND	5.0 ug/Kg
	Total Xylenes	ND	5.0 ug/Kg

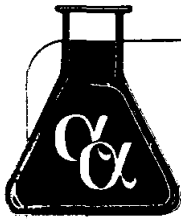

Alpha Analytical, Inc.

255 Glendale Avenue, Suite 21
Sparks, Nevada 89431
(702) 355-1044
FAX: 702-355-0406
1-800-283-1183

e-mail: alpha@powernet.net
http://www.powernet.net/~alpha

2505 Chandler Avenue, Suite 1
Las Vegas, Nevada 89120
(702) 498-3312
FAX: 702-736-7523
1-800-283-1183

Continued:

Client ID/ Lab ID	Parameter	Concentration	Detection Limit
PH2-MP4-19	TPH (Diesel)	ND	1.0 mg/Kg
/BMI071196-28	TPH (Motor Oil)	ND	10 mg/Kg
	Benzene	ND	5.0 ug/Kg
	Toluene	ND	5.0 ug/Kg
	Ethylbenzene	ND	5.0 ug/Kg
	Total Xylenes	ND	5.0 ug/Kg

ND - Not Detected

Approved By:

Roger L. Scholl
Roger L. Scholl, Ph.D.
Laboratory Director

Date:

7/26/96



Alpha Analytical, Inc.

255 Glendale Avenue, Suite 21
Sparks, Nevada 89431
(702) 355-1044
FAX: 702-355-0406
1-800-283-1183

e-mail: alpha@powernet.net
http://www.powernet.net/~alpha

2505 Chandler Avenue, Suite 1
Las Vegas, Nevada 89120
(702) 498-3312
FAX: 702-736-7523
1-800-283-1183

ANALYTICAL REPORT

Battelle
505 King Ave
Columbus Ohio 43201

Job#: G002727-01
Phone: (614) 424-3753
Attn: Al Pollock

Sampled: 07/09/96 Received: 07/10/96 Analyzed: 07/13-18/96

Matrix: [X] Soil [] Water [] Waste

Analysis Requested: TPH (Diesel) - Total Petroleum Hydrocarbons-
Extractable Quantitated As Diesel
TPH (Motor Oil) - Total Petroleum Hydrocarbons-
Extractable Quantitated As Diesel
BTEX - Benzene, Toluene, Ethylbenzene, Xylenes

Methodology: TPH - Modified 8015/DHS LUFT Manual/BLS-191
 BTEX - EPA Method 624/8240

TPH/BTEX Results:

Client ID/ Lab ID	Parameter	Concentration	Detection Limit
PH2-MP2-8 /BMI071096-01	TPH (Diesel)	ND	1.0 mg/Kg
	TPH (Motor Oil)	ND	10 mg/Kg
	Benzene	ND	5.0 ug/Kg
	Toluene	ND	5.0 ug/Kg
	Ethylbenzene	ND	5.0 ug/Kg
	Total Xylenes	ND	5.0 ug/Kg
PH2-MP2-9 /BMI071096-02	TPH (Diesel)	ND	1.0 mg/Kg
	TPH (Motor Oil)	ND	10 mg/Kg
	Benzene	ND	5.0 ug/Kg
	Toluene	ND	5.0 ug/Kg
	Ethylbenzene	ND	5.0 ug/Kg
	Total Xylenes	ND	5.0 ug/Kg
PH2-MP2-10 /BMI071096-03	TPH (Diesel)	ND	1.0 mg/Kg
	TPH (Motor Oil)	ND	10 mg/Kg
	Benzene	50	5.0 ug/Kg
	Toluene	ND	5.0 ug/Kg
	Ethylbenzene	ND	5.0 ug/Kg
	Total Xylenes	ND	5.0 ug/Kg

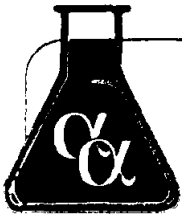

Alpha Analytical, Inc.

255 Glendale Avenue, Suite 21
Sparks, Nevada 89431
(702) 355-1044
FAX: 702-355-0406
1-800-283-1183

e-mail: alpha@powernet.net
<http://www.powernet.net/~alpha>

2505 Chandler Avenue, Suite 1
Las Vegas, Nevada 89120
(702) 498-3312
FAX: 702-736-7523
1-800-283-1183

Continued:

Client ID/ Lab ID	Parameter	Concentration	Detection Limit
PH2-MP2-11 /BMI071096-04	TPH (Diesel)	ND	1.0 mg/Kg
	TPH (Motor Oil)	ND	10 mg/Kg
	Benzene	ND	5.0 ug/Kg
	Toluene	ND	5.0 ug/Kg
	Ethylbenzene	ND	5.0 ug/Kg
	Total Xylenes	ND	5.0 ug/Kg
PH2-MP2-12 /BMI071096-05	TPH (Diesel)	ND	1.0 mg/Kg
	TPH (Motor Oil)	ND	10 mg/Kg
	Benzene	ND	5.0 ug/Kg
	Toluene	ND	5.0 ug/Kg
	Ethylbenzene	ND	5.0 ug/Kg
	Total Xylenes	ND	5.0 ug/Kg
PH2-MP2-13 /BMI071096-06	TPH (Diesel)	ND	1.0 mg/Kg
	TPH (Motor Oil)	ND	10 mg/Kg
	Benzene	ND	5.0 ug/Kg
	Toluene	ND	5.0 ug/Kg
	Ethylbenzene	ND	5.0 ug/Kg
	Total Xylenes	ND	5.0 ug/Kg
PH2-MP2-15 /BMI071096-07	TPH (Diesel)	ND	1.0 mg/Kg
	TPH (Motor Oil)	ND	10 mg/Kg
	Benzene	ND	5.0 ug/Kg
	Toluene	ND	5.0 ug/Kg
	Ethylbenzene	ND	5.0 ug/Kg
	Total Xylenes	ND	5.0 ug/Kg
PH2-MP2-17 /BMI071096-08	TPH (Diesel)	ND	1.0 mg/Kg
	TPH (Motor Oil)	ND	10 mg/Kg
	Benzene	ND	5.0 ug/Kg
	Toluene	ND	5.0 ug/Kg
	Ethylbenzene	ND	5.0 ug/Kg
	Total Xylenes	ND	5.0 ug/Kg
PH2-MP2-19 /BMI071096-09	TPH (Diesel)	ND	1.0 mg/Kg
	TPH (Motor Oil)	ND	10 mg/Kg
	Benzene	ND	5.0 ug/Kg
	Toluene	ND	5.0 ug/Kg
	Ethylbenzene	ND	5.0 ug/Kg
	Total Xylenes	ND	5.0 ug/Kg



Alpha Analytical, Inc.

255 Glendale Avenue, Suite 21

Sparks, Nevada 89431

(702) 355-1044

FAX: 702-355-0406

1-800-283-1183

e-mail: alpha@powernet.net

<http://www.powernet.net/~alpha>

2505 Chandler Avenue, Suite 1

Las Vegas, Nevada 89120

(702) 498-3312

FAX: 702-736-7523

1-800-283-1183

Continued:

Client ID/ Lab ID	Parameter	Concentration	Detection Limit
PH2-MP8-4 /BMI071096-10	TPH (Diesel)	ND	1.0 mg/Kg
	TPH (Motor Oil)	ND	10 mg/Kg
	Benzene	ND	5.0 ug/Kg
	Toluene	ND	5.0 ug/Kg
	Ethylbenzene	ND	5.0 ug/Kg
	Total Xylenes	ND	5.0 ug/Kg
PH2-MP8-5 /BMI071096-11	TPH (Diesel)	ND	1.0 mg/Kg
	TPH (Motor Oil)	ND	10 mg/Kg
	Benzene	ND	5.0 ug/Kg
	Toluene	ND	5.0 ug/Kg
	Ethylbenzene	ND	5.0 ug/Kg
	Total Xylenes	ND	5.0 ug/Kg
PH2-MP8-8 /BMI071096-12	TPH (Diesel)	ND	1.0 mg/Kg
	TPH (Motor Oil)	ND	10 mg/Kg
	Benzene	ND	5.0 ug/Kg
	Toluene	ND	5.0 ug/Kg
	Ethylbenzene	ND	5.0 ug/Kg
	Total Xylenes	ND	5.0 ug/Kg
PH2-MP8-11 /BMI071096-13	TPH (Diesel)	ND	1.0 mg/Kg
	TPH (Motor Oil)	ND	10 mg/Kg
	Benzene	ND	5.0 ug/Kg
	Toluene	ND	5.0 ug/Kg
	Ethylbenzene	ND	5.0 ug/Kg
	Total Xylenes	ND	5.0 ug/Kg
PH2-MP8-12 /BMI071096-14	TPH (Diesel)	ND	1.0 mg/Kg
	TPH (Motor Oil)	ND	10 mg/Kg
	Benzene	ND	5.0 ug/Kg
	Toluene	ND	5.0 ug/Kg
	Ethylbenzene	ND	5.0 ug/Kg
	Total Xylenes	ND	5.0 ug/Kg
PH2-MP8-17 /BMI071096-15	TPH (Diesel)	ND	1.0 mg/Kg
	TPH (Motor Oil)	ND	10 mg/Kg
	Benzene	ND	5.0 ug/Kg
	Toluene	21	5.0 ug/Kg
	Ethylbenzene	ND	5.0 ug/Kg
	Total Xylenes	ND	5.0 ug/Kg

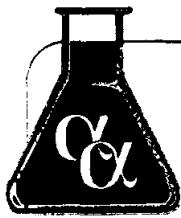

Alpha Analytical, Inc.

255 Glendale Avenue, Suite 21

Sparks, Nevada 89431

(702) 355-1044

FAX: 702-355-0406

1-800-283-1183

e-mail: alpha@powernet.net
<http://www.powernet.net/~alpha>

2505 Chandler Avenue, Suite 1

Las Vegas, Nevada 89109

(702) 498-3512

FAX: 702-736-7523

1-800-283-1183

Continued:

Client ID/ Lab ID	Parameter	Concentration	Detection Limit
PH2-MP6-4 /BMI071096-16	TPH (Diesel)	ND	1.0 mg/Kg
	TPH (Motor Oil)	ND	10 mg/Kg
	Benzene	ND	5.0 ug/Kg
	Toluene	59	5.0 ug/Kg
	Ethylbenzene	ND	5.0 ug/Kg
	Total Xylenes	ND	5.0 ug/Kg
PH2-MP6-5 /BMI071096-17	TPH (Diesel)	ND	1.0 mg/Kg
	TPH (Motor Oil)	ND	10 mg/Kg
	Benzene	ND	5.0 ug/Kg
	Toluene	ND	5.0 ug/Kg
	Ethylbenzene	ND	5.0 ug/Kg
	Total Xylenes	ND	5.0 ug/Kg
PH2-MP6-7 /BMI071096-18	TPH (Diesel)	ND	1.0 mg/Kg
	TPH (Motor Oil)	ND	10 mg/Kg
	Benzene	ND	5.0 ug/Kg
	Toluene	ND	5.0 ug/Kg
	Ethylbenzene	ND	5.0 ug/Kg
	Total Xylenes	ND	5.0 ug/Kg
PH2-MP6-8 /BMI071096-19	TPH (Diesel)	ND	1.0 mg/Kg
	TPH (Motor Oil)	ND	10 mg/Kg
	Benzene	ND	5.0 ug/Kg
	Toluene	ND	5.0 ug/Kg
	Ethylbenzene	ND	5.0 ug/Kg
	Total Xylenes	ND	5.0 ug/Kg
PH2-MP6-9 /BMI071096-20	TPH (Diesel)	ND	1.0 mg/Kg
	TPH (Motor Oil)	ND	10 mg/Kg
	Benzene	ND	5.0 ug/Kg
	Toluene	ND	5.0 ug/Kg
	Ethylbenzene	ND	5.0 ug/Kg
	Total Xylenes	ND	5.0 ug/Kg
PH2-MP6-10 /BMI071096-21	TPH (Diesel)	ND	1.0 mg/Kg
	TPH (Motor Oil)	ND	10 mg/Kg
	Benzene	ND	5.0 ug/Kg
	Toluene	ND	5.0 ug/Kg
	Ethylbenzene	ND	5.0 ug/Kg
	Total Xylenes	ND	5.0 ug/Kg

Proj. No. CP 2727-φ1
 Project Title VEX Gas Station Port Hueneheme-site 2

SAMPLE TYPE (√)

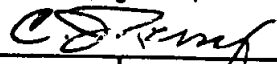
SAMPLERS: (Signature)

DATE	TIME	SAMPLE I.D.
------	------	-------------

PH2-8015 BTEX-8240										Container No.	Number of Containers	Soil samples in 2 3/4" d x 4" aluminum tubes w/ plastic end caps. Remarks
(Grid area for sample types)												

7/9/96	1450	PH2-MP5-4	/	/																
	1450	PH2-MP5-5	/	/																
	1455	PH2-MP5-8	/	/																
	1500	PH2-MP5-9	/	/																
	1510	PH2-MP5-10	/	/																
	1515	PH2-MP5-15	/	/																
	1520	PH2-MP5-17	/	/																
	1525	PH2-MP5-2019	/	/																

7/10/96	0810	PH2-MP11-8																		
	0810	PH2-MP11-9																		
	0820	PH2-MP11-11																		
	0830	PH2-MP11-15																		
	0840	PH2-MP11-17																		
	0850	PH2-MP11-19																		

Relinquished by: (Signature) 	Date/Time	Received by: (Signature)	Relinquished by: (Signature)	Date/Time	Received by: (Signature)
	7/10/96 1700				
Relinquished by: (Signature)	Date/Time	Received by: (Signature)	Relinquished by: (Signature)	Date/Time	Received by: (Signature)
Relinquished by: (Signature)	Date/Time	Received for Laboratory by: (Signature)	Date/Time	Remarks	

ing Information:

SS _____
 State, Zip _____
 Number _____ Fax _____



Alpha Analytical, Inc.
 255 Glendale Avenue, Suite 21
 Sparks, Nevada 89431
 Phone (702) 355-1044
 Fax (702) 355-0406

Analyses Required

Name Battelle P.O. # _____ Job # _____
 PWS # _____ DWR # _____
 Phone # _____ Fax # _____

Date Sampled	Matrix* See Key Below	Office Use Only Lab ID Number	Sampled by	Sample Description	Report Attention	Total and type of containers ** See below												
<u>7-9</u>	<u>S</u>	<u>BMI071196-01</u>		<u>PH2-MPB-4</u>		<u>1B</u>	<u>X</u>	<u>X</u>										
		<u>-02</u>		<u>PH2-MPS-5</u>		<u>1B</u>	<u>X</u>	<u>X</u>										
		<u>-03</u>		<u>PH2-MPS-8</u>		<u>1B</u>	<u>X</u>	<u>X</u>										
		<u>-04</u>		<u>PH2-MPS-9</u>		<u>1B</u>	<u>X</u>	<u>X</u>										
		<u>-05</u>		<u>PH2-MPS-10</u>		<u>1B</u>	<u>X</u>	<u>X</u>										
		<u>-06</u>		<u>PH2-MPS-15</u>		<u>1B</u>	<u>X</u>	<u>X</u>										
		<u>-07</u>		<u>PH2-MPS-17</u>		<u>1B</u>	<u>X</u>	<u>X</u>										
		<u>-08</u>		<u>PH2-MPS-19</u>		<u>1B</u>	<u>X</u>	<u>X</u>										
		<u>-09</u>		<u>PH2-MPII-8</u>		<u>1B</u>	<u>X</u>	<u>X</u>										
		<u>-10</u>		<u>PH2-MPII-9</u>		<u>1B</u>	<u>X</u>	<u>X</u>										
		<u>-11</u>		<u>PH2-MPII-11</u>		<u>1B</u>	<u>X</u>	<u>X</u>										
		<u>-12</u>		<u>PH2-MPII-15</u>		<u>1B</u>	<u>X</u>	<u>X</u>										

TPH and BIKE

MARKS:

Signature	Print Name	Company	Date	Time
_____	_____	_____	_____	_____
<u>Katherine Souza</u>	<u>Katherine Z Souza</u>	<u>PAI</u>	<u>7-11-96</u>	<u>1030</u>
_____	_____	_____	_____	_____
_____	_____	_____	_____	_____
_____	_____	_____	_____	_____

Samples are discarded 60 days after results are reported unless other arrangements are made. Hazardous samples will be returned to client or disposed of at client expense.

Billing Information:

Name _____
 Address _____
 City, State, Zip _____
 Phone Number _____ Fax _____



...phz ...lytr Inc.
 255 Glendale Avenue, Suite 21
 Sparks, Nevada 89431
 Phone (702) 355-1044
 Fax (702) 355-0406

Analyses Required

Client Name		P.O. #		Job #														
Address		PWS #		DWR #														
City, State, Zip		Phone #		Fax #														
Time Sampled	Date Sampled	Matrix* See Key Below	Office Use Only	Sampled by	Report Attention	Total and type of containers ** See below												
			Lab ID Number	Sample Description														
	7-10-96	SD	BMI071196-13	PH2-MP11-17		1B	X	X										
			-14	PH2-MP11-19		1B	X	X										
			-15	PH2-MP9-8		1B	X	X										
			-16	PH2-MP9-9		1B	X	X										
			-17	PH2-MP9-10		1B	X	X										
			-18	PH2-MP9-12		1B	X	X										
			-19	PH2-MP9-15		1B	X	X										
			-20	PH2-MP9-17		1B	X	X										
			-21	PH2-MP9-19		1B	X	X										
			-22	PH2-MP4-11		1B	X	X										
			-23	PH2-MP4-12		1B	X	X										
			-24	PH2-MP4-13		1B	X	X										

TPH etc
BIKE

REMARKS:

Signature	Print Name	Company	Date	Time
Relinquished by				
Received by <i>Katherine Z Segy</i>	<i>Katherine Z Segy</i>	<i>AAZ</i>	<i>7-11-96</i>	<i>1030</i>
Relinquished by				
Received by				
Relinquished by				
Received by				

NOTE: Samples are discarded 60 days after results are reported unless other arrangements are made. Hazardous samples will be returned to client or disposed of at client expense.
 CO - Soil WA - Waste OT - Other **: L-Liter V-Voa S-Soil Jar O-Orbo T-Tedlar B-Brass P-Plastic OT-Other

Name _____
 Address _____
 City, State, Zip _____
 Phone Number _____ Fax _____



255 Glendale Avenue, Suite 21
 Sparks, Nevada 89431
 Phone (702) 355-1044
 Fax (702) 355-0406

Analyses Required

Client Name		P.O. #		Job #													
Address		PWS #		DWR #													
City, State, Zip		Phone #		Fax #													
Time Sampled	Date Sampled	Matrix* See Key Below	Office Use Only Lab ID Number	Sampled by	Sample Description	Report Attention	Total and type of containers ** See below										
	7-10	SO	3M1071196-25		PH2-MPY-15		1B	X	X								
	↓	↓			-26 PH2-MPY-16		1B	X	X								
	↓	↓			-27 AR-MPY-17		1B	X	X								
	↓	↓			-28 PH2-MPY-19		1B	X	X								

TP-XXXX
 BTXE

REMARKS:

Signature	Print Name	Company	Date	Time
Relinquished by				
Received by <i>[Signature]</i>	<i>122 Souza</i>	<i>AAZP</i>	<i>7-11-96</i>	<i>1030</i>
Relinquished by				
Received by				
Relinquished by				
Received by				

NOTE: Samples are discarded 60 days after results are reported unless other arrangements are made. Hazardous samples will be returned to client or disposed of at client expense.
 *Key: AQ - Aqueous SO - Soil WA - Waste OT - Other **: L-Liter V-Voa S-Soil Jar O-Orbo T-Tedlar B-Brass P-Plastic OT-Other



Battelle

Columbus Laboratories

CHAIN OF CUSTODY RECORD

Form No. _____

Proj. No. 6002727-01	Project Title NEX Geo Station Port Hueneeme - Site 2	SAMPLE TYPE (✓)										Container No.	Number of Containers	Remarks					
SAMPLERS: (Signature) 		TPH-8015	BTEX-8240																

DATE	TIME	SAMPLE I.D.	TPH-8015	BTEX-8240																
7/9/96	0900	PH2-MP2-8	✓	✓																
7/9/96	0900	PH2-MP2-9	✓	✓																
	0910	PH2-MP2-11	✓	✓																
	0910	PH2-MP2-12	/	/																
	0910	PH2-MP2-13	/	/																
	0930	PH2-MP2-15	/	/																
	0930	PH2-MP2-17	/	/																
	0930	PH2-MP2-19	✓	✓																
7/9/96	1030	PH2-MP8-4	/	/																
	1030	PH2-MP8-5	/	/																
	1030	PH2-MP8-8	/	/																
7/9/96 CP	0900	PH2-MP2-10	/	/																
7/9/96	1050	PH2-MP8-11	/	/																
	1050	PH2-MP8-12	/	/																
	1050	PH2-MP8-17	/	/																

for all samples:
Remarks
Soil samples in
2 3/4 x 4"
aluminum tubes
w/ plastic end
caps, teflon
& 16-gauge tape
seals.

Relinquished by: (Signature) 	Date/Time 7/9/96 1600	Received by: (Signature) 	Relinquished by: (Signature)	Date/Time	Received by: (Signature)
Relinquished by: (Signature)	Date/Time	Received by: (Signature)	Relinquished by: (Signature)	Date/Time	Received by: (Signature)
Relinquished by: (Signature)	Date/Time	Received for Laboratory by: (Signature)	Date/Time	Remarks	

Name _____
 Address _____
 City, State, Zip _____
 Phone Number _____ Fax _____

Alpha Analytical, Inc.
 255 Glendale Avenue, Suite 21
 Sparks, Nevada 89431
 Phone (702) 355-1044
 Fax (702) 355-0406



Analyses Required

Client Name		P.O. #		Job #		<div style="display: flex; align-items: center;"> <div style="writing-mode: vertical-rl; transform: rotate(180deg); border: 1px solid black; padding: 5px;">TAH-8015</div> <div style="writing-mode: vertical-rl; transform: rotate(180deg); border: 1px solid black; padding: 5px;">BTX2</div> </div>														
Address		PWS #		DWR #																
City, State, Zip		Phone #		Fax #																
Time Sampled	Date Sampled	Matrix* See Key Below	Office Use Only	Sampled by	Report Attention	Total and type of containers** See below														
			Lab ID Number	Sample Description																
	7/9		BAI 071096-13	PH2 - MP8-11		16	X	X												
			-14	PH2 - MP8-12			X	X												
			-15	PH2 - MP8-17			X	X												
			-16	PH2 - MP6-4			X	X												
			-17	PH2 - MP6-5			X	X												
			-18	PH2 - MP6-7			X	X												
			-19	PH2 - MP6-8			X	X												
			-20	PH2 - MP6-9			X	X												
			-21	PH2 - MP6-10			X	X												
			-22	PH2 - MP6-15			X	X												
			-23	PH2 - MP6-17			X	X												
			-24	PH2 - MP6-79			X	X												

REMARKS:
 - MP8-5
 - MP8-8

Signature	Print Name	Company	Date	Time
Relinquished by				
Received by <i>Matherino Souza</i>	Matherino Souza	BAI	7-10-96	1000
Relinquished by				
Received by				
Relinquished by				
Received by				

NOTE: Samples are discarded 60 days after results are reported unless other arrangements are made. Hazardous samples will be returned to client or disposed of at client expense.
 *Key: AQ - Aqueous SO - Soil WA - Waste OT - Other **: L-Liter V-Voa S-Soil Jar O-Orbo T-Tedlar B-Brass P-Plastic OT-Other

Billing Information:

Name _____
 Address _____
 City, State, Zip _____
 Phone Number _____ Fax _____



Alpha Analytical, Inc.
 255 Glendale Avenue, Suite 21
 Sparks, Nevada 89431
 Phone (702) 355-1044
 Fax (702) 355-0406

Analyses Required

Client Name BATTELLE		PO. # G 002727-01	Job #
Address		PWS #	DWR #
City, State, Zip		Phone #	Fax #

Time Sampled	Date Sampled	Matrix* See Key Below	Office Use Only Lab ID Number	Sampled by	Report Attention	Sample Description	Total and type of containers ** See below	Analyses Required													
								TPH-8015	BTX												
	7/9	SO	BMI 071096-01			PH2 - MP2 - 8	1-B	X	X												
			-02			PH2 - MP2 - 9	1-B	X	X												
			-03			PH2 - MP2 - 10		X	X												
			-04			PH2 - MP2 - 11		X	X												
			-05			PH2 - MP2 - 12		X	X												
			-06			PH2 - MP2 - 13		X	X												
			-07			PH2 - MP2 - 15		X	X												
			-08			PH2 - MP2 - 17		X	X												
			-09			PH2 - MP2 - 19		X	X												
			-10			PH2 - MP8 - 4		X	X												
			-11			PH2 - MP8 - 5		X	X												
			-12			PH2 - MP8 - 8		X	X												

REMARKS:

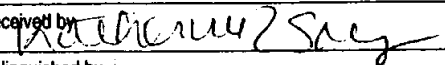
Signature	Print Name	Company	Date	Time
Relinquished by				
Received by 	Katherine Z Souza	PHI	7-10-96	1000
Relinquished by				
Received by				
Relinquished by				
Received by				

NOTE: Samples are discarded 60 days after results are reported unless other arrangements are made. Hazardous samples will be returned to client or disposed of at client expense.

APPENDIX C
SOIL BORING LOGS

To be provided under separate cover

APPENDIX D

SUMMARY OF FIELD ANALYSES OF CONTAMINANTS AND DISSOLVED OXYGEN

Table 2.1. Area concentration counts for monitoring point 1 (MP1).

Date	Location	Depth (ft BGS)	< Benzene (area)	Benzene- Toluene (area)	Toluene - Ethylbenzene (area)	Ethylbenzene - Xylene (area)	> Xylene (area)
9/1/96	MP1	10	57000	23000	11000	2600	3900
ASU	MP1	15	1300	530	70	51	190
	MP1	20	370	320	100	60	63
10/19/96	MP1	10	26000	14000	7000	2000	1800
ASU	MP1	15	350	400	0	13	0
	MP1	20	48	48	14	17	15
10/25/96	MP1	10	16000	9400	7300	18000	1200
ASU	MP1	15	3000	660	65	27	44
	MP1	20	590	400	52	24	13
AIS STARTUP 10/26/96							
10/28/96	MP1	10	27000	1800	360	92	73
ASU	MP1	15	260	300	340	68	45
	MP1	20	57	98	92	31	15
AVERAGE							
AVG* (pre AIS)	MP1	10	33000 ± 22000	16000 ± 6700	8300 ± 2000	2100 ± 400	2300 ± 1400
	MP1	15	1600 ± 1400	530 ± 130	45 ± 39	30 ± 19	78 ± 99
	MP1	20	330 ± 270	260 ± 180	55 ± 43	34 ± 23	30 ± 28

* This average is of the three sampling intervals prior to initiation of the *in situ* air sparging experiment.

Table 1.1. Concentrations of dissolved oxygen, benzene, toluene, ethylbenzene, and o-xylene for monitoring point 1 (MP1).

Date	Location	Depth (ft BGS)	DO (mg/L)	Benzene (µg/L)	Toluene (µg/L)	Ethylbenzene (µg/L)	O-Xylene (µg/L)
9/1/96 ALPHA*	MP1	10	<2	5100	13000	1400	7800
	MP1	15	<2	4	4	19	24
	MP1	20	<2	6	6	8	3
9/1/96 ASU**	MP1	10	<2	17000	37000	17000	7000
	MP1	15	<2	1000	750	120	140
	MP1	20	<2	200	550	140	170
10/19/96 ASU	MP1	10	<2	5900	17000	11000	4300
	MP1	15	<2	91	220	<15	28
	MP1	20	<2	15	62	22	36
10/25/96 ASU	MP1	10	<2	8400	30000	17000	9700
	MP1	15	<2	1400	2000	81	150
	MP1	20	<2	62	870	110	130
AIS STARTUP 10/26/96							
10/28/96 ASU	MP1	10	6.3	2300	2400	1700	820
	MP1	15	5.2	81	1200	1400	610
	MP1	20	<2	38	450	430	280
AVERAGE							
AVG*** (pre AIS)	MP1	10	<2	11000 ± 6000	28000 ± 970	15000 ± 3500	7000 ± 2704
	MP1	15	<2	830 ± 660	970 ± 890	67 ± 27	110 ± 67
	MP1	20	<2	92 ± 96	490 ± 410	90 ± 61	110 ± 67

* These samples were analyzed 9/10/96 by Alpha Analytical.

** These samples were measured in the field by ASU personnel using an SRI 8610 Gas Chromatograph.

*** This average is of the three sampling intervals prior to initiation of the *in situ* air sparging experiment.

Table 1.2. Concentrations of dissolved oxygen, benzene, toluene, ethylbenzene, and o-xylene for monitoring point 2 (MP2).

Date	Location	Depth (ft BGS)	DO (mg/L)	Benzene (µg/L)	Toluene (µg/L)	Ethylbenzene (µg/L)	O-Xylene (µg/L)
9/1/96 ASU	MP2	10	3	<15	<15	<15	<15
	MP2	11	<2	2300	1100	2100	580
	MP2	12	<2	1300	850	920	170
	MP2	13	<1	200	370	140	190
	MP2	14	3	140	310	55	75
	MP2	15	<2	1000	880	820	380
	MP2	16	<2	750	730	290	160
	MP2	17	3	120	140	78	170
	MP2	18	<2	16	200	79	180
	MP2	19	-	<15	24	44	77
10/19/96 ASU	MP2	10	<2	2551	1900	2600	270
	MP2	11	<2	1888	2500	3500	520
	MP2	12	<2	283	180	45	22
	MP2	13	<2	166	220	19	26
	MP2	14	<2	189	240	30	37
	MP2	15	<2	1572	600	150	48
	MP2	16	<2	1331	1300	85	0
	MP2	17	<2	156	270	33	25
	MP2	18	<2	57	114	40	28
	MP2	19	<2	19	53	22	0
10/25/96 ASU	MP2	10	<2	1100	160	660	26
	MP2	11	<2	900	380	500	43
	MP2	12	<2	280	190	6	6
	MP2	13	<2	76	110	11	10
	MP2	14	<2				
	MP2	15	<2	130	230	24	17
	MP2	16	<2	200	170	6	5
	MP2	17	<2				
	MP2	18	<2	13	95	42	19
	MP2	19	<2	39	160	120	30
AIS STARTUP 10/26/96							
10/27/96 ASU	MP2	10	<2	7400	3800	6300	420
	MP2	11	3	1100	430	1200	69
	MP2	12	5.8	40	160	100	33
	MP2	13	5.2	18	87	95	31
	MP2	14	7.7	14	62	62	25
	MP2	15	5.6	90	130	23	14
	MP2	16	3.7	110	160	23	14
	MP2	17	2.1	62	120	47	21
	MP2	18	6.6	7	33	35	14
	MP2	19	<2	6	19	22	8
AVERAGE							
AVG* (pre AIS)	MP2	10	<2	1200 ± 4000	680 ± 2100	1100 ± 3500	99 ± 240
	MP2	11	<2	930 ± 570	970 ± 240	1300 ± 590	190 ± 35
	MP2	12	<2	190 ± 150	120 ± 100	17 ± 57	9 ± 18
	MP2	13	<2	81 ± 40	110 ± 60	10 ± 51	12 ± 16
	MP2	14	<2	95 ± 10	80 ± 44	10 ± 44	12 ± 18

MP2	15	<2	570 ± 67	280 ± 120	59 ± 14	22 ± 9
MP2	16	<2	510 ± 100	500 ± 95	30 ± 12	2 ± 7
MP2	17	<2	78 ± 44	90 ± 87	11 ± 33	8 ± 15
MP2	18	<2	23 ± 7	70 ± 48	27 ± 23	16 ± 10
MP2	19	<2	19 ± 21	70 ± 87	46 ± 62	10 ± 16

* This average is of the three sampling intervals prior to initiation of the *in situ* air sparging experiment.

Table 2.2. Area concentration counts for monitoring point 2 (MP2).

Date	Location	Depth (ft BGS)	< Benzene (area)	Benzene- Toluene (area)	Toluene - Ethylbenzene (area)	Ethylbenzene - Xylene (area)	> Xylene (area)
9/1/96 ASU	MP2	10	<10	<10	<10	<10	<10
	MP2	11	22000	1800	1400	2100	2100
	MP2	12	7200	2000	580	56	1300
	MP2	13	540	480	80	63	270
	MP2	14	280	410	32	25	97
	MP2	15	3000	1700	590	130	1600
	MP2	16	1900	2000	190	54	1100
	MP2	17	270	81	45	55	62
	MP2	18	200	210	46	61	<10
	MP2	19	66	14	21	26	500
10/19/96 ASU	MP2	10	36000	2300	2500	160	1500
	MP2	11	43000	5500	4600	250	3300
	MP2	12	1500	210	38	<10	230
	MP2	13	1500	220	11	12	<10
	MP2	14	320	250	50	18	<10
	MP2	15	3000	590	200	380	1600
	MP2	16	3100	1300	230	210	1100
	MP2	17	300	250	21	12	<10
	MP2	18	190	150	25	12	<10
	MP2	19	170	41	14	<10	<10
10/25/96 ASU	MP2	10	14000	280	690	26	290
	MP2	11	14000	2000	930	43	600
	MP2	12	2200	630	35	16	190
	MP2	13	2400	140	11	10	<10
	MP2	15	430	490	42	17	96
	MP2	16	520	190	11	5	33
	MP2	18	230	150	54	19	21
	MP2	19	590	180	120	30	21
AIS STARTUP 10/26/96							
10/27/96 ASU	MP2	10	25000	2300	1300	47	570
	MP2	11	16000	1500	970	1200	1300
	MP2	12	1300	200	160	33	250
	MP2	13	850		120	31	79
	MP2	14	57	71	69	25	60
	MP2	15	360	310	54	14	170
	MP2	16	320	380	38	14	65
	MP2	17	180	140	65	21	49
	MP2	18	25	33	44	14	27
	MP2	19	320	19	28	8	7
AVERAGE							
AVG* (pre AIS)	MP2	10	17000 ± 8100	880 ± 1400	1000 ± 470	63 ± 15	610 ± 200
	MP2	11	26000 ± 4200	3100 ± 230	2300 ± 250	800 ± 1000	2000 ± 780
	MP2	12	3600 ± 3200	950 ± 940	220 ± 280	24 ± 20	570 ± 620
	MP2	13	1500 ± 1000	280 ± 240	34 ± 55	28 ± 27	
	MP2	14	200 ± 160	220 ± 240	27 ± 26	14 ± 0	32 ± 26

MP2	15	2200 ± 1500	920 ± 750	280 ± 310	180 ± 64	1100 ± 850
MP2	16	1800 ± 850	1100 ± 980	140 ± 94	89 ± 26	750 ± 610
MP2	17	190 ± 62	110 ± 41	22 ± 14	22 ± 24	21 ± 9
MP2	18	210 ± 110	170 ± 88	42 ± 5	31 ± 26	7 ± 4
MP2	19	280 ± 260	78 ± 94	50 ± 53	19 ± 12	170 ± 280

* This average is of the three sampling intervals prior to initiation of the *in situ* air sparging experiment.

Table 2.3. Area concentration counts for monitoring point 3 (MP3).

Date	Location	Depth (ft BGS)	< Benzene (area)	Benzene- Toluene (area)	Toluene - Ethylbenzene (area)	Ethylbenzene - Xylene (area)	> Xylene (area)
9/1/96 ASU	MP3	10	8700	300	1900	330	370
	MP3	11	31000	2900	12000	2700	2800
	MP3	12	12000	<100	<100	<100	<100
	MP3	13	4100	770	190	41	410
	MP3	14	790	180	88	65	<200
	MP3	15	38	110	96	47	110
	MP3	16	90	29	29	89	30
	MP3	17	240	69	92	230	62
	MP3	19	190	53	155	83	34
10/19/96 ASU	MP3	11	24000	3300	8000	1600	1800
	MP3	13	850	440	61	15	<10
	MP3	14	470	34	<10	<10	<10
	MP3	16	100	<10	<10	<10	<10
	MP3	17	46	<10	<10	<10	<10
	MP3	18	64	<10	10	<10	<10
	MP3	19	150	<10	<10	<10	<10
10/25/96 ASU	MP3	10	11000	260	860	81	1500
	MP3	11	15000	640	4800	890	660
	MP3	12	3000	50	6	<10	<10
	MP3	13	38	9	<10	9	6
	MP3	14	73	35	27	14	9
	MP3	15	25	45	21	7	<10
	MP3	16	26	8	7	8	6
	MP3	17	11	11	16	6	20
	MP3	18	38	38	25	9	29
MP3	19	54	42	30	12	23	
AIS STARTUP 10/26/96							
10/27/96 ASU	MP3	11	<10	<10	39	11	18
	MP3	12	<10	<10	<10	<10	<10
	MP3	13	48	14	<10	<10	<10
	MP3	14	<10	<10	<10	<10	<10
	MP3	15	61	41	56	18	29
	MP3	16	<10	<10	<10	<10	<10
	MP3	17	46	20	17	7	<10
	MP3	18	64	27	19	11	6
	MP3	19	571	178	187	33	39
AVERAGE							
AVG* (pre AIS)	MP3	10	9900 ± 1700	280 ± 34	1400 ± 750	200 ± 170	930 ± 790
	MP3	11	23000 ± 8000	2300 ± 1400	8300 ± 3600	1700 ± 930	1800 ± 1100
	MP3	12	5000 ± 6400	17 ± 35	<10	<10	<10
	MP3	13	1700 ± 2100	410 ± 380	84 ± 98	22 ± 17	140 ± 290
	MP3	14	440 ± 360	83 ± 84	38 ± 45	26 ± 34	<10
	MP3	15	31 ± 9	77 ± 45	59 ± 53	27 ± 28	55 ± 70
	MP3	16	79 ± 46	12 ± 15	12 ± 15	32 ± 49	12 ± 15

	MP3	17	100 ± 120	27 ± 37	36 ± 49	79 ± 130	27 ± 32
	MP3	18	140 ± 140	19 ± 27	18 ± 11	<10	29 ± 13
	MP3	19	130 ± 67	32 ± 28	62 ± 82	32 ± 45	19 ± 17

* This average is of the three sampling intervals prior to initiation of the *in situ* air sparging experiment.

Table 1.3. Concentrations of dissolved oxygen, benzene, toluene, ethylbenzene, and o-xylene for monitoring point 3 (MP3).

Date	Location	Depth (ft BGS)	DO (mg/L)	Benzene (µg/L)	Toluene (µg/L)	Ethylbenzene (µg/L)	O-Xylene (µg/L)
9/1/96 ASU	MP3	10	<2	870	250	2200	890
	MP3	11	<2	4900	2000	20000	7400
	MP3	12	<2	160	<200	<200	<200
	MP3	13	<2	1900	170	96	110
	MP3	14	<2	270	22	130	180
	MP3	15	<2	<15	110	80	220
	MP3	16	<2	19	57	49	190
	MP3	17	<2	34	110	160	270
	MP3	19	<2	<15	100	270	230
10/19/96 ASU	MP3	11	<2	2500	1400	12000	3300
	MP3	13	<2	220	200	97	32
	MP3	14	<2	28	31	<15	<15
	MP3	16	<2	<15	<15	<15	<15
	MP3	17	<2	<15	<15	<15	<15
	MP3	18	<2	<15	<15	18	<15
	MP3	19	<2	<15	<15	<15	<15
10/25/96 ASU	MP3	10	<2	720	450	1400	440
	MP3	11	<2	2500	630	14000	4900
	MP3	12	<2	48	140	18	<15
	MP3	13	<2	18	30	<15	33
	MP3	14	<2	48	91	42	49
	MP3	15	<2	18	101	63	38
	MP3	16	<2	18	27	21	44
	MP3	17	<2	14	37	27	60
	MP3	18	<2	48	128	75	49
	MP3	19	<2	55	142	57	66
AIS STARTUP 10/26/96							
10/28/96 ASU	MP3	11	<2	<15	<15	76	35
	MP3	12	<2	<15	<15	<15	<15
	MP3	13	<2	14	30	<15	<15
	MP3	14	<2	<15	13	<15	<15
	MP3	15	3.8	27	87	92	58
	MP3	16	<2	<15	<15	<15	<15
	MP3	17	4.2	23	42	33	23
	MP3	18	<2	39	57	37	35
	MP3	19	<2	287	367	365	106
AVERAGE							
AVG* (pre AIS)	MP3	10	<2	790 ± 100	350 ± 140	1800 ± 500	6700 ± 320
	MP3	11	<2	3300 ± 1400	1300 ± 690	16000 ± 4100	5200 ± 2100
	MP3	12	<2	100 ± 80	71 ± 100	9 ± 13	<15
	MP3	13	<2	700 ± 1000	130 ± 92	64 ± 56	59 ± 46
	MP3	14	<2	120 ± 130	48 ± 38	56 ± 64	76 ± 92
	MP3	15	<2	9 ± 13	51 ± 71	72 ± 12	130 ± 130
	MP3	16	<2	12 ± 1	28 ± 21	23 ± 20	79 ± 100

MP3	17	<2	16 ± 14	48 ± 49	61 ± 92	110 ± 140
MP3	18	<2	24 ± 34	64 ± 91	47 ± 41	25 ± 36
MP3	19	<2	18 ± 32	47 ± 82	110 ± 140	98 ± 120

* This average is of three sampling intervals prior to initiation of the *in situ* air sparging experiment.

Table 2.4. Area concentration counts for monitoring point 4 (MP4).

Date	Location	Depth (ft BGS)	< Benzene (area)	Benzene- Toluene (area)	Toluene - Ethylbenzene (area)	Ethylbenzene - Xylene (area)	> Xylene (area)
9/1/96 ASU	MP4	10	1400	540	120	310	150
	MP4	11	19000	960	390	<10	140
	MP4	15	640	73	55	40	<10
	MP4	20	620	16	48	36	<10
10/19/96 ASU	MP4	10	18000	3000	150	16	320
	MP4	15	470	280	120	33	11
	MP4	20	980	430	220	57	37
10/25/96 ASU	MP4	10	18000	510	97	32	98
	MP4	15	75	110	76	23	12
	MP4	20	250	420	210	50	30
AIS STARTUP 10/26/96							
10/27/96 ASU	MP4	10	28000	1900	240	54	92
	MP4	15	23	29	55	19	15
	MP4	20	45	22	16	9	16
AVERAGE							
AVG* (pre AIS)	MP4	10	18000 ± 560	1500 ± 1300	210 ± 160	120 ± 11	190 ± 120
	MP4	15	400 ± 290	160 ± 110	83 ± 32	32 ± 9	12 ± 1
	MP4	20	620 ± 370	290 ± 240	160 ± 98	48 ± 11	34 ± 5

* This average is of the three sampling intervals prior to initiation of the *in situ* air sparging experiment.

Table 1.4. Concentrations of dissolved oxygen, benzene, toluene, ethylbenzene, and o-xylene for monitoring point 4 (MP4).

Date	Location	Depth (ft BGS)	DO (mg/L)	Benzene ($\mu\text{g/L}$)	Toluene ($\mu\text{g/L}$)	Ethylbenzene ($\mu\text{g/L}$)	O-Xylene ($\mu\text{g/L}$)
9/1/96	MP4	10	<2	470	940	210	850
ASU	MP4	11	<2	980	810	670	<15
	MP4	15	<2	69	52	94	110
	MP4	20	<2	53	27	82	99
10/19/96	MP4	10	<2	630	720	61	34
ASU	MP4	15	<2	73	310	190	70
	MP4	20	<2	190	560	350	120
10/25/96	MP4	10	<2	1300	880	210	180
ASU	MP4	15	<2	64	380	230	130
	MP4	20	<2	270	1400	650	270
AIS STARTUP 10/26/96							
10/27/96	MP4	10	3	2900	2400	180	170
ASU	MP4	15	7	16	130	220	170
	MP4	20	<2	<15	100	83	80
AVERAGE							
AVG*	MP4	10	<2	970 \pm 330	800 \pm 83	310 \pm 320	350 \pm 100
(pre AIS)	MP4	15	<2	69 \pm 4	250 \pm 170	170 \pm 69	100 \pm 29
	MP4	20	<2	170 \pm 110	660 \pm 700	360 \pm 280	160 \pm 95

* This average is of the three sampling intervals prior to initiation of the *in situ* air sparging experiment.

Table 1.5. Concentrations of dissolved oxygen, benzene, toluene, ethylbenzene, and o-xylene for monitoring point 5 (MP5).

Date	Location	Depth (ft BGS)	DO (mg/L)	Benzene (µg/L)	Toluene (µg/L)	Ethylbenzene (µg/L)	O-Xylene (µg/L)
9/1/96 ASU	MP5	10	<2	7200	17000	9800	4200
	MP5	20	<2	190	360	190	240
10/19/96 ASU	MP5	10	<2	5500	15000	14000	4400
	MP5	15	<2	300	230	25	34
	MP5	20	<2	33	59	84	40
10/25/96 ASU	MP5	10	<2	17000	42000	24000	9300
	MP5	15	<2	28	71	27	33
	MP5	20	<2	<15	20	39	<15
AIS STARTUP 10/26/96							
10/27/96 ASU	MP5	10	2.8	4400	13000	6200	2800
	MP5	15	4.5	51	210	120	71
	MP5	20	<2	370	1200	350	190
AVERAGE							
AVG* (pre AIS)	MP5	10	<2	10000 ± 6500	25000 ± 16000	16000 ± 7600	6000 ± 2900
	MP5	15	<2	170 ± 190	150 ± 110	26 ± 1	33 ± 1
	MP5	20	<2	73 ± 110	150 ± 180	100 ± 76	94 ± 140

* This average is of the three sampling intervals prior to initiation of the *in situ* air sparging experiment.

Table 2.5. Area concentration counts for monitoring point 5 (MP5).

Date	Location	Depth (ft BGS)	< Benzene (area)	Benzene- Toluene (area)	Toluene - Ethylbenzene (area)	Ethylbenzene - Xylene (area)	> Xylene (area)
9/1/96	MP5	10	10000	11000	5900	1500	2300
ASU	MP5	20	130	210	110	89	45
10/19/96	MP5	10	30000	13000	9000	2100	3300
ASU	MP5	15	1400	500	15	16	32
	MP5	20	880	46	53	19	<10
10/25/96	MP5	10	43000	18000	8400	1700	2400
ASU	MP5	15	140	21	9	6	<10
	MP5	20	130	6	10	<10	<10
AIS STARTUP 10/26/96							
10/27/96	MP5	10	9000	6200	3800	870	590
ASU	MP5	15	49	101	61	22	6
	MP5	20	440	568	190	60	22
AVERAGE							
AVG	MP5	10	28000 ± 17000	14000 ± 3700	7800 ± 1600	1800 ± 280	2700 ± 570
(pre AIS)	MP5	15	750 ± 860	260 ± 340	12 ± 4	36 ± 50	16 ± 23
	MP5	20	380 ± 430	86 ± 110	58 ± 50	48 ± 11	15 ± 32

* This average is of the three sampling intervals prior to initiation of the *in situ* air sparging experiment.

Table 1.6. Concentrations of dissolved oxygen, benzene, toluene, ethylbenzene, and o-xylene for monitoring point 6 (MP6).

Date	Location	Depth (ft BGS)	DO (mg/L)	Benzene (µg/L)	Toluene (µg/L)	Ethylbenzene (µg/L)	O-Xylene (µg/L)
9/1/96 ASU	MP6	10	<2	8400	11000	11000	4800
	MP6	15	<2	36	56	31	83
	MP6	20	<2	17	20	59	62
10/19/96 ASU	MP6	10	<2	3600	5800	5800	1900
	MP6	15	<2	<15	<15	<15	<15
	MP6	20	<2	12	17	<15	28
AIS STARTUP 10/26/96							
10/28/96 ASU	MP6	10	6.7	2300	8300	8830	4700
	MP6	15	6.4	35	140	310	130
	MP6	20	6.9	14	85	130	90
AVERAGE							
AVG* (pre AIS)	MP6	10	<2	6000 ± 3300	8600 ± 3900	8300 ± 3500	3300 ± 2100
	MP6	15	<2	35 ± 24	28 ± 40	16 ± 21	42 ± 58
	MP6	20	<2	15 ± 4	19 ± 2	30 ± 41	45 ± 24

* This average is of the two sampling intervals prior to initiation of the *in situ* air sparging experiment.

Table 2.6. Area concentration counts for monitoring point 6 (MP6).

Date	Location	Depth (ft BGS)	< Benzene (area)	Benzene- Toluene (area)	Toluene - Ethylbenzene (area)	Ethylbenzene - Xylene (area)	> Xylene (area)
9/1/96	MP6	10	27000	6900	6300	1800	2000
ASU	MP6	15	120	32	18	30	35
	MP6	20	72	12	35	23	36
	MP6	10	21000	6000	3700	880	1200
10/9/96	MP6	15	80	<10	<10	<10	<10
ASU	MP6	20	32	13	<10	13	<10
	MP6	10	3100	3900	4500	1500	1500
	MP6	15	40	64	160	41	98
AIS STARTUP 10/26/96	MP6	20	58	65	28	31	55
	MP6	10	24000 ± 4500	6400 ± 600	5000 ± 1800	1300 ± 620	1600 ± 580
	MP6	15	100 ± 31	16 ± 23	<10	15 ± 20	18 ± 24
AVERAGE	MP6	20	52 ± 28	13 ± 1	18 ± 25	18 ± 7	18 ± 25
	MP6	15	100 ± 31	16 ± 23	<10	15 ± 20	18 ± 24
	MP6	20	52 ± 28	13 ± 1	18 ± 25	18 ± 7	18 ± 25
AVG (pre AIS)	MP6	10	24000 ± 4500	6400 ± 600	5000 ± 1800	1300 ± 620	1600 ± 580
	MP6	15	100 ± 31	16 ± 23	<10	15 ± 20	18 ± 24
	MP6	20	52 ± 28	13 ± 1	18 ± 25	18 ± 7	18 ± 25

* This average is of the two sampling intervals prior to initiation of the *in situ* air sparging experiment.

Table 1.7. Concentrations of dissolved oxygen, benzene, toluene, ethylbenzene, and o-xylene for monitoring point 7 (MP7).

Date	Location	Depth (ft BGS)	DO (mg/L)	Benzene (µg/L)	Toluene (µg/L)	Ethylbenzene (µg/L)	O-Xylene (µg/L)
9/1/96	MP7	15	<2	2.4	5.4	66	47
ALPHA*	MP7	20	<2	9.2	24	45	110
9/1/96	MP7	15	<2	85	460	210	220
ASU**	MP7	20	<2	170	710	510	310
10/19/96	MP7	10	<2	110	410	91	59
ASU	MP7	15	<2	150	220	61	36
AIS STARTUP 10/26/96							
10/27/96	MP7	10	<2	23000	43000	20000	7700
ASU	MP7	15	<2	540	720	100	80
	MP7	20	<2	790	1100	47	71
AVERAGE							
AVG**	MP7	10	<2	110	410	91	59
(pre AIS)	MP7	15	<2	120 ± 49	340 ± 180	130 ± 100	130 ± 130
	MP7	20	<2	170	710	510	310

* These samples were analyzed 9/10/96 by Alpha Analytical.

** These samples were analyzed by ASU personnel using an SRI 8610 Gas Chromatograph

*** This average is of the two sampling intervals prior to initiation of the *in situ* air sparging experiment.

Table 2.7. Area concentration counts for monitoring point 7 (MP7).

Date	Location	Depth (ft BGS)	< Benzene (area)	Benzene- Toluene (area)	Toluene - Ethylbenzene (area)	Ethylbenzene- Xylene (area)	> Xylene (area)
9/1/96	MP7	15	410	360	230	73	870
ASU	MP7	20	510	530	320	100	830
10/19/96	MP7	10	1100	540	85	27	160
ASU	MP7	15	450	320	57	17	160
AIS STARTUP 10/26/96							
10/27/96	MP7	10	34000	10000	3900	870	730
ASU	MP7	15	610	50	9	95	45
	MP7	20	640	550	31	8	70
AVERAGE							
AVG*	MP7	10	1100	540	85	27	160
(pre AIS)	MP7	15	430 ± 24	340 ± 27	150 ± 120	50 ± 40	510 ± 500
	MP7	20	510	530	320	100	830

* This average is of the two sampling intervals prior to initiation of the *in situ* air sparging experiment.

Table 1.8. Concentrations of dissolved oxygen, benzene, toluene, ethylbenzene, and o-xylene for monitoring point 8 (MP8).

Date	Location	Depth (ft BGS)	DO (mg/L)	Benzene (µg/L)	Toluene (µg/L)	Ethylbenzene (µg/L)	O-Xylene (µg/L)
9/1/96 ASU	MP8	10	<2	360	<15	<15	<15
	MP8	15	<2	16	<15	<15	<15
	MP8	20	<2	15	39	110	140
10/19/96 ASU	MP8	10	<2	450	120	410	59
	MP8	15	<2	87	180	75	36
	MP8	20	<2	500	800	240	100
AIS STARTUP 10/26/96							
10/27/96 ASU	MP8	10	<2	65	64	36	71
	MP8	15	<2	<15	110	94	<15
	MP8	20	2.6	26	160	73	54
AVERAGE							
AVG (pre AIS)	MP8	10	<2	400 ± 69	68 ± 74	210 ± 280	37 ± 31
	MP8	15	<2	52 ± 50	100 ± 120	45 ± 43	26 ± 15
	MP8	20	<2	260 ± 340	420 ± 540	180 ± 90	120 ± 30

* This average is of the two sampling intervals prior to initiation of the *in situ* air sparging experiment.

Table 2.8. Area concentration counts for monitoring point 8 (MP8).

Date	Location	Depth (ft BGS)	< Benzene (area)	Benzene- Toluene (area)	Toluene - Ethylbenzene (area)	Ethylbenzene - Xylene (area)	> Xylene (area)
9/1/96 ASU	MP8	10	2500	<10	<10	<10	<10
	MP8	15	20	<10	<10	<10	<10
	MP8	20	50	22	67	52	<10
10/19/96 ASU	MP8	10	26000	280	270	28	130
	MP8	15	98	143	47	17	<10
	MP8	20	1100	620	150	47	12
AIS STARTUP 10/26/96							
10/27/96 ASU	MP8	10	13000	14	7	7	<10
	MP8	15	24	18	9	<10	<10
	MP8	20	45	36	14	6	<10
AVERAGE							
AVG* (pre AIS)	MP8	10	14000 ± 17000	140 ± 190	140 ± 190	19 ± 13	72 ± 88
	MP8	15	59 ± 55	77 ± 94	29 ± 26	14 ± 5	<10
	MP8	20	560 ± 720	320 ± 420	110 ± 59	50 ± 4	<10

* This average is of the two sampling intervals prior to initiation of the *in situ* air sparging experiment.

Table 1.9. Concentrations of dissolved oxygen, benzene, toluene, ethylbenzene, and o-xylene for monitoring point 9 (MP9).

Date	Location	Depth (ft BGS)	DO (mg/L)	Benzene (µg/L)	Toluene (µg/L)	Ethylbenzene (µg/L)	O-Xylene (µg/L)
9/1/96 ASU	MP9	10	<2	1600	230	1600	210
	MP9	11	<2	4200	750	1800	1500
	MP9	12	<2	700	210	34	79
	MP9	13	<2	37	70	61	110
	MP9	14	<2	29	65	110	190
	MP9	15	<2	58	85	130	190
	MP9	16	<2	18	49	82	140
	MP9	17	<2	<15	30	53	92
	MP9	18	<2	32	74	120	200
10/19/96 ASU	MP9	10	<2	140	110	70	<10
	MP9	11	<2	1700	490	260	79
	MP9	12	<2	550	330	16	<15
	MP9	13	<2	19	31	<15	<15
	MP9	14	<2	<15	14	<15	<15
	MP9	15	<2	<15	<15	<15	<15
	MP9	16	<2	<15	18	<15	<15
	MP9	17	<2	13	21	<15	<15
	MP9	19	<2	26	63	24	30
AIS STARTUP 10/26/96							
10/28/96 ASU	MP9	10	<2	1000	1400	520	200
	MP9	12	4.2	14	66	100	39
	MP9	13	3.8	21	150	150	58
	MP9	14	<2	<15	15	23	<15
	MP9	15	<2	48	330	380	130
	MP9	16	<2	28	170	160	55
	MP9	17	2.3	35	270	230	87
	MP9	18	<2	34	220	170	68
	MP9	19	4.1	290	2200	1200	390
AVERAGE							
AVG* (pre AIS)	MP9	10	<2	850 ± 1000	170 ± 82	860 ± 1100	100 ± 150
	MP9	11	<2	2900 ± 1800	620 ± 180	1000 ± 1100	770 ± 980
	MP9	12	<2	620 ± 110	270 ± 86	25 ± 13	40 ± 56
	MP9	13	<2	39 ± 13	51 ± 28	30 ± 43	54 ± 76
	MP9	14	<2	28 ± 21	40 ± 36	57 ± 81	95 ± 134
	MP9	15	<2	29 ± 41	43 ± 60	65 ± 92	95 ± 134
	MP9	16	<2	<15	34 ± 22	41 ± 58	69 ± 97
	MP9	17	<2	<15	26 ± 6	27 ± 37	46 ± 65
	MP9	18	<2	23	37	60 ± 87	100 ± 140
MP9	19	<2	22 ± 6	84 ± 29	46 ± 88	110 ± 120	

* This average is of the two sampling intervals prior to initiation of the *in situ* air sparging experiment.

Table 2.9. Area concentration counts for monitoring point 9 (MP9).

Date	Location	Depth (ft. BGS)	< Benzene (area)	Benzene- Toluene (area)	Toluene - Ethylbenzene (area)	Ethylbenzene - Xylene (area)	> Xylene (area)
9/1/96 ASU	MP9	10	17000	370	990	75	300
	MP9	11	25000	1800	1200	2800	1800
	MP9	12	1400	600	64	29	98
	MP9	13	140	40	36	40	<10
	MP9	14	170	37	67	70	<10
	MP9	15	230	49	76	69	<10
	MP9	16	170	28	48	50	<10
	MP9	17	140	17	31	34	<10
	MP9	18	170	43	72	73	<10
	MP9	19	170	92	87	73	<10
10/19/96 ASU	MP9	10	11000	98	130	<10	<10
	MP9	11	15000	2600	450	34	390
	MP9	12	1400	730	35	<10	<10
	MP9	13	94	17	24	<10	<10
	MP9	14	90	11	<10	<10	<10
	MP9	15	110	<10	<10	<10	<10
	MP9	16	130	14	<10	<10	<10
	MP9	17	110	17	<10	<10	<10
	MP9	19	170	72	33	14	14
AIS STARTUP 10/26/96							
10/28/96 ASU	MP9	10	26000	760	600	62	190
	MP9	12	36	31	51	12	21
	MP9	13	76	76	79	18	21
	MP9	14	15	7	12	<10	<10
	MP9	15	540	160	190	39	45
	MP9	16	220	87	80	17	24
	MP9	17	52	130	120	27	25
	MP9	18	79	110	88	21	19
	MP9	19	290	1000	640	120	91
	AVERAGE						
AVG (pre AIS)	MP9	10	14000 ± 4400	240 ± 200	560 ± 600	63 ± 53	610 ± 210
	MP9	11	20000 ± 6800	2200 ± 580	840 ± 560	1400 ± 1900	1100 ± 980
	MP9	12	1400 ± 33	670 ± 91	50 ± 280	15 ± 20	<10
	MP9	13	120 ± 32	29 ± 16	34 ± 55	20 ± 27	<10
	MP9	14	130 ± 56	24 ± 18	27 ± 26	35 ± 49	<10
	MP9	15	170 ± 90	25 ± 35	280 ± 310	35 ± 49	<10
	MP9	16	150 ± 27	21 ± 10	140 ± 94	25 ± 35	<10
	MP9	17	120 ± 21	17 ±	22 ± 14	17 ± 24	<10
	MP9	18	210 ± 120	43	42 ± 51	37 ± 52	<10
	MP9	19	170 ± 4	82 ± 14	60 ± 53	44 ± 42	<10

* This average is of the two sampling intervals prior to initiation of the *in situ* air sparging experiment.

Table 1.10. Concentrations of dissolved oxygen, benzene, toluene, ethylbenzene, and o-xylene for monitoring point 10 (MP10).

Date	Location	Depth (ft BGS)	DO (mg/L)	Benzene ($\mu\text{g/L}$)	Toluene ($\mu\text{g/L}$)	Ethylbenzene ($\mu\text{g/L}$)	O-Xylene ($\mu\text{g/L}$)
9/1/96 ALPHA*	MP10	10	<2	1500	27	1800	2000
	MP10	15	<2	<0.5	<0.5	<0.5	<0.5
	MP10	20	<2	0.56	0.94	0.68	0.75
9/1/96 ASU**	MP10	10	<2	1700	300	4200	840
	MP10	15	<2	16	220	110	140
	MP10	20	<2	570	1900	870	390
10/19/96 ASU	MP10	10	<2	390	150	800	95
	MP10	15	<2	43	130	70	36
	MP10	20	<2	62	140	120	49
AIS STARTUP 10/26/96							
10/27/96 ASU	MP10	10	<2	540	91	510	100
	MP10	15	<2	81	180	68	98
	MP10	20	<2	<15	91	26	89
AVERAGE							
AVG*** (pre AIS)	MP10	10	<2	1100 \pm 940	230 \pm 110	2500 \pm 2400	470 \pm 520
	MP10	15	<2	30 \pm 19	180 \pm 66	89 \pm 26	90 \pm 76
	MP10	20	<2	320 \pm 360	1000 \pm 1300	500 \pm 530	220 \pm 240

* These samples were analyzed 9/10/96 by Alpha Analytical.

** These samples were analyzed by ASU personnel in the field using an SRI 8610 Gas Chromatograph.

*** This average is of the two sampling intervals prior to initiation of the *in situ* air sparging experiment.

Table 2.10. Area concentration counts for monitoring point 10 (MP10).

Date	Location	Depth (ft BGS)	< Benzene (area)	Benzene- Toluene (area)	Toluene - Ethylbenzene (area)	Ethylbenzene - Xylene (area)	> Xylene (area)
9/1/96	MP10	10	20000	200	2500	310	1000
ASU	MP10	15	800	180	63	53	170
	MP10	20	1500	1100	510	140	92
10/19/96	MP10	10	14000	140	1100	45	490
ASU	MP10	15	570	110	44	17	58
	MP10	20	850	100	75	23	<10
AIS STARTUP 10/26/96							
10/27/96	MP10	10	11000	120	75	31	84
ASU	MP10	15	270	46	13	11	16
	MP10	20	34	20	21	10	17
AVERAGE							
AVG	MP10	10	17000 ± 4200	170 ± 40	1800 ± 950	180 ± 180	760 ± 380
(pre AIS)	MP10	15	690 ± 160	150 ± 49	54 ± 13	35 ± 25	110 ± 78
	MP10	20	1200 ± 460	610 ± 720	290 ± 310	84 ± 85	46 ± 65

* This average is of the two sampling intervals prior to initiation of the *in situ* air sparging experiment.

Table 2.11. Area concentration counts for monitoring point 11 (MP11).

Date	Location	Depth (ft BGS)	< Benzene (area)	Benzene- Toluene (area)	Toluene - Ethylbenzene (area)	Ethylbenzene - Xylene (area)	> Xylene (area)
10/19/96	MP11	10	55	11	17	<10	<10
ASU	MP11	15	98	12	59	15	13
	MP11	20	2148	23	<10	<10	<10
AIS STARTUP 10/26/96							
10/27/96	MP11	10	39000	14985	10808	2036	2511
ASU	MP11	15	51	38	23	12	<10
	MP11	20	38	83	43	17	<10

Table 2.12. Area concentration counts for monitoring point 12 (MP12).

Date	Location	Depth (ft BGS)	< Benzene (area)	Benzene- Toluene (area)	Toluene - Ethylbenzene (area)	Ethylbenzene - Xylene (area)	> Xylene (area)
10/19/96	MP12	10	22000	8300	4500	1000	1100
	MP12	20	27	<10	<10	<10	<10
AIS STARTUP 10/26/96							
10/27/96	MP12	10	2000	4600	740	25	22
ASU	MP12	15	400	230	370	130	100
	MP12	20	59	19	17	7	<10

Table 1.11. Concentrations of dissolved oxygen, benzene, toluene, ethylbenzene, and o-xylene for monitoring point 11 (MP11).

Date	Location	Depth (ft BGS)	DO (mg/L)	Benzene (µg/L)	Toluene (µg/L)	Ethylbenzene (µg/L)	O-Xylene (µg/L)
10/19/96 ASU	MP11	10	<2	<15	18	26	<15
	MP11	15	<2	<15	20	90	36
	MP11	20	<2	18	38	<15	<15
AIS STARTUP 10/26/96							
10/27/96 ASU	MP11	10	<2	29000	64000	33000	18000
	MP11	15	<2	35	170	120	110
	MP11	20	<2	84	380	200	150

Table 1.12. Concentrations of dissolved oxygen, benzene, toluene, ethylbenzene, and o-xylene for monitoring point 12 (MP12).

Date	Location	Depth (ft BGS)	DO (mg/L)	Benzene (µg/L)	Toluene (µg/L)	Ethylbenzene (µg/L)	O-Xylene (µg/L)
10/19/96	MP12	10	<2	7500	12000	6600	2500
	MP12	20	<2	<15	<15	<15	<15
AIS STARTUP 10/26/96							
10/28/96	MP12	10	<2	2200	4600	55	71
ASU	MP12	15	<2	590	480	730	410
	MP12	20	<2	<15	40	33	23

Monitoring Well BTEX Concentrations

Location	Date	DO (mg/L)	Benzene (µg/L)	Toluene (µg/L)	Ethylbenzene (µg/L)	Xylene (µg/L)
MW1	10/27/96	<2	330	550	210	260
	10/28/96	<2	<15	38	51	20
MW2	10/19/96	<2	48	100	86	38
	10/25/96	<2	<15	<15	<15	<15
	10/26/96	<2	<15	<15	<15	<15
	10/27/96	<2	180	240	300	140
	10/28/96	<2	27	76	55	32
MW3	10/19/96	<2	170	330	100	67
	10/25/96	<2	310	1100	660	280
	10/28/96	<2	34	100	84	64
MW4	10/25/96	<2	<15	47	57	44
	10/27/96	<2	1200	1100	530	360
MW5	10/25/96	<2	37	250	290	140
	10/26/96	<2	1600	850	1000	1900
	10/27/96	<2	440	340	140	210
MW6	10/25/96	<2	670	2400	110	3600
	10/27/96	<2	silted up			

Headspace measurements of groundwater samples were made with a Series 9300 Gas Chromatograph (SRI Instruments, Torrance, California). The following chromatograms are representative of the general molecular weight distributions seen at intervals of 10, 15, and 20 feet below ground surface.

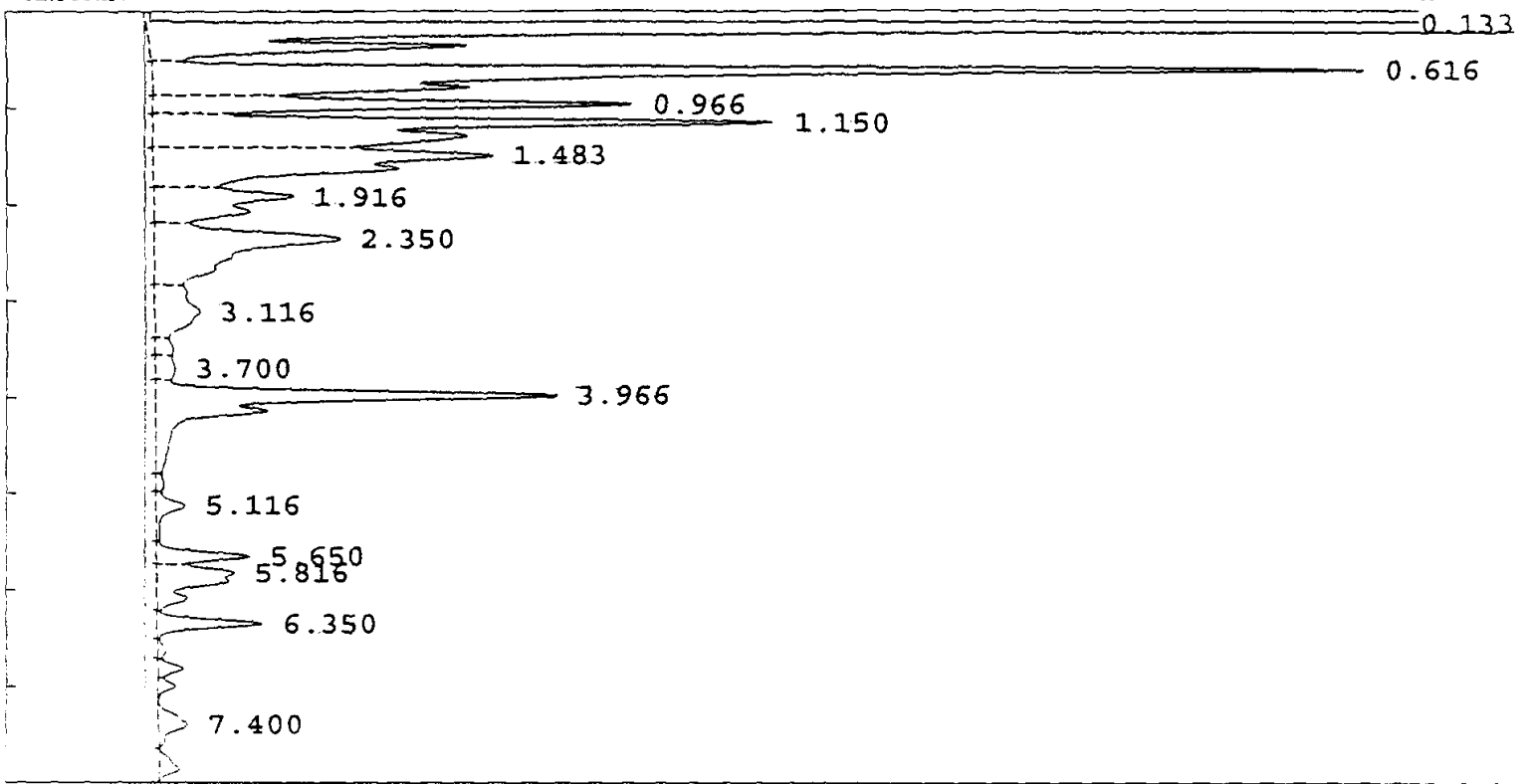

1.483, 1.916, 2.350, 3.116, 3.700, 3.966, 5.116, 5.650, 5.816, 6.350, 7.400
Chromatogram

Chromatogram from a 10' well-port

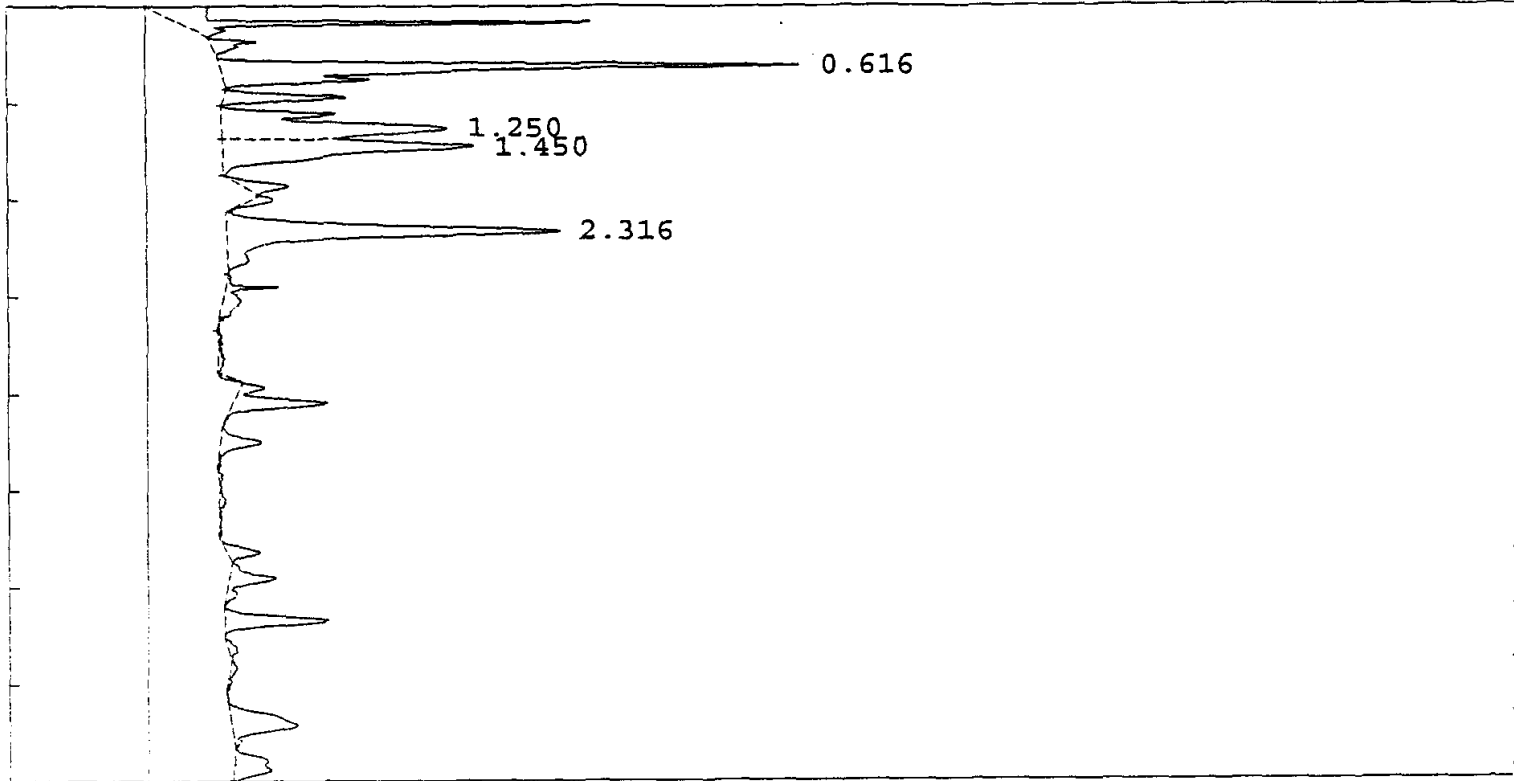

-1.955mV

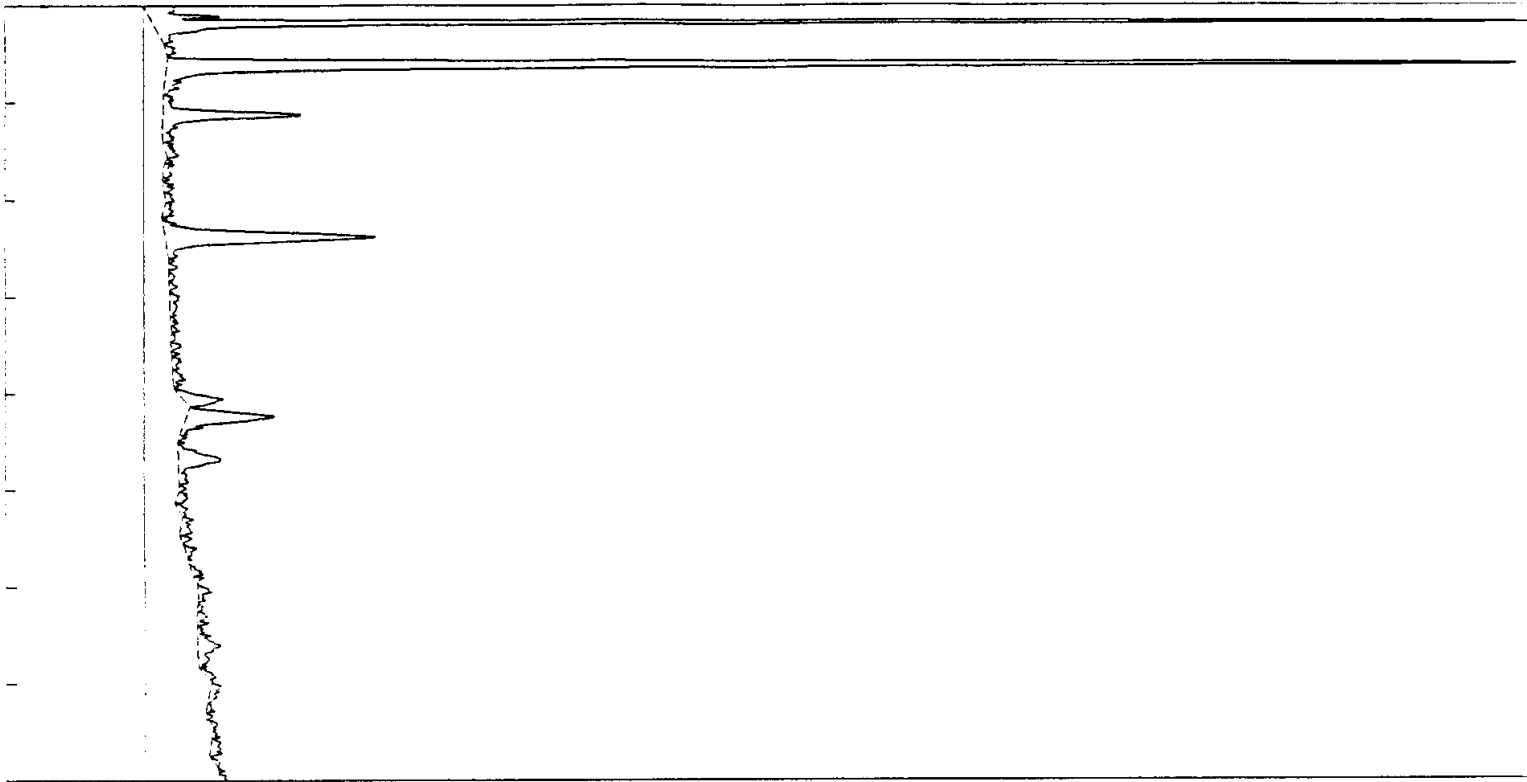

Sample chromatograms for a 20' port

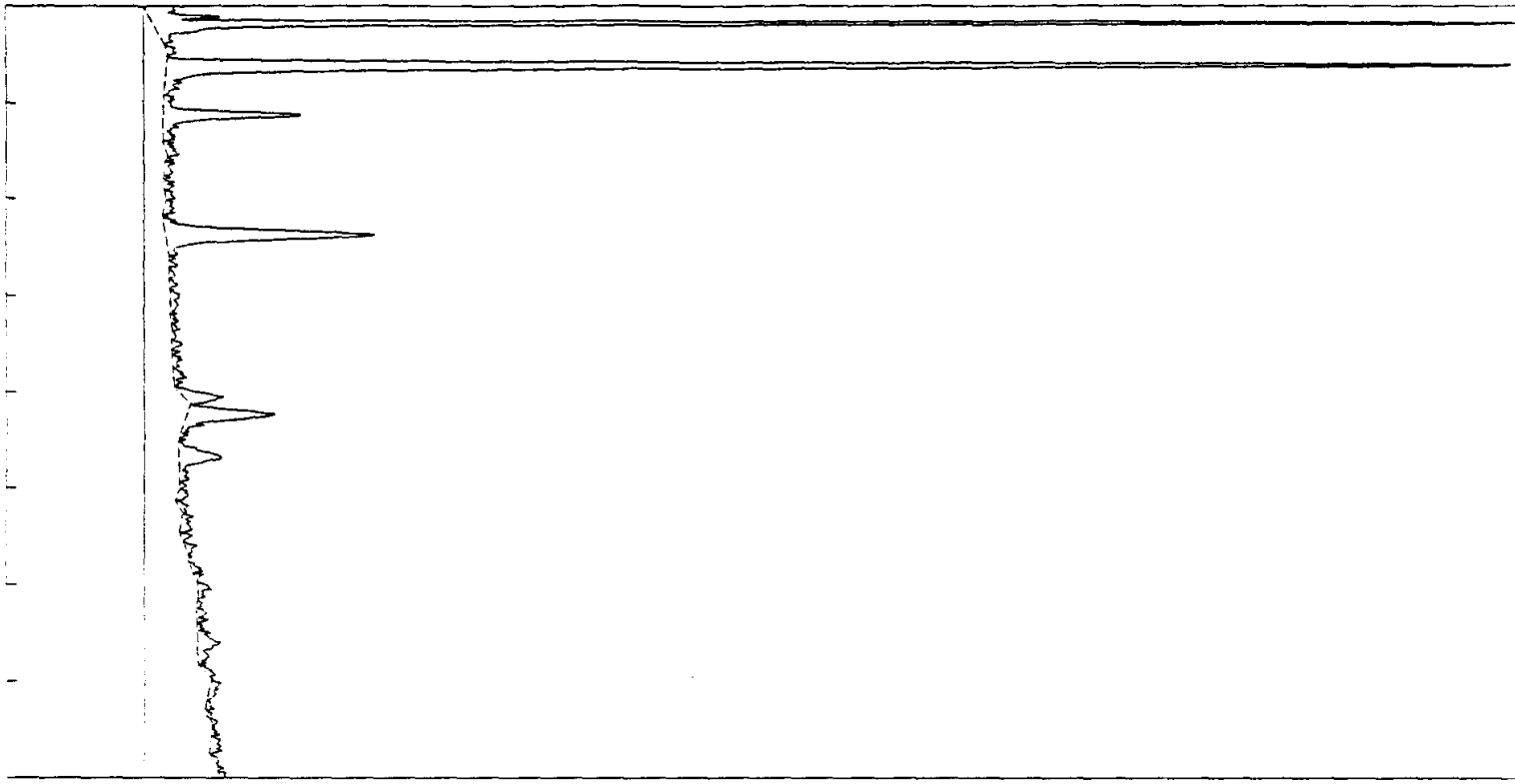

Typical chromatograms for a 20' port

APPENDIX E

SUMMARY OF PULSED SF₆ INJECTION STUDIES

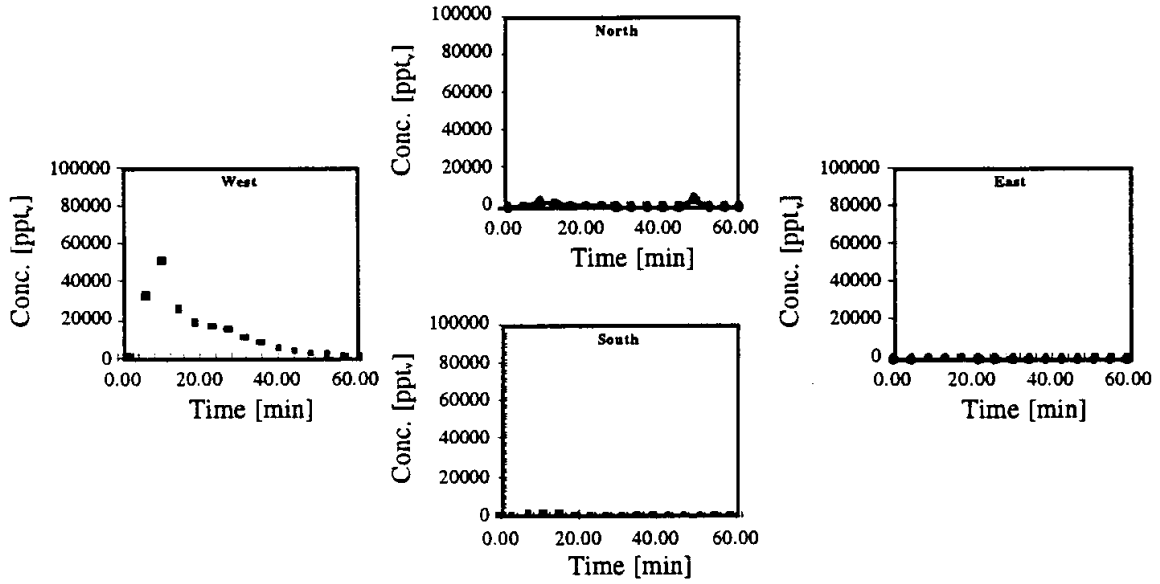

Figure SF-1. Directional soil vapor extraction well response to 0.5 mL injection of SF₆ into MP-1 (4-ft below ground surface); vapor extraction system only; flow per well 8 - 10 ft³/min (9/7/96).

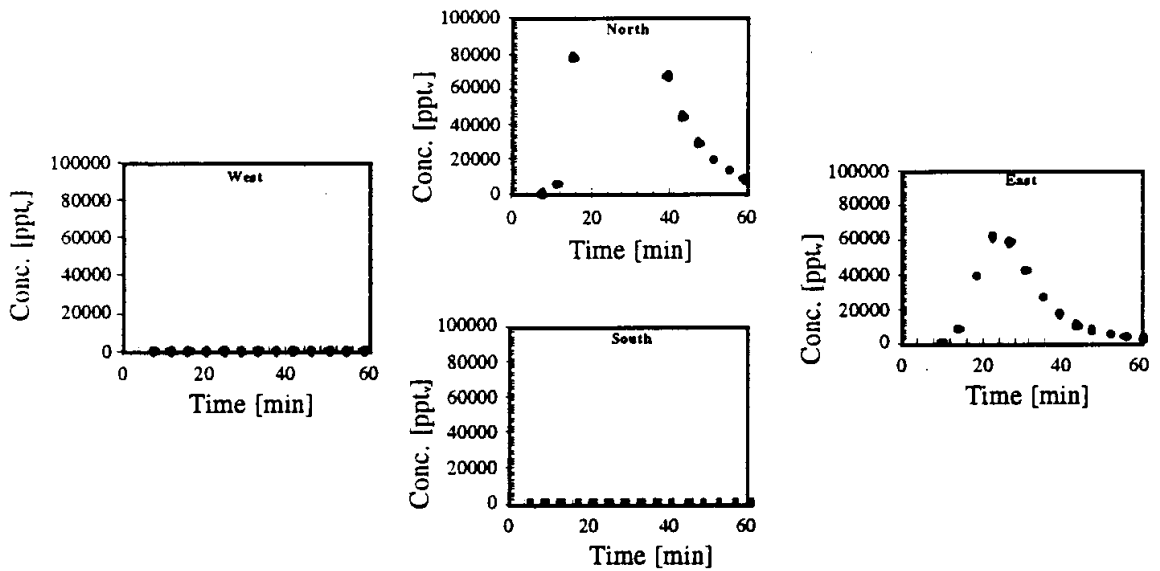

Figure SF-2. Directional soil vapor extraction well response to 1.0 mL injection of SF₆ into MP-2 (4-ft below ground surface); vapor extraction system only; flow per well 8 - 10 ft³/min (9/7/96).

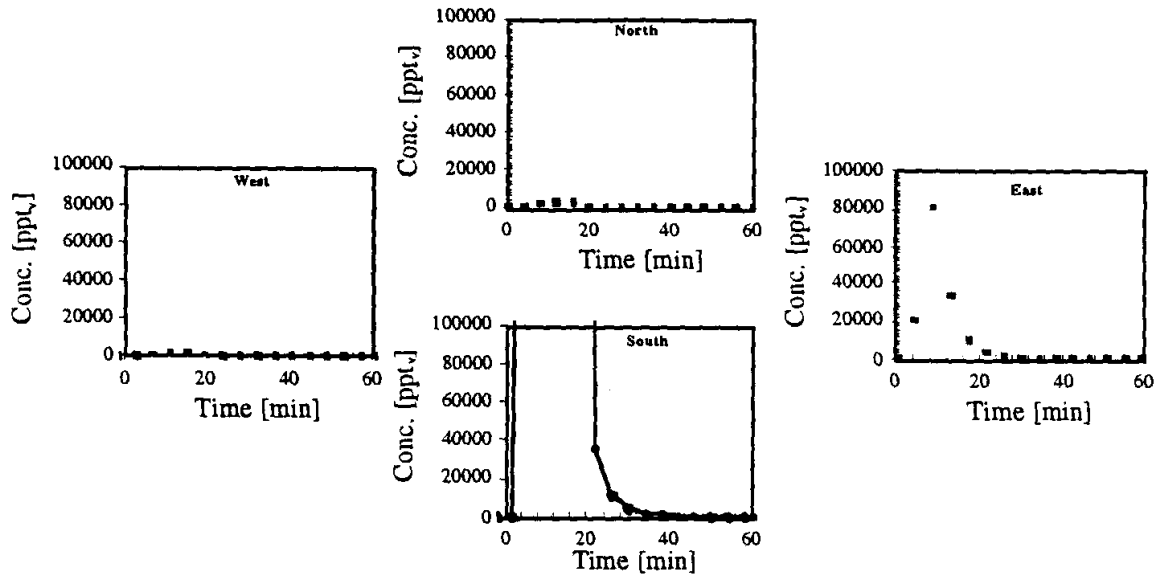

Figure SF-3. Directional soil vapor extraction well response to 0.5 mL injection of SF₆ into MP-3 (4-ft below ground surface); vapor extraction system only; flow per well 8 - 10 ft³/min (9/7/96).

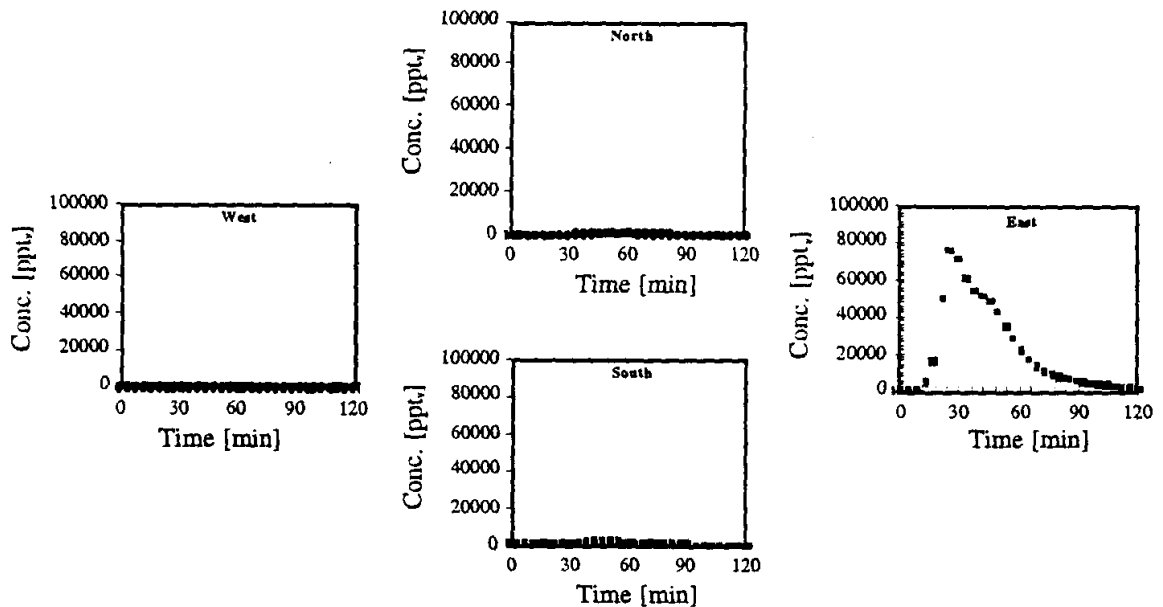

Figure SF-4. Directional soil vapor extraction well response to 0.5 mL injection of SF₆ into MP-4 (4-ft below ground surface); vapor extraction system only; flow per well 8 - 10 ft³/min (9/8/96).

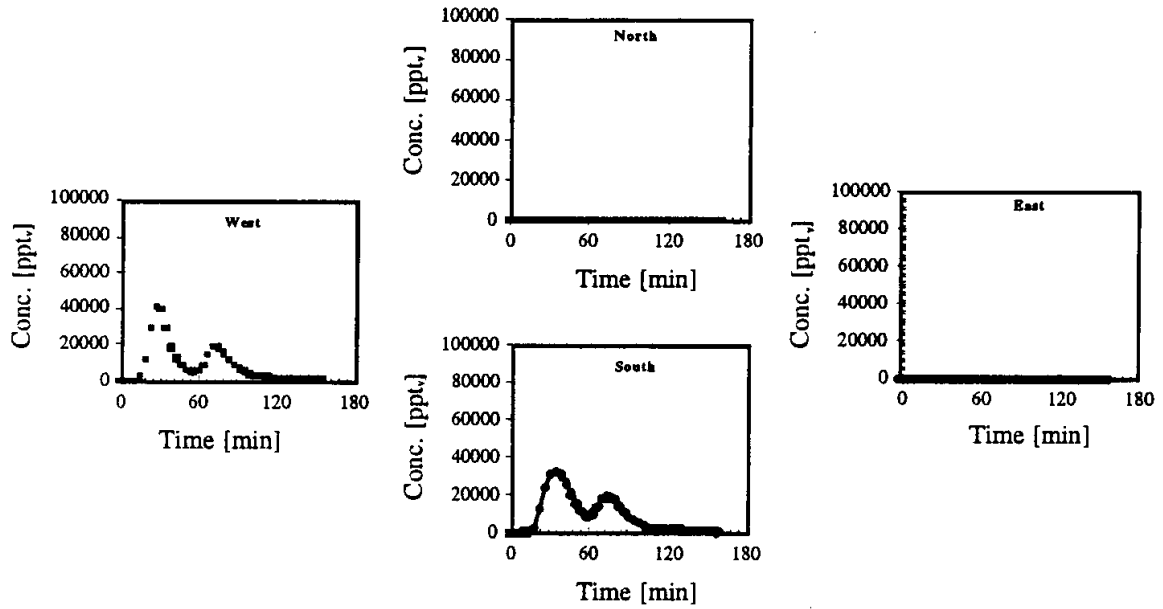

Figure SF-5. Directional soil vapor extraction well response to 0.5 mL injection of SF₆ into MP-5 (4-ft below ground surface); vapor extraction system only; flow per well 8 - 10 ft³/min (9/8/96).

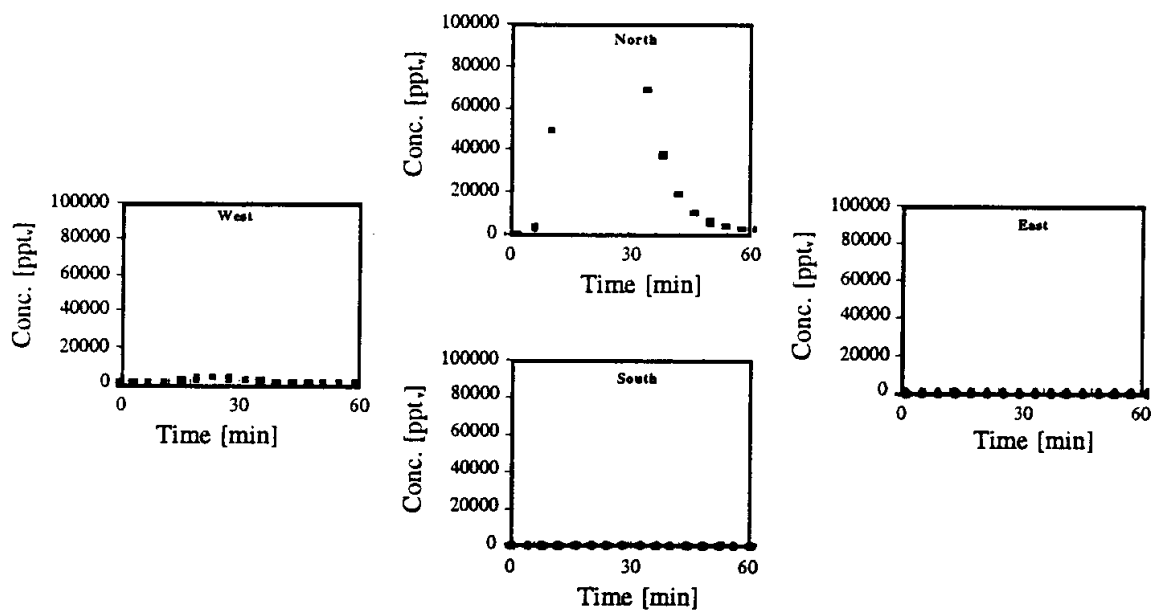

Figure SF-6. Directional soil vapor extraction well response to 0.5 mL injection of SF₆ into MP-6 (4-ft below ground surface); vapor extraction system only; flow per well 8 - 10 ft³/min (9/8/96).

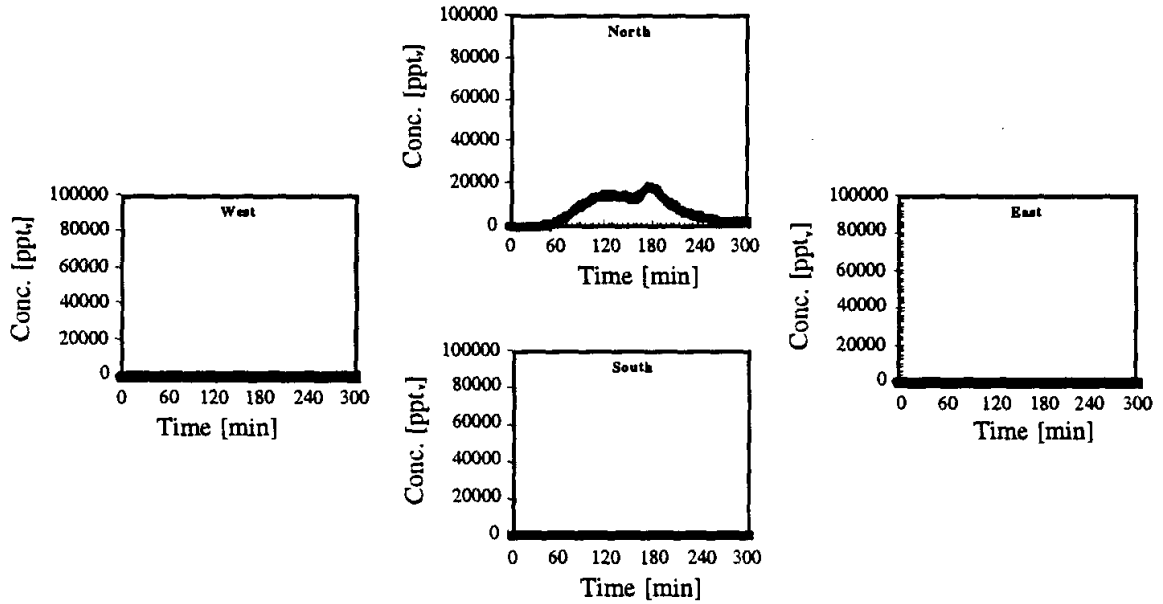

Figure SF-7. Directional soil vapor extraction well response to 0.5 mL injection of SF₆ into MP-6 (8-ft below ground surface); vapor extraction system only; flow per well 8 - 10 ft³/min (9/8/96).

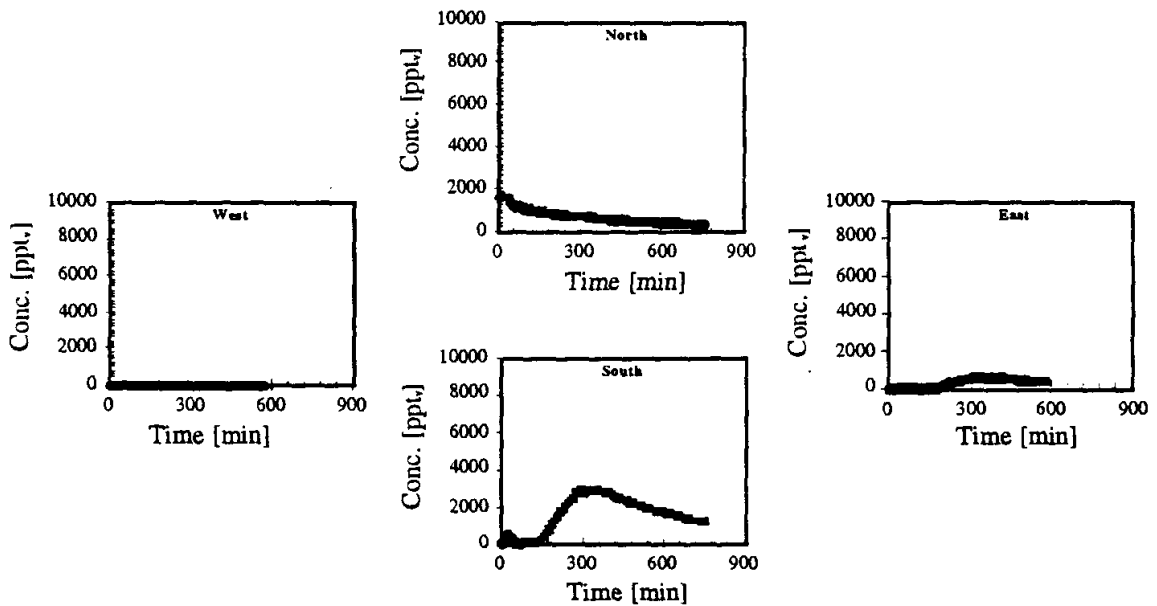

Figure SF-8. Directional soil vapor extraction well response to 0.5 mL injection of SF₆ into MP-9 (4-ft below ground surface); vapor extraction system only; flow per well 8 - 10 ft³/min (9/8/96).

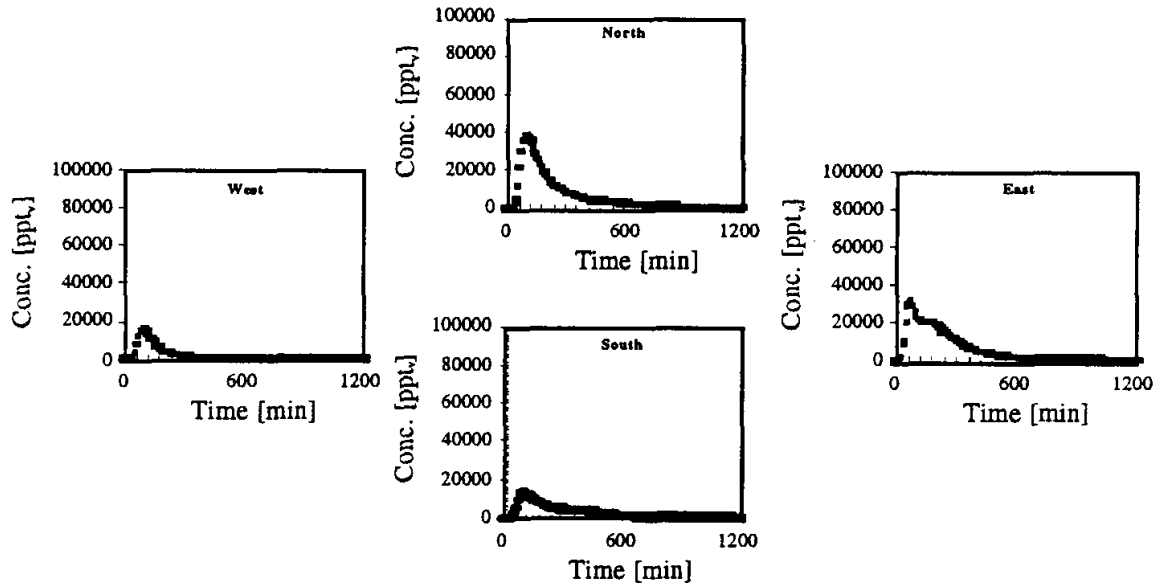

Figure SF-9. Directional soil vapor extraction well response to 0.5 mL injection of SF₆ into the air injection well; flow per extraction well ≈8 ft³/min; injection well flow 5 ft³/min (10/26 - 10/28/96).

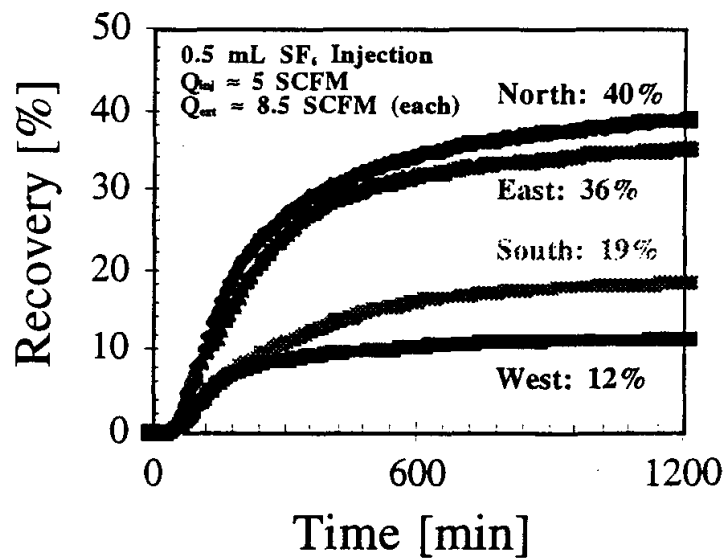

Figure SF-10. SF₆ cumulative recovery of 5 mL injection into air injection well and using the directional soil vapor extraction well (10/26 - 10/28/96); calculated cumulative recovery = 5.4 mL; flow per extraction well ≈8 ft³/min; injection well flow 5 ft³/min.

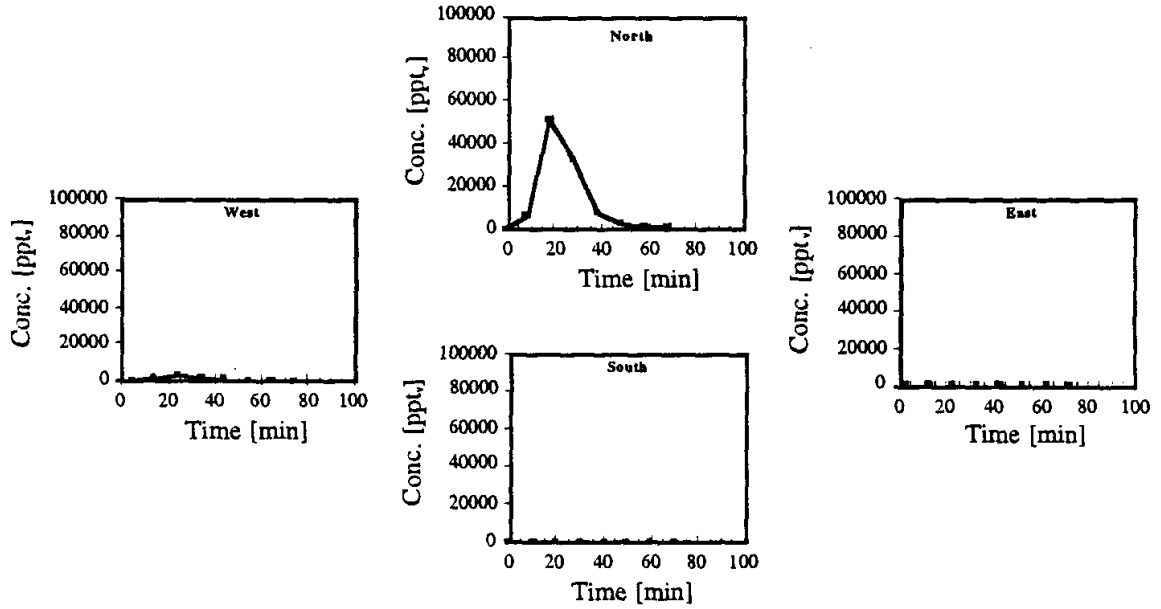

Figure SF-11. Directional soil vapor extraction well response to 0.5 mL injection of SF₆ into MP-6 (4-ft below ground surface); vapor extraction system with air injection; flow per extraction well ≈8 ft³/min; injection well flow 5 ft³/min (10/28/96).

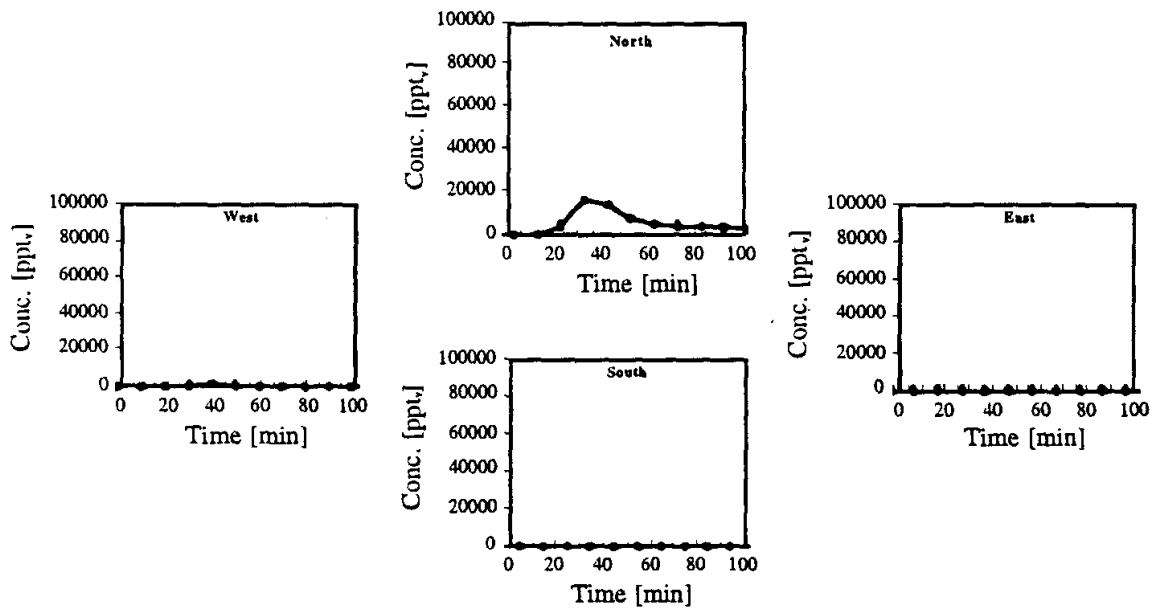

Figure SF-12. Directional soil vapor extraction well response to 0.5 mL injection of SF₆ into MP-6 (8-ft below ground surface); vapor extraction system with air injection; flow per extraction well ≈8 ft³/min; injection well flow 5 ft³/min (10/28/96).