



Defence Research and
Development Canada

Recherche et développement
pour la défense Canada



Final Report for Propylene Dissemination System for FUSION Field Trials

G.M. Chandler
Aurora Scientific Inc.

Contract Scientific Authority:
E. Yee
DRDC Suffield

The scientific or technical validity of this Contract Report is entirely the responsibility of the contractor and the contents do not necessarily have the approval or endorsement of Defence R&D Canada.

Contract Report
DRDC Suffield CR 2007-129
March 2007

Canada

Final Report for Propylene Dissemination System for FUSION Field Trials

G.M. Chandler
Aurora Scientific Inc.

Aurora Scientific Inc.
360 Industrial Parkway South, Unit 4
Aurora, ON
L4G 3V7

Contract Number: W7702-06-R122/001/EDM

Contract Scientific Authority: E. Yee (403-544-4605)

The scientific or technical validity of this Contract Report is entirely the responsibility of the contractor and the contents do not necessarily have the approval or endorsement of Defence R&D Canada.

Defence R&D Canada – Suffield

Contract Report
DRDC Suffield CR 2007-129
March 2007

Final Report for
Propylene Dissemination System for FUSION Field Trials

Contract No.: W7702-06R122/001/EDM

for

Defence Research & Development Canada Suffield
Department of National Defence
Ralston, Alberta

by

Aurora Scientific Inc.
360 Industrial Pkwy. S., Unit 4
Aurora, Ontario L4G 3V7
TEL (905) 727-5161
FAX (905) 713-6882

March 26, 2007

Table of Contents

Introduction..... 2

1. Disseminator Design..... 3

2. Software Development..... 6

3. Manufacture and Delivery of Four Disseminators 8

4. Contract Deliverables..... 9

Appendix A. Disseminator Micro Code Command Structure 10

Appendix B. Drawings..... 12

Table of Figures

Figure 1 DISEM Main Screen..... 6

Introduction

In an effort to develop new procedures for analyzing hazards associated with the release of chemical, biological, or radiological (CBR) agents, Defence Research & Development Canada Suffield will provide four (4) point source disseminators to the Fusing Sensor Information from Observing Networks (FUSION) Field Trials (FFT-07) to be held at US Army Dugway Proving Ground in September 2007.

Aurora Scientific Inc. (ASI) developed and built the gas sensors that will be used in the FUSION trial. ASI has also designed and manufactured several dissemination systems for both DRDC Suffield and Dugway Proving Ground.

The work of this contract is to: (I) design the disseminators, (II) develop a PC-based software control system, and (III) manufacture and deliver the four (4) disseminators to Dugway Proving Ground by August 2007.

1. Disseminator Design

Design of the disseminators took place during phase I of the work. The design process involved design of the flow control system, disseminator release tube, field controller, power supply, communications, and ancillary sensors. The disseminator design took into account the need for the system to be easy to set up and move and that it is man portable. Since the trials will take place at night and vehicle traffic will be banned from the test grid the disseminators had to be small and light enough for one or two men to move. Because of the size and weight of the propylene storage tanks it is not feasible to move the tanks to allow the release point to be moved. Therefore the disseminator design assumed that several propylene supply sites will be situated on the grid and that the disseminators will simply plug into the nearest available storage site.

The design work was split into the following four main tasks; flow control design, field controller design, specification and integration of ancillary sensors such as GPS, gas temperature sensor and gas pressure sensor and design of the cart/stand.

Flow Control Design

The flow control system was designed to allow from 10 to 250 litres per minute of propylene to be released from each disseminator. Each disseminator includes: a 6-tank manifold with hoses to connect to 1F propylene tanks, high flowrate regulator to control the line pressure to the mass flow controller, 300 feet (90 m) of hose, a hose reel for easy storage and movement of the hose, a mass flow controller and a release tube mounted to a telescopic pole. See drawing AS120A-F001 at the end of this document for a schematic of the flow control system.

The mass flow controller is the main component of the flow system and it is situated in the field adjacent to the release point mounted inside the Mass Flow Control Panel. The mass flow controller consists of a servo control valve and a mass flow sensor. A control signal from the micro controller sets the desired release flow rate. Internal electronics compare the flow rate signal with the command signal generating a control signal proportional to the required flow.

The mass flow controllers are the series 300 manufactured by Hastings. They are intrinsically linear and have an accuracy of better than +/-1% F.S. (full scale). The controller can detect changes in flow rate in less than 0.5 seconds and has a control response time of less than 2 seconds. The mass flow controllers are specified to work over an operating temperature range of 0-60°C.

The mass flow controller is powered by a +/-15VDC power supply located in the field controller panel.

Two quick-connect gas fittings are mounted on the mass flow controller panel, the outlet being connected to the release tube and the inlet is connected to the hose reel that contains the 90 m hose that is used to connect the system to the propylene supply cylinders.

A manifold is located at the cylinders that allows up to six cylinders to be connected together to increase the total flow rate. The 90 m long flexible hose allows the release point to be located anywhere in a 90 m radius of the cylinders.

The release tube is a 1 m long, 7.5 cm diameter pipe that is mounted with the open end facing up on a telescopic tower. The release point can be situated at any height between 1 and 3 m above ground level (AGL). At the highest gas flow rate of 250 slpm the exit velocity of the gas is less than 1 m/s.

Field Controller Design

The field controller employs a 'BRAT' single board computer (SBC) with customized firmware to manage all local control functions including flow control and data acquisition tasks. All command, data and status information is communicated via RF modem to and from the test control point (CP). Additionally, the Field Controller allows for field calibration and manual control via an on-board menu-driven user interface.

The field controller is situated in the field adjacent to the release point mounted inside the Field Control Panel. Included in the Field Control Panel are the single board computer, interface electronics for the flow rate measurement flow control and ancillary (pressure and temperature and GPS) signals, a power supply, the GPS and the RF modem. The controller is powered by a 12VDC battery to be supplied by Dugway Proving Ground that is located next to the Field Controller Panel. See drawing AS120A-E001 at the end of this document for a schematic of the electrical control system.

Ancillary Sensors

The ancillary sensors include a combined temperature and pressure sensor and a GPS. The temperature/pressure sensor is part # ST00637 made by Senstronics Ltd. The operating temperature range is -40 to +125°C with an accuracy of +/-0.25°C. The operating pressure range is 0 to 250 PSI (1725 kPa) with an accuracy of 0.25 PSI (4 kPa).

The GPS is part # GPS-17HVS made by Garmin Ltd. The GPS is designed primarily for use in marine applications and can be flush mounted in addition to pole mounted. It delivers

exceptional accuracy while standing up to the harshest environment (meets IEC 60529 IPX7 standards). The 12-channel receiver allows for continuous tracking of all visible satellites and it's WAAS capable, which means it can provide position accuracy of less than three meters (on average). The GPS 17HVS also offers excellent EMI/RFI performance which allowed for easy integration into our system that operates near our mobile computing device (field controller) and near our wireless communications equipment (RF modem).

The GPS receiver produces asynchronous serial data at true RS-232 levels in the industry-standard NMEA 0183 data format.

Cart

Each disseminator is mounted on a mobile cart that will provide a fast and easy method of moving the disseminator. The cart will contain: mass flow controller panel, field controller panel, battery, release tube with telescoping pole, GPS, radio modem and a large hose reel that will hold the 90m of hose. Note that the propylene tanks, manifold and regulator will not be mounted on the cart; these parts will be at the fixed tank locations. Only four manifolds, and regulators will be provided, one for each disseminator. This means that if the release point is to be moved to another tank location then the manifold and regulator will need to be moved as well. We expect that each disseminator will be attached to a different tank location. However in the event that the desired source locations are close together the tank manifolds have been manufactured to permit up to three disseminators to be attached to a single tank site.

Because of expected shifts in the wind direction and also because of the experimental requirement for different source locations the equipment was designed to allow for easy movement of the disseminator. Rugged metal wagons with large tires have been purchased and all of the disseminator equipment has been mounted on the wagon. The wagons are 38" long by 20" wide with a ground clearance of 11". If the disseminator only needs to be moved a short distance then the wagons can easily be pulled by one man. If they need to be moved a long distance then they can be attached to an ATV. Refer to drawing AS120A-A001 for assembly views of the wagon and equipment.

The 90m hose is held on a hose reel that is mounted on the back of the wagon. This provides a simple and easy method of winding up the hose, moving the entire disseminator to a new location and then unwinding the hose back to the propylene tanks.

2. Software Development

Phase II of the work was the development of the DISEM control and data acquisition program that will run on the main control PC to be located in the test CP building. This PC is being supplied by Dugway under a separate contract.

DISEM communicates with the four disseminators via radio modems supplied by Dugway Proving Ground. The program is written in C and runs under the Linux operating system. The flowrate of the propylene gas from each disseminator can be controlled independently. As can be seen on the main screen shown in Figure 1, the program provides data collection, release timing control, status information and a display of the location of each disseminator with respect to the grid.

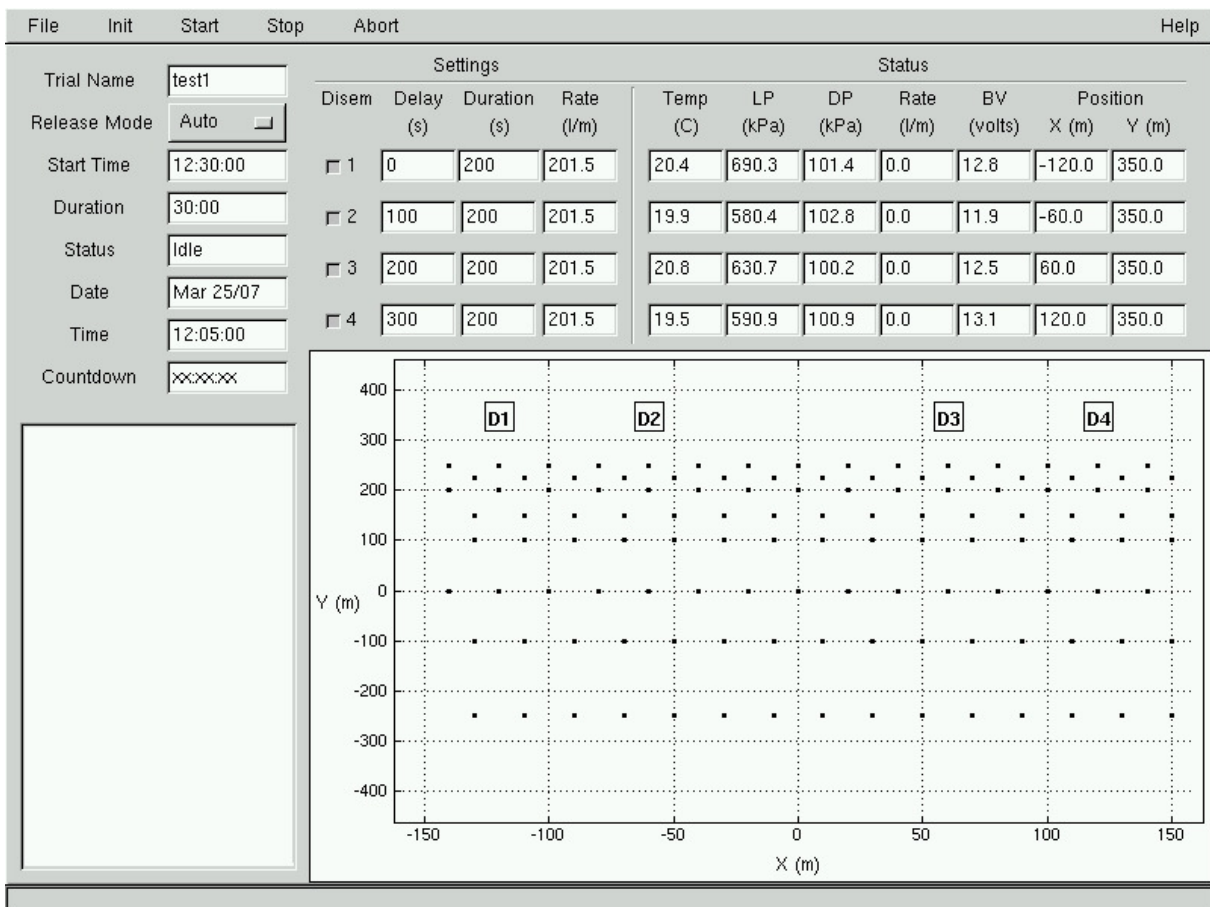

Figure 1 DISEM Main Screen

At the top of the window are the menu controls File, Init, Start, Stop and Abort. The

menu controls either drop down a menu or cause an action to occur depending on the menu selected.

The File menu provides file controls. Init is a command button that initializes all of the enabled disseminators and puts them in a known state. Start, Stop and Abort are also command buttons that Start dissemination, Stop dissemination and Abort a release in progress.

On the left side of the screen are controls to set the data logging filename, the release mode, either automatic or manual, the release start time, duration, status of the system, date and time and the Countdown timer to the start of release.

Once the release starts the program will log flow, temperature, pressure, and location data from each of the four disseminators to the file specified in the Trial Name data entry box.

The Release Mode can be set to Auto or Manual. In automatic mode the release will start at the Start Time entered. The Start button is pressed any time before the specified start time and then the time to release will be shown in the Countdown text box. If the Start button is pressed after the Start Time then the release will start immediately. In Manual mode the start time for gas release corresponds to when the Start button is pressed. As soon as the release starts the Start Time is updated to show the actual start time of the release.

Regardless of the Release Mode chosen the release duration is set by the time entered in the Duration text entry box. If Duration is set to 00:00 then the release will continue until the Stop button is pressed.

The Status text box displays the current status of the release controls and shows Idle, Waiting or Releasing.

The Main screen contains a Settings section and a Status section. The Settings section permits user input that allows the user to enable any or all of the four disseminators, set the Delay time [Delay] after start of release when the particular disseminator will start releasing, set the release Duration [Duration] and set the release Flowrate [Rate]. The Status section permits no user input and simply reports the current status of each disseminator. Status includes: propylene gas Temperature [Temp], Line Pressure [LP], Delivery Pressure [DP], Flowrate [Rate], Battery Voltage [BV], and Disseminator Location in X and Y grid coordinates [X], [Y]. Note that the origin of the grid coordinates is the physical centre point of the grid. Grid coordinates are rotated so that the X axis is in line with the sensor line with the Y axis perpendicular to the sensor line.

The large graphical area on the screen shows the position of the disseminators relative to the grid. The position data is derived from the GPS unit that is included with each disseminator.

3. Manufacture and Delivery of Four Disseminators

Phase III covered the manufacture and delivery of the disseminators to Dugway Proving Ground.

Manufacturing commenced immediately after completion of the design phase of the work and was completed by March 31, 2007. The completed disseminators will be stored safely and completely assembled at Aurora Scientific Inc. until they are shipped to Dugway which will be during August of 2007. The disseminators will be shipped on pallets by truck so that when they arrive at Dugway they will be unpacked and ready for use. No assembly will be required on site.

4. Contract Deliverables

The deliverables for this contract consist of four (4) disseminators, the DISEM software and three (3) copies of a bound final report describing the work undertaken. A separately bound Installation, Operation and Maintenance Manual for the disseminators as well as a separately bound Users Manual for the DISEM program will be shipped along with the disseminators. The disseminators will be shipped to Dugway Proving Ground during August 2007 well in advance of the start of the trial that is scheduled to begin in early September.

Appendix A. Disseminator Micro Code Command Structure

The commands will be formatted as *aa?hh#ss using only printable ASCII characters. Where the * denotes the start of frame character, aa are two lower case hex characters which are the Disseminator serial number (aa=fe in examples). The ? is the upper case command, hh are the command parameter or data values in varying lengths, # is the end of frame character, and finally ss are 2 lower case hex digits which are the check sum for the characters from * through # inclusive.

Commands

MASS FLOW RATE

Command issued to instruct remote controller to adjust mass flow to specified rate (3 digits).

Command	* aaMhhh # ss	
e.g.	*feM125#fd	Rate set to 125 L/min
Successful reply:	*feR#6a	
Unsuccessful reply:	*feN#66	

QUERY

Command issued to query remote controller for Temperature (3 digits with '-' when negative), Line Pressure (5 digits), Disseminator Pressure (5 digits), Disseminator Full Flag (1 = full, 0 = not full), and depending on the controller type Battery voltage (3 digits), and Mass flow rate (3 digits).

Command	* aaQss	
e.g.	*feQ69	
Successful reply:	*feR02101605015051129125#59	
	Temp. 21C, Line Pressure 160.5 kPa, Disseminator Pressure 150.5 kPa, Full, 12.9 volts, 125 L/minute.	
Unsuccessful reply:	*feN#66	

A special Query command is used to retrieve GPS coordinates (19 digits) and time stamp (6

digits) from the controller. Note: Latitude has 8 digits plus North=1/South=0 indicator, while Longitude has 9 digits plus East=1/West=0 indicator. Coordinates are in degrees and minutes, Latitude is in the format dd mm.mmmm while Longitude is in the format ddd mm.mmmm.

Command * aaQ6ss
e.g. *feQ6#ca
Successful reply: *feR3723000011215800000133059#86
 Latitude 37o 23.0000' North, Longitude 121o 58.0000' West
 Time 13:30:59
Unsuccessful reply: *feN#66

EMERGENCY STOP

This command instructs the controller to enter into a SAFE state, in case of an emergency.

Command * aaE#ss
eg *feE#5d
Successful reply: *feR#6a
Unsuccessful reply: *feN#66

Appendix B. Drawings

<u>Drawing</u>	<u>Title</u>
AS120A-A001 Sheet 1	Assembly Drawing of Disseminator Cart
AS120A-A001 Sheet 2	Assembly Drawing of Disseminator Cart
AS120A-A001 Sheet 3	Assembly Drawing of Disseminator Cart
AS120A-E001	Electrical Schematic of Disseminator
AS120A-F001	Flow Schematic of Disseminator

Parts List			
ITEM	QTY	PART NUMBER	DESCRIPTION
1	1	8086787	Disseminator Wagon
2	1	AE_1032_500	Field Control Panel
3	1	117-4-350	Cox reels hose reel
4	1	AE_1033_500	Mass Flow Control Panel
5	1	3" diameter PVC pipe	Disseminator Tube
6	1	GPS 16	Global Positioning Sytem
7	1	24R	Battery

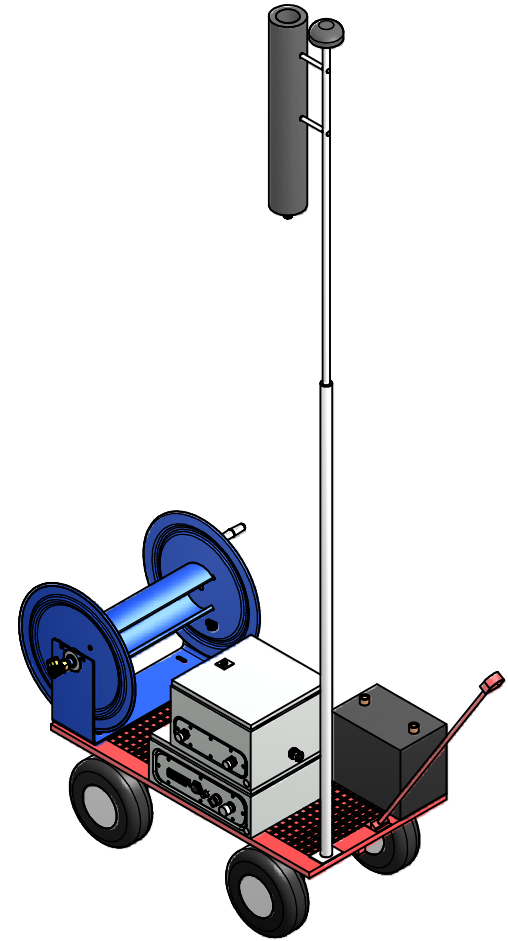
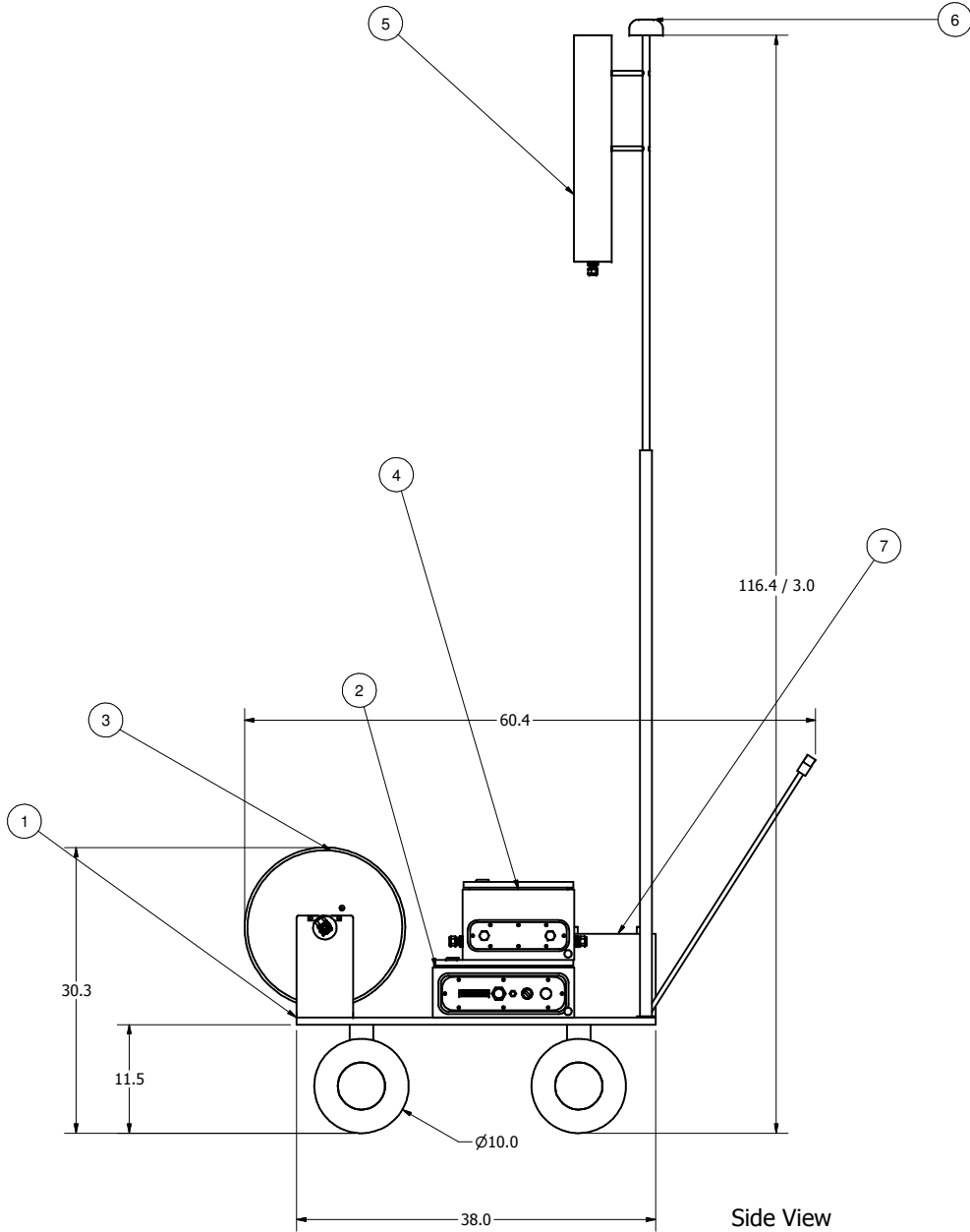

DRAWN Matt Borkowski		1/29/2007	Aurora Scientific Inc. 360 Industrial Pkwy. S., Unit 4 Aurora, ON, Canada L4G 3V7 905-727-5161	
CHECKED			TITLE DRES Gas Disseminator	
QA			SIZE C	
MFG			DWG NO 120A-E003	
APPROVED			REV	
AS120A-A001.idw		SCALE	SHEET 1 OF 3	

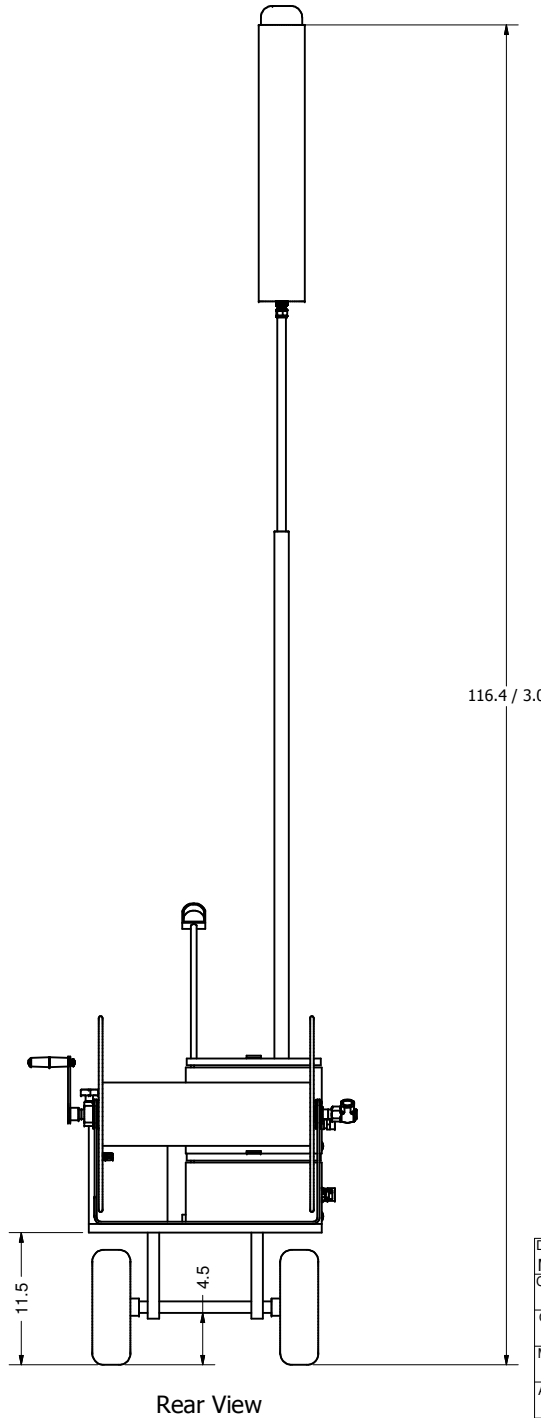
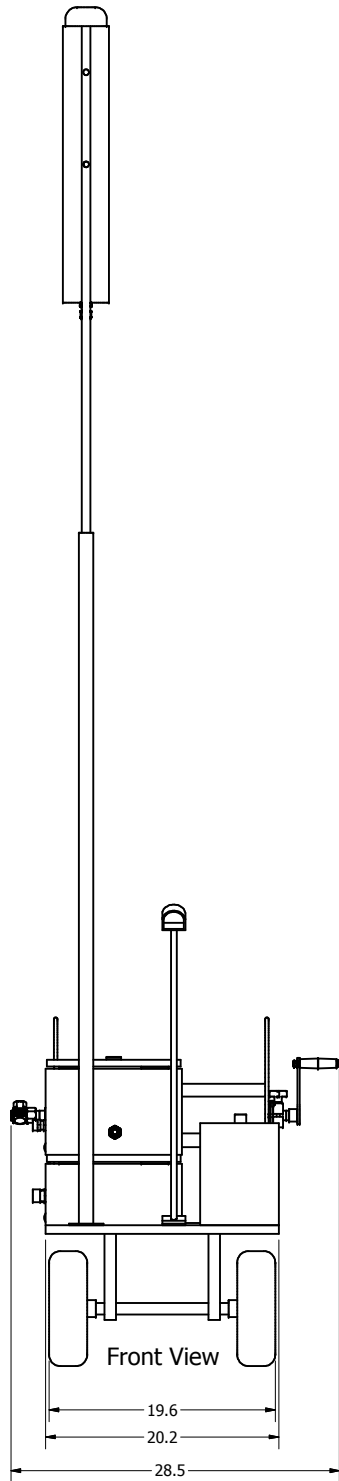

DRAWN Matt Borkowski		1/29/2007		Aurora Scientific Inc. 360 Industrial Pkwy. S., Unit 4 Aurora, ON, Canada L4G 3V7 905-727-5161	
CHECKED					
QA				TITLE	
MFG				DRES Gas Disseminator	
APPROVED				SIZE	REV
				C	DWG NO 120A-E003
AS120A-A001.idw		SCALE		SHEET 2 OF 3	

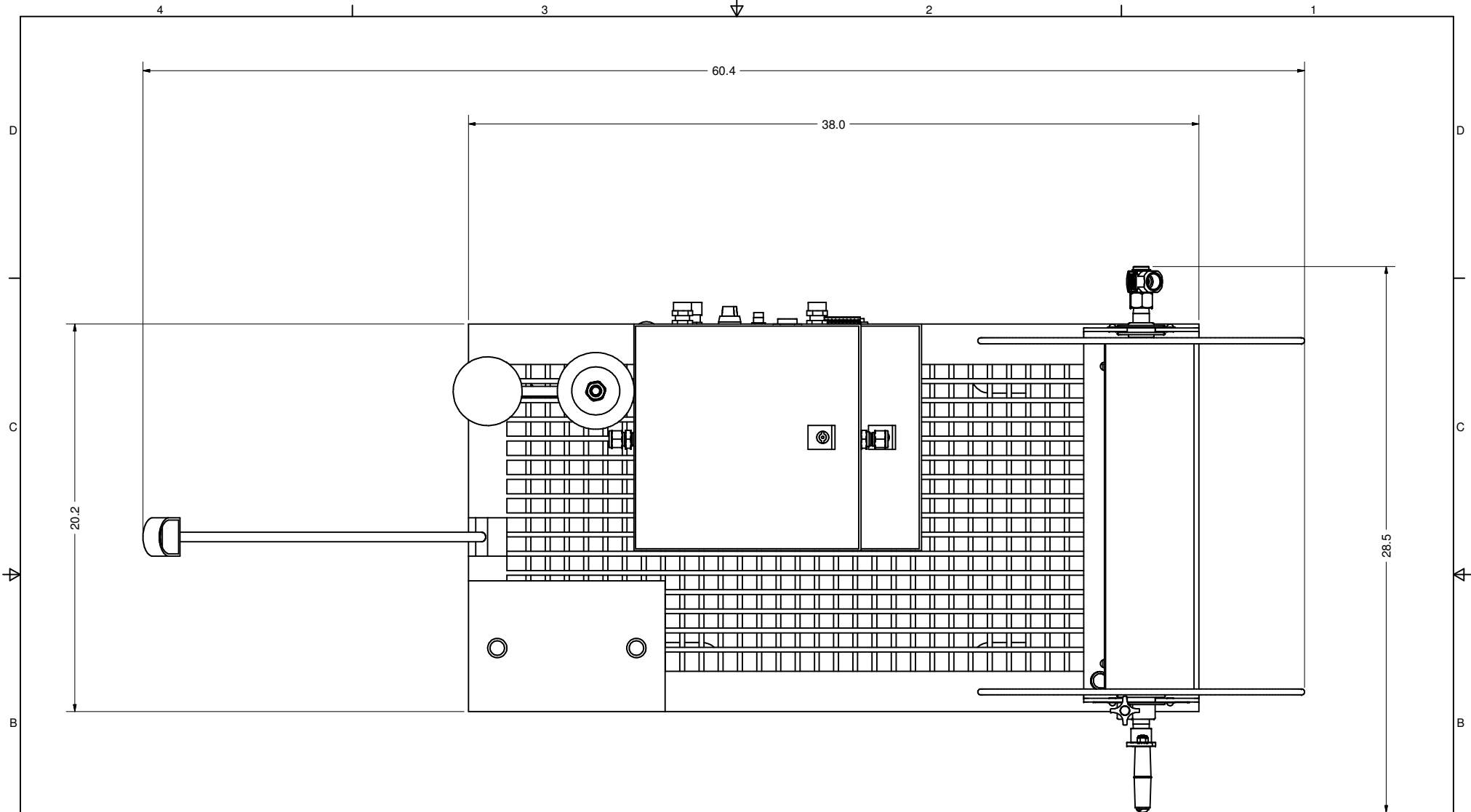

Top View

DRAWN Matt Borkowski		1/29/2007		Aurora Scientific Inc. 360 Industrial Pkwy. S., Unit 4 Aurora, ON, Canada L4G 3V7 905-727-5161	
CHECKED					
QA				TITLE	
MFG				DRES Gas Disseminator	
APPROVED				REV	
		SIZE C		DWG NO 120A-E003	
AS120A-A001.idw		SCALE		SHEET 3 OF 3	

Mass Flow Controller Panel

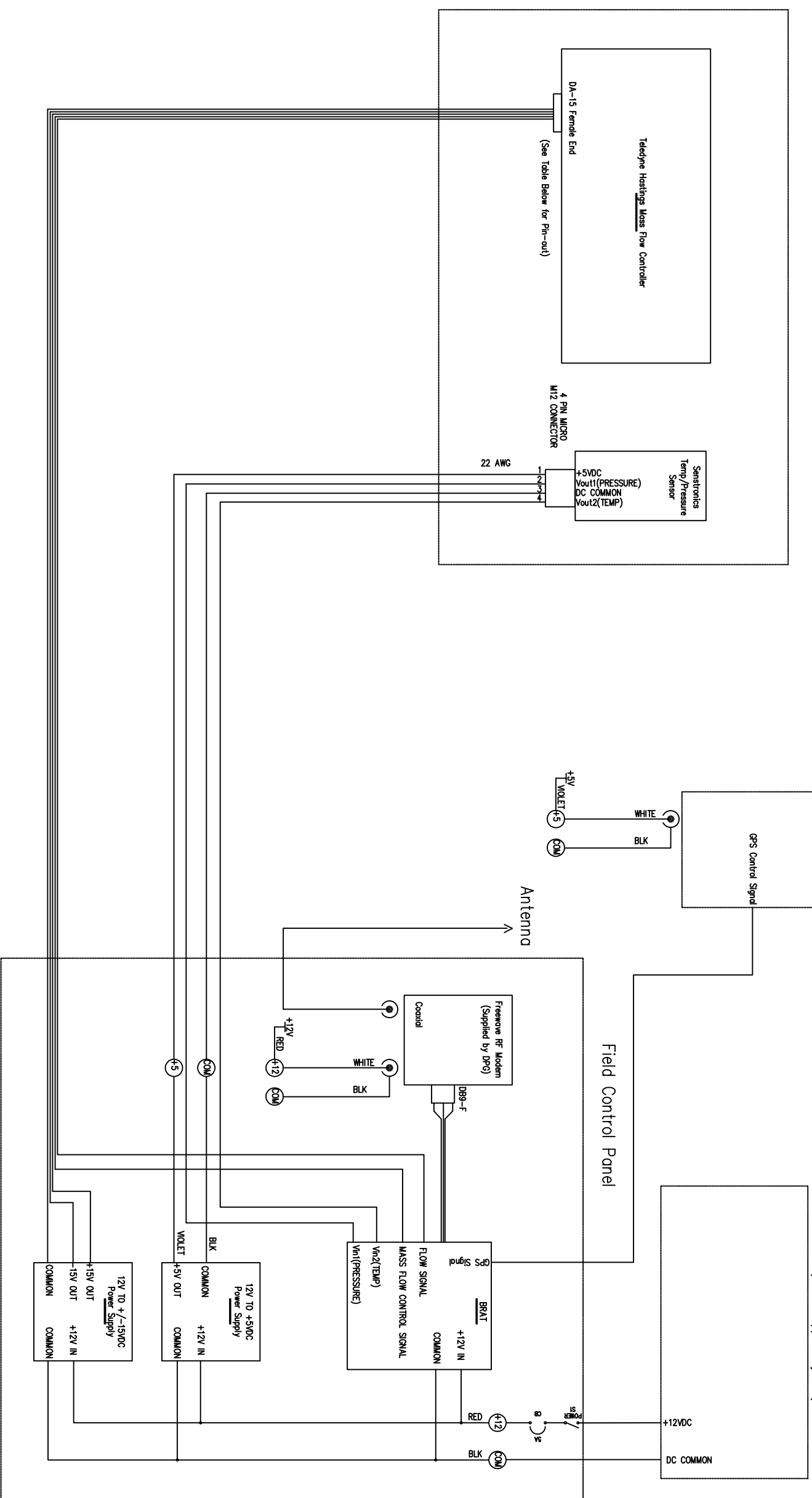

Mass Flow Controller Pin-Out

Pin Number	H Board	U Board
1	No Connect	Signal Common
2	No Connect	No Connect
3	No Connect	No Connect
4	No Connect	+15VDC
5	Signal Common	No Connect
6	Output 0-5V (+-20mA)	Output 0-5VDC (+-20mA)
7	Case Ground	Signal Common
8	Valve Override	Case Ground
9	-15VDC	Valve Override
10	No Connect	No Connect
11	+15VDC	-15VDC
12	Signal Common	External Input
13	External Input	Signal Common
14	Set Point 0-5V (+-20mA)	Signal Common
15	No Connect	Set Point 0-5 VDC (+-20mA)

REV	ECO	ZONE	DESCRIPTION	DATE	BY	APP'D

This drawing is CONFIDENTIAL PROPERTY of AURORA SCIENTIFIC INC. and may not be used, reproduced, published or disclosed to others without authorization of AURORA SCIENTIFIC INC. If located, this drawing is subject to return upon demand, and with the understanding that it is not to be used in any way detrimental to AURORA SCIENTIFIC INC.	
CLIENT	Defence Research Suffield
PROJECT	#1702 DRES Gas Disseminator
MATERIAL	DO NOT SCALE DRAWING SCALE NTS
TOLERANCES	DESIGNED
XXX ±0.01"	DRAWN MB
XXX ±0.005"	CHECKED
FRACTIONS > 8 ± 1/64"	APPROVED
ANGLES > 8 ± 1/2°	DATE
	18-JAN-07
TITLE	Gas Disseminator
	Electrical Interconnection Drawing
DWG No.	AS120A-E001
REV	0

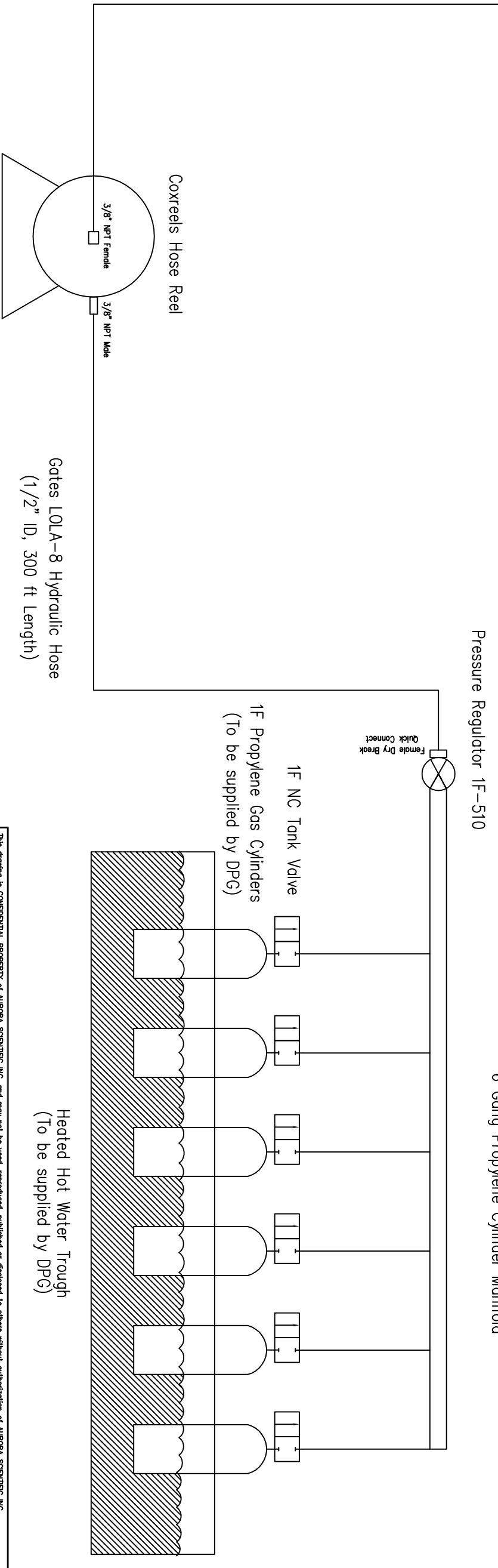
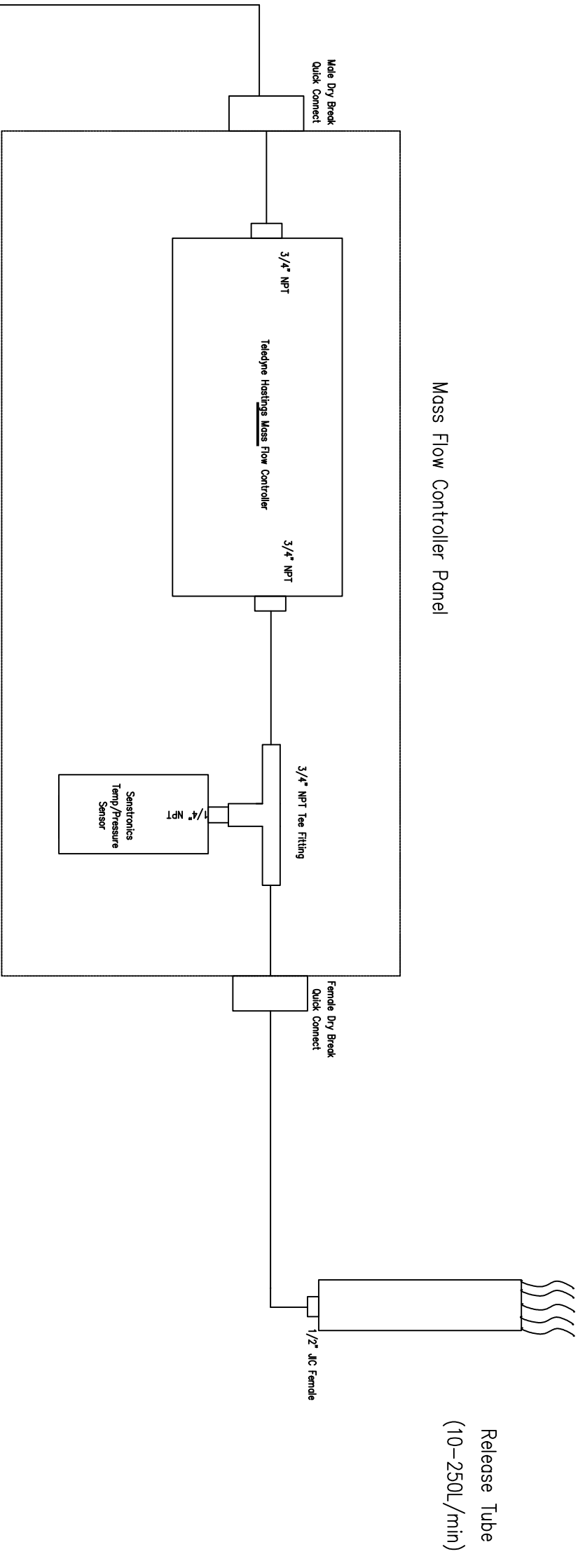

<p>This drawing is CONFIDENTIAL PROPERTY of AURORA SCIENTIFIC INC. and may not be used, reproduced, published or disclosed to others without authorization of AURORA SCIENTIFIC INC. If loaned, this drawing is subject to return upon demand, and with the understanding that it is not to be used in any way detrimental to AURORA SCIENTIFIC INC.</p>	
CLIENT	Defence Research Sufield
PROJECT	#1702 DRES Gas Disseminator
MATERIAL	DO NOT SCALE DRAWING SCALE NTS
TOLERANCES	DESIGNED
XXX	± 0.01"
KXXX	+/- 0.005"
FRACTIONS > 8	1/64"
ANGLES	1/2°
DATE	DATE
BY	MB
APP'D	11-JAN-07
DESCRIPTION	TITLE
	Gas Disseminator
	Mechanical Interconnection Drawing
REV	DWG No.
ECO	AS120A-F001
ZONE	REV
	0

UNCLASSIFIED
SECURITY CLASSIFICATION OF FORM
(highest classification of Title, Abstract, Keywords)

DOCUMENT CONTROL DATA		
(Security classification of title, body of abstract and indexing annotation must be entered when the overall document is classified)		
<p>1. ORIGINATOR (the name and address of the organization preparing the document. Organizations for who the document was prepared, e.g. Establishment sponsoring a contractor's report, or tasking agency, are entered in Section 8.)</p> <p>Aurora Scientific Inc. 360 Industrial Parkway South, Unit 4 Aurora, ON L4G 3V7</p>	<p>2. SECURITY CLASSIFICATION (overall security classification of the document, including special warning terms if applicable)</p> <p style="text-align: center; font-size: large;">UNCLASSIFIED</p>	
<p>3. TITLE (the complete document title as indicated on the title page. Its classification should be indicated by the appropriate abbreviation (S, C or U) in parentheses after the title).</p> <p style="text-align: center;">Final Report for Propylene Dissemination System for FUSION Field Trials (U)</p>		
<p>4. AUTHORS (Last name, first name, middle initial. If military, show rank, e.g. Doe, Maj. John E.)</p> <p style="text-align: center;">Chandler, G.M.</p>		
<p>5. DATE OF PUBLICATION (month and year of publication of document)</p> <p style="text-align: center;">March 2007</p>	<p>6a. NO. OF PAGES (total containing information, include Annexes, Appendices, etc)</p> <p style="text-align: center;">18</p>	<p>6b. NO. OF REFS (total cited in document)</p> <p style="text-align: center;">0</p>
<p>7. DESCRIPTIVE NOTES (the category of the document, e.g. technical report, technical note or memorandum. If appropriate, enter the type of report, e.g. interim, progress, summary, annual or final. Give the inclusive dates when a specific reporting period is covered.)</p> <p style="text-align: center;">Final Contract Report</p>		
<p>8. SPONSORING ACTIVITY (the name of the department project office or laboratory sponsoring the research and development. Include the address.)</p> <p style="text-align: center;">Defence R&D Canada – Suffield, PO Box 4000, Station Main, Medicine Hat, AB T1A 8K6</p>		
<p>9a. PROJECT OR GRANT NO. (If appropriate, the applicable research and development project or grant number under which the document was written. Please specify whether project or grant.)</p> <p style="text-align: center;">CRTI-02-0093RD</p>	<p>9b. CONTRACT NO. (If appropriate, the applicable number under which the document was written.)</p> <p style="text-align: center;">W7702-06-R122</p>	
<p>10a. ORIGINATOR'S DOCUMENT NUMBER (the official document number by which the document is identified by the originating activity. This number must be unique to this document.)</p> <p style="text-align: center;">DRDC Suffield CR 2007-129</p>	<p>10b. OTHER DOCUMENT NOs. (Any other numbers which may be assigned this document either by the originator or by the sponsor.)</p>	
<p>11. DOCUMENT AVAILABILITY (any limitations on further dissemination of the document, other than those imposed by security classification)</p> <p>(x) Unlimited distribution () Distribution limited to defence departments and defence contractors; further distribution only as approved () Distribution limited to defence departments and Canadian defence contractors; further distribution only as approved () Distribution limited to government departments and agencies; further distribution only as approved () Distribution limited to defence departments; further distribution only as approved () Other (please specify):</p>		
<p>12. DOCUMENT ANNOUNCEMENT (any limitation to the bibliographic announcement of this document. This will normally corresponded to the Document Availability (11). However, where further distribution (beyond the audience specified in 11) is possible, a wider announcement audience may be selected).</p> <p style="text-align: center;">No limitation on document announcement</p>		

UNCLASSIFIED
SECURITY CLASSIFICATION OF FORM

13. ABSTRACT (a brief and factual summary of the document. It may also appear elsewhere in the body of the document itself. It is highly desirable that the abstract of classified documents be unclassified. Each paragraph of the abstract shall begin with an indication of the security classification of the information in the paragraph (unless the document itself is unclassified) represented as (S), (C) or (U). It is not necessary to include here abstracts in both official languages unless the text is bilingual).

(U) In an effort to develop new procedures for analyzing hazards associated with the release of chemical, biological, or radiological agents, Defence R&D Canada – Suffield will provide four (4) point disseminations to the Fusing Sensor Information from Observing Networks (FUSION) Field Trails (FFT 07) to be held at US Army Dugway Proving Ground in September 2007. Aurora Scientific Inc. (ASI) developed and built the gas sensors that will be used in the FUSION trial. ASI has also designed and manufactured several dissemination systems for both DRDC Suffield and Dugway Proving Ground. The work of this contract is to: (I) design the disseminator, (II) develop a PC-based software control system, and (III) manufacture and deliver the four (4) disseminators to Dugway Proving Ground by August 2007.

14. KEYWORDS, DESCRIPTORS or IDENTIFIERS (technically meaningful terms or short phrases that characterize a document and could be helpful in cataloguing the document. They should be selected so that no security classification is required. Identifies, such as equipment model designation, trade name, military project code name, geographic location may also be included. If possible keywords should be selected from a published thesaurus, e.g. Thesaurus of Engineering and Scientific Terms (TEST) and that thesaurus-identified. If it is not possible to select indexing terms which are Unclassified, the classification of each should be indicated as with the title.)

Sensor Data Fusion
Atmospheric Dispersion Field Experiment
Propylene Dissemination System