



NetZero Plus (NZ+) Joint Capability Technology Demonstration



Report Documentation Page

Form Approved
OMB No. 0704-0188

Public reporting burden for the collection of information is estimated to average 1 hour per response, including the time for reviewing instructions, searching existing data sources, gathering and maintaining the data needed, and completing and reviewing the collection of information. Send comments regarding this burden estimate or any other aspect of this collection of information, including suggestions for reducing this burden, to Washington Headquarters Services, Directorate for Information Operations and Reports, 1215 Jefferson Davis Highway, Suite 1204, Arlington VA 22202-4302. Respondents should be aware that notwithstanding any other provision of law, no person shall be subject to a penalty for failing to comply with a collection of information if it does not display a currently valid OMB control number.

1. REPORT DATE 05 MAR 2009		2. REPORT TYPE		3. DATES COVERED 00-00-2009 to 00-00-2009	
4. TITLE AND SUBTITLE NetZero Plus (NZ+) Joint Capability Technology Demonstration				5a. CONTRACT NUMBER	
				5b. GRANT NUMBER	
				5c. PROGRAM ELEMENT NUMBER	
6. AUTHOR(S)				5d. PROJECT NUMBER	
				5e. TASK NUMBER	
				5f. WORK UNIT NUMBER	
7. PERFORMING ORGANIZATION NAME(S) AND ADDRESS(ES) Department of Defense, Joint Capability Technology Demonstration (JCTD), Washington, DC, 20301				8. PERFORMING ORGANIZATION REPORT NUMBER	
9. SPONSORING/MONITORING AGENCY NAME(S) AND ADDRESS(ES)				10. SPONSOR/MONITOR'S ACRONYM(S)	
				11. SPONSOR/MONITOR'S REPORT NUMBER(S)	
12. DISTRIBUTION/AVAILABILITY STATEMENT Approved for public release; distribution unlimited					
13. SUPPLEMENTARY NOTES Presented at the NDIA Environment, Energy Security & Sustainability (E2S2) Symposium & Exhibition held 4-7 May 2009 in Denver, CO.					
14. ABSTRACT					
15. SUBJECT TERMS					
16. SECURITY CLASSIFICATION OF:			17. LIMITATION OF ABSTRACT Same as Report (SAR)	18. NUMBER OF PAGES 25	19a. NAME OF RESPONSIBLE PERSON
a. REPORT unclassified	b. ABSTRACT unclassified	c. THIS PAGE unclassified			



NetZero Plus JCTD



Foamed Tent

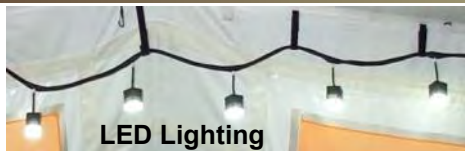

LED Lighting



DREAM (3kW)



Electro-Luminescence



Dome w/ Alt Energy



EPCC

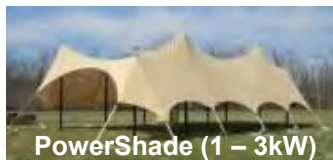

PowerShade (1 - 3kW)

JCTD BUDGET

	FY08	FY09	FY10
AS&C (Cash)	\$2.0M	\$2.0M	\$2.0M
Army REF / Energy Security TF (Cash)	\$0.75M	\$0.75M	\$0.75M
TOTAL CASH	\$2.75M	\$2.75M	\$2.75M
Service In-Kind Contributions	\$12.33M	\$11M	\$6M
Total	\$15.05M	\$13.75M	\$8.75M

Total Program Cost: \$37.55M

Warfighter Problem / Solution

- **Problem:** Vulnerable lines of communication are subject to attack. Logistics convoys carry all classes of supplies to include fuel for power generation at Forward Operating Bases
- **Solution:** Leverage GOTS and COTS technologies to reduce fuel requirements at forward operating bases through reduced energy demand, efficient power distribution and increased alternative supply.

MANAGEMENT TEAM

- **Lead Service:** Army
- **COCOM Sponsor:** USCENTCOM
- **Technical Manager:** Power Surety TF
- **Operational Manger:** USCENTCOM J8
- **Transition Manager:** PM-MEP
- **Supporting CoComs:** USSOUTHCOM
- **Supporting Services/Agencies:** DLA, USMC



The Problem





The Need... Recommended a JCTD

UNCLASSIFIED//FOR OFFICIAL USE ONLY

JOINT STAFF RAPID VALIDATION AND RESOURCING REQUEST

(U) Title: Renewable Energy System

(U) Submitted by: Commanding General, Multi-National Force-West (MNF-W)

(U) Date Certified/Prioritized by Combatant Commander: July 25, 2006

(U) Relative Priority: Priority 1

(U) General Description:

(U//FOUO) Electrical power is a I MEF (FwS) mission-critical requirement, without which operations in Multi-National Force West (MNF-W) will be severely degraded. More than ever our operating forces rely on the use electrical power to support critical command and control (C2) functions: intelligence, surveillance, and reconnaissance (ISR) assets; and life support services. To improve the security posture of the Al-Anbar Province of Iraq, MNF-W requires a renewable and self-sustainable energy solution to support forward operating bases (FOBs), combat outposts (COPs), and observation posts (OPs) throughout MNF-W's battlespace.

(U//FOUO) Current means of supporting MNF-W's outlying bases consist of frequent logistic resupply convoys of Class I (subsistence), Class III (petroleum, oil, and lubricants), and Class V (ammunition), with a preponderance of Class III (petroleum). The constant threat of improvised explosive devices (IEDs), rocket propelled grenades (RPGs), and small arms fire (SAF) attacks along known ground lines of communications (GLOCs), and the necessity to traverse them to reach our outlying bases, places our Marines, soldiers, and sailors in harm's way each time we send out a convoy.

(U//FOUO) Current solutions-such as providing additional security to our logistics convoys and conducting convoy operations during the hours of darkness-are inadequate, as they do not reduce the number of convoys on the road. Additionally, these current solutions divert our focus of effort from developing the Iraqi Security Force (ISF) to providing convoy security for our own logistics support. A proposed alternate solution-one that reduces the number of convoys while providing an additional capability to outlying bases-is to augment our use of fossil fuels with renewable energy, such as photovoltaic solar panels and wind turbines, at our outlying bases. **By reducing the need for Class III (petroleum) at our outlying bases, we can decrease the frequency of logistics convoys on the road, thereby reducing the danger to our Marines, soldiers, and sailors.**

(U//FOUO) Additionally, as we transfer control to the Iraqis, the addition of renewable and self-sustainable energy at the outlying bases will enable the Iraqis to operate independently, lessening the need for Coalition Forces to provide future logistics support.

UNCLASSIFIED//FOR OFFICIAL USE ONLY

By reducing the need for Class III (petroleum)...we can decrease the frequency of logistics, convoys on the road, thereby reducing the danger to our Marines, Soldiers and Sailors.



UNCLASSIFIED//FOR OFFICIAL USE ONLY

HEADQUARTERS
MULTI-NATIONAL CORPS - IRAQ
BAGHDAD, IRAQ
APO AE 09342

FICI-GT-FMD

11 FEB 07

MEMORANDUM THRU Commander, Multi-National Force-Iraq, APO AE 09342-2001

FOR Commander, United States Central Command, CCG8, 7115 South Boundary Blvd, MacDill AFB, Florida 33621-5101

SUBJECT: Candidate Joint Urgent Operational Need (JUON) Statement for Renewable Energy System (U)

- (U) Reference: Joint Staff Rapid Validation and Resourcing Request, Title: Renewable Energy Source, 25 Jul 06.
- (U//FOUO) Request CENTCOM review the concept, capabilities, and requirements of the Renewable Energy System candidate JUON towards feasibility and applicability in supporting military operations in Multi-National Force-West (MNF-W) battlespace. To improve the security posture of the Al-Anbar Province in Iraq, MNF-W is requesting a renewable and self-sustainable energy solution to support their forward operating bases (FOBs), combat outposts (COPs), and observation posts (Ops).
- (U//FOUO) A review by the MNC-I staff of this candidate JUON validates the requirement, however, there are concerns regarding the maturity of the technology and whether the benefits are such that they warrant implementation at this time. Request CENTCOM conduct a scientific and technological review of this JUON candidate and provide a developmental way ahead. **And if this technology is not mature enough to develop an operational test system by Jan 08, then request this technology be pursued via other DoD avenues, such as an Advanced Concept Technology Demonstration (ACTD) or Joint Concept Technology Demonstration (JCTD).**
- (U) Point of contact is LTC Donald Koehler, Chief, C-3 FMD, DSN: 318-822-4013, email: donald.koehler@s-iraq.centcom.smil.mil

RAYMOND T. ODIERNO
Lieutenant General, USA
Commanding

UNCLASSIFIED//FOR OFFICIAL USE ONLY

Request this technology be pursued via other DoD avenues, such as...Joint Concept Technology Demonstration (JCTD).



NetZero Plus JCTD Program Schedule



NetZero+ JCTD	FY08				FY09				FY10				FY11			
	1Q	2Q	3Q	4Q	1Q	2Q	3Q	4Q	1Q	2Q	3Q	4Q	1Q	2Q	3Q	4Q
	OND	JFM	AMJ	JAS	OND	JFM	AMJ	JAS	OND	JFM	AMJ	JAS	OND	JFM	AMJ	JAS
Documentation																
Notified as Rolling Start	▲															
JCTD Start			▲													
Implementation Directive			■	■	■											
Management and Transition Plan				▲												
Assessment Organization Identified		▲				▲										
Integrated Assessment Plan (IAP)						▲										
Concept of Employment							▲									
Training Support Packages								▲								
Technology Insertion																
Eskimo (Foam Tent)							▲									
EPCC								▲								
Hybrid Tactical Power (Dome)		▲						▲								
Exterior Perimeter Lights							▲									
Interior Lights							▲									
Larger Dome								▲								
Alternative Structures							▲									
DREAM							▲									
Microgrid/Power Generation								▲								
Hybrid Prime Power										▲						
Assessments																
Technology Selection	Tech Testing and Selection for each Phase															
Data Recording		■	■	■	■	■	■	■	■	■	■	■	■	■	■	▲
LUA Demonstration							▲								▲	
MUA Demonstration															▲	
MUA Memorandum														▲		
Transition																
POM Cycle	FY12 PBR, Service Build and Submit															
	BA 4 Bridging Funds															
	▲ Complete ▲ Draft ▲ Overdue ▲ Milestone															
	 Completed Planned POM Activities															



Energy Efficient Shelter Evaluation Overview



- **Goals and Objectives:**

- Gather baseline energy usage data in a relevant environment
- Gather energy usage data for different configurations of energy saving technologies
- Create a comparative and comprehensive report based on this data

- **Expeditionary:**

- Shelters:
- Shading Systems:
- Lighting:
- Insulation:

- **Enduring Shelters:**

- Spray foam insulation
- Dome

- **Data collection and analysis**

- Ultimately, reducing generator requirements and fuel
- Power Usage will be primary metric

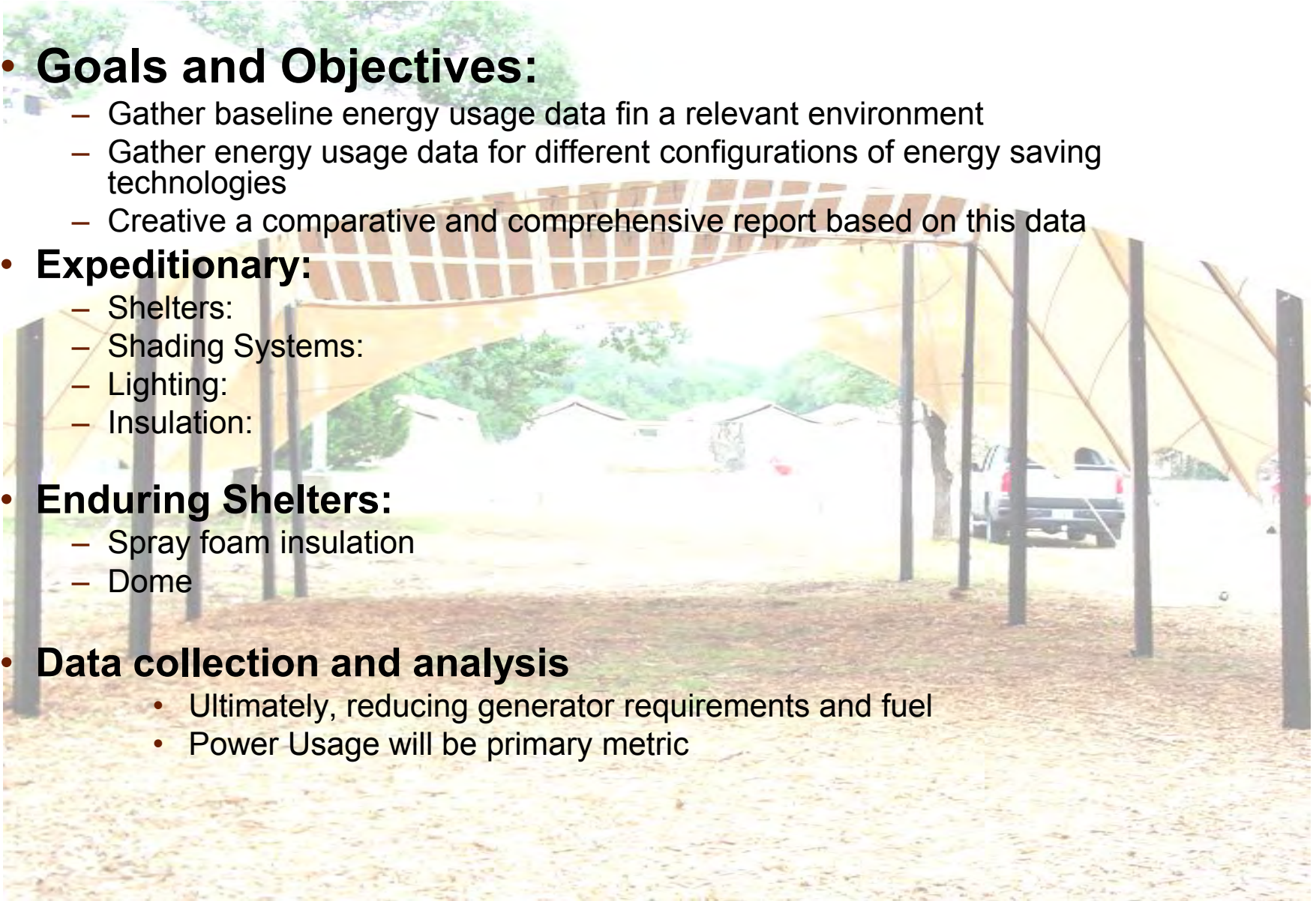



Energy Efficient Structures-Expeditionary

Technologies being brought to the table

- New airbeam energy efficient tents
- Power Shades
- Solar Shades
- Honeycomb insulation liner (temper tent)
- Air gel insulation liner (temper tent)





Energy Efficient Structures-Expeditionary



Flexible, Electroluminescent (EL) Lighting Surfaces:

- Provide general illumination for shelters
- Decreases deployment time, weight, and cube
- Polymer-based lighting surfaces are flexible, durable and safe
- Can be printed on multiple substrates (including fabric)
- Puncture of EL lamp does not cause failure

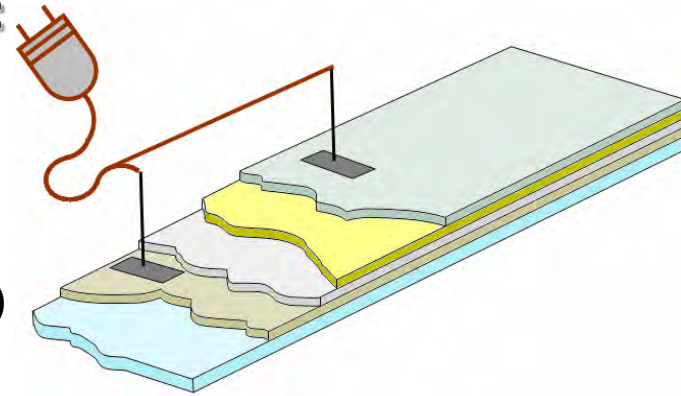



Energy Efficient Structures - Enduring



Dome Structure

- 2 Story Dome
- Size - 72' x 27'
- Energy efficient HVAC units
- Earth Return Ventilation (ERV)
- Energy efficient lighting
- Brigade TOC (footprint)





Energy Efficient Structures - Enduring

Exterior Spray Foam

- Foam insulate temporary tents, containerized living units, office spaces and freezer units to decrease air and dust infiltration.
- Foam is deployed using self-contained, self-powered, Conex-transported spray kits.
- Foam is applied by experts who prepare the structure, apply foam, apply protective coating, and monitor air exchange.



Before



After



Power and Environmental Analysis - Preliminary



Tent Configuration

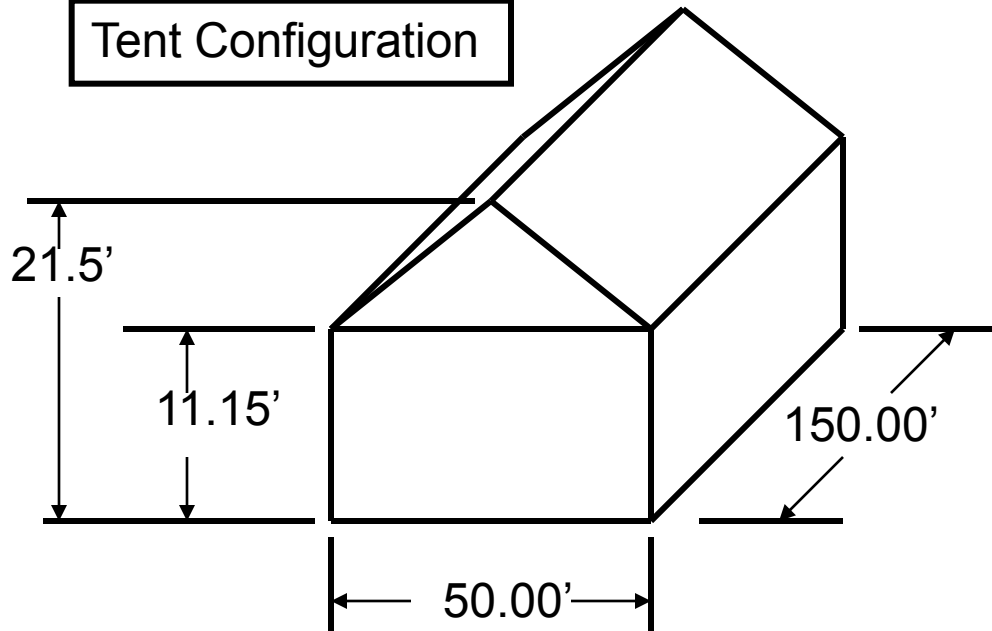

R-Value: A measure of the ability to retard heat flow rather than transmit heat

k-factor: Thermal Conductivity is the measure of a material's ability to transfer heat.

$$R = \frac{\text{Thickness of material (in)}}{\text{k-factor (BTU-in/hr-Sqft- F)}}$$

$$q = k.A \frac{T_{ow} - T_{iw}}{L}$$

- q – Heat Transfer rate
- k – Thermal conductivity
- A – Material Total Area
- T_{ow} – Wall outside temp
- T_{iw} – Wall inside temp
- L – Wall Material Thickness

Tent Parameters	Un-foamed Tent	Foamed Tent	Comments
Tent Surface Area (Roof and Walls)	13,093 Sq Ft	13,093 Sq Ft	Calculated
Tent Air Volume	122,437.5 Cu ft	122,437.5 Cu Ft	Calculated
Tent Wall and Roof Thickness	.018 Inches	3.00 Inches	Unfoamed tent – Measured; Foamed tent – avg. thickness
Tent Material R Value	R1	R5.6 – R8 per inch; Avg: R5.6 /in = R16.8; R6.8/in =R20.4	Base on Contractor = R13 Base on DOE Data = R16.8
Tent Material	PVC - Fabric	Polyisocyanurate (Sprayed Foamed)	Manufacturer: Losberger Intertent GmbH
Estimated Electrical Loads	2.5 kW (1.0 – 1.2, lights; 1.3, mission)	TBD	Tent measured elec. load
Tent personnel Capacity	150	150	Avg occupancy per rotation is approx. 100 people



Data Summary Sheet Preliminary

Description	Set Parameters	Un-foamed Tent (LSA) Measured Data (Winter)	Un-foamed Tent (LSA) Actual Measured Data (Summer; Jul - XXXX)	Foamed Tent Measured Data (Winter)	Foamed Tent Measured Data (Summer)
No. Person	150	Approx. 100 people			
Environmental : (°F) Tent Inside	75 - 85	Day – 72.1 Night – 60.5			
Environmental : (°F) Tent Outside	AR 70 – 38 -25°F to 125°F	Day – 56.6 Night – 45.1			
Environmental : (°F) Inside Wall	TBD	Day – 62.2 Night – 43.4			
Environmental : (°F) Outside Wall	TBD	Day – 63.6 Night - 41.9			
Lights Electrical Loads	TBD	1.0 – 1.2 kW			
Mission Electrical Loads	TBD	1.3 kW			
Tent Material		PVC Fabric			
Tent R Value	TBD	.018 inch thk (single Layer, no insulation) = R1	.018 inch thk (single Layer, no insulation) = R1	3.00 in thk = R13 – 16 per Contractor; R20.4 per DOE Data Sheet	3.00 in thk = R13 – 16 per Contractor; R20.4 per DOE Data Sheet
ECU kW (Max)	TBD	106. 614 kW (Heat)			
Total kW Load	XXXX.XX kW	108.799 kW (Heat + Tent Electrical Load)			
Total Cooling/Heating Load (incl solar)	Based on computer Simulation	Based on computer Simulation			



Expeditionary Power Assessment ECU and Mission Load

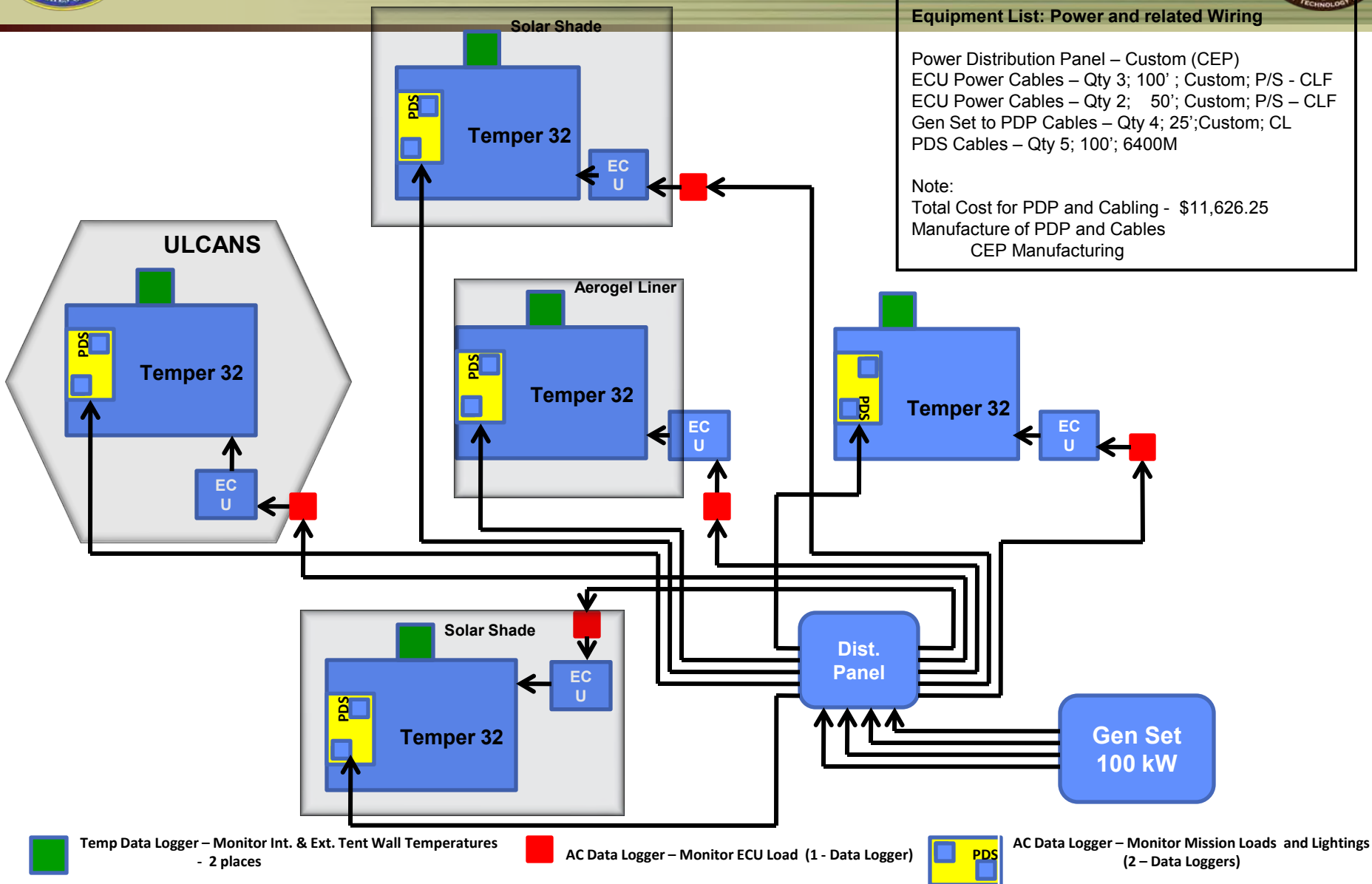



Enduring Power Assessment - Dome Solar and Wind Data



- Dome Renewable power system equipment we are monitoring:

- Renewable Sources at COB King

- 2 solar charge modules
- 2 wind turbines
- 1 generator
- 4 inverters
- 1 battery bank

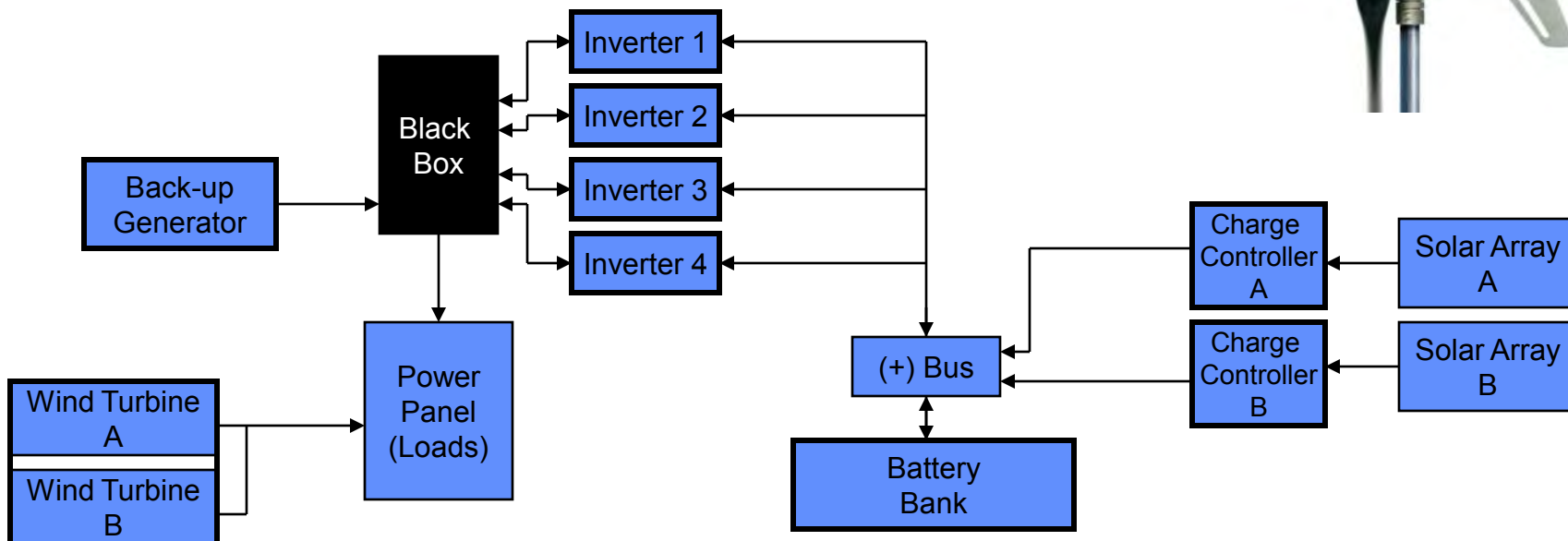



Enduring Power Assessment - Foam ECU and Mission Load

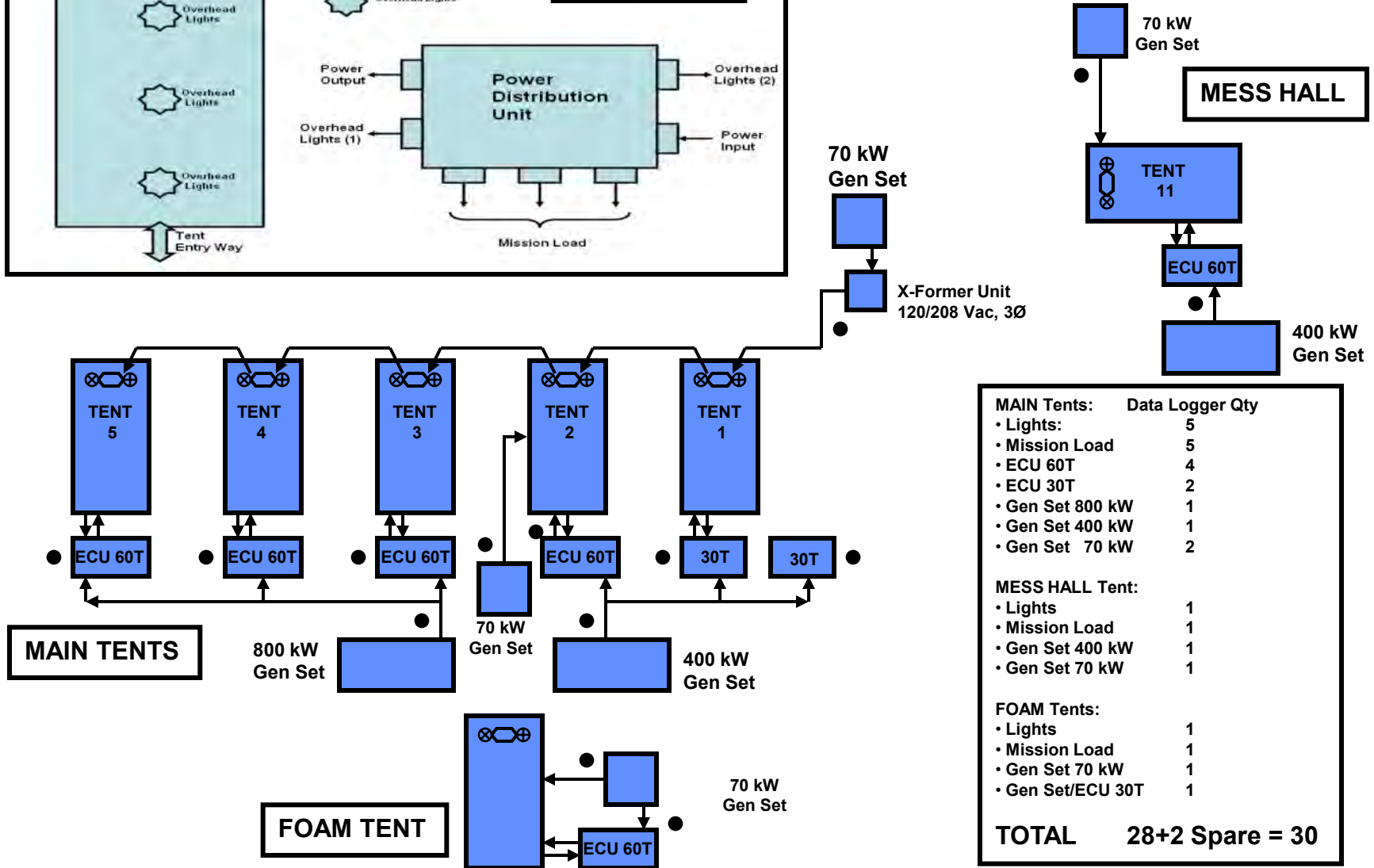
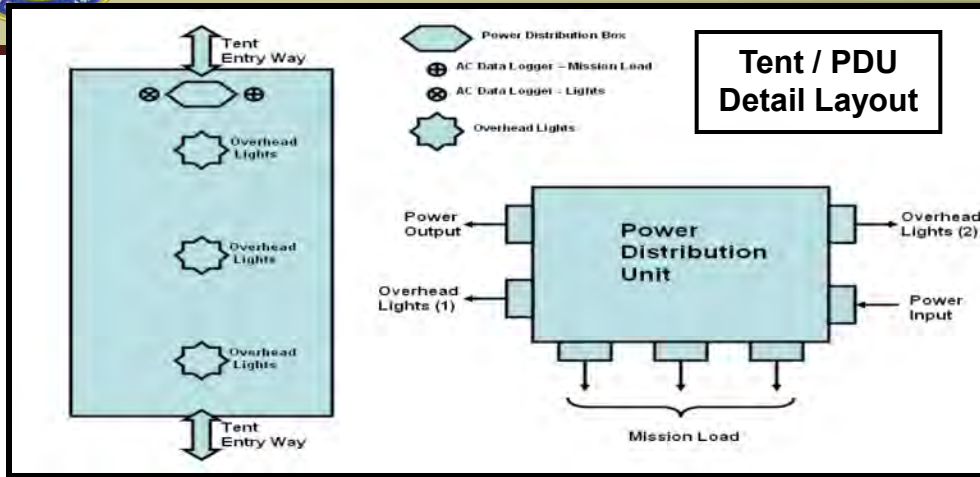

MAIN Tents: Data Logger Qty	
• Lights:	5
• Mission Load	5
• ECU 60T	4
• ECU 30T	2
• Gen Set 800 kW	1
• Gen Set 400 kW	1
• Gen Set 70 kW	2
MESS HALL Tent:	
• Lights	1
• Mission Load	1
• Gen Set 400 kW	1
• Gen Set 70 kW	1
FOAM Tents:	
• Lights	1
• Mission Load	1
• Gen Set 70 kW	1
• Gen Set/ECU 30T	1
TOTAL	28+2 Spare = 30



Enduring Power Assessment - Foam vs Unfoamed ECU and Mission Load

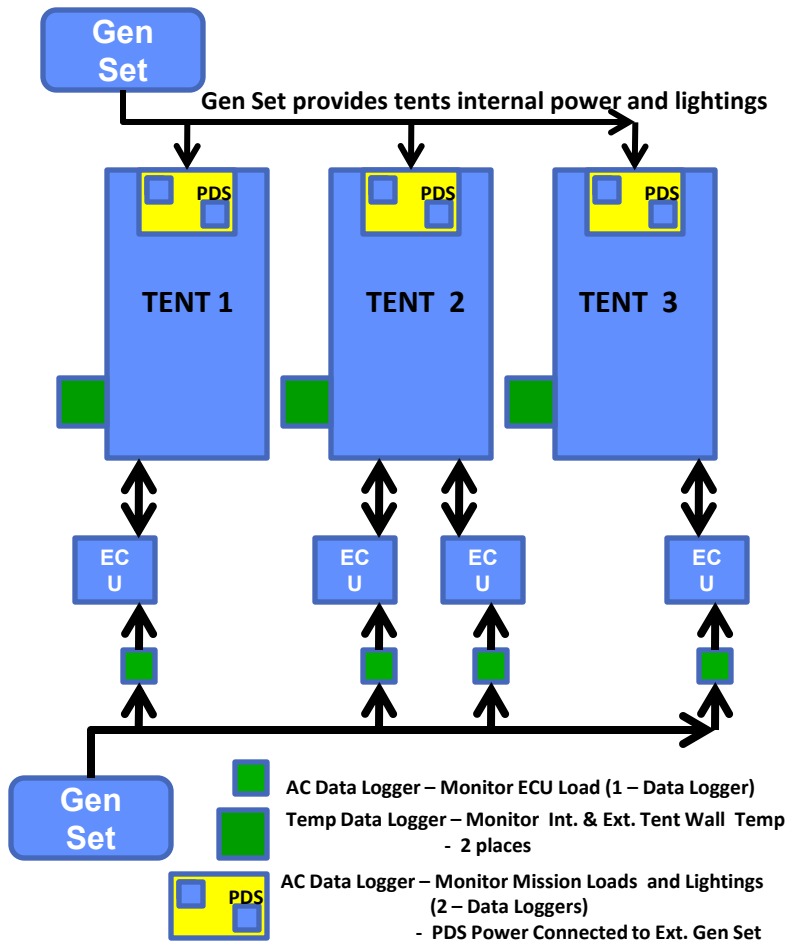

LSA WARRIOR – UNFOAMED TENT

Note: ECUs and CB BOXES are located on permanent concrete pads
Currently ECUs and PDS configuration are not defined

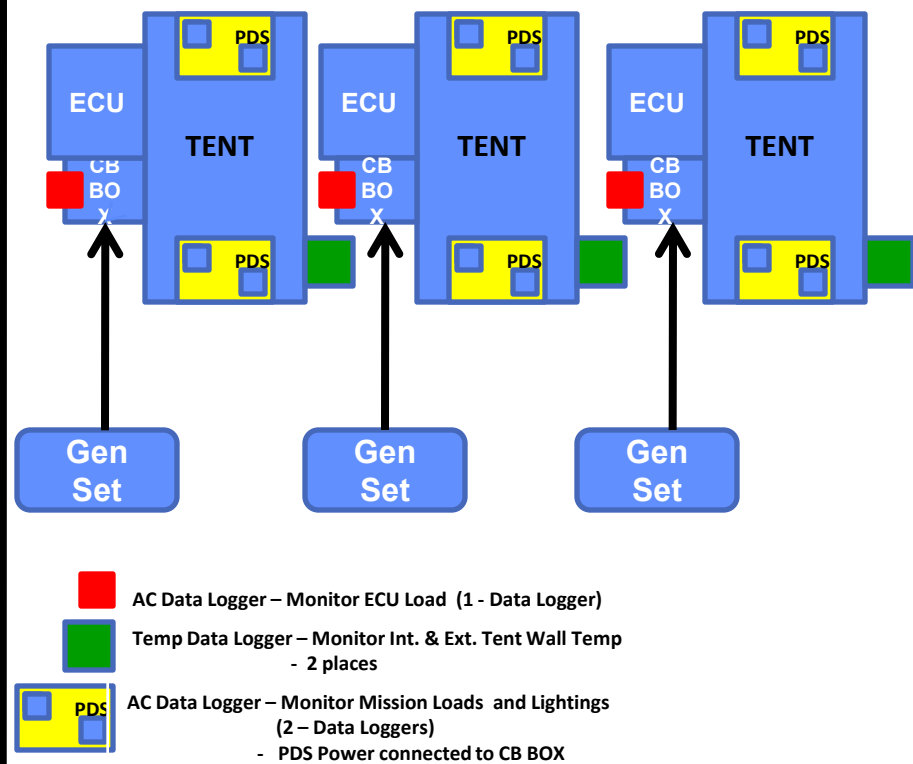

FOB KING/Miami – FOAMED TENT



Foamed and Non Foamed Tent Cooling load Comparison

Set Parameters
75 - 80 F Int Temp
120 -125 F Amb Temp

$T2 - T1 = \Delta T$

Foamed Tent

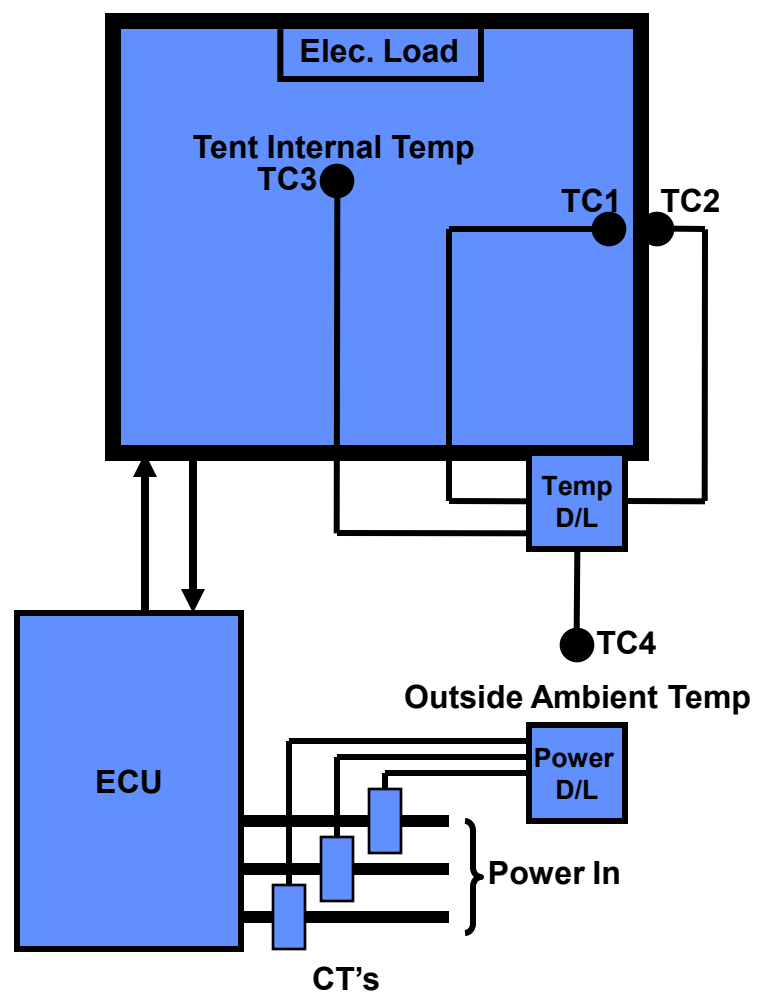

$T2 - T1 = \Delta T$

Non - Foamed Tent

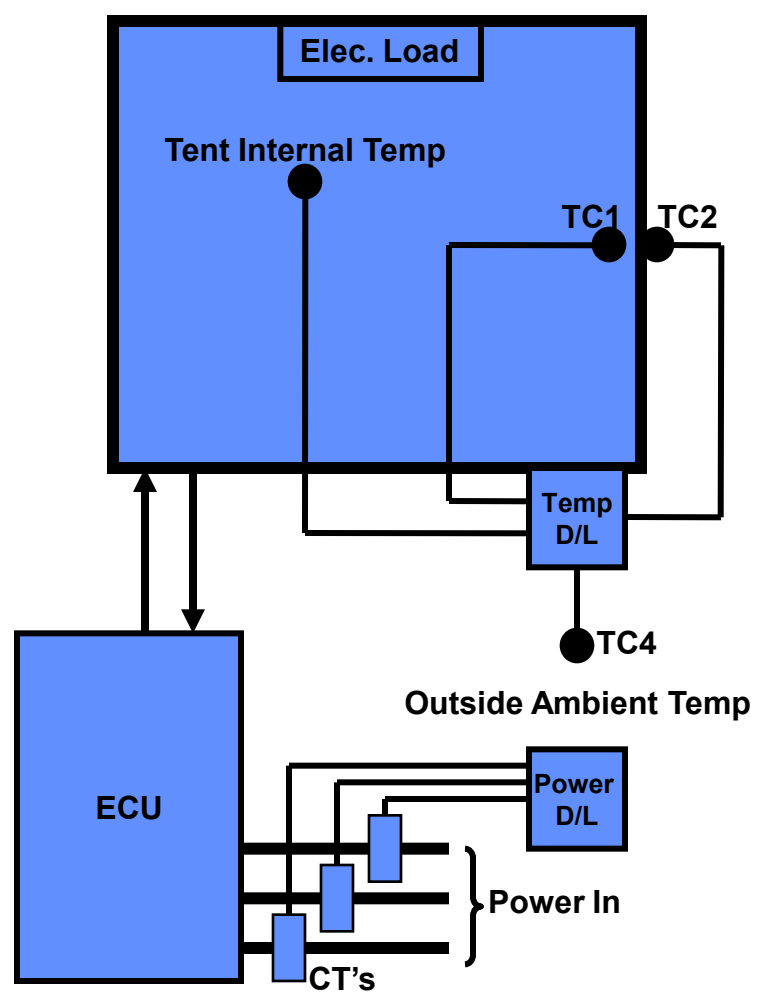



Baseline Testing Equipment – ECU and Mission Loads



Data Logger



**Data Logger location
Outside Tent**

Ambient Temp Thermocouple



Outside



Inside

Tent Wall Thermocouples



Outside Wall



Inside Wall



Baseline Testing Equipment – ECU and Mission Loads



Power Adaptor Box to ECU (20T Unit)



Power Adaptor Box to HTR Pwr. Dist.



Tent Power Dist. Box



ECU Power Adaptor Box



Heater Power Dist. Box



Auxiliary Heater (2 per Tent)



Enduring Power Assessment - Dome Solar and Wind Data



Total kWh vs. Run Time

— Total kWh — Solar — Wind — Generator

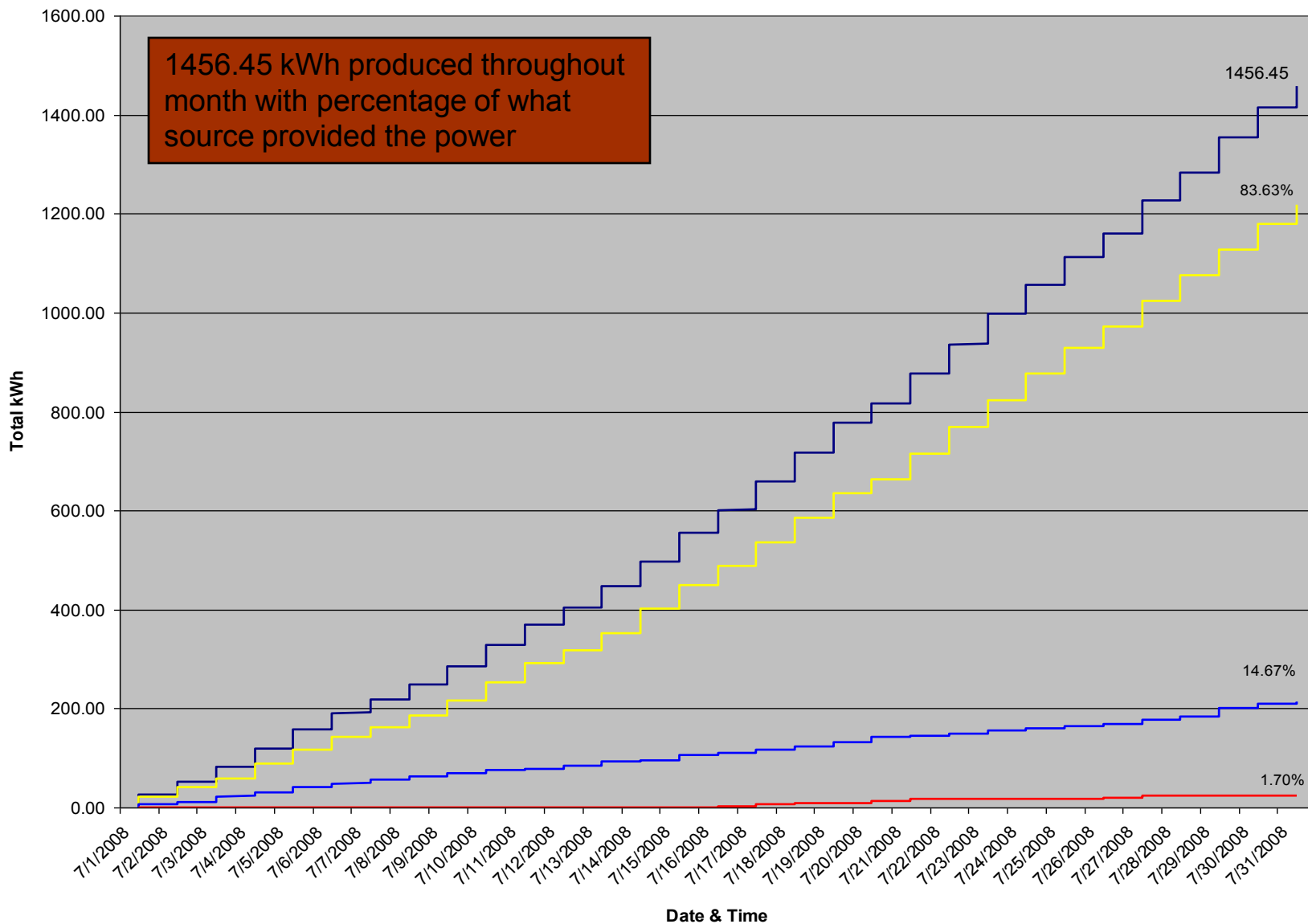



Energy Efficient Structures – Enduring Preliminary Analysis



- Raw data from July 1, 2008 through July 31, 2008
- Data in different supply sources including, wind, solar, and generator
- Characteristics of power available versus time of day
- Energy (kWh) produced from each source throughout the month
- Energy 'lost' by the system because the batteries are full and no demand for the power produced
- Battery voltage versus load & available power
- Load on the inverters versus the system response





Energy Efficient Structures – Enduring Preliminary Analysis

Foamed Tent No. 1 - Inside and Outside Wall Temperature

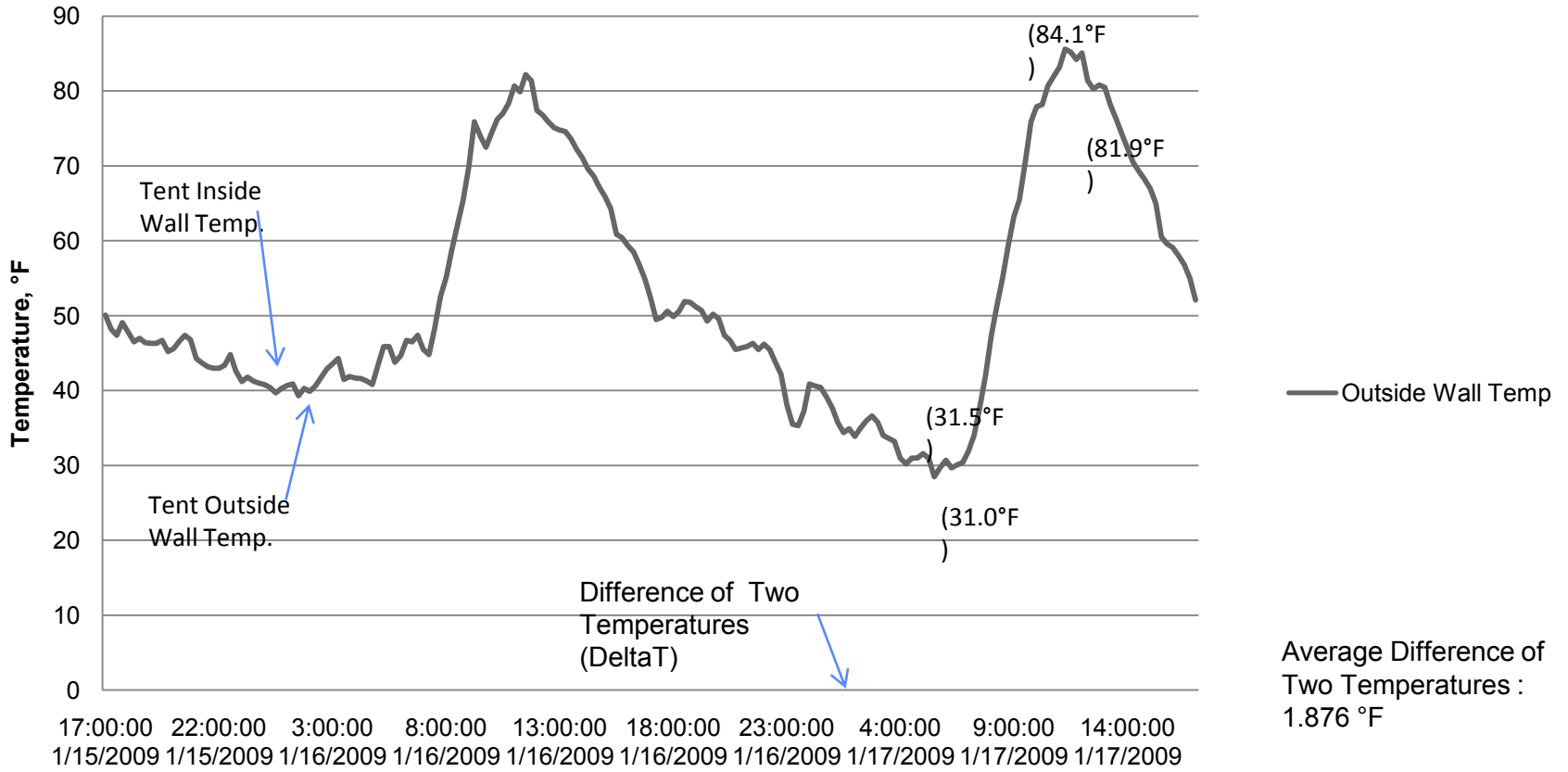



Energy Efficient Structures – Enduring Preliminary Analysis



Tent No. 1 - Inside and Outside Ambient Temperature

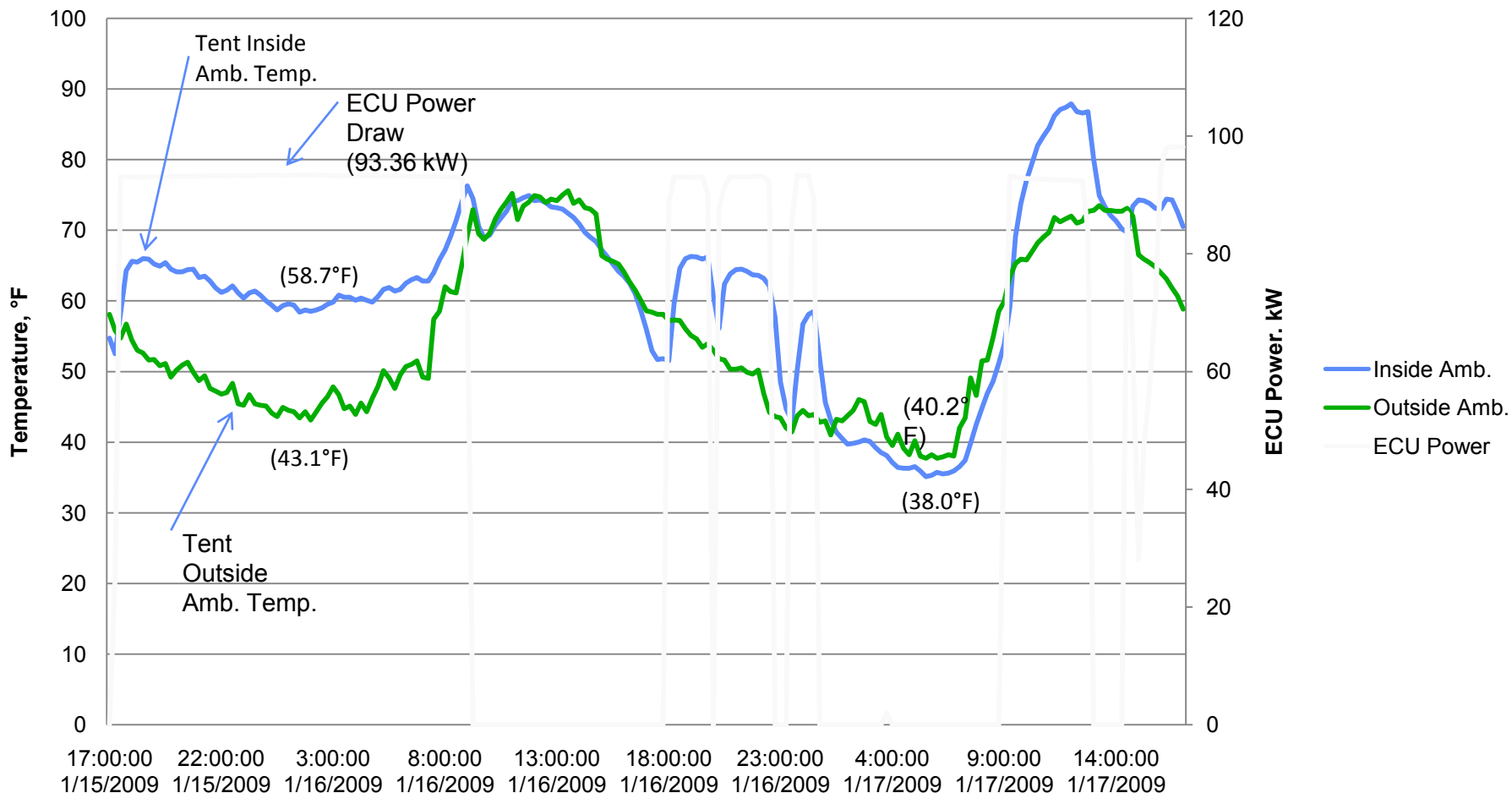



Points of Contact

- **Oversight Executive**
 - Gregory R. Reid, 703.601.2123, Greg.Reid@osd.mil
- **Technical Manager**
 - Ms. Barbara Brygider, 703.615.6774, bbrygider@comcast.net
- **Operational Manager:**
 - Mr. Thomas Smith, 813.827.3287, smithtr@centcom.mil
- **Transition Manager**
 - Mr. Chris Bolton, 703.704.1995, chris.bolton@us.army.mil
- **Data Acquisition/Analysis**
 - Mr. Noel Pleta, 703.704.2148, noel.pleta@us.army.mil