

NUWC-NPT Technical Memorandum 951034

Naval Undersea Warfare Center Division
Newport, Rhode Island

HEARING AID HAVING GREATLY IMPROVED
SIGNAL-TO-ROOMNOISE RATIO

Harry B. Miller
Submarine Sonar Department

19 May 1995

Approved for public release; distribution is unlimited.

Report Documentation Page

Form Approved
OMB No. 0704-0188

Public reporting burden for the collection of information is estimated to average 1 hour per response, including the time for reviewing instructions, searching existing data sources, gathering and maintaining the data needed, and completing and reviewing the collection of information. Send comments regarding this burden estimate or any other aspect of this collection of information, including suggestions for reducing this burden, to Washington Headquarters Services, Directorate for Information Operations and Reports, 1215 Jefferson Davis Highway, Suite 1204, Arlington VA 22202-4302. Respondents should be aware that notwithstanding any other provision of law, no person shall be subject to a penalty for failing to comply with a collection of information if it does not display a currently valid OMB control number.

1. REPORT DATE 19 MAY 1995		2. REPORT TYPE Technical Memo		3. DATES COVERED 19-05-1995 to 19-05-1995	
4. TITLE AND SUBTITLE Hearing Aid Having Greatly Improved Signal-to-Room Noise Ratio				5a. CONTRACT NUMBER	
				5b. GRANT NUMBER	
				5c. PROGRAM ELEMENT NUMBER	
6. AUTHOR(S) Harry Miller				5d. PROJECT NUMBER	
				5e. TASK NUMBER	
				5f. WORK UNIT NUMBER	
7. PERFORMING ORGANIZATION NAME(S) AND ADDRESS(ES) Naval Undersea Warfare Center Division, Newport, RI, 02841				8. PERFORMING ORGANIZATION REPORT NUMBER TM 951034	
9. SPONSORING/MONITORING AGENCY NAME(S) AND ADDRESS(ES)				10. SPONSOR/MONITOR'S ACRONYM(S)	
				11. SPONSOR/MONITOR'S REPORT NUMBER(S)	
12. DISTRIBUTION/AVAILABILITY STATEMENT Approved for public release; distribution unlimited					
13. SUPPLEMENTARY NOTES NUWC2015					
14. ABSTRACT The objective of this project is to replace existing hearing aid (HA) designs with one incorporating an adaptive noise-reduction process, in order to reduce room noise received through a microphone to be called the Primary sensor. The Primary sensor is paired with a second, or Reference, sensor which feeds into a bank of filters called a spectral equalizer. Both sensors then feed into an adaptive filter which reduces the noise but retains the Target Signal.					
15. SUBJECT TERMS Hearing Aid Design; noise-reduction					
16. SECURITY CLASSIFICATION OF:			17. LIMITATION OF ABSTRACT	18. NUMBER OF PAGES	19a. NAME OF RESPONSIBLE PERSON
a. REPORT unclassified	b. ABSTRACT unclassified	c. THIS PAGE unclassified			

ABSTRACT

The objective of this project is to replace existing hearing aid (HA) designs with one incorporating an adaptive noise-reduction process, in order to reduce room noise received through a microphone to be called the Primary sensor. The Primary sensor is paired with a second, or Reference, sensor which feeds into a bank of filters called a spectral equalizer. Both sensors then feed into an adaptive filter which reduces the noise but retains the Target Signal.

ADMINISTRATIVE INFORMATION

This document was funded under the B&P Dual Use Program.

ACKNOWLEDGMENTS

The author gratefully acknowledges the support of R. Nadolink and R. LaPlante, and the technical assistance of R. Janus.

LIST OF ILLUSTRATIONS

Figure		Page
1	S/N = 0 dB, With Six Tones-Plus-Random Noise (Upper Curve) and the Six Tones Alone (Lower Curve)	7
2	S/N = +10 dB, With Six Tones-Plus-Random Noise (Upper Curve) and the Six Tones Alone (Lower Curve)	9
3	Pattern of a Free-Field Cardioid Element for $d/\lambda \ll 0.5$	11
4	Pattern in Decibels of a Free-Field Doublet Element for $d/\lambda = 0.875$	12
5	Dummy Head of Polystyrene Foam With Cardioid Microphones on the Front Bar of a Pair of Eyeglasses	13
6	Horizontal Radiation Patterns for an Array of Two Antennas Fed With Equal Magnitude Currents	14
7	Interferometer Pattern of Two Elements Spaced 4 Inches Apart. Frequency = 4000 Hz, $d/\lambda = 1.23$	15
8	Interferometer Pattern of Two Elements Spaced 4 Inches Apart. Frequency = 1000 Hz, $d/\lambda = 0.31$	16
9	Interferometer Pattern of Two Elements Spaced 4 Inches Apart. Frequency = 2000 Hz, $d/\lambda = 0.62$	17
10	Bank of Digital Comb Filters, Frequency Range: 90 Hz to 4000 Hz	19
11	Primary Sensor Pattern at 1000 Hz (Microphone Next to Manikin)	21

HEARING AID HAVING GREATLY IMPROVED SIGNAL-TO-ROOMNOISE RATIO

BACKGROUND

The objective of this project is to replace existing hearing aid designs with one incorporating an adaptive noise-reduction process, in order to reduce room noise received through a microphone to be called the Primary sensor. The Primary sensor is paired with a second, or Reference, sensor which feeds into a bank of filters called a spectral equalizer. Both sensor systems then feed into an adaptive filter which acts to reduce the noise, but retain the target signal.

The approach to be followed is to use the insight gained from our work on noise-reduction of electroacoustically received hull noise of ships, and to modify the method to be applicable to reduction of room noise as received by a hearing aid. The ship noise project was reported on in NUWC-NPT Technical Report 10,625, issued 2 June 1994.¹

Specifically, a semi-active system will be used that can quiet the noise in a hearing aid system. The noise is picked up by a primary microphone receiving both target signals and noise in a noisy room, and by a reference microphone receiving, ideally, only noise. This is called a target-free sensor. The theory we use, which goes beyond Widrow's writing,¹ was developed by Benthien et al. and is given in Ref. 1. The Reference sensor's output is subtracted, dynamically, from the Primary sensor's output, and ideally only the target signal remains. In practice, although the noise may easily be reduced by 20 dB, the target signal is also reduced, perhaps by 10 dB or more. So the overall signal-to-noise (S/N) improvement will probably be less than 10 dB.

In the ship-quieting problem, two criteria emerged from theory and were confirmed by experiment:

1. There must be a high coherence value C between noise in the Reference sensor (N_R) and noise in the Primary sensor (N_P). Ideally, the coherence magnitude-squared C should be greater than 0.90.

2. The target signal-freeness r of the reference sensor R should have a value of at least -6 dB. When r is -6 dB, the target signal can survive, while the noises N_P and N_R cancel each other.

The theory we use was developed by Benthien et al. in part 6 of NUWC-NPT TR 10,625. Some ship-situation examples, using this theory, are also given in Ref. 1.

Benthien's equation is repeated here:

$$\text{Improvement} = \frac{1 + C_N r - 2 \sqrt{C_S C_N r} \cdot \cos \delta}{1 - C_N} \quad (1)$$

This is discussed on page 34 et seq of volume 1 of Ref. 1. Note that:

1. C_N is the magnitude-squared coherence of the noise between the two sensors, P and R,
2. C_S is the magnitude-squared coherence of the signal between the two sensors, P and R,
3. r is the signal-freeness factor of the R sensor and should be considerably < 1 , and
4. δ is the phase angle difference between the two coherences C_S and C_N .

It is possible to build a reference sensor R having a notch region for both signal and noise in a given angular region. When the hearing aid wearer faces the speaker (talker) his reference sensor appears to be target-free with respect to the direct signal, but target signal can nevertheless leak into the reference sensor (sideways) due to reflection from a wall, at angles such as 40° or 320° . This leakage signal will then try to cancel the target signal itself. This is one of the problems arising in the adaptive noise-canceling method when applied to hearing aids.

EXPERIMENTAL

In the first set of experiments, a room's tolerable level of S/N, i.e., suitable for a hearing aid wearer, was investigated. Two levels of S/N were generated using six tones simultaneously: 250, 500, 1000, 2000, 4000, and 8000 Hz. Figure 1 shows the 0 dB S/N case with six tones-plus-random noise (upper curve) and the six tones alone (lower curve). Figure 2 shows a similar

situation, with the S/N increased by 10 dB. If a noisy restaurant causes the S/N to be 0 dB as shown in figure 1, and if the apparent noise level is electronically reduced by 10 dB, the improved S/N ratio (as seen in the upper curve of figure 2), is still difficult for a listener, but probably tolerable. A restaurant where the S/N is effectively 0 dB will usually be avoided a second time by a person wearing a hearing aid. The hearing aid system under investigation would probably be able to increase the S/N ratio by 10 dB or more and thus make many restaurant experiences tolerable which were formerly intolerable.

The system requires two sensors, a primary sensor P and a reference sensor R. The P sensor picks up the target T (or signal) plus the noise N. Ideally, the noise should be isotropic. The P sensor can have an omnidirectional pattern or preferably be slightly directional, meaning e.g. a dull cardioid pattern (which is the best that a miniature microphone can provide). A free-field cardioid pattern, not too representative of the "cardioid" pattern from the microphone seated on the human head, is shown in figure 3. This pattern will not focus sharply on the person speaking, unfortunately, but will reduce the noise picked up from the sides and the rear.

The R sensor that we are striving for should, first of all, have a notch at 0°. This could be accomplished by a cardioid microphone firing backward; or by a figure-of-eight microphone oriented suitably. When an R sensor with a notch at 0° was first tested, briefly, in a small "live room," in conjunction with an adaptive filter system, the noise was indeed reduced considerably (> 10 dB), but the target signal was also greatly reduced. The reason is, the signal was bouncing off the nearby wall and entering the R sensor in the angular region 0°– 90°– 180°. This phenomenon did not occur in the ship's hull-noise problem, no sidewalls being present in the ocean.

This is a major problem in using adaptive noise canceling in a hearing aid system. The solution we have chosen is to use a modified doublet with a pattern somewhat similar to that of a free-field doublet with d/λ or $\alpha/\lambda \simeq 0.875$ (see figure 4).

The experimental realization of this desirable pattern was worked on in the large anechoic chamber in building 80. Two arrays of cardioid microphones were placed on the front bar of an eyeglass pair. The eyeglass was mounted on a dummy head of polystyrene foam, as shown in figure 5. The dummy should have been, ideally, the KEMAR manikin made by the Knowles Electronics Co. of Chicago. This would have had a more realistic acoustic impedance. In any event, the free-field directivity patterns shown in figure 6 are merely distant relatives of the patterns obtainable in the presence of a finite baffle (the polystyrene dummy head). Computed

patterns on a finite baffle would have required an expensive detour using a special computer. This was not possible and so the experimental approach alone was used.

A left array and a right array, wired in phase opposition to form a notch, gave poorer patterns than one left element and one right element (reversed). The resulting interferometer pattern is shown in figure 7. Two cardioid elements were used, facing sideways, but two omni elements would have given almost the same results. The two elements were 4 inches apart. The frequency was 4000 Hz. Velocity of sound in air is 332 m/sec or 13000 in./sec, and so $\lambda \simeq 3.25$ inches. Then $d/\lambda = 1.23$. The pattern corresponds fairly well to that of figure 6, where d/λ is 0.875. The baffle is mainly responsible for the discrepancies, including the fact that an experimental d/λ of 1.23 correlates best with a theoretical d/λ of 0.875.

This reference sensor pattern says that the two rabbit ears are 10 dB higher than everything outside the region 50° to 310° . Hence, the noise level into the adaptive filter should be controllable primarily by the two lobes at 30° and 330° and hence any target signal coming in at, say, a 50° angle (reflected from a wall) will seem to be 10 dB weaker than equivalent noise coming in at 30° and 330° . So the noise will control the adapting of the adaptive filter, which is what we desire. Hence, this reference sensor pattern may well be a target-free pattern.

An interferometer pattern taken at 1000 Hz is shown in figure 8. The λ is now 13 inches and $d/\lambda \simeq 0.31$. The pattern corresponds roughly to the $d/\lambda \simeq 0.5$ pattern of figure 6. Note that the long λ ignores the baffle by diffracting around it, thus approximating the free-field pattern. For these lower frequencies or longer λ 's it is proposed to use a second pair of left and right elements situated 4 inches back on each eyeglass temple. The deep notch would still occur at 0° and the longer path length of about 13 inches from left temple to right temple should produce a pattern more like that of figure 7.

A third pair of left and right elements might be used for $f = 2000$ Hz ($\lambda \simeq 6.5$). These would be situated on the two temples, just below the hinge, giving a path length of about 7 inches. This should produce a pattern similar to figure 7. (The present experimental pattern is shown in figure 9).

A bank of digital comb filters, readily available as part of the required signal-processing hardware of an adaptive filter, can easily direct each filtered band into the correct pair of microphone elements. Figure 10 shows a filter bank, i.e., an equalizer, which has been in use at NUWC DIVNPT for some time. It provides independent control of the amplitude (red curve) and

phase (blue curve) of 18 bands from 90 Hz to 4000 Hz. The bands are of programmable width. On a logarithmic frequency scale, figure 10 would show all bands having approximately equal width.

A Primary sensor pattern taken at 1000 Hz, the single microphone being close to the forehead of the manikin, is shown in figure 11. Diffraction around the baffle reduces the response noticeably in the rear and at the sides.

An existing portable adaptive filter, driven by a 12-volt battery, is now available. It weighs 2 lbs. and has dimensions of 6" x 4" x 1". This unit is now being further miniaturized by Adaptive Digital Systems, Inc. of Irvine, CA. The existing unit is called Micro TDAP 202. When connected by a radio link to the microphones on an eyeglass frame (already being done by some European companies), the complete noise-canceling system could be in operation.

0° S/N = 0 dB
100 msec PULSES

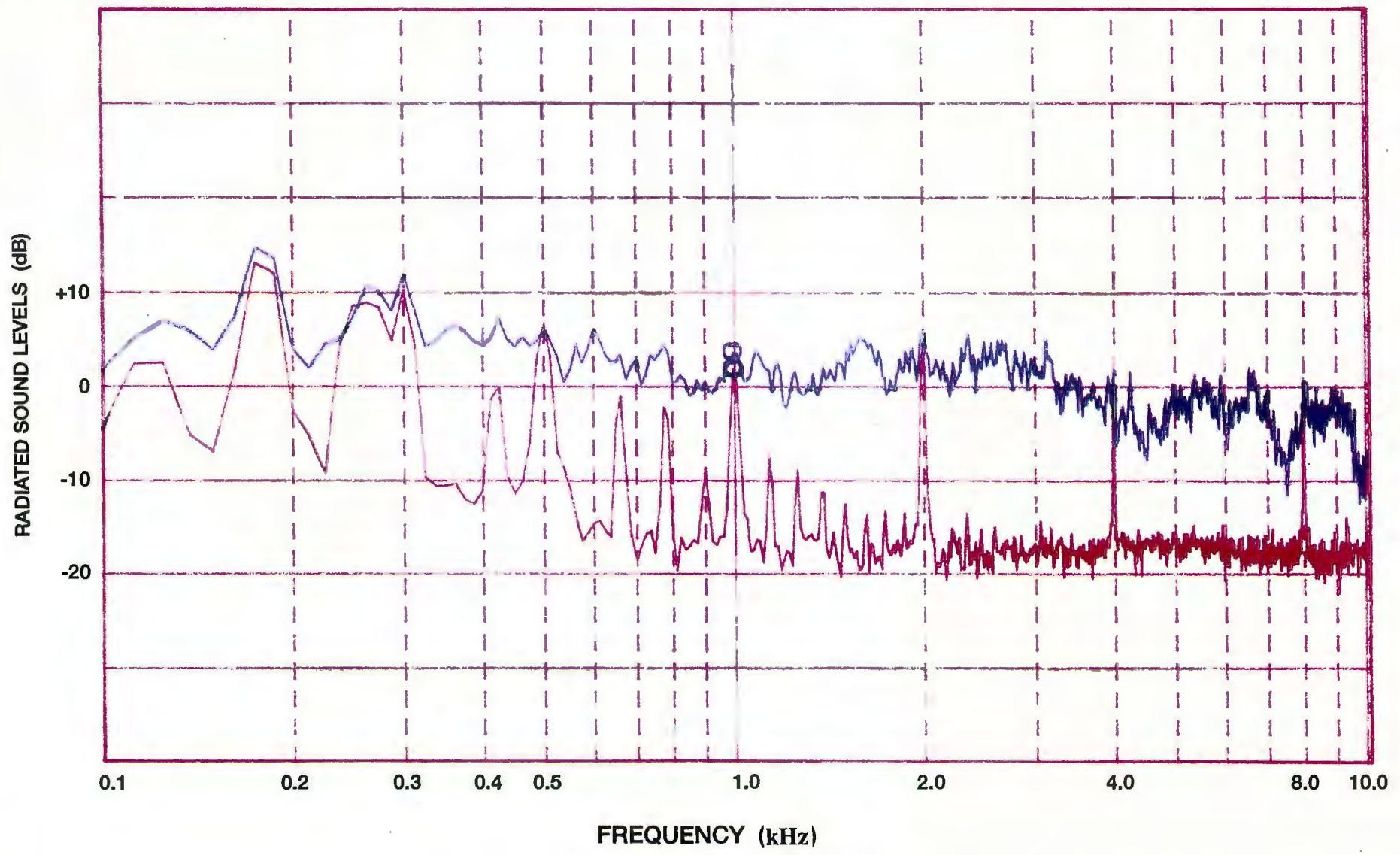

Figure 1. S/N = 0 dB, With Six Tones-Plus-Random Noise (Upper Curve) and the Six Tones Alone (Lower Curve)

0° S/N = +10 dB
100 msec PULSES

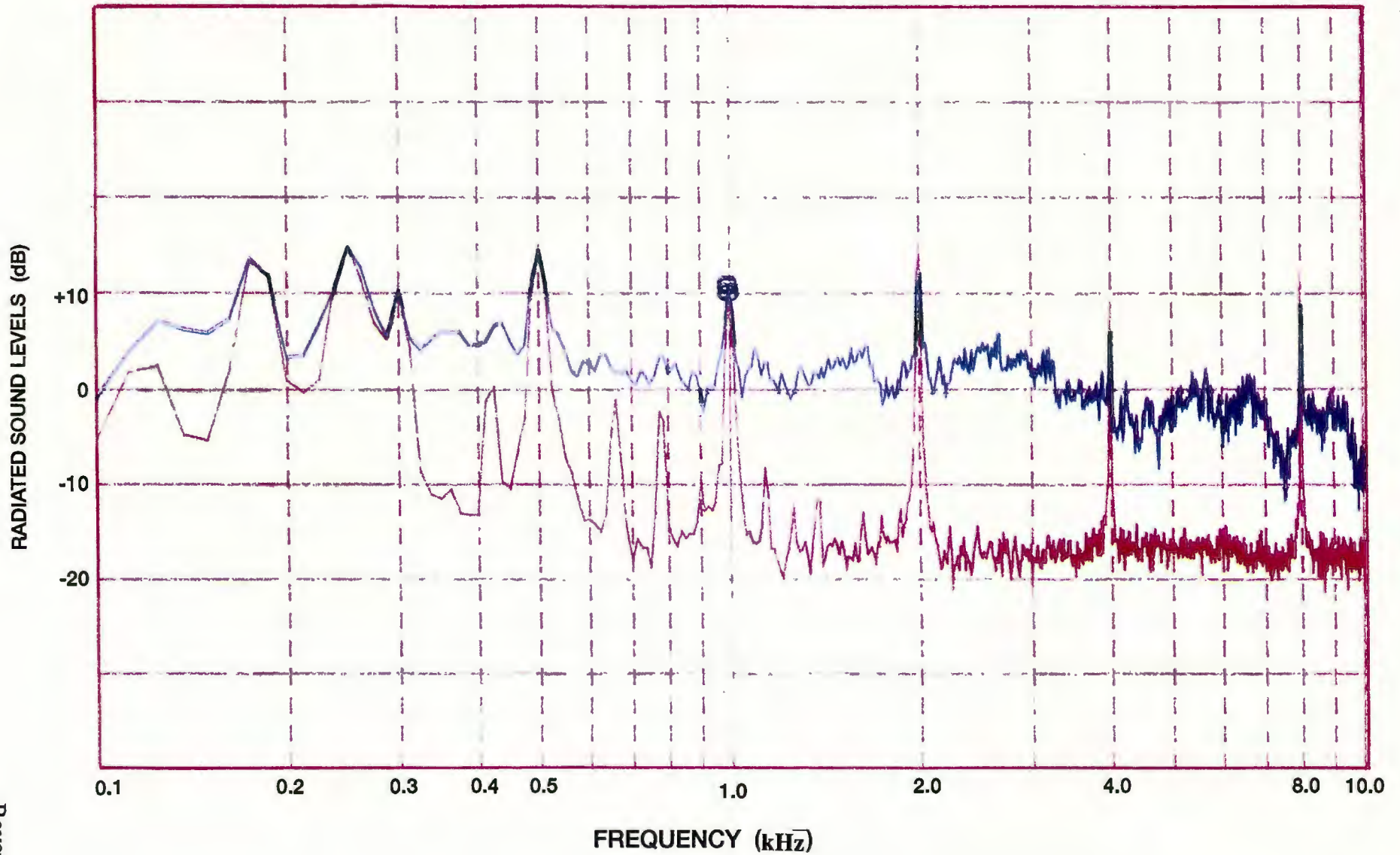

Figure 2. S/N = +10 dB, With Six Tones-Plus-Random Noise (Upper Curve)
and Six Tones Alone (Lower Curve)

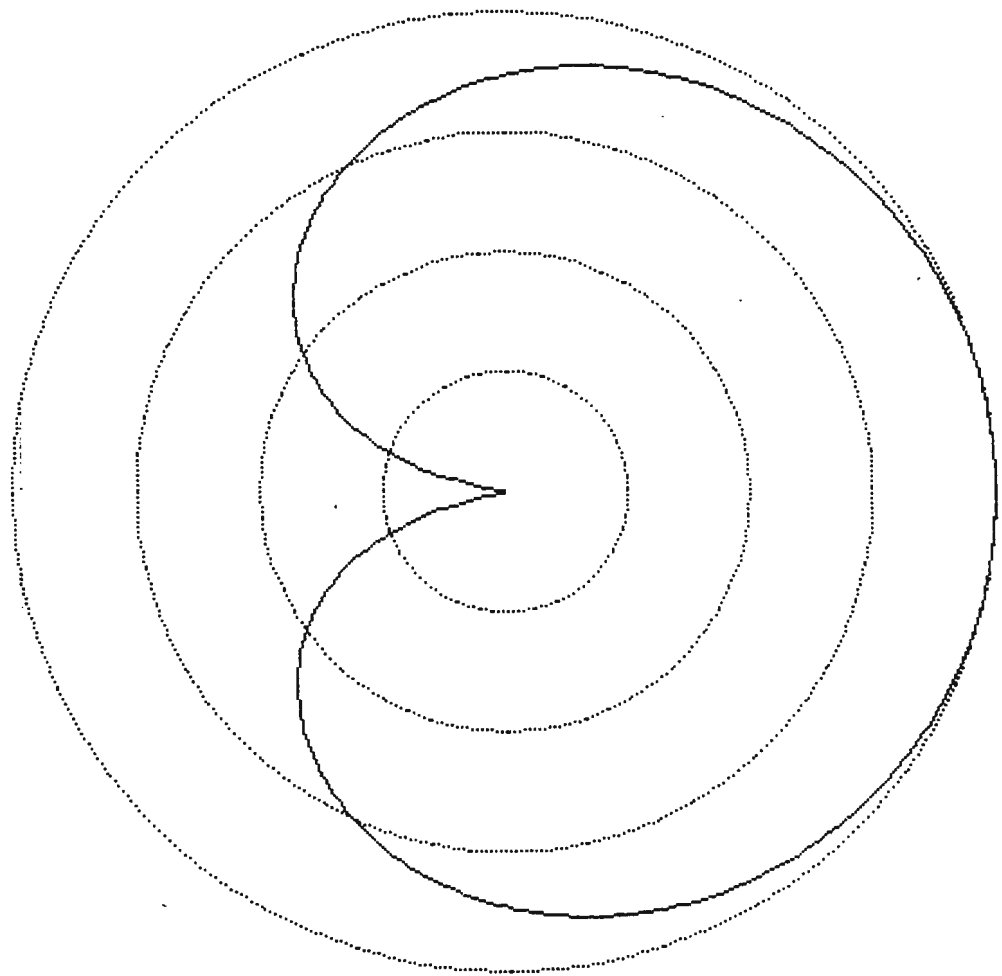

Figure 3. Pattern of a Free-Field Cardioid Element for $d/\lambda \ll 0.5$

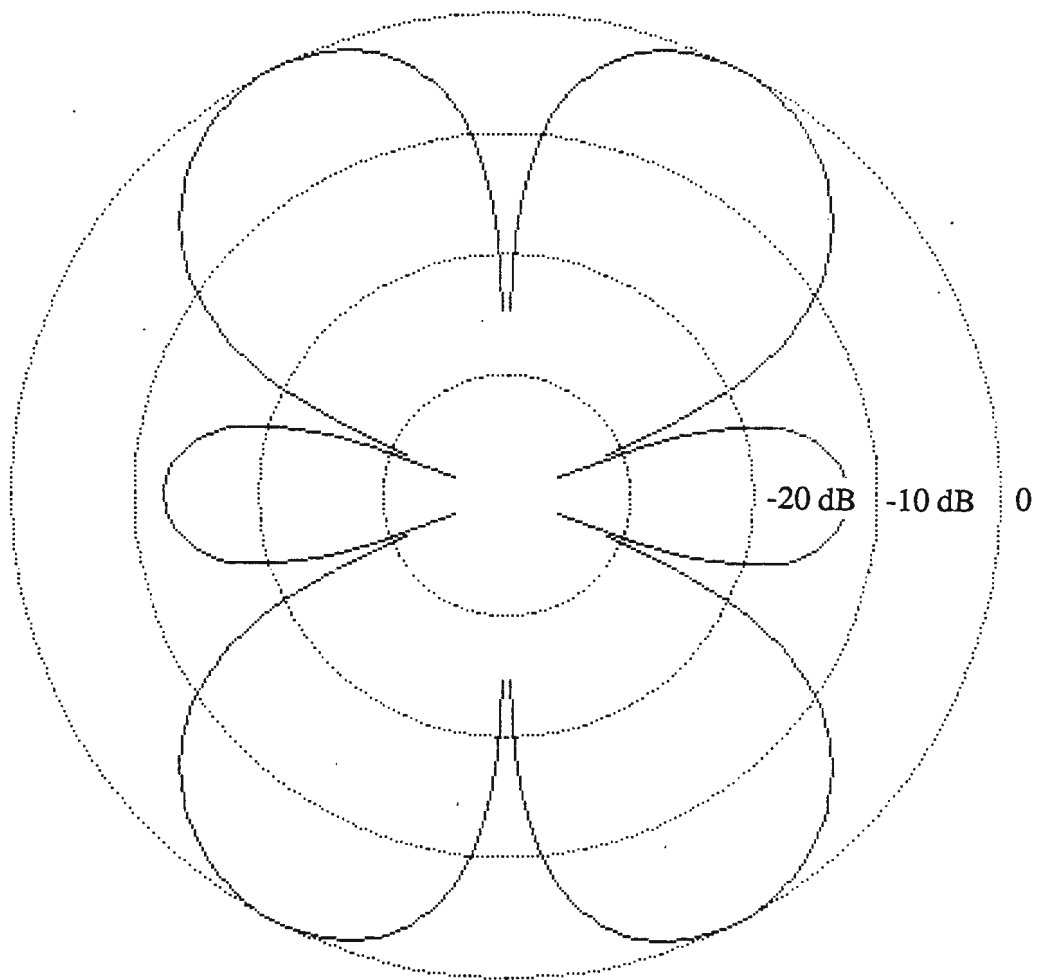

Figure 4. Pattern in Decibels of a Free-Field Doublet Element for $d/\lambda = 0.875$

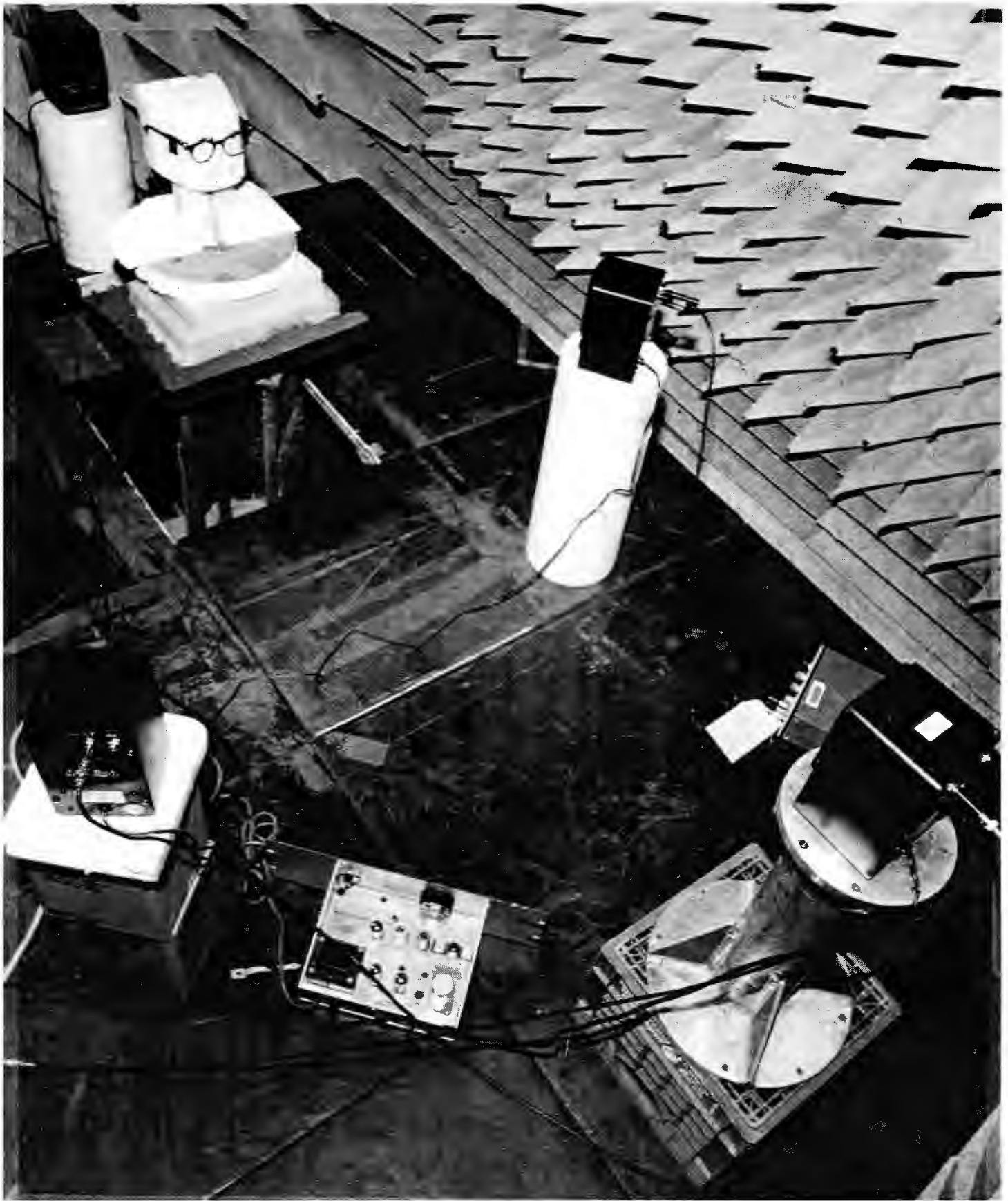

Figure 5. Dummy Head of Polystyrene Foam With Cardioid Microphones on the Front Bar of a Pair of Eyeglasses

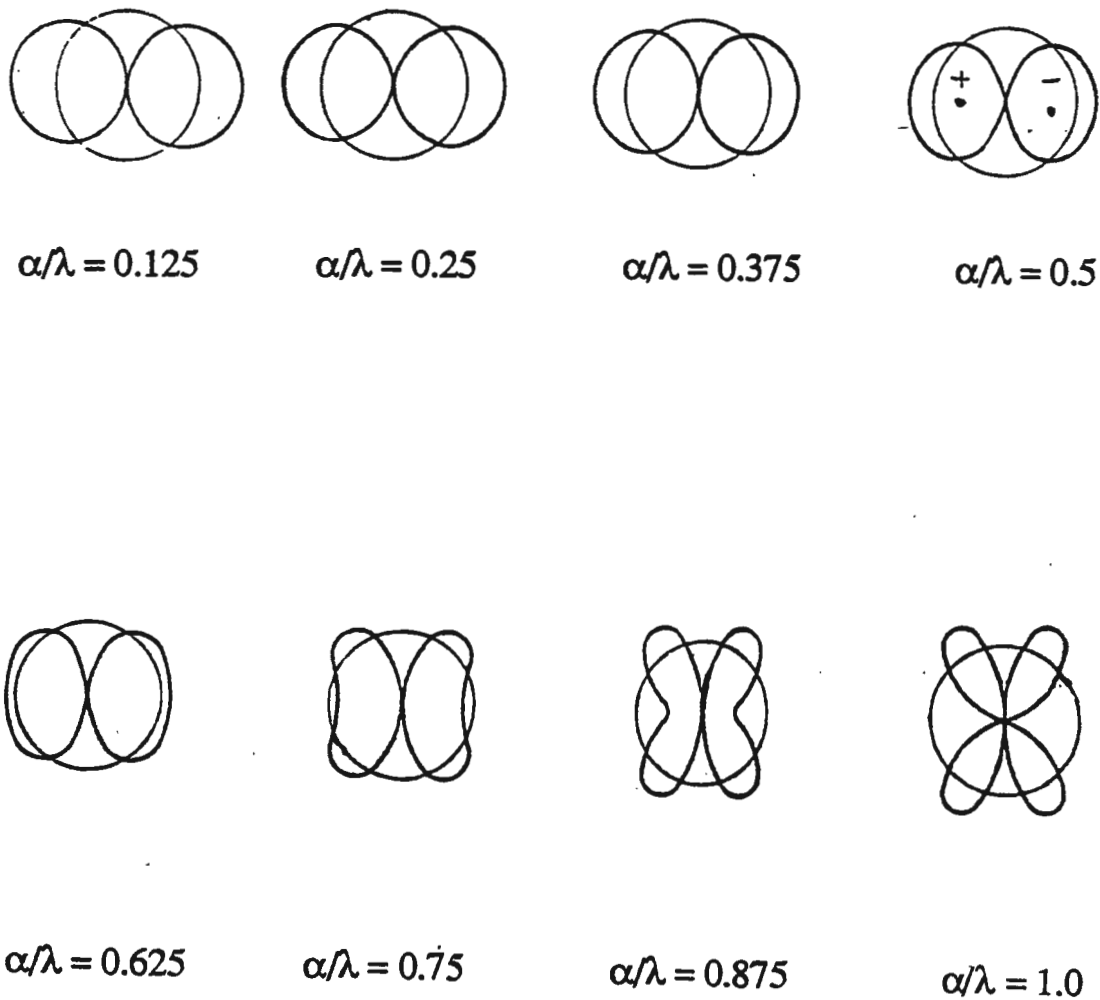

Figure 6. Horizontal Radiation Patterns for an Array of Two Antennas Fed With Equal Magnitude Currents (These patterns are shown in linear units (e.g. volts) not decibels. All other patterns are given in decibels).

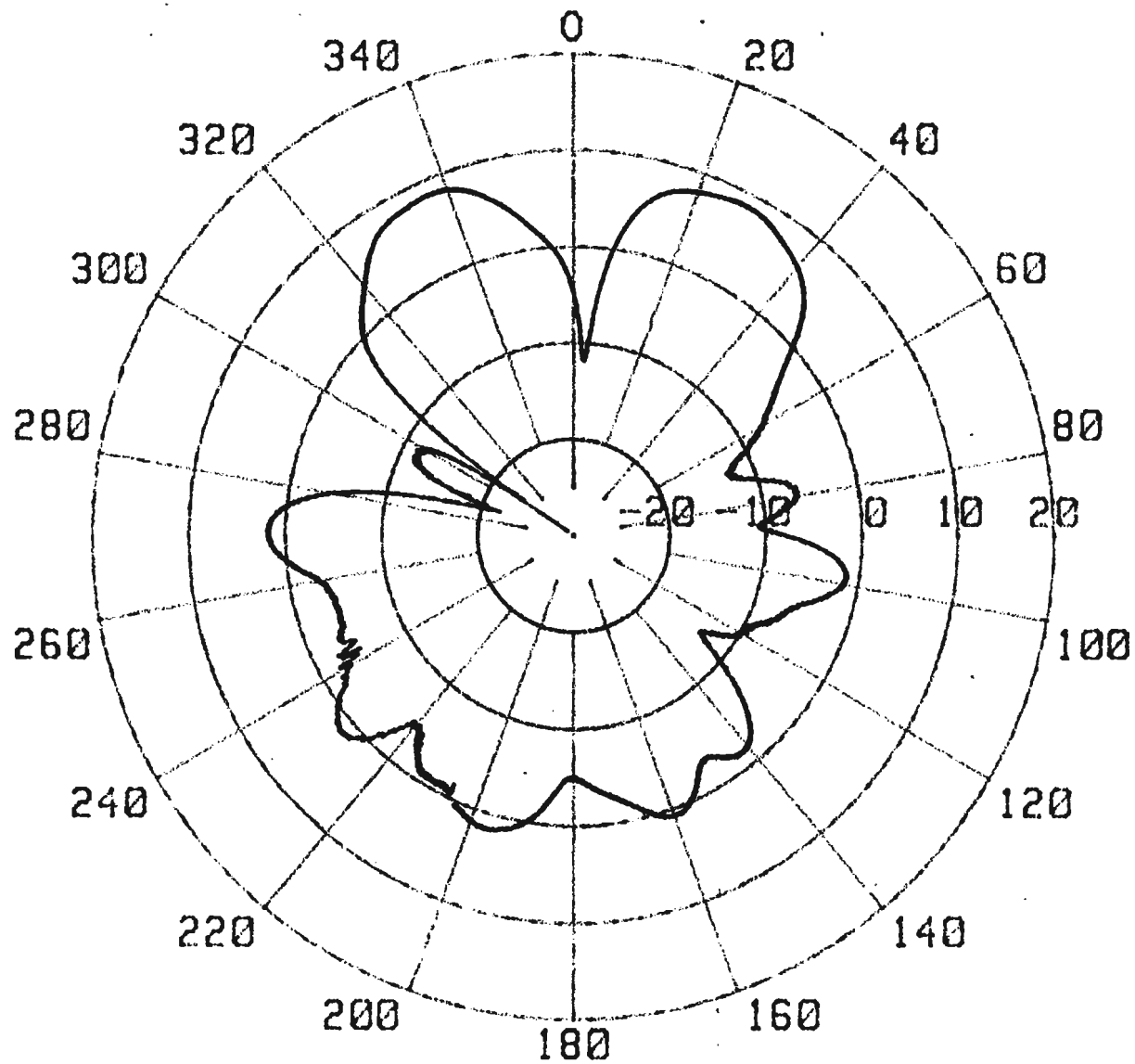

Figure 7. Interferometer Pattern of Two Elements Spaced 4 Inches Apart.
 Frequency = 4000 Hz, $d/\lambda = 1.23$

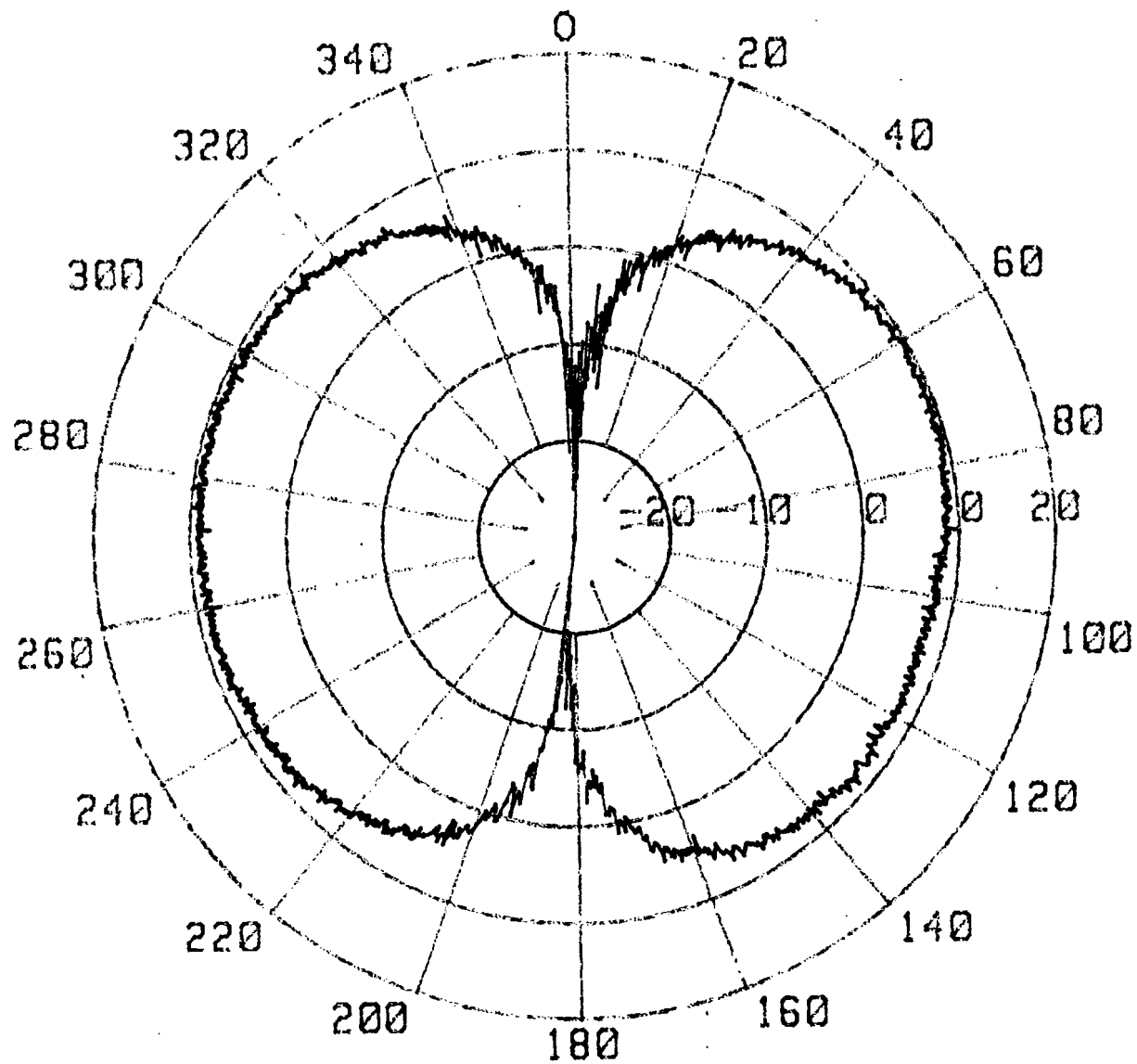

Figure 8. Interferometer Pattern of Two Elements Spaced 4 Inches Apart.
Frequency = 1000 Hz, $d/\lambda = 0.31$

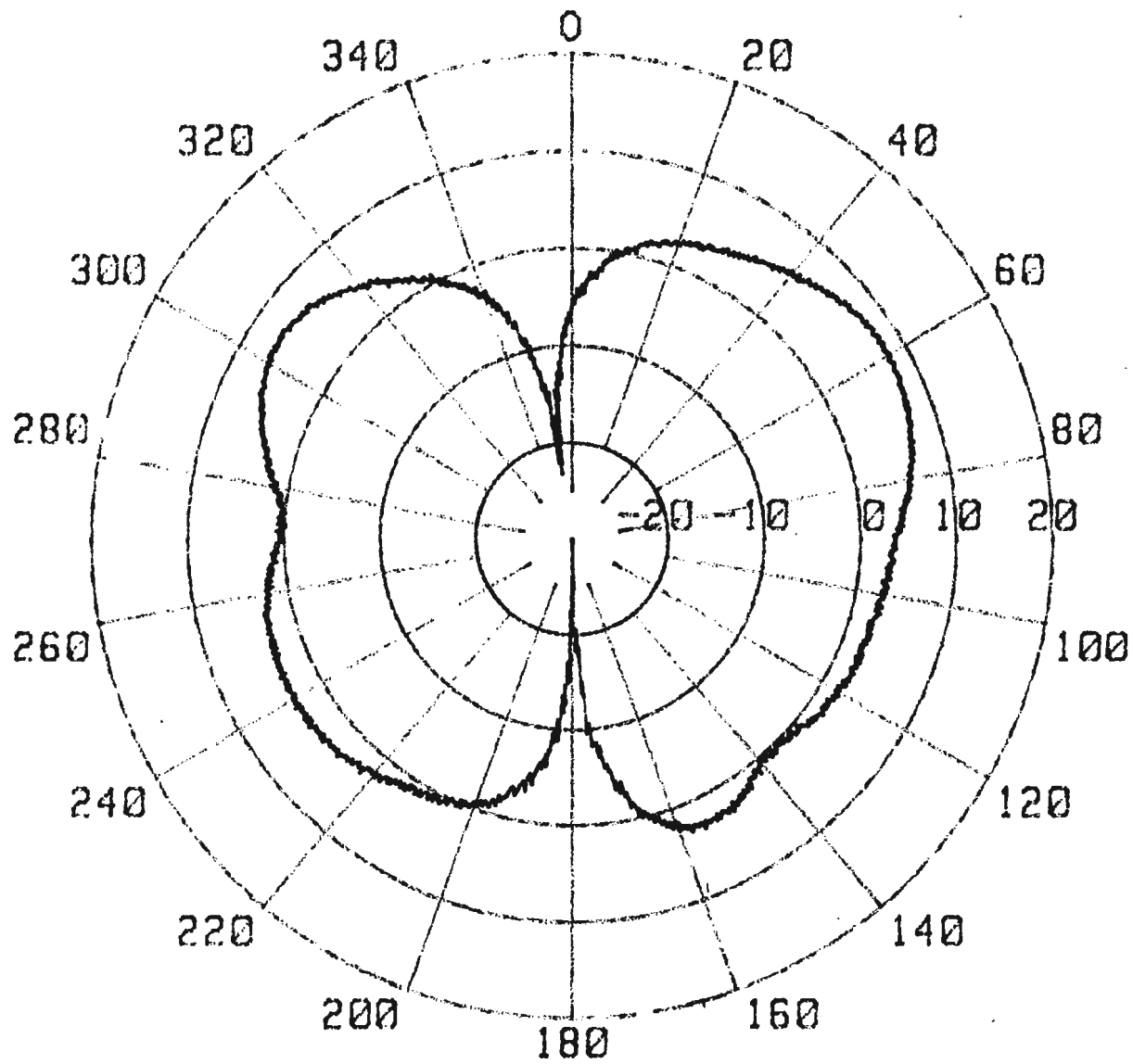

Figure 9. Interferometer Pattern of Two Elements Spaced 4 Inches Apart.
 Frequency = 2000 Hz, $d/\lambda = 0.62$

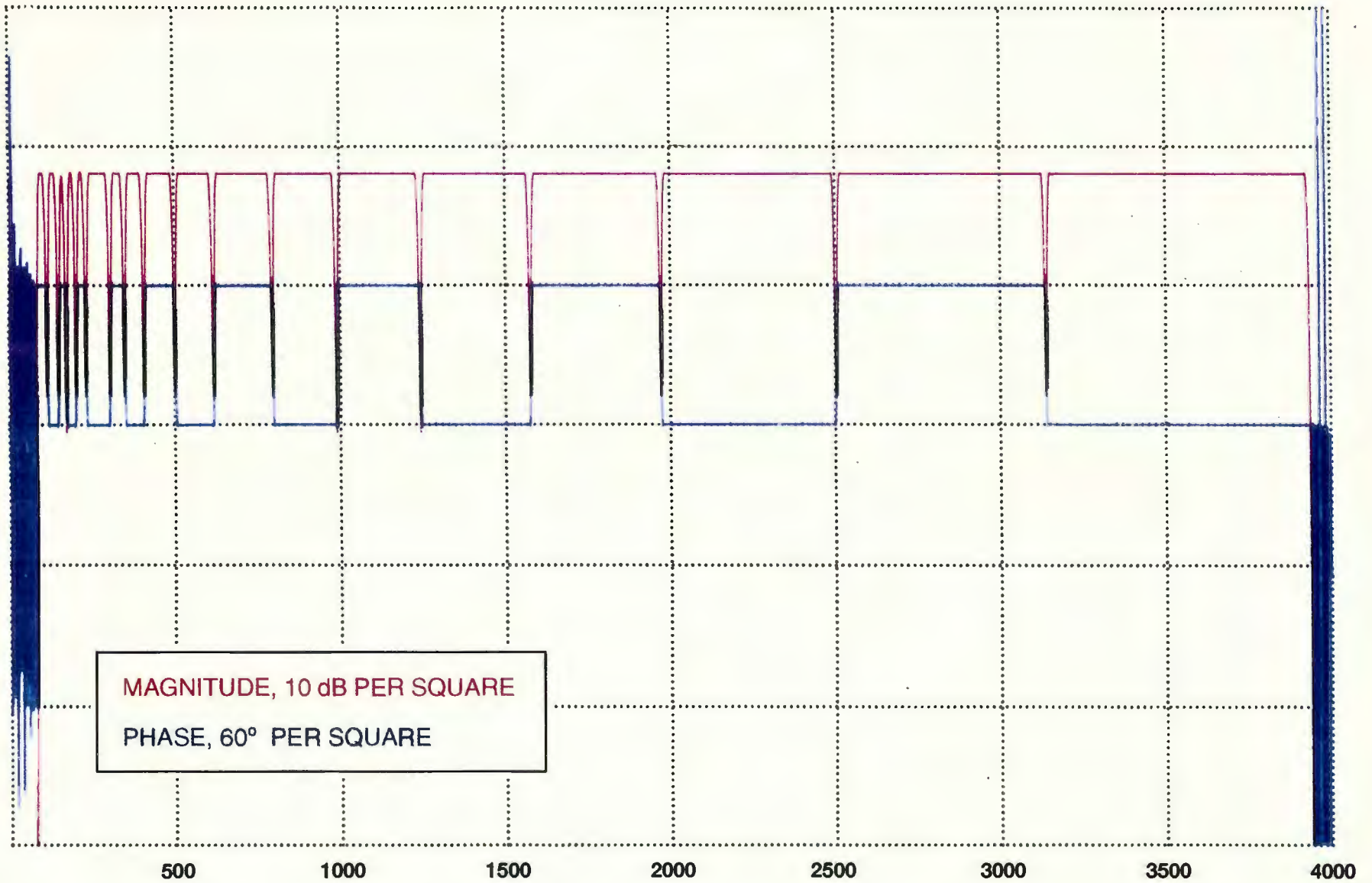

Figure 10. Bank of Digital Comb Filters. Frequency Range: 90 Hz to 4000 Hz.

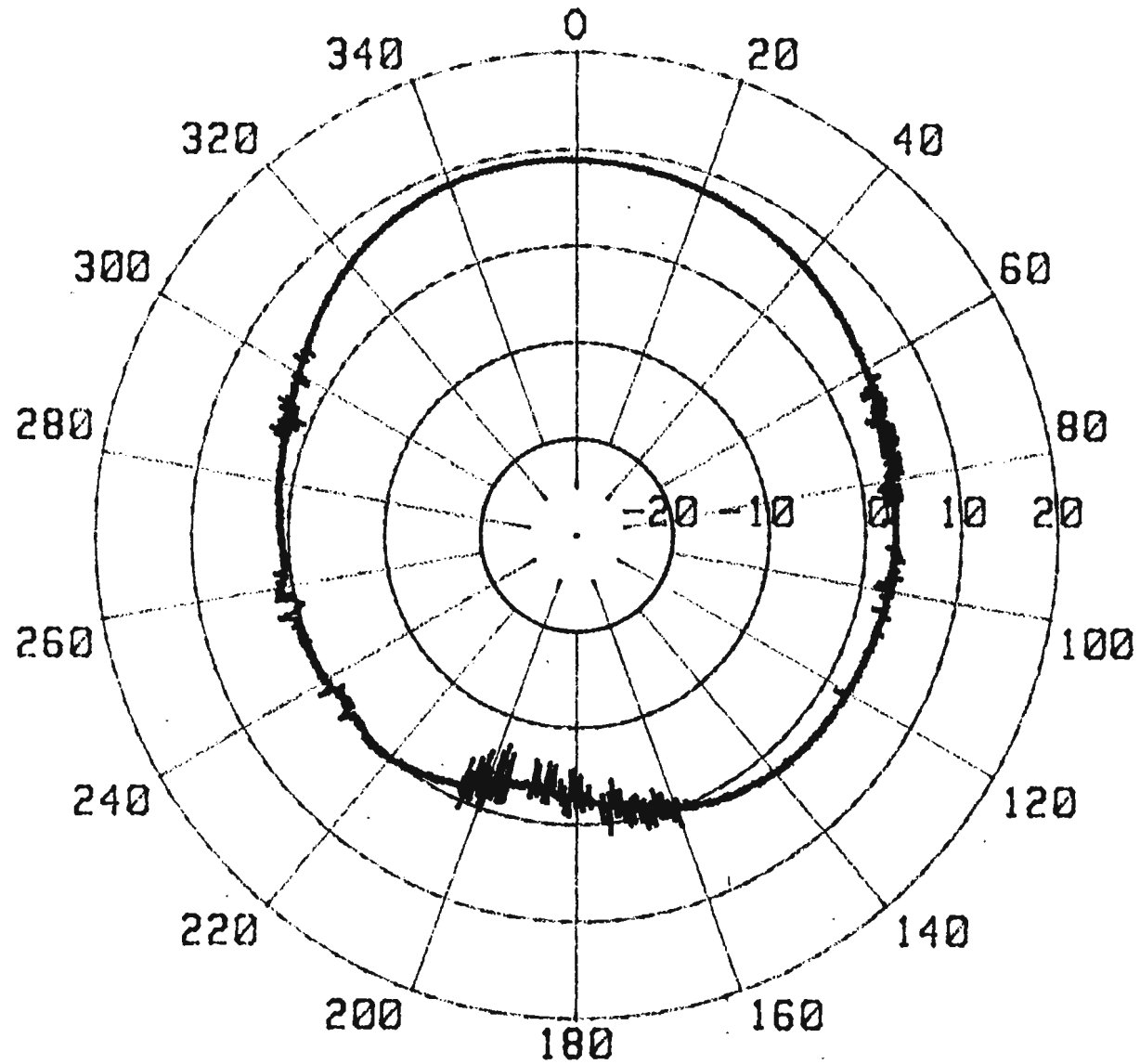

Figure 11. Primary Sensor Pattern at 1000 Hz (Microphone Next to Manikin)

REFERENCES

1. H. B. Miller, "Noise-Reduction System for Underwater Arrays (Semi-Active System), Volume 1," NUWC-NPT Technical Report 10,625, Naval Undersea Warfare Center Detachment, New London, CT, 2 June 1994.



ADDENDUM TO NUWC-NPT TM 951034

"HEARING AID HAVING GREATLY IMPROVED SIGNAL-TO-ROOMNOISE RATIO"

The June 1994 report, NUWC-NPT TR 10,625 entitled "Noise-Reducing System for Underwater Arrays," provides the foundation for what we are trying to achieve in this Hearing Aid project.

Figure 66 from TR 10,625 shows (just barely) the four tonals we are trying to recover from a huge background of noise, as indicated by a **coherence** curve of noise plus signal.

Figure 69 from TR 10,625 shows the successful recovery of the four tonals (plus two artifacts) at the output of an adaptive filter system. The noise is reduced across the band by 10 to 20 dB.

The theory is discussed in Section 6 of TR 10,625 (see especially pp. 40-42).

The Hearing Aid project is more difficult than the ship-noise project because the reference sensor in a room cannot be made as signal-free as is possible in the unbounded ocean.

The approach being taken is to design a reference sensor with a more sophisticated directional pattern than was used for the ship-noise project.

**HULL - NOISE COHERENCE C_N BETWEEN
REFERENCE TWO - POLE Σ H3, H2 (0° , 0°)
AND
PRIMARY H3 (0°)
AT STA 3**

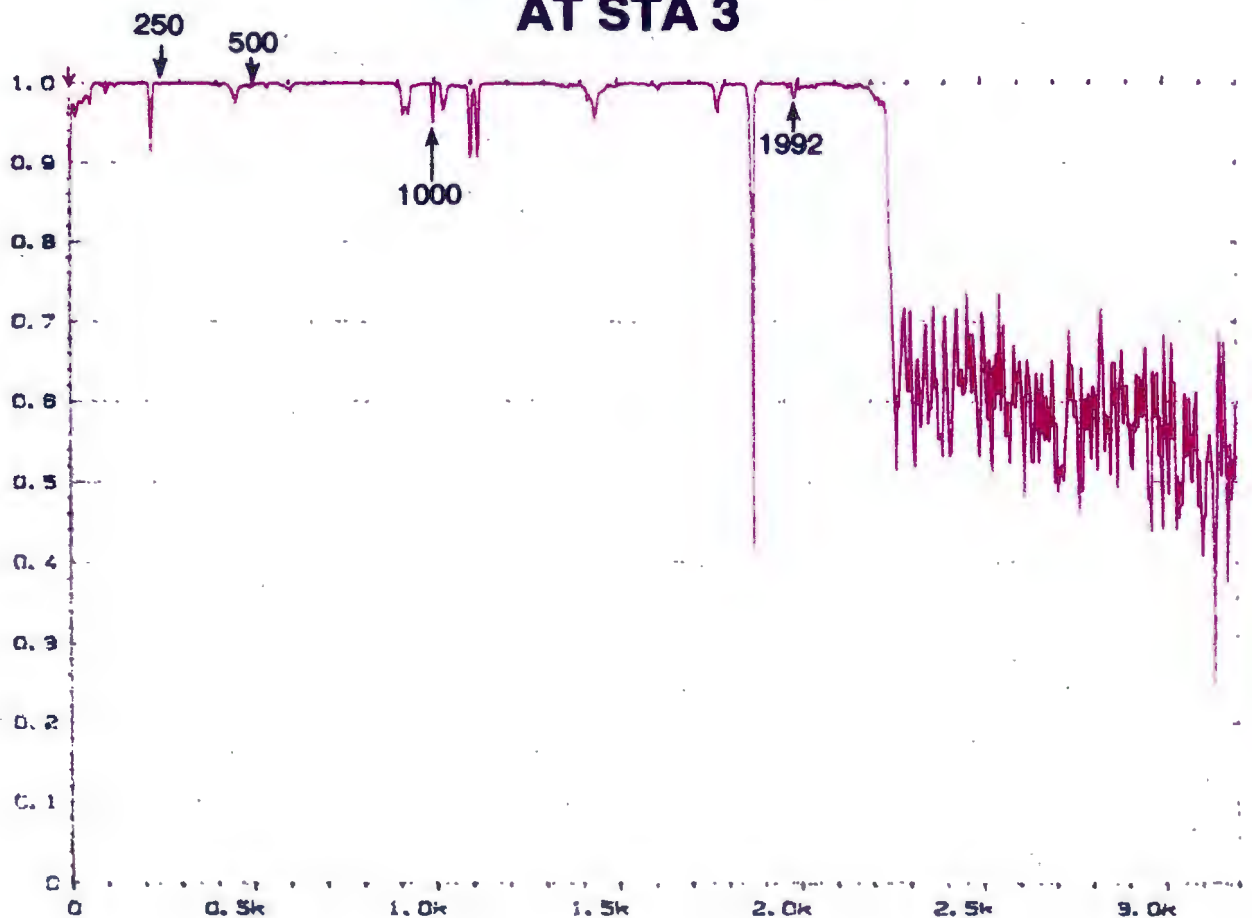

Figure 66

TYPICAL NOISE CANCELLATION OF DOUBLET Σ H3, H2 (0° , 180°)

STA 3

$\theta = 0^\circ$

S/N RATIO = 0 dB

BLUE : INPUT HULL - NOISE PLUS TONALS (SIGNAL)

RED : OUTPUT HULL - NOISE PLUS TONALS OUT OF
ADAPTIVE FILTER

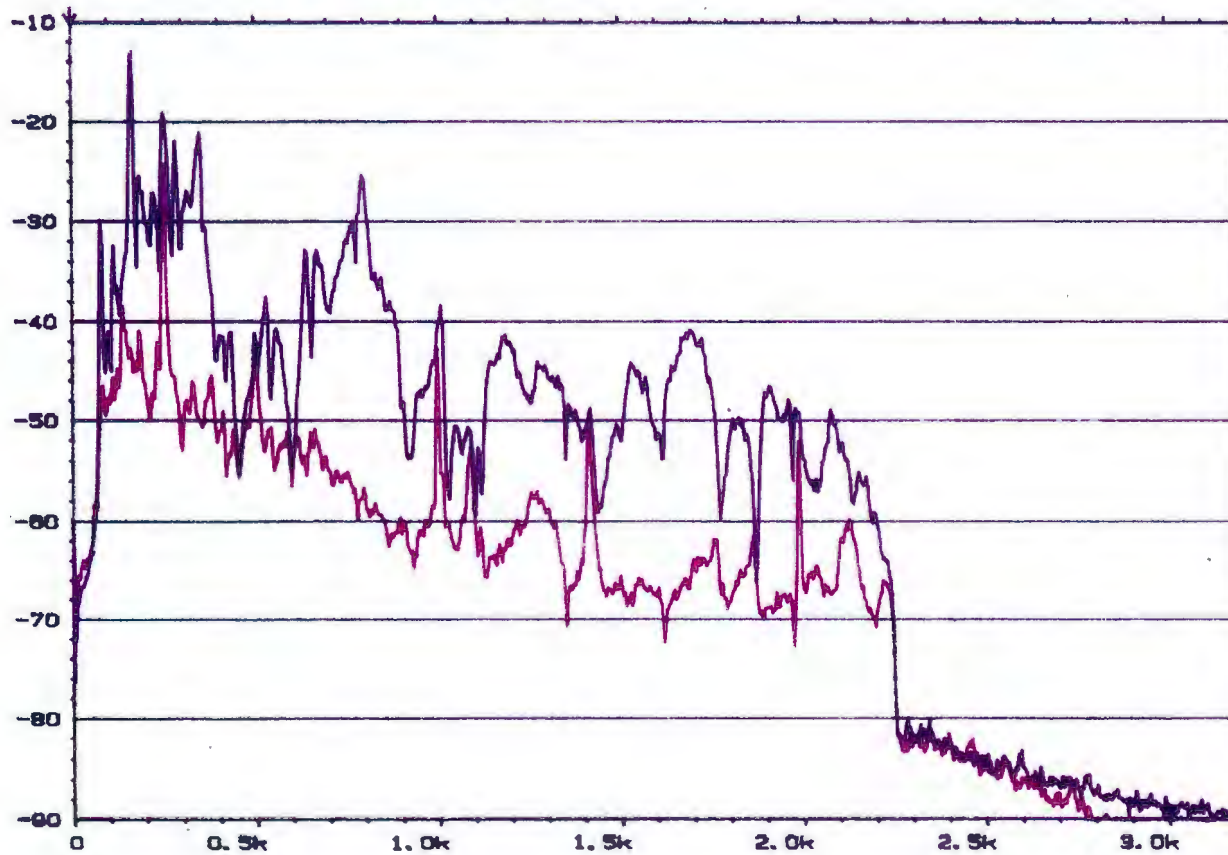

Figure 69

DISTRIBUTION LIST

External

University of Texas, Research Labs (Attn: Dr. C. M. McKinney)

Internal

Codes: 000C (P. Lall)
10 (R. Nadolink)
10A (R. LaPlante)
102 (K. Lima)
21 (R. Martin, F. Manganelli, C. Carter)
2101 (M. Fein)
2123 (N. Owsley, J. Ianniello)
2192 (R. O'Neill)
213 (B. McTaggart, F. Tito)
2131 (R. Janus, G. Kavarnos, J. Lindberg, P. Monahan, J. Powers, H. Miller (5))
2133 (H. Schloemer, R. Christman)
33B (C. Nawrocki)
0251 (A. Mastan)
0261 (NLON Library (2))
0262 (NPT Library)

Total: 31