

# 100-kV, 1-kHz BLUMLEIN PULSER FOR MICROWAVE APPLICATIONS

L.E. Kingsley, R. Pastore, H. Singh, Marc S. Litz†

U.S. Army Research Laboratory

Pulse Power Center  
AMSRL-EP-MC  
Fort Monmouth, NJ 07703-5601

†Weapons Technology Directorate  
AMSRL-WT-NH  
Adelphi, MD 20783

S. Behr, J. Creedon

Vitronics, Inc.  
15 Meridian Rd.  
Eatontown, NJ 07724

## ABSTRACT

This work discusses our ongoing development of a 100-kV, 130-kW modulator for use in high-power microwave research. This modulator is designed to deliver 1 microsecond pulses at a 1-KHz repetition rate into a 70 Ω load. The pulser utilizes an ITT F-316 four-gap thyatron to switch two 5-section E\*-type pulse-forming lines connected in a Blumlein configuration. The pulser is relatively compact, and can be moved from testbed to testbed. We will review our pulser design and present data demonstrating the operation of the pulser, showing output voltage and current waveforms. 1-kHz PRF operation as yet can not be demonstrated due to power supply limitations, although submillisecond recharge times have been observed indicating the pulser is 1-kHz capable.

## INTRODUCTION

This unit was built by the U.S. Army Pulse Power Center (PPC) of Army Research Laboratory (ARL), Fort Monmouth, NJ to meet the need for a research modulator to test new high-power microwave sources under development at Weapons Technology Directorate (WTD), ARL, Adelphi, MD. The modulator was to be designed for use in experimental studies of vircator microwave sources underway at WTD, and for testing of new high-power magnetrons being developed elsewhere. The vircator study has required building a whole new testing facility at the Adelphi site and this facility required a modulator which could produce 1-μsec pulses at 100 kV at 1 kHz, with shot-to-shot reproducibility. A kilohertz data

acquisition rate is essential for the study of the electron dynamics in the vircator, hence the repetition rate and reproducibility requirements of the modulator. Another requirement was that the modulator be relatively compact and be movable from testbed to testbed within the facility. Fabrication of the modulator was completed in December, 1992 and the unit was shipped to Adelphi before it could be fully rated at the PPC. Adjustment and improvements continue at its new location at WTD, Adelphi. The design specifications are summarized below.

## PULSER DESIGN SPECIFICATIONS

Output Voltage = 100 kilovolts  
Output Pulsewidth = 1 microsecond  
Output Impedance = 70 Ohms  
Pulse Repetition Rate = 1000 Hz

## DESIGN OF 100-kV BLUMLEIN MODULATOR

### Pulse Forming Line

A conventional Blumlein has been constructed using two identical PFL's connected as in Fig.1. Each PFL is a 5-section E\*-type line with a characteristic impedance of 35 Ohm. An E\*-type line is a PFL with equal section capacitance and with all the section inductances, including any mutual inductances, provided by appropriately tapping one continuously-wound inductor. An E\*-

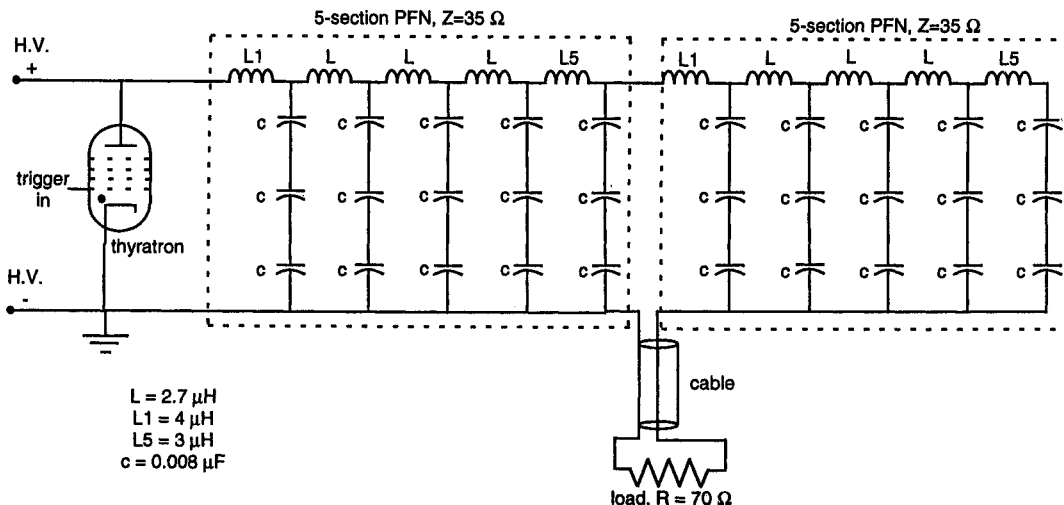

Figure 1. Circuit schematic for Blumlein pulser consisting of two 35-Ω PFL's.

## Report Documentation Page

*Form Approved*  
*OMB No. 0704-0188*

Public reporting burden for the collection of information is estimated to average 1 hour per response, including the time for reviewing instructions, searching existing data sources, gathering and maintaining the data needed, and completing and reviewing the collection of information. Send comments regarding this burden estimate or any other aspect of this collection of information, including suggestions for reducing this burden, to Washington Headquarters Services, Directorate for Information Operations and Reports, 1215 Jefferson Davis Highway, Suite 1204, Arlington VA 22202-4302. Respondents should be aware that notwithstanding any other provision of law, no person shall be subject to a penalty for failing to comply with a collection of information if it does not display a currently valid OMB control number.

1. REPORT DATE <b>JUN 1993</b>	2. REPORT TYPE <b>N/A</b>	3. DATES COVERED <b>-</b>	
4. TITLE AND SUBTITLE <b>PLY 100-kV, 1-kHz Blumlein Pulser For Microwave Applications</b>		5a. CONTRACT NUMBER	
		5b. GRANT NUMBER	
		5c. PROGRAM ELEMENT NUMBER	
6. AUTHOR(S)		5d. PROJECT NUMBER	
		5e. TASK NUMBER	
		5f. WORK UNIT NUMBER	
7. PERFORMING ORGANIZATION NAME(S) AND ADDRESS(ES) <b>U.S. Army Research Laboratory Pulse Power Center AMSRL-EP-MC Fort Monmouth, NJ 07703-5601</b>		8. PERFORMING ORGANIZATION REPORT NUMBER	
9. SPONSORING/MONITORING AGENCY NAME(S) AND ADDRESS(ES)		10. SPONSOR/MONITOR'S ACRONYM(S)	
		11. SPONSOR/MONITOR'S REPORT NUMBER(S)	
12. DISTRIBUTION/AVAILABILITY STATEMENT <b>Approved for public release, distribution unlimited</b>			
13. SUPPLEMENTARY NOTES <b>See also ADM002371. 2013 IEEE Pulsed Power Conference, Digest of Technical Papers 1976-2013, and Abstracts of the 2013 IEEE International Conference on Plasma Science. Held in San Francisco, CA on 16-21 June 2013. U.S. Government or Federal Purpose Rights License.</b>			
14. ABSTRACT <b>This work discusses our ongoing development of a 100-kV, 130- kW modulator for use in high-power microwave research. This modulator is designed to deliver 1 microsecond pulses at a 1-KHz repetition rate into a 70 Q load. The pulser utilizes an ITT F-316 four-gap thyatron to switch two 5-section E*-type pulse-forming lines connected in a Blumlein configuration. The pulser is relatively compact, and can be moved from testbed to testbed. We will review our pulser design and present data demonstrating the operation of the pulser, showing output voltage and current waveforms. 1-kHz PRF operation as yet can not be demonstrated due to power supply limitations, although submillisecond recharge times have been observed indicating the pulser is 1-kHz capable.</b>			
15. SUBJECT TERMS			
16. SECURITY CLASSIFICATION OF:			17. LIMITATION OF ABSTRACT <b>SAR</b>
a. REPORT <b>unclassified</b>	b. ABSTRACT <b>unclassified</b>	c. THIS PAGE <b>unclassified</b>	
			18. NUMBER OF PAGES <b>4</b>
			19a. NAME OF RESPONSIBLE PERSON

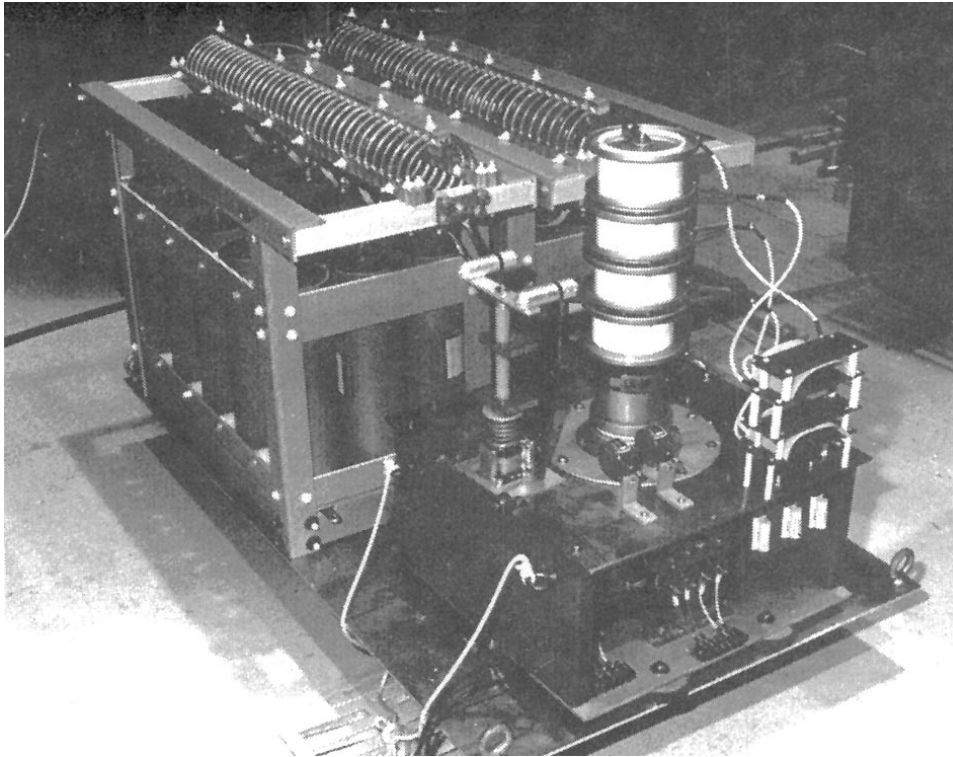

Figure 2. Blumlein pulser assembly out of its oil tank. For scale, the thyatron in the foreground is 18 inches tall.

type line provides the desired amount of mutual inductance between sections by choosing an appropriate geometry for the single inductor. This is very practical PFL to fabricate. A 5-section line was chosen to produce the best pulse in the physical space allowed for the PFL.

In the design of any PFL, the choice of the section parameters, C and L, is primarily determined by the desired characteristic line impedance and pulse width. A PFL design study performed by Bramley and Greenwald [1] gives suggested optimum values for the section parameters that have been determined empirically for lines of various type and number of sections. For a 5-section E\*-type PFL, the value of the section capacitance, C, is given by the relation

$$C = (0.2874) \frac{\tau}{\pi R}$$

where  $\tau$  is the design pulsewidth, R is the line impedance, and 0.2874 is an empirically determined factor. For  $\tau = 1$  microsecond and  $R = 35$  Ohm, the optimum  $C = 2.6$  nanofarads. Of practical concern in achieving this optimum value is the availability of capacitors that are rated to handle the design PFL voltage. For this application, the practical value for C is 2.7 nanofarads and consists physically of three 0.008 microfarad capacitors connected in series. These capacitors were obtained from Condensor Products and have a voltage rating of 50 kV. Three of these capacitors in series, then, have rating of 150 kV. The total network capacitance is 27 nanofarads.

The optimum average section inductance, L, is given by

$$L = (0.2299) \frac{\tau R}{\pi}$$

where the factor 0.2299 is the average value from the Bramley and Greenwald empirical study. For this design, the optimum L is 2.64 microhenries. This value can be realized by a number of combinations of section length, winding pitch, and coil diameter of the continuous single coil. A particular coil geometry must be chosen to provide the correct mutual inductance between sections. Roberts [2] has analyzed the Bramley and Greenwald data and has noted that the mutual inductance between sections of the optimum

PFL is very nearly 15% of L. It is shown that a coil with a diameter to section length ratio of 0.75 will have mutual inductance of 15% between sections. Two identical inductors were fabricated on site using these guidelines, one for each PFL. Each inductor has 36 turns, a pitch of one turn per inch, and a diameter of 4.5 inches. They were constructed by winding 3/8-inch copper tubing around a grooved form, unscrewing the form from the tubing and bracing the resulting coil with polycarbonate spacers. The coils are tapped every 6 1/3 turns (for a section length of six inches) for the center three sections; the end sections have 6 1/3-plus turns to allow for inductance tuning. Experience and circuit modeling indicate that 10-50% extra inductance in the first and last section is desirable. For the center three sections, L is 2.7 microhenries. The diameter to length ratio is 4.5 in/6 in = 0.75. The inductors may be tapped anywhere along their length to alter and tune the pulse shape.

#### Thyatron

Two thyratrons were evaluated for this application, the English Electric Valve CX2593X and the ITT F-316. Both thyratrons were four-gap designs rated for 100-kV operation. Also, although not required for this design, both thyratrons had hollow anodes. After testing, the ITT F-316 was chosen, primarily due to the poor recovery of the EEV CX2593X at higher repetition rates.

#### System

Fig. 2 shows the actual pulser assembly. The thyatron is in the foreground (EEV CX2593X shown) and the PFL's are behind it. The whole assembly fits inside a 3' x 3' x 5' oil-filled steel tank. The tank rides on 10-in. phenolic wheels, providing high-voltage isolation and limited mobility. The pulser is mounted on a hydraulic lift table so it can be raised above the oil for easy access for adjustments and maintenance. This facilitates tuning of the pulse shape to suit user requirements. The pulser assembly is shown raised out of the oil in Fig.3.

#### PULSER OPERATION

The completed modulator was tested at the PPC and testing continues at WTD. At the PPC, a Gentec HV-100 High-Voltage Probe for voltage measurements and a Pearson #1025 Current

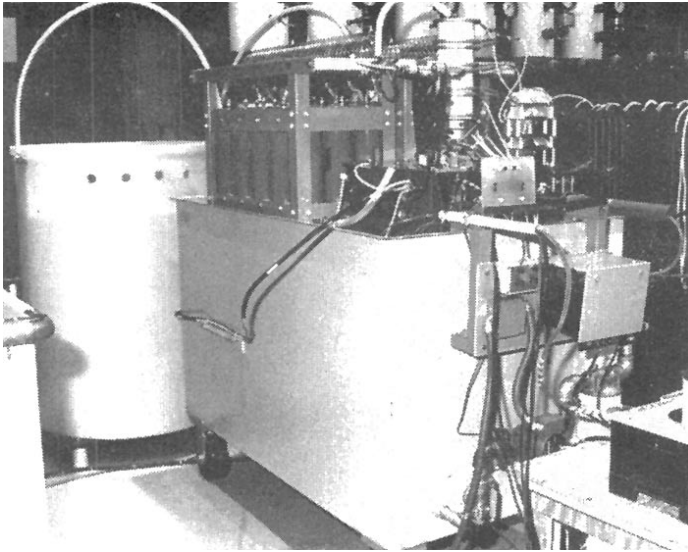

Figure 3. Entire modulator, with the pulser assembly raised above its 3' x 3' x 5' oil tank.

Transformer for current measurements. In addition to these instruments, WTD has fabricated and used their own diagnostics. 100-kV operation, obtained at the PPC, is shown in Fig.4, which shows the voltage and current delivered to a 70-Ω resistive load for a network voltage of 100 kV. The PRF for these waveforms was 5 Hz. Note that for these waveforms, the PFL inductor taps were being adjusted for fastest pulse risetime, and not for flattest pulse. WTD requires a flat pulse and the inductor taps were adjusted accordingly. Fig.5 shows the best load pulse waveshape obtained at the PPC, with the inductor tapplings corresponding to the values listed in Fig.1. In both Figs.4 & 5 the arrow on the timescale indicates the triggering time of the thyatron. Some noise from the thyatron firing is observed on the load diagnostics. The PRF for the pulse shown in Fig. 5 was 400 Hz, the maximum PRF obtained at the PPC before it was necessary to discontinue testing at the PPC and ship the unit to WTD.

The pulser was reassembled at WTD and testing was resumed. WTD is still awaiting installation of an appropriate high-voltage power supply for this modulator, so the testing has concentrated on verifying the suitability of the modulator for their microwave source studies. Pulse reproducibility is a major issue. Fig.6 shows three sequential load current wave forms overlaid. There is little pulse-to-pulse variation or jitter, aside from the diagnostic noise.

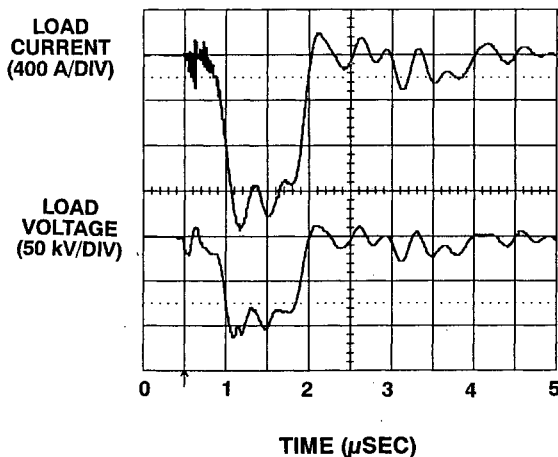

Figure 4. Voltage and current delivered to 70-Ω resistive load for a network bias of 100-kV. PFL inductor taps not optimized for flattest pulse. Arrow on time axis indicates firing of thyatron.

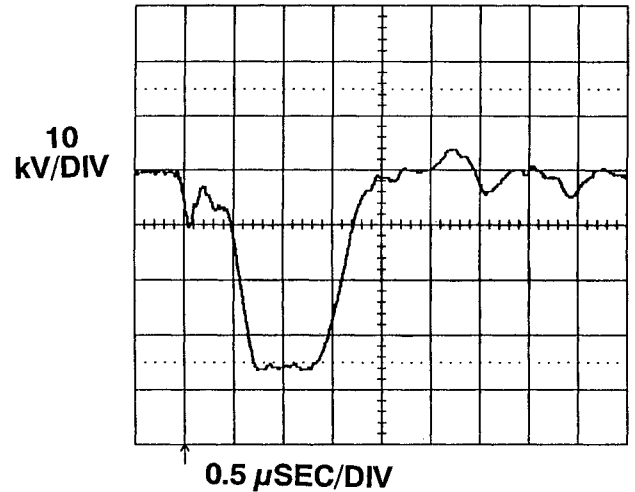

Figure 5. Voltage at resistive load with PFL inductor taps adjusted for flattest pulse.

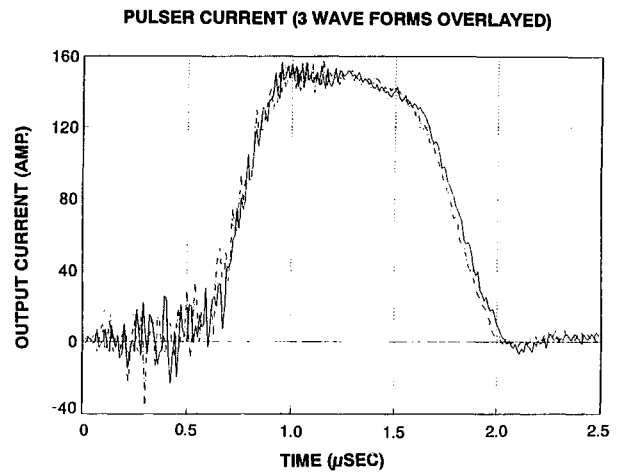

Figure 6. Three current pulses at 70-Ω resistive load overlaid. Note pulse reproducibility.

The pulser was connected to the experimental vircator source via RG218 cable. WTD has installed pulse voltage and current monitors in the vircator assembly, using a capacitive pick-up for voltage and a B-dot sensor for the current. Voltage and current pulses delivered to the vircator are shown in Figs. 7 & 8, respectively. Note the excellent waveshape of the pulse delivered to the vircator. There is ~ 10 nanoseconds of integration inherent to these sensors. Also, there is a DC-offset evident in Fig.7 which must still be corrected in calibration.

It is not possible for WTD to demonstrate 1-kHz operation of the modulator until the requisite 130-kW supply is installed. The modulator is ready when the DC supply is on-line. A 2.71-Henry charging inductor was produced by National Winding Laboratories especially for resonant charging of the modulator for kHz operation. The recharge time using this choke is ~850 microseconds. This choke has been used, in conjunction with a charging diode, at low PRF and the submillisecond recharge time has been verified.

#### CONCLUSION

ARL has designed, fabricated, and demonstrated a 100-kV, thyatron-switched Blumlein modulator. The pulser can produce flat pulses with excellent reproducibility. The unit is installed at WTD, Adelphi where it will be used in their microwave source research.

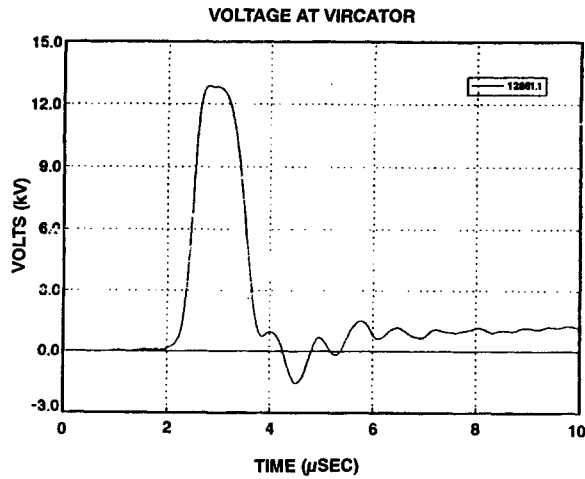

Figure 7. Voltage pulse measured in vircator housing.

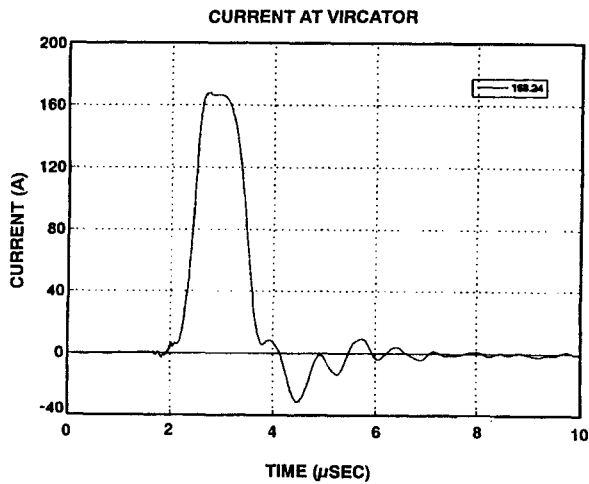

Figure 8. Current pulse at vircator housing.

When the requisite power supply is installed at WTD, 1-kHz operation of the pulser will be obtained. This will provide an especially valuable testing facility for high PRF sources. The kHz PRF also will allow high data acquisition rates for the study of the physics of sources such as the vircator.

#### REFERENCES

- [1] J. Bramley and L. Greenwald, "The Design of Pulse Forming Networks," U.S. Army Service Forces, Camp Evans Signal Lab. Technical Report T-23, (1 Nov. 1943, revised 1 Oct. 1944).
- [2] R. Roberts, Jr., "A PFN Design Method," Air Force Cambridge Research Center Technical Report AFCRC-TR-57-112, ASTIA Document No. AD133626, (June 1957).