

PROGRESS ON THE FORMATION OF A HIGH DENSITY WORKING FLUID FOR SOLID LINER IMPLOSIONS\*

F.M. Lehr, J.H. Degnan, D. Dietz, S.E. Englert, T.J. Englert, T. W. Hussey, G.F. Kiuttu, J.M. Messerschmitt, B.W. Mullins, C.A. Outten, R.E. Peterkin, Jr., N.F. Roderick, P.J. Turchi  
High Energy Plasma Physics Division  
Phillips Laboratory  
Kirtland AFB, NM 87117-6008

J.D. Graham  
Maxwell Laboratories, Inc.  
Albuquerque, NM

Abstract

An experimental system is described which is designed to produce a hot (1-2 eV), dense ( $10^{19}$  cm<sup>-3</sup> neutral plus ion density) hydrogen working fluid via a coaxial gun discharge and inject it into a payload volume. This high sonic velocity fluid will eventually be used as a shockless compression medium for solid liner implosion and hypervelocity projectile experiments. A recent series of experiments to investigate the proper formation and subsequent injection of a working fluid with the desired properties will be discussed. The principal diagnostics used in these experiments include voltage, current, and magnetic field probes, high speed photography, time resolved optical spectroscopy, and piezoresistive pressure probes. MACH2, a 2-1/2 dimensional MHD code, is briefly described. Simulations using MACH2 of a new gun design are discussed.

Introduction

Electromagnetically imploded solid liners have been employed at numerous laboratories as a means of achieving high energy densities for a variety of applications [1-6]. Solid liner implosions are essentially Z-pinch [7] in which the mass of the liner is sufficient to prevent vaporization of the liner during the "run-in" phase of the implosion. Chernyshev [8] recently proposed using solid liners to compress magnetic flux interior to the liner to sufficiently high density that the field pressure can, in turn, implode a central target or liner. The advantages of such a magnetic "working fluid" include decoupling of outer implosion non-uniformities from the central implosion and the possibility of transferring non-spherical liner energy onto a spherical target. The principal drawbacks to such a system are the intrinsic cylindrical symmetry and divergence free nature of the magnetic field.

At the Phillips Laboratory we are exploring the possibility of using hot hydrogen as the working fluid in place of the magnetic field. While this scheme avoids the problems discussed above, it introduces a whole new set of difficulties associated with pressure nonuniformities and shock waves in the fluid. In addition, in order to preserve a spherically symmetric implosion, it is important to minimize the magnetic flux contained within the fluid.

In order to maintain pressure uniformity within the fluid, shocks must be avoided during compression. This requires that the fluid sonic velocity be greater than the inner surface implosion velocity of the outer liner (typically reaching 10 to 20 km/s late in the implosion). Calculations suggest that an initial temperature of 1 eV is sufficient to insure pressure isotropy, while wall heating considerations dictate that the temperature be kept as low as possible. Shockless compression of a working fluid has applications in other areas, such as high pressure equation of state studies and hypervelocity projectile acceleration.

Given the temperature and required final pressure after implosion for a particular geometry, the minimum initial working fluid density can be estimated. Because of various energy loss mechanisms, including radiative losses and phase transitions such as molecular dissociation and atomic ionization, the working fluid pressure will not increase like that of a  $\gamma=5/3$  ideal gas. Rather, it has been determined from two dimensional CALE calculations [9] that these processes may be

accounted for by using an effective  $\gamma$  of 1.2-1.4 [10]. If the desired final pressure after implosion is 10 Mbar, the required initial working fluid pressure is 30-600 bar (for a realistic degree of radial compression and taking  $\gamma = 1.4$ ). For a 1 eV plasma, this pressure translates into a heavy particle number density in the range of  $1 \times 10^{19}$ - $2 \times 10^{20}$  cm<sup>-3</sup>.

The purpose of this research program, then, is to determine how a uniform, 1-2 eV,  $1 \times 10^{19}$ - $2 \times 10^{20}$  atom/cm<sup>3</sup>, magnetic field-free working fluid can be produced and injected into a "payload volume" representing the interliner volume. Recent experimental and computational efforts to that end are discussed in this paper.

Experimental Approach and Diagnostics

The experimental effort has centered around the use of prefilled coaxial plasma guns to heat and compress a (typically) hydrogen plasma and inject it into the payload volume. The details of the gun designs have evolved over time, but all have used an inverse Z-pinch discharge along a cylindrical pyrex insulator for initiation. This is shown schematically in Fig. 1. The initial discharge across the insulator is lifted off of the insulator and driven down the gun by the  $J \times B$  force. This current sheath sweeps the prefill gas ahead of it into the payload volume. The current source for the guns was initially a 44.4  $\mu$ F capacitor bank, storing 35.5 kJ at 40 kV and delivering 0.5 MA to the gun. It has recently been replaced with a 73  $\mu$ F, 125 kJ bank.

An early gun design is shown in Fig. 2. While this gun was successful in producing a working fluid with close to the desired fluid properties, it did not exclude magnetic flux from the payload volume. The results obtained with this gun design were the subject of a recent submission for publication [11] and will not be discussed further in this paper.

The next generation gun, which addresses the magnetic flux exclusion problem, is shown in Fig. 3. An array of 30 conducting axial vanes are placed at the entrance to the payload volume. The use of such vanes to exclude magnetic flux while allowing plasma to flow through is based upon previous experience in our laboratory with their use in plasma flow switches [12]. Since the vanes are conducting and bridge the interelectrode gap, an insulating break was placed in the center conductor just upstream of the vanes, as shown in

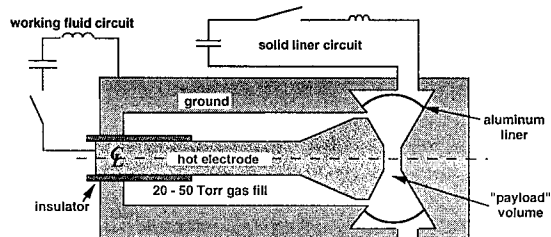

Fig. 1. Schematic of the inverse Z-pinch / coaxial gun working fluid concept. The initial breakdown occurs across the insulator, producing an inverse pinch which heats and partially ionizes the hydrogen. The magnetic force from the discharge then pushes the gas to the right, down the barrel of the gun and into the payload volume. If the a liner were actually used, it would be located as shown.

\*This work is supported by the Air Force Office of Scientific Research

## Report Documentation Page

*Form Approved*  
OMB No. 0704-0188

Public reporting burden for the collection of information is estimated to average 1 hour per response, including the time for reviewing instructions, searching existing data sources, gathering and maintaining the data needed, and completing and reviewing the collection of information. Send comments regarding this burden estimate or any other aspect of this collection of information, including suggestions for reducing this burden, to Washington Headquarters Services, Directorate for Information Operations and Reports, 1215 Jefferson Davis Highway, Suite 1204, Arlington VA 22202-4302. Respondents should be aware that notwithstanding any other provision of law, no person shall be subject to a penalty for failing to comply with a collection of information if it does not display a currently valid OMB control number.

1. REPORT DATE <b>JUN 1993</b>	2. REPORT TYPE <b>N/A</b>	3. DATES COVERED <b>-</b>	
4. TITLE AND SUBTITLE <b>Progress On The Formation Of A High Density Working Fluid For Solid Liner Implosions</b>		5a. CONTRACT NUMBER	
		5b. GRANT NUMBER	
		5c. PROGRAM ELEMENT NUMBER	
6. AUTHOR(S)		5d. PROJECT NUMBER	
		5e. TASK NUMBER	
		5f. WORK UNIT NUMBER	
7. PERFORMING ORGANIZATION NAME(S) AND ADDRESS(ES) <b>High Energy Plasma Physics Division Phillips Laboratory Kirtland AFB, NM 87117-6008</b>		8. PERFORMING ORGANIZATION REPORT NUMBER	
9. SPONSORING/MONITORING AGENCY NAME(S) AND ADDRESS(ES)		10. SPONSOR/MONITOR'S ACRONYM(S)	
		11. SPONSOR/MONITOR'S REPORT NUMBER(S)	
12. DISTRIBUTION/AVAILABILITY STATEMENT <b>Approved for public release, distribution unlimited</b>			
13. SUPPLEMENTARY NOTES <b>See also ADM002371. 2013 IEEE Pulsed Power Conference, Digest of Technical Papers 1976-2013, and Abstracts of the 2013 IEEE International Conference on Plasma Science. Held in San Francisco, CA on 16-21 June 2013. U.S. Government or Federal Purpose Rights License</b>			
14. ABSTRACT <b>An experimental system is described which is designed to produce a hot (1-2 eV), dense (10<sup>19</sup> cm<sup>-3</sup> neutral plus ion density) hydrogen working fluid via a coaxial gun discharge and inject it into a payload volume. This high sonic velocity fluid will eventually be used as a shockless compression medium for solid liner implosion and hypervelocity projectile experiments. A recent series of experiments to investigate the proper formation and subsequent injection of a working fluid with the desired properties will be discussed. The principal diagnostics used in these experiments include voltage, current, and magnetic field probes, high speed photography, time resolved optical spectroscopy, and piezoresistive pressure probes. MACH2, a 2-1/2 dimensional MHD code, is briefly described. Simulations using MACH2 of a new gun design are discussed.</b>			
15. SUBJECT TERMS			
16. SECURITY CLASSIFICATION OF:			17. LIMITATION OF ABSTRACT <b>SAR</b>
a. REPORT <b>unclassified</b>	b. ABSTRACT <b>unclassified</b>	c. THIS PAGE <b>unclassified</b>	
			18. NUMBER OF PAGES <b>4</b>
			19a. NAME OF RESPONSIBLE PERSON

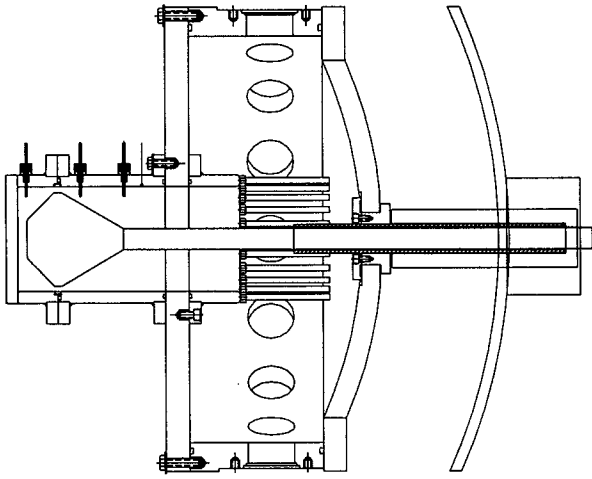

Fig. 2. An early gun design which used an open annular nozzle geometry to inject the working fluid.

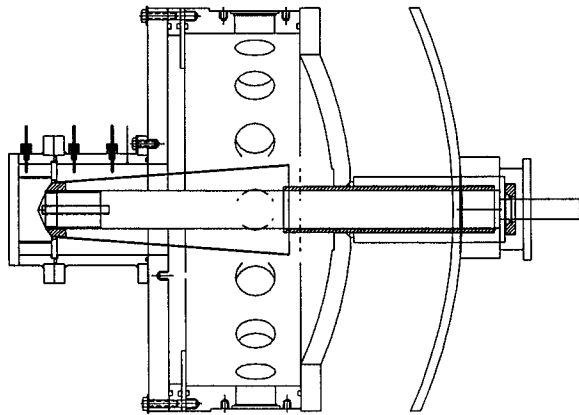

Fig. 3. A later gun design incorporating axial conducting vanes to exclude magnetic flux from the payload volume.

Fig. 3. This insulating break eliminates current flow, and therefore magnetic flux, ahead of the plasma sheath.

The principal diagnostics used in the experiments include time resolved optical spectroscopy, magnetic field and voltage probes, high speed photography using gated microchannel plate (MCP) and rotating mirror fast framing cameras, and, recently, piezoresistive and piezoelectric pressure probes.

The spectral characteristics of the plasma are measured using an optical multichannel analyzer (OMA) having a variable time gate capability. The optical signals are transmitted with four silica cored optical fibers arrayed to give chordal views across the payload volume, views parallel to the gun axis, or a combination of the two. Wavelengths of less than 400 nm are severely attenuated in the optical fibers used, which effectively limits the analysis to the Balmer series, specifically  $H_{\alpha}$ ,  $H_{\beta}$ , and  $H_{\gamma}$ .

#### Experimental Results

Typical experimental parameters for the gun shown in Fig. 3 are a hydrogen prefill of 20 torr and a capacitor bank stored energy of 33 kJ, resulting in a peak discharge current of 0.5 MA. Magnetic field probes are placed at the three axial locations in Fig. 3. The third probe location is in the payload volume, i.e., downstream of the magnetic flux excluding vanes. At this probe location, there is no discernable magnetic field amplitude.

The most notable feature of measured spectra (obtained from chordal views across the payload volume) is the absence of the  $H_{\alpha}$  line until relatively late in the plasma evolution. When compared to the continuum, there is strong evidence that this absence is due to resonance absorption. Even at relatively late times (e.g., 45  $\mu$ s into the discharge) it is impossible to determine the electron temperature,  $T_e$ , from the ratio of the  $H_{\alpha}$  to  $H_{\beta}$  intensity, as the observed intensities are nearly equal.

For views parallel to the axis of symmetry (but off axis), the intensity ratios of  $H_{\alpha}$  and  $H_{\beta}$  allow calculation of the electron temperature. In all cases, commercially available peak fitting software is used to determine the line intensity ratios. The electron temperature and density as a function of time into the discharge are shown in Fig. 4. The electron density,  $n_e$ , is calculated from the width of the  $H_{\beta}$  line. Since there appear to be absorption processes at play, a certain amount of skepticism must be assigned to the results presented in Fig. 4. The net result of the observed absorption will be to give calculated values of both electron density and temperature which are too high. Thus the values shown in Fig. 4 probably represent an upper bound on these quantities.

Efforts to quantify the absorption are in progress. The absorption may, in fact, prove to be a useful diagnostic. For  $n_e \geq 10^{18}$  cm<sup>-3</sup> absorption due to inverse Bremsstrahlung at wavelengths of 632.8 nm (i.e., a HeNe laser) and greater becomes sufficient to provide a viable technique for unambiguously measuring the electron density and temperature. The preferential absorption of the  $H_{\alpha}$  line evident in the observed spectra further suggests that there is a significant fraction of the hydrogen in the n=2 state. This may provide an avenue for further diagnosis of the properties of the fluid.

Direct pressure measurements using piezoresistive and piezoelectric probes are in their infancy and have not yet yielded reliable results. Factors leading to uncertainty in such measurements include the contribution of ablation pressure and the photo response of the probe crystal.

#### Numerical Simulations and Future Designs

Numerical simulations using the code MACH2 are employed to help understand the physics of the working fluid experiment, interpret experimental data, and analyze the performance of new experimental designs. MACH2, which has been described in detail elsewhere [13], solves the time dependent, single fluid, multitemperature, nonideal radiation magnetohydrodynamic (MHD) equations on a two dimensional mesh composed of arbitrarily shaped quadrilateral cells. It is an arbitrary Lagrangian Eulerian (ALE) code which calculates the time evolution of all three components of the velocity and magnetic vector fields.

MACH2 has been used extensively to analyze the next generation gun design, which is shown in Fig. 5. This gun will be installed on the 125 kJ capacitor bank

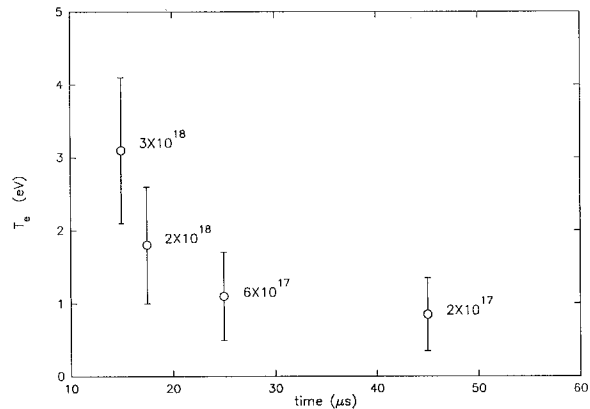

Fig. 4. Electron temperature,  $T_e$ , calculated from spectroscopic data, as a function of time into the gun discharge. The parameter is the calculated electron density at each time. These data are for a 0.5 MA peak discharge in a 20 torr  $H_2$  prefill.

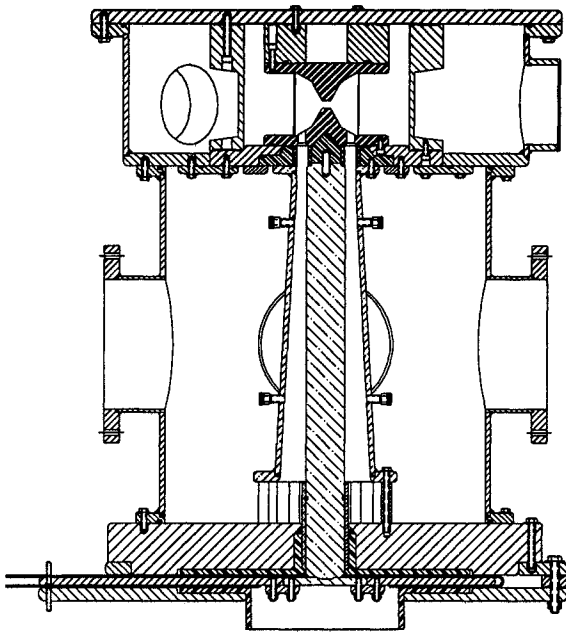

Fig. 5. Next generation gun design which will be fielded on the SHIVA Star 9.3 MJ capacitor bank for injection of working fluid during actual liner implosions.

for testing, and will eventually be used for the initial round of solid liner implosion experiments with working fluid injection on the Phillips Laboratory's 9.3 MJ SHIVA Star capacitor bank [5]. During these experiments, the working fluid formation gun will be driven by an existing capacitor bank capable of storing 800 kJ, although only a fraction of this energy should be required for working fluid formation and injection.

The electron temperatures and heavy particle densities predicted by MACH2 at several locations in the payload volume are shown in Figs. 6 and 7. This simulation was for a hydrogen prefill of 5 Torr and an 87 kJ capacitor bank energy level. This rather low prefill pressure was chosen to "match" the gun to the initial driver circuit (i.e., to have the current sheath reach the payload volume at the time corresponding to peak current). As can be seen from Figs. 6 and 7, the electron temperature is, in general, higher than desired

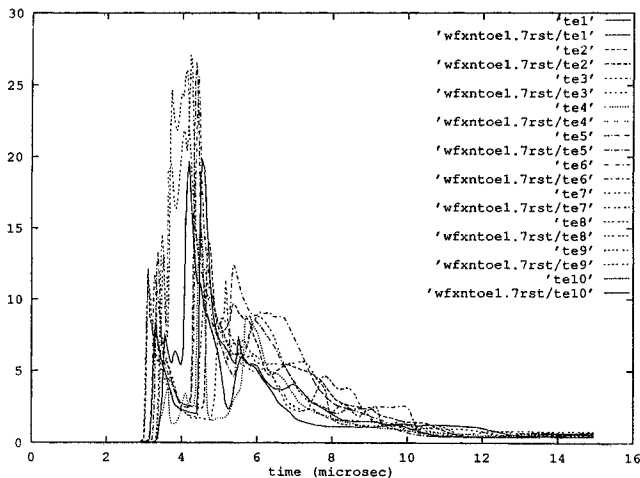

Fig. 6. Electron temperatures (in eV) calculated by the MACH2 MHD code for various locations in the payload volume of the gun shown in Fig. 5. The prefill was 5 torr H<sub>2</sub> for these simulations.

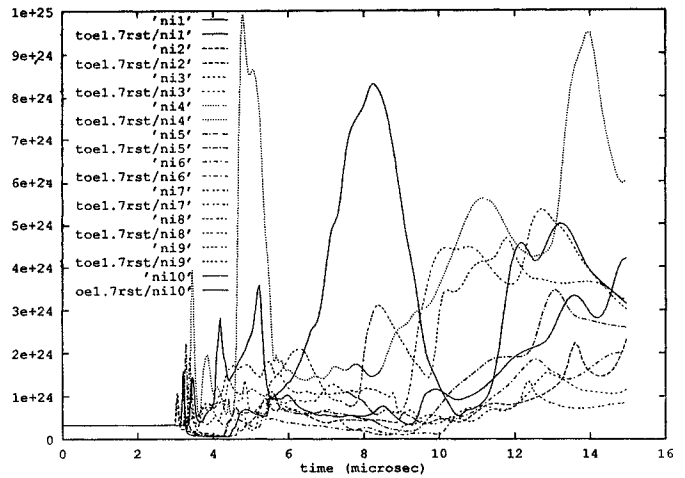

Fig. 7. Heavy particle (neutral plus ion) densities (in m<sup>-3</sup>) calculated by the MACH2 MHD code for various locations in the payload volume of the gun shown in Fig. 5. The prefill was 5 torr H<sub>2</sub> for these simulations.

while the heavy particle density is lower. In this simulation the presence of the vanes, which would require a fully 3 dimensional code to model explicitly, is accounted for by a boundary condition which allows plasma to flow through while blocking magnetic flux at the entrance to the payload volume.

By using higher prefill pressures than in the simulation discussed above, it is likely that the working fluid properties will converge toward the desired values. Initial experiments using this gun design will operate at as high a prefill pressure as possible. Simulations are underway to elucidate the working fluid properties at higher initial pressures and to determine the current risetime required to "match" the gun. Tuning of the experiment discharge risetime to match the sheath rundown time will be accomplished with a section of variable inductance transmission line. The practical upper limit on prefill pressure is determined by acceptable initiation of the current sheath, with the sheath tending to constrict into fewer luminous "spokes" with increasing pressure. Modelling of the initiation problem again requires a fully 3 dimensional code, which additionally would be required to contain a sophisticated gas and/or insulator surface breakdown model.

### Conclusions

The formation and subsequent injection into a "payload" volume of a hot hydrogen working fluid has been studied experimentally and numerically. Hydrogen filled coaxial plasma guns driven by capacitor bank discharges have thus far produced a fluid somewhat hotter and less dense than desired. Some uncertainty in temperature and density values derived from spectroscopic data is introduced by the observed absorption effects. Indeed, absorption due to inverse Bremsstrahlung is presently being explored as a diagnostic technique. Axial conducting vanes at the entrance to the payload volume appear to be successful in blocking magnetic field while allowing the plasma to flow through.

Simulations using the code MACH2 indicate that, at low hydrogen prefill pressures, the latest gun design will produce a fluid which is still hotter and less dense than desired. However, operation at higher prefill pressures should result in fluid properties which are closer to those desired. Numerical studies are presently underway to study the effect of higher prefill pressures on the gun performance.

### Acknowledgments

The support of this work by the Air Force Office of Scientific Research is greatly appreciated. The authors would like to give special thanks to D. Dunlap, D. Gale, K. Golby, W. Kaiser, R. Sedillo, M. Sena, and A. Trujillo of Maxwell Laboratories, Inc., and G. Baca of the Phillips Laboratory for their contributions to the experiment.

### References

- [1] P.J. Turchi, A.L. Cooper, R.D. Ford, D.J. Jenkins, and R.L. Burton, Megagauss Physics and Technology, P.J. Turchi, ed., New York: Plenum Press, 1985, pp. 375.
- [2] S.G. Alikhanov, V.P. Bakhtin, and D.A. Toporkov, Ultrahigh Magnetic Fields-Physics, Techniques, Applications, V.M. Titov and G.A. Shvetsov, eds., Moscow: Nauka, 1984, pp. 213.
- [3] A.G. Eskov, M.I. Kitayev, and R.Kh. Kurtmullayev, Ultrahigh Magnetic Fields-Physics, Techniques, Applications, V.M. Titov and G.A. Shvetsov, eds., Moscow: Nauka, 1984, pp. 204.
- [4] A.A. Petrukhin, N.P. Bidlyo, S.F. Garanin, V.M. Danov, V.V. Zmushko, A.I. Kuzyaev, V.N. Mokhov, E.S. Pavlovskii, V.A. Prokopov, M.S. Protosov, V.K. Chernyshev, V.A. Shvetsov, and V.B. Yakubov, Ultrahigh Magnetic Fields-Physics, Techniques, Applications, V.M. Titov and G.A. Shvetsov, eds., Moscow: Nauka, 1984, pp. 406.
- [5] J.H. Degnan, M.L. Alme, W.L. Baker, J.S. Buff, C.B. Boyer, C.J. Clouse, S.K. Coffey, D.W. Conley, D. Dietz, J.D. Graham, S.L. Gonzalez, K.E. Hackett, D.J. Hall, J.L. Holmes, E.A. Lopez, W.F. McCullough, D.W. Price, R.E. Reinovsky, N.F. Roderick, P.J. Turchi, and J.M. Welby, Megagauss Technology and Pulsed Power Applications, C.M. Fowler, R.S. Caird, and D.J. Erickson, eds., New York: Plenum Press, 1987, pp. 699-706.
- [6] J.H. Degnan, W.L. Baker, J.D. Beason, C.J. Clouse, D. Dietz, D.J. Hall, J.L. Holmes, D.W. Price, and C.R. Sovinec, Megagauss Fields and Pulsed Power Systems, V.M. Titov and G.A. Shvetsov, eds., New York: Nova Science Publishers, 1990, pp. 623-630.
- [7] N.A. Krall and A.W. Trivelpiece, Principles of Plasma Physics, New York: McGraw Hill, 1973.
- [8] V.K. Chernyshev, V.N. Mokhov, M.S. Protosov, V.B. Yakubov, A.A. Petrukhin, A.I. Kuzyaev, E.S. Pavlovskii, A.M. Buyko, B.E. Grinevitch, V.I. Mamyshev, V.V. Vakhrushev, V.A. Shvetsov, and V.A. Demidov, Digest of Technical Papers: Eighth IEEE International Pulsed Power Conference, R. White and K. Prestwich, eds., New York: Institute of Electrical and Electronics Engineers, 1991, pp. 438-456.
- [9] T.W. Hussey, N.F. Roderick, and D.A. Kloc, *J. Appl. Phys.* 51, pp. 1452, 1980.
- [10] T.W. Hussey, R.E. Peterkin, D. Dietz, J.H. Degnan, J.D. Beason, N.F. Roderick, and P.J. Turchi, IEEE Conference Record-Abstracts, 1992 IEEE International Conference on Plasma Science, New York: Institute of Electrical and Electronics Engineers, 1991.
- [11] F.M. Lehr, A. Alaniz, J.D. Beason, L.C. Carswell, J.H. Degnan, J.F. Crawford, S.E. Englert, T.J. Englert, J.M. Gahl, J.H. Holmes, T.W. Hussey, G.F. Kiuttu, B.W. Mullins, R.E. Peterkin, Jr., N.F. Roderick, P.J. Turchi, "Formation of plasma working fluids for compression by liner implosions," submitted to *J. Appl. Phys.*
- [12] J.H. Degnan, W.L. Baker, K.E. Hackett, D.J. Hall, J.L. Holmes, J.B. Kriebel, D.W. Price, R.E. Reinovsky, J.D. Graham, E.A. Lopez, M.L. Alme, G. Bird, C.N. Boyer, S.K. Coffey, D. Conte, J.F. Davis, III, S.W. Seiler, and P.J. Turchi, *IEEE Trans. Plasma Sci.*, PS-15, pp. 760, 1987.
- [13] National Technical Information Service Document No. ADA 192285 (Mission Research Corporation Report AMRC-R-874 by M.H. Frese, 1987). Copies may be obtained from the National Technical Information Service, Springfield, VA 22161.