

Approved by

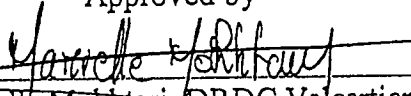

Marielle Mokhtari, DRDC Valcartier
Defence Scientist in Modeling and Simulation

François Bernier, DRDC Valcartier
Defence Scientist in Modeling and Simulation

CLASSIFICATION / DESIGNATION
WARNING TERM

Abstract

This report provides a state-of-the-art review on the role of Modeling and Simulation (M&S) in the context of the Capability Engineering Process (CEP) as defined so far by the CapDEM TD initiative. It briefly positions the preliminary guidelines proposed by the CEP within the current DND/CF acquisition process, and describes how this new process, once finalized, will efficiently implement Simulation Based Acquisition (SBA) concepts through a Collaborative Engineering Environment (CEE). The report also presents some M&S fundamentals and its use within the military acquisition process, before it describes how M&S could be used to support the main CEP activities. Some M&S tools products which could be considered for the CEP are also presented before the report concludes with suggested areas of opportunity to help refine M&S role within the CEP.

Résumé

Ce rapport fournit une revue de l'état de l'art sur le rôle de la modélisation et simulation (M&S) dans le contexte du processus d'ingénierie des capacités (PIC) tel que défini jusqu'à présent dans le cadre de l'initiative DIGCap. Le rapport présente brièvement les lignes directrices préliminaires suggérées par le PIC à l'endroit du processus d'acquisition en vigueur au MDN/FC, et décrit comment celui-ci devrait permettre d'appuyer efficacement, une fois son élaboration complétée, les concepts d'acquisition basées sur la simulation (ABS) dans un environnement collaboratif d'ingénierie des capacités (IC). Les concepts fondamentaux de la M&S sont ensuite présentés ainsi que son application dans le cadre du processus d'acquisition de capacités dans le domaine militaire. Subséquemment, le rapport décrit comment la M&S peut être mise à profit lors des principales étapes du PIC et présente à l'égard de ce dernier certains outils de modélisation et de simulation pouvant être envisagés. Le rapport conclut en identifiant des zones d'opportunité susceptibles d'aider l'initiative DIGCap dans la poursuite de ses travaux, à mieux définir le rôle de la M&S à l'égard du PIC.

This page intentionally left blank.

Executive summary

The Collaborative Capability Definition Engineering and Management (CapDEM) Technology Demonstrator Program initiative is investigating Capability Engineering (CE) in order to improve an acquisition process (15+ years) that does not meet the rapid evolution of business requirements and technology, that does not support the new capability-based approach promoted by DND/CF and that is not adapted for the increasing complexity of Systems of Systems (SoS). To that end, a new Capability Engineering Process (CEP) is required. The CEP will be based on:

- Best practices and standards issued from traditional Systems Engineering (SysEng);
- Best practices in SoS;
- Best practices in Simulation Based Acquisition (SBA); and
- Tools and technologies facilitating data/information exchange and collaboration among engineers, scientists, users and managers at multiple distributed geographic-locations for the purpose of defining, develop and evaluate a capability.

State-of-the-art reviews with respect to SysEng, Modeling & Simulation (M&S), Tools and Technologies, and, Systems of Systems Engineering (SoSEng) will provide input to the definition of the CEP.

The current report concerns the role of M&S in the context of the preliminary guidelines defined so far for the CEP. The report also provides examples of M&S tools, which could eventually be considered to support the CEP.

M&S and the Capability Engineering Process (CEP)

The CEP aims at defining, through the use of SysEng processes, how military capabilities should be defined, engineered and managed in order to help DND/CF deliver new capability better, faster and cheaper. As the CEP is still at an early definition stage, this report is based on the set of preliminary guidelines released by CapDEM for the new process.

With the help of a Collaborative Engineering Environment (CEE) and a robust suite of M&S tools, one of CEP objectives is to promote SBA and facilitate information sharing and collaboration among the participants involved in the acquisition process. It is believed that the use of M&S within a spiral development approach will allow to better define military capability alternatives, better evaluate their respective performance, maximize reutilization across the acquisition process, and minimize risks. In this context, the most significant benefits coming from the use of M&S (e.g. costs reduction) should be observed after the CEP activities have been completed, during implementation and the subsequent acquisition phases.

Requirement Analysis, Analysis of Alternatives, Design and Engineering, and Test and Evaluation (T&E) are some of the key functional domain areas supported by M&S throughout the acquisition process. Also, in order to be used effectively, M&S must rely on some supporting processes such as Simulation Support Plan (SSP), Verification, Validation and Accreditation (VV&A), and Configuration Management (CM).

M&S AND CEP

The set of preliminary guidelines defined for the CEP is composed of the following main activities:

1) Establish the current situation

Within this activity, M&S can be especially helpful in the following areas:

- To model the organizational structure, the activities performed by each element, the information flow among participating organizations, and the functional decomposition and allocation;
- To model and simulate information flow and processes, platform/facility physical models, system physical models, user interface physical models, and operational personnel and manning;
- To measure inherent capabilities (Measures Of Performance - MOP, Measures Of Effectiveness - MOE).

2) Develop a Capability Vision

Within this specific activity, M&S can be particularly helpful in the following areas:

- To assess technology;
- To develop and evaluate doctrine and tactics;
- To develop and evaluate force structure;
- To perform trade-offs and cost analysis.

3) Develop an Architecture

Within this specific activity, M&S can be especially helpful in the following areas:

- To create, evaluate and compare alternative architectures from existing ones or from new ones;
- To develop the organizational, physical and technical models;
- To measure inherent capabilities (cost and effectiveness).

4) Establish the Transformation Roadmap

Within this specific activity, M&S can be especially helpful in the following areas:

- To help define the organizational evolution plan;
- To help define the capability (functional) evolution plan;
- To help define the force training & transition plan;
- To help define the investment plan.

The Way Ahead

As the CEP definition is still at an early stage, the role of M&S will be refined as the new process' description matures. Also, since M&S will be globally managed within DND/CF throughout the entire acquisition life cycle, there are potentially great benefits to align future CapDEM work, with respect to M&S, on DND/CF global strategy and try to create a greater synergy with similar M&S initiatives currently going on within the organization.

Wellwood, M., Drouin, C. 2004. CapDEM TD – Modeling and Simulation (Role), State of the Art Report, W7701-3-2621 Defence Research and Development Valcartier.

Sommaire

L'initiative d'ingénierie collaborative et de gestion des capacités (DIGCap) investigue la possibilité de faire appel à l'ingénierie des capacités (IngCap) pour améliorer un processus d'acquisition (15ans +) qui ne rencontre plus l'évolution rapide des besoins d'affaires et de la technologie, qui ne supporte pas la nouvelle approche orientée-capacités mise d'avant par le Ministère de la défense nationale (MDN) et les forces canadiennes (FC), et finalement, qui n'est pas adapté à la complexité croissante des systèmes de systèmes (SdS). À cette fin, un nouveau processus d'ingénierie des capacités (PIC) est requis. Le futur PIC sera basé sur :

- Les meilleures pratiques et normes émanant de l'ingénierie de systèmes traditionnelle (IngSys);
- Les meilleures pratiques en matière d'ingénierie de SdS;
- Les meilleures pratiques en matière d'acquisition basée sur la simulation (ABS); et
- Les outils et technologies facilitant les échanges d'information ainsi que la collaboration entre les différents ingénieurs, scientifiques, utilisateurs et gestionnaires répartis géographiquement, dans le but de définir, développer et évaluer les capacités.

Les intrants nécessaires à la définition du PIC seront fournis par les résultats des revues de l'état de l'art portant sur l'IngSys, la modélisation et simulation (M&S), les outils et la technologie d'ingénierie collaborative, ainsi que les SdS.

Le présent rapport concerne le rôle de la M&S dans le contexte des lignes directrices préliminaires du PIC définies dans le cadre de DIGCap. Par ailleurs, le rapport présente certains outils de modélisation et de simulation envisageables pour le PIC.

Processus d'ingénierie des capacités (PIC)

Le PIC vise à établir, à l'aide de l'ingénierie de systèmes, comment les capacités militaires devraient être définies, conçues et gérées pour permettre au MDN/FC de livrer ses capacités plus efficacement et rapidement, et à moindres coûts. Comme le PIC en est encore à l'étape de définition, ce rapport s'inspire notamment des lignes directrices préliminaires définies pour ce nouveau processus.

Grâce à un environnement collaboratif d'ingénierie des capacités ('CEE'), le PIC aspire particulièrement à promouvoir l'acquisition basée sur la simulation et à faciliter l'échange d'information et la collaboration entre les différents intervenants impliqués dans le processus d'acquisition. Il convient de croire que l'utilisation de la M&S dans une approche de développement en spirale permettra de mieux définir les alternatives de capacité militaires, de mieux évaluer les performances respectives, de maximiser la réutilisation tout au long du processus d'acquisition et de minimiser les risques. Dans ce contexte, il est anticipé que les bénéfices inhérents à la M&S (par exemple, la réduction des coûts) seront principalement observés après les activités du PIC lors de l'étape de mise en œuvre et des phases d'acquisition subséquentes.

Dans le cadre du processus d'acquisition, les domaines d'application fonctionnels supportés par la M&S incluent notamment l'analyse des besoins, l'analyse d'alternatives, la conception et l'ingénierie technologique ainsi que la réalisation des essais et l'évaluation des résultats associés. Par ailleurs, un usage efficace de la M&S nécessite la mise en place de divers processus, dont :

- un plan de support à la simulation ('SSP');
- des procédures de validation, vérification et certification ('VV&A');
- un plan de gestion de la configuration ('CM').

M&S et PIC

Bien que les détails du PIC ne soient pas encore finalisés, les lignes directrices préliminaires établies à son endroit ont permis d'ébaucher les principales activités du processus de la façon suivante :

1) Établissement de la situation courante

Lors de cette étape, la M&S permet notamment de:

- Modéliser la structure organisationnelle, ses processus et ses fonctions ainsi que les échanges d'information entre ses entités;
- Modéliser et simuler les processus opérationnels et les échanges d'information, les systèmes et plateformes physiques ainsi que les interfaces utilisateurs;
- Mesurer les capacités inhérentes (Mesures de performance ('MOP'), Mesures d'efficacité ('MOE')).

2) Développer une vision à l'égard de la capacité à combler

Lors de cette étape, la M&S permet notamment de:

- Évaluer les technologies;
- Développer et évaluer les doctrines et tactiques;
- Développer et évaluer la composition des forces;
- Effectuer l'analyse de compromis et de coûts.

3) Développer l'architecture intégrée

Lors de cette étape, la M&S permet notamment de:

- Développer, évaluer et comparer les alternatives de solutions à l'égard de la nouvelle architecture intégrée;
- Développer les modèles organisationnels, fonctionnels et physiques de l'architecture intégrée retenue;
- Mesurer les capacités inhérentes de l'architecture intégrée retenue (coûts et efficacité).

4) Définir le plan de transformation

Lors de cette étape, la M&S permet notamment de supporter la définition et l'évolution du:

- Plan de transformation organisationnel;

- Plan de transformation fonctionnel;
- Plan de formation et de transition des effectifs;
- Plan d'investissement.

Compte tenu que la définition du PIC en est encore à un stade préliminaire, le rôle de la M&S dans ce nouveau processus est appelé à se préciser. Par ailleurs, on convient qu'il serait bénéfique d'ajuster les futurs travaux de DIGCap à l'endroit de la M&S sur ceux du MDN/FC pour s'assurer que l'ensemble des actifs en M&S est géré dans une perspective globale. La création d'une plus grande synergie entre DIGCap et les autres initiatives en M&S au sein de l'organisation apparaît aussi comme une opportunité intéressante à explorer.

Wellwood, M., Drouin, C. 2004. CapDEM TD – Modeling and Simulation (Role), State of the Art Report, W7701-3-2621 Defence Research and Development Valcartier.

Table of contents

Abstract.....	i
Executive summary.....	iii
Sommaire.....	vi
Table of contents.....	ix
List of figures.....	xi
1. Introduction.....	1
1.1 Document Objective.....	1
1.2 Background.....	1
1.3 Assumptions.....	2
1.4 Report structure.....	2
2. Capability Engineering Process (CEP).....	3
2.1 Preliminary Definition and Objective.....	3
3. Modeling and Simulation in Acquisition.....	9
3.1 Simulation Based Acquisition (SBA).....	9
3.2 Benefits from early involvement of M&S in the acquisition life cycle.....	13
3.3 M&S Fundamentals.....	14
3.3.1 Definitions.....	14
3.3.2 Simulations Classes.....	14
3.3.3 Hierarchy of Models and Simulations.....	16
3.3.4 Relationship of Models and Simulations.....	21
3.3.5 M&S functional domain areas.....	22
3.3.6 M&S Policy/Guidance.....	25
3.3.7 M&S Related Processes.....	26
3.4 Tools.....	29
3.4.1 Modeling tools.....	29
3.4.2 Simulation tools.....	36

4.	M&S AND CEP.....	41
4.1	Establish the Current Situation	41
4.1.1	Focus.....	41
4.1.2	Activities.....	42
4.1.3	Role of M&S.....	43
4.2	Develop a Capability Vision.....	59
4.2.1	Focus.....	59
4.2.2	Activities.....	59
4.2.3	Role of M&S.....	60
4.3	Develop an Architecture	65
4.3.1	Focus.....	65
4.3.2	Activities.....	65
4.3.3	Role of M&S.....	66
4.4	Establish the Transformation Roadmap.....	71
4.4.1	Focus.....	71
4.4.2	Activities.....	71
4.4.3	Role of M&S.....	72
4.5	M&S Tools in CEP	73
5.	Conclusion and Recommendations.....	74
6.	References.....	76
	Annexes	80
	List of symbols/abbreviations/acronyms/initialisms.....	113

List of figures

Figure 1-1: Current DND/CF Acquisition Process delivery timeframe.....	1
Figure 2-1: CEP within DND/CF Acquisition Process.....	3
Figure 2-2: CEE [6]	4
Figure 2-3: Collaboration through the DPD [3].....	5
Figure 2-4: Sharing of a common CEE throughout all capability-based activities.....	6
Figure 2-5: Capability Engineering Spiral Development Concept [5].....	7
Figure 2-6: Evolution of Models and Simulation Throughout the Acquisition Stages [5]	8
Figure 3-1: Justification for Investment in M&S for Major Acquisition Projects	13
Figure 3-2: Hierarchy of Models and Simulations [8].....	17
Figure 3-3: Linkages between the DPD and the M&S Hierarchy [3].....	19
Figure 3-4: Relationship of Models and Simulations [8].....	21
Figure 3-5: Gartner Magic Quadrant For BPA, 2004 [56].....	31
Figure 3-6: Re-engineering Process Implementation (Casewise) [46]	32
Figure 3-7: Enterprise Architecture Framework Implementation (Casewise) [47]	33
Figure 3-8: C4ISR Modeling Framework Implementation (Popkin) [48].....	33
Figure 3-9: Central Repository Promoting Object Sharing (Casewise) [49]	34
Figure 3-10: Simulation and Analysis Tools (Casewise) [50].....	35
Figure 3-11: OneSAF Product Line Architecture [52]	37
Figure 3-12: To-Be Collaborative Environment [53]	38
Figure 3-13: Top Level view of SBA Systems Architecture [53]	39
Figure 3-14: Collaborative Environment Reference Systems Architecture [53].....	40
Figure 4-1: Example of Organizational Structure Model [18].....	44
Figure 4-2: Example of an Operational Organizational Model [19].....	44

Figure 4-3: Example of Activities Performed by Each Element [20].....	45
Figure 4-4: IDEF 0 Model showing information flow [21].....	47
Figure 4-5: Information Flow Detailed Data Entry [22].....	48
Figure 4-6: Task Network Model Simulation [23].....	49
Figure 4-7: Resource Allocation using WinCrew™ [24].....	50
Figure 4-8: Function Decomposition Relational Database [25].....	52
Figure 4-9: Function Allocation Example [26].....	53
Figure 4-10: Physical Model of a Target Drone (Falconet™) [27].....	54
Figure 4-11: Example of a System Physical Model [28].....	55
Figure 4-12: Example of User Interface Physical Model [29].....	56
Figure 4-13: Example of Personnel in a Constructive Simulation (MicroSaint™) [30].....	57
Figure 4-14: Results of a Constructive Simulation Showing Operator Workload [31].....	58
Figure 4-15: Example of Technology Assessment in SE [32].....	61
Figure 4-16: Tactical Scenario for Doctrine & Tactics Assessment (STAGE™) [33].....	62
Figure 4-17: Example Conceptual Force Structure [34].....	64
Figure 4-18: Example of Modeling Tool with Embedded Costing Data [35].....	69

List of tables

Table 1: Applicability of M&S Through the Acquisition Phases [5].....	10
Table 2: Classes of Simulations [9].....	14
Table 3: Models and Simulations Hierarchy Descriptions [8] [10].....	17
Table 4: Attributes and Uses of Models and Simulations Within The Hierarchy [8].....	20
Table 5: M&S Key Functional Domain Areas.....	22
Table 6: M&S Supporting Processes.....	26

Table 7: M&S Tool Links.....	80
Table 8: Modeling Tool Categories and Products	82
Table 9: Simulation Tools.....	94
Table 10: Mapping of M&S Tools on the CEP Activities.....	109

This page intentionally left blank.

1. Introduction

1.1 Document Objective

As part of the Collaborative Capability Definition, Engineering and Management Technology Demonstration Project (CapDEM TDP), the purpose of this document is to present a state-of-the-art report with respect to the Modeling and Simulation (M&S) role in the context of the Capability Engineering Process (CEP). M&S tools products are also discussed in the report.

1.2 Background

CapDEM TDP is a DND/CF initiative aiming at defining, through the support of System Engineering (SysEng) processes, how military capabilities should be defined, engineered and managed within their respective life cycles (i.e. from 'cradle to grave') [16]. In doing so, the DND/CF goal is to deliver new capability, better, faster and cheaper. As illustrated in Figure 1-1, the current DND/CF acquisition process requires on average more than fifteen (15) years to deliver the Final Operational Capability (FOC) for major acquisition initiatives [1] (as opposed to ten (10) years to deliver the Initial Operational Capability (ICO)).

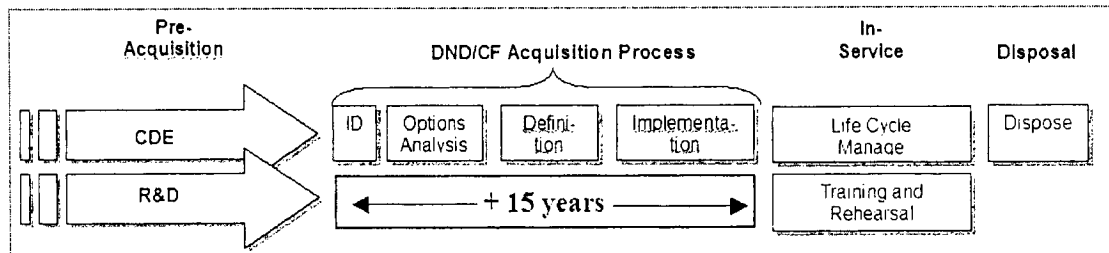

Figure 1-1: Current DND/CF Acquisition Process delivery timeframe

The Advisory Committee on Administrative Efficiency [1] has proposed some changes in order to shorten the Acquisition cycle by about thirty percent (30%), in order to deliver an IOC within a 6.5 years timeframe and reduce the overall delivery life cycle to 10-12 years. It is believed that the new capability-based acquisition process will play a major role in achieving this objective.

In order to adequately support capability-based acquisition, a CEP is being defined by the CapDEM TDP. With an efficient use of M&S tools and processes, CEP should provide a core process to support DND/CF in delivering new capabilities in less time with reduced cost and risk.

The new acquisition process will bring many changes in the way people, processes and machines collaborate in order to create, transform and exchange information throughout the acquisition life cycle. Some of these challenges are:

- Capability-based approach;

- Exploding complexity (people, processes and systems);
- Broad range of missions;
- New/Uncertain threats;
- Coalition/Joint perspective;
- System of Systems (SoS) perspective (requires the development of a high degree of interoperability within existing and new systems);
- Distributed collaborative development environment;
- Joint development and test environment;
- Efficient and secure sharing of products, models, simulations and other related information among distributed participants.

From the work done so far in defining the CEP, a preliminary set of guidelines has been released. The present report was produced in accordance with these guidelines [36].

1.3 Assumptions

The CEP gets involved once an operational capability deficiency has been identified and prioritized.

The capability deficiency context and boundary along with its requirements have been defined to an acceptable level of detail during the pre-acquisition phase that precedes the CEP activities initiation.

1.4 Report structure

The report is structured as follows:

- Section 2 presents the definition of the CEP as expressed by the preliminary guidelines.
- Section 3 introduces the Simulation Based Acquisition (SBA) concepts and objectives. This section also presents some M&S fundamentals along with important elements that must be considered to allow an efficient use of M&S. Some M&S tools to consider for the CEP are finally introduced.
- Section 4 presents the role of M&S in each of the CEP activities and provides some examples of M&S tools for each of them.
- Section 5 presents the report conclusions and suggests some recommendations to further define the role of M&S in CEP. A way ahead is also provided with respect to M&S tools.

2. Capability Engineering Process (CEP)

2.1 Preliminary Definition and Objective

The CEP is defined by a set of ordered activities using collaborative, systematic, disciplined and quantifiable approaches involving people, technologies, and processes to produce a desired capability. CEP activities would be carried out from the start of the IDentification (ID) phase up to early activities in the Implementation phase as illustrated by Figure 2-1.

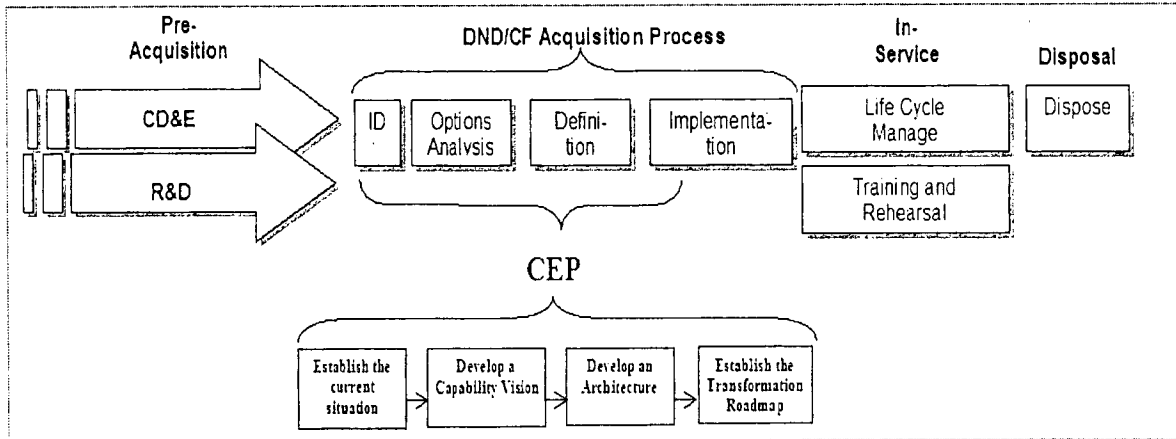

Figure 2-1: CEP within DND/CF Acquisition Process

CEP promotes SBA concepts, which exploit M&S across all acquisition functions and program phases, in order to support enterprise-wide electronic interactions and information sharing through the means of Distributed Product Descriptions (DPDs) supported by a Collaborative Engineering Environment (CEE). As mentioned by Hollenbach [2], *“it allows early and continuing collaborative exploration of the largest possible trade space across the life cycle to all participants and provides the necessary leverage to develop and certify highly interoperable system of systems solutions”*.

As illustrated in Figure 2-2 and Figure 2-3, DPDs are stored in a central repository accessible from the CEE to all participants involved in the various acquisition phases. Although a DPD is composed of multiple data dimensions, such as requirements, design specifications, costs, performance, manufacturing, Test and Evaluation (T&E) scenarios and logistics, it appears to all participants as a logical unified product representation [3]. Import/Export tools and Data Interchange Formats (DIFs) are provided by the CEE to allow information exchanges between the central repository and the users.

In a similar fashion as the one described by Eirich and Coolahan [3], the CEE would store the representation of DND/CF military combat system designs as well as representations of threats systems, operating terrain and environmental conditions, and

alternative scenarios to be simulated. The CEE would also promote the sharing of a distributed M&S Resource Repository (MSRR) to allow “an integrated use of M&S tools across the individual environments from the initial phases of concept development through their exploitation throughout the life cycle of any military capability” [16].

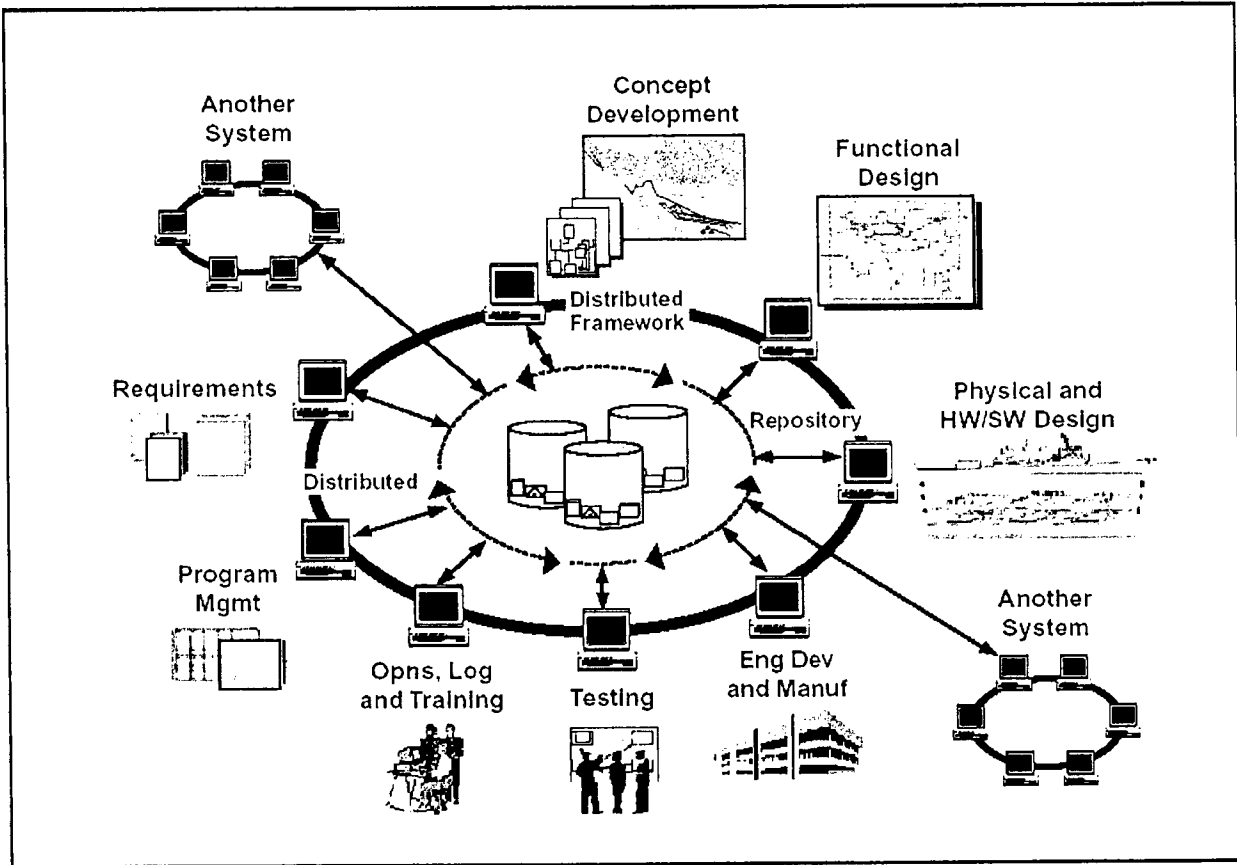

Figure 2-2: CEE [6]

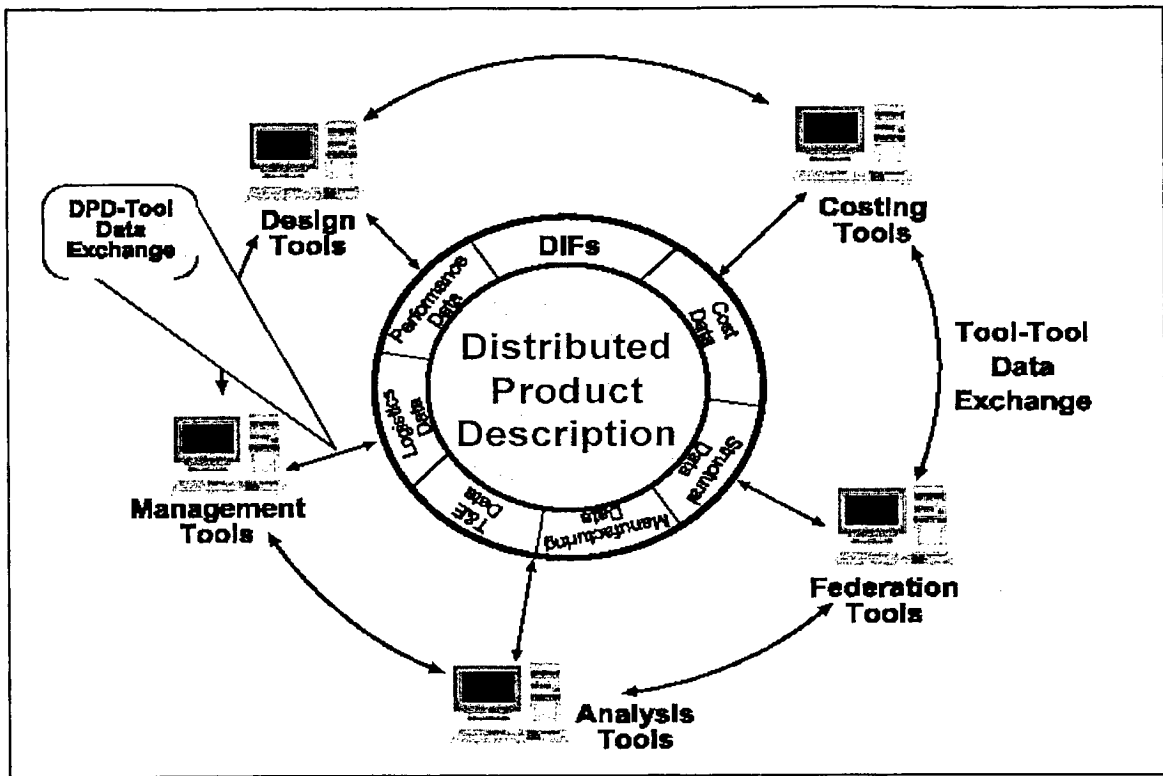

Figure 2-3: Collaboration through the DPD [3]

Eirich and Coolahan [3] also mentioned that “A DPD must maintain coordinated system design (structural) and behaviour (performance) views, must be able to incrementally reflect changed performance parameters in response to design changes, and must address the performance impacts on coordinated combat operations due to changes in any one of the combat system platform design (including the effects of combat damage or component failures)”.

As illustrated in Figure 2-4, the CEE infrastructure would support CEP within the acquisition phase as well as other capability-based activities where M&S tools and processes are involved (e.g. capability-based planning, CD&E, R&D and Maintenance and Support) [16].

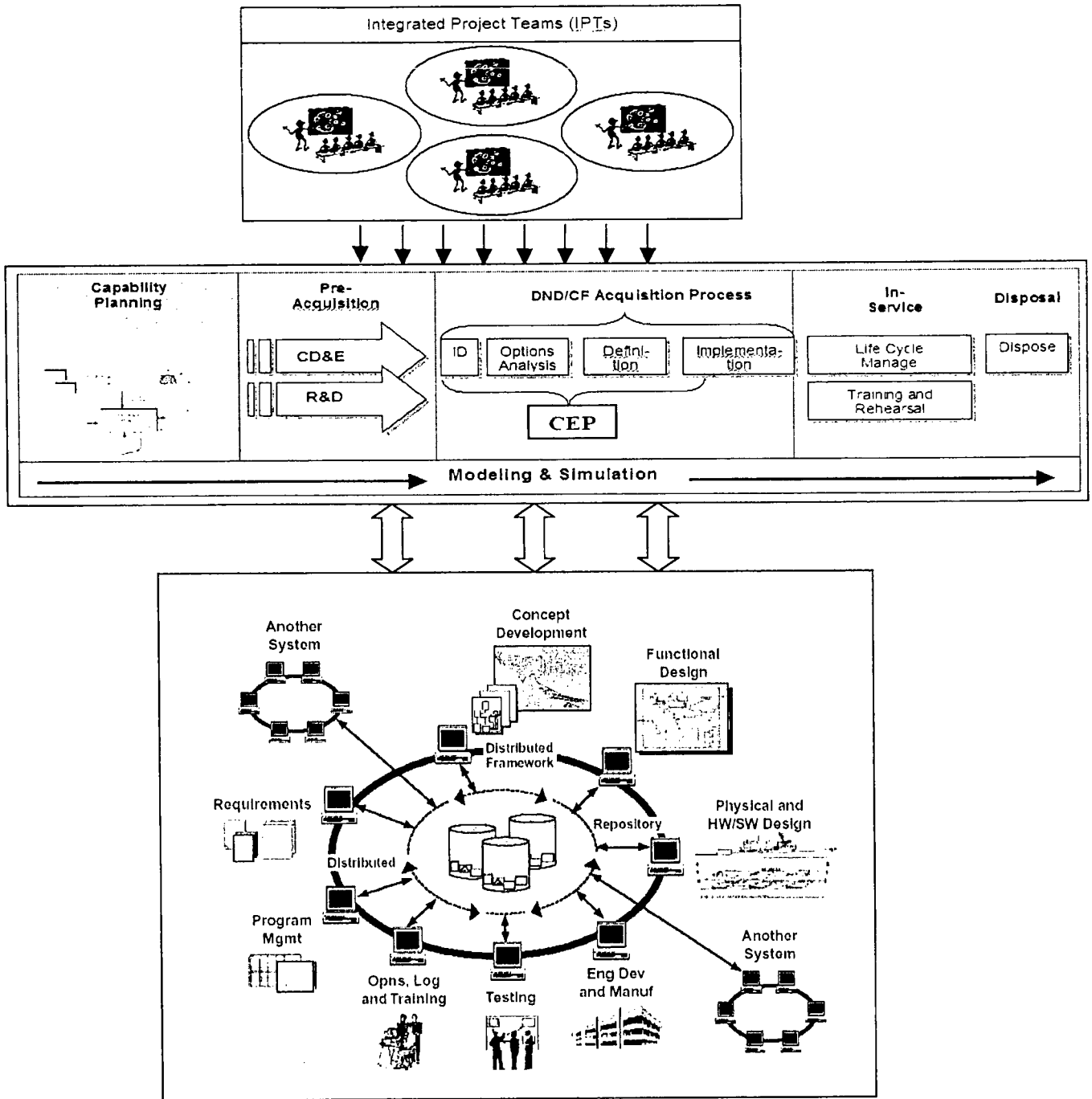

Figure 2-4: Sharing of a common CEE throughout all capability-based activities.

The CEP promotes a spiral development approach throughout the acquisition process. This allows architecture, design, construction, verification, implementation and trade-off studies to be performed at each phase of the process through “virtual system life cycles”. As presented in Figure 2-5, the inner wheel is spun quickly within each phase in order to obtain a continuous increase in the level of details and fidelity of the DPD being developed to address the Capability Deficiency. For each cycle, each activity is addressed at a different level of detail to mitigate risk and ensure achievability of the whole solution [4]. Therefore, the transition from an executing phase to the next one happens when the level of risk is within the desired boundaries (cost, time and performance).

The development of an evolving DPD becomes possible through M&S¹ which provide the necessary tools and processes to virtually assess the effort to develop, deploy and support a new capability as it matures across each phase of the acquisition process. This development approach replaces the traditional « design, build, test, fix procedure » by a « design, simulate, fix, build procedure » which greatly contributes to reduced risk and cost [5].

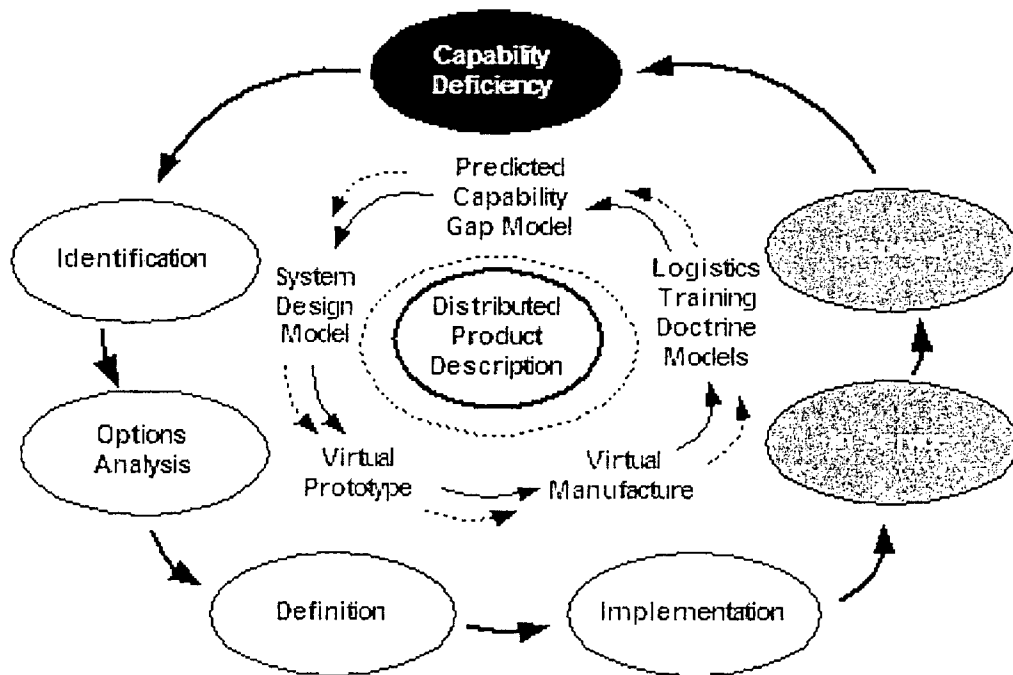

Figure 2-5: Capability Engineering Spiral Development Concept [5]²

As a full capability is often delivered incrementally during the acquisition process, spiral development would also be effective to allow on-going introduction of updates

¹ Among others, models and simulators are used with other tools within a Synthetic Environment (SE). All of these tools contribute to feed the central repository.

² The drawing was adapted to reflect DND/CF acquisition phases.

and enhancements between the phased deliveries. Again, this approach can significantly reduce inherent risks and optimize the overall capability being deployed.

Figure 2-6, extracted from [5], show how low fidelity models and simulations created in the early phases of acquisition, along with the DPD stored in the shared knowledge repository, would naturally evolve³ in a consistent way throughout the process (“SE” stands for Synthetic Environment, which in the present case may refers to the CEE). As the CEP will be involved early, it will play a particular role in establishing the degree of fidelity of the models and simulations to develop.

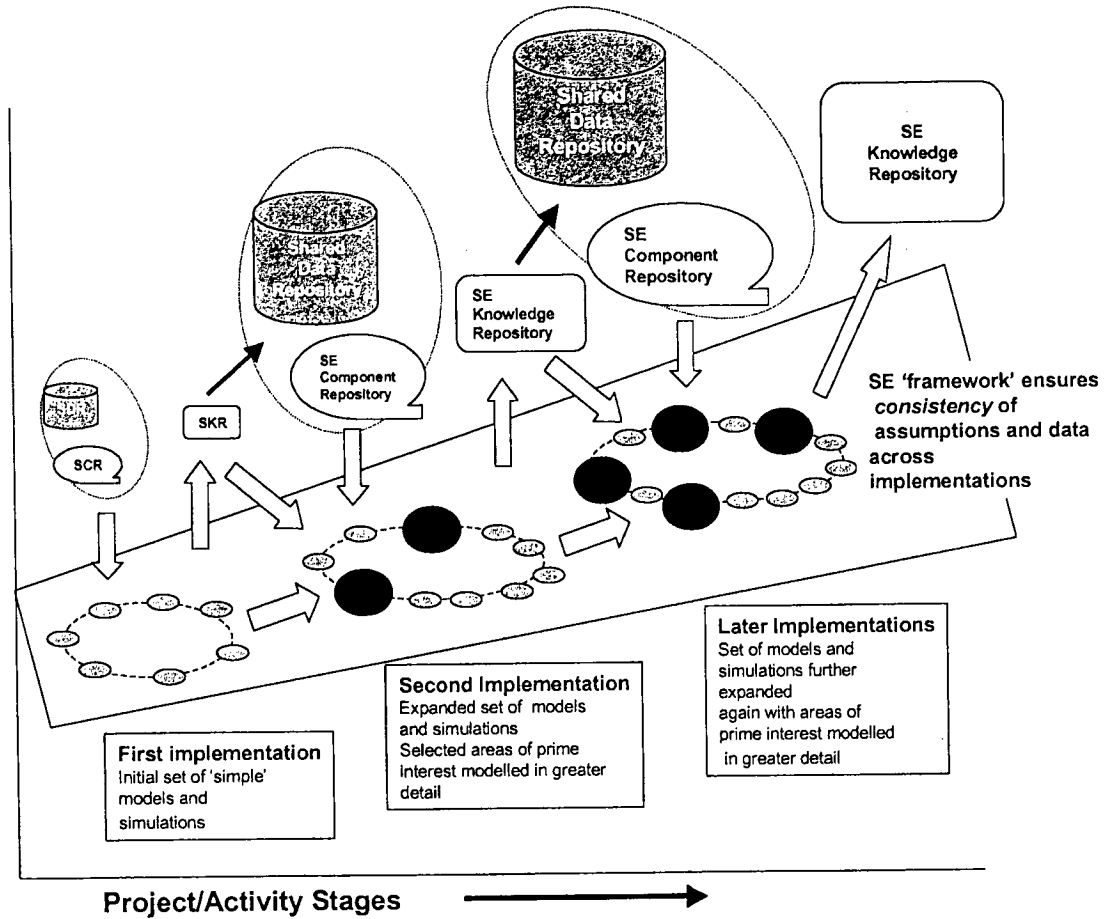

Figure 2-6: Evolution of Models and Simulation Throughout the Acquisition Stages [5]

³ This is a general tendency. Within the CEP, the risk levels will dictate the degree of fidelity of the models and simulations that need to be developed.

3. Modeling and Simulation in Acquisition

3.1 Simulation Based Acquisition (SBA)

The Symposium Working Group defined SBA as “an iterative, integrated product and process approach which capitalizes on the collaborative use of a robust suite of M&S tools by both the DND/CF and industry to ensure that the operator's materiel needs are satisfied. It is an acquisition methodology that can be applied to both “off-the-shelf” or “to-be-developed” equipment and systems. It involves the application of M&S across all functions and program phases, including identifying the required capability; preparing requests for proposal and evaluating bids; designing, developing, or modifying models or equipment; testing and evaluating the proposed solution; training operators; and ultimately, disposing of the system. The overall objective is to reduce acquisition time, resources, and risk.”[6].

Within the acquisition process developed in DND/CF, SBA acts as a vehicle to effectively coordinate the use of M&S to create a SE for concept development, experimentation, acquisition, test and training [3] and enables Integrated Product and Process Development (IPPD) across the entire life-cycle as presented in the previous section. Models and simulations can be re-used, integrated or linked together in order to meet the respective needs of the different acquisition phases.

Some of the main benefits expected from M&S are as follow [6]:

Information Credibility

When involved in the very early stages of acquisition, M&S can add to the completeness and the credibility of the information associated with the proposals presented to the decision makers. It allows an in-depth look at issues related to requirements and design, functionality, manufacturing, training, life-cycle support, etc. of a system. Various aspects of a capability can be simulated to help better estimate performance, effectiveness, potential problems, costs and risks. M&S allows the requirements definition process to be iterative which can help gather more complete, accurate and credible information early in the acquisition process.

Concurrent Processing

Early M&S involvement in the acquisition process also allows addressing multiple PRICIE (Personnel, Research and Development / Operational Research, Infrastructure and Organisation, Concepts, Doctrine and Collective Training, Information Technology Infrastructure, and Equipment, Supplies and Services) issues concurrently. As an example, training programs can be developed and tested out in virtual environments before new systems or equipments get delivered to the users. This not only allows minimizing the time to deploy the new equipment or system but it also helps future users build greater confidence.

Contracting

In its ability to allow multiple and complex option analysis, M&S can greatly help to evaluate the cost effectiveness of various solutions, thereby decreasing the time required to develop a Statement of Operational Requirements (SOR), and eventually the associated Statement of Work (SOW). Through the mean of its CEE, DND/CF believes it can work more closely with the manufacturing industry when performing requirements definition and functional analysis. As some related M&S activities could be conducted jointly in a collaborative environment, it is anticipated that better Requests for Proposal (FRP) would be developed and issued faster.

Test and Evaluation

M&S can strongly contribute in cutting down the costs associated with physical prototypes as various physical tests can be conducted in SE instead. Although physical tests will still be required, their objective will mainly be to validate the models developed. Once models have been validated, numerous virtual simulations can be executed at a fraction of the time and costs required to perform multiple physical tests.

“Additional benefits include the elimination of risks associated with safety hazards and the protection of the environment. Simulations can also help focus the test effort on the critical evaluation areas, thereby avoiding unnecessary physical testing. As well, testing in a virtual environment permits parallel, rather than sequential testing. All these possible benefits in the realm of T&E permit the fielding of materiel at a faster and potentially cheaper rate.” [6]

Table 1 was extracted from [5] and slightly modified to use the naming convention used in DND/CF for the acquisition phases. It summarizes how SBA, through the use of M&S, can provide benefits to the different phases of the acquisition life cycle. Activities in grey are potential candidates for the CEP (TBD).

Table 1: Applicability of M&S Through the Acquisition Phases [5]

PHASE OF LIFECYCLE	APPLICATION OF M&S	BENEFIT
<i>Identification of existing shortfalls</i> <i>(Pre-acquisition)</i>	Represent existing systems and test for a shortfall in capability. Demonstrate the consequences of the shortfall in capability.	Early and accurate assessment of capability shortfall.
Concept, Development and Experimentation (CD&E)	Demonstrate new concepts, including modes of operation, and assess modified or new equipment in future operational scenarios. Construction and presentation of robust business case.	Facilitates investigation of concepts including assessment of Operational Effectiveness (OE) (in conjunction with pre-existing systems). Enables feasibility assessment of concepts.

PHASE OF LIFECYCLE	APPLICATION OF M&S	BENEFIT
<i>(Pre- acquisition)</i> <i>Identification⁴</i>		concepts. Provides a mechanism to demonstrate Statement of Operational Requirements (SOR).
<i>Identification</i> <i>Option Analysis</i>	Demonstrate high-level system solutions including performance, logistics and through life costs. Facilitate refinement (de-risking) of concepts.	Enables assessment of capability over varied operational scenarios. Enables concept to be evaluated in an operational environment. Facilitates the refinement of the Statement of Operational Requirements (SOR).
<i>Definition</i>	Demonstrate the proposed options and down select the options for preparation of the Request For Quotation (RFQ). Establish the credibility of potential suppliers. Define the facilities to be used to evaluate the solutions offered in response to the RFQ. Support system design of the solution and the risk mitigation of the estimates used for the response to the RFQ.	Supports continued down selection of the options. Develops an objective base for the assessment of potential suppliers and the assessment of their performance to deliver an acceptable solution ready for in-service use. Defines the facilities and criteria that will be used to assess the acceptability of the equipment solution. Facilitates consideration of the options for supplying training, Mission Rehearsal & Planning (MR&P) facilities to meet the required in-service date.
<i>Implementation</i>	Support system design throughout the system and detailed design phases. Enables informed overview of the equipment manufacturing process. Provide a reference system for continuous monitoring of the key requirements included in the RFQ. Supports the test and integration of the solution by providing a comprehensive basis for fully exercising the design and ensuring that it meets the customer's requirement.	Provides a basis for monitoring the development, manufacture, test and integration of the selected solution as it progresses through the manufacturing phase. Support design & contract reviews. Enables assessment of the Training and MR&P facility and consideration of the implementation options. Provides a basis for monitoring the development, manufacture and test of the Training, MR&P facilities. Provide the test and demonstration environment for acceptance of the equipment and associated Training, MR&P facilities.

⁴ Some of the activities carried out during CD&E may also be potential candidates for CEP. This will be confirmed as CEP role gets better defined within CapDEM TD.

PHASE OF LIFECYCLE	APPLICATION OF M&S	BENEFIT
		Facilitate assessment of the methodology for introducing the equipment into service.
<i>In-service</i>	<p>Develop and modify support & maintenance strategies.</p> <p>Provide a fully integrated suite of Training facilities.</p> <p>Provide MR&P facilities.</p> <p>Facilitate the in-Service modification assessment and implementation.</p> <p>Provide a mechanism to monitor for evolving capability gaps.</p>	<p>Consider various support and maintenance options to meet the evolving operational requirements.</p> <p>Review the changes to the training needs and Training and MR&P facilities during the life of the system.</p> <p>Assess the options for equipment enhancements and their effectiveness to meet any new requirement or change of role.</p> <p>Assess the impact of the rolling upgrades upon the Training and MR&P facilities and support the implementation of changes to these facilities during the life of the system.</p>
<i>Disposal</i>	Assess the decommissioning options and develop a strategy for disposal.	<p>Provides a basis for assessing how the system is phased out and withdrawn from service.</p> <p>Assess environmental impact of disposal options.</p>

3.2 Benefits from early involvement of M&S in the acquisition life cycle

As previously stated, the primary objective of M&S is to provide tools and processes to better leverage risk throughout the acquisition process. In order to obtain the most benefits, M&S activities must be planned early in the process and properly managed across the different acquisition phases. This requires up front investment in terms of hardware and software infrastructure as well as direct and indirect resources and knowledge to efficiently plan, conduct, support and manage M&S activities.

The diagram in Figure 3-1, although not based on definitive numbers and outcomes, illustrates how major acquisition projects can benefit from the introduction of M&S at an early stage. Again, the figure's objective is only to show differences in the risk mitigation from using or not using M&S [5]. It should be noted that most of the benefits generated by the use of M&S during the CEP would only be observed in the subsequent phases of the acquisition process.

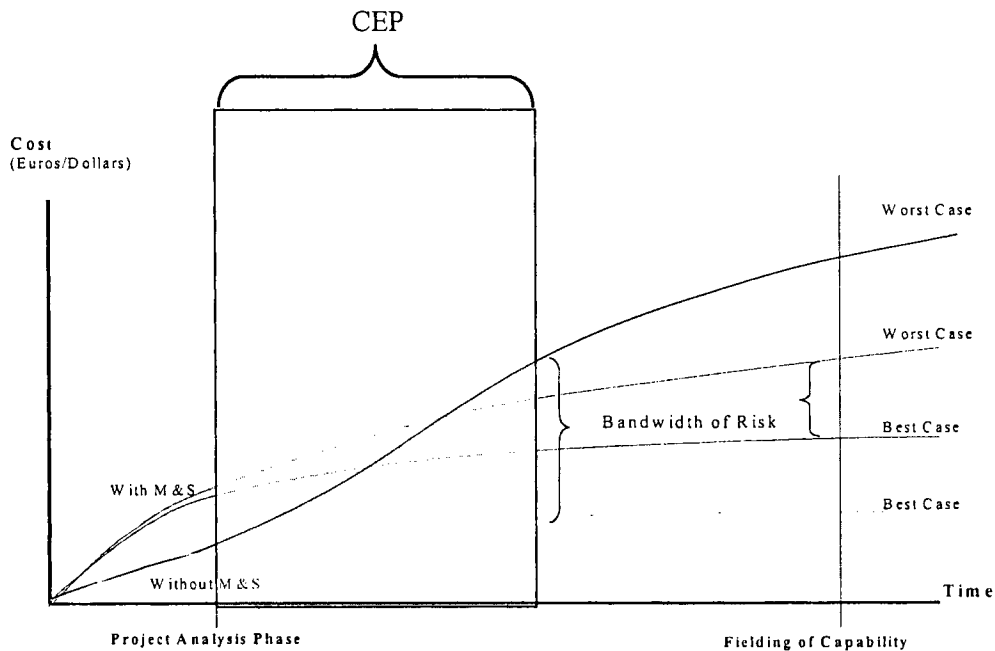

Figure 3-1: Justification for Investment in M&S for Major Acquisition Projects

3.3 M&S Fundamentals

3.3.1 Definitions

Model, simulation and M&S may respectively be described as follow:

- “A model is a physical, mathematical, or logical representation of a system entity, phenomenon, or process.
- A simulation brings a model to life and shows how a particular object or phenomenon will behave. It is useful for testing, analysis or training where real-world systems or concepts can be represented by a model.
- M&S provides virtual duplication of products and processes, and represents those products or processes in readily available and operationally valid environments.” [7].

M&S plays an essential role in helping CEP deliver greater quality, military worth and supportability of fielded systems while reducing Total Cost of Ownership (TCO) throughout the system life cycle.

The use of M&S within acquisition is a multi-dimensional activity which

- “supports the milestone decision process;
- supports multiple communities (operator, developer, designer, manufacturer, supporter, tester and trainer);
- consists of various classes and types of M&S each with a specific purpose.” [8].

3.3.2 Simulations Classes

Simulation tools are categorized in three (3) classes: *constructive*, *live* and *virtual*. From the definitions provided by DoD Executive Council for Modeling and Simulation (EXCIMS) [9], Table 2 presents each class along with its use in the military acquisition process.

Table 2: Classes of Simulations [9]

CLASS	DESCRIPTION / USAGE
Constructive	<p>“Constructive simulations are analytic models, implemented over time on a computer, that can range from detailed engineering models to highly aggregated theater/campaign⁵ simulations.</p> <p>Overall performance and/or behaviour of components, entities, systems, or collections of systems are predicted as a function of time and environmental stimuli. Some constructed simulations operate with little or no interaction from humans, whereas other constructive simulations, such as war games and training modules, are designed to interact directly with human participants.</p> <p>Constructive simulations may run slower than, at, or faster than real time, depending</p>

⁵ A model hierarchy description is provided in the next section.

CLASS	DESCRIPTION / USAGE
	on the particular use or function of the simulation."
Virtual	<p>"Virtual simulations are computer models that represent the physical structure as well as behaviour of a product or entity. They may represent the product or entity behaviour at either high or low detail, but are more often high fidelity, high-detail representations that evolve as the product progresses through the acquisition process.</p> <p>By modeling the physical structure of the product, virtual simulations bring the product and its operator together in a SE, allowing the operator to interface with, design, test, and train in a realistic, three-dimensional (3D) battlespace.</p> <p>Virtual simulations inherently run in real time so the product's responses to human actions can be evaluated."</p>
Live	<p>"Live simulations are full-up tests of systems or collections of systems in realistic battle environments. They are field training or test exercises involving real hardware, troops, and/or equipment.</p> <p>The test community uses constructive (and occasionally virtual) simulations to subject test articles to SEs that are otherwise untestable. The time span for live simulations is usually minutes to days."</p>

As Human-in-the-loop simulation refers to virtual simulations that bring a system or sub-system model and its operator together in a SE, Hardware/Software-In-the-Loop (HW/SWIL) refer to simulated equipment or platforms that are driven or stimulated by the output of computer simulations [8].

Virtual prototypes provide three-dimensional (3D) electronic representations of systems or sub-systems and allow individual to interface with them in a very realistic fashion within a SE [8].

The notion of Re-configurable Virtual Prototypes refers to prototypes that can represent more than one type of generic system. As an example, a low fidelity⁶ re-configurable prototype can be used to support training, combat development and system evaluation [17]. This is an important element to consider when it comes to develop a Simulation Support Plan⁷ (SSP), as it allows optimal use of the various M&S resources across the acquisition process.

A SE can be described as *"a composite environment, which includes a number of interacting systems and users; it may include real systems and people, constructive to virtual simulations and agents, to simple models. SEs may take many forms. Any combination of models, simulations, people, and real equipment/forces may be included and matched to the required purpose. The 'world' or context may represent a 'battlefield' or part thereof, using a mix of live, virtual, and constructive simulations. The operational context may cover current and future single or suites of scenarios. Equipment models may*

⁶ The concept of fidelity is described in the next sub-section.

⁷ SSP definition will be presented later in this section.

reflect user requirements alone or include system, design, and manufacturing considerations. They may be 'virtual prototypes' which allow designers and future operators to 'use' and examine proposed solutions in detail. Synthetically generated forces may represent large formations, single units, platforms, or individual soldiers. Participants in a SE may interact in the same 'world' regardless of their real world location" [6].

3.3.3 Hierarchy of Models and Simulations

The range of M&S is wide and varies in types, resolutions and purposes, from highly detailed engineering representation to aggregated representations of force-on-force engagements. In the military context, as illustrated in Figure 3-2, the range of M&S is mapped on a hierarchy where the scope evolves from very narrow at the bottom of the hierarchy (Engineering) to very broad when reaching the top (Theater/Campaign) [9].

The Engineering level, being the lowest one in the hierarchy, is normally characterized by high resolution of M&S which provides Measures Of Performance (MOP). The next two levels, Engagement and Mission/Battle, will provide Measures Of Effectiveness (MOE) through aggregated sets of models and simulations. Finally, the last level, Theater/Campaign, provides Measures Of Outcomes (MOO) from highly aggregated models and simulations.

In the context of M&S, the fidelity concept refers to the degree to which real world aspects are faithfully represented in models and simulations [10]. Although exceptions exist, the level of fidelity generally decreases as we progress from the engineering level to upper levels in the hierarchy. Such variety in resolution and scope allows M&S to support acquisition program activities that range from design to operational effectiveness assessments [8].

"The simulations and models hierarchy represent an integrated framework for analysis of performance, effectiveness, tactics and doctrine, and conflict outcomes. Each level in this integrated framework is aimed at addressing specific issues and relies on information obtained in analyses conducted at other levels" [8].

HIERARCHY OF MODELS AND SIMULATIONS

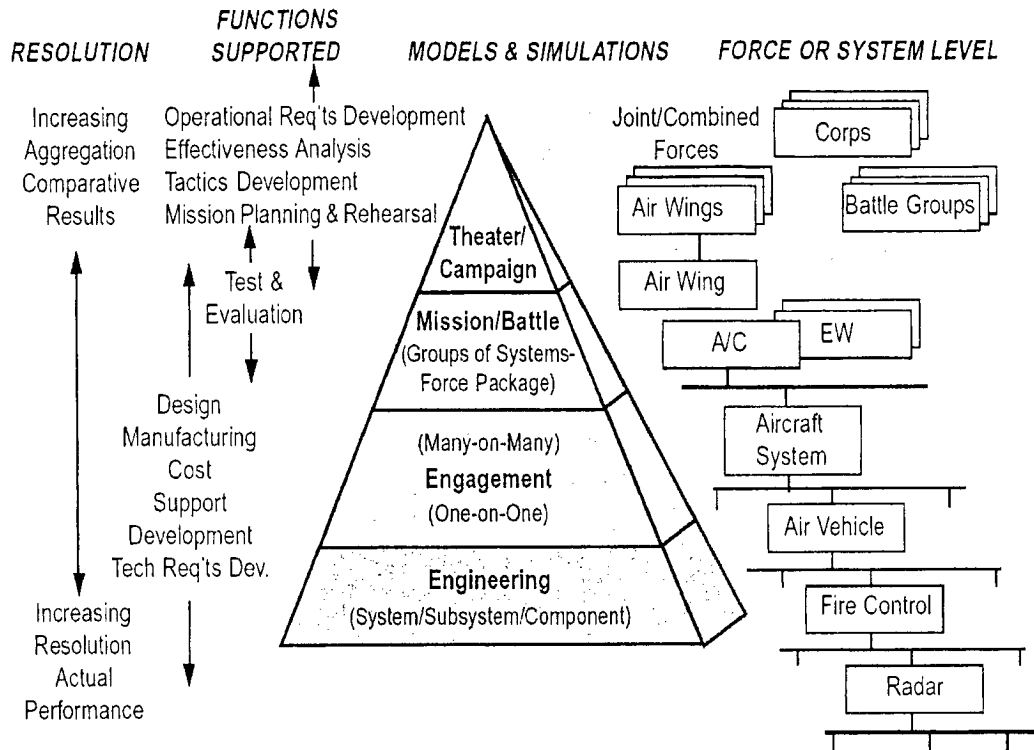

Figure 3-2: Hierarchy of Models and Simulations [8]

Table 3, created from [8] and [10], describes each hierarchy level along with its use in the acquisition process.

Table 3: Models and Simulations Hierarchy Descriptions [8] [10]

HIERARCHY LEVEL	M&S USE
Engineering	<p>Concerned with performance, productivity, supportability, cost of components, subsystems and systems, along with the inherent trade-offs analysis.</p> <p>In acquisition, Engineering level models and simulations provide MOP through models such as the following:</p> <ul style="list-style-type: none"> • Design models for trade-offs analysis at the component, subsystem and system levels (e.g. risk mitigation on performance); • Support models for development of technical design specifications; • Support models for T&E; • Costs models for development, production and operations and support; • Support models for reliability, availability and maintainability, level of repair and provisioning analysis; • Manufacturing models for design producibility.
Engagement	<p><i>"Represents the system in a limited scenario (one-on-one, few-on-few or sometimes many-on-many). Aims at evaluating the effectiveness of an individual platform and its weapons systems against a specific target or enemy threat system.</i></p> <p><i>These models relies on system performance, kinematics and sensor performance from the engineering models and simulations. They provides survivability, vulnerability and lethality results for measures of system effectiveness or for use</i></p>

HIERARCHY LEVEL	M&S USE
	<p><i>in higher level models."</i></p> <p>In acquisition, Engagement level models and simulations are use to provide MOE and MOP to support the requirements documents and Cost of Operational Effectiveness Analyses (COEA), system level performance trade-offs, test and evaluation support, and evaluation of tactics change and new weapon concepts.</p>
Mission/Battle	<p><i>"Reflects the ability of a multi-platform force package to accomplish a specific mission objective, such as air superiority, interdiction or strike which might span a period of hours.</i></p> <p><i>In conjunction with human participation, mission/battle level simulations may be used for war gaming, training and tactics development.</i></p> <p><i>Models and simulations are done at the package level rather than at the level of individual platform and its weapon systems. The outputs provided are MOE which may take the form of loss exchange ratios, probability of engagement or success in achieving a specific mission objective.</i></p> <p><i>In acquisition, Mission/Battle level models and simulations include analysis in support of requirements, operational effectiveness analyses for alternatives in COEAs, examination of interoperability and compatibility issues and support in test and evaluation."</i></p>
Theater/Campaign	<p><i>"Theater/Campaign models and simulations represent force combat operations and are used to determine the long term outcome of a major theater or campaign level conflict. Forces are often represented as aggregations of lower level forces and systems. These models and simulations can identify major deficiencies in capabilities of force structures and employment alternatives."</i></p> <p>Such models and simulations often rely on lower level models and simulations as input to generate the aggregated-force level capabilities. They may be used as a wargaming tool for battle staff training or tactics development.</p> <p>Theater/Campaign levels models and simulations are used to provide MOO expressed by force drawdown, battle group losses, air superiority and ground force movements.</p> <p>In acquisition, Theater/Campaign levels models and simulations include evaluation of force level combat outcomes in conducting missions, support of COEAs and evaluation of impacts of new systems or operational concepts.</p>

A proper understanding of the hierarchy just described is essential in order to integrate and link M&S with CEP. The integration and linkage occurs throughout the acquisition life cycle and across functional disciplines without excessive M&S use, duplication of effort, and allows future growth and expansion [17].

As previously mentioned in Section 2, a DPD must keep the system design (physical) and the behaviour (performance) views synchronized at all time. As stated by Eirich and Coolahan [3], the DPD will maintain data related to all levels of modeling, from the Engineering level to Theater/Campaign level. Although the DPD will contain the design of a capability with the basic information of its systems and sub-systems, the basic models of physics or fundamental technologies would typically be kept outside the DPD. Instead, the DPD would maintain the fundamental engineering characteristics that

would be used in models and simulations to estimate performance. The performance measures obtained would then be fed back into the DPD for use in M&S at the next level of aggregation, in a “bottom-up” approach, as shown by Figure 3-3.

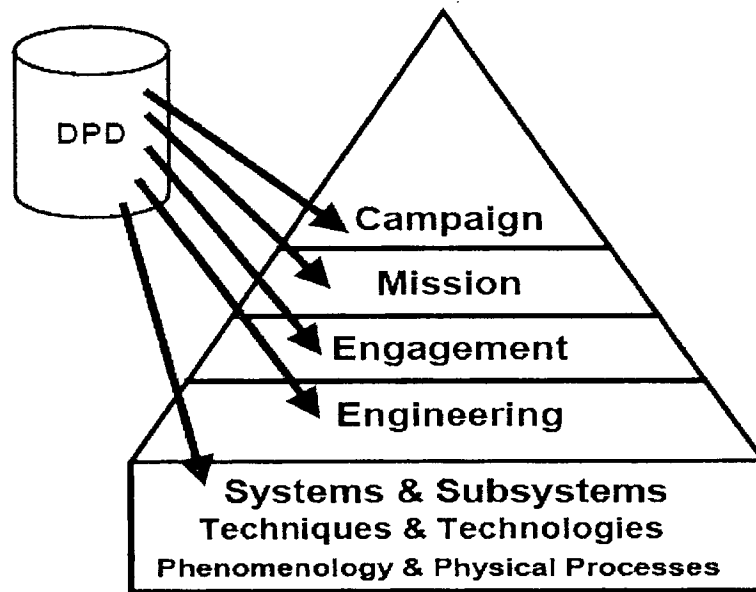

Figure 3-3: Linkages between the DPD and the M&S Hierarchy [3]

Table 4 summarizes the main attributes and uses of models and simulations within the hierarchy previously described [8].

Table 4: Attributes and Uses of Models and Simulations Within The Hierarchy [8]

LEVEL OF MODEL	Engineering	Engagement	Mission/Battle	Theater/Campaign
FORCE	Single Weapon Systems, Subsystems, Components	One to a Few Friendly Entities Vs. one to a few Enemy Entities Engagement	Multi-Platform, Multi Tasking Force Package	Joint/Combined
LEVEL OF DETAIL	Highly detailed - down to individual piece parts, their interaction & phenomenology	Individual entities Detailed subsystems	Some Aggregation or Individual Entities	Highly Aggregated Down to Individual Entities (Tank, Ship, A/C)
TIME SPAN	Months - Sub-Seconds	Minutes-Seconds	Hours-Minutes	Weeks-Days
OUTPUTS	<ul style="list-style-type: none"> Measures of <u>Performance</u> of System, Subsystems, & Components (e.g. Miss Distance, target acquisition range) Cost, Supportability, Producibility 	<ul style="list-style-type: none"> System <u>Effectiveness</u> (e.g. Probability of Kill, Losses, Aborts, Survivability, Vulnerability) 	<ul style="list-style-type: none"> Mission <u>Effectiveness</u> (e.g. Loss exchange ratios, probabilities of Engagement) 	<ul style="list-style-type: none"> Campaign <u>Outcome</u> (e.g. Air Superiority, Force Drawdowns, Ground Force Movements)
USE	<ul style="list-style-type: none"> Design Subsystem & Component Performance & Tradeoffs Specification Requirements & Compliance Cost, Support, Producibility Test Support Facilitate IPPD 	<ul style="list-style-type: none"> Alternative Eval (COEA) Requirements (MNS, ORD) System Effectiveness System Tradeoffs Tactics, rules of Engagement Test Support 	<ul style="list-style-type: none"> Alternative Eval (COEA) Requirements (MNS, ORD) Deployment Weapons Integration Interoperability Tactics & Ops Concepts Training & Wargaming 	<ul style="list-style-type: none"> Alternative Eval (COEA) Requirements (MNS, ORD) Tactics/Employment Wargaming Battle Staff Training Sustainment Issues
EXAMPLES (Typical Uses)	<p>Many, throughout R&D Centers, Labs, Contractors, such as:</p> <p>6-DOF CAD/CAM HW/SWIL Cost Factory simulation Support (LORA, RAM)</p>	<p>Eagle, Janus</p> <p>SSTORM</p> <p>Brawler, ESAMS</p>	<p>Janus, Eagle</p> <p>WEPTAC, SIM II</p> <p>Suppressor, EADSIM</p>	<p>Campaign Exercise Model</p> <p>ENWGS, CAAM</p> <p>AWSIM, Thunder</p> <p>MTWS</p>

3.3.4 Relationship of Models and Simulations

As stated previously, the hierarchy of models and simulations allows the aggregation of lower level models and simulations in support to the higher level ones. As summarized in Figure 3-4, Engineering level models provide MOP along with design, cost, producibility and supportability information for component, subsystem and systems as Engagement and Mission/Battle models provide the military utility of the system. At the highest level, Theater/Campaign level models provide MOO for major conflicts involving combined forces. Finally, Human-in-the-loop, virtual simulations and virtual prototypes can interact at all levels in the hierarchy to provide information [8].

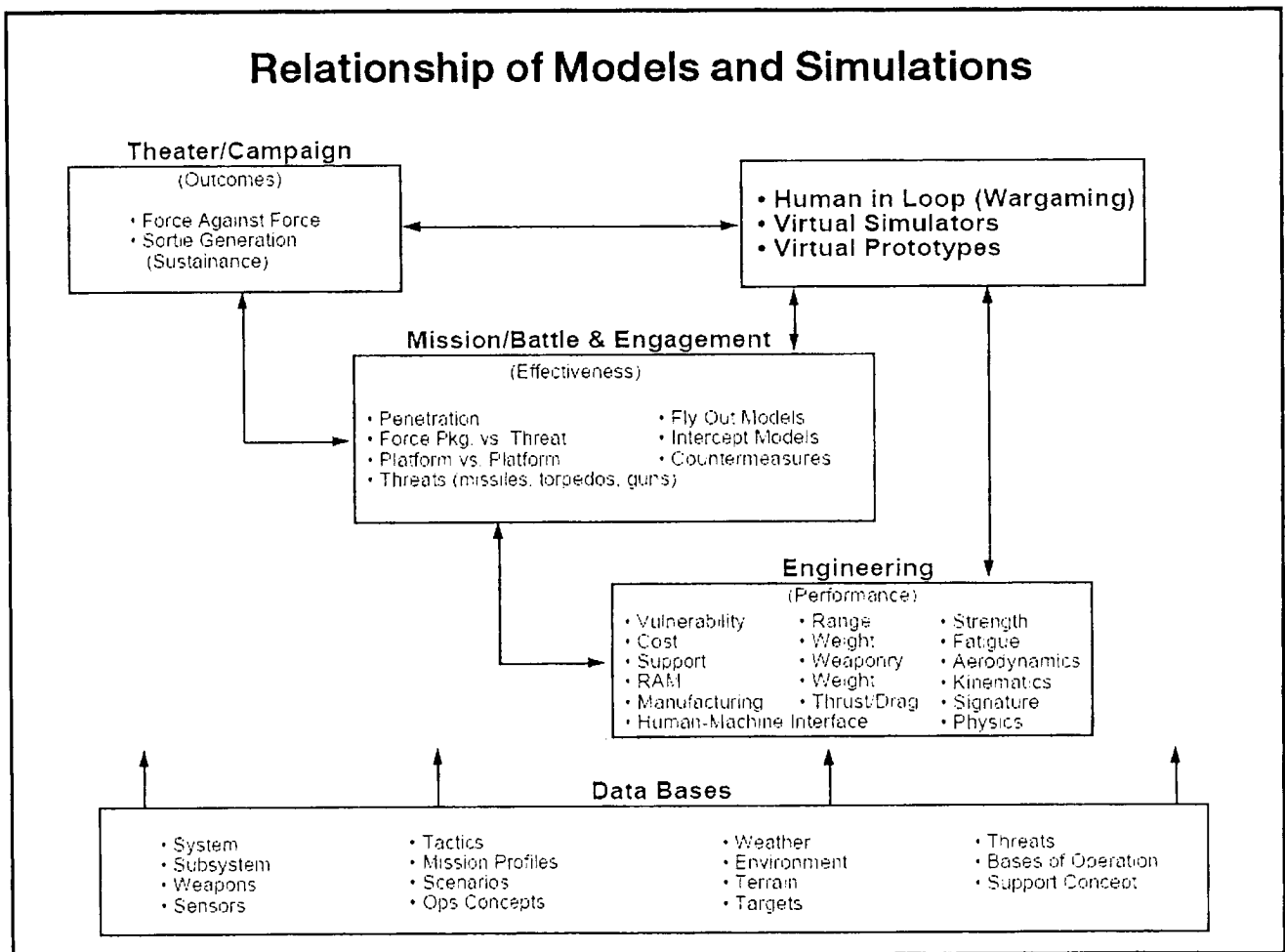

Figure 3-4: Relationship of Models and Simulations [8]

3.3.5 M&S functional domain areas

This section briefly presents some of the key functional domain areas supported by M&S throughout the acquisition process. These functions are Requirements Analysis, Analysis of Alternatives (AoA), Wargaming/Combat Development, Design and Engineering, Test and Evaluation (T&E), Manufacturing, Training, Logistics Support and Program Management.

For further details, the reader is invited to consult the following documents:

- System Acquisition Manager's Guide for the use of Models and Simulations [8];
- Acquisition Modeling and Simulation Comprehensive Core Body of Knowledge (CCBK) [12].

The content of Table 5 was extracted from [8] and [12] documents:

Table 5: M&S Key Functional Domain Areas

FUNCTIONAL AREA	DESCRIPTION	M&S ROLE
<p>Requirements Analysis</p>	<p>Requirement analysis goal is to translate user requirements into performance specifications. In order to achieve this, a suite of models and simulations is likely to be used, ranging from engineering performance to Theater/Campaign levels.</p> <p>Note: This activity is usually initiated during the Concept and Development Phase (CD&E) in pre-acquisition and gets refined in the acquisition process.</p>	<p>Analysis will be conducted at each level of the M&S hierarchy in order to evaluate various scenarios, systems and tactics.</p> <p>The analyses are repeated from a variety of operational concepts and each of the system option under consideration. The engagement, mission and campaign models may be run iteratively to provide statistical significance of outcomes.</p> <p>Engineering level models provide:</p> <ul style="list-style-type: none"> • Performance estimates for existing or improved capability systems taking into account the emerging technology opportunities; • Evaluation of performance and trade-offs of system and sub-system design concepts and technologies; <p>Engagement and mission level models allows:</p> <ul style="list-style-type: none"> • System/subsystem performance capabilities to be evaluated for their level of effectiveness in a limited engagement or mission; <p>Theater/Campaign level models provides:</p> <ul style="list-style-type: none"> • Measures of outcomes in terms of force exchange ratios, drawdowns or troop movements for the analyzed capabilities when confronted with effects of force mix, tactics or new capabilities.
<p>Analysis of Alternatives (AoA)</p>	<p>Analysis of alternatives aims at comparing, throughout a trade study process, alternative system design concepts in order to identify the most cost effective solution to fulfill the</p>	<p>M&S supports AoA in three areas: requirements, military capability and acquisition. The acquisition process includes performance studies, effectiveness studies, trade-off analysis, risk analyses, sensitivity analyses and</p>

FUNCTIONAL AREA	DESCRIPTION	M&S ROLE
	capability deficiency. The AoA will help validate requirements as well as the military worth of each solution expressed in terms of cost, schedule and performance.	cost analyses. No one general model of set of models is used for all AoAs.
<i>Wargaming / Combat Development</i>	Distributed Interactive Simulations (DIS) is used in wargaming and combat development in order to support mission area assessment that include force-on-force simulations.	M&S effort focuses on performance, effectiveness, and theater/campaign level outcomes that assist in determining operational mode tempo, crew and system size, structure, and force ratio.
<i>Design and Engineering</i>	<p>A large spectrum of models and simulations is available to address the various disciplines involved with design and engineering.</p> <p>Different models and simulations allow to modify designs, analyze the effects and refine the design repeatedly prior to building a single hardware prototype.</p>	The scope of engineering development includes M&S activities ranging from detailed design analysis to supportability, manufacturability and affordability. As the design concepts evolve and the level of details increases, M&S provides better estimates of performance for alternatives designs.
<i>Test and Evaluation (T&E)</i>	<p>T&E provides pertinent information to support risk assessment and decision-making. It also helps verify attainment of technical performance specifications and objectives, and verify that systems are operationally effective and suitable for their intended use.</p> <p>Test planning is initiated early in the life cycle.</p> <p>The integration of M&S within T&E enables a "Model-Test-Model" approach which provides the following benefits:</p> <ul style="list-style-type: none"> • Ensure the models and simulations still meet the developer's needs; • Use models and simulations to identify critical tests, data requirements, analyze data and reduce the amount of actual testing; and • Ensure every test serves the dual purpose of evaluating system performance and validating the models and simulations. 	<p>Efficient use of test resources is the overall goal of M&S for testing. The integration of M&S in the testing strategy will help reduce field test assets, resources, test iterations and test duration. M&S is used across test planning, test execution along with post-test efforts.</p> <p>In test planning, M&S will help determine the minimum set of necessary live firings as in test execution, it will be used to evaluate on-line changes to variations in the force structure, doctrine, tactics, techniques, etc., and their impacts to overall weapon system performance. Finally, post-testing will use M&S to allow sensitivity analysis for final system evaluation.</p> <p>M&S also allow evaluation of environmental restrictions and safety constraints. The final product can be evaluated for its testability through M&S prior to actual testing in the test ranges.</p> <p>Simulations are used to bridge the gap between the ever-increasing data requirements and the relatively constant, or even decreasing available test assets.</p>
<i>Manufacturing</i>	The objective of Manufacturing is to design and develop the manufacturing process in the most economical manner possible.	M&S support the Manufacturing process through a virtual manufacturing environment. This approach allows the translation of operational requirements, previously obtained from a synthetic battlefield environment, into design concept in the form of three-dimensional virtual simulations. These designs are then passed along to a network of distributed manufacturing simulations, which may reside throughout a vendor base, to identify the manufacturing processes, facilities and tooling

FUNCTIONAL AREA	DESCRIPTION	M&S ROLE
		<p>requirements. The cost and schedule estimates obtained from the vendor base can be fed back into the cost and schedule models and simulations to refine estimates.</p> <p>The same cost and schedule estimates can also support trade-offs and the system level alternative evaluations in the COEA.</p>
<i>Training</i>	<p>Training is integral to achieving and maintaining force readiness. As for T&E, training must be planned early in the acquisition phase and manage across all phases.</p>	<p>The use of M&S with regards to training ranges from developing the training requirements and devices to individual, crew, and unit proficiency training.</p> <p>During early acquisition, the training M&S are primarily focused on front-end training analysis, training device performance, and human integration issues. M&S assists in identifying initial training resources, tradeoffs, requirements, and training devices which will affect the combat development and engineering development functional areas.</p> <p>Efficient M&S planning will allow the system training devices developed to be used before and after the deployment of the system.</p> <p>Part of the training functional area is the exercise support which includes M&S supporting wargames and force level scenario development, training and doctrine defined at the Theater/Campaign level. Combination of live, virtual and constructive simulations allow personnel to conduct mission planning, rehearsal and individual/staff skill development through Distributed Interactive Simulations (DIS).</p>
<i>Logistics Support</i>	<p>In the delivery of a new capability, logistics analysis aims at defining system level supportability concept to reliability, availability and maintainability. Logistic support must also evaluate levels of operational capability during operations and support.</p>	<p>In support to logistics analysis, models and simulations are used across the system life cycle to help balance the design of the new capability with its overall operations and support costs. Early activities include comparison analysis between the baseline and the new system to identify supportability, cost and readiness drivers, and estimate the operations and support portion of the life cycle costs.</p> <p>Level Of Repair Analysis (LORA) models helps perform trade-offs analysis with regards to manpower, reliability, availability and maintainability. It also allows to evaluate alternate maintenance concepts and their effects on supportability for specific subassemblies.</p> <p>Integrated Logistics and Support (ILS) and Logistics Support Analysis (LSA) benefit from an assortment of models and simulations that allow greater flexibility in estimating the impact</p>

FUNCTIONAL AREA	DESCRIPTION	M&S ROLE
		on logistics support and costs when changes affecting the new capability arise.
Program Management	Program management is faced with balancing cost, schedule and performance throughout the delivery of a new capability. In support to these tasks, M&S use primarily focus on the performance or military utility arena.	<p>Many models used for program management are actually database or knowledge-based tools. Various cost models are also developed to perform program life cycle estimates along with costs estimates for alternatives evaluation (e.g. COEA) to support milestone decisions.</p> <p>As for the use of M&S in other functional areas of the acquisition process, each program must properly assess its needs and identify what suite of models and simulations will most likely suit the program's objectives.</p>

3.3.6 M&S Policy/Guidance

DND/CF supporting policy and guidance for M&S can be found on the DND Synthetic Environment Coordination Office (SECO) website at: http://www.drdc-rddc.dnd.ca/seco/index_e.html

At the writing of this report, SECO's website provided a small amount of information on M&S policy/guidance. The website's main topics were as follow:

Policy & Standards http://www.drdc-rddc.dnd.ca/seco/policy_standards_e.html

- DAOD 8008-0: Modeling and Simulation (To Be Published)
- DAOD 8008-1: Modeling and Simulation Management (To Be Published)

Best Practices http://www.drdc-rddc.dnd.ca/seco/best_practices_e.html

Library http://www.drdc-rddc.dnd.ca/seco/library_e.html

Modeling and Simulation Resource Repository (MSRR) http://www.drdc-rddc.dnd.ca/seco/msrr_e.html

Links http://www.drdc-rddc.dnd.ca/seco/links_e.html

Societies http://www.drdc-rddc.dnd.ca/seco/societies_e.html

Events http://www.drdc-rddc.dnd.ca/seco/events_e.html

3.3.7 M&S Related Processes

Table 6 briefly presents some of the processes that are generally considered essential to a successful application of M&S. For further details, the reader is invited to consult the document “*Acquisition Modeling and Simulation Comprehensive Core Body of Knowledge (CCBK)*” [12].

Table 6: M&S Supporting Processes

PROCESS	DESCRIPTION
<p>Integrated Product and Process Development (IPPD)</p>	<p>“IPPD process aims at integrating all activities, from product concept through production and field support, using multi-disciplinary teams to simultaneously optimize the product and its manufacturing and supportability to meet cost and performance objectives.</p> <p>M&S supports IPPD process and the integration of complex systems. It is also a key tool to the Integrated Project Teams (IPT)” [12].</p>
<p>Cost as an Independent Variable (CAIV)</p>	<p>In order to reduce the overall acquisition life cycle costs, DoD 5000.1 (4.5.2) indicates that cost must be viewed as an independent variable a treat as a military requirement. Therefore, each Department must establish the total cost it is willing to invest to obtain, operate and support the needed capability over its expected life cycle.</p> <p>The following approach summarize the required elements needed to achieve the objectives of CAIV [12]:</p> <ul style="list-style-type: none"> • Set realistic but aggressive cost objectives early in each acquisition program; • Manage risks to achieve cost, schedule and performance objectives; • Motivate and incentivize government industry managers to achieve program objectives; • Put in place for fielded systems additional incentives to reduce operating and support costs.
<p>Simulation Support Plan (SSP)</p>	<p>Efficient use of M&S requires proactive, early, continuous and regular planning [7]. This planning takes the form, particularly, of a Simulation Structure Plan document which provides a tool to identify M&S requirements in order to develop a M&S strategy across the acquisition life cycle [17]. At a minimum, the M&S strategy should explain how models and simulations will be used to:</p> <ul style="list-style-type: none"> • support life cycle cost analyses and cost trade studies, • reduce program risk, • support design and development, • address interoperability issues, • focus and support the T&E strategy, • determine logistics and support (sustainment) requirements, and • focus the training strategy and support training activities <p>The SSP defines how and when M&S will be used to mitigate risk, reduce cost and schedule, and improve system performance, training aids, manufacturing processes, and system supportability.</p> <p>As per Fallin [17], the SSP is developed by analyzing the external and internal risks inherent to the acquisition project, then selecting and organizing a combination of live, virtual and constructive M&S consistent with the program acquisition strategy⁸. As external risks are determined by gathering information on factors affecting the program cost, schedule and performance, internal risk refers to the level of risk in developing the various model and simulations, and their credibility in the use of their outputs to enhance the program development</p>

⁸ The program acquisition strategy should be aligned on the DND SECO M&S Policy.

PROCESS	DESCRIPTION
	<p>in a timely and cost effective manner.</p> <p>The SSP is a living plan which is tightly linked to the acquisition strategy and its related phases and activities. The SSP will particularly provide the following information [17]:</p> <ul style="list-style-type: none"> • How M&S will be used to meet specific acquisition objectives (e.g. risk reduction in cost, schedule and performance); • How requirements will be mapped to required M&S tools, and communicated to the modeling community providing M&S support; • How constructive, virtual and live models and simulations will be used to obtain an End-to-End suite of simulations supporting the engineering development; • Linkage and integration⁹ of M&S across functional areas and program phases; • Maturing of models as the program progresses; • M&S resources requirements (personnel, facilities/equipment, terrain requirements, security requirements, etc.); • VV&A¹⁰ activities; • Funding requirement.
<p>Verification, Validation and Accreditation (VV&A)</p>	<p>VV&A's goal is "to gain confidence of user organizations that M&S outcomes are representative of the real world, that they are reasonably correct, and that the models and simulations are acceptable for the specific purpose for which they will be used" [17].</p> <p>More specifically, according to DoD System Engineering Fundamentals [7]:</p> <ul style="list-style-type: none"> • "Verification is the process of determining that a model implementation accurately represents the developer's conceptual description and specification that the model was designed to." • "Validation is the process of determining the manner and degree to which a model is an accurate representation of the real world from the perspective of the intended uses of the model, and of establishing the level of confidence that should be placed on the assessment." • "Accreditation is the formal certification that a model or simulation is acceptable for the use for a specific purpose. Accreditation is conferred by the organization best positioned to make the judgment that the model or simulation in question is acceptable. That organization may be an operational user, the program office, or a contractor, depending upon the purposes intended." <p>As the output data obtained from models and simulations are used to feed analyses supporting decision-making across the acquisition process (e.g. system requirements, design and engineering, manufacturing, T&E, logistics support, etc.), VV&A is an essential process to ensure credible information is acquired from M&S activities [8].</p> <p>VV&A is applied at initial development and use of any M&S. Whenever existing models and simulations undergo a major upgrade or modification, or violates the documented methodology or inherent boundaries used to perform verification or validation, VV&A must be redone [7].</p>
<p>Configuration Management (CM)</p>	<p>In the context of M&S, "CM is critical to maintain the credibility of models and simulations over time, ensure its continued compliance with standards to which it was designed and ensure its overall utility to the program. A CM plan for a model must ensure controls for the model itself, its development process and the input data." [7].</p>

⁹ As per [7], "Integration is obtained by designing a model or simulation to inter-operate with other models or simulations for the purpose of increased performance, cost benefit, or synergism."

¹⁰ Verification, Validation & Accreditation (VV&A) is described next.

PROCESS	DESCRIPTION
	<p><i>"CM is defined as a discipline applying technical and administrative direction over the life cycle of an item to:</i></p> <ul style="list-style-type: none"> • <i>Identify and documents the functional and physical characteristics of the item and its major parts;</i> • <i>Control changes to these parts and to their related documentation;</i> • <i>Establish a process for maintaining status of proposed changes, implementation status of approved changes, etc.; and</i> • <i>Establish a process for conduct of audits to verify conformance of item's (and its major parts') design and performance with requirements documentation" [7].</i> <p>The previous description is applicable to any hardware, software or firmware configuration item.</p> <p>M&S configuration management will provide the following benefits:</p> <ul style="list-style-type: none"> • <i>Facilitate repeatability by maintaining a record copy of an M&S used in providing information to support analysis, along with its associated input data.</i> • <i>Enable traceability by maintaining a clear audit trail of the changes to a model and input data which provides a mechanism to correlate each change to the circumstance(s) generating the requirement.</i> • <i>Maintains credibility of a model and its data.</i> • <i>Maintains interfaces between models by identifying and controlling changes that may affect the level of integration or interoperability of a suite of models and/or simulations.</i>
<p><i>Simulation, Test and Evaluation Process (STEP)</i></p>	<p><i>"STEP integrates M&S with test and evaluation (T&E) in order to promotes a "model, simulate, fix, test, iterate" approach and allow problems to be fixed as they are discovered throughout the system development.</i></p> <p><i>With STEP, the set of models matures culminating in representations of the system, its interfaces, and its environment with an established fidelity. When tests are conducted, the data collected while evaluating the system can be used to refine and validate the models. The models and simulations can then be reused throughout the acquisition life cycle." [12].</i></p>
<p><i>Test and Evaluation Master Plan (TEMP)</i></p>	<p>TEMP specifies the necessary tests and evaluation activities for development, operation and live fire. It relates program schedule, test management strategy and structure, and required resources [12].</p> <p>M&S supports TEMP in providing decision-maker with relevant information on effectiveness, suitability, survivability, and in estimating the degree of mission accomplishment. During T&E planning, M&S can extend the knowledge of the system beyond circumstances that can be tested and validate models and simulations to be used in the T&E of the system.</p>

3.4 Tools

M&S encompasses a very large number of tools and technologies that can be exploited throughout the capability life cycle. It is not within the scope of this report to provide a comprehensive tool survey. Rather, this section will present the different M&S tool categories that may be considered in supporting the CEP along with some product examples. Some links to M&S tool catalogues and vendors are also provided.

Annexe A provides some links to M&S Tools websites.

3.4.1 Modeling tools

Within the different CEP activities, modeling tools can be used to describe the “*who, what, when, why and how*” by depicting organizational structures, entities, relationships, business processes, functional decompositions, information flows, and resource usage. All together, these models provide a common view to the stakeholders as to how an organization delivers its functions. Weaknesses and shortfalls can be identified from the models developed, and from there, further modeling can be done to reengineer the organization in order to obtain greater functionalities and/or efficiency, or to satisfy new requirements.

To help with the modeling of the various facets of an organization, many general-purpose drawing software tools are available. Among them, some also provide analysis tools to estimate resource usage, costs, or functional execution timelines (this functionality is often exploited in the context of simulations).

Rich Computer-Aided System Engineering (CASE) tools are provided by Business Process Analysis (BPA) software to support the modeling, the analysis and the reengineering of business processes within an organization. Gartner’s latest report on BPA [56] states that this market is still very active at meeting a growing demand from organizations interested in keeping their business processes agile and optimized. As BPA tools were traditionally used to produce documentation and static models, they are now providing methods, tools and techniques to efficiently “model business process alternatives on the front end of the process development cycle, as well as optimization of live processes through near-real-time feeds” [56]. Business simulation is now available in what is termed “round-trip engineering” (model → simulate → adjust → implement → measure → simulate) [56].

Leading BPA vendors offer product solutions that address organizational needs in a holistic fashion through various sets of integrated tool suites that encompass the essential aspects of business process analysis and management. The functionality provided by BPA products include the following:

- Requirement definition;
- Organizational modeling;
- Business process modeling;
- Integrated Technology architecture modeling;
- Data modeling;
- Data flow modeling;
- Matrix analysis;
- UML modeling support;
- IDEF design support;
- Object modeling (with extended properties such as metrics, costs and documents);
- Model-based implementation;
- Integrated reporting;
- HTML publishing;
- Import/Export functions (e.g. Word, Excel, PowerPoint, XML);
- Impact analysis;
- Process simulation;
- Collaborative environment through centralized object repository (promotes object reuse and sharing among users);
- Enterprise architecture frameworks modeling (Zachman, C4ISR, TOGAF, etc.);
- Integration with other Business Process Management (BPM) and development tools such as Telelogic DOORS [37], CA Erwin [38], MS Visio [39], IBM Rational Rose [40], Oracle [41], Sybase [42], and others; and
- Performance management and balance scoreboard.

Figure 3-5 summarizes the current BPA market depicted by Gartner's Magic Quadrant.

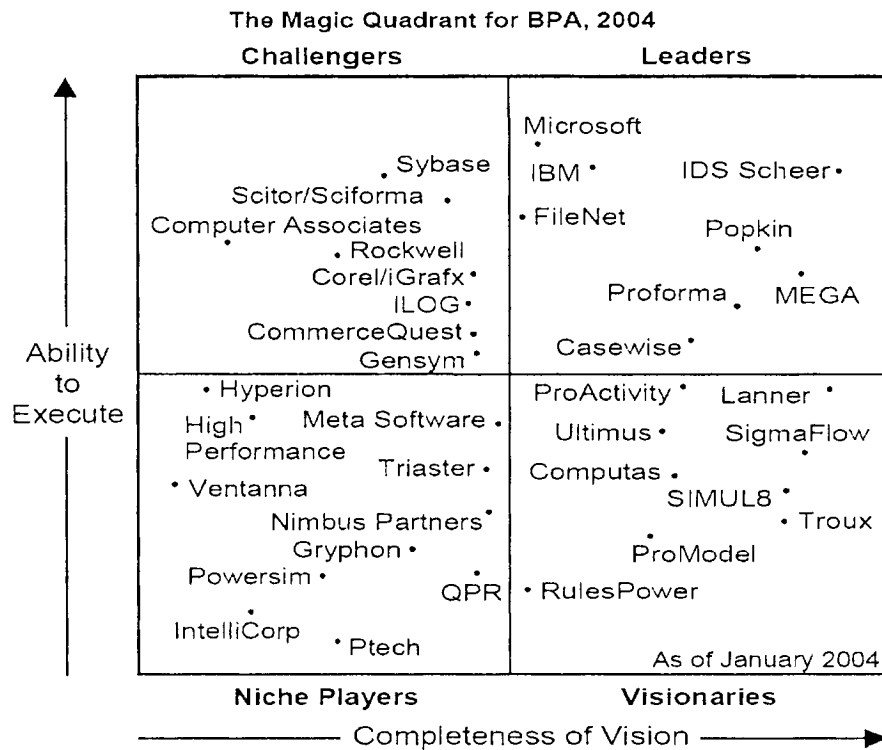

Figure 3-5: Gartner Magic Quadrant For BPA, 2004 [56]

Gartner, Inc.'s, Magic Quadrant is a graphical representation of vendor performance in a market segment. The vertical axis of the quadrant indicates the vendor's ability to execute on its strategy and the horizontal axis indicates the vendor's completeness of vision. Each of the four squares of the quadrant are named to characterize the vendors placed in those areas: lower left square is labelled Niche Players, lower right square is Visionaries, upper left square is labelled Challenger, and upper right square is Leaders. Gartner defines the four segments as follows [56]:

- Leaders are performing well today, have a clear vision of market direction and are actively building competencies to sustain their leadership position in the market
- Visionaries have a clear vision of market direction and are focused on preparing for that, but they can still improve in terms of optimizing service delivery
- Challengers execute well today, but have a less-defined view of market direction and, therefore, may not be aggressive in their preparation for the future
- Niche Players focus on a particular segment of the client base, as defined by characteristics such as size, vertical or project complexity. Their ability to outperform or innovate may be impacted by this narrow focus

The BPA vendors' process change approach for business reengineering is very similar to the approach that defined for the CEP so far. Perhaps, further

product analysis would help better estimate the benefits and potential shortfalls from using these CASE tools in the context of capability engineering.

So far, there seems to be a growing interest for these CASE tools in the military acquisition as we have seen the US Government (DoD) adopt Popkin's System Architect® software to help its Agencies and Contractors provide system documentation that is more homogeneous and compliant with C4ISR11 standards [43] [44] [45]. The following figures (Figure 3-6, Figure 3-7, Figure 3-8, Figure 3-9 and Figure 3-10) provide some examples of the tools and processes offered by BPA vendors.

The process of change with Corporate Modeler

Capture the 'as-is' situation	Experiment with 'what-if?' scenarios	Implement the 'to-be' model	Manage processes and architecture
Create and analyze an accurate visual model of your current operations using Corporate Modeler's multi-dimensional modeling	Analyze and simulate your processes to find bottlenecks and ways to increase efficiency and performance	Communicate your final agreed blueprint across management, IT and front-line staff to ensure detailed understanding and successful implementation	Automatically generate an on-line process management portal to train and support your front-line staff in executing processes.
Validate the accuracy of your model through automatic HTML publishing and report generation.	Create 'what-if?' scenarios and simulate the ROI of change to find an optimal blueprint for organizational improvement.	Transfer process and data designs directly into leading development and workflow tools to generate supporting systems.	Continually analyze your processes to identify 'best-practice' processes and roll these out across the organization.

Figure 3-6: Re-engineering Process Implementation¹² (Casewise) [46]

¹¹ C4ISR stands for Command, Control, Communications, Computers, Intelligence, Surveillance and Reconnaissance. It is an architecture framework that allows a unified approach for the development and evaluation of military information and architecture.

¹² The essential elements of this re-engineering process are very much like to the CEP approach towards capability. Such process, along with similar ones proposed by other BPA vendors, depicts quite simply what BPA is all about.

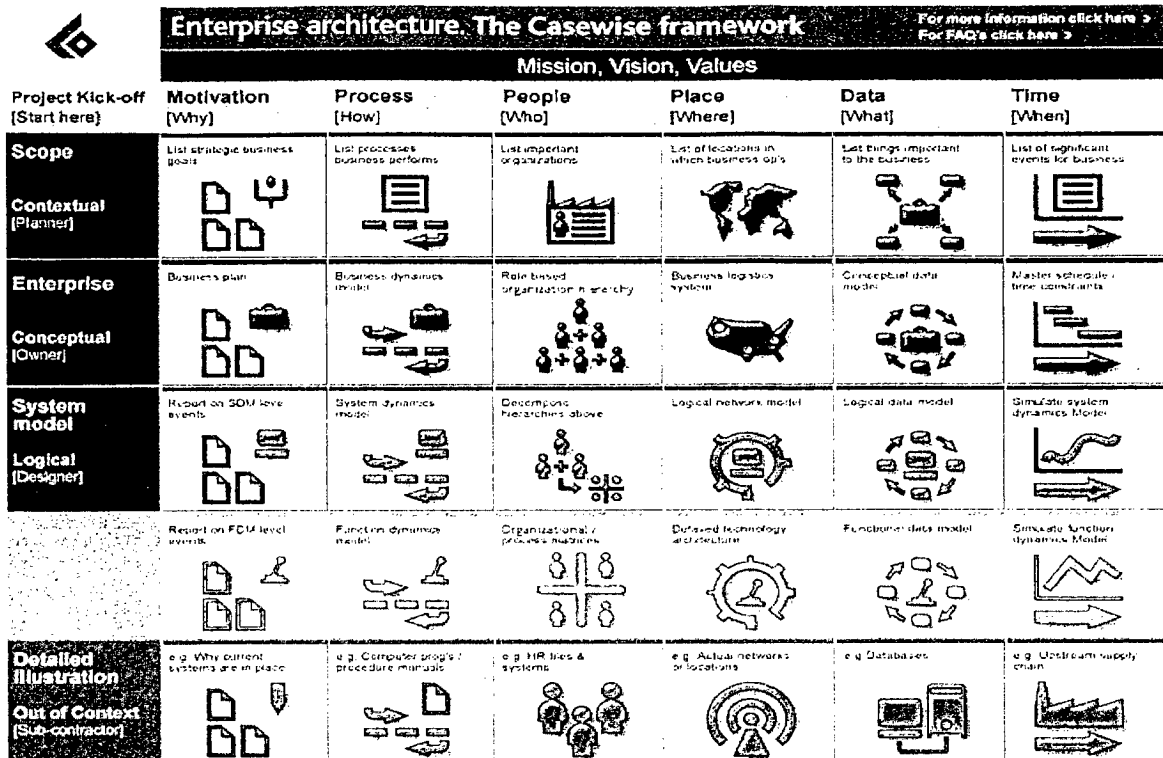

Figure 3-7: Enterprise Architecture View Framework Implementation (Casewise) [47]

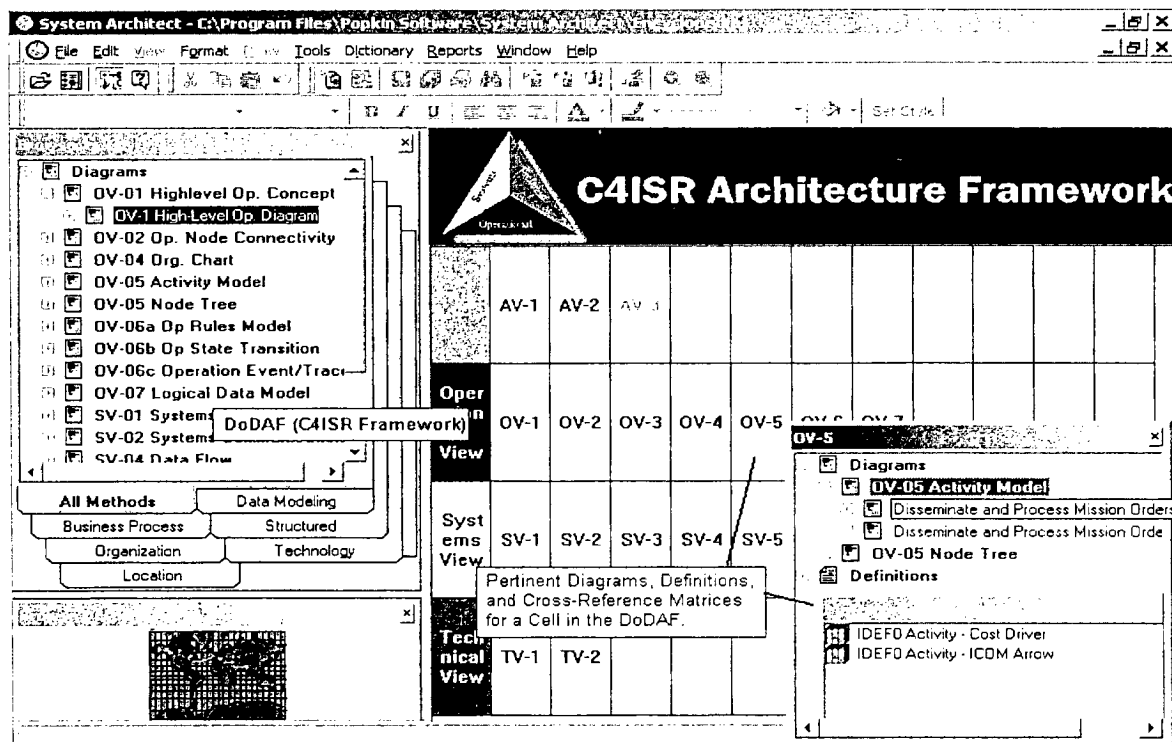

Figure 3-8: C4ISR Modeling Framework Implementation (Popkin) [48]

Figure 3-9 shows how the modeling and analysis tools provided by the BPA vendors can collaborate together through the mean of a central data repository to allow the development and the sharing of multidimensional business objects to its participants. This approach implements, to some extent, the concept of DPD introduced in Section 2.

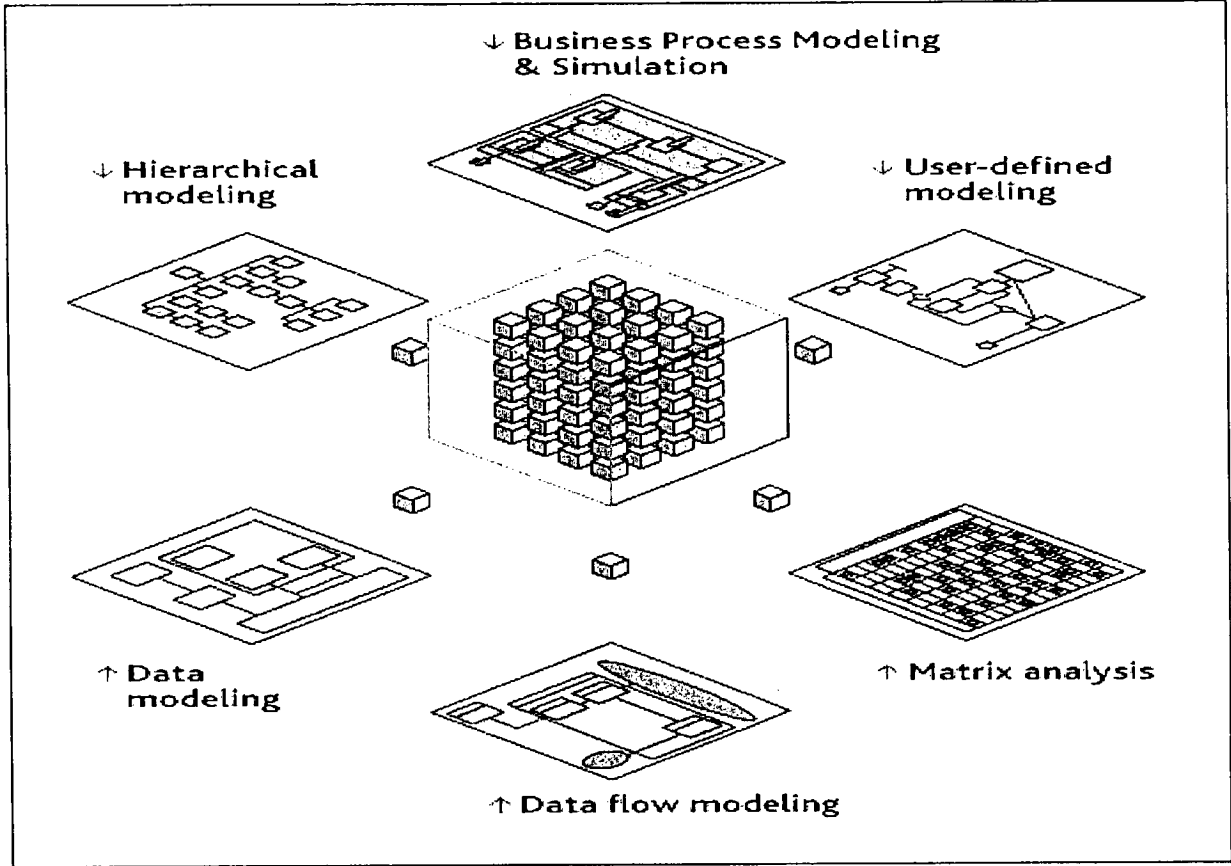

Figure 3-9: Central Repository Promoting Object Sharing (Casewise) [49]

Once the business processes have been modeled, various simulation tools can be used to monitor the effect of change on elements such as throughput times, resource utilization or costs. As shown in Figure 3-10, simulations can take different forms, including animated workflows, graphical and tabular data presentations.

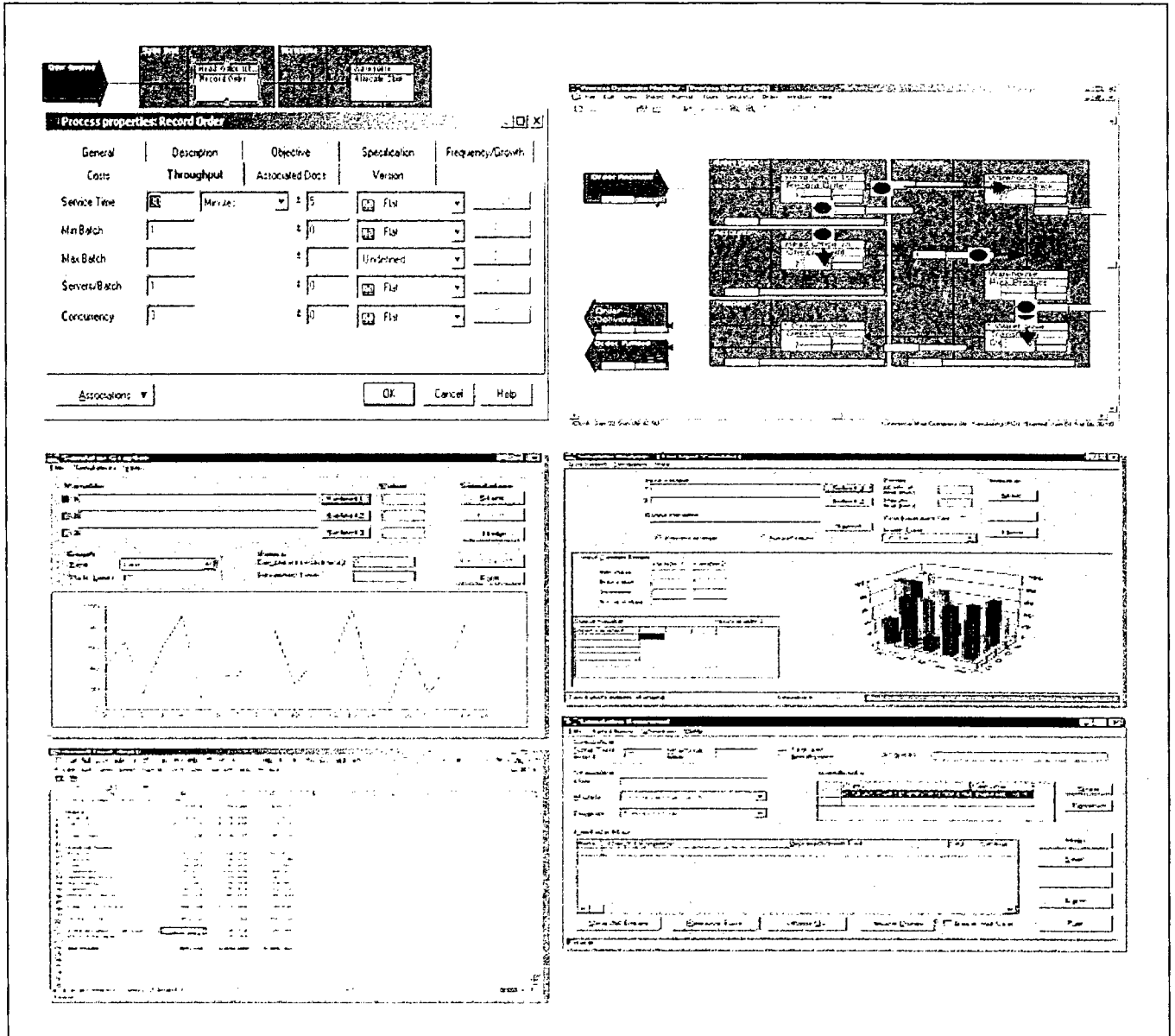

Figure 3-10: Simulation and Analysis Tools (Casewise) [50]

Annexe B presents candidate modeling tools categories to support the CEP along with some product examples.

3.4.2 Simulation tools

Within the different CEP activities, simulation tools can be used to 'animate' various models that have been created to see how the system will perform. The results of the modeling activities produce static models that represent various elements of the system from information flow depictions to detailed physics based system models. By using simulation, you can bring these models 'to life' and see how they perform over time by themselves as well as within a larger system.

As with modeling, weaknesses and shortfalls can be identified from the simulations developed. Simulation can be used to further refine requirements of the system to obtain greater functionalities and/or efficiencies.

The tools described in this section are primarily from a military viewpoint. Although this is beneficial for the intended application, it is also important to understand what simulation activities are being conducted in other domains. One area of significant growth in recent years is business simulation. Most BPA vendors provide simulation tools to help analyze business processes behaviour once they have been modeled. These tools help identify process bottlenecks, evaluate process scenarios, reduce throughput times, perform capacity planning and optimize resource usage and costs. These constructive simulations are generally developed using a combination of discrete or random events simulators supported by the CASE tools. As for the BPA modeling tools, further analysis of the BPA simulation tools would help better estimate their benefits and potential shortfalls in the context of the CEP.

Many Simulation Companies are now focusing on Suites of tools that are wrapped into much larger toolsets. This allows users more flexibility to put together 'just what is required' for their particular simulation.

One example of a packaged toolset is OneSAF. The toolset includes an entire range of components integrated into a seamless architecture that allows interoperability between each component. Figure 3-11 depicts the architecture. It demonstrates that a common toolset can be used across many domains by many different stakeholders in many different mission areas. The top of the figure depicts typical mission areas where the OneSAF product is employed. Each of the layers below this line group the individual tools by functional area and intuitively describe the hierarchy of simulations from source databases at the bottom to management and analysis tools at the Product Layer.

Product Line Architecture Framework (PLAF) Static View (v18)

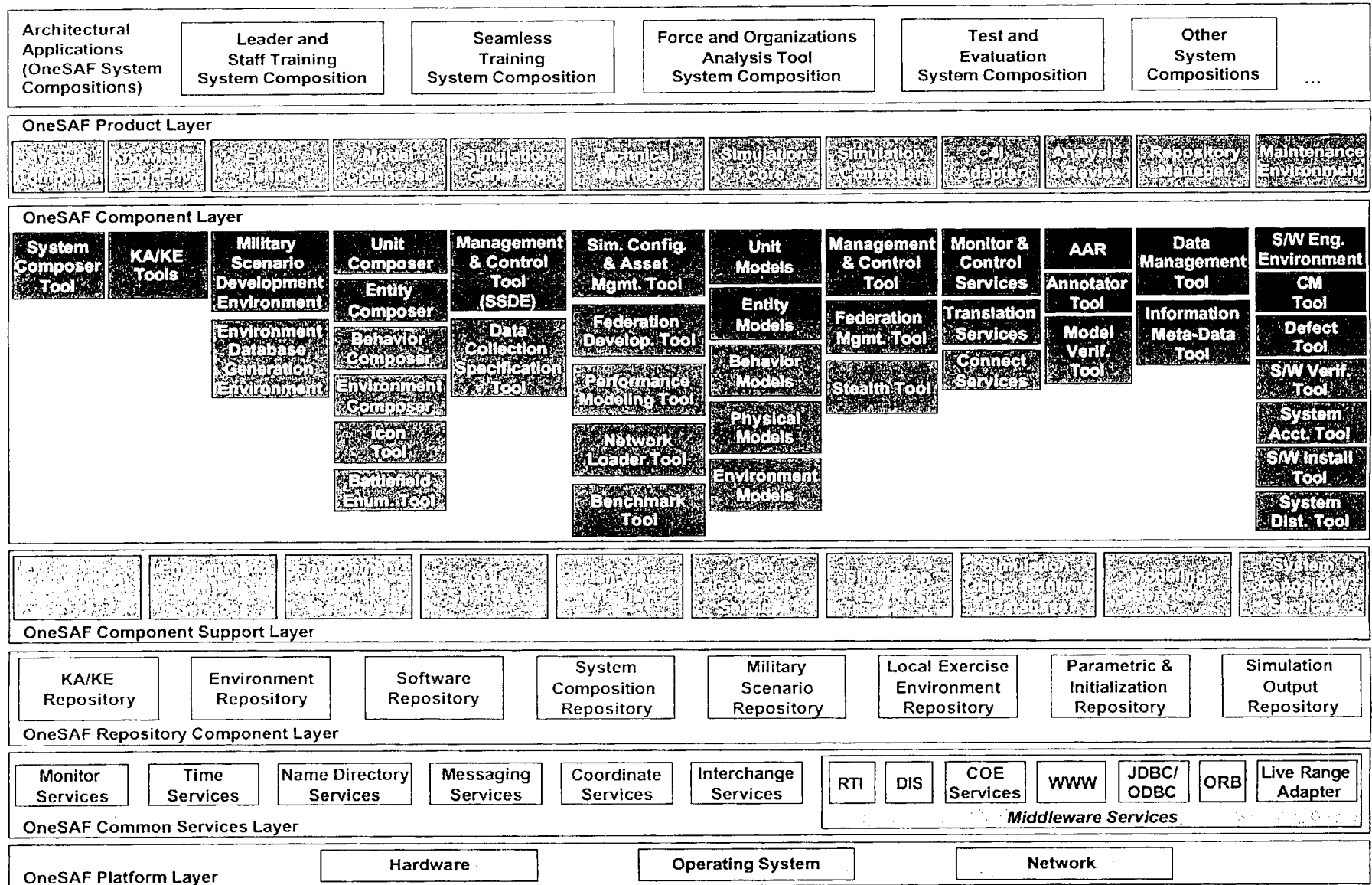

[Enter report no.]

Figure 3-11: OneSAF Product Line Architecture [52] 37

Another common trend within the simulation industry is a focus on interoperability. This is especially true for SBA where models and simulations must be used for different purposes at each phase of the acquisition process. Along with interoperability comes collaboration. Since so many project teams are geographically and culturally dispersed, it is essential to provide robust collaborative capabilities into any M&S effort. Modeling and Simulation Resource Repositories (MSRR) are becoming essential along with standards for building and describing the contents contained within them.

The following screenshots in Figure 3-12, Figure 3-13 and Figure 3-14 are taken from the Joint Simulation Based Acquisition Task Force Roadmap for SBA [53] and demonstrate some of the current trends that will enable a truly robust M&S Tools capability for the CEP.

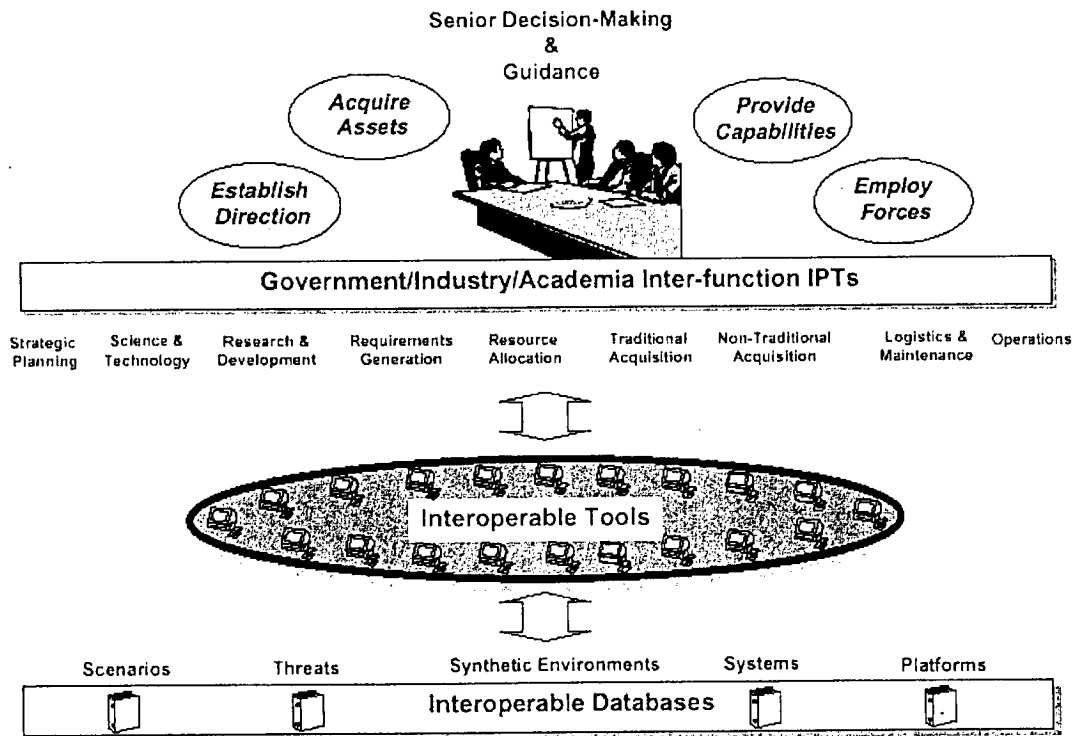

Figure 3-12: To-Be Collaborative Environment [53]

Figure 3-12 demonstrates an architecture whereby all stakeholders have access to the information they require for their area of interest within the project. As well, as information is updated by each stakeholder in the project, that data is now shared by all. Each functional area of the acquisition process (i.e. Research & Development, Resource Allocation, etc.) requires a different viewpoint on the M&S environment. By using interoperable tools, the source databases can be shared by each functional area while still providing the required access/viewpoint. This alleviates the 'stove piping' that is so common in today's acquisition process.

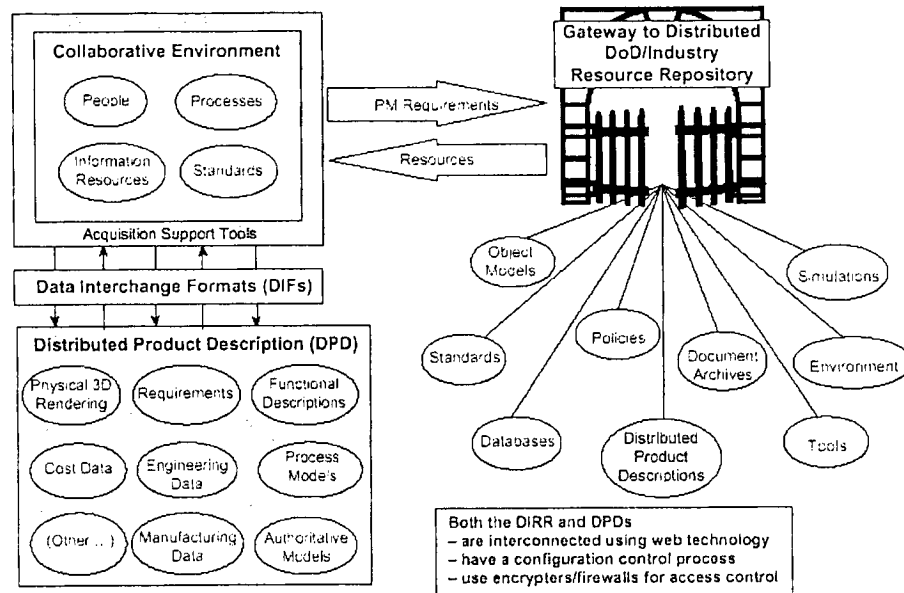

Figure 3-13: Top Level view of SBA Systems Architecture [53]

Figure 3-13 extends the concept of collaboration to the enterprise level. It shows how the interoperable databases of Figure 3-12 are placed into a M&S Resource Repository where all projects can benefit. The MSRR is also extended to include standards, policies, tools, etc. Now the collaborative environment where the project team works has easy access to a much broader resource base and can also 'post' the latest variants of the Distributed Product Descriptions where other IPTs can use the data. The DPD provides a framework for describing a system without restricting the underlying toolset. This of course results in many possible data formats of the source. The Data Interchange Formats provide the layer of interpretation/translation for the Acquisition Support Tools resulting in a very flexible yet powerful capability.

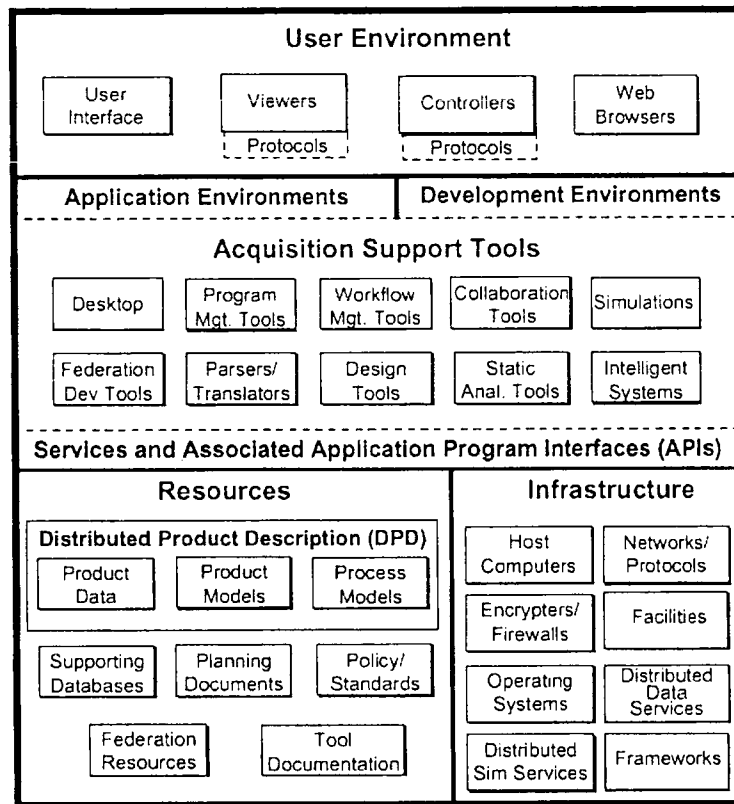

Figure 3-14: Collaborative Environment Reference Systems Architecture [53]

Figure 3-14 describes an architecture within the collaborative environment. For any tool to work, it requires infrastructure to operate on (computers, networks, etc.) and data/resources (models, databases, etc.) to draw from or interact with. By using Services and Application Program Interfaces, the resources can now be accessed by any of the Support Tools alleviating the constraints of typical standalone or proprietary systems. This interoperability is essential to a robust collaborative environment. The resulting environment also requires a means for user interaction both for passive viewing and active control. By following the same methodology as the previous layer and using common standards and protocols, a robust User Environment can be created that does not constrain the end users and provides the necessary user interfaces for effective control within the architecture.

Annexe C presents candidate simulation tools for the CEP.

4. M&S AND CEP

The previous sections have briefly introduced the CEP as defined so far by CapDEM-TDP. M&S background, fundamentals, and tools have also been provided in order to better understand the role of M&S throughout the various acquisition phases and activities. As previously explained when defining the M&S hierarchy and M&S functional areas, M&S can be exploited in many ways when it comes to developing and delivering a new capability.

This section focuses on the role of M&S in supporting the preliminary definition of the CEP available at the writing of this report time. As stated in Section 2, a potential scope for the CEP would involve it from the IDentification phase of the acquisition process up to early in the Implementation phase (as depicted by Figure 2-1).

With this potential scope some potential tasks to be accomplished can be hypothesized:

- 1) Establish the Current Situation
- 2) Develop a Capability Vision
- 3) Develop an Architecture
- 4) Establish the Transformation Roadmap

4.1 Establish the Current Situation

4.1.1 Focus

Within the scope of the operational capability deficiency identified, this phase aims at presenting the current Business Architecture and the inherent "capabilities" it provides. As mentioned by Schmidt [11], *"this Architecture is described in terms of Organizational Structure, roles & responsibilities and business processes. The Architecture is documented in an Operational Model, describing the business processes, and a Physical Model describing the facilities/platforms, systems, interfaces and operators."*

This phase is accomplished with the help of the following information:

- Capability Context and Boundary
- Operational Requirements Baseline
- Capability Objectives

The following outputs should be obtained at the end of the process phase:

- "as-is" Integrated Architecture Models (Operational, Functional and Physical)
- Key Performance Measures (Capability Metrics - MOE, MOP, etc.)

- Requirements Fit
- "as-is" Integrated Architecture's Inherent Capability (Capability Analysis)
- Costs and Risks

4.1.2 Activities

Operational Model

The Operational model addresses how the military command structure organizationally conducts military operations according to policy, doctrine, and tactics. *“The Operational model captures the “business processes” conducted by each organization as they pertain to a specific mission in terms of the operational activities and the exchange of information among the participating organizations”* [11].

Functional Model

The Functional model provides a functional decomposition of the activities and tasks carried out by the organization and its participants. *“The Functional model needs to be decomposed to a level where the functions or tasks are recognizable and can be allocated/assigned to a system or human operator, and the specific information (inputs & outputs), resources and timing/performance requirements can be allocated to each function or task”* [11].

Physical Model

The Physical model helps depict the physical configuration in terms of Platforms/facility, systems, system interfaces, and operational personnel. It also provides human machine interfaces.

Identify Measures of Effectiveness

The MOE define how the architecture is to be evaluated in terms of performance, efficiency, effectiveness, and resource utilization.

Identify Areas of Opportunity for Improvement

The previous activities provide the necessary information for evaluating the “as-is” Architecture and determining where opportunities for improvement exist. Potential alternatives of solution to improve the Architecture can be evaluated. *“The Systems Engineering Process establishes a generic approach for conducting trade-studies, assessing the risks and evaluating the cost/benefits associated with each alternative”* [11].

4.1.3 Role of M&S

Organizational Structure

The organizational structure helps provide conceptual representation of an organization by graphically presenting how it is structured in terms of people, roles, functions, or services, and how these organizational elements share responsibilities, dependencies and relationships among them.

M&S only plays a role for organizational structure with respect to modeling. You can model the organization but since there is no time component it is impossible to simulate, therefore we will only discuss it in terms of modeling. In the latter stages, we will be able to look at how information flows through an organization using simulation.

Modeling plays an important role in visualizing an organizational structure. Without the ability to visualize an organization, it is almost impossible to understand its complexities. For very simple organizational structures it would be possible to describe it in words or sentences but the relationships become very difficult to conceptualize.

There are many ways to model an organizational structure. Within the Military, organizations are typically represented by their command-and-control hierarchy. This command-and-control hierarchy works well for reporting lines and supervision but does not necessarily represent the operational organization as it conducts business in a day-to-day fashion. The organization can also be modeled with respect to the operations that it conducts. This structure would be based upon information flow or chronological sequence of events in conducting particular tasks. Often it is necessary to model the organizational structure using more than one method to fully understand it.

Figure 4-1 depicts a typical organization chart. It is based entirely on reporting lines and 'who works for who' and does not describe the day-to-day interaction of the various people within the organization. It also demonstrates how an org chart can create confusion such as the Vice Chief of Defence Staff position who appears to have two 'bosses'. It does not depict which responsibilities are to the DMND and which are to the CDS. This is where a command and control representation becomes more practical as they will represent a very structured representation of the organization based upon a particular activity.

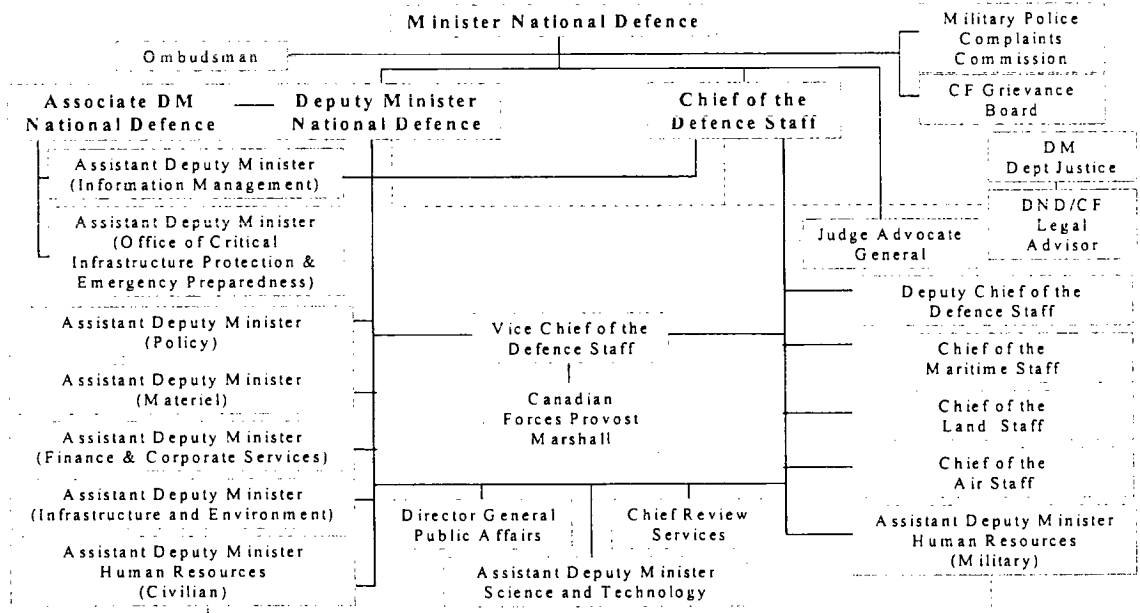

Figure 4-1: Example of Organizational Structure Model [18]

Figure 4-2 depicts a typical command a control organizational chart which is described here as an Operational Organizational Model. The key difference between this figure and Figure 4-1 is that this org chart is for only one function of the overall organization – deployed operations. This is the command and control relationship that will be used when a Tactical Helicopter Squadron deploys on a mission and is operating in the field such as Somalia. When the squadron is back at their base in Canada, they will have a different command and control organization chart.

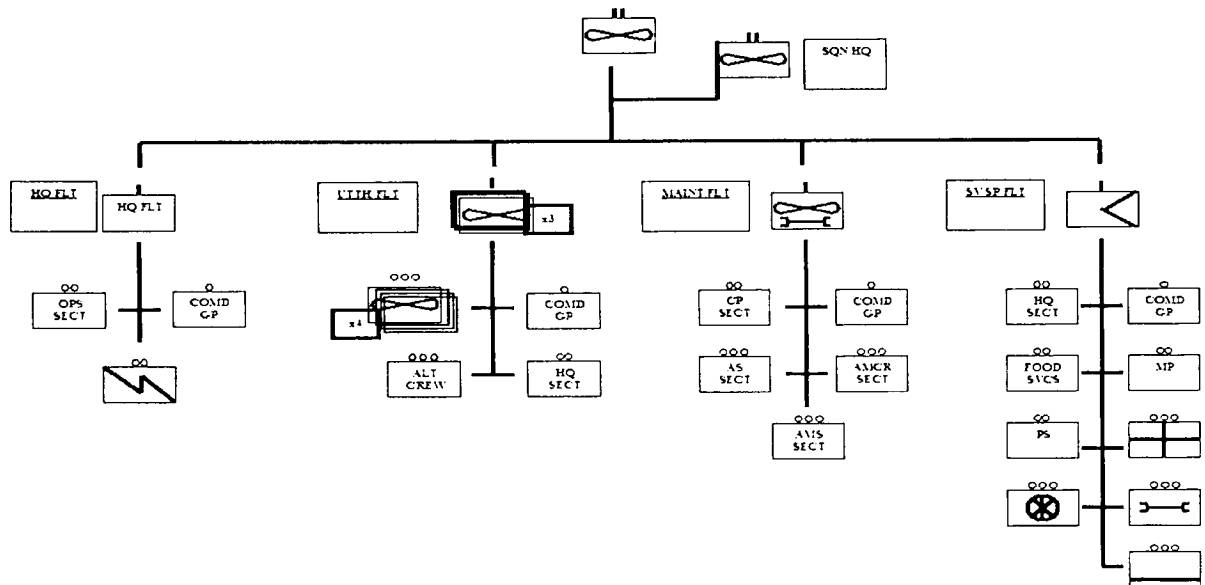

Figure 4-2: Example of an Operational Organizational Model [19]

Activities Performed by Each Element

By expanding the organizational structure model created in the first step to include the activities performed by each element, the analyst can now start to see how the organization works. It is important to have an organizational structure that represents the day-to-day business of the organization especially with respect to command-and-control.

Based upon the organizational structure defined in the first step, the analyst can then start to map out the activities performed by each element within the organization. There are many ways to model the activities performed by each element, including simple techniques such as flow charts or more complex techniques using modeling notations such as UML.

The modeling can be particularly effective if the activities are mapped directly against the organizational structure. By doing this, it is not only possible to see what the organization looks like, but also what the organization does.

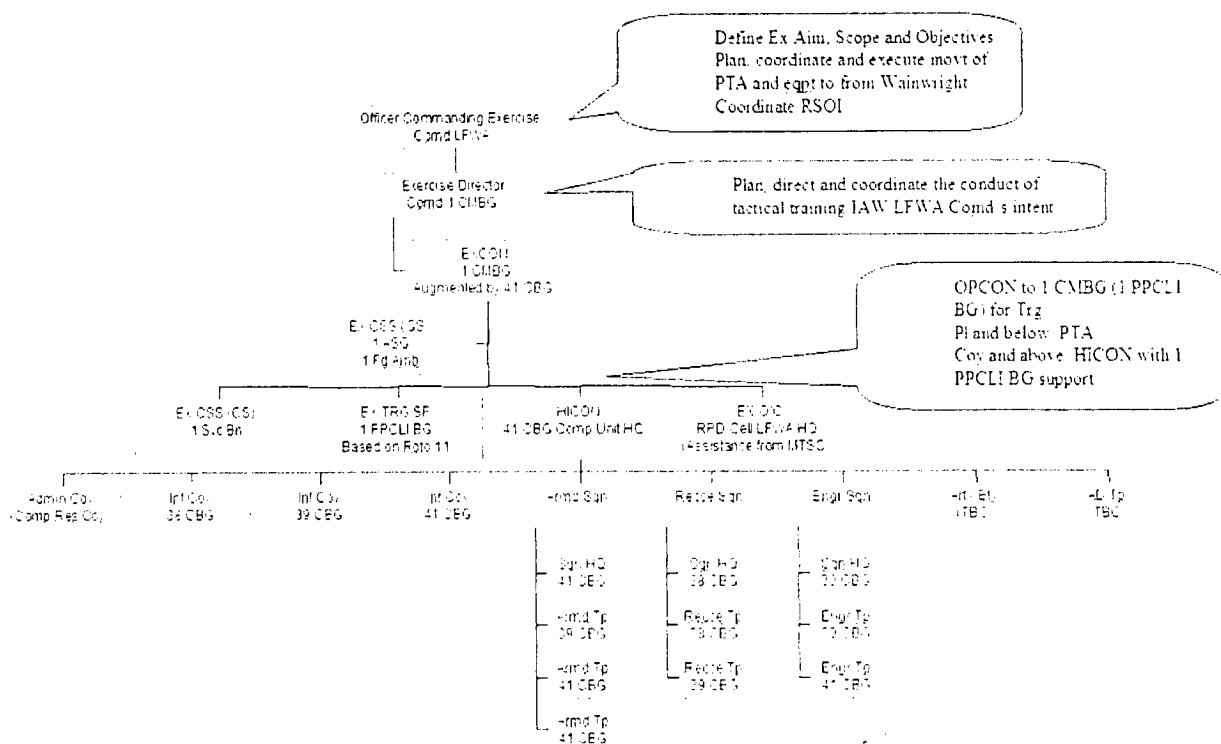

Figure 4-3: Example of Activities Performed by Each Element [20]

Information Exchanged Among the Participating Organizations

Another critical element in understanding how the 'as-is' integrated architecture works, is modeling the flow of information throughout the organization. Detailed modeling of the information exchanged among the participants quickly leads to understanding deficiencies in the system. The IDEF0 notation is a particularly effective way of showing the information exchanged among its participants. It allows a model to be created that has elements of the organizational structure combined with the activities performed and linkages showing the information exchanged¹³.

Figure 4-4 depicts how 1 Wing conducts Tactical Aviation Operations using the IDEF notation. The model starts with boxes for each separate activity that the organization performs (such as 'Develop Plans'). For each activity box, there are four sets of arrows. The arrows coming into each activity box from the left are Inputs. For example, in order to Develop Plans, the organization needs the latest Intelligence. The arrows out of the right side of the box are the Outputs of the activity. For example, one of the Outputs from Developing Plans is the 8 Week Forecast. These Outputs then become Inputs to some other part of the organization's activities. The arrows on the top of each box are the Controls that constrain or direct the activity. For example, the Defence Planning Guidance manual is consulted while the Develop Plans activity is conducted. The arrows coming in from the bottom are the Mechanisms that allow the activity to proceed. For example, the Telephone is used by the personnel who are Developing Plans to get the Intelligence.

¹³ Data Flow Diagram (DFD), Extended Functional Flow Block Diagram (EFFBD), and UML 2.0 are other examples of information flow modeling approach.

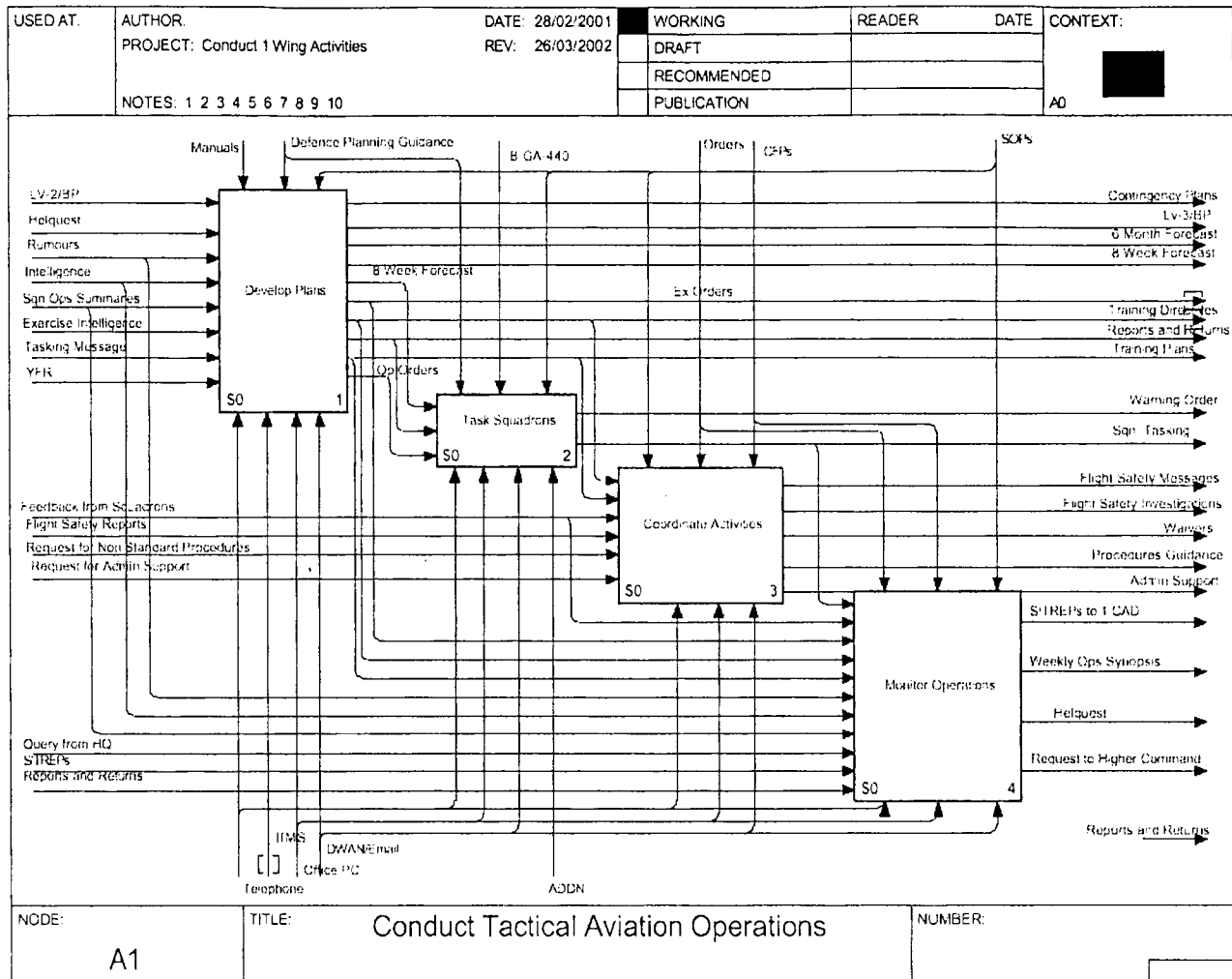

Figure 4-4: IDEF 0 Model showing information flow [21]

Although the IDEF modelling technique is very effective in demonstrating how information flows throughout an organization and what activities are conducted at each step, it does not explain the content of the information or how the information is processed. One robust method for fully understanding the complexities of information flow throughout an organization is to conduct an Information Flow and Processing (IFP) analysis. For each lowest level activity, detailed information is provided to fully understand what is going on.

Figure 4-5 shows a typical IFP Analysis database record. In this case, the activity (or Goal of the individual) is to Conduct Element Split Attacks. This is one of the activities that an F-18 pilot performs in the conduct of a mission. The IFP provides a description of the activity along with very detailed information on how information flows throughout the activity and how the information is processed. It includes information requirements, information sources, decisions, accuracy/precision, physical actions, feedback and influencing factors.

IP Number	7.2.2.1(f)	Source Task	7.2.2.1(f)
Goal		IFP Data Entry Form	
Conduct Element Split Attacks			
Description			
While flying in tactical formation, at the pre-planned range from the target, wingmen perform an energy sustaining 90 degrees turn into lead. Roll out on perpendicular track and maintain heading for the required time (5-20sec). At the appropriate time or on a visual ground reference, wingmen turn back towards the target and conduct their own attack, having achieved the required time separation from their leads. Wingmen then cross check that they have the required separation as lead is over flying the target and adjust the run-in accordingly.			
Information required to achieve goal		Source(s) of information required to achieve goal	
Aircraft operating procedures: Tactics Standard Operating procedures.		HUD: Aircraft position, heading, altitude, speed, g, timing, distance from other aircraft	
Mission requirements and objectives: Specifics of the tactical situation (e.g. threat/friendly forces, weather, terrain, etc.). Details of on-going or planned activities. Type of weapons delivered.		Visually: Aircraft position, heading, altitude, speed, navigation visual references. Own aircraft position in the formation and other members position, distance from other aircraft	
Aircraft position, heading, altitude, speed, g		Seat of the pants: aircraft g	
Timing, navigation visual references		Link 16/MIDS display: Aircraft position, Own aircraft position in the formation and other members position, distance from other aircraft	
Own aircraft position in the formation and other members position, distance from other aircraft		RDR display: Aircraft position, heading, Own aircraft position in the formation and other members position, distance from other aircraft	
Decision(s) required to achieve goal		Type of reasoning required to achieve goal	
Decide that aircraft has reached desired range/timing		Rule	
Decide to start execution of the manoeuvre		Level of precision/accuracy required for the above type of reasoning.	
Decide to roll out on desired heading to get spacing		High	
Decide that proper delay timing has been achieved		The start of the manoeuvre does not have to be as precise as the execution of it. The start is effective within 2 nm or 15sec.	
Decide to turn back towards target		The execution has to be precise. Turn to heading +/- 5 deg, timing delay +/- 2 sec, airspeed within 20 kts	
Decide to verify spacing from lead		The pilot has to analyse all inputs precisely to ensure that the desired separation is achieved. The pilot will want to achieve the desired separation	
Decide to adjust spacing if required		Level of precision/accuracy required for the aforementioned physical action(s).	
Physical action(s) required to achieve goal		Medium	
Look at displays		Proper separation will be achieved by a relatively precise and accurate execution of the physical actions required. The level of precision does not have to be as high as the reasoning (or results). The precision in the results will be achieved by a series of less precise physical inputs to the controls.	
Look out		Higher precision required in the visual analysis of the distance from lead, 2 sec required every time the distance is assessed.	
Move stick laterally to roll aircraft (repeated)		Factors that influence the achievement of goals	
Pull back on stick for desired amount of g (repeated)		Position in the formation	
Roll out by moving stick (repeated)		Terrain	
Move throttles to maintain/sustain energy		Navigation features	
Type of feedback required to know that goal has been achieved		Required separation (type of weapon)	
Visually, Auditory, Cognitive		Threats	
Source of feedback required to know that goal has been achieved		Workload	
HUD		Type of target (easy vs hard)	
Link 16/MIDS		Eyesight / ability to maintain visual contact	
AMIRS		Other formation members relative altitude in the run in	
RDR		Situational Awareness	
Visually		Level of precision achieved by other formation members (routing/airspeed)	
Tone from radio		Accuracy of INS/GPS platform	
		Amount of g pulled in turns	
		Tactical situation	

Figure 4-5: Information Flow Detailed Data Entry [22]

The resulting detailed data with respect to information flow can be kept within a database that can be 'linked' to objects within the organization/activity model (IDEF).

It is also possible at this step to conduct simulation. Typically constructive simulation tools are used at this phase, where the analyst can run the model over time and see how the information flows throughout organization. Typically metrics are provided for each of the activities such as task completion time, probability of error and others. The information is also

represented as an aggregate within these models, where all the details and subtleties are left out.

Figure 4-6 is a Task Network Model depicting an F-18 Pilot reacting to an airborne threat. Each oval within the diagram is an activity with an associated task completion time and a set of algorithms that represent the information flow and processing. There are multiple branches represented in this Task Network as there are many possible ways to React to Threats. Some branches are multiple branches where the pilot may have to conduct two activities at one time (such as fly the aircraft and deploy a weapon). These task network models can then be executed (simulation) many times in order to capture metrics on how well the information flows throughout the system and how well the human can function within this system. This results in effective data on mission performance and effectiveness of systems.

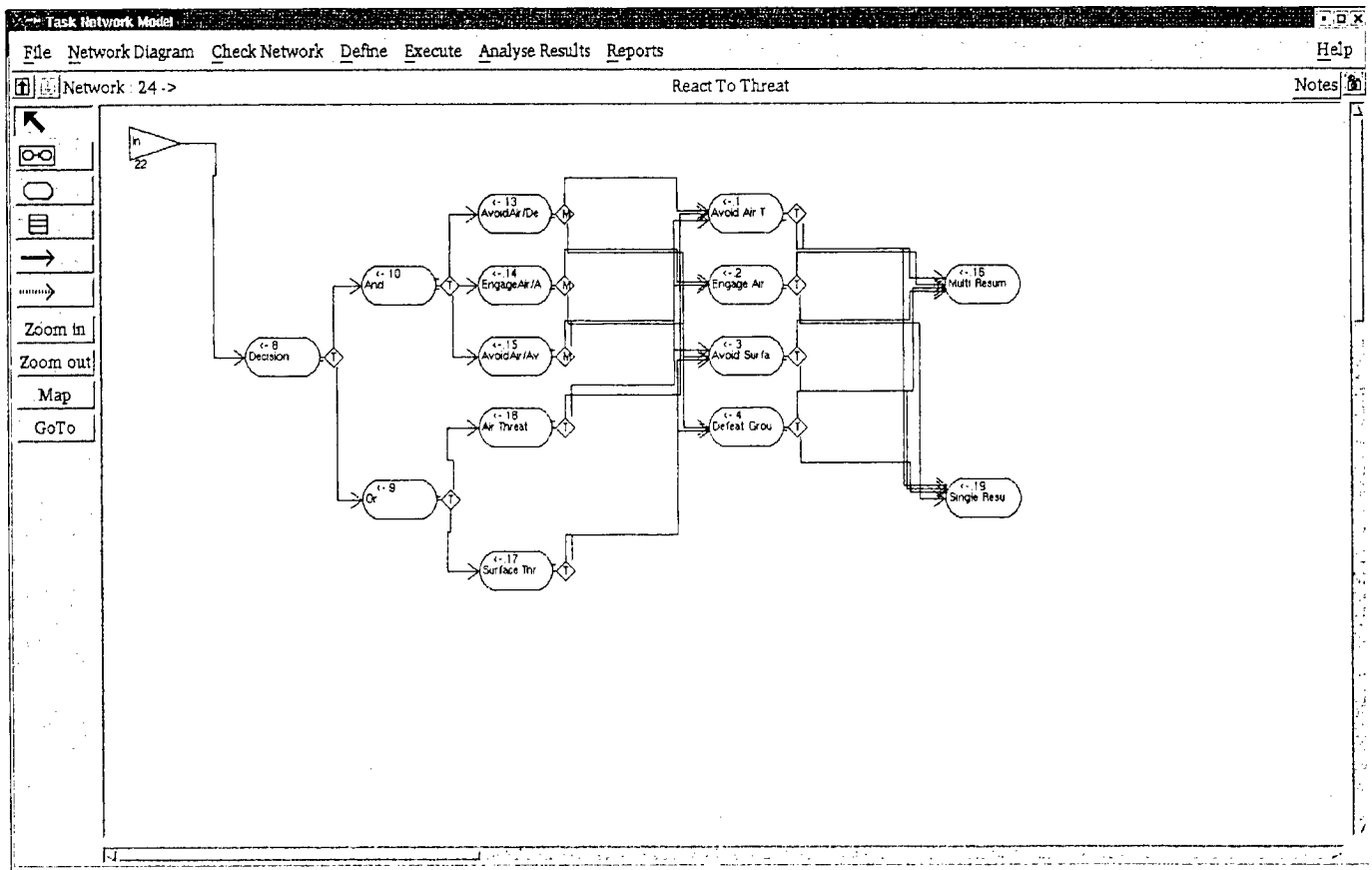

Figure 4-6: Task Network Model Simulation [23]

Resources Required

The activities described to this point have been independent of the resources required to perform the functions and tasks within the organizational structure. Since resource requirements are such a critical element of new acquisitions, it is important to fully understand how the 'as-is' system is staffed. Within the field of M&S, these typically fall into the domain of manning studies. It is a relatively simple task to put in manning levels within the model of the organizational structure, even if it is just a spreadsheet. This will allow the analyst to tally up the totals for any particular functional area or within the organization as a whole. By integrating Manning into the simulations, it is now possible to look at workload not only by individual, but by functional areas within the model as well. This allows the analyst to see what the current utilization of the staff within the organization look like and possibly identify bottlenecks in the flow of information, or the reliability of the information passage.

Crewmembers and Automation - Task Assignment

Current Mission: ALSC

Function/Task	Captain	Navigator	XO	START
Prepare Voyage/START				Primary
Prepare Voyage/Gather Ship Related	Primary		Contingency	
Prepare Voyage/Select Route	Primary		Contingency	
Prepare Voyage/Gather Navigation In	Primary		Contingency	
Prepare Voyage/Determine Plan Phas	Primary		Contingency	
Prepare Voyage/Determine Route Set	Primary		Contingency	
Prepare Voyage/Select Means and M	Primary		Contingency	
Prepare Voyage/Assign Watch-stande	Primary		Contingency	
Conduct the Passage/START				Primary
Conduct the Passage/Observe Air ant		Contingency	Primary	
Conduct the Passage/Observe Fairwa	Primary	Contingency		
Conduct the Passage/Monitor Headin	Contingency	Primary		
				Primary
				Contingency

OK
Cancel
Help

Figure 4-7: Resource Allocation using WinCrew™ [24]

Figure 4-7 depicts a typical Task Assignment table for a manning study. It is used to assign who conducts each task within a Task Network Model such as that shown in Figure 4-6. Once all the people have been assigned to each task, the model can be executed to see how well the system performs using the particular manning assignment. In Figure 4-7 the personnel on the ship are represented in the right hand columns while the tasks to be performed are in the left column. The analysts can try different variants and options to see which ones work best. The analysts will be able to see individual workload by

each member of the crew over multiple simulations to see where certain individuals are overworked or underutilized.

Functional Decomposition

To really understand the 'as-is' integrated architecture, it is necessary to drill down into the individual sub functions of an organization. By taking the high-level functional model defined earlier in the process, each function can be subsequently subdivided into sub functions. This process can be repeated again and again until unique, discrete tasks are identified. The typical method of modeling a functional decomposition is by using a relational database, which would depict the hierarchy of the decomposition.

Figure 4-8 demonstrates a Functional Decomposition for an F-18 pilot on a tactical mission. One of the possible missions that the pilot can be asked to carry out is to Conduct an Anti-Surface Mission (a top level function - 7). Many functions must be performed to complete this particular mission, one of which is to Conduct Air Interdiction (first level function - 7.2). Air Interdiction can be subdivided into its functions one of which is Conduct Target Attack (second level function - 7.2.2). There are many different ways to conduct a Target Attack, one of which is to Conduct a Precision Guided Munitions (PGM) Attack (third level function 7.2.2.2). The PGM Attack is then subdivided into all of the individual tasks that are performed by the system (man and machine) to complete the attack (fourth level functions or tasks - 7.2.2.2(a-o)).

TopLevNum	TopLevFunc	Lookup to Project	s_Collineage	s_Generation	s_GUID	s_Lineage
7	Conduct Anti-Surface Mission	CF18 Air to Ground	.ong binary data		1 30BAE3CFDD6}	.ong binary data
	FirstLevNum	FirstLevFunc	s_Collineage	s_Generation	s_GUID	s_Lineage
+ 7.1	Conduct Tactical Rendezvous		.ong binary data	1 004BE0FF3562}	.ong binary data	
- 7.2	Conduct Air Interdiction		.ong binary data	1 7CAD406A0E1}	.ong binary data	
	SecondLevNum	SecondLevFunc	s_Collineage	s_Generation	s_GUID	s_Lineage
+ 7.2.1	Conduct Ingress		.ong binary data	1 3DD3421F4F72}	.ong binary data	
- 7.2.2	Conduct Target Attack		.ong binary data	1 551B30EE0A7}	.ong binary data	
	ThirdLevNum	ThirdLevFunc	s_Collineage	s_Generation	s_GUID	s_Lineage
+ 7.2.2.1	Conduct General Purpose (GP) Bomb Attack		.ong binary data	1 3F461475DFC6}	.ong binary data	
- 7.2.2.2	Conduct Precision Guided Munitions (PGM) Attack		.ong binary data	1 1589FFC8470}	.ong binary data	
	Task ID	Task Label				
7.2.2.2(a)	Conduct A/G Check					
7.2.2.2(b)	Designate Target Position	First NAV designate the Target position (or Offset aim	Completed			
7.2.2.2(c)	Identify Target Area with Aircraft Sensors	Anticipate what the target surrounding area look like b	Completed			
7.2.2.2(d)	Manoeuvre to Weapons Delivery Parameters					
7.2.2.2(e)	Identify Target Using Map/Imagery/Onboard Sensors/LINK 16	Anticipate what the target looks like by reviewing the t	Completed			
7.2.2.2(f)	Validate Weapons Solution Display					
7.2.2.2(g)	Deliver PGM (LGB/MAV/Adv PGM)	Depress and hold the weapons release button (Pickle	Completed			
7.2.2.2(h)	Conduct Self-Lasing LGB Delivery	Once PGM weapon is released, ensure that the Laser	Completed			
7.2.2.2(i)	Conduct Buddy-Lasing LGB Delivery	At the appropriate call from aircraft dropping LGB, mal	Completed			
7.2.2.2(j)	Update Target Designation	Adjust and update target designation on the desired a	Completed			
7.2.2.2(k)	Conduct Safe Escape Manoeuvre					
7.2.2.2(l)	Conduct BDA					
7.2.2.2(m)	Conduct Coordinated Attacks with Other Aircraft/Elements/Sec					
7.2.2.2(n)	Monitor Target Area Tactical Picture on LINK 16/MIDS Displays					
7.2.2.2(o)	Conduct Frag Avoidance Manoeuvre					
*						Not Started
+ 7.2.3	Conduct Egress		.ong binary data	1 58B5E00CB44}	.ong binary data	
+ 7.2.4	Initiate Recovery/Transit to Follow on Tasking		.ong binary data	1 481724266768}	.ong binary data	
+ 7.2.5	Establish and Maintain Tactical Formation		.ong binary data	1 14C91FE602BA}	.ong binary data	
+ 7.2.6	Conduct Enroute Navigation		.ong binary data	1 3FC0B7E73190}	.ong binary data	
+ 7.2.7	Conduct Sensors Search and Visual Look Out		.ong binary data	1 8E224DDF1D1}	.ong binary data	
*				(AutoNumber)	(AutoNumber)	
+ 7.3	Conduct OAS Close Air Support		.ong binary data	1 308E994900E6}	.ong binary data	
+ 7.4	Conduct Armed Reconnaissance		.ong binary data	1 3351EB635503}	.ong binary data	
+ 7.5	Conduct TASMO		.ong binary data	1 3CBB2C717BF}	.ong binary data	
+ 7.6	Conduct Air-to-Air Refueling		.ong binary data	1 18E361ACF0D}	.ong binary data	
+ 7.7	React to Threats		.ong binary data	1 7DA3DABCD4}	.ong binary data	
+ 7.8	Monitor Communications		.ong binary data	17 3A159255A185}	.ong binary data	
+ 7.9	Monitor Aircraft Systems		.ong binary data	17 30F8396DE014}	.ong binary data	
*				(AutoNumber)	(AutoNumber)	
*				(AutoNumber)	(AutoNumber)	

Figure 4-8: Function Decomposition Relational Database [25]

Function Allocation

Once these lowest level tasks are defined within the system, the analyst can then determine whether the function is conducted by a machine or by a human. This process is typically referred to as function allocation. Function allocations are typically done by the analyst directly within the database using predefined metrics or information from subject matter experts. The models that are formed as a result of this activity would purely show which functions are allocated to machines and which ones are allocated to humans. It is also important to note that although many task are done by machines, there is a human element in monitoring these machines, and these tasks must be accounted for as well.

Figure 4-9 shows the result of a typical Function Allocation where each lowest level function (task or Goal) has been assessed against 10 criteria

which indicate what machines are good at and what humans are good at. The result is a weighted sum that tells the analyst whether a task is better performed by a human or a machine. Figure 4-9 shows a list of tasks that have been allocated to a machine such as Monitor and Manage Mission Computer System. A machine can provide second to second monitoring and only alert the human when there is a problem. The task has then been allocated to the human to reflect the human role in monitoring the machine function.

Goal ID	Goal Label	Weighted Sum	Allocatio	Qualitativ Allocatio	Rationale
7.5.2.2(d)	Initiate and Monitor EID of Unknowns	-0.217	Machine	Human	Re-Allocated by Analyst to reflect Human Role in monitoring the machine function.
7.9.9.1(a)	Monitor and Manage Mission Computer System	-0.194	Machine	Human	Re-Allocated by Analyst to reflect Human Role in monitoring the machine function.
7.9.10.1(a)	Monitor and Manage EGI Equipment	-0.182	Machine	Human	Re-Allocated by Analyst to reflect Human Role in monitoring the machine function.
7.9.5.1(e)	Monitor and Manage Departure Warning Tone	-0.147	Machine	Human	Re-Allocated by Analyst to reflect Human Role in monitoring the machine function.
7.9.5.1(f)	Monitor and Manage Spin Recovery System	-0.137	Machine	Human	Re-Allocated by Analyst to reflect Human Role in monitoring the machine function.
7.9.11.1(f)	Monitor and Manage IFF Interrogator/Transponder (CIT)	-0.135	Machine	Human	Re-Allocated by Analyst to reflect Human Role in monitoring the machine function.

Figure 4-9: Function Allocation Example [26]

System Physical Model

The system physical model specifies the inner workings of a particular system. In a SoS example, it would describe each of the sub systems and how they relate to one another physically. There are many ways to create a system physical model. Another important aspect of the system physical model is the definition of the human machine interfaces.

Figure 4-11 demonstrates a System Physical Model of a Medium Altitude Endurance Unmanned Air Vehicle. The UAV interacts with many other physical entities such as Targets using on-board sensors, GPS satellites for navigation, command and control satellites for sending imagery back to the ground stations and for receiving control inputs from ground based UAV operators. This System Physical Model also depicts the various organizations and the type of information that will be passed by the various system components.

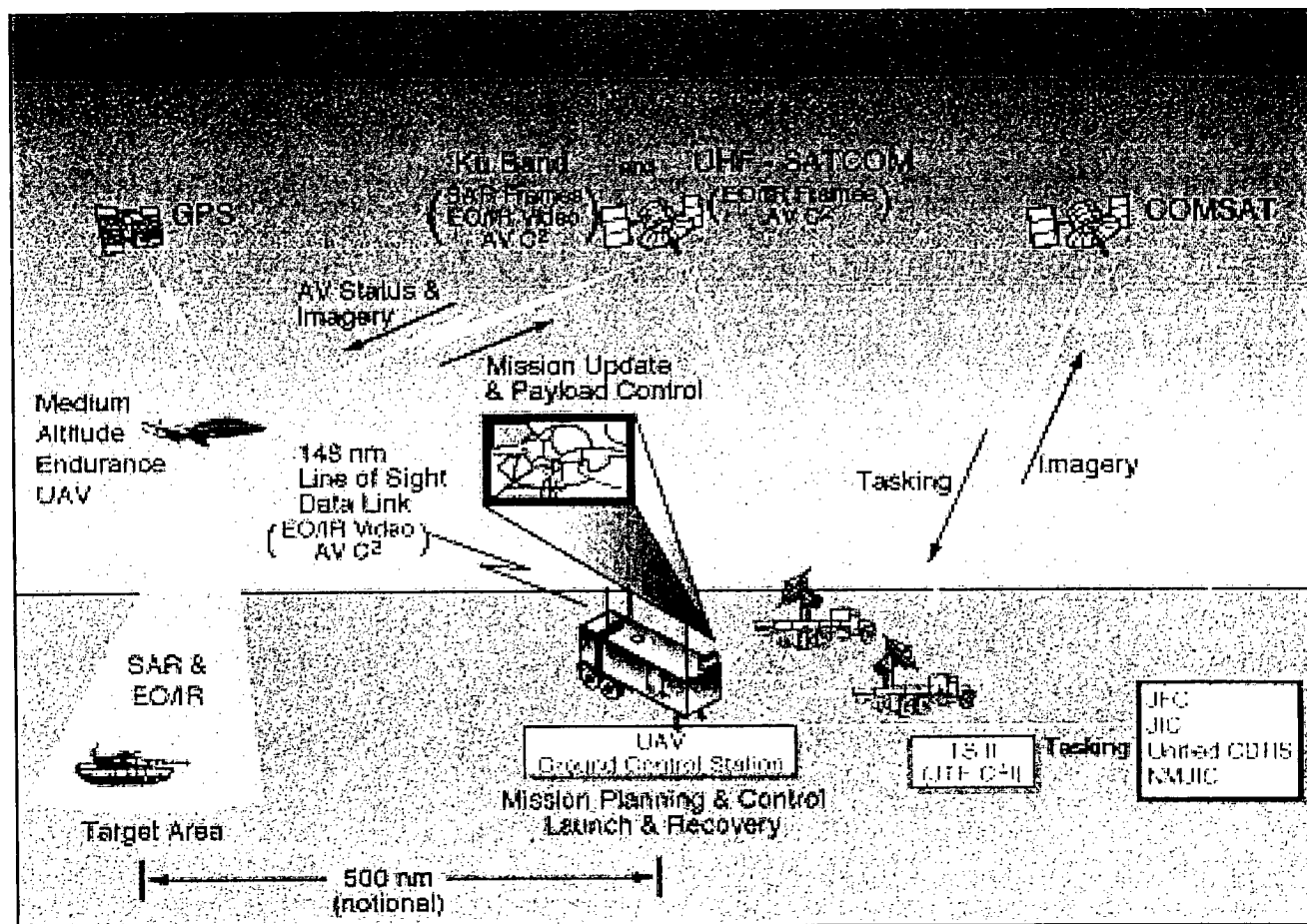

Figure 4-11: Example of a System Physical Model [28]

Figure 4-12 demonstrates a User Interface Physical Model. It allows users to assess the 'look and feel' of a system before it ever built.

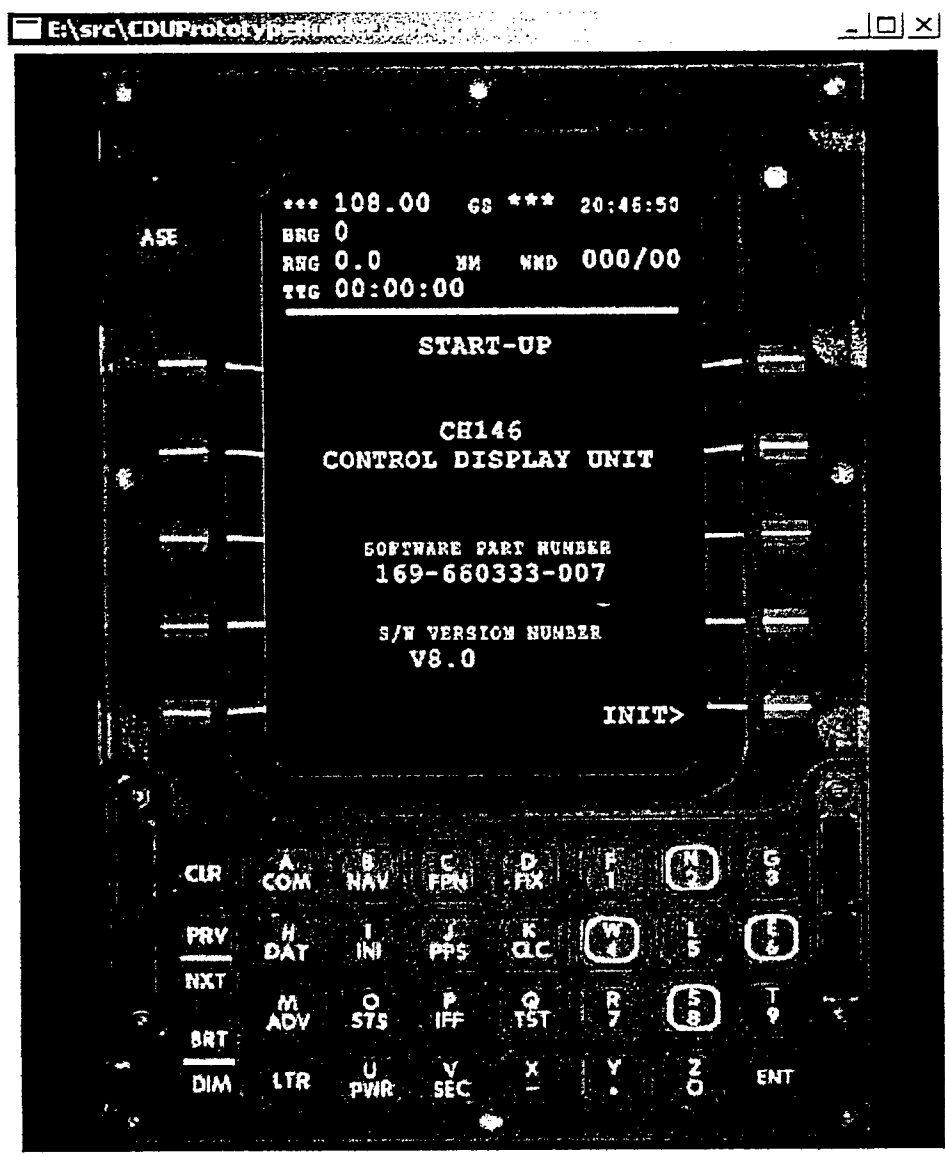

Figure 4-12: Example of User Interface Physical Model [29]

Operational Personnel & Manning

Once the physical model is complete, the analyst can then apply the operational personnel and manning to the model. It is also possible to conduct simulations that show the operational personnel utilizing the various interfaces and components of the system. Typically these are constructive simulations that are built using task completion times and system performance metrics.

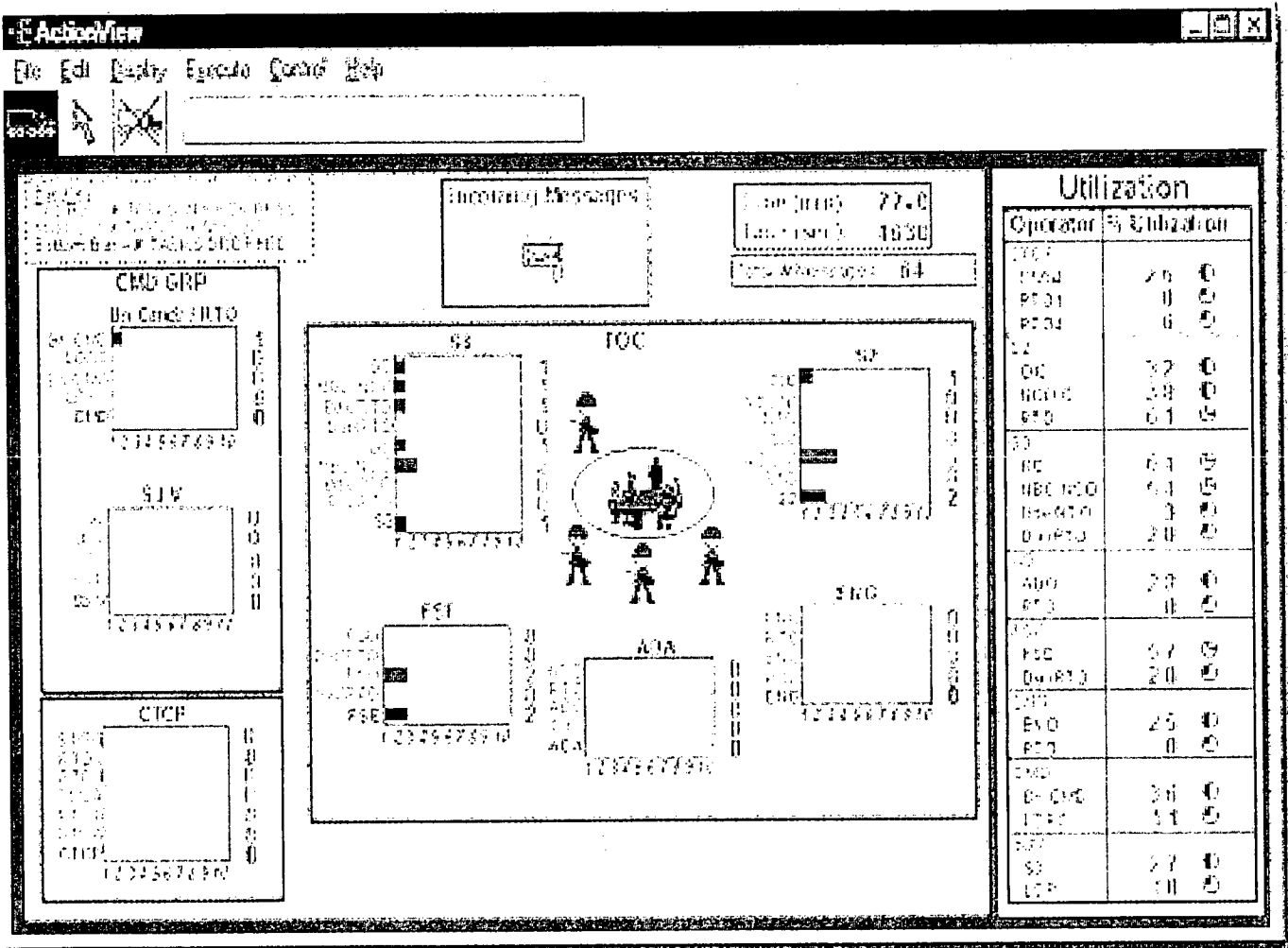

Figure 4-13: Example of Personnel in a Constructive Simulation (MicroSaint™) [30]

Figure 4-13 shows the Action View of a Tactical Operations Center simulation. Each of the tasks that must be performed is assigned to the personnel and then the model is executed many times. The analyst is then able to determine the utilization rates of each of the personnel as well as the effectiveness of the Tactical Operations Center. Different assignments can be made and simulated until an optimal manning solution is determined.

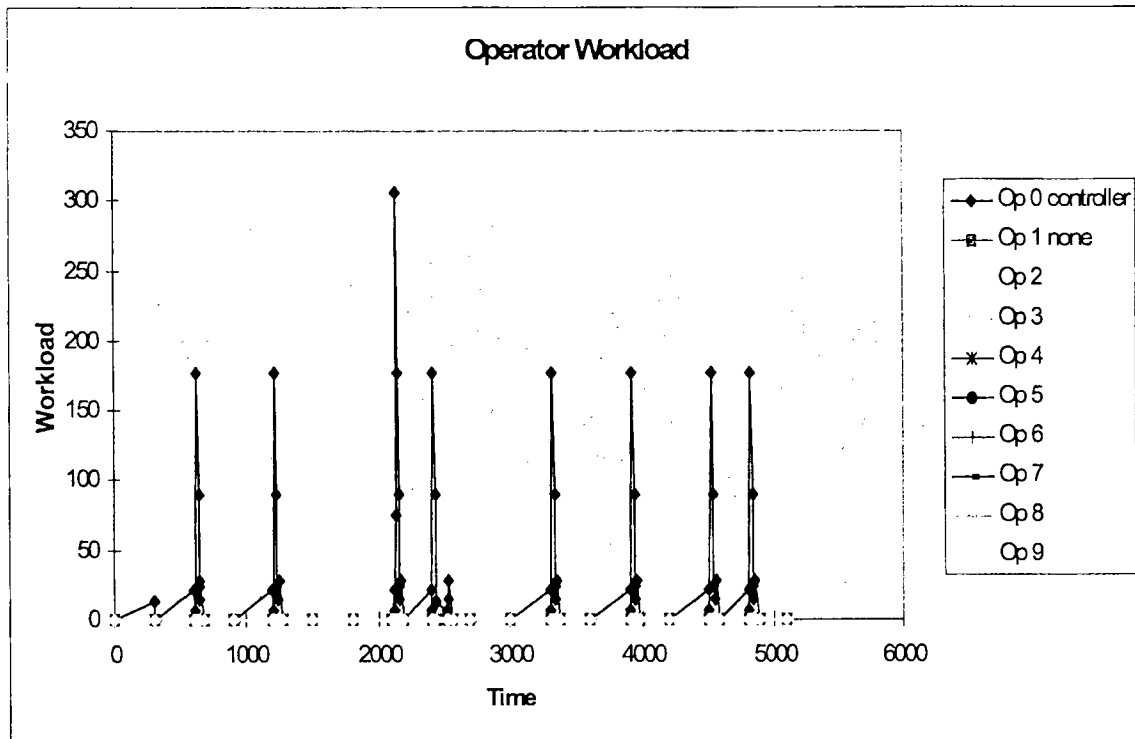

Figure 4-14: Results of a Constructive Simulation Showing Operator Workload [31]

Figure 4-14 shows the results of a simulation depicting operator workload throughout the mission. It clearly shows that although the controller (Op 0) has a low average workload, there are peaks of activity that exceed human capability. The analyst can then go into the model to determine what is happening at those times and re-allocate some of the workload to another individual. The model can then be executed again to see if the modifications were successful.

Measures of Effectiveness Definition

MOE are derived by the analyst from the models and simulations used in this phase of the work. M&S does not play a direct role in the representation of these measures, only in defining them.

At this phase in the analysis, the 'as-is' system is very well understood. The analyst is capable of seeing exactly where the problems with existing system lay and where the capability deficiency is most apparent.

4.2 Develop a Capability Vision

4.2.1 Focus

A strategic vision should be prepared from the evaluation of alternatives, in order to address the long-term Capability Objectives for improving the Architecture in terms of Operating Procedures (Doctrine & Tactics), Organizational Realignment, or System Enhancements/Evolution. *“This activity must be accomplished concurrently with the initial development of the “Vision” Architecture to identify, evaluate, and select the preferred “Vision” Architecture solution.”* [11].

4.2.2 Activities

Evaluate Availability of Technology

An important step in the acquisition process is the evaluation of available technology. All too frequently an analysis will be conducted that will be based on technology that does not exist or will not exist for a significant period of time. *“This only results in a significantly wasted investment early in a program where the work has to be redone in order to reduce the scope to achievable results or else it significantly increases the cost of the resulting acquisition as the onus is put on industry to produce the technology. By evaluating the availability of technology with respect to the project timeline, achievable goals can be reached and the risk of not having the technology available is significantly reduced ”* [9].

Evaluate Doctrine & Tactic Evolution

Doctrine and tactics are continually evolving, with and without the employment of new equipment. Doctrine and tactics evolution is often achieved through a bottom-up approach as actual operational personnel in the field try different techniques in an effort to better leverage their existing equipment and manning levels. The activities in developing the strategic vision must take into account these efforts and extend them to include the strategic vision.

Evaluate Force Structure Evolution

Force structure is described as *“the number, size and composition of the units that comprise the CF”* [11]. The evolution of this Force structure is done in conjunction with Doctrine and tactical evolution in order to obtain optimal effectiveness.

Document the Strategic Vision

Once the Alternative "Vision" Architectures has been evaluated, the preferred solution is selected and the strategic vision is documented to provide the long-term strategy for evolving the Business Architecture. This strategic vision guides the development of the Transformation Roadmap which establishes the strategic "plan" and investment profile for the accomplishing of the evolution of the Business Architecture.

4.2.3 Role of M&S

Technology Assessment

It is important to keep in mind during the development of the strategic vision that it must be achievable. One of the critical areas that often constrains new concepts or ideas is the availability of technology. Because the development of the strategic vision is done concurrently with developing a Vision Architecture, there must be numerous iterations between the two. As the candidate Vision Architectures are flushed out, the availability of the technology must be assessed.

As M&S becomes more and more integrated into the acquisition process, industry is more motivated to produce computer-based models of their developing technology. Not only is it possible to better understand the new technology through the use of advanced visualization techniques and advanced modeling, but it is also possible to simulate the new technology within a much larger system, and perhaps even take it into a virtual war. In traditional programs within Canada, it was typical to do 'try and buy', where the military would purchase one or two systems, often prototypes, to evaluate. If evaluations of the prototype systems were successful, the military would then go out to full-scale procurement of the technology. This is obviously a very time consuming process and extremely expensive. With modern M&S techniques, it is now possible to assess the technology in SE and then be able to conduct the 'try and buy' in SE prior to entering the full-scale acquisition stage.

Figure 4-15 describes an architecture for a Tactical Helicopter Simulator where each module is made up of many individual Plug-In components. A virtual configuration of the aircraft can be represented within the simulated environment and then 'tried out' by operational personnel. In this figure, the Weapon System is being assessed by evaluating different models from different vendors.

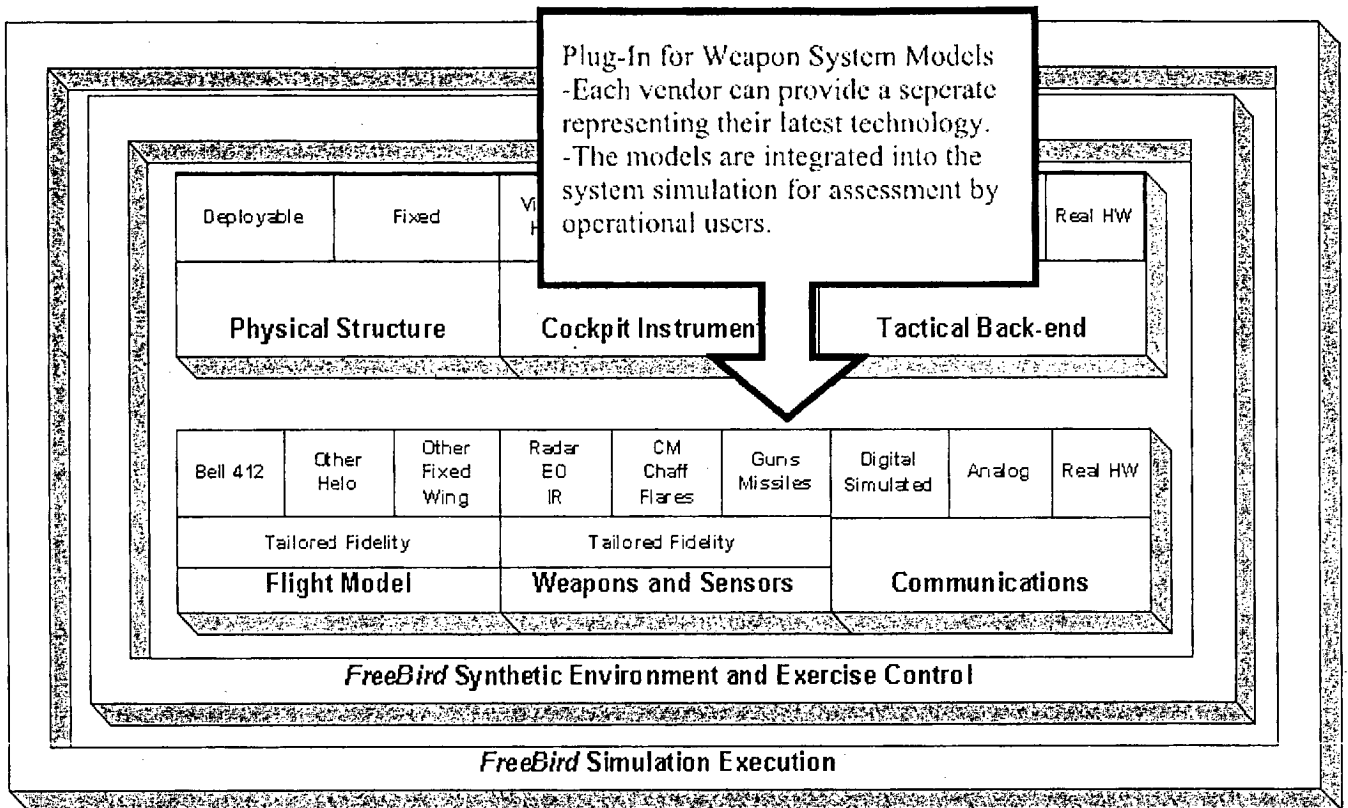

Figure 4-15: Example of Technology Assessment in SE [32]

Doctrine & Tactics Development

As mentioned previously during the assessment of the 'as-is' integrated architecture, it is important to identify the impact of doctrine and tactics on the capability deficiency. Often as a result of assessing the organizational structure, the information flow, and the existing physical model, it becomes clear that a change in doctrine or tactics may satisfy the capability deficiency. There are two areas where doctrine and tactics evolution are considered. The first would be on how to rebuild or redefine the doctrine and tactics to satisfy the existing capability deficiency without the procurement of new material, systems or equipment. The second is to determine the current trends in doctrine and tactics evolution and to identify the Vision Architecture that will function effectively within the new environment.

M&S is particularly effective in the evaluation of doctrine and tactics. It is a technique that has been applied since the beginning of warfare, and can be as simple as writing in the sand. With modern M&S techniques it is possible to evaluate doctrine and tactics through the full range of military conflict within a SE. Constructive simulation is often used in the early stages to assess which

doctrine and tactics are most effective. The environment will then be switched over to virtual simulation within a SE where operational personnel are used. It is now possible to use actual systems such as hardware in the loop and operational personnel operating them or synthetic systems referred to as human in the loop. By combining these environments with models of what the perceived threat will be in the future, and it is now possible to see whether the doctrine and tactics are appropriate.

Figure 4-16 shows a tactical situation display from a simulation being conducted using STAGE™. Each of the players within the scenario represent real-world entities and are a combination of computer generated forces and human-in-the-loop simulations. The new tactics for the computer generated forces can be programmed directly into entity behaviour scripts so that the effectiveness can be assessed. Different scenarios can be developed for a full range of potential missions to ensure that the tactics and doctrine are optimized.

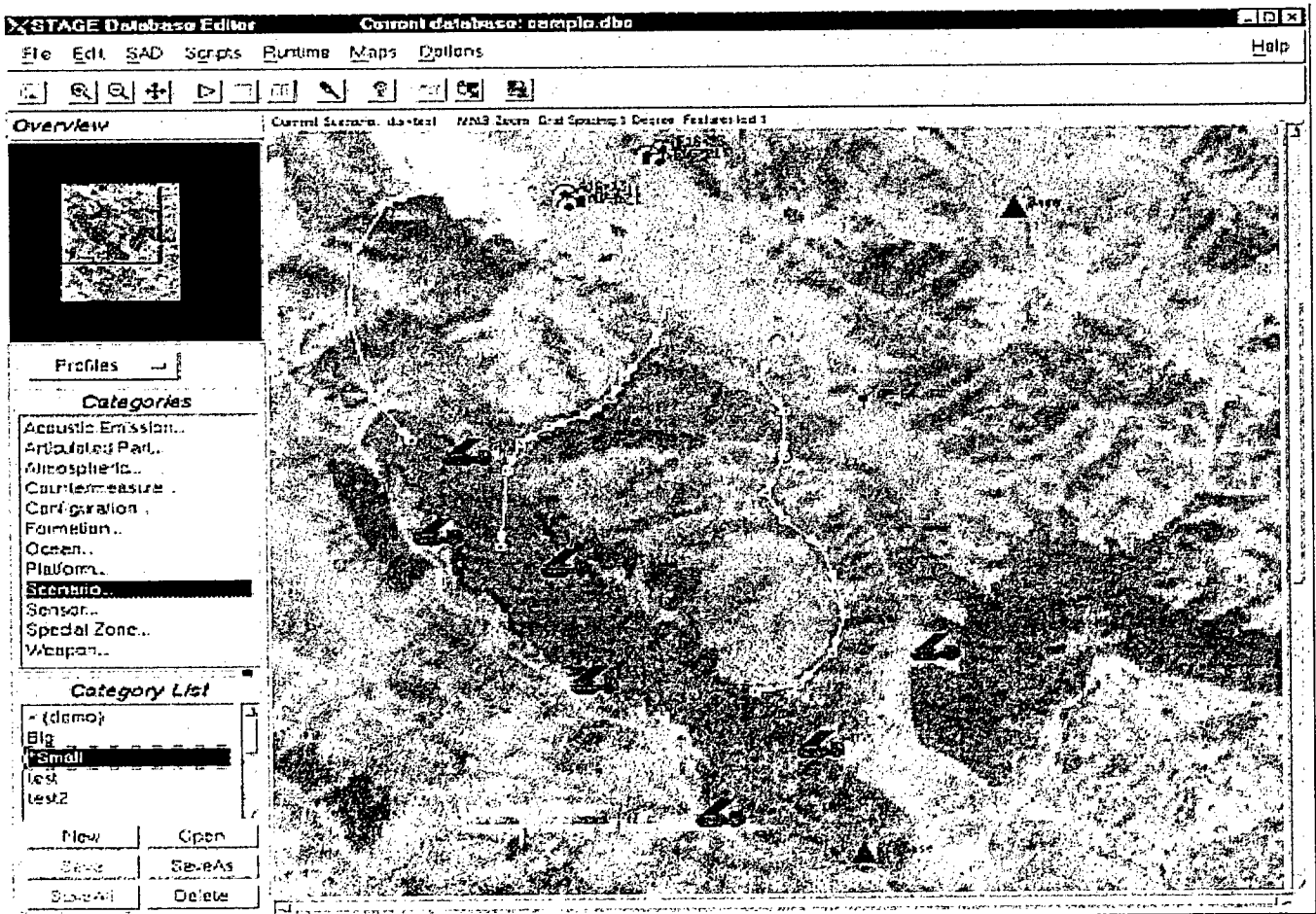

Figure 4-16: Tactical Scenario for Doctrine & Tactics Assessment (STAGE™) [33]

Force Structure Development

Doctrine and tactical evolution is dependent upon the force structure. It is necessary to analyze the future force structure in conjunction with the doctrine and tactics evolution. It is the two combined that will determine what the effectiveness of the military is.

The starting blocks for the assessment of the force structure come from the analysis of the organizational structure done for the 'as-is' integrated architecture as well as the operational personnel and manning analysis. As with the evaluation of doctrine and tactics evolution, there really are two areas to identify. The first area to evaluate is whether modifications to the existing force structure can alleviate the capability deficiency. The second is to determine the best force structure based upon the development of the Vision Architecture. As with the rest of the steps in developing and documenting the strategic vision, it is important to run in parallel with the development of a Vision Architecture. Many iterations between the two are required in order to be most effective.

The use of constructive simulation techniques are very common in determining the effectiveness of force structures. Many different types and compositions can be analyzed very quickly and the effectiveness of their outcomes evaluated. As with the development of doctrine and tactics, it is then possible to take the best options and move them into a virtual simulation within a SE employing hardware in the loop and humans in the loop. The evaluation of force structure evolution is particularly important when developing new command-and-control systems. The flow of information throughout the organization is critical, as well as the processing of the information at each step of the process. M&S techniques are particularly effective in representing each of these minute steps and fully analyzing information flow and processing throughout the entire system.

Figure 4-17 shows a hypothetical Force Structure and how that force would fight in a conceptual engagement. Once the organizational structure and the Concept of Operations is worked through on paper, the system can be assessed using simulation. Using tools such as STAGE™ (Figure 4-16), the new concept can be programmed in and then assessed against many possible scenarios.

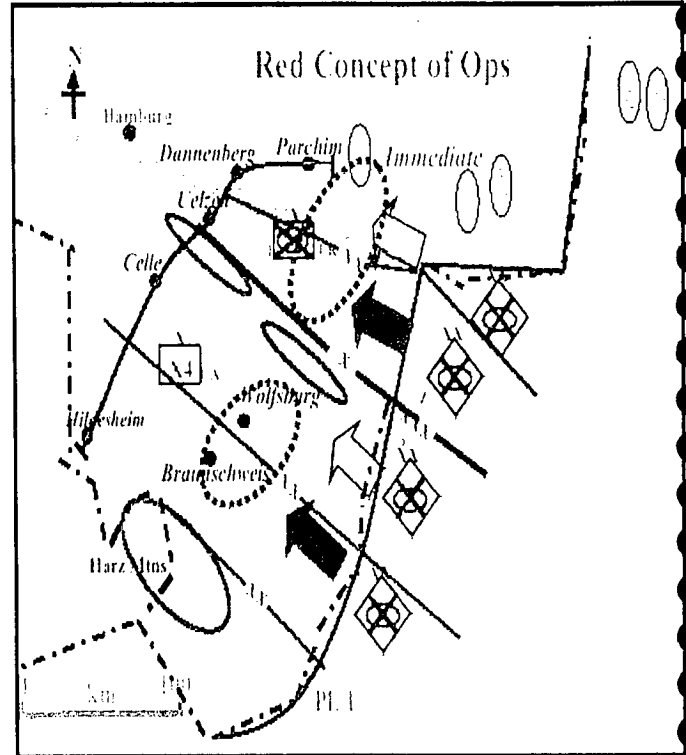
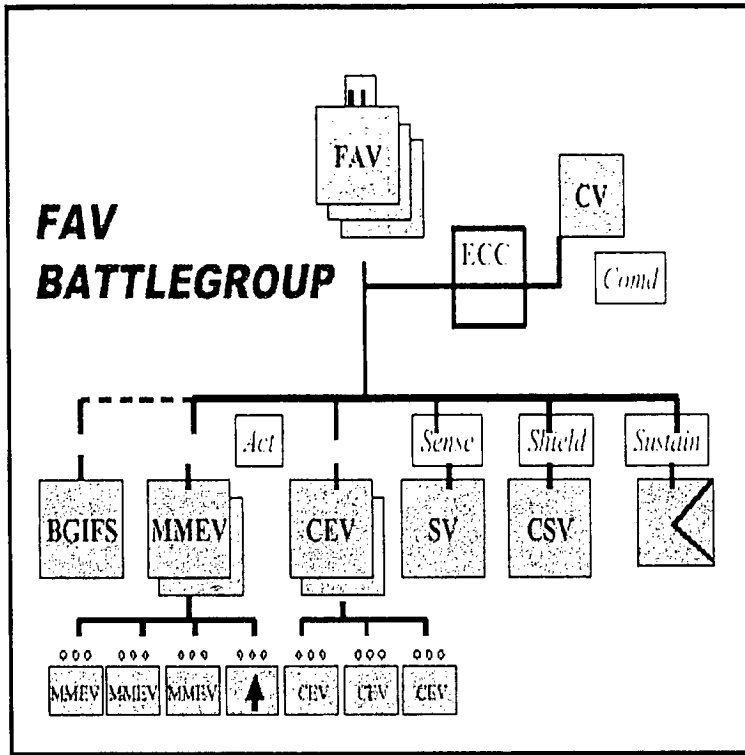

Figure 4-17: Example Conceptual Force Structure [34]

Documentation

An important aspect of documenting the strategic vision is the clear and concise communication of what it is. By translating all the hard work done in the M&S activities back into the written word, the strategic vision becomes open for misinterpretation. To prevent this misinterpretation, Models & Simulations used to develop the strategic vision should be included with the resulting documentation. By including clearly defined models within the strategic vision document as well as visualizations from the simulation activities, it is possible to more clearly visualize and communicate exactly what it is.

4.3 Develop an Architecture

4.3.1 Focus

The “Vision” Architecture represents the Business Architecture and the inherent “capabilities” this architecture provides. This Architecture is described in terms of Organizational Structure, roles & responsibilities, Business Processes, and the “modernization” associated with the Organizations in terms of systems and equipment. The Architecture is documented in a similar fashion as the “as-is” Integrated Architecture with an Operational Model, describing the business processes, and a Physical Model describing the Facilities/platforms, systems, interfaces and operators [11].

4.3.2 Activities

Identify Candidate Vision Architecture Alternatives

There are always multiple approaches for improving the Business Processes, so the various alternatives should be identified as candidates for consideration.

Evaluate Candidate Alternatives for Feasibility

The initial candidates should be evaluated to reduce the number of alternatives selected for detailed evaluation due to feasibility, costs, or performance considerations.

Select Alternative(s) for Concept Development

It may be necessary to pursue multiple alternative “Vision” Architectures to assess the “Value- added” with each alternative, and select the best approach for evolving the Business Architecture. Initial Conceptual Architectures may be developed to support evaluation.

Develop Alternative(s) Operational Model

The Operational Model should reflect the organizational changes (force structure) and process alterations desired to provide improved capabilities.

Develop Alternative(s) Functional Model

Based upon the Operational Model, alternative Functional Models can be developed. The Functional models needs to be decomposed to a level where the functions or tasks are recognizable and can be allocated/assigned to a system or human operator, and the specific information (inputs & outputs),

resources and timing/performance requirements can be allocated to each function or task.

Develop Alternative(s) Physical Model

The Physical Model depicts the arrangement of legacy and new facilities/platforms, systems, operators and interfaces. This establishes the linkages necessary to identify how organizational personnel utilize systems to execute the activities and accomplish the business processes defined in the Operational Model. From this Physical Model the remainder of the Architecture Framework System Views can be generated.

Evaluate Alternative(s) Cost / Effectiveness

The Alternative are evaluated to assess their “value-added” to the enterprise, assess risks to implementation, and provide a analytical basis for decision making.

Select and Document the Preferred Alternative

The preferred solution is selected and refined to resolve any outstanding issues/risks. The architecture for the selected alternative is finalized.

Document the Vision Architecture

The preferred solution is documented.

4.3.3 Role of M&S

Identification of Architecture Alternatives

The initial identification of architecture alternatives is often a difficult task. Without having completed the analysis of the Vision Architecture, the analyst does not know exactly what is required. It is a bit of the chicken and the egg story. The important part is to define some initial options that can be assessed. Once the analysis continues, it will become apparent which options are viable and which ones are not. The Canadian military expends a great deal of effort on analyzing the architectures of our allies. This has two benefits, it gives us insight into what works and what will not, as well as it allows us to leverage the investment made by our allies. A side benefit, but also an important consideration, is interoperability. Often our capability deficiency cannot be satisfied in isolation from our allies, we must address coalition operations, and interoperability of systems is key to the success of any coalition operation. As warfare becomes more and more technology centric, this factor is increasingly important.

M&S can be used in various ways during this step of the process. We can often leverage existing M&S investments made by our allies and in some

cases reuse the technology. M&S also allows us to conduct high-level analyses of options to quickly identify which architectures will work and which will not. The investment made in M&S activities during the identification of the 'as-is' system can often be quickly modified to address technology alternatives. The use of constructive simulation for high-level analyses can be very beneficial.

Feasibility Assessment of Alternative Architectures

Once the alternative architectures have been selected, it is then necessary to evaluate them within a much larger system to determine if they are feasible or not. Even at this early stage, the MOE should be utilized to determine the degree of success of the new architecture. Prior to having a fully developed operational, functional and physical model, it is only possible to conduct high-level analysis. Effective use of M&S techniques during this phase of the work will significantly reduce the level of effort required for the subsequent analyses as only those options that are somewhat viable will be worthy of further investigation. The sooner nonviable alternatives can be eliminated, the better the return on the acquisition investment. This is not to say that alternatives should not be fully evaluated before deselecting them but more to say that the process should be efficient and timely so that time and money are not wasted down stream. The Vision Architecture provides the foundation for the rest of the analysis so is important to get it right.

Alternative Operational Model Development

The development of alternative operational models must be done in conjunction with the evaluation of the force structure evolution. It also involves utilizing the doctrine and tactics evolution described in the previous activities as well. During this step of the process, detailed models of each viable alternative should be developed. This would involve alternate organizational structures as well as various concepts of operation.

Alternative Functional Model Development

Once the architecture has been defined as well as the operational model, it is then possible to conduct a functional decomposition of the Vision Architecture. It may be possible to build upon, or modify, the 'as-is' functional decomposition. By utilizing the same methodology within the 'as-is' there will be benefits downstream when comparisons are made to determine the improvements in effectiveness from the old to the new. The functional decomposition would also continue down to function allocation, where the smallest quantifiable functions are allocated to man or machine based upon the vision of the 'to-be' system. As with the 'as-is' analysis, information flow should also be represented within the new model.

As the analysis proceeds, it will be necessary to go back and modify the candidate vision alternatives and perhaps the doctrine and tactics evolution

and force structure documents. This is an iterative process that must be done effectively in order to achieve usable results. As mentioned at the start of this section, it was determined that it is very difficult to identify intended architecture alternatives as it is unclear what the end state would be. As the analysis proceeds and the end state becomes more and more clear, the previous material must be updated and modified to reflect this new knowledge and the associated dependencies must be modified as well. The goal is to end up with well-defined alternatives involving not only a Vision Architecture but their associated force structures, doctrine, and tactics. It is important not to assess the technology in isolation.

Alternative Physical Model Development

During the CEP, only the initial physical models will be developed. These models will only be developed in sufficient detail to allow a single Vision Architecture to be selected. To determine which ones are most effective and which ones are not, it is often necessary to conduct the first iteration of the virtual life cycle within the CEP. With respect to M&S, it is also important to select the appropriate tools and technologies that will allow the extension of the physical model into the engineering environment, during the evolutionary acquisition phase. This is not always possible, but is highly desirable to reduce rework downstream.

Evaluate Cost / Effectiveness

Once each candidate Vision Architecture has been defined, it is then necessary to evaluate the effectiveness of each option. It is also critical at this stage to assess the impact of cost for each alternative. By developing models in simulations that have cost attribute data embedded within them, it is possible to determine the net cost of each option and compare the improvement in effectiveness over the 'as-is' system. It is important to go back and use the MOE defined in the first step of the CEP to ensure that the capability deficiency is truly being met by each alternative and only assessing the cost associated with each viable alternative. Upon further analysis it may be determined that all of the alternatives are cost prohibitive and that the scope of the project must be reduced. Rather than tackling the large capability gap, it may only be possible to tackle a portion of the capability deficiency. At this point the previous documents, models and simulations would have to be updated to reflect the reduced scope and to identify new MOE to address the smaller capability deficiency.

Figure 4-18 shows a simple tool that allows the Urban Operations Training Center project staff to 'drag and drop' buildings into a model of the CFB Wainwright range area. The buildings are selected and positioned based upon the requirements for conducting urban operations training. Once the project staff has developed a good configuration, they can immediately see the cost of the project. If they are over-budget, they can substitute less expensive buildings or build fewer roads. If they are under-budget, they can add

additional buildings that will allow more training options. This ability to see rough-order-of-magnitude (ROM) costs during the planning phase significantly speed up acquisition time as many iterations through the project financial . This ability to see rough-order-of-magnitude (ROM) costs during the planning phase significantly speeds up acquisition time as many iterations through the project financial support team are no longer required.

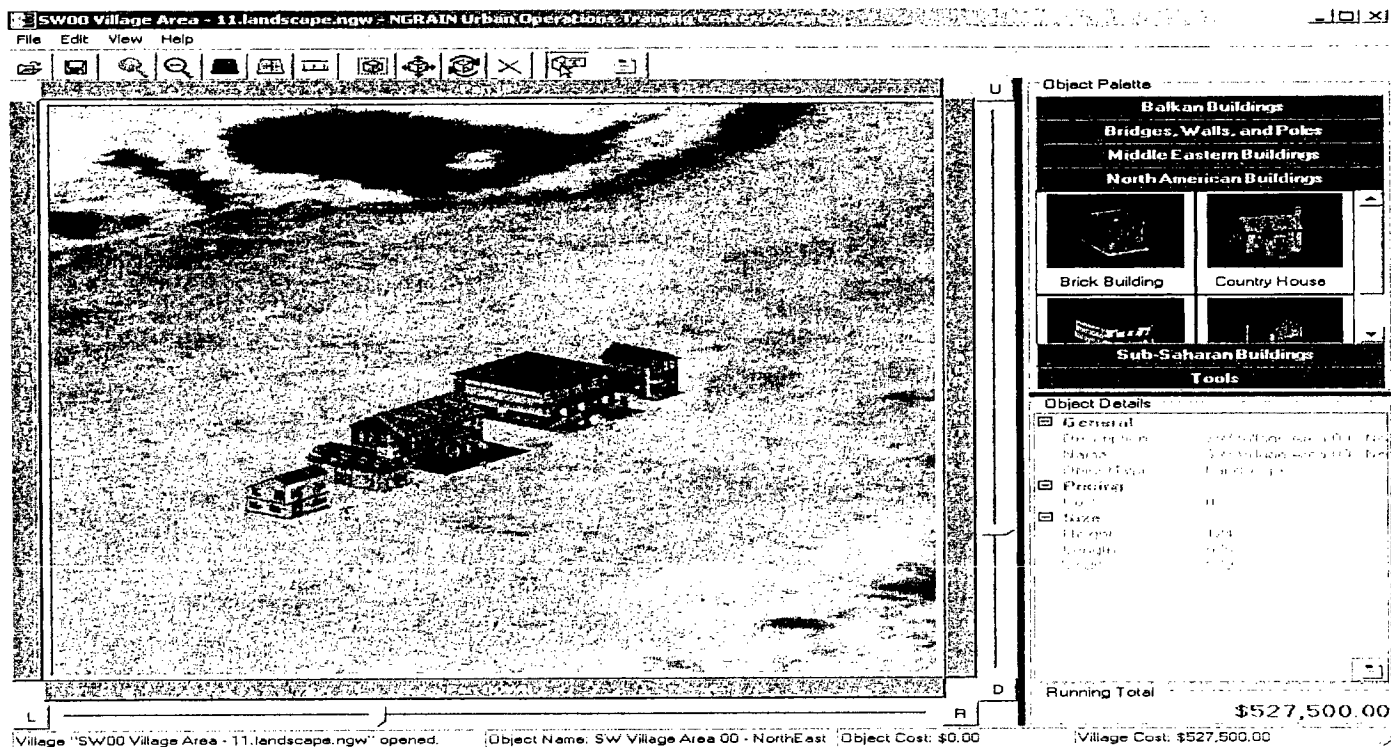

Figure 4-18: Example of Modeling Tool with Embedded Costing Data [35]

M&S is particularly effective in conducting these types of analyses. Based upon the future perceived threat, many scenarios can be developed within a SE with the new system to be taken to war. Each of the options can be assessed in many different environments very quickly using constructive simulation techniques. Once the alternatives become more and more refined and the options are down selected to only one or two remaining, the trials can be conducted using virtual simulation with existing hardware and humans in the loop. M&S data collection technique can be used to effectively capture performance measures and cost metrics throughout the exercises. It is also important to note that as a result of these activities, shortcomings of the Vision Architecture will be identified that must be addressed immediately. This would involve the updating of the previous documents so that they accurately reflect what the 'to-be' system would look like. Once again it is an iterative process that requires not only updates to the physical and functional models but also the doctrine, tactics, and force structure documents. It is also important to note at this phase, the role of verification

and validation. The results of the simulation will only be as good as the validity of the data supplied.

Document the Vision Architecture

As described in the documentation of the strategic vision, it is important to document the Vision Architecture in a clear and concise manner. Many options should have been assessed prior to the selection of a final Vision Architecture so it is important to document why this particular option was selected. As well, the Vision Architecture should have been 'fine tuned' to ensure that it is optimal. These modifications should be documented along with their rationale so that when the system is implemented, the systems engineering team understands the rationale and intent of the resulting Vision Architecture. As with the documentation of the Strategic Vision, it is important to convey a clear understanding the concept and it is highly recommended to include models and simulations with the resulting documentation.

4.4 Establish the Transformation Roadmap

4.4.1 Focus

The Transformation Roadmap establishes the strategic plan for accomplishing the strategic vision.

4.4.2 Activities

Identify the Organizational (Force) Structure Evolution Plan

This section of the Transformation Roadmap addresses the changes to the Organizational structure and associated Roles and Responsibilities, and the time frame when these changes are to be implemented.

Establish Capability Evolution Objectives

This section of the Transformation Roadmap addresses the evolution of Capabilities/Performance objectives over time with each incremental step in evolving the Integrated Architecture.

Establish the Evolutionary Acquisition Roadmap (Risk Mitigation)

This section of the Transformation Roadmap addresses the Evolutionary Acquisition Program(s) which will be established and authorized to realize the Capability Objectives and Strategic Vision.

Establish the Force Training & Transition Plan

This section of the Transformation Roadmap addresses the Force training requirements and the transition plan required to adequately field the new capability within each incremental step.

Establish the Investment Plan

This section of the Transformation Roadmap provides the investment plan to support the development, the delivery, the sustainability and the disposal of the new capability (from “cradle to grave”).

4.4.3 Role of M&S

Organizational Evolution Assessment

Because the development of the Vision Architecture is focused entirely on the future system, there is typically a large gap between the 'as-is' system and the 'to-be' system. M&S activities conducted during the development of the Vision Architecture can be used along with models from the 'as-is' system to develop a transition plan. Models and simulations can be built for achievable incremental steps towards the Vision Architecture. Each one of the steps can be assessed in a simulation environment for feasibility and effectiveness.

Capability Evolution Assessment

Each incremental step towards the Vision Architecture improves the overall capability and closes the capability gap identified by the statement of operational capability deficiency. M&S activities conducted at this phase of the analysis determine the incremental improvement in capability during the transition from the 'as-is' to the 'to be' system. This may be an extremely important function in the overall process if large capability gaps must be filled quickly and cost effectively during the first few incremental steps.

Force Training & Transition Planning

Because each of the incremental models will determine the force structure required at each step along the way, it is then possible to determine the training requirements to achieve this new capability. It is also important to note that M&S activities performed along the way make good training applications during the transition. This is particularly true if large-scale constructive simulations and virtual simulations are used along the way. The M&S environments in support of tactics and doctrine development can be easily reused as training tools for the new personnel. Large-scale virtual simulations involving many forces are also extremely beneficial in that they provide training to the new personnel within that vision system as well as all the other agencies that will be interacting with this new system.

Establish the Investment Plan

M&S activities do not directly contribute to the investment plan. It is the results of the M&S activities that provide the content and justification for the investment. It is important that in each step of the process, that the data be verified and validated to ensure that the final investment plan is realistic and credible.

4.5 M&S Tools in CEP

When exploring M&S tools to support the CEP, a variety of standalone software products can be found along with some tool suites such as Business Process Analysis (BPA) products. These CASE Tools offer integrated M&S functionality to help define the “*who, what, when, why and how*” things are happening within an organization. The major BPA vendors provide extensive and flexible modeling tool sets, process simulation, collaborative environment, and centralized model-based repositories to promote re-use and sharing among users.

As previously mentioned in Section 3, the US Government has been enforcing for the past few years the use of BPA tools with its Agencies and Contractors to help streamline the architecture development process. Tangible results have been obtained as of today, and considerable efforts are still being invested in the evolution of BPA tools and processes to better support military acquisition activities. Within this context, it is believed that some of the BPA tool benefits would also apply to the CEP. Further BPA product analysis is perhaps required in order to better measure these potential benefits.

Annexe D summarizes the M&S tool usage within the different preliminary CEP activities definition¹⁴.

¹⁴ At the writing of this report, it was not possible to analyze each product individually. This product mapping is completed to the best of our knowledge available.

5. Conclusion and Recommendations

The CEP is one of the CapDEM TDP expected outcomes aimed at efficiently integrating M&S and SysEng processes to optimize how DND/CF military capabilities are defined, acquired and managed throughout their existence.

The current document has presented how M&S tools and techniques could be exploited within the preliminary definition of the CEP and its respective activities. Before doing so, some fundamental concepts and elements related to the use of M&S within military acquisition programs were introduced. The report also provided some M&S tool examples that can be considered to support the preliminary CEP definition.

Since the CEP definition is still at a very early stage, this report may be considered as a first step in defining the role of M&S in the CEP. As the CEP matures, the role of M&S should progressively be refined as well. Furthermore, as the DND/CF intention is to globally manage M&S across the entire acquisition life cycle, through the “institutionalization” of SBA [6], the role of M&S in the CEP will need to tie to the global M&S strategy. Once this global strategy is defined, it should encompass in more detail how the Common SE framework and the shared distributed Modeling and Simulation Resource Repository (MSRR) will be developed within DND/CF, in order to promote re-use and consequent efficiencies “across the board” [16].

As presented in Section 2, the CEP is one capability-based process among others within the larger DND/CF capability life cycle that is supported by M&S tools and processes. In order to efficiently implement the notion of collaboration and sharing across the life cycle, there is a great need to define how M&S activities, and its relevant data, must transit from one phase (or process) to an other. The objective is to maximize benefits from M&S within the capability life cycle as a whole as well as within each individual phase. M&S implementation details across the capability life cycle will particularly be defined as the Integrated Product and Process Development (IPPD) and the Collaborative Engineering Environment (CEE) concepts are integrated into the capability acquisition process. The anticipated benefits from the use of M&S will mostly be observed in the subsequent phases of the CEP until the capability life cycle has been completed (disposal). Therefore, the M&S resource investment required to implement a specific Simulation Support Plan (SSP) will need to take into account all the activities involved in a capability life cycle (definition, development, training, sustainment and disposal).

As for candidate M&S Tools to support the CEP, the tools selection cannot happen without considering the greater framework within which they will be deployed. This document does not go into any detail on the supporting technologies and processes that will allow M&S Tools to work effectively within the CEP. Current trends such as collaboration, interoperability, MSRRs, data standards, interchange formats, HLA and the like should also be investigated further. These technologies, processes and standards will form the glue that will bind the suite of M&S Tools together to achieve the objectives of the CEP.

From what has just been said, it is believed that the following elements represent valuable areas of opportunity to investigate in order to better define the role of M&S in CEP:

- Obtain the most recent DND/CF strategy and plans with regards to the implementation of SBA, IPPD and the CEE concepts to support the capability life cycle;
- Obtain the most recent DND/CF strategy and plans with regards to M&S planning, development, use and management enterprise wide;
- Once the CEP has been properly situated in the acquisition process and its activities properly defined, upstream and downstream phases should be analyzed in order to identify common M&S objectives and define how they should be addressed. This will particularly help to better define how the Simulation Support Plan (SSP) should be developed and managed across the life cycle.
- Refine the role of M&S within the latest CEP definition within its global (enterprise) context.
- Create a synergy with other DND/CF initiatives related to M&S use within the capability acquisition process.

6. References

- [1] National Defence, Minister's Advisory Committee on Administration Efficiency, "Achieving Administration Efficiency", August 21, 2003.
- [2] J. Hollenbach, "A framework for enabling SBA", May 2001. Available at <http://www.dtic.mil/ndia/2001sbac/hollen.pdf>
- [3] P.L. Eirich, J.E. Coolahan, "A collaborative Environment Architecture for Future Combat Systems (FCS) Modeling and Simulation", 2002. Available at http://www.msiac.dmsi.mil/sba_documents/Collab%20Environment%20for%20FCS%20M&S.pdf
- [4] DRDC Valcartier, CapDEM TDP fact Sheet IS-224-A, 2003-10. Available at http://www.drev.dnd.ca/poolpdf/e/162_e.pdf
- [5] NATO Modeling and Simulation Group (NMSG), "M&S Technology in Support of Simulation Based Acquisition (SBA)", December 2001.
- [6] DND/CF Concept Paper by the Symposium Working Group, "Creating the CF of 2020 – Concept Development and Experimentation and Modeling and Simulation", 1 Nov 2000. Available at <http://www.vcds.forces.gc.ca/dgsp/pubs/rep-pub/dda/symp/cde>
- [7] DoD, "Systems Engineer Fundamentals", Jan 2001. Available at <http://www.dau.mil/pubs/pdf/SEFGuide%2001-01.pdf>
- [8] L.K. Piplani, J.G. Mercer, Richard O. Roop, "System Acquisition Manager's Guide for the use of Models and Simulations", Report of the DSMC, September 1994. Available at http://www.dau.mil/pubs/mfrpts/pdf/mod_sim.pdf
- [9] DoD Executive Council for Modeling and Simulation (EXCIMS), "Joint Simulation Based Acquisition Task Force Roadmap for SBA", December 1998. Available at <https://www.msiac.dmsi.mil/sba/generalinfo.asp>
- [10] AMSO, "SMART Planning Guide-SPG", Sep 02. Available at <http://www.amso.army.mil/smart>
- [11] R.Schmidt, "Overview of the Capability Engineering Process", June 2003.
- [12] Defense Acquisition University (DAU), "Acquisition Modeling and Simulation Comprehensive Core Body of Knowledge (CCBK)", November 1998. Available at http://center.dau.mil/Topical_Sessions_templates/Modeling_and_Simulation/Reference_Materials/981112ccbkc.doc
- [13] DAU, "DAU PROGRAM MANAGERS TOOL KIT", Twelfth Edition (Ver 1.0), December 2002. Available at

- http://www.msiac.dmsi.mil/sba_documents/PM%20Toolkit%20Dec02.pdf
- [14] DoD, "DoD - The Army Model and Simulation Master Plan", October 1997. Available at http://www.msiac.dmsi.mil/sba_documents/Army%20M&S%20Master%20Plan.pdf
- [15] AIR FORCE INSTRUCTION 16-1002, "MODELING AND SIMULATION (M&S) SUPPORT TO ACQUISITION", June 2000. Available at http://www.msiac.dmsi.mil/sba_documents/afi16-1002.pdf
- [16] C.Pogue, L.Vallerand, "A conceptual Model of Military Capabilities and an Integrating Functional Architecture to Facilitate Military Capability-Based Planning", 2003.
- [17] Dr H.K. Fallin, "Simulation Support Plan Guidelines", 1997. Available at http://www.msiac.dmsi.mil/sba_documents/Army%20Sim%20Support%20Plan.doc
- [18] National Defence Headquarters Organizational Chart. Available at http://www.vcds.forces.gc.ca/dgsp/00native/tools/NDHQ_Org_Chart_e.doc
- [19] Use of Helicopters in Land Operations. Available at http://armyapp.forces.gc.ca/38cbg_arsd/CD/artc/MLP/401/401.08OrgTacAvnSq.n.ppt, slide 8
- [20] Adapted from Exercise Active Edge Presentation. Available at http://www.army.forces.gc.ca/lfwa_hq/Active_Edge/Docs/MPC_PTA_Presentation.pps
- [21] From Air Force Command & Control Information System Functional Decomposition Analysis Project, DRDC Valcartier, 2002, Scientific Authority: Valdur Pille.
- [22] Screenshot from MS Access™ Database, 2001, The HFE Group, From CF18 Information Flow and Processing Analysis Project, DRDC Toronto, Scientific Authority: Brad Cain.
- [23] Screenshot from IPME™ (www.maad.com) model, 2001, The HFE Group, from CF18 Information Flow and Processing Analysis project, DRDC Toronto, Scientific Authority: Brad Cain.
- [24] Screenshot from WinCrew™ application, 2001, Micro Analysis and Design. Available at <http://www.maad.com/>
- [25] Screenshot from MS Access™ Database, 2001, The HFE Group, from CF18 Mission Function and Task Analysis, DRDC Toronto, Scientific Authority: Brad Cain.
- [26] Screenshot from MS Access™ Report, 2001, The HFE Group, from CF18 Mission Function and Task Analysis, DRDC Toronto, Scientific Authority: Brad Cain.
- [27] <http://www.inetres.com/gp/military/ar/uav/Falconet.html>
- [28] http://www.fas.org/irp/doddir/usaf/conops_uav/index.html

- [29] Screenshot of Avionics Prototype Builder™ application, 2004, The HFE Group
- [30] Screenshot from MicroSaint™ Action View. Available at www.maad.com
- [31] Screenshot from MicroSaint™ Operator Workload Report. Available at www.maad.com
- [32] FreeBird™ Simulator architecture graphic, 2003, The HFE Group.
- [33] Screenshot of tactical scenario in STAGE™, 2000, eGENUITY. Available at <http://www.engenuitytech.com/products/STAGE/index.shtml>
- [34] Directorate of Land Strategic Concepts, Future Army Experiment, Operations in the Expanded Battlespace, 2001. Available at http://armyapp.dnd.ca/dlsc-dcsot/docs/English_EXFOR.pdf
- [35] Screenshot of NGRAIN™ Village Editor application, Application developed for DND Weapon Effects Simulation (WES Project), Urban Operations Training Center ID phase analysis, 2004, Technical Authority: Director Land Requirements 3-6, Maj. Greg Burton
- [36] J.Leclerc, "The Capability Engineering Process (CEP) - Preliminary Guidelines", 2004-02.
- [37] <http://www.telelogic.com/products/doorsers/index.cfm>
- [38] <http://www3.ca.com/Solutions/Product.asp?ID=260>
- [39] <http://office.microsoft.com/assistance/topcategory.aspx?TopLevelCat=CH79001814>
- [40] <http://www-306.ibm.com/software/rational/>
- [41] <http://www.oracle.com/index.html>
- [42] <http://www.sybase.com/home>
- [43] Popkin Software's Federal Systems Division, dedicated to exclusively servicing the needs of US Government Agencies and Gov't Contractors. Available at <http://government.popkin.com/>
- [44] Popkin System Architect's C4ISR option for DoD (Website). Available at <http://government.popkin.com/frameworks/c4isr.htm>
- [45] A.Meilich, "Applying Tools and Methodologies to Develop C4ISR Architecture Framework Compliant Architecture Products", July 2002. Available at http://www.incose.org/chesapek/meetings/Tools_and_Methodologies_for_C4ISR.pdf
- [46] Screenshot from Casewise Corporate Modeler Suite, Process implementation approach. Available at <http://www.casewise.com/products/corporate-modeler/index.php>

- [47] Screenshot from Casewise Corporate Modeler Suite, Enterprise Architecture Model. Availabel at <http://www.casewise.com/products/corporate-modeler/framework.php>
- [48] Screenshot from Popkin System Architect® C4ISR Architecture Framework. Availabel at [http://www.popkin.com/products/system_architect/frameworks/DoDAF%20\(C4ISR%20Framework\).jpg](http://www.popkin.com/products/system_architect/frameworks/DoDAF%20(C4ISR%20Framework).jpg)
- [49] Screenshot from Casewise Corporate Modeler Suite, Enterprise Architecture Model, Business Modeling and Simulation. Availabel at <http://www.casewise.com/products/corporate-modeler/corporate-modeler.php#para2>
- [50] Screenshot from Casewise Corporate Modeler Suite, Process Simulation. Availabel at <http://www.casewise.com/products/corporate-modeler/simulation.php>
- [51] DoD Executive Council for Modeling and Simulation (EXCIMS), “Joint Simulation Based Acquisition Task Force Roadmap for SBA”, December 1998. Availabel at <https://www.msiac.dmsso.mil/sba/generalinfo.asp>
- [52] Screenshot from OneSAF Product Line Architecture. Availabel at http://www.onesaf.org/Large_Common_Brief.pdf
- [53] Screenshot from the “Joint Simulation Based Acquisition Task Force Roadmap for SBA”.
- [54] <http://www.microsoft.com/office/word/prodinfo/default.aspx>
- [55] <http://www.idefine.com/Tutorial/Tutorial%20Sales%20Page.htm>
- [56] Gartner, “Magic Quadrant for Business Process Analysis, 2004”, 4 March 2004, Jim Sinur.

Annexes

Annexe A: M&S Tools Links

Table 7 provides some links to M&S Tools websites.

Table 7: M&S Tool Links

	WEB LINK	DESCRIPTION	REMARK
1	DND/CF Modeling and Simulation Resource Repository (MSRR) http://www.drdc-rddc.dnd.ca/seco/msrr_e.html	This site is maintained by the DND/CF SECO. The site contains a list of modelling and simulation resources that may be helpful to the Defence community.	
2	OR/MS Today http://www.lionhrtpub.com/orms/surveys/Simulation/Simulation.html	Simulation Software Survey The information in the survey was provided by the vendors in response to a questionnaire developed by James Swain. The survey should not be considered as comprehensive, but rather as a representation of available simulation packages. OR/MS Today is the magazine for members of the Institute for Operations Research and the Management Sciences (INFORMS).	Last Update: 2003/08/14
3	DMSO Modeling and Simulation Resource Repository (MSRR) http://www.msrr.dmsi.mil/	The MSRR, comprised of seven nodes, provides simultaneous retrieval of Modeling and Simulation resources. Providers include, this DMSO system, Army, Navy, Air Force, Missile Defense Agency, DIA, C4ISR Decision Support Center Information System & MSRR.	User ID required.
4	DoD Army Modeling and Simulation Resource Repository (MSRR) http://www.msrr.army.mil/	The Army MSRR is part of the DoD-wide Modeling & Simulation Resource Repository (MSRR).	User ID required.
5	Air Force Modeling and Simulation Resource Repository (MSRR) http://afmsrr.afams.af.mil/	The goal of the Air Force Modeling and Simulation Resource Repository is to provide a single source for information about and access to DoD models, simulations, data sources, algorithms, and other M&S resources in order to facilitate reuse and avoid duplication.	
6	Navy Modeling and Simulation Management Office http://navmsmo.hq.navy.mil/index.cfm	This NAVMSMO web site serves as the web-enabled single point of public access to the Navy's Modeling & Simulation Information Service (NMSIS).	
7	INCOSE Tools Database Working Group http://www.incose.org/tools/	The Tools Database Working Group (TDWG) is bringing online an automated tools survey that will allow the tool vendors to directly update their tool information (rather than wait for the TDWG to get	Last update: July 2003

	WEB LINK	DESCRIPTION	REMARK
		together and post the information).	
8	Human Factors Tools Website with Matrix http://www.manningaffordability.com/S&tweb/HEResource/Tool/Tool_list.htm	The tools presented have been identified as applicable to different stages of the human engineering process.	Last update: 1998/09/08
9	A Collection of Modelling and Simulation Resources on the Internet http://www.idsia.ch/~andrea/simtools.html#visim	This is a review of simulation software that does not aim to be complete.	Last update: April 2004
10	Modeling of Complex Physical Systems Tools http://www.modelica.org/software.shtml	Links to Modelling and Simulation Software. A list of software packages for modelling and simulation of dynamic systems. General purpose tools and domain specific ones are mixed in this list.	Last update: 2002/10/21
11	CASE Tools Index http://www.cs.queensu.ca/Software-Engineering/tools.html	This file is an index of CASE tools, sorted by name. It is derived from the same database as the vendor list, and so is only as accurate as that list.	Last update: 2003/03/26
12	Business Process Modeling Tools http://is.twi.tudelft.nl/~hommes/tools.html	This page presents an overview of business process modelling tools that can be found on the internet.	Last update: 2001/06/20
13	Business Process Products and Services http://www.bpmg.org/downloads/Briefing_BPMG_Suppliers_Overview.htm	BPM Solution Providers. 400+ organizations providing products & services. The BPM Group.	

Annexe B: Modeling Tools

Table 8 presents candidate **modeling tools categories** to support the CEP along with some product examples. Note that the product descriptions provided were extracted from the respective vendor web site. It would therefore be advisable to compare each vendor's product description with independent reviews in order to obtain a more complete and reliable appreciation of each product.

Table 8: Modeling Tool Categories and Products

MODELING CATEGORY	TOOL NAME	DESCRIPTION	REMARKS
<i>Organizational</i>			
	Team Flow	<p>Designed to help teams of people to work together smoothly and efficiently, TeamFlow is widely used for a variety of team-based process mapping applications. TeamFlow maps and documents processes quickly and easily and is in use by thousands of companies worldwide since 1989. TeamFlow has become the world's most popular pure <i>Deployment Flowcharting</i> process mapping software package.</p> <p>http://www.teamflow.com/</p>	<p>Combines organizational structure, process and workflow into one tool.</p> <p>Focus is on deployment but has been used for many more applications.</p>
	MS OrgChart	<p><i>Microsoft Organization Chart 2.0</i> is an application that launches from within <i>Word</i> that allows users to quickly and easily create organizational charts for insertion into a document.</p> <p>http://www.cas.suffolk.edu/birtwell/org.htm</p>	<p>This application is embedded within the Microsoft Office Suite, including MS Word, MS PowerPoint and MS Visio.</p>
	OrgPlus	<p>OrgPlus products work together to provide a framework for organizations to create reliable business processes around the discipline of managing and communicating organizational structure and change.</p> <p>The overall objectives of such processes are to enable management to:</p> <p>Make decisions with respect to organizational structures and resource allocations,</p>	<p>Enterprise level tool that encompasses not only descriptions of the existing organization but also the ability to help when doing scenario based planning.</p>

MODELING CATEGORY	TOOL NAME	DESCRIPTION	REMARKS
		<p>Provide a framework for planning for change and measuring financial and operational effects; and</p> <p>Communicate structural and operational information to all employees.</p> <p>http://www.orqplus.com/solution/index.htm</p>	
	MS Visio	<p>Visio 2003 is a diagramming program that can help you create business and technical diagrams that document and organize complex ideas, processes, and systems. Diagrams created in Visio 2003 enable you to visualize and communicate information clearly, concisely, and effectively in ways that text and numbers cannot. Visio 2003 also automates data visualization by synchronizing directly with data sources to provide up-to-date diagrams, and it can be customized to meet the needs of your organization.</p> <p>http://www.microsoft.com/office/visio/prodinfo/overview.mspx</p>	<p>Visio provides one of the richest and most extensible suite of templates to support most of the modeling standard and conventions (Organization modeling, Process modeling, Software engineering, Database, Network, Project Management, etc.).</p>
Business Process			
	AllFusion Process Modeler (formerly BPWin and ERWin)	<p>AllFusion Process Modeler is a powerful modeling tool that can help analyze, document and improve complex business processes. A process model can enable you to clearly document important factors such as which activities are required, how they are performed and controlled and what resources are needed to perform them. This provides an integrated picture of how your organization accomplishes tasks, from small department workflows to complex organizational functions.</p> <p>http://www3.ca.com/Solutions/Product.asp?ID=254</p>	<p>This tool has been used extensively by DND to model the existing organization. It supports the common IDEF0 modelling standard as well as IDEF1x and IDEF3.</p> <p>DRDC Valcartier used the tool extensively in the completion of the Air Force Command and Control Information System (AFFCIS) definition phase. The project modeled the entire Air Force from 1 CAD down to an individual crewmember signing out an aircraft.</p>
	CORE	<p>The CORE product family provides a flexible combination of modeling and simulation tools supporting product and process engineering. CORE's object-oriented environment delivers the same functionality from a single user workstation to large, distributed, client-server teams. CORE runs</p>	<p>It is one of the suites currently being assessed by DRDC on the CapDEM TDP.</p>

MODELING CATEGORY	TOOL NAME	DESCRIPTION	REMARKS
		under the Microsoft Windows® environment. http://www.vtcorp.com/productline.html	
	Workflow Modeler	WorkFlow Modeler is the authoring tool in Meta Software's suite of tools for performance improvement. It provides a robust, consistent method for building models of business processes, and, through its integrated link with the MetaSoft Works simulation application, provides the foundation for in-depth process analysis. http://www.metasoftware.com/products/wfm.asp	Supports standard modeling notations including cost modeling. The models can also be 'run' using a simulation package called MetaSoft Works.
	MagicDraw™	MagicDraw is a visual UML modeling and CASE tool with teamwork support. Designed for Business Analysts, Software Analysts, Programmers, QA Engineers, and Documentation Writers, this dynamic and versatile development tool facilitates analysis and design of Object Oriented (OO) systems and databases. http://www.magicdraw.com/main.php?ts=naviq&NMSESSID=18b7ff670d89ee5b237c17ebe17c401d&cmd_show=1&menu=what_is	Support business analysis through the use of UML modeling notations. Full support for Case Diagrams and Sequence Diagrams. Allows easy extension of business analysis modeling into object oriented application development by using UML.
	Rational Rose	Rational Rose Data Modeler is a visual modeling tool that makes it possible for database designers, analysts, architects, developers and anyone else on your development team to work together, capturing and sharing business requirements, and tracking them as they change throughout the process. http://www-306.ibm.com/software/awdtools/developer/datamodeler/features/	Pioneer in UML modeling Other Rational products: Requisite Pro and XDE Modeler to provide a full suite of capability.
	Rhapsody	Rhapsody is the industry's leading UML 2.0 based Model-Driven Development environment for systems and software engineering, and has the unique ability to extend UML 2.0 to allow both functional oriented and object oriented design techniques to co-exist in one environment. Model-Driven Development (MDD) technology enables you to achieve unparalleled gains in productivity over traditional document driven approaches by enabling you to specify your systems and software design graphically, execute and validate the system as you build it, and ultimately produce full production code from the model for the target system.	Focuses on large-scale systems using UML as the base for all modeling.

MODELING CATEGORY	TOOL NAME	DESCRIPTION	REMARKS
		http://www.ilogix.com/rhapsody/rhapsody.cfm	
	Visual UML	Visual UML® is an affordable, easy-to-use yet powerful and full-featured object modeling tool that provides full and comprehensive support for all of the OMG UML™ (Unified Modeling Language) 1.3 & 1.4 diagram types: Use Case, Package, Class, Object, Activity, State, Collaboration, Sequence, Component, Deployment and Robustness diagrams. http://www.visualobject.com/	A low cost solution to UML modeling.
Business Process Analysis¹⁵			
	Corporate Modeler (Casewise)	Business Process Analysis and Enterprise Architecture, Casewise provides enterprise modeling software and services that enable you to visualize, document and optimize your business processes and systems. http://www.casewise.com/	Gartner says [56]: <i>"Casewise Systems, with Corporate Modeler, has been a traditional leader in the BPA space and is well-known for its inventory of brilliant reports that help clients understand their current process flows. We expect Casewise to move upward as it delivers new releases and partnerships. The other leaders have moved a little more quickly, but Casewise is a quality-minded vendor."</i>
	Enterprise Content Management (ECM) Solutions (FileNet)	FileNet Enterprise Content Management (ECM) solutions are designed to give your company a competitive edge whenever there's a decision to be made. With the combination of content, process and connectivity, our solutions allow customers to build and sustain competitive advantage by managing content throughout their organization, automating and streamlining their business processes, and providing the full-spectrum of connectivity needed to simplify your critical and everyday decision-making.	Gartner says [56] : <i>"FileNet is new to this sector and starts high because of its codevelopment of a code base with CapeVision and the addition of some key personnel. The simulation engine was built natively into a strong BPM suite to support upfront design modeling and in-flight optimization, based on near-real-time data. FileNet is one of the first BPM suites to practice round-trip engineering"</i>

¹⁵ Leaders in Gartner's Magic Quadrant for BPA, 2004 [56].

MODELING CATEGORY	TOOL NAME	DESCRIPTION	REMARKS
		http://www.filenet.com/English/Defining_ECM/index.asp	through its own code base."
	WebSphere® Business Integration (WBI) (IBM)	IBM WebSphere Business Integration Modeler and IBM WebSphere® Business Integration Monitor V4.2.4 improve business visibility for fact-based decision making and more optimized business processes. These products provide a solution to help you model, simulate, analyze, automate, optimize, and monitor business processes quickly and effectively. http://www-306.ibm.com/software/integration/wbimodeler/anncv424/	Gartner says [56]: "IBM has bought Holosofx, which was a visionary in our last BPA Magic Quadrant. This puts IBM squarely in position to evolve WebSphere® Business Integrator (WBI) into a round-trip engineering BPM suite, but this offering is under construction. Although IBM's Rational Rose XDE and WBI modeler offerings are lightly integrated, enterprises can expect deeper integration in the future. IBM will need to reconcile the use of ROSE (Rational) Activity Diagrams and the Rational Unified Process, which is used by some enterprises for business process modeling. We expect slow and steady progress."
	ARIS Design Platform (IDS Scheer)	ARIS Process Platform provides integrated tools for designing, implementing and controlling business processes. Business Process Design is a three-stage process by which companies can tailor their business processes to their own requirements and needs and to those of the market. This element of the continuous improvement cycle comprises the three aspects of design, analysis and optimization. http://www.ids-scheer.com/english/? hitmenu=23254&qoto=/products/productoverview.htm	Gartner says [56]: "IDS Scheer has been a "thought leader" in this sector for years, and it continues its march toward a better round-trip engineering process offering by partnering with SAP for the business process execution platform. In the midterm, IDS Scheer is working with Intalio and Web V2 to offer a solution. IDS Scheer has templates for Six Sigma, the U.S. Public Company Accounting Reform and Investor Protection (Sarbanes-Oxley) Act of 2002 and others."
	MEGASuite (MEGA)	The MEGA Software Environment is supported by MEGA's common repository architecture. This robust, scalable, object-oriented repository fully supports our MEGA consultants and our client design teams ensuring the fullest collaboration and information sharing. Through enterprise	Gartner says [56]: "MEGA is probably the hidden secret in the Leaders quadrant. Its MEGASuite has the most

MODELING CATEGORY	TOOL NAME	DESCRIPTION	REMARKS
		blueprints, business analysts, IT architects and development teams operate in an aligned and highly productive environment. Dedicated MEGA products facilitate a comprehensive and streamlined approach to business process and enterprise architecture design and implementation. http://www.mega.com/en/product/index.asp?l=en	<i>Leaders quadrant. Its MEGASuite has the most powerful and extensible repository in the BPA sector, and it is surrounded by helpful tools and reports for process analysis. Recently, MEGA acquired a code base that supports simulation, and it is aggressively seeking solution partners to move its market activity forward.</i>
	System Architect® (Popkin Software)	System Architect® is a comprehensive and powerful modeling solution designed to provide all of the tools necessary for development of successful enterprise systems. It is the only tool to integrate, in one multi-user product, industry-leading support for all major areas of modeling, including business process modeling, object-oriented and component modeling with UML, relational data modeling, and structured analysis and design. All functionality is harnessed within System Architect®'s extensible repository with native support for Microsoft VBA. System Architect's latest version provides Simulation capabilities. http://www.popkin.com/products/product_overview.htm	Gartner says [56]: <i>"Popkin Software is also a thought leader, and it supports more standards than any other vendor. Its Systems Architect® product, exemplified by its new information-publishing features, has been constantly expanded to support government initiatives, and it has added a stronger simulation capability with its new relationship with Lanner for simulation. Traditionally, Popkin has offered the most function for the money."</i>
	ProVision Workbench (Proforma)	The ProVision modeling suite provides an enterprise-wide process modeling environment that enables companies to quickly know, improve and implement the most cost effective and efficient business processes and systems. ProVision's sharable repository of integrated strategy, process and system models provides the framework to effectively model all dimensions of the enterprise and support initiatives such as process improvement, Six Sigma, ISO certification, enterprise architecture, requirements definition and application development. http://www.proformacorp.com/provision/intro.asp	Gartner says [56]: <i>"Proforma's BPA tool is probably the easiest to use on the market. The ProVision workbench is constantly offering more functionality that appeals to the business users. Proforma offers one of the strongest methodologies in the business, and it has extremely pragmatic consultancy support."</i>
	Visio Professional + Biztalk	Visio functionality enables an organization to quickly document and analyze existing processes providing insight into such areas as:	Gartner says [56]: <i>"Microsoft has edged into leadership with its new</i>

MODELING CATEGORY	TOOL NAME	DESCRIPTION	REMARKS
	(Microsoft)	<ul style="list-style-type: none"> • Resource utilization • Bottlenecks • Costs <p>Process improvements can be easily communicated across the organization using Visio diagrams, ensuring tight coordination.</p> <p>Organizations that use Visio to map and improve their business processes realize measurable benefits including reduced costs and errors, faster time to market for their products and increased worker productivity.</p> <p>http://prade.microsoftemea.com/content/Work Management/Visio BPM 20customer ready v2.ppt</p>	<p>Microsoft Office Visio Professional 2003 linked to a more-powerful Biztalk, which is equipped with a strong rule engine. Although Microsoft owns the premier business process drawing tool, business users often leave the Microsoft suite for other process analysis and execution tools. This is now changing because of partnerships with ProActivity and the new version of Microsoft Office Visio Professional 2003, which can take system-to-system processes forward."</p>
Timelines/ Schedules			
	MS Project	<p>Project managers everywhere rely on Microsoft Office Project Standard to plan and manage their projects. With Microsoft Office Project Standard 2003, you can efficiently organize and track tasks and resources to keep your projects on time and within budget. Extensive help resources and printing assistance make Project Standard 2003 easy to learn, so that you can be productive quickly.</p> <p>http://www.microsoft.com/office/project/prodinfo/standard/overview.mspx</p>	<p>Integrates resources, time and budget into one package for planning and tracking projects.</p>
Task Analysis			
	MS Access	<p>Access 2003 provides a powerful set of tools that are sophisticated enough for professional developers, yet easy to learn for new users. Create or use powerful database solutions that make organizing, accessing, and sharing information easier than ever.</p> <p>http://www.microsoft.com/office/access/prodinfo/overview.mspx</p>	<p>DRDC and Canadian Industry have used custom Designed MS Access databases for many years to conduct Task Analysis. Examples include the CF18 Upgrade and TBMCS (the predecessor to the Land Forces Command and Control Information System).</p>
	Task Architect	<p>TaskArchitect is a task analysis tool designed by Human Factors professionals to make hierarchical task analysis easy. Whether you are using the technique for complex system design or to create</p>	

MODELING CATEGORY	TOOL NAME	DESCRIPTION	REMARKS
		<p>documentation or training materials, TaskArchitect will make your work easier. Some features include:</p> <ul style="list-style-type: none"> • Visually well laid out tasks; • Multiple views of the hierarchy; • Simplicity in editing and moving tasks; • Clear indications of the state of the analysis; • Fast, simple task re-numbering after changes have been made; • Task plan wizard; • Flexibility to support many styles of analysis; and • Simple and expandable, ability to meet particular analytical needs. <p>http://taskarchitect.com/</p>	
	MicroSaint Sharp	<p>Micro Saint Sharp's power, flexibility and tools for optimization make it the simulation tool of choice for any organization. With a computer model of your process built in Micro Saint Sharp, you can begin to get the answers to your "what if" questions. What if I change the way humans work with the system? What if I change my resource mix? What if I rearrange the process? Find the answers with Micro Saint Sharp quickly and completely for systems of all sizes, shapes, and complexities.</p> <p>http://www.maad.com/index.pl/micro_saint</p>	A strong foundation in Human Factors and Military applications.
	IPME	<p>The Integrated Performance Modelling Environment (IPME) is a Unix-based integrated environment of simulation and modeling tools for answering questions about systems that rely on human performance to succeed. IPME provides:</p> <ul style="list-style-type: none"> • A realistic representation of humans in complex environments; • Interoperability with other models and external simulations; and • Enhanced usability through a user friendly graphical user interface. <p>IPME provides a full-featured discrete event simulation environment built on the Micro Saint modeling software. Additionally, it provides added functionality to enhance the modeling of the human component of the system. Finally, it has a number of features that make it easier to integrate IPME models with other simulations on a real-time basis including TCP/IP sockets and tools for developing simulations that adhere to the High Level Architecture (HLA) simulation protocols that are becoming standard throughout the world.</p>	IPME was co-developed with assistance from DERA in the UK and DRDC Toronto in Canada. The tool has been used extensively on DND programs and is the 'standard' for performance prediction modeling.

MODELING CATEGORY	TOOL NAME	DESCRIPTION	REMARKS
		http://www.maad.com/index.pl/ipme	
Cost			
	D4COST	<p>The nation's first choice for reliable cost estimates created from REAL projects is D4COST. D4COST supplies you with a library of actual real projects (buildings) NOT an average. D4COST is the best source to validate any preliminary cost, develop a reliable preliminary or conceptual square foot cost estimate, cost feasibility, valuation study, or budget.</p> <p>http://www.d4cost.com/index.html</p>	Primarily used for building construction projects.
	PRICE	<p>PRICE's Program Affordability Management solutions combine cost estimating, project control, and knowledge management — ensuring project success at every decision gateway.</p> <p>PRICE TrueMethods™: Best practices in Advanced Planning, Bid & Proposal Development, Supplier Selection, Project Cost Management, and Knowledge Management, using proven methods such as Earned Value Management.</p> <p>PRICE TruePlanning™: Proven cost estimating and analysis tools work from building initial estimates to getting costs-to-complete at any point in a project.</p> <p>PRICE Consulting: Experts in Project Cost Control tools and methods implementation for feasibility - delivery program support.</p> <p>http://www.pricesystems.com/solutions/solutions_overview.html</p>	PRICE is a suite of tools. Strong U.S. military focus.
	SEER	<p>From complex software projects to intricate manufacturing processes, Galorath's SEER™ Suite of Tools enable project managers, cost analysts and engineers to make timely, accurate and insightful decisions. SEER tools are powerful, analytical tools that allow you to identify, evaluate and manage the complex array of cost, labor, schedule, reliability and risks associated with an organization's critical projects.</p> <p>Software Project Control</p>	SEER is a suite of tools. Strong U.S. military focus.

MODELING CATEGORY	TOOL NAME	DESCRIPTION	REMARKS
		<p>Software Estimation, Planning and Project Control</p> <p>Hardware Project Control Hardware Estimation, Planning, Project Control and Life-Cycle Cost Analysis, Including Operations and Support</p> <p>Design for Manufacturability Cost Designer for Parts, Process and Assembly</p> <p>http://www.galorath.com/tools_overview.shtml</p>	
	COMET	<p>COMET provides users with Navy manpower cost estimates of active, reserve and civilian components to provide the analyst with a tool to make decisions about manpower or hardware tradeoff comparisons.</p> <p>COMET costs are customizable, allowing you to include only those costs pertinent to your cost analysis.</p> <p>COMET costs are comprehensive, including both the direct costs (MPN) of manning billets and the variable indirect costs (MPN and OMN) associated with acquiring, training, locating and supporting those personnel.</p> <p>COMET costs are granular, varying across skills, pay grade and geographic location (civilians).</p> <p>COMET incorporates parameters from NCCA's Cost of a Sailor (COAS) studies in a PC-based, 32-bit (Windows-95) application that installs on your PC or network in minutes.</p> <p>Users can easily customize specification to a particular cost exercise.</p> <p>Windows-95 environment allows users to easily share data with other applications.</p> <p>Model output can be exported to spreadsheet applications or printed to hard copy.</p>	COMET is produced and maintained by the Naval Cost Analysis Division of the U.S. Navy. It is used on U.S. Navy programs.

MODELING CATEGORY	TOOL NAME	DESCRIPTION	REMARKS
		http://www.ncca.navy.mil/services/comet/index-frame.htm	
<i>Physical</i>			
	AutoCAD	<p>Creating a single drawing as efficiently as possible is important. Delivering an entire set of coordinated drawings is crucial. With AutoCAD® 2005 software you can do both. Productivity features like table objects and enhanced tool palettes simplify drafting tasks and the new Sheet Set Manager helps you create, manage, and share entire sheet sets with maximum efficiency.</p> <p><u>Manage</u> drawing sets more efficiently with tools for controlling, from one location, the content in related drawings.</p> <p><u>Create</u> drawings more quickly with productivity tools that build data tables using a single command, provide instant access to frequently used content, and generate compelling presentations.</p> <p><u>Share</u> data more simply with collaboration tools that enable you to share single drawings or sets of drawings via plots, eTransmit, or DWF™ files.</p> <p>http://usa.autodesk.com/adsk/servlet/index?siteID=123112&id=2704278</p>	CAD – Computer Aided Design. Can be considered an electronic form of drafting.
	MicroStation	<p>MicroStation is Bentley's flagship product for the design, construction and operation of the world's infrastructure. MicroStation and ProjectWise, Bentley's server line for AEC collaboration, form a robust foundation for Bentley's comprehensive portfolio of software solutions.</p> <p>Driven by 10 core technologies, the new release boasts support for Adobe PDF, enhanced DWG interoperability, and digital security. Overall, MicroStation V8 offers AEC organizations new ways to standardize a wide range of processes, such as change management, drafting and drawing, electronic delivery, proposal preparation, and more.</p> <p>http://www.bentley.com/en-US/Products/MicroStation/</p>	AEC – Architecture, Engineering and Construction
	SmartSketch	SmartSketch is an innovative product for the technical office, combining world class business diagramming with award winning drawing	Focus on 2D Drawings.

MODELING CATEGORY	TOOL NAME	DESCRIPTION	REMARKS
		<p>technology. It is a versatile, cost-effective precision engineering and drafting product that gives EPCs and owner/operators a competitive edge throughout the life cycle by speeding productivity, cutting costs, and offering a sophisticated degree of automation for detail work. As an interlocking piece of our best-in-class life cycle solution, SmartSketch is a premium tool for 2D drawing generation. SmartSketch's underlying technology and user interface make it easy to use and integrate with data-centric products, allowing business owners to focus on their primary goals -- increased profitability by lowered costs and higher productivity</p> <p>http://ppo.intergraph.com/smartskech/</p>	

Annexe C: Simulation Tools

Table 9 presents candidate **simulation tools** to support the CEP along with some product examples. Again, the product descriptions provided were extracted from the respective vendor web site. It would therefore be advisable to compare each vendor's product description with independent reviews in order to obtain a more complete and reliable appreciation of each product.

Table 9: Simulation Tools

SIMULATION CLASSES	TOOL NAME	DESCRIPTION	REMARKS
<i>Constructive</i>			
	EXTENT	<p>Extend is designed from the ground up to be a flexible, extendable simulation tool. It can be used to model every aspect of an organization at all levels of expertise - from manager to engineer/scientist and from novice to professional modeler.</p> <p>The goal of Extend is that a modeler will be able to:</p> <ul style="list-style-type: none"> • Build models quickly • Make changes interactively • See results immediately • Explore all alternatives • Develop customized components • Simulate any system or process • Share models and components with others • Use the model as a virtual environment for communicating ideas <p>http://www.imaginethatinc.com/prods_overview.html</p>	
	OpEMCSS	<p>During the last few years, computer simulation has become an essential tool for the design and evaluation of complex systems. Such systems include air and ground transportation networks, military C4ISR multi-agent systems, and complex, international business organizations. These systems are difficult to understand because each agent (subsystem) in the network adapts its behavior in response to knowledge received from other agents. Agents adapting in collaboration with other agents leads to emergent behavior that is much more complex than any agent could achieve alone. Such Complex Adaptive Systems</p>	

SIMULATION CLASSES	TOOL NAME	DESCRIPTION	REMARKS
		<p>(CAS) have the potential of much greater capability and effectiveness than traditional systems if designed properly.</p> <p>A state-of-the-art graphical, discrete event simulation library that works with EXTEND (ImagineThatInc) is available for your evaluation. This library is called Operational Evaluation Modeling for Context-Sensitive Systems (OpEMCSS), and it has the power of much more costly, general-purpose simulation products. OpEMCSS provides the ability to examine important elements in the problem space and to allow the formulation of alternative solution concepts. OpEMCSS facilitates unconventional "out-of-the-box" thinking to discover the underlying system problems and exploit the best alternatives in the solution space without focusing on a point design too soon. In order to simulate various operational scenarios, OpEMCSS includes blocks to model agent motion and spatial interactions, agent communication and knowledge sharing, and intelligent rule-based decision-making.</p> <p>http://jclymer.ecs.fullerton.edu/</p>	
	CORE	<p>The CORE product family provides a flexible combination of modeling and simulation tools supporting product and process engineering. CORE's object-oriented environment delivers the same functionality from a single user workstation to large, distributed, client-server teams. CORE runs under the Microsoft Windows® environment.</p> <p>CORE provides behavioral modeling constructs to identify control flow, function flow, and data flow. Behavioral models (EFFBD) are executable via COREsim, a discrete event simulator. Data links and resources can be modeled to assess communication dynamics, and resource utilization and contention.</p> <p>http://www.vtcorp.com/productline.html</p>	It is one of the suites currently being assessed by DRDC on the CapDEM TDP.
	SIMUL8	<p>SIMUL8 Standard is an integrated environment for working with simulation models. The powerful language and model visualization capabilities enable you to create the accurate, flexible and robust simulations you need in less time.</p> <p>The Benefits:</p> <ul style="list-style-type: none"> • Better control and understanding of resources • Higher quality and efficiency from capital assets • Higher level of customer satisfaction because of better business processes 	

SIMULATION CLASSES	TOOL NAME	DESCRIPTION	REMARKS
		<ul style="list-style-type: none"> • See the impact of relocating equipment or adding resources BEFORE implementation • Do "what if" scenarios before investing time and money • Visually document your process in a way that really captures how it works. <p>http://www.simul8.com/products/s8stand.htm</p>	
	Simulink	<p>Simulink is an interactive tool for modeling, simulating, and analyzing dynamic, multidomain systems. It lets you accurately describe, simulate, evaluate, and refine a system's behavior through standard and custom block libraries. Simulink integrates seamlessly with MATLAB, providing you with immediate access to an extensive range of analysis and design tools.</p> <p>http://www.mathworks.com/products/simulink/</p>	
	MicroSaint Sharp	<p>Micro Saint Sharp is a general purpose, discrete-event simulation software tool. Micro Saint Sharp's intuitive graphical user interface and flow chart approach to modeling make it a tool that can be used by generalists as well as simulation experts. Micro Saint has proven to be an invaluable asset in both small businesses and Fortune 500 companies and in many areas including the military, human factors, health care, manufacturing, and the service industry.</p> <p>http://www.maad.com/index.pl/micro_saint</p>	
	IPME	<p>The Integrated Performance Modelling Environment (IPME) is a Unix-based integrated environment of simulation and modeling tools for answering questions about systems that rely on human performance to succeed. IPME provides:</p> <ul style="list-style-type: none"> • A realistic representation of humans in complex environments • Interoperability with other models and external simulations • Enhanced usability through a user friendly graphical user interface <p>IPME provides a full-featured discrete event simulation environment built on the Micro Saint modeling software. Additionally, it provides added functionality to enhance the modeling of the human component of the system. Finally, it has a number of features that make it easier to integrate IPME models with other simulations on a real-time basis including TCP/IP sockets and tools for developing simulations that adhere to the High Level Architecture (HLA) simulation protocols that are becoming standard throughout the world.</p>	

SIMULATION CLASSES	TOOL NAME	DESCRIPTION	REMARKS
		http://www.maad.com/index.pl/ipme	
	Corporate Modeler (Casewise)	Corporate Modeler's simulator automatically generates statistical analysis so users can monitor the effect of change on throughput times, resource utilization and costs. It offers a complete range of advanced simulation tools - including Simulator, Grapher, Analyzer, and Financial. These products run in parallel with simulations and provide higher-level, in-depth analyses for users, which aid in achieving process flow optimization. http://www.casewise.com/products/corporate-modeler/simulation.php	
	Enterprise Content Management (ECM) Solutions (FileNet)	Process Simulator allows you to create and run simulation scenarios that can be analyze using the Simulation Animator application and Process Analyzer. http://www.filenet.com/English/Products/Datasheets/023250025.pdf	FileNet website does not expand much in describing Process Simulator.
	WebSphere® Business Integration (WBI) (IBM)	IBM WebSphere® Business Integration Modeler provides easy-to-use tools to help model, simulate, monitor and analyze business processes to be automated by IBM MQSeries Workflow. http://www-306.ibm.com/software/integration/wbimodeler/anncv424/	IBM website does not expand much in describing Integration Modeler.
	ARIS Design Platform (IDS Scheer)	ARIS Simulation is the professional tool for the dynamic analysis of business processes. Since ARIS Simulation is fully integrated in the ARIS Toolset™ you can use the data relating to the processes, recorded in the ARIS Toolset, as a basis for the simulation of business processes. This simulation supplies information about the executability of processes, process weak points and resource bottlenecks. Based on the simulated process key performance indicators, you can evaluate different alternatives and perform a realistic benchmarking prior to making any cost-intensive process changes within the company. Simulation capabilities allow: <ul style="list-style-type: none">• Removal of bottlenecks• Evaluation of process variants• Reduction of throughput times• Capacity planning	

SIMULATION CLASSES	TOOL NAME	DESCRIPTION	REMARKS
		<ul style="list-style-type: none"> • Optimization of resource utilization • Cost reduction. <p>http://www.ids-scheer.com/english/? hitmenu=23254&goto=/products/productoverview.htm</p>	
	MEGASuite (MEGA)	<p>MEGA Process includes a new, advanced simulation tool to assist in business process management and organization optimization. It integrates all the elements required for simulation of the business processes concerned. In particular, new concepts have been implemented to handle all aspects of simulation.</p> <p>Models concerned with simulation are:</p> <ul style="list-style-type: none"> • Business process: business process diagram; • Procedure: flowchart; • Activity: business process diagram; and • Workflow: workflow diagram. <p>Simulation capabilities provided include:</p> <ul style="list-style-type: none"> • Time evaluation; • Resource and Cost evaluation; • Memorized hypothesis and dynamic hypothesis results; and • Dynamic link with Microsoft Excel. <p>http://www.mega.com/en/product/mega_process/index.asp?l=en&p=simulation</p>	
	SA Simulator II™ (Popkin Software)	<p>SA Simulator II™ enables you to perform simulation on hierarchies of process models. Using this technique, business analysts typically build simple high-level business process diagrams, and decompose processes with connected 'child' diagrams that show more process flow details. Business analysts continue to decompose processes in this manner, so that at any level the process flow presented is easy to understand.</p> <p>http://www.popkin.com/products/system_architect/simulator.htm</p>	
	ProVision Workbench	<p>ProVision AnalyzerPlus lets you define unique business case scenarios, and perform process simulation and animation with cost, timing and resource analysis for all your workflow models. Each process can contain multiple processing scenarios, allowing an unlimited number of "what if" analyses.</p>	

SIMULATION CLASSES	TOOL NAME	DESCRIPTION	REMARKS
	(Proforma)	<p>Different "what if" analysis can be performed by varying resource allocation, commodity inventories and replenishment levels.</p> <p>AnalyzerPlus' main capabilities include:</p> <ul style="list-style-type: none"> • Scenario Based Simulation –Simulate scenarios to see how the process will behave under specific conditions. • Resource Constraints and Bottleneck Identification –Vary resource requirements and constraints to analyze potential bottlenecks within each process scenario. • Critical Path Analysis – Visualize the paths through the process scenario that incur the least/most cost and take the least/most time to execute. • Activity Base Costing (ABC) – Identify all direct, indirect and resource costs associated with an activity. • Resource Planning – Helps identify the specific number of resources required to perform processes efficiently. • Scenario Comparison – Compare the results of all process simulations. This is a straightforward way to see the most cost effective and efficient processes. • Animation – Visually observe the process running, or run lengthy processes in the background. The data from the simulation is then available for investigation using the analysis and reporting features. • Analysis and Reporting – Display and analyze—with the push of a button—simulation results in the form of cost and timing spreadsheets and graphs. • Opportunity Analysis – Identify and assign opportunities and their costs and benefits to the activities where process improvement prospects exist. <p>http://www.proformacorp.com/provision/analyzerplus.asp</p>	
	Visio Professional + Biztalk (Microsoft)	<p>SIMUL8 Corporation and Microsoft Corporation have worked together to closely integrate VISIO and SIMUL8. SIMUL8 Corporation offers a powerful 'what if' animation and analysis tool, giving users the ability to see their business with a new perspective, all within a familiar Visio environment.</p> <p>http://www.simul8.com/products/visio.htm</p>	<p>SIMUL8 can import from other BPA tools:</p> <ul style="list-style-type: none"> • ARIS Tool Set (IDScheer); • MooD (The Salamander Organization); • ProActivity; • Popkin; • Process Navigator (Triaster); • SigmaFlow; and • iGrafx Flowcharter (Corel/Micrografx).
Virtual			

SIMULATION CLASSES	TOOL NAME	DESCRIPTION	REMARKS
	ITEMS	<p>CAE's Interactive Tactical Environment Management System (ITEMS™) is a proven software product for creating sophisticated and complex tactical environments for air, land, and sea applications. The product has been used extensively to provide high-fidelity computer-generated forces and electronic warfare environments. With its physics-based engineering-level models, ITEMS provides unparalleled realism in its representation of weapons, sensors, and platforms.</p> <p>ITEMS excels in real-time, human-in-the-loop simulations such as those required for full mission training and crew station research and development. ITEMS has been used for a broad range of applications, including:</p> <ul style="list-style-type: none"> • Anti-submarine warfare training and doctrine development; • Anti-surface warfare training; • Tactical and attack helicopter training and mission rehearsal; • Air-air and air-ground combat training with intelligent interactive air targets and synthetic wingmen; • Maritime and air surveillance training; • Reconnaissance vehicle and tank crew training; • Survivability experiments; • Digitization of the battlefield experiments; • UAV studies; and • Officer cadet education and training. <p>http://www.cae.ca/en/military/modeling/support_ITEMS.shtml</p>	<p>Used in Canadian Full Flight Simulators such as the CH146 Griffon simulator in Gagetown. Provides the full Synthetic Tactical Environment and Computer Generated Forces for conducting tactical missions.</p>
	ModSAF	<p>ModSAF, or Modular Semi-Automated Forces, is the successor to the SIMNET and ODIN Semi-Automated Forces systems. It provides an open, modular architecture that DIS and CGF researchers can build upon and extend. It contains no proprietary components and runs on a variety of UNIX platforms. It provides uniform methodology and software support for creating and controlling entities on a simulated battlefield. These entities replicate the outward behaviour of their component vehicle and weapon systems to a level of realism sufficient for training and combat development. ModSAF-simulated entities can behave autonomously; that is, they can move, fire, sense, communicate, and react without operator intervention. These entities can interact with each other as well as manned simulators, over a network supported by ADS.</p> <p>Currently, ModSAF performs many functions that are useful to modeling and simulation (M&S) users in all three domains: Advanced Concepts and Requirements (ACR); Research, Development and Acquisition (RDA); and</p>	<p>ModSAF is used by the Army Experimentation Center in Kingston, ON. The AEC is also a OneSAF Testbed.</p> <p>ModSAF is also used within DRDC. It has been used extensively on the Defensive Aids Suite for the LAV at DRDC Valcartier.</p>

SIMULATION CLASSES	TOOL NAME	DESCRIPTION	REMARKS
		<p>Training, Exercises and Military Operations (TEMO).</p> <p>http://www.peostri.army.mil/DRSTRICOM/SOFTWARE/SUMMARIES/modsaf_sum.html</p>	
	DISAF	<p>DISAF was developed to add dismounted infantry to the virtual battlefield in a realistic fashion. Before DISAF, the infantry capabilities of simulations such as SIMNET and ModSAF had essentially been limited to the low-fidelity viewpoint of tanks, i.e., a difficult-to-see anti-tank threat. The Dismounted Warrior Network (DWN) project, a delivery order under the Advanced Distributed Simulation Technology II (ADST II) program, sought to improve the fidelity of infantry simulation so that exercises emphasizing infantry could be meaningfully developed. In particular, experimental "Virtual Individual Combatant" (VIC) simulators were constructed using existing technology, and DISAF capabilities were developed from a ModSAF baseline. The goal of DWN was to develop infantry simulation capabilities that could support acquisition, analysis, and training activities.</p> <p>In the first phase of the DWN project, DISAF was developed from a Marine Corps ModSAF variant that supported Individual Combatant (IC) based units in rural (open) terrain. The second phase of DWN added Enhancements for Restricted Terrain (ERT), i.e., operations in urban terrain. In the second phase experiments of DWN, DISAF demonstrated its ability to simulate fire teams of ICs blowing a hole in a building, entering the building through the hole, moving inside the building to clear rooms, and engaging threats inside the building.</p> <p>http://www.asset.com/disaf/disaf_home.htm</p>	<p>"Development work, thus far, has built upon the foundation of a number of existing virtual simulation systems which have been integrated into an interoperable network of individual soldier simulators and simulations."</p> <p>Although not using DISAF directly, DRDC Toronto has conducted Dismounted Soldier Simulation as part of the Soldier Information Requirements (SIREQ) TDP.</p>
	JOINTSAF	<p>JointSAF stands for Joint Semi-Automated Forces. Some people use the term Synthetic Forces (SF), but we prefer Semi-Automated Forces to emphasize the human component. Joint Semi-Automated Forces (JointSAF) 3.2 is a large software system that generates entity level militarily significant platforms, interactions, and behaviours in a robust Synthetic Natural Environment. In other words, all interactions are resolved at the individual platform level, whether that is an infantryman, a tank, a ship, or an airplane. The individual entities are task organized into appropriate units for a given mission. One of the unique things about STOW is the sophisticated interaction with the environment, so that a particular interaction can be effected by line of sight, time of day, and weather.</p> <p>JointSAF consists of four major components: ArmySAF (similar to ModSAF 4.0</p>	<p>"Although JointSAF and ModSAF have a similar heritage, there are some major differences. ModSAF is an Army simulation managed by STRICOM. JointSAF is a Joint simulation developed and managed by DARPA. There is a close working relationship between DARPA and STRICOM and the two simulations develop synergistically. ModSAF has better documentation than JointSAF and a much larger user community. ModSAF is controlled by the Army and what goes into a ModSAF release is controlled by a Configuration Control Board that</p>

SIMULATION CLASSES	TOOL NAME	DESCRIPTION	REMARKS
		<p>released by STRICOM in May 98), NavySAF, Marine Corps SAF, and AirSAF. A realistic South West Asia OPFOR is available which contains non-combatants including individuals, commercial shipping, and commercial aircraft. UK specific entities were built for the ACTD using the JointSAF framework, but they are not currently supported. All of the SAF software that was developed for the Joint Counter Mine Operational Simulation (JCOS) has been incorporated into the JointSAF baseline. A complete listing of the entities that are currently simulated can be found in the STOW SAFMaster database on the STOW web site. TacAir Soar is an advanced artificial intelligence system which is an integral part of JointSAF and provides highly automated and sophisticated fixed wing pilot behaviours. TacAir Soar is one of the largest real-time "expert" systems ever developed. Operators can use both Soar air and SAF air together in an exercise. An Exercise Editor and an AWOC (Automated Wing Operations Center) are also available to assist in setting up Air missions.</p> <p>http://stow98.spawar.navy.mil/</p>	<p>consists of representatives from the three Army domains: ACR, RDA, and TEMO. Much of the documentation developed for ModSAF applies to JointSAF as well."</p>
	OneSAF	<p>OneSAF will be a composable, next generation computer generated forces (CGF) that can represent a full range of operations, systems, and control process from individual combatant and platform to battalion level, with a variable level of fidelity that supports all modeling and simulation (M&S) domains. It will accurately and effectively represent specific activities of ground warfare (engagement and manoeuvre), Command, Control, Communications, Computers, and Intelligence (C4I), combat support, and combat service support. It will also employ appropriate representations of the physical environment and its effect on simulated activities and behaviours.</p> <p>http://www.onesaf.org/public1saf.html</p>	<p>"The need for OneSAF capabilities is not a response to a specific warfighting threat against the force: the need is driven by the guidance to reduce duplication of M&S investments, foster interoperability and reuse across M&S domains, and meet M&S requirements of the future force." – Mission Needs Statement of OneSAF</p> <p>The Canadian Army Experimentation Center in Kingston is a OneSAF test bed.</p>
	STAGE	<p>STAGE is a unique portfolio of Commercial-off-the-shelf (COTS) simulation products that are open, re-configurable, flexible and extendible. Together, these products provide a backbone to build more complex and complete training systems, avionics test benches, mission planning and rehearsal systems in an integrated or distributed DIS or HLA environment.</p> <p>The STAGE family provides an ideal combination of products for creating simulators designed to carry out studies in new tactics and equipment, and is well suited for any training system where a realistic outside world environment is required.</p>	<p>STAGE is used at various installations within DND. It was used as the Synthetic Tactical Environment on the TAMSS TDP and is also used by the Air Force Experimentation/Simulation Center in Winnipeg.</p>

SIMULATION CLASSES	TOOL NAME	DESCRIPTION	REMARKS
		<p>Stage is perfect for designing simulations for the following applications:</p> <ul style="list-style-type: none"> • Weapons control systems; • Crew Navigation and weapons trainers; • Armored vehicle gunnery; • Command & Control; • Naval combat systems; • Part-task simulators; • Cockpit and flight procedure trainers; and • Avionics test bench. <p>STAGE Scenario is a Commercial-off-the-shelf (COTS) software tool used to build and animate in real-time synthetic environments containing both moving and stationary entities such as airplanes, ships, land vehicles, missiles, radar sites, etc. that interact with one another as a function of pre-determined rule sets, or through operator intervention during execution of the simulation.</p> <p>http://www.engenuitytech.com/products/STAGE/index.shtml</p>	
	STRIVE	<p>CAE's Synthetic Tactical Real-time Interactive Virtual Environment (STRIVE™) is really two packages - STRIVE™ SFX (STRIVE Framework Suite) is a commercial off-the-shelf simulation development environment and STRIVE™ CGF is a high fidelity, full function synthetic tactical environment and computer generated forces package. STRIVE SFX helps significantly shorten development cycles by allowing developers to focus on building models without the concern for how the models communicate, interact, and perform in real-time. Also, STRIVE SFX reduces new development through the use of existing libraries of full-fidelity, physics-based models as well as software wrappers to reuse and integrate legacy models. With its libraries of models and graphical user interface, STRIVE CGF can be used "out-of-the-box" as a full function CGF application.</p> <p>http://www.cae.ca/en/military/modeling/support_STRIVE.shtml</p>	STRIVE is being used throughout DRDC on various R&D initiatives including the UAV Research Test Bed at the Future Force Synthetic Environment.
	OneTESS	<p>A family of Tactical Engagement Simulation systems that support Force-on-Force (FOF) and Force-on-Target (FOT) training exercises at Brigade and below, in all Battlefield Operating Systems at Homestation, maneuver Combat Training Centers, and deployed sites.</p> <p>The system will require execution of proper engagement procedures; will simulate weapon system's accuracy and effects; and stimulate detectors, sensors, monitors and countermeasures.</p>	

SIMULATION CLASSES	TOOL NAME	DESCRIPTION	REMARKS
		<p>OneTESS will use a common architecture compliant with the Common Training Instrumentation Architecture (CTIA).</p> <p>The OneTESS family of simulators will provide these capabilities:</p> <ul style="list-style-type: none"> • Electronic warfare (EW) and Information Operations Warfare (IOW); • Engineer warfare and countermines; • Nuclear, biological, and chemical (NBC); • Ground-to-ground engagements (includes directly and indirectly fired munitions); • Ground-to-air engagements; • Air-to-air and air-to-ground engagements; • Smart fire-and-forget engagements; • Countermeasures (CM) and Counter-countermeasures (CCM); and • Non-lethal munitions. <p>http://www.peostri.army.mil/PRODUCTS/ONETESS/</p>	
	Supressor	<p>Suppressor is a US Air Force, event-stepped, mission-level simulation widely used by government and industry as a powerful tool for operational concept evaluation and electronic combat analysis. It conducts Measure of Effectiveness (MOE) and Cost and Operational Effectiveness Analyses (COEA) in evaluating different weapon systems, sensor systems, tactics, or command procedures in composite missions against an integrated air defense. Suppressor allows users to define, at various levels of detail, the types of military systems to be modeled and the way those systems may interact. Suppressor simulates human behavior, sensors (infrared, electro-optical, radar, and radar warning receiver), radios, jammers, movement systems, and weapon systems.</p> <p>http://www.sisostds.org/webletter/siso/liss_73/art_327.htm</p>	
	CFOR	<p>Army Ground Command Forces (CFOR) employs an artificial intelligence methodology known as "Constraint Satisfaction Problem-Solving" to model the command and control decision making of several Army ground unit commanders. An Army Mechanized Company Team Commander, a Fire Support Team (FIST), and a Battalion Task Force Commander are available. A CFOR Command and Control Workstation (C2WS) is available to assist in setting up exercises. This program has been extended under the ASTT program and now contains a brigade level movement to contact operation.</p>	

SIMULATION CLASSES	TOOL NAME	DESCRIPTION	REMARKS
		http://stow98.spawar.navy.mil/ http://ms.ie.org/cfor/cfor.html	
	WARSIM	<p>WARSIM 2000 is a computer based simulation with associated hardware and is the Army's next generation command and control training environment. In conjunction with JSIMS, it will support the training of unit headquarters and command posts from battalion through theater-level in joint and combined scenarios. Additionally, it will provide command post training events in educational institutions. It will be designed to allow units worldwide to train in their command posts using organic C4I equipment, with a minimum of overhead. This simulation system will meet emerging distributed simulation standards and protocols, thus providing a comprehensive joint environment capable of linking its simulation based constructive entities with virtual (simulator based) and instrumented vehicles.</p> <p>http://www.peostri.army.mil/PRODUCTS/WARSIM/</p>	<p>WARSIM 2000 will replace, in priority order, a number of existing legacy training simulations including Corps Battle Simulation (CBS), Tactical Intelligence Simulation (TACSIM), and the Combat Service Support Training Simulation System (CSSTSS).</p>
	JSIMS	<p>JSIMS supports training and education of ready forces by providing realistic joint training across all phases of military operations for all types of missions. JSIMS provides for Joint training as well as Service specific training. A distributed, constructive wargaming simulation, JSIMS is designed to create a single, seamlessly integrated Joint Synthetic Battlespace (JSB(1)) to provide a common environmental and operational picture of the battlespace. It will interface with the command, control, communications, computers, and intelligence (C4I) functions and equipment in the field, thus providing the interface between the JSB and the training audience. The resulting effect is a training environment indistinguishable by the training audience and the real world.</p> <p>http://www.jsims.mil/about.html</p>	
	JANUS	<p>Janus is a low-cost, flexible, interactive, event-driven, ground combat simulation. It is effective for battle-focused training from platoon to battalion level and for limited command and battle staff training at battalion level.</p> <p>Janus offers a fully automated After Action Review (AAR) capability that can track and replay the battle just as it developed; that can provide analytical</p>	

SIMULATION CLASSES	TOOL NAME	DESCRIPTION	REMARKS
		<p>information such as losses, direct fire, artillery, obstacles, etc.; and that can provide graphical comparisons between enemy and friendly forces. The AAR capability provides the user the capability to analyze a battlefield event down to a single combat system.</p> <p>The purpose of Janus is to model the battlefield as closely as possible. It puts "thinking" players on both sides of the battlefield. Using a simple Janus menu, they fight the battle. Recent enhancements of Janus provide greater capability for engineer play and for better training opportunities for commanders and staff at battalion and below.</p> <p>While all simulations have limitations, Janus provides as realistic a model of the battlefield at battalion and below as can be found in Model & Simulation world. Training scenarios can be quickly developed and new combat systems can be added to the database. The user interface is simple and user-friendly and training personnel to operate the workstations is not lengthy. Janus can be used as a tactics trainer, combat leader trainer, operational rehearsal tool, historical analysis tool, disaster relief exercise driver or provide limited staff training in conjunctions with tactics of leader training.</p> <p>http://www.riley.army.mil/view/article.asp?id=181-2002-05-15-31569-28</p>	
<i>Live</i>			
	AWES	<p>Area Weapons Effect Simulator (AWES) is the world's most advanced ground combat training package in operation today, providing effective combined arms training for the British Army. The land-based system is now operational at two locations: the Salisbury Plain Training Area in the UK and at the British Army Training Unit at Suffield, Alberta, Canada.</p> <p>AWES, with fully integrated Tactical Engagement Simulation (TES), provides unprecedented fidelity and realism for simulated force-on-force battles and objective After Action Reviews (AARs).</p> <p>The system features timely and realistic area weapons effects simulation, new soldier and vehicle instrumentation systems and a software-based system for exercise planning, mission control and AARs. AWES integrates portions of the British Army's existing Direct Fire Weapons Engagement System with Cubic's</p>	The system is currently being installed in Canada at Wainwright and Gagetown.

SIMULATION CLASSES	TOOL NAME	DESCRIPTION	REMARKS
		<p>Multiple Integrated Laser Engagement System (MILES 2000).</p> <p>AWES simulates artillery, mortar fire, smoke, nuclear, biological, chemical attacks, mines and air-delivered munitions during the simulated battles. Participants in the training exercises are equipped with digital communications that indicate their position, weapons fired and casualty status.</p> <p>The system electronically captures and records event data from individual soldiers and vehicles and sends the information to an exercise control center for real-time training analysis. The recorded information is reviewed during AARs, which are conducted in either a stationary theater or two mobile theaters in the field.</p> <p>The integration of the new Bowman radio communication system will bring full digitization into the TES environment. AWES is designed to support future interoperability with the Helicopter Collective Training System and the Rangeless Airborne Instrumented Debriefing System.</p> <p>Major Features:</p> <ul style="list-style-type: none"> • Simulates indirect fire, minefields, obstacles and air-delivered munitions; • Integrates MILES 2000 and the existing DFWES to enable participants equipped with both systems to operate as a cohesive unit; • Features an instrumentation system that monitors exercises in near-real time and provides event data for AARs; • Includes a universal player unit (instrumentation issued to all vehicles and soldiers) to provide flexibility and adaptability to a diverse training population; • Features innovative audio cues for area weapons effects that enhance the use of pyrotechnics; • Supports combined arms training; • Features virtually transparent equipment for the participants to minimize distraction; • Utilizes Cubic's proven data link technology using VHF frequencies • Produces realistic notional casualties through automated electronic casualty cards, enabling effective training in casualty treatment and evacuation; • Provides the ability to monitor and record Combat Net Radio across the Instrumented Battlefield; to be expanded to support Bowman digital radio capabilities; and 	

SIMULATION CLASSES	TOOL NAME	DESCRIPTION	REMARKS
		<ul style="list-style-type: none"> <li data-bbox="746 337 1400 415">Includes a seamless interface with the British Army's Battlefield Artillery Target Engagement System (BATES) to allow for fully integrated indirect fire simulation and battlefield effects. <p data-bbox="697 428 1464 483">http://www.cubic.com/cda1/Prod & Serv/Cmbt Trng Sys/Grnd Cmbt Trng/AWES.html</p>	

Annexe D: M&S Tools and CEP activities

The following table summarizes the M&S tool usage within the activities of the preliminary CEP definition¹⁶.

Table 10: Mapping of M&S Tools on the CEP Activities

		Establish the Current Situation										Develop a Capability Vision				Develop an Architecture					Establish the Transformation Roadmap							
		Organizational Structure	Activities Performed by Each Element	Information Exchanged Among the Participating Organizations	Resources Required	Functional Decomposition	Function Allocation	Platforms/Facility Physical Model	System Physical Model	Operational Personnel & Manning	Measures of Effectiveness Definition	Technology Assessment	Doctrine & Tactics Development	Force Structure Development	Documentation	Identification of Architecture Alternatives	Feasibility Assessment of Alternative Architectures	Alternative Operational Model Development	Alternative Functional Model Development	Alternative Physical Model Development	Evaluate Cost/Effectiveness	Document the Vision Architecture	Organizational Evolution Assessment	Capability Evolution Assessment	Force Training & Transition Planning	Establish the Investment Plan		
Modelling																												
	Organizational	Team Flow	X	X	X	X				X			X	X											X			
		MS OrgChart	X										X	X											X			
		OrgPlus	X	X		X				X			X	X			X							X				
		MS Visio	X	X	X	X							X	X			X	X						X				
	Business Process	AllFusion Process Modeler		X	X		X						X	X		X		X	X		X	X		X				
		CORE	X	X	X	X	X	X	X	X	X	X	X	X	X	X	X	X	X	X	X	X	X	X	X	X	X	
		WorkFlow Modeler		X	X		X						X	X		X		X	X		X	X		X				
		MagicDraw	X	X	X	X		X	X				X	X		X	X	X	X	X	X		X		X			
		Rational Rose	X	X	X	X		X	X				X	X		X	X	X	X	X	X		X		X			
		Rhapsody	X	X	X	X		X	X				X	X		X	X	X	X	X	X		X		X			

¹⁶ At the writing of this report, it was not possible to analyze each product individually. This product mapping is completed to the best of our knowledge.

		Establish the Current Situation										Develop a Capability Vision				Develop an Architecture				Establish the Transformation Roadmap						
		Organizational Structure	Activities Performed by Each Element	Information Exchanged Among the Participating Organizations	Resources Required	Functional Decomposition	Function Allocation	Platforms/Facility Physical Model	System Physical Model	Operational Personnel & Manning	Measures of Effectiveness Definition	Technology Assessment	Doctrine & Tactics Development	Force Structure Development	Documentation	Identification of Architecture Alternatives	Feasibility Assessment of Alternative Architectures	Alternative Operational Model Development	Alternative Functional Model Development	Alternative Physical Model Development	Evaluate Cost / Effectiveness	Document the Vision Architecture	Organizational Evolution Assessment	Capability Evolution Assessment	Force Training & Transition Planning	Establish the Investment Plan
	Visual UML	X	X	X	X			X	X						X	X	X	X	X	X	X	X				
BPA CASE Tool	Corporate Modeler	X	X	X	X	X	X			X	X				X	X	X	X	X	X	X	X	X	X	X	X
	Enterprise Content Manager	X	X	X	X	X	X			X	X				X	X	X	X	X	X	X	X	X	X	X	X
	Websphere® Business Integration	X	X	X	X	X	X			X	X				X	X	X	X	X	X	X	X	X	X	X	X
	ARIS Design Platform	X	X	X	X	X	X			X	X				X	X	X	X	X	X	X	X	X	X	X	X
	MEGASuite	X	X	X	X	X	X			X	X				X	X	X	X	X	X	X	X	X	X	X	X
	System Architect®	X	X	X	X	X	X			X	X				X	X	X	X	X	X	X	X	X	X	X	X
	ProVision Workbench	X	X	X	X	X	X			X	X				X	X	X	X	X	X	X	X	X	X	X	X
	Visio Professional + Biztalk	X	X	X	X	X	X			X	X				X	X	X	X	X	X	X	X	X	X	X	X
Timelines & Schedules	MS Project		X		X					X					X						X	X				X
Task Analysis	MS Access		X	X		X	X																			
	Task Architect		X	X		X	X																			
	MicroSaint Sharp		X	X	X	X				X	X		X			X	X	X			X		X	X	X	
	IPME		X	X	X	X	X			X	X		X			X	X	X					X	X	X	
Cost	D4COST																				X					
	PRICE																				X					
	SEER				X					X				X							X					

		Establish the Current Situation								Develop a Capability Vision				Develop an Architecture				Establish the Transformation Roadmap								
		Organizational Structure	Activities Performed by Each Element	Information Exchanged Among the Participating Organizations	Resources Required	Functional Decomposition	Function Allocation	Platforms/Facility Physical Model	System Physical Model	Operational Personnel & Manning	Measures of Effectiveness Definition	Technology Assessment	Doctrine & Tactics Development	Force Structure Development	Documentation	Identification of Architecture Alternatives	Feasibility Assessment of Alternative Architectures	Alternative Operational Model Development	Alternative Functional Model Development	Alternative Physical Model Development	Evaluate Cost / Effectiveness	Document the Vision Architecture	Organizational Evolution Assessment	Capability Evolution Assessment	Force Training & Transition Planning	Establish the Investment Plan
	COMET	X							X											X						
Physical	AutoCAD						X	X					X	X			X	X	X		X					
	MicroStation						X	X					X	X			X	X	X		X					
	SmartSketch						X	X					X	X			X	X	X		X					
Simulation																										
Constructive	SIMUL8	X	X	X			X	X		X					X		X	X	X		X					
	Simulink						X	X		X	X					X		X	X							
	MicroSaint Sharp		X	X	X	X			X	X	X					X	X	X		X		X	X	X		
	IPME		X	X	X	X			X	X	X					X	X	X				X	X	X		
	Suppressor							X		X		X	X			X	X			X						
(BPA)	Corporate Modeler	X	X	X	X				X	X				X		X	X	X		X	X	X	X	X	X	
	Enterprise Content Manager	X	X	X	X				X	X				X		X	X	X		X	X	X	X	X	X	
	Websphere® Business Integration	X	X	X	X				X	X				X		X	X	X		X	X	X	X	X	X	
	ARIS Design Platform	X	X	X	X				X	X				X		X	X	X		X	X	X	X	X	X	
	MEGASuite	X	X	X	X				X	X				X		X	X	X		X	X	X	X	X	X	
	System Architect®	X	X	X	X				X	X				X		X	X	X		X	X	X	X	X	X	
	ProVision Workbench		X	X	X				X	X				X		X	X	X		X	X	X	X	X	X	
	Visio Professional +	X	X	X	X				X	X				X		X	X	X		X	X	X	X	X	X	

		Establish the Current Situation										Develop a Capability Vision				Develop an Architecture				Establish the Transformation Roadmap						
		Organizational Structure	Activities Performed by Each Element	Information Exchanged Among the Participating Organizations	Resources Required	Functional Decomposition	Function Allocation	Platforms/Facility Physical Model	System Physical Model	Operational Personnel & Manning	Measures of Effectiveness Definition	Technology Assessment	Doctrine & Tactics Development	Force Structure Development	Documentation	Identification of Architecture Alternatives	Feasibility Assessment of Alternative Architectures	Alternative Operational Model Development	Alternative Functional Model Development	Alternative Physical Model Development	Evaluate Cost/Effectiveness	Document the Vision Architecture	Organizational Evolution Assessment	Capability Evolution Assessment	Force Training & Transition Planning	Establish the Investment Plan
	Biztalk																									
Virtual	ITEMS	X	X	X	X			X	X	X	X	X	X	X	X	X	X	X	X	X			X	X		
	ModSAF	X	X	X	X			X	X	X	X	X	X	X		X	X	X	X	X			X	X		
	DISAF	X	X	X	X					X	X		X	X		X	X						X	X		
	JOINTSAF	X	X	X	X			X	X	X	X	X	X	X		X	X	X	X	X			X	X		
	OneSAF	X	X	X	X			X	X	X	X	X	X	X		X	X	X	X	X			X	X	X	
	STAGE	X	X	X	X			X	X	X	X	X	X	X		X	X	X	X	X			X	X		
	STRIVE	X	X	X	X			X	X	X	X	X	X	X		X	X	X	X	X			X	X		
	OneTESS	X	X	X	X			X	X	X	X	X	X	X		X	X	X	X	X			X	X		
	CFOR	X	X	X				X		X		X	X	X		X	X	X					X	X		
	WARSIM	X	X	X	X			X	X	X	X	X	X	X		X	X	X	X	X			X	X	X	
	JSIMS	X	X	X	X			X	X	X	X	X	X	X		X	X	X	X	X			X	X	X	
	JANUS	X	X	X	X			X	X	X	X	X	X	X		X	X	X	X	X			X	X	X	
Live	WES	X	X	X	X			X	X	X	X	X	X	X		X	X	X	X	X			X	X	X	

List of symbols/abbreviations/acronyms/initialisms

3D	Three Dimensions
ABS	Acquisition basée sur la simulation
AoA	Analysis of Alternatives
CASE	Computer-Aided System Engineering
CapDEM TPD	Collaborative Capability Definition Engineering and Management Technology Demonstrator Program
CD&E	Concept Development and Experimentation
CE	Capability Engineering
CEE	Collaborative Engineering Environment
CEP	Capability Engineering Process
CF	Canadian Force
CM	Configuration Management
COEA	Cost and Operational Effectiveness Analysis
DIF	Date Interchange Format
DIGCap	Définition, ingénierie et gestion collaboratives des capacités
DIS	Distributed Interactive Simulation
DMS	Defence Management System
DND	Department of National Defence
DPD	Distributed Product Development – Description de produit distribuée
DP&M	Defence Planning and Management
FC	Forces canadiennes
FOC	Final Operational Capability

HW/SWIL	Hardware/Software In the Loop
IC	Ingénierie des capacités
ILS	Integrated Logistics and Support
IOC	Initial Operational Capability
IPPD	Integrated Product and Process Development
IPT	Integrated Project Team
IS	Ingénierie de systèmes
JCRB	Joint Capability Review Board
L1CP	Level One Capital Plan
LCMS	Lide Cycle Management and Support
LORA	Level Of Repair Analysis
LSA	Logistics Support Analysis
LTCP	Long Term Capital Plan
M&S	Modeling and Simulation / Modélisation et Simulation
MDN	Ministère de la Défence nationale
MOE	Measures Of Effectiveness
MOO	Measures Of Outcome
MOP	Measures Of Performance
MR&P	Mission Rehearsal & Planning
MSRR	Modeling and Simulation Resource Repository
P,O&M	Production, Operation and Maintenance
PIC	Processus d'ingénierie des capacités
PIP	Project Implementation Plan
PMB	Program Management Board

PPRA	Project Profile and Risk Assessment
R&D	Research and Development
SBA	Simulation Based Acquisition
SdS	Systeme de systemes
SE	Synthetic Environment
SOR	Statement of Operational Requirements
SOTA	State-Of-The-Art
SoS	Systems of systems
SoSE	System of systems Engineering
SRB	Senior Review Board
SS(ID)	Synopsis Sheet Identification
SS(EPA)	Synopsis Sheet Effective Project Approval
SS(PPA)	Synopsis Sheet Preliminary Project Approval
STEP	Simulation, Test and Evaluation Process
SysEng	Systems Engineering
T&E	Test and Experimentation
TCO	Total Cost of Ownership
TEMP	Test and Evaluation Master Plan
VR	Virtual Reality

Distribution List

INTERNAL DISTRIBUTION

2 - Document Library

1 - F. Bernier

1 - M. Couture

1 - G. Dussault

1 - C. Lalancette

1 - M. Lizotte

1 - M. Mokhtari

EXTERNAL DISTRIBUTION

1 - DRDKIM

SANS CLASSIFICATION
COTE DE SÉCURITÉ DE LA FORMULE
(plus haut niveau du titre, du résumé ou des mots-clefs)

FICHE DE CONTRÔLE DU DOCUMENT		
1. PROVENANCE (le nom et l'adresse) CGI	2. COTE DE SÉCURITÉ (y compris les notices d'avertissement, s'il y a lieu) Sans classification	
3. TITRE (Indiquer la cote de sécurité au moyen de l'abréviation (S, C, R ou U) mise entre parenthèses, immédiatement après le titre.) CapDEM TD - Modelling and Simulation (Role and Tools) State of the Art Report		
4. AUTEURS (Nom de famille, prénom et initiales. Indiquer les grades militaires, ex.: Bleau, Maj. Louis E.) Mike Wellwood (The HFE Group) et Claude Drouin (CGI) Autorité Scientifique - François Bernier et Marielle Mokhtari		
5. DATE DE PUBLICATION DU DOCUMENT (mois et année) 2005	6a. NOMBRE DE PAGES 115	6b. NOMBRE DE REFERENCES 56
7. DESCRIPTION DU DOCUMENT (La catégorie du document, par exemple rapport, note technique ou memorandum. Indiquer les dates lorsque le rapport couvre une période définie.) Rapport de contrat		
8. PARRAIN (le nom et l'adresse)		
9a. NUMÉRO DU PROJET OU DE LA SUBVENTION (Spécifier si c'est un projet ou une subvention) 15as (Numéro de projet)	9b. NUMÉRO DE CONTRAT W7701-3-2621	
10a. NUMÉRO DU DOCUMENT DE L'ORGANISME EXPÉDITEUR	10b. AUTRES NUMÉROS DU DOCUMENT N/A	
11. ACCÈS AU DOCUMENT (Toutes les restrictions concernant une diffusion plus ample du document, autres que celles inhérentes à la cote de sécurité.) <input checked="" type="checkbox"/> Diffusion illimitée <input type="checkbox"/> Diffusion limitée aux entrepreneurs des pays suivants (spécifier) <input type="checkbox"/> Diffusion limitée aux entrepreneurs canadiens (avec une justification) <input type="checkbox"/> Diffusion limitée aux organismes gouvernementaux (avec une justification) <input type="checkbox"/> Diffusion limitée aux ministères de la Défense <input type="checkbox"/> Autres		
12. ANNONCE DU DOCUMENT (Toutes les restrictions à l'annonce bibliographique de ce document. Cela correspond, en principe, aux données d'accès au document (11). Lorsqu'une diffusion supplémentaire (à d'autres organismes que ceux précisés à la case 11) est possible, on pourra élargir le cercle de diffusion de l'annonce.)		

SANS CLASSIFICATION
COTE DE LA SÉCURITÉ DE LA FORMULE
(plus haut niveau du titre, du résumé ou des mots-clefs)

SANS CLASSIFICATION
COTE DE LA SÉCURITÉ DE LA FORMULE
(plus haut niveau du titre, du résumé ou des mots-clefs)

13. SOMMAIRE (Un résumé clair et concis du document. Les renseignements peuvent aussi figurer ailleurs dans le document. Il est souhaitable que le sommaire des documents classifiés soit non classifié. Il faut inscrire au commencement de chaque paragraphe du sommaire la cote de sécurité applicable aux renseignements qui s'y trouvent, à moins que le document lui-même soit non classifié. Se servir des lettres suivantes: (S), (C), (R) ou (U). Il n'est pas nécessaire de fournir ici des sommaires dans les deux langues officielles à moins que le document soit bilingue.)

Ce rapport fournit une revue de l'état de l'art sur le rôle de la modélisation et simulation (M&S) dans le contexte du processus d'ingénierie des capacités (PIC) tel que défini jusqu'à présent dans le cadre de l'initiative DIGCap. Le rapport présente brièvement les lignes directrices préliminaires suggérées par le PIC à l'endroit du processus d'acquisition en vigueur au MDN/FC, et décrit comment celui-ci devrait permettre d'appuyer efficacement, une fois son élaboration complétée, les concepts d'acquisition basés sur la simulation (ABS) dans un environnement collaboratif d'ingénierie des capacités (IC). Les concepts fondamentaux de la M&S sont ensuite présentés ainsi que son application dans le cadre du processus d'acquisition de capacités dans le domaine militaire. Subséquemment, le rapport décrit comment la M&S peut être mise à profit lors des principales étapes du PIC et présente à l'égard de ce dernier certains outils de modélisation et de simulation pouvant être envisagés. Le rapport conclut en identifiant des zones d'opportunité susceptibles d'aider l'initiative DIGCap dans la poursuite de ses travaux, à mieux définir le rôle de la M&S à l'égard du PIC.

14. MOTS-CLÉS, DESCRIPTEURS OU RENSEIGNEMENTS SPÉCIAUX (Expressions ou mots significatifs du point de vue technique, qui caractérisent un document et peuvent aider à le cataloguer. Il faut choisir des termes qui n'exigent pas de cote de sécurité. Des renseignements tels que le modèle de l'équipement, la marque de fabrique, le nom de code du projet militaire, la situation géographique, peuvent servir de mots-clés. Si possible, on doit choisir des mots-clés d'un thésaurus, par exemple le "Thesaurus of Engineering and Scientific Terms (TESTS)". Nommer ce thésaurus. Si l'on ne peut pas trouver de termes non classifiés, il faut indiquer la classification de chaque terme comme on le fait avec le titre.)

Acquisition Process
Capability
Capability Engineering
Capability Engineering Process
CapDEM
Modellisation and Simulation

SANS CLASSIFICATION
COTE DE SÉCURITÉ DE LA FORMULE
(plus haut niveau du titre, du résumé ou des mots-clefs)

523368
CA625674