

PRODUCTION AND DOSIMETRIC EVALUATION OF AN ION BEAM AT THE AURORA FACILITY

D. C. Judy, G. Merkel, J. C. Blackburn, R. M. Fleetwood
 Army Research Laboratory, 2800 Powder Mill Rd., Adelphi, MD 20783-1197

D. M. Weidenheimer, S. G. Gorbics, N. R. Pereira, P. Y. Cho
 Berkeley Research Associates, P. O. Box 852, Springfield, VA 22151

N. A. Guardala, J. L. Price
 Naval Surface Warfare Center, White Oak, MD 20903

Abstract

A large fluence of ions (protons) was produced by using a single arm of the Aurora in a reversed polarity from its typical operation (4-5 MeV, 8k Joules). A spatially and temporally homogeneous proton current density was produced over more than 300 cm². Electrons emitted from a tubular cathode impinged on a 2-mil polyethylene foil producing the protons, whose depth-dose deposition could be controlled by the A-K spacing. A variety of measurement techniques; (1) electromagnetic, (2) radiachromic-depth-dose, (3) diamond PCD, (4) calorimetric, and (5) proton time-of-flight were used to verify these results. These techniques are described and the results discussed and compared.

I. INTRODUCTION

One of the goals of the work described in this paper was to produce and verify a well-defined, spatially and temporally homogeneous distribution of proton current density over a large area. Such a proton beam having significant depth of penetration into a number of materials can be used to excite mechanical responses in various structures without melting the surface. In order to achieve this goal, we needed to develop adequate proton-beam measurement techniques. This paper describes comparisons between the various proton-beam-parameter measuring techniques examined in this study.

II. EXPERIMENTAL TEST BED

A single arm of the Aurora was excited in a reversed polarity. A part of this experimental arrangement is shown in figure 1. Figure 2 shows the output of a Magic particle-in-cell (PIC)¹ calculation of the electron beam and proton beam

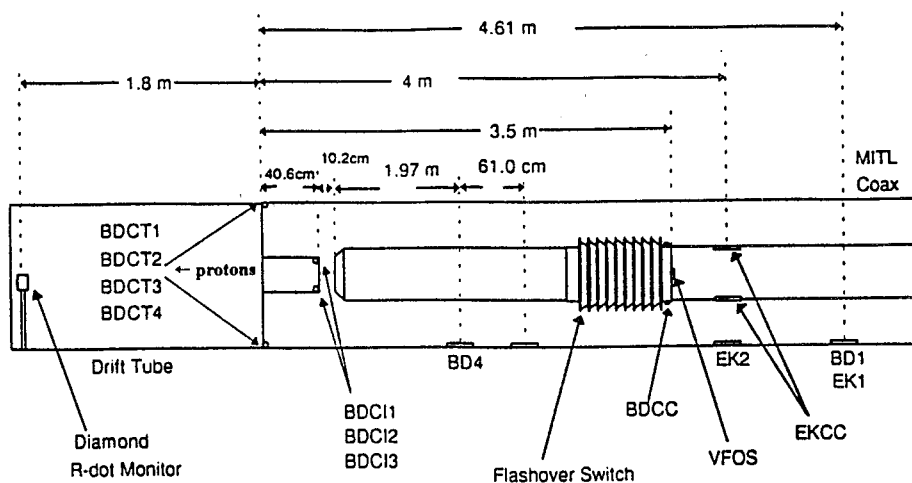

Figure 1. Diagram of experimental setup (not to scale) (Direction of protons ←). Arrows point to the sensors. The B-dot sensors are designated by the first letter B. The sensors BCD11, BCD12, and BCD13 measure ion current. Other B sensors measure total current. The sensors marked with the first letter E are E-dot sensors. The sensor marked "VFOS" measures the flash-over switch voltage drop.

Report Documentation Page

Form Approved
OMB No. 0704-0188

Public reporting burden for the collection of information is estimated to average 1 hour per response, including the time for reviewing instructions, searching existing data sources, gathering and maintaining the data needed, and completing and reviewing the collection of information. Send comments regarding this burden estimate or any other aspect of this collection of information, including suggestions for reducing this burden, to Washington Headquarters Services, Directorate for Information Operations and Reports, 1215 Jefferson Davis Highway, Suite 1204, Arlington VA 22202-4302. Respondents should be aware that notwithstanding any other provision of law, no person shall be subject to a penalty for failing to comply with a collection of information if it does not display a currently valid OMB control number.

1. REPORT DATE JUL 1995	2. REPORT TYPE N/A	3. DATES COVERED -			
4. TITLE AND SUBTITLE Production And Dosimetric Evaluation Of An Ion Beam At The Aurora Facility		5a. CONTRACT NUMBER			
		5b. GRANT NUMBER			
		5c. PROGRAM ELEMENT NUMBER			
6. AUTHOR(S)		5d. PROJECT NUMBER			
		5e. TASK NUMBER			
		5f. WORK UNIT NUMBER			
7. PERFORMING ORGANIZATION NAME(S) AND ADDRESS(ES) Army Research Laboratory, 2800 Powder Mill Rd., Adelphi, MD 20783-1197		8. PERFORMING ORGANIZATION REPORT NUMBER			
9. SPONSORING/MONITORING AGENCY NAME(S) AND ADDRESS(ES)		10. SPONSOR/MONITOR'S ACRONYM(S)			
		11. SPONSOR/MONITOR'S REPORT NUMBER(S)			
12. DISTRIBUTION/AVAILABILITY STATEMENT Approved for public release, distribution unlimited					
13. SUPPLEMENTARY NOTES See also ADM002371. 2013 IEEE Pulsed Power Conference, Digest of Technical Papers 1976-2013, and Abstracts of the 2013 IEEE International Conference on Plasma Science. Held in San Francisco, CA on 16-21 June 2013. U.S. Government or Federal Purpose Rights License.					
14. ABSTRACT A large fluence of ions (protons) was produced by using a single arm of the Aurora in a reversed polarity from its typical operation (4-5 MeV, 8k Joules). A spatially and temporally homogeneous proton current density was produced over more than 300 cm². Electrons emitted from a tubular cathode impinged on a 2-mm polyethylene foil producing the protons, whose depth-dose deposition could be controlled by the A-K spacing. A variety of measurement techniques; (1) electromagnetic, (2) radiachromic-depth-dose, (3) diamond PCD, (4) calorimetric, and (5) proton time-of-flight were used to verify these results. These techniques are described and the results discussed and compared.					
15. SUBJECT TERMS					
16. SECURITY CLASSIFICATION OF:			17. LIMITATION OF ABSTRACT SAR	18. NUMBER OF PAGES 6	19a. NAME OF RESPONSIBLE PERSON
a. REPORT unclassified	b. ABSTRACT unclassified	c. THIS PAGE unclassified			

during an Aurora discharge. These calculations provide a general understanding of the production of the ion beam, although they have been refined to be more than qualitative. Figure 2 depicts relativistic electrons, emitted from the tubular cathode, impinging on the 2-mil polyethylene foil and ionizing the foil to produce protons. The slow-moving non-relativistic protons then accelerate in the opposite longitudinal direction and enter a drift tube where the radiachromic measurements are obtained.

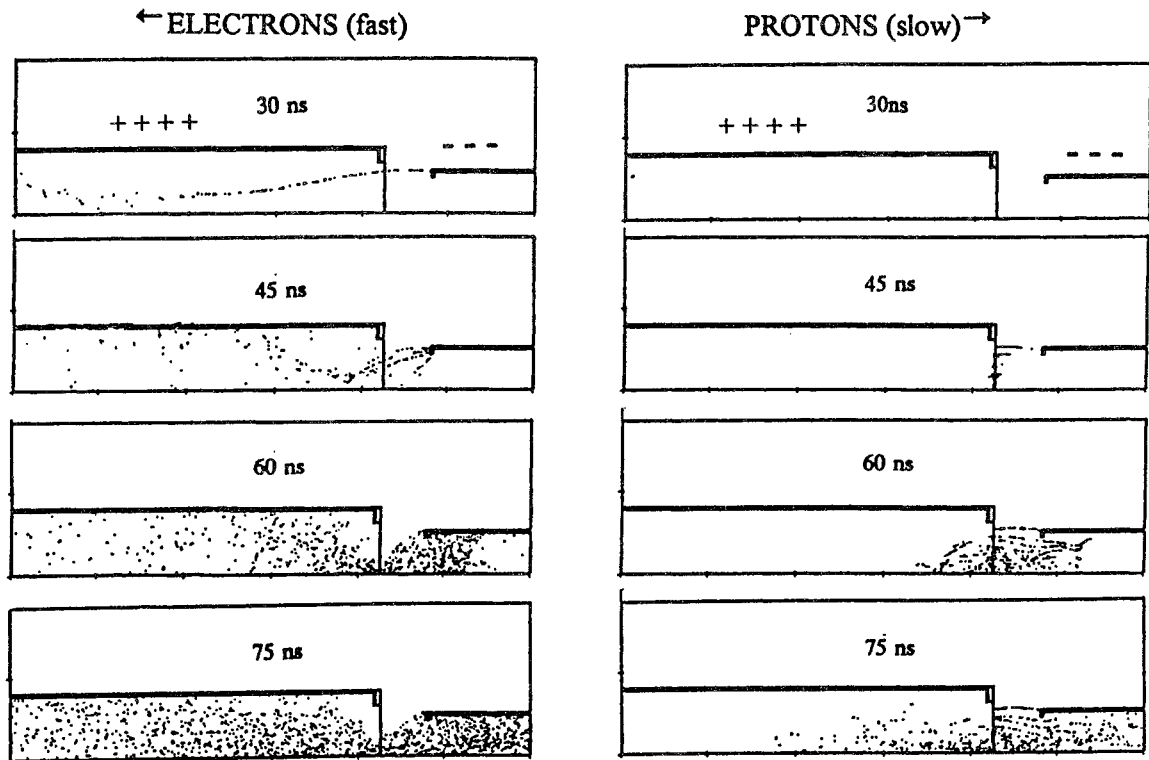

Figure 2. MAGIC particle-in-cell calculation of electron and proton swarms during a typical Aurora shot for diode configuration shown in Figure 1. (Direction of protons \rightarrow).

III. ELECTROMAGNETIC AND DOSE-RATE MEASUREMENTS

In figure 1, the positions of a number of B-dot probes and capacitive electric-field probes are shown. The positions of the B-dot probes are marked with the letter combination BD and those of the electric field probes by the letters EK. The probe marked VFOS was calibrated to yield the voltage drop across the flash-over switch. Measurements with these probes can be interpreted to yield the electric field and currents at the diode. Figure 3a shows diode voltage and current; figure 3b shows diode voltage and ion current; figure 3c shows ion power and energy; and figure 3d shows total diode power and energy. This ion power measurement is consistent to within 5% with a radiachromic film mapping of the total energy deposited in the drift tube chamber.

IV. RADIACHROMIC STACKED FOIL MEASUREMENTS

Radiachromic-proton dosimetry measurements³ on the depth-dose profile of the proton beam were made using a stack of aluminum foils sandwiched between radiachromic nylon films. The dose in the film is determined from the change in optical density, OD, measured at two wavelengths, i.e. 6000 and 5100Å⁰. Far West Technology, Inc., of Goleta, CA, provided very thin (approximately 1 mg/cm² or 10µm) radiachromic films that allowed up to 15 foils/films in a sandwich stack (figure 4).

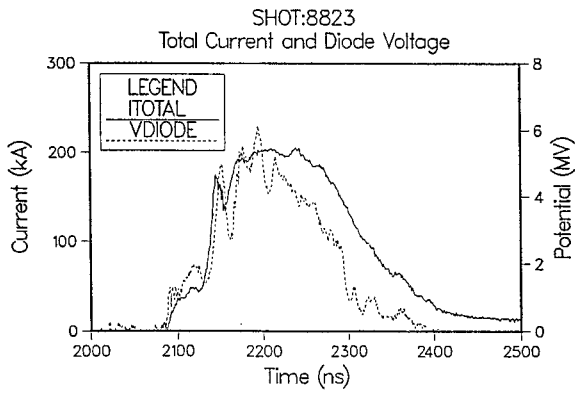

Figure 3a. Diode voltage and current.

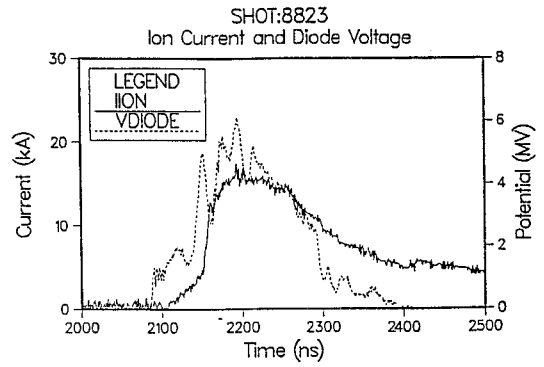

Figure 3b. Diode voltage and ion current

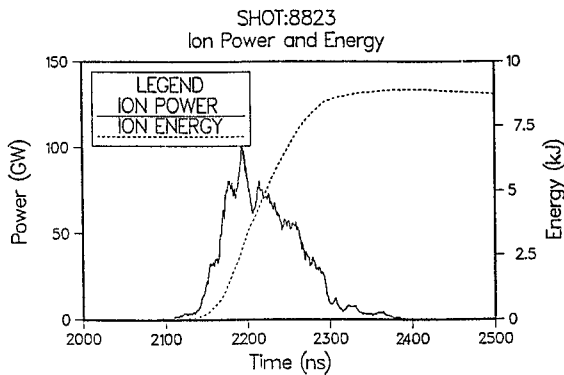

Figure 3c. Ion power and energy

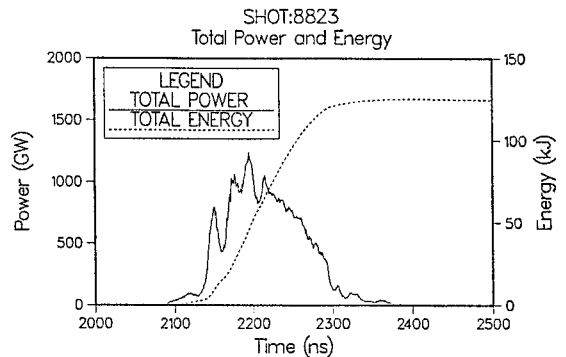

Figure 3d. Total diode power and energy.

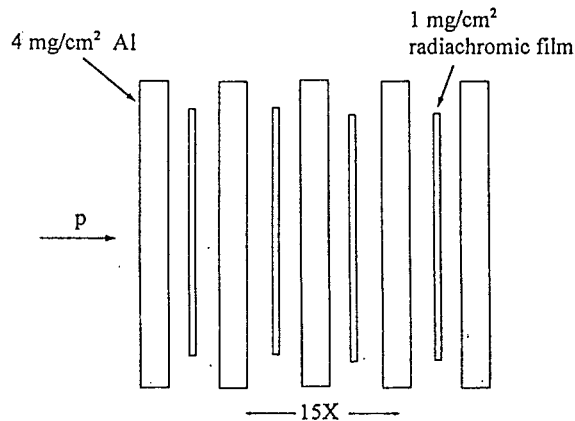

Figure 4. Stacked foil dosimetry sandwich. The first foil could be Al or a radiachromic film.

Figure 5 shows calibration points obtained with Co^{60} gamma rays and protons produced by the NSWC Pelletron. The Pelletron data corresponds to 2- and 4-MeV protons. Bombardment with He ions on another radiachromic film batch resulted in similar agreement. Agreement between the Co^{60} and Pelletron data is within 20 percent. The calibration supplied by the manufacturer, (F.W.T.), corresponding to a different film batch, is substantially different.

That the radiachromic films could be saturated (which must be avoided for accurate measurements) was demonstrated by bombarding a 1 mg/cm^2 radiachromic film with 8 MeV silicon ions at the NSWC Pelletron. A 19.1 Mrad bombardment yielded a radiachromic film change in optical density that corresponded to 1.13 Mrads, a value that was a factor of 8.92 below the actual value. A similar 9.54 Mrad bombardment yielded a ratio of 8.44. This error is explainable by the fact that the stopping power of protons and silicon ions is very different. The maximum stopping power of protons in Al is about $0.476\text{ MeV}/(\text{gm}/\text{cm}^2)$ at 65 KeV. At 8 MeV the stopping power of silicon ions in Al is $11.1\text{ MeV}/(\text{gm}/\text{cm}^2)$, and at 4MeV the stopping power of silicon is $8.68\text{ MeV}/(\text{gm}/\text{cm}^2)$.

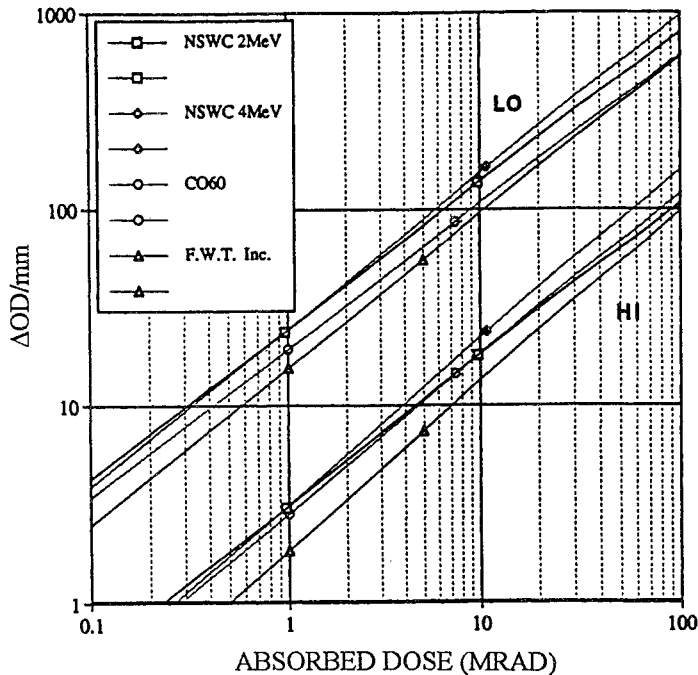

Figure 5. Radiachromic film calibration curves. The curve marked LO (low dose) corresponds to 600 nm wave length absorption, the curve marked HI (high dose) corresponds to 510 nm wave length absorption.

The symbols in the figure are defined as follows:

- --NSWC Ion Source Calib. (2MeV)
- ◇ --NSWC Ion Source Calib (4MeV)
- -- Co^{60} Calibration
- △ --Far West Technology Inc. Calib. Curve

$\Delta\text{OD}/\text{mm}$ corresponds to the change in optical density divided by foil thickness in mm.

V. INTERPRETATION OF STACKED FOIL DOSIMETRY MEASUREMENTS

Three Aurora proton-beam depth-dose profile measurements obtained with stacked foils are shown in figure 6. The 2" AK gap results in a lower diode impedance than the 5" AK gap. A high impedance diode has a higher voltage across it and therefore accelerates the protons to a higher energy. High energy protons produce a deeper dose-depth profile.

The stacked-foil measurements of the ion beam can be interpreted by "unfolding" or "peeling" ^{4,5} to yield the energy distribution of the proton-beam density as a function of proton-beam energy. Figure 7 shows the calculated relative response of stacked-foil, aluminum- radiachromic-foil sandwiches for various proton energies, and figure 8 shows a three Aurora proton-beam energy distributions derived from measurements of the type shown in figure 6, interpreted via figure 7. The different energy distributions in figure 8 correspond to the various anode-cathode gaps in figure 1.

VI. DIAMOND DETECTOR

In figure 9 the power-waveform-pulse shape of figure 3d, derived from electric field and magnetic field (current) measurements is, compared with a dose-rate measurement obtained with a diamond photo-conducting detector ² positioned as shown in figure 1. The two-pulse shape measurements shown in figure 9 can be combined with time-of-flight techniques to estimate the proton energy distribution. Note that the risetime of the beam, measured by the diamond detector, is decreased by time-of-flight pulse compression; the low energy (slow) ions produced at the beginning of the pulse are overtaken by the faster-moving ones produced later in the pulse.

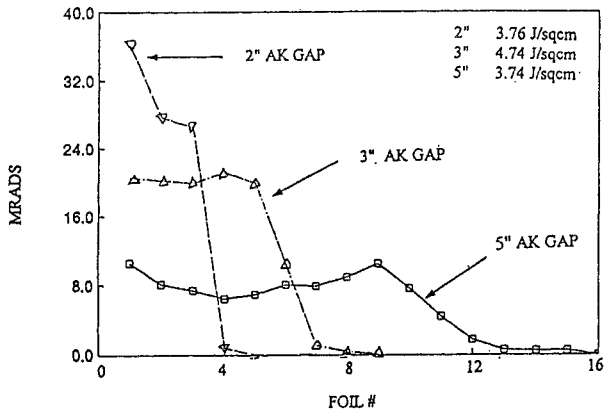

Figure 6. Foil depth-dose plots obtained for 3 different AK settings.

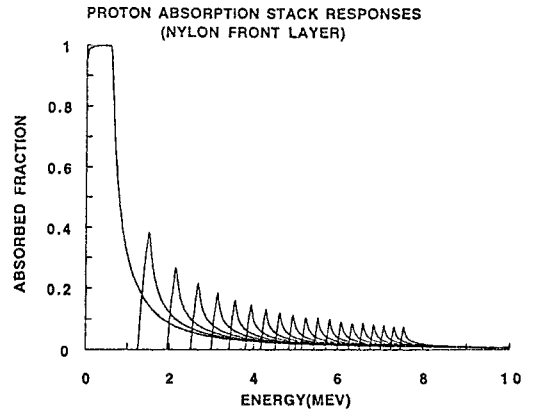

Figure 7. Relative response of radiochromic films in 15 foil absorption stack sandwich.

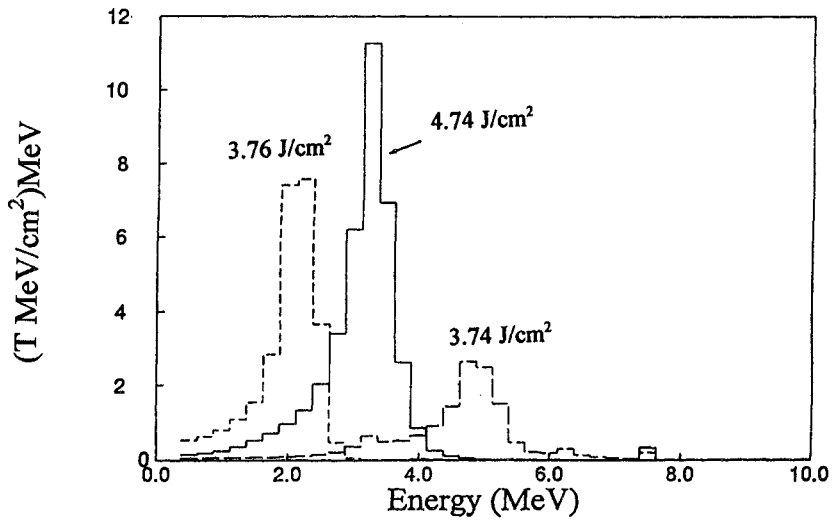

Figure 8. Three examples of unfolded spectra.

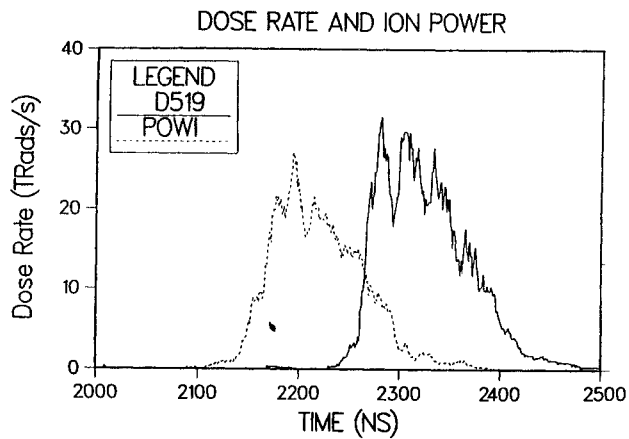

Figure 9. Comparison of electromagnetic power measurement (POW1) and diamond detector (D519).

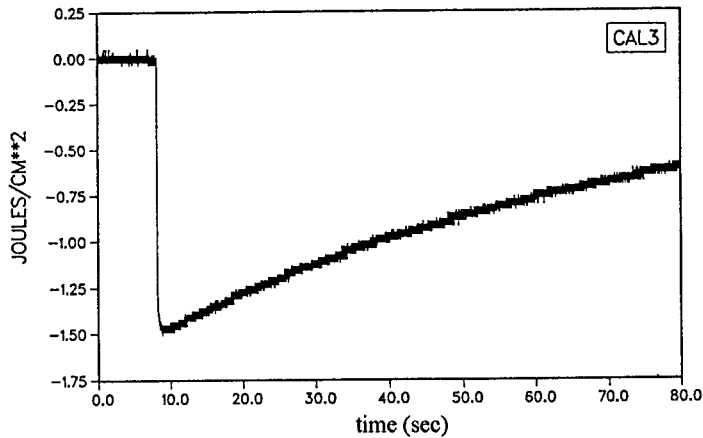

Figure 10. Calorimeter measurement curve. The decay corresponds to cooling of foil after Aurora shot.

TABLE I

SHOT #	AK Gap	calorimeter J/sq cm	Film on calorimeter	Ratio
9019	4"	1.280	1.790	1.398
9020	4"	1.740	2.400	1.379
9021	4"	0.840	0.808	0.962
9022	4"	2.130	3.590	1.685
9023	4"	1.600	1.760	1.100
9024	4"	0.888	1.040	1.172
9025	4"	0.815	0.717	0.879
9026	3"	0.524	0.659	1.258
9027	3"	0.840	0.742	0.883
9028	3"	1.260	1.240	0.984
		ave	1.170	
		std dev	0.260	

References:

1. B. Goplin, L. Ludeking, J. McDonald, G. Warren, and R. Worl, "Magic User's Manual," Mission Research Corp. Report MRC/WDC-R-184 (1988).
2. R. S. Wagner, J. R. Joseph, R. A. Hilko, R. W. Harper, J. R. Tinsley, "The Temporal Response and Relative Proton-To-Gamma Ratio of Radiation Detectors Made From Natural Diamond," draft of talk presented at November 1992 Conference, "Application of Accelerators in Research and Industry," Denton, TX.
3. F. C. Young, J. R. Boller, and S. J. Stephanakis, "Radiachromic Film as a Fluence Diagnostic for Intense Pulsed Proton Beams," June 7, 1994, IEEE International Conference on Plasma Science, Santa Fe, NM and also W. L. McLaughlin, In *Manual on Radiation "Radiochromic dye-cyanide dosimeters,"* edited by N. W. Holm and R. J. Berry (New York:Marcel Dekker), p. 377.
4. For a general discussion of unfolding, see I. J. D. Craig and J. C. Brown, *Inverse Problems in Astronomy* (Hilge, Bristol, 1986), Widely used unfolding codes based on matrix methods include STAY'SL (F. G. Perey, ORNL/TM-6062, 1977), and LSL (F. W. Stallman, NUREG/CR-0029, 1983). These codes are available from the Radiation Shielding Information Center, ORNL.
5. S. G. Gorbics and N. R. Pereira, "Differential absorption spectrometer for pulsed bremsstrahlung," *Rev. Sci. Instrum.* **64**(7), p. 1835, July 1993.

VII. CALORIMETRY MEASUREMENTS

Figure 10 shows an oscilloscope trace corresponding to a typical calorimeter measurement. The decay of the curve in this figure corresponds to the temperature loss of the tantalum calorimeter foil as a function of time. Table I compares a number of stacked-foil energy measurements with calorimetry measurements obtained adjacent to the stacked foil.

VIII. CONCLUSIONS

The dose-depth profiles produced by the ion beam were controlled by changing the AK gap. Radiachromic dose-depth measurements were within ± 20 percent of the electromagnetic and calorimetry measurements; giving confidence in the measurements. In general, stacked-foil measurements can be used to obtain dose-depth distributions as a function of position. The films can, however, be saturated. For example, the response of a radiachromic film to a 8-MeV silicon ion indicated a dose that was lower than the actual dose by a factor of 8.92. It is necessary to make sure that the radiachromic film is not being saturated.