

# THE EFFECTS OF CRYOGENIC INITIAL TEMPERATURES ON ALUMINUM AND COPPER ELECTRICALLY EXPLODED FOIL FUSES

JERRY C. BUECK, R. E. REINOVSKY  
AIR FORCE WEAPONS LABORATORY

## ABSTRACT

The characteristics of electrically exploded foil fuses operated with no parallel load under varying temperature and heat transfer conditions are investigated. A 60 KJ 60 KV capacitive energy storage system operated at 39 KJ is used to vaporize aluminum and copper fuses which are surrounded by small room temperature glass beads, glass beads cooled to approximately 80K, room temperature deionized water and liquid nitrogen. Different granular quenches with substantially differing coefficients of heat transfer are also tested with aluminum fuses. Initial fuse temperature is seen to have a significant effect on fuse performance as predicted in computational simulations with aluminum being more affected than copper.<sup>5</sup>

## INTRODUCTION

Electrically exploded foil fuses have been used as current interruptors in high energy storage systems for several years at the Air Force Weapons Laboratory (AFWL). They have effectively interrupted megamps of current and held off several hundred kilovolts in transferring energy from inductive stores to loads of a mixed inductive and dissipative impedance used in a variety of plasma physics experiments.<sup>3</sup> The study of the details of the physics of the behavior of electrically exploded foil fuses has been an ongoing process at the Weapons Lab for several years.<sup>1,2,4</sup> This study constitutes an extension of that effort to improve fuse performance and expand the knowledge of fuse physics.

Effective energy transfer from the SHIVA-STAR capacitive energy system to a typical plasma physics experiment requires that fuse opening switches meet several criteria simultaneously. In order to effectively charge the intermediate inductive store, the fuse must display minimum initial resistance. In order to effectively drive a useful load, the fuse must display the highest possible resistance upon vaporization. Increased resistance on opening can be obtained by increasing the resistivity of the fuse at vaporization, by decreasing the cross-section of the fuse, by increasing the fuse length or by a combination of these. The cross-section of the fuse determines the time of current interruption and the length of the fuse is chosen to obtain maximum energy transfer to the particular experimental load.<sup>5,7</sup> The vapor state resistivity appears relatively insensitive to most experimental parameters, therefore reducing the cross-section and increasing the length of the fuse while maintaining interruption near the current peak, will result in maximum energy storage in the inductance.

One way to allow reduction of the fuse cross-section and increase its length while maintaining the same opening time is to reduce the initial resistivity of the fuse (while presumably maintaining its late time

vapor resistivity unchanged). Such a reduction in early time resistivity can be obtained by significantly reducing the initial fuse temperature substantially below room temperature especially with metals such as aluminum which display large resistivity changes at liquid nitrogen temperatures. The potential for cryogenic fuses performance is limited by the fact that not only does resistivity decrease but heat capacity decreases as reduced temperatures. Another way to achieve lower early time resistivity is to remove energy from the fuse metal early in time thereby limiting the buildup of internal energy during the time before opening and keep the fuse resistivity lower for a longer period of time. The first method of reducing the cross-section of the fuse can be implemented by immersing the fuse in cryogenic material. The second method can be achieved by placing the fuse in contact with a quench material with high thermal conductivity, heat capacity and density. Computer simulations have shown that increased heat flow by increasing  $\sqrt{k\rho c}$  (See Table 1) results in an improvement in fuse performance .5

This paper describes the results of a series of experiments designed to investigate the actual effect of reduced initial fuse temperatures and improved heat transfer to the quench medium. Both aluminum and copper fuses are tested and compared. Several different quenches are used to investigate the effect of thermal transfer. The experiments indicate that improved fuse performance is indeed possible.

## THE EXPERIMENT

A 36 microfarad capacitive energy storage system charged to 45KV with a 300 nh inductive energy store was used for testing the foil fuses. Figure 1 shows the equivalent circuit. This system LC time constant was chosen to be similar to that of the SHIVA-STAR in hopes that the results obtained on the small system can be directly applied to the large system.<sup>6</sup> The fuses were all two element fuses of a design indicated in Figure 2. Figure 2 also shows the fuse mounting method as well as the envelope containing the various granular quenches tested.

Current and voltage data were obtained using Rogowski coils and a capacitive V-dot probe located as indicated in Figure 1. The signals were recorded on a set of transient digitizers. Typical voltage and current waveforms are indicated in Figure 3. In addition I-dot signals were recorded directly and used when needed in the data analysis in preference to numerically differentiating the passively integrated current data. Calibration of the voltage and current data was accomplished using bank short circuit shots and a circuit model. Known parameters of system capacitance, charge voltage and system inductance were used with measured data to determine self consistent scalefactor

## Report Documentation Page

*Form Approved*  
*OMB No. 0704-0188*

Public reporting burden for the collection of information is estimated to average 1 hour per response, including the time for reviewing instructions, searching existing data sources, gathering and maintaining the data needed, and completing and reviewing the collection of information. Send comments regarding this burden estimate or any other aspect of this collection of information, including suggestions for reducing this burden, to Washington Headquarters Services, Directorate for Information Operations and Reports, 1215 Jefferson Davis Highway, Suite 1204, Arlington VA 22202-4302. Respondents should be aware that notwithstanding any other provision of law, no person shall be subject to a penalty for failing to comply with a collection of information if it does not display a currently valid OMB control number.

1. REPORT DATE <b>JUN 1983</b>	2. REPORT TYPE <b>N/A</b>	3. DATES COVERED <b>-</b>	
4. TITLE AND SUBTITLE <b>The Effects Of Cryogenic Initial Temperatures On Aluminum And Copper Electrically Exploded Foil Fuses</b>		5a. CONTRACT NUMBER	
		5b. GRANT NUMBER	
		5c. PROGRAM ELEMENT NUMBER	
6. AUTHOR(S)		5d. PROJECT NUMBER	
		5e. TASK NUMBER	
		5f. WORK UNIT NUMBER	
7. PERFORMING ORGANIZATION NAME(S) AND ADDRESS(ES) <b>Air Force Weapons Laboratory</b>		8. PERFORMING ORGANIZATION REPORT NUMBER	
9. SPONSORING/MONITORING AGENCY NAME(S) AND ADDRESS(ES)		10. SPONSOR/MONITOR'S ACRONYM(S)	
		11. SPONSOR/MONITOR'S REPORT NUMBER(S)	
12. DISTRIBUTION/AVAILABILITY STATEMENT <b>Approved for public release, distribution unlimited</b>			
13. SUPPLEMENTARY NOTES <b>See also ADM002371. 2013 IEEE Pulsed Power Conference, Digest of Technical Papers 1976-2013, and Abstracts of the 2013 IEEE International Conference on Plasma Science. Held in San Francisco, CA on 16-21 June 2013. U.S. Government or Federal Purpose Rights License</b>			
14. ABSTRACT <b>The characteristics of electrically exploded foil fuses operated with no parallel load under varying temperature and heat transfer conditions are investigated. A 60 KJ 60 KV capacitive energy storage system operated at 39 KJ is used to vaporize aluminum and copper fuses which are surrounded by small room temperature glass beads, glass beads cooled to approximately 80K, room temperature deionized water and liquid nitrogen. Different granular quenches with substantially differing coefficients of heat transfer are also tested with aluminum fuses. Initial fuse temperature is seen to have a significant effect on fuse performance as predicted in computational simulations with aluminum being more affected than copper.</b>			
15. SUBJECT TERMS			
16. SECURITY CLASSIFICATION OF:			17. LIMITATION OF ABSTRACT
a. REPORT <b>unclassified</b>	b. ABSTRACT <b>unclassified</b>	c. THIS PAGE <b>unclassified</b>	<b>SAR</b>
			18. NUMBER OF PAGES <b>4</b>
			19a. NAME OF RESPONSIBLE PERSON

corrections for the voltage and current traces. Figure 4 shows a comparison of experimental and circuit model voltages obtained from this process where the inductive component of the fuse voltage has been removed.

The experiments were divided into three related areas. The first area was the testing of aluminum and copper fuses in four different quench environments. The cross-section of the copper fuse was 69 percent of the aluminum fuse to maintain approximately the same room temperature current interruption time. The length was chosen such that both fuses were driven well into vaporization. Fuse geometry was constant for copper fuses but aluminum fuses were 10 percent longer for room temperature shots than for cooled shots. The second area of experimentation consisted of varying the cross-section of cooled sand quench and room temperature sand quench aluminum fuses to maintain a constant fuse mass with the object of obtaining the same firing time for both fuses. The final area involved aluminum fuses of constant geometry in quenches of varying heat transfer and heat capacity properties in both room temperature and cold environments.

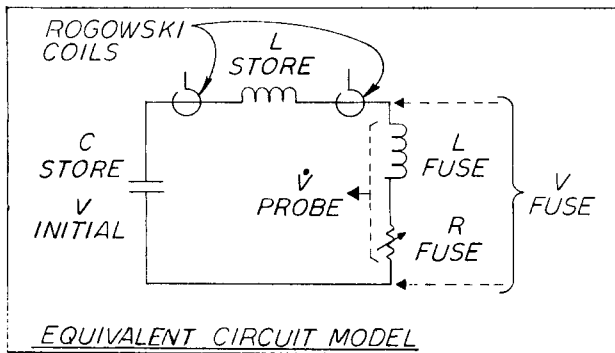

FIGURE 1

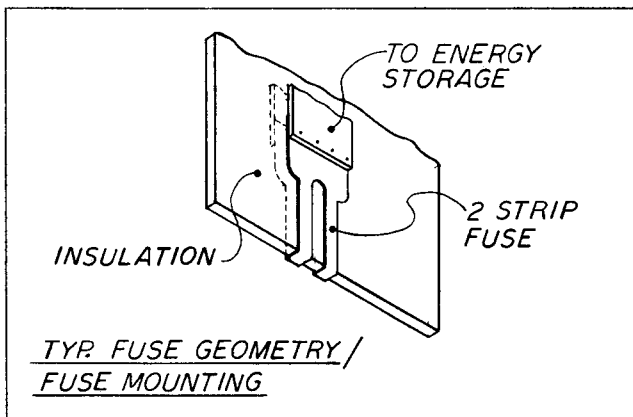

FIGURE 2

The first set of experiments used copper and aluminum fuses in four different environments. The quench media of #12 Blast-o-Lite soda-lime glass beads (which is the quench commonly used in operational fuses at the AFWL) was used at both room temperature and near liquid nitrogen temperature. The cooling was accomplished using a liquid nitrogen filled tank surrounding the fuse package but separated from the quench by a plastic envelope. Cooling times of over two hours were used to ensure the glass beads were near 77K. The other two environments were liquid nitrogen and deionized water used directly as quenches to study the effects of room temperature and cryogenic semi-incompressible media as compared to granular quenches. Figure 5 shows the fuse voltage traces corrected for the fuse inductive drop

voltage traces corrected for the fuse inductive drop for the four environments using aluminum fuses. Note that the horizontal axis is in units of quarter period rather than time. The period referred to here is the period found by taking the LC response using the system capacitance and the system inductance plus the fuse inductance. This was done because of unavoidable differences in fuse inductances and the dependence of fuse behavior on initial from shot to shot and the dependence on fuse behavior due to preopening circuit parameters. As a qualitative means of comparison, the slope of the rising voltage is a function of  $dR/dt$  of the fuse while the peak value of the voltage and time constant of the droop are indicative of the peak resistance of the fuse. Therefore, fast voltage rises, high peak voltages, and slower decay are indicators of improved performance. It can be seen that the fuse in LN2 opens later than the fuse in water and the fuse in cold sand opens later than in room temperature sand. So the colder environment results in later opening of the same fuse.

Figure 6 shows the current and resistivity of the aluminum fuses. The current traces are of interest in that they show a significant increase in the energy stored in the inductor for the same size fuse. The liquid quenches show a 70 percent increase in the energy stored in the inductor from the room temperature to the cold quench while the sand quenches show a more modest 13 percent increase in the stored energy. The current in the liquid nitrogen bath also approaches near maximum short circuit current. From the resistivity curves it can be seen that the early time behavior of the fuses has changed (is of a longer duration) while the late time behavior (after beginning a significant change in resistivity) is similar for each type of quench. One area of special interest in the resistivity figure is where the resistivity begins its steep rise. The sand quenches have much more pronounced transitions which result in higher  $dR/dt$  than do the liquid quenches. This may be attributed to the incompressibility of the liquids which exert a very high pressure on the fuse which causes the fuse phase change from solid to liquid not to be abrupt. The high

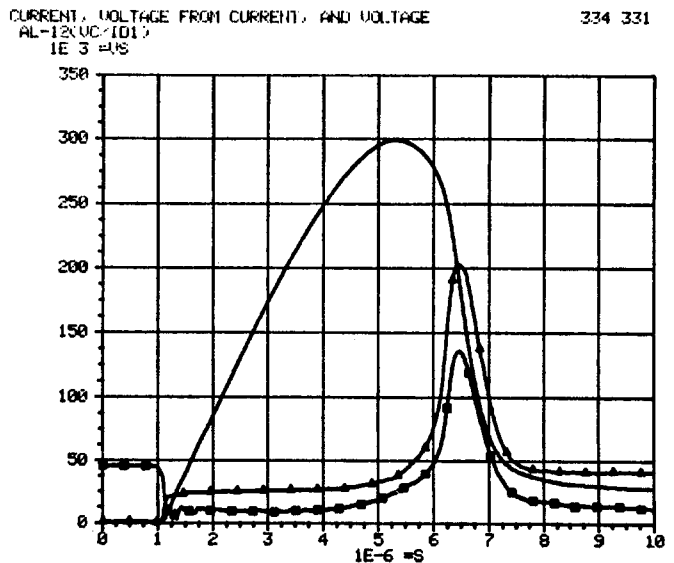

Figure 3. Typical Prefinal Calibration Voltage and Current

The two voltages shown are the experimental voltage marked with the triangular symbol and the voltage generated by the current applied to the circuit model which is marked with the square symbol. The current is unmarked.

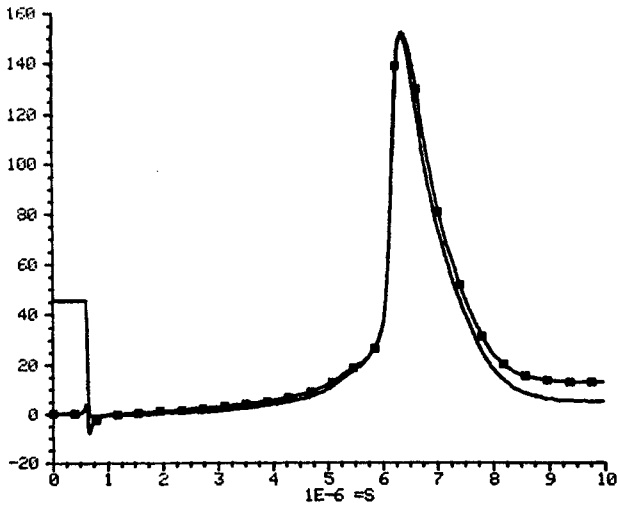

Figure 4. Typical Voltage Match After Final Calibration

The fuse inductance voltage drop has been removed. The curve with the symbols superimposed is the experimental value. The voltages typically vary the most in the tails.

pressure may be attributed to the superheating of the liquid adjacent to the fuse or to the expansion of the fuse upon heating or a combination of the two events. The fuse liquifies in stages leading to less abrupt changes in resistivity. In the sand quench the pressure is very low and the change of state may take place rapidly hence the more pronounced change in resistivity. Another area of interest on the resistivity curve is the large drop in resistivity after the initial rise for the liquid quenched fuses. This may be attributed to the quench media in that the vaporized fuse does not mix with its environment but maintains a channel that is ionized whereas the granular quench physically interrupts the ionization process as the metal vapor plates around the individual beads of the quench. This process is seen in both aluminum and copper fuses so one must conclude that these resistivity features are functions of the quench rather than the fuse material. Figure 7 shows the behavior of aluminum fuses with respect to specific energy. The interesting features here are the decrease in resistivity after the initial maximum and the lower resistivity between boiling and vaporization in the liquid quench. The decrease takes place at the same energy in the liquid medium indicating that is a characteristic of the quench medium.

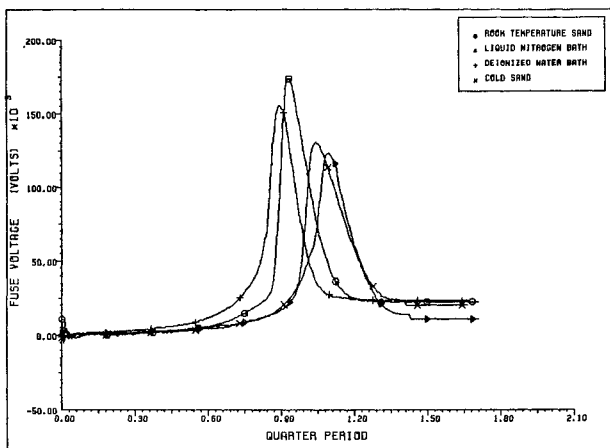
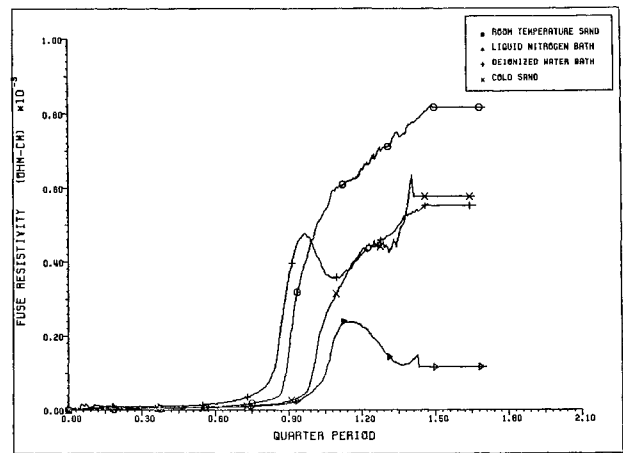
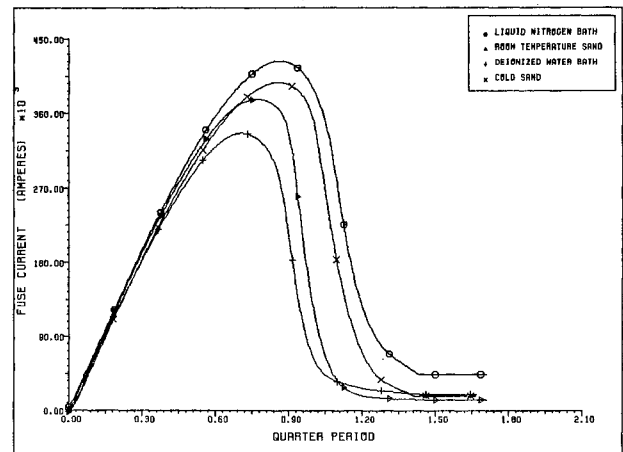

Figure 5. Aluminum Fuse Voltages (Fuse inductive drop removed)

Note: Horizontal tails are artificial



b.



a.

Figure 6. Aluminum Fuse a) Current b) Resistivity

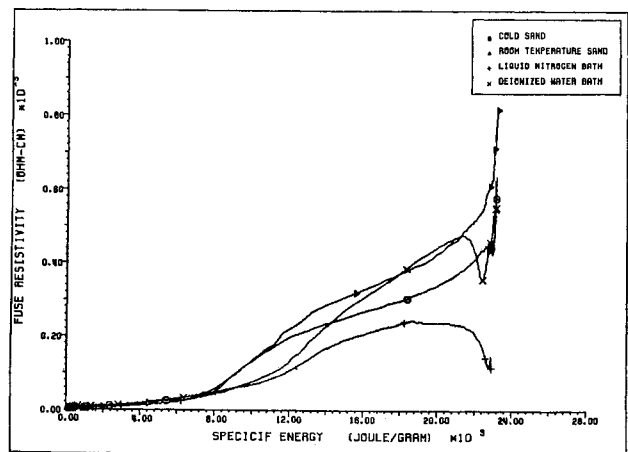

Figure 7. Resistivity Vs Specific Energy

Copper fuses were tested under the same conditions as the aluminum fuses. The copper fuses did not exhibit the same delay from room temperature to cold sand as did the aluminum fuses. A delay was seen when the copper fuse was exploded in the liquid nitrogen bath, however. The copper fuses behaved similarly to the aluminum fuses with the affect of the cold environment being less significant.

The second set of experiments was designed to measure directly the improvement of fuse resistance between a cooled aluminum fuse and a room temperature aluminum fuse in a sand quench. The mass of the fuse was held constant. Figure 8 compares the change in resistance between the two fuses. As can be seen, the room

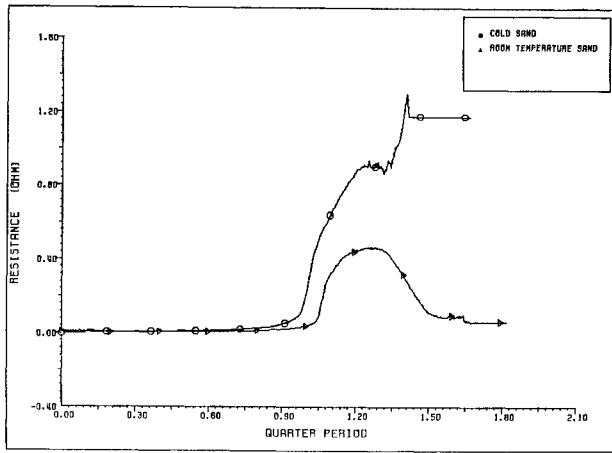

Figure 8. Resistance Change Between a Cold Fuse and a Room Temperature Fuse in Sand Quench With Similar Opening Times.

Cold Fuse Measures 8x40 cm and Room Temperature Fuse Measures 11.5x33.5 cm, Both Fuses one mil thick.  
Note: Horizontal tails are artificial

temperature fuse opened later than the cold fuse in terms of the period. This difference in time indicates that the room temperature fuse is wider and shorter than necessary to give the same opening time of the cold fuse and therefore, the resistance of the room temperature fuse is a little lower than one would find with the same opening time. Fuses with shorter opening times than the cold fuse exhibited lower resistance than the cold fuse which indicates that this comparison is not unreasonable. The improvements that could result from using a cold fuse instead of a room temperature fuse would be those of 1) increased-current if the fuse geometry was held constant resulting in increased energy in the inductive store and 2) increased resistance if the opening time of the fuse were held constant by reducing the cross-section of the fuse and increasing its length which would improve energy transfer to a resistive load.

The third set of experiments was designed to investigate the effect of heat transfer on fuse performance. Aluminum fuses of a constant geometry were tested in room temperature and cold environments using quenches of different heat capacities and thermal conductions. Figure 9 shows the results of these experiments. Table 1 compares the thermal properties of the quenches. Note that most values in Table 1 are for solid material and the quenches they correspond to are granular. The density of the quench is lower and consequently the  $k\rho c$  is lower so the thermal transfer effect should be much less apparent.

TABLE 1

MATERIAL	DENSITY $\rho$ (KG/M3)	SPECIFIC HEAT $c$ (J/KG.K)	THERMAL CONDUCTIVITY $k$ (J/M.K.S)	THERMAL DIFFUSIVITY $k/c\rho$ (M2/S)	$k\rho c$
silicon dioxide	2.2E3	7.5E2	5.9	3.58E-6	3.13E3
sand (granular)	1.5E3	8.E2	2.7E-2	2.23E-8	1.81E2
alumina	3.97E3	7.3E2	35.0	1.2E-5	1.0E4
silicon carbide	3.16E3	6.75E2	4.9E2	2.3E-4	3.23E4
water (liquid)	1.0E3	4.2E3	1.7	4.05E-7	2.67E3
nitrogen (liquid)	8.1E2	2.04E3	0.46	2.7E-8	8.68E2

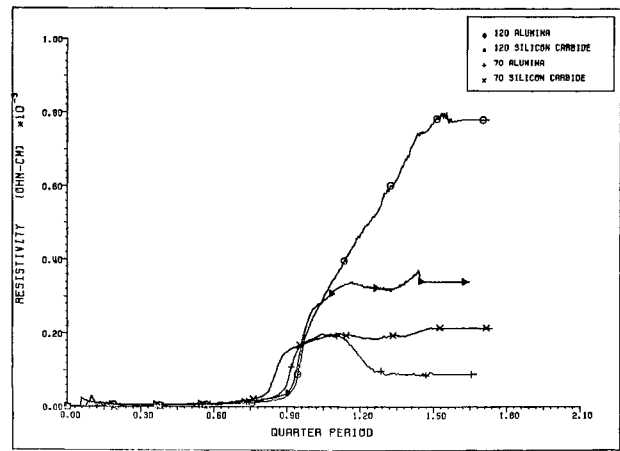

Figure 9. Resistivity of Aluminum Fuses

Different quench materials and grit sizes.  
Note: Horizontal tails are artificial

### CONCLUSIONS

The effect of initial temperature on fuse performance is seen to occur in the early time resistivity of the fuse. Colder aluminum fuses open later than similar room temperature fuses. This allows the designer to use a narrower and presumably a longer fuse in a cold environment and therefore achieve higher resistances as seen by the load. Heat transfer to the medium does not seem to have an effect of early time fuse performance. The varying quenches investigated showed different late time effects but this is a well known condition and is not unexpected.<sup>2</sup>

### REFERENCES

1. Stuerke, C. et al. "Multi-Megamp, Multi-Terawatt Inductive Pulse Compression System Operation", Digest of Technical Papers, 3rd International Pulsed Power Conference, Albuquerque, NM, (June 1981).
2. Henderson, R. P. et al. "Preliminary Inductive Energy Transfer Experiments", Digest of Technical Papers, 2nd IEEE International Pulsed Power Conference, 347-350, Lubbock, Texas (1979).
3. Reinovsky, R. E. et al. "Inductive Store Pulse Compression System for Driving High Speed Plasma Implosions", IEEE Transactions on Plasma Science, PS-10 (2), June 1982.
4. Reinovsky, R. E. and Smith D. L. "Fuse Switches for High Current Inductive Pulse Compression Systems", Final Report on Proceedings, ARO Proceedings Workshop on Repetitive Opening Switches, Durango CO (January 1981)
5. McCullogh, W. Private Communication, Kirtland AFB, N.M. (1983).
6. Bueck, J. C. "Comparison of Aluminum and Copper Fuse Opening Switches Under Room and Cryogenic Temperature Conditions", Thesis, Air Force Institute of Technology (December 1982), (AFIT/GE/EE/82D-22).
7. Maisonnier, C. et al. "Rapid Transfer of Magnetic Energy by Means of Exploding Foil", Review of Scientific Instruments, 30(11):p1032-1037 (October 1966)