

AN INEXPENSIVE SOLID STATE TRIGGER UNIT FOR THYRATRONS*

E. Steve Fulkerson
Lawrence Livermore National Laboratory
P.O. Box 5508, L-484
Livermore, CA 94550

Summary

An SCR based unit suitable for triggering thyratrons has been developed. It is capable of developing over a kilovolt peak into a 50 ohm load with a risetime of under ten nanoseconds. Both grounded grid and common cathode styles of thyratrons may be driven with minor circuit changes. Jitter characteristics show less than half a nanosecond peak to peak, and a standard deviation less than 100 picoseconds has been obtained.

Introduction

This unit was originally developed for the Nova laser plasma shutter. The plasma shutter explodes a fine aluminum foil into the laser beam path to block reflected light from the target. This retro-pulse could cause severe damage to the optics if allowed to re-enter the laser chain. The plasma shutter uses four rail type spark gaps to switch out over 500 kiloamperes to explode the foil. These rail gaps are triggered by two redundant grounded grid thyatron based units. This paper will discuss the development and performance of the solid state drivers for these thyratrons.¹

In earlier thyatron triggers a solid state driver using fast SCR's (Unitrode GA-201) in an avalanche mode was used.² This circuit worked well but had several shortcomings. First a 1,000 volt power supply was required to produce a 600 volt peak output. The fast SCR's are costly and require a selection process. A final negative consideration was the susceptibility of the avalanche type unit to trigger on external noise (a special problem in the plasma shutter application).

The disadvantage of having to use a separate 1,000 volt power supply led to the development of this new circuit. An SCR switched Marx generator was selected. A Marx generator charges capacitors in parallel over a long time period, then discharges them in series to produce a fast risetime pulse with a voltage multiplication effect. SCR's were again chosen as the switching elements because they had demonstrated their ability to survive the severe transients associated with driving grounded grid thyratrons.

Schematic Diagram

An abbreviated schematic diagram is shown in Figure 1. The unit basically consists of six identical Marx type stages with an optical trigger receiver. Only three of these stages have been shown for simplicity. The six capacitor banks are charged through the 47K resistors to the supply voltage. Three capacitors are used in each stage to minimize the series impedance of the Marx which strongly affects the load driving ability of the device.

The first SCR (Q1) is triggered by a fiber optic signal received by one of the photodiodes. Two diodes are provided as both system and local test triggers are required for the plasma shutter thyatron trigger units. The parallel resistors R5-R9 provide an acknowledge signal back to the plasma shutter timing system indicating the Marx stack has fired.

When Q1 fires it takes the positive side of the C2-C4 capacitor bank to near ground potential. The capacitors attempt to discharge through R10 but are prevented from doing so by the long time constant involved. SCR Q2 now sees not only the positive voltage on its own anode but also the negative side of the first capacitor bank. Thus the voltage applied to the second SCR is effectively twice the supply. This combined voltage exceeds the forward breakdown ratings of Q2 and the SCR fires. It should be noted that the voltage from the first capacitor bank is applied quite rapidly, much faster in fact than the rated Forward Voltage Application Rate (dv/dt) of the device. This contributes to the triggering of the SCR. Finally, capacitor C23 provides a path for some of the first capacitor bank's energy to discharge through the gate of Q2 to ground, again aiding in the rapid triggering of the second SCR.

It can be seen that the rest of the stack erects in a similar manner. At this point all the capacitor banks are effectively in series and can provide power to the load. The output waveform (an RC tail) can be seen in Figure 2. CR3-CR4 provide transient isolation preventing prefires of the Marx generator caused by noise spikes from the load.

SCR Selection

The original version of this device was constructed with Unitrode GA-201 SCR's. These are very fast devices with a rated turn on time under twenty nanoseconds. They produce very good results with a risetime in the Marx of five to six nanoseconds with very little forward drop resulting a large output voltage for the supply used. As noted before these devices are costly and are only rated for 100 volts, limiting the output voltage of the Marx. These limitations led to further experiments to find a substitute type. Surprisingly, almost all types of small SCR's tried worked well. The most interesting factor was their exhibited risetime in the Marx generator. All the devices tested showed a risetime in the ten to 20 nanosecond range. This is interesting in light of the fact that all of these devices are rated for turn-on times of one to two microseconds. It would appear that the triple combination of being overvoltaged, applying a forward voltage faster than their rated dv/dt, and the diversion of some current from the preceding stage to the gate result in a very fast turn-on time. A four-to-one speed up was noted for the fast device, but a hundredfold improvement was obtained in the slower rated SCR's.

*This work was performed under the auspices of the U.S. Department of Energy by the Lawrence Livermore National Laboratory under Contract No. W-7405-ENG-48.

Report Documentation Page

Form Approved
OMB No. 0704-0188

Public reporting burden for the collection of information is estimated to average 1 hour per response, including the time for reviewing instructions, searching existing data sources, gathering and maintaining the data needed, and completing and reviewing the collection of information. Send comments regarding this burden estimate or any other aspect of this collection of information, including suggestions for reducing this burden, to Washington Headquarters Services, Directorate for Information Operations and Reports, 1215 Jefferson Davis Highway, Suite 1204, Arlington VA 22202-4302. Respondents should be aware that notwithstanding any other provision of law, no person shall be subject to a penalty for failing to comply with a collection of information if it does not display a currently valid OMB control number.

1. REPORT DATE JUN 1983		2. REPORT TYPE N/A		3. DATES COVERED -	
4. TITLE AND SUBTITLE An Inexpensive Solid State Trigger Unit For Thyratrons				5a. CONTRACT NUMBER	
				5b. GRANT NUMBER	
				5c. PROGRAM ELEMENT NUMBER	
6. AUTHOR(S)				5d. PROJECT NUMBER	
				5e. TASK NUMBER	
				5f. WORK UNIT NUMBER	
7. PERFORMING ORGANIZATION NAME(S) AND ADDRESS(ES) Lawrence Livermore National Laboratory P.O. Box 5508, L-484 Livermore, CA 94550				8. PERFORMING ORGANIZATION REPORT NUMBER	
9. SPONSORING/MONITORING AGENCY NAME(S) AND ADDRESS(ES)				10. SPONSOR/MONITOR'S ACRONYM(S)	
				11. SPONSOR/MONITOR'S REPORT NUMBER(S)	
12. DISTRIBUTION/AVAILABILITY STATEMENT Approved for public release, distribution unlimited					
13. SUPPLEMENTARY NOTES See also ADM002371. 2013 IEEE Pulsed Power Conference, Digest of Technical Papers 1976-2013, and Abstracts of the 2013 IEEE International Conference on Plasma Science. Held in San Francisco, CA on 16-21 June 2013. U.S. Government or Federal Purpose Rights License.					
14. ABSTRACT					
15. SUBJECT TERMS					
16. SECURITY CLASSIFICATION OF:			17. LIMITATION OF ABSTRACT	18. NUMBER OF PAGES	19a. NAME OF RESPONSIBLE PERSON
a. REPORT unclassified	b. ABSTRACT unclassified	c. THIS PAGE unclassified			

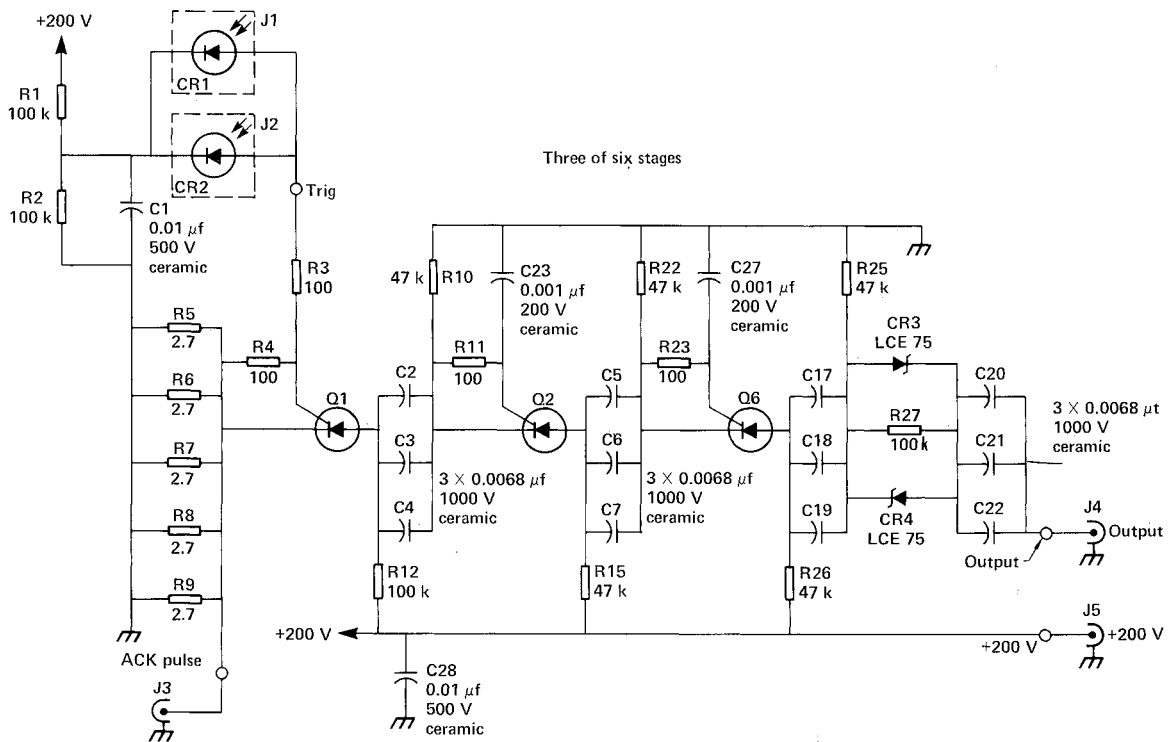

FIGURE 1

ABBREVIATED SCHEMATIC DIAGRAM

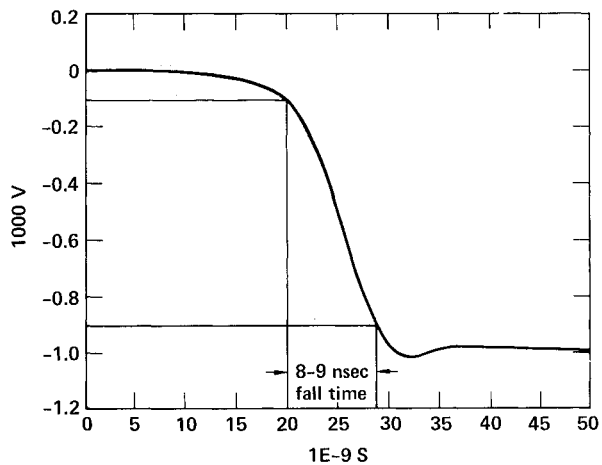

FIGURE 2A
OUTPUT WAVEFORM

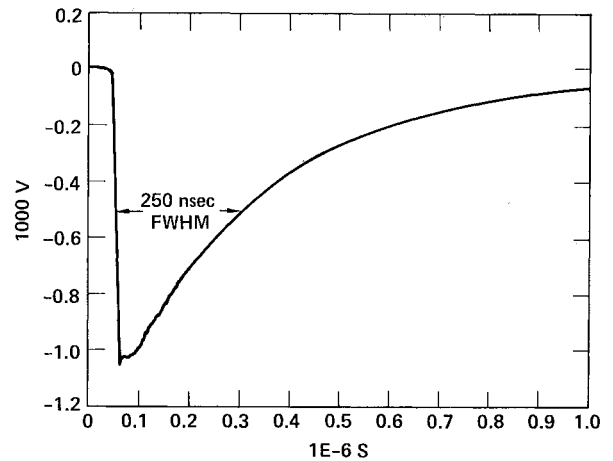

FIGURE 2B
OUTPUT WAVEFORM

After some experimenting, the Motorola MCR22 typed was decided on. This device is intended for automotive ignition service and is rated for 150 amps peak in short (microsecond) pulses. They are small (TO-92) plastic packages, and priced less than a dollar each in quantity. These SCR's exhibited a lower forward voltage drop than other inexpensive types tested, resulting in somewhat higher output voltages. The devices come in voltage ratings up to six hundred volts. The MCR22 is rated for a turn on time of 1.2 microseconds, and exhibits a risetime of eight to nine nanoseconds in the Marx generator.

Performance

The output waveform, as measured into a fifty ohm load, is shown in Figure 2. Risetime is in the eight to nine nanosecond range, 10 to 90 percent. Peak output voltage is over one kilovolt with a pulse width at half maximum of 250 nanoseconds. The supply voltage is 400 volts.

A plot of output voltage versus supply voltage is shown in Figure 3. As can be seen the relationship between the supply and output is quite linear. The ratio of supply to voltage out is 1:2.5. With perfect switches and capacitors the output would be the supply voltage multiplied by the number of stages. However, non-ideal components yield about 12 ohms of series impedance for each stage, or about 72 ohms for this circuit. This series impedance reduces the multiplication effect of the Marx generator.

Delay through the device varies considerably with the supply. As the supply voltage is increased the delay decreases, delay may be minimized by choosing SCR's with a forward voltage rating close to the operating supply voltage. A plot of transport delay versus supply voltage is also shown in Figure 3. The graph shown is for the Motorola MCR22-8, a 600 volt device, and will vary with the rating of the SCR used. As can be seen from the plot, delay falls off rapidly at first as supply is increased, then stabilizes as the supply nears the rating of the device. The Marx generator shown has a delay of 180 nanoseconds at its 200 volt operating point in the plasma shutter application.

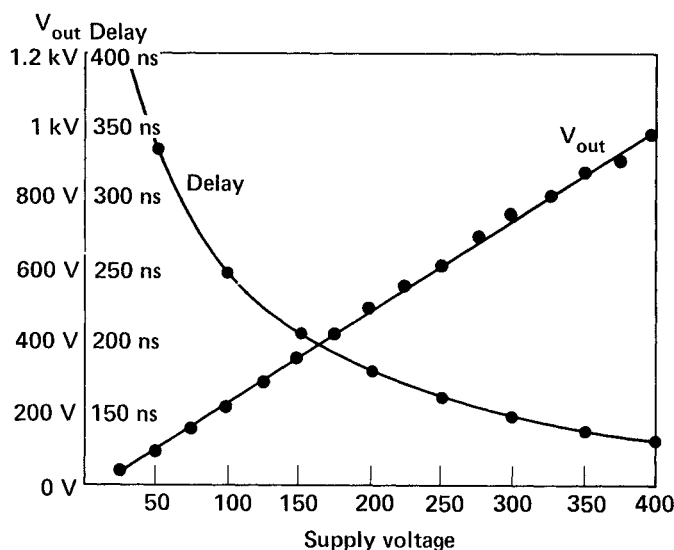

FIGURE 3

V_{OUT} AND DELAY VERSUS SUPPLY VOLTAGE

Jitter and drift characteristics have proven to be excellent. As can be inferred from the discussion above both jitter and long term drift are closely tied to the stability of the supply. Jitter studies conducted with an HP5370A time interval counter show a peak-to-peak jitter, for ten thousand shots, of less than 400 picoseconds, with a standard deviation less than 65 picoseconds. These tests were conducted with a +200 volt supply at a 100 HZ repetition rate.

The limiting factor in repetition rate is the value of the resistors used to charge the capacitor banks. As can be seen in the schematic diagram of Figure 1, the charging resistors determine the holding current of the SCR's. If the value of these resistors is too low the current will never drop below the holding current of the device, and the SCR will not recover. The typical holding current for the MCR-22 series is two milliamperes. Thus the value of the charging resistors must be kept relatively high resulting in a long RC time constant limiting the repetition rate to near 100 HZ. Decreasing the value of the capacitor banks will allow operation to higher rates, but at the sacrifice of output pulse width. One possible solution being investigated is to actively interrupt the supply after each shot to allow the SCR's to recover even with small values of charge resistors.

Applications

The circuit as discussed to this point produces a negative output pulse suitable for triggering grounded grid type thyratrons (such as EG&G's HY-1102), as it is utilized in the plasma shutter. However, common cathode thyratrons require a positive voltage trigger. A small coaxial transfer is used to provide the necessary inversion without compromising the output risetime. The transformer consists of sixteen turns of RG-174 coaxial cable on a ferrite core, (Indiana General P/N F626-12-05). The input is applied to the shield of the coax with the center conductor grounded. The output is taken from the opposite end of the cable in the conventional manner, with the shield at ground and the inverting output taken from the center conductor (see Figure 4).

When driving tetrode thyratrons, (EEV CX-1157, EG&G HY-8), the signal applied to the second grid must be delayed in time from the auxiliary grid drive unless a DC priming current is used on the auxiliary grid. The circuit shown in Figure 4 has proven quite successful with an overall peak-to-peak system jitter less than half a nanosecond being demonstrated. The 100 nanosecond delay shown has proven adequate in this application to produce minimum jitter.

Conclusions

Driving thyratrons is a difficult application for solid state devices. Switching transients returning from thyatron grids, (or cathodes), can be many kilovolts and contain substantial energy. This development program has produced a small, inexpensive, and survivable trigger of high performance suitable for driving a wide range of thyatron with excellent reliability and very low jitter.

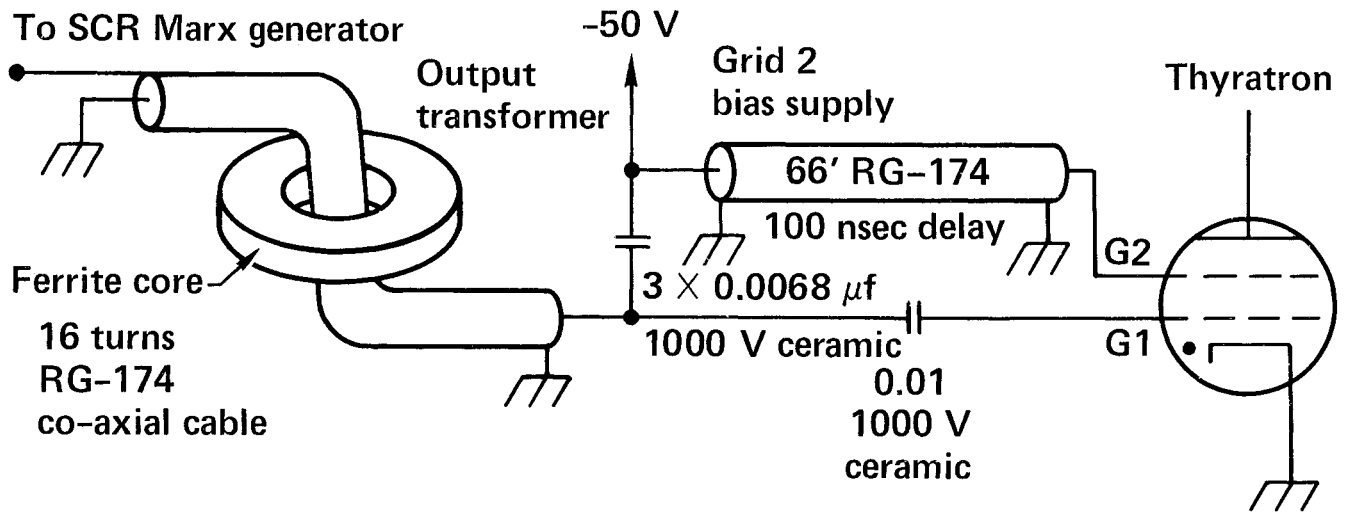

FIGURE 4
DRIVING TETRODE THYRATRONS

References

1. J. A. Oicles, E. S. Fulkerson, "An Improved 50 KV Pulser Design" 15th Power Modulator Symposium, Baltimore, Maryland, 1982.
2. J. A. Oicles, E. S. Fulkerson, "A Reliable Trigger Unit for Rail Gap Switches" 9th Symposium on Engineering Problems of Fusion Research, Chicago, Illinois, 1981.

DISCLAIMER

This document was prepared as an account of work sponsored by an agency of the United States Government. Neither the United States Government nor the University of California nor any of their employees, makes any warranty, express or implied, or assumes any legal liability or responsibility for the accuracy, completeness, or usefulness of any information, apparatus, product, or process disclosed, or represents that its use would not infringe privately owned rights. Reference herein to any specific commercial products, process, or service by trade name, trademark, manufacturer, or otherwise, does not necessarily constitute or imply its endorsement, recommendation, or favoring by the United States Government or the University of California. The views and opinions of authors expressed herein do not necessarily state or reflect those of the United States Government thereof, and shall not be used for advertising or product endorsement purposes.