

UNCLASSIFIED

SECURITY CLASSIFICATION OF THIS PAGE

REPORT DOCUMENTATION PAGE

1a. REPORT SECURITY CLASSIFICATION Unclassified			1b. RESTRICTIVE MARKINGS		
2a. SECURITY CLASSIFICATION AUTHORITY			3. DISTRIBUTION/AVAILABILITY OF REPORT Approved for public release; Distribution unlimited.		
2b. DECLASSIFICATION/DOWNGRADING SCHEDULE			4. PERFORMING ORGANIZATION REPORT NUMBER(S) NMERI WA3-10		
4. PERFORMING ORGANIZATION REPORT NUMBER(S) NMERI WA3-10			5. MONITORING ORGANIZATION REPORT NUMBER(S) ESL TR-85-62		
6a. NAME OF PERFORMING ORGANIZATION New Mexico Engineering Research Institute		6b. OFFICE SYMBOL (If applicable) NMERI	7a. NAME OF MONITORING ORGANIZATION Engineering and Services Laboratory		
6c. ADDRESS (City, State and ZIP Code) Box 25, University of New Mexico Albuquerque, New Mexico 87131			7b. ADDRESS (City, State and ZIP Code) Air Force Engineering and Services Center Tyndall Air Force Base, Florida 32403		
8a. NAME OF FUNDING/SPONSORING ORGANIZATION AFESC/RD and NAVAIR		8b. OFFICE SYMBOL (If applicable)	9. PROCUREMENT INSTRUMENT IDENTIFICATION NUMBER Contract No. F29601-84-C-0080		
8c. ADDRESS (City, State and ZIP Code) (Air Force) - Tyndall AFB FL 32403-6001 (NAVAIR) - Washington DC 20361			10. SOURCE OF FUNDING NOS.		
11. TITLE (Include Security Classification) Three Dimensional Fire Extinguishant			PROGRAM ELEMENT NO.	PROJECT NO.	TASK NO.
12. PERSONAL AUTHOR(S) Harold D. Beeson, Dennis M. Zallen, Phyllis Campbell, and Joseph L. Walker			WORK UNIT NO.		
13a. TYPE OF REPORT Task/Milestone Report		13b. TIME COVERED FROM 1-85 TO 9-85	14. DATE OF REPORT (Yr., Mo., Day) 1985 September		15. PAGE COUNT 84
16. SUPPLEMENTARY NOTATION					
17. COSATI CODES			18. SUBJECT TERMS (Continue on reverse if necessary and identify by block number)		
FIELD	GROUP	SUB. GR.			
19. ABSTRACT (Continue on reverse if necessary and identify by block number)					
This report covers the development of a three-dimensional (3-D) small-scale agent-scoping apparatus, the scoping of several baseline agents, and the characterization of a 3-D fire. The scenario used was to simulate a postcrash situation where fuel is cascading onto a sloping surface and collecting in a pool. To fully characterize this situation, a running-fuel fire, where fuel is running down an incline and collecting in a pool, was first characterized and agent effectiveness on a running-fuel fire was evaluated. An agent scoping/fire characterization apparatus was then developed and used to develop concepts relating to 3-D fires. Based on this study it was recommended that a search be conducted for a three-dimensional agent with superior fuel inertion capabilities which would not suffer from the application, environmental, cleanliness, and toxicity problems of existing agents. The goal of such a study would be the development of a new first-line fire-fighting agent.					
20. DISTRIBUTION/AVAILABILITY OF ABSTRACT UNCLASSIFIED/UNLIMITED <input checked="" type="checkbox"/> SAME AS RPT. <input type="checkbox"/> DTIC USERS <input type="checkbox"/>			21. ABSTRACT SECURITY CLASSIFICATION UNCLASSIFIED		
22a. NAME OF RESPONSIBLE INDIVIDUAL JOSEPH L. WALKER			22b. TELEPHONE NUMBER (Include Area Code) (904) 283-6194	22c. OFFICE SYMBOL HQ AFESC/RDCF	

DISCLAIMER

This document is submitted as an historical record of work performed. Limitations of the available media rendered editing impractical; therefore it is retained "as is."

FEDERAL LABORATORY TECHNOLOGY APPLICATION ASSESSMENT



DEPARTMENT OF THE AIR FORCE
HEADQUARTERS AIR FORCE ENGINEERING AND SERVICES CENTER
TYNDALL AIR FORCE BASE, FLORIDA 32403



THREE-DIMENSIONAL FIRE EXTINGUISHANT

A. OBJECTIVE

The objective of this effort was to develop and test concepts for a suppression agent to combat three-dimensional fires.

B. SUMMARY

This effort involved the development of a three-dimensional (3-D) small-scale agent-scoping apparatus, the scoping of several baseline agents, and the characterization of a 3-D fire. The scenario used was to simulate a postcrash situation where fuel is cascading onto a sloping surface and collecting in a pool. To fully characterize this situation, a running-fuel fire, where fuel is running down an incline and collecting in a pool, was first characterized and agent effectiveness on a running-fuel fire was evaluated. An agent scoping/fire characterization apparatus was then developed and used to develop concepts relating to 3-D fires. Based on this study it was recommended that a search be conducted for a three-dimensional agent with superior fuel inertion capabilities which would not suffer from the application, environmental, cleanliness, and toxicity problems of existing agents. The goal of such a study would be the development of a new first-line firefighting agent.

C. STAGE OF DEVELOPMENT

The present study is complete.

D. USER/PLANNED ACTION

HQ AFESC/RDCF and the Major Air Commands will use the information obtained in this study to aid in the development of advanced fire extinguishing agents which are effective against a 3-D fire.

E. PATENT OR PROPRIETARY STATUS

No patent action will be taken.

F. PUBLICATIONS

H. D. Beeson and D. M. Zallen, Three-Dimensional Fire Extinguishant, ESL-TR-85-62, September 1985.

G. ADDITIONAL INFORMATION

J. Walker, Chief, Fire Technology Branch, HQ AFESC/RDCF Tyndall AFB FL 32043, Telephone: 904/283-6283, AUTOVON 970-6283. Request copies of publication from NTIS.

JOSEPH L. WALKER
Chief, Fire Technology Branch

LAWRENCE D. HOKANSON, Lt Col, USAF
Director of Engineering & Services
Laboratory

RD 16

Col H signature block needed
below Walker

PREFACE

This report was prepared by the New Mexico Engineering Research Institute (NMERI), University of New Mexico, Albuquerque, New Mexico, under contract F29601-84-C-0080 (Subtask 3.08). This work was sponsored by the Engineering and Services Laboratory, Air Force Engineering and Services Center, Tyndall Air Force Base Florida 32493, and the Naval Air Systems Command, HQ NAVAIR, Washington, DC 20361. The AFESC/RDCF project officer was Mr. Joseph L. Walker and the NAVAIR project officer was Ms. Phyllis Campbell. This report summarizes work done between 7 January 1985 and 30 September 1985.

The assistance of Dr. Robert Tapscott and Mr. Martin Plugge is appreciated. Special acknowledgment is due the project technicians, James D. Watson, Tracy A. Goss, Thomas M. Trujillo, and Jesse M. Parra.

This report has been reviewed by the Public Affairs Office (PA) and is releasable to the National Technical Information Service (NTIS). At NTIS, it will be available to the general public.

This technical report has been reviewed and is approved for publication.

JOSEPH L. WALKER
Chief, Fire Technology Branch

LAWRENCE D. HOKANSON, Lt Col, USAF
Director of Engineering & Services
Laboratory

TABLE OF CONTENTS

Section	Title	Page
I.	INTRODUCTION	1
	A. OBJECTIVE	1
	B. BACKGROUND	1
	C. SCOPE	2
II.	AGENT SURVEY	3
	A. SINGLE COMPONENT AGENTS.....	3
	B. MULTICOMPONENT AGENTS	6
III.	APPARATUS DEVELOPMENT	9
IV.	AGENT-SCOPING STUDIES	14
	A. 2-D RUNNING-FUEL FIRE.....	14
	B. 2-D AGENT SCOPING SUMMARY.....	20
	C. 3-D FUEL FIRE WITH CASCADE.....	22
V.	3-D FIRE CHARACTERIZATION	30
	A. EXPERIMENTAL	30
	B. RESULTS AND DISCUSSION.....	32
VI.	CONCLUSIONS AND RECOMMENDATIONS	43
	REFERENCES	48
	APPENDIX A	51

LIST OF TABLES

Table	Title	Page
1	1211 Effectiveness on 2-D Running-Fuel Fire	15
2	2402 Effectiveness on 2-D Running-Fuel Fire	16
3	6-Percent AFFF Effectiveness on 2-D Running-Fuel Fire	18
4	Effectiveness of 3-Percent AFFF on 2-D Running-Fuel Fire	18
5	Dual-Agent Application Effectiveness of 6-Percent AFFF/PKP on 2-D Running-Fuel Fire	19
6	Effectiveness of Dual-Agent Application of 1211 and 3-Percent AFFF on 2-D Running Fuel Fire	19
7	Combination Agent 1211/2402 Effectiveness on 2-D Running-Fuel Fire	21
8	Effectiveness of 2402 on 3-D Cascading-Fuel Fire	24
9	Effectiveness of PKP on 3-D Cascading-Fuel Fire	24
10	Effectiveness of 1211/AFFF on 3-D Cascading-Fuel Fire	25
11	Effectiveness of 2402/AFFF on 3-D Cascading-Fuel Fire	25
12	Effectiveness of 2402/1211 Combination Agent on 3-D Cascading-Fuel Fire	26
13	Extinguishment of 2-Foot X 4-Foot Pan Fire by 2402	28
14	Fire Characterization Results for 2-Foot X 4-Foot Pan Fire	34

LIST OF TABLES (CONCLUDED)

Table	Title	Page
15	Fire Characterization Results for Running-Fuel Fire	35
16	Fire Characterization of 3-D Cascading- Fuel Fire	3) 46 ✓

LIST OF FIGURES

Figure	Title	Page
1	Running-Fuel Fire Apparatus	10
2	3-D Small-Scale Agent-Scoping Apparatus	11
3	Photographs Showing Repeatability of Agent-Scoping Apparatus	13
4	Amount of Agent (2402) Necessary for Extinguishment as a Function of Dimensionality	29
5	Thermocouple Placement in 3-D Scoping Apparatus	31
6	3-D Small-Scale Agent Scoping Apparatus Showing Themocouple Placements	33
7	Effect of Dimensionality on Burn Rate	37
8	Actual Time-Temperature Results of a 3-D Test Fire	40
9	Plot of Time vs. Temperature Based on Results of Computer Model	42

SECTION I
INTRODUCTION

A. OBJECTIVE

The objective of this subtask is to develop and test concepts for a suppression agent to combat three-dimensional (3-D) fires. The specific objective of this study is to develop a small-scale agent-scoping apparatus for use in further studies.

B. BACKGROUND

The Air Force/Navy uses three primary firefighting agents for liquid-fuel fires - foam, dry chemical (PKP), and halon (1211). These agents may not be reliable in the effective extinguishment of 3-D liquid fuel fires. An example of a 3-D fire scenario is burning liquid fuel on the ground in a flowing pool, with a vertical stream of burning fuel falling toward the running pool fire. This vertical stream may take one of three forms - a fine droplet mist, a rod, or a cascade, depending upon the size and location of the fuel opening and the pressure exerted on the fuel (Reference 1). A total or partial flood (this usually involves a large amount of agent at a high cost) technique may be used to combat this type of fire in an enclosure; however, an efficient 3-D firefighting agent is needed for transportable facilities and outdoor and unprotected areas.

Previous studies have been conducted to look at 3-D fires and agent effectiveness (References 1-4); however, most of this work involved characterizations of 3-D fires and the scaling of agent delivery and application for extinguishment. George Geyer (Reference 3) in a joint Air Force/FAA study employed three different types of apparatus to study the 3-D effectiveness of dry chemical and halon agents. The tests employed in his study were an inclined plane, an engine nacelle and a landing gear assembly. The results of these tests were used to show the agent equivalency of halon and dry chemical.

Altman, et al. (Reference 4) examined the effectiveness of dry chemical extinguishing agents on engine nacelle fires. The criteria for these tests were effective extinguishments under running conditions. The dry chemical agents were evaluated as to their 3-D character and fuel-inertion capabilities under high air flows and high-temperature conditions.

In another study by Stanford Research Institute (SRI) and Naval Surface Weapons Center (NSWC) (Reference 1,2) the characteristics of rod and cascade fires were investigated. An apparatus simulating a cascade fire was developed to test agent effectiveness. The apparatus developed simulated only the cascading fire element and was developed to meet criteria of yielding a reproducible inexpensive agent evaluation and training apparatus. The parameters used to evaluate the 3-D fire included temperature, burn rate and flame structure.

This phase of the subtask involves the development of a 3-D small-scale agent-scoping apparatus, the scoping of several baseline agents, and the characterization of a 3-D fire. The scenario chosen is to simulate a postcrash situation where fuel is cascading onto a sloping surface and collecting in a pool. To fully characterize this situation, a running-fuel fire similar to that used by Geyer (Reference 3) was first characterized. This was also used for some agent-scoping to assess agent requirements upon going from a running-fuel fire to a 3-D fire. The approach taken in this phase of the subtask was to simultaneously scope existing agents (Section IV) and characterize the 3-D fire (Section V) using the selected apparatus discussed in Section III.

C. SCOPE

The scope of this work includes the following: Current agents were to be investigated as to their three-dimensionality using available literature. A small-scale agent-scoping apparatus was to be constructed and, using this apparatus, the resulting 3-D fire was to be characterized and current agents were to be evaluated for effectiveness.

SECTION II

AGENT SURVEY

As part of the initial work on this project, a series of available agents was evaluated for their 3-D characteristics. This evaluation included a series of agent-scoping tests accomplished on the developed apparatus and discussed later in this report. The agents surveyed can be combined into two general categories: (1) single-component, i.e., foams, halons, and dry chemical agents and (2) multicomponent, i.e., halon-aspirated foams, halofoams, and dual-agent applications. The evaluation of these agents was based solely on their 3-D performance for liquid fuel fires, on literature information, and on discussions with experts in the field.

A. SINGLE-COMPONENT AGENTS

1. Foams

The first recorded use of firefighting foams was in 1912 (Reference 5). The firefighting capability of foams is based on their ability to blanket the fuel surface, thereby prohibiting the reaction of the fuel with oxygen. In addition, since most firefighting foams are between 94 percent and 97 percent water, significant cooling also takes place as the agent comes in contact with the fire and the water evaporates. This flash evaporation of water will displace oxygen and is the prime mechanism whereby high-expansion foams extinguish fires in enclosed spaces (References 6 and 7).

Low-expansion foams used by the Air Force/Navy (Reference 8) have an expansion ratio of 8:1 if applied using an air-aspirating nozzle and approximately 4:1 if applied through a non-air-aspirating nozzle. Low expansion foams, in general, are not considered 3-D agents since they must blanket the fuel to suppress the fire. If the integrity of the foam blanket is disrupted, or if the fuel flows out from under the foam blanket, ignition and flashback may occur. With running or cascading-fuel fires there is no chance for a stable foam blanket to form.

High-expansion foams can be considered 3-D in enclosed spaces where the entire volume can be filled. These foams, however, have limited applicability to outdoor environments because of poor throw range and limited stability in windy conditions (Reference 6).

2. Dry Chemical Agents

Dry chemical agents fall into the category of heterogeneous chemical fire extinguishants. These powders are, for the most part, salts of the alkali metals and ammonia. There are four theories for the mechanism by which these salts extinguish fires:

a. The alkali metal carbonates decompose to give local blanketing by liberated CO_2 . However McCamy, et al. showed that for NaHCO_3 , less than 4 percent of the available CO_2 was liberated in their fire-extinguishing experiments (Reference 9).

b. The inhibition is due to reaction of the alkali metal with hydroxide ion thus inhibiting the associated chain branching mechanism (Reference 10). This is supported by the fact that the order of effectiveness in flame inhibition is $\text{K} > \text{Na} > \text{Li}$.

c. The reactive radical species are deactivated by collision with the particle surface (Reference 3, 4, 10). This is supported by the fact that there is a strong dependence between particle size and flame inhibition (Reference 4), and the fact that Monnex^R, which decrepitates in a flame, has been shown to be superior in some instances to KHCO_3 (Purple K Powder, PKP) (Reference 3, 4).

d. The chemical reactions associated with vaporization, decomposition, dissociation, etc. form endothermic reaction sinks to effectively remove heat from the reaction, thus inhibiting flame propagation (Reference 10, 11).

In general, dry chemical agents have been shown to be effective 3-D fire extinguishants (Reference 3, 4). Associated with dry chemical agents are

problems with poor throw range, poor performance in windy conditions, corrosion, visibility, and cleanup. If these agents are to be effective 3-D agents, the above problems must be overcome.

3. Halons

Halons are homogeneous fire suppressants. Their mechanism of extinguishment is through the competitive inhibition of free-radical chain branching reactions in the combustion reaction (Reference 3, 12, 13). An alternative mechanism has been proposed whereby the halons inhibit the flame through heat absorption processes (Reference 11). Halons are halogenated hydrocarbons of the Freon family, and, in general, only three of these compounds are now used as extinguishing agents: CF_3Br (Halon 1301), CF_2ClBr (Halon 1211), and $\text{C}_2\text{F}_4\text{Br}_2$ (Halon 2402).

The physical characteristics of each of the compounds has much to do with their 3-D fire extinguishing capabilities. Because Halon 1301 is expelled as a gas and mixes well with the air, it has extremely good 3-D capabilities in enclosed spaces. But because it is a gas, it is subject to drafts and wind and, therefore, cannot be considered for outdoor use or even hand-extinguisher application (Reference 14). It is, however, used quite successfully in total flooding situations.

Halon 1211 is expelled predominantly as a liquid and quickly becomes gaseous. Because of the liquid component, Halon 1211 has some flame-penetration ability, as well as directability of throw. Although the range of throw is limited, Halon 1211 is currently the primary auxiliary agent aboard aircraft crash rescue vehicles because of its cleanliness and low toxicity. Since 1211 only has limited liquid characteristics it is not reliable in an outdoor environment and has extremely limited fuel inertion capabilities; therefore, the fuel spill is susceptible to flashbacks. These facts make 1211 a less desirable 3-D fire-extinguishing agent for outdoor application.

Halon 2402 is expelled as a liquid with a boiling point of 117°F and stays liquid until it is within the fire zone. This characteristic gives

Halon 2402 good throw and direction. Halon 2402 will penetrate the flame front and even the fuel surface, temporarily making the fuel inert. This means that there is an increased 3-D characteristic over either 1211 or 1301 for outdoor application and less danger of flashback. An increased toxicity level is associated with Halon 2402 and needs further definition before this agent can be considered acceptable for general Air Force/Navy use.

B. MULTICOMPONENT AGENTS

1. Halon-Aspirated Foams

This process involves the entrainment of Halon vapor, usually 1301 into the foam bubbles of Aqueous Film-Forming Foam (AFFF). This is done primarily to give an inerting atmosphere inside the bubbles of the foam, to be released as the foam bubbles break, creating an inert, rather than an oxidizing, atmosphere. The hardware for such a system is patented by Grumman Aerospace and its use as specified in the patent results in a 5-percent entrainment by volume of Halon 1301 into AFFF solution (Reference 15). Although this process might improve the performance of the foam, the 3-D characteristics may not be effected (tests conducted by Naval Research Laboratories, NRL, showed no improvement over AFFF in the extinguishment of a 50-foot diameter JP-5 fire). The extinguishment mechanism of halon-aspirated foam still depends on blanket integrity; there is no significant concentration of Halon 1301 above the foam layer. There may be an increase in foam throw range and expansion ratio; however, this has not been quantified outside of the patent claims.

2. Halon Foams

This process involves the making of a foam solution of concentrate with a significant amount of halon and was first investigated by A.D. Little (Reference 16). The solution developed was a nonaqueous foam with marginal foam quality. In addition, this concept takes a homogeneous agent with 3-D character and makes it a blanketing agent with poorer cooling characteristics, no 3-dimensionality (i.e., no significant Halon

concentration above the foam blanket (Reference 17)) and questionable toxicity.

Recently RTG company in Germany has developed a Halofoam^R. This foam is composed of a mixture of Halons 2330 and 2420 in standard AFFF (Reference 18). This foam, which comes as a concentrate to be mixed in a 15/85 mixture of concentrate to water, is claimed to be an improvement over normal AFFF. The foam is expelled as a nonaspirated liquid, which quickly foams in the fire zone as the halon is evaporated. Although the report was unavailable to the authors of this subtask report, the German army has evaluated this foam, and reportedly found it superior to AFFF in some respects. Two possible reasons for this foam's superiority are: (1) the entrainment of an inert atmosphere inside the foam structure and (2) the formation by this foam of highly stable small uniform bubbles. Reference 18 claims that this foam can also cling to vertical surfaces. In addition, this material is claimed to have an increased throw range and improved sealability over AFFF.

3. Halonite

Halonite is a patented mixture of Halon 1301 and Halon 1211 marketed in the U.S. by ASP company (Reference 19). The agent has been tested by Factory Mutual Research and found to be 50 percent more effective than either Halon 1301 or Halon 1211 alone (Reference 20) in a 50:50 mixture. Reference 20 claims that the increased improvement is because of (1) better throw or penetration (over Halon 1301), (2) longer residence time in the flame zone, and (3) possible changes in key flame-inhibiting chemical reactions relative to the pure agents. Although the agent is reported to have increased firefighting ability, one would not expect its performance to be improved over 1211 against an outdoor 3-D liquid fuel fire because of the gaseous nature of the agent.

4. Dual-Agent Application

The theory behind dual-agent application of halon or dry chemical with foam is to incorporate the 3-D characteristics of halon or dry chemical

agents with the surface inertion characteristics of foam, as investigated by Geyer (Reference 3). This method, although effective, is still plagued by the individual agent problems combined with the cumbersome handling and/or coordination of two nozzles. Geyer (Reference 3) found a destructive interference between 1211 and PKP in a dual agent application. Acid may also form and lead to corrosion when Halon 1211 is combined with AFFF.

SECTION III

APPARATUS DEVELOPMENT

To further evaluate some of the agents discussed in Section II as well as characterize a 3-D fire, a suitable apparatus was built. The goals of the construction were: (1) that the apparatus be practical and (2) that it give accurate baseline results regarding agent capabilities. It was decided that to reach this goal a stepwise progression from a running-fuel fire to a 3-D fire was necessary.

The design for the running-fuel fire was similar to that used by Geyer in his inclined-plane studies (Reference 3). The actual apparatus shown in Figure 1 is 2/5 the size of Geyer's with a 5° slope on the ramp. This slope is greater than the approximately 1° slope of an Air Force runway but allows for a consistent flow and conservative evaluation of agents. The fuel at the top flows over a weir to give an even flow of fuel down the incline.

The ramp is cooled by a water spray underneath to minimize warpage. The pan is buried in the ground so that heat is removed from the metal, thereby, making the use of water to float the fuel unnecessary. This apparatus was used to characterize the running-fuel fire and to do some initial agent-scoping studies discussed in Sections IV and V.

Upon completion of the test matrix for the running-fuel fire the apparatus was modified to include a cascading fire. This was accomplished to simulate the post-crash scenario where fuel is cascading onto an inclined runway and then pooling elsewhere. It was felt that a cascade apparatus such as described in Reference 2 would not allow the proper airflow characteristics and would give the agent a backboard off of which to bounce. Since the performance of current agents depends on these variables it was determined that such an apparatus would not give practical baseline results regarding agent capabilities. The resulting apparatus, shown in Figure 2, consists of the fuel flowing over a weir, down a wire screen and down the ramp. Additional splash guards (not shown) kept the fuel from splashing off the ramp and onto the ground. These splash guards were at 45-degree angles to the cascade element to minimize reradiation effects. The purpose of

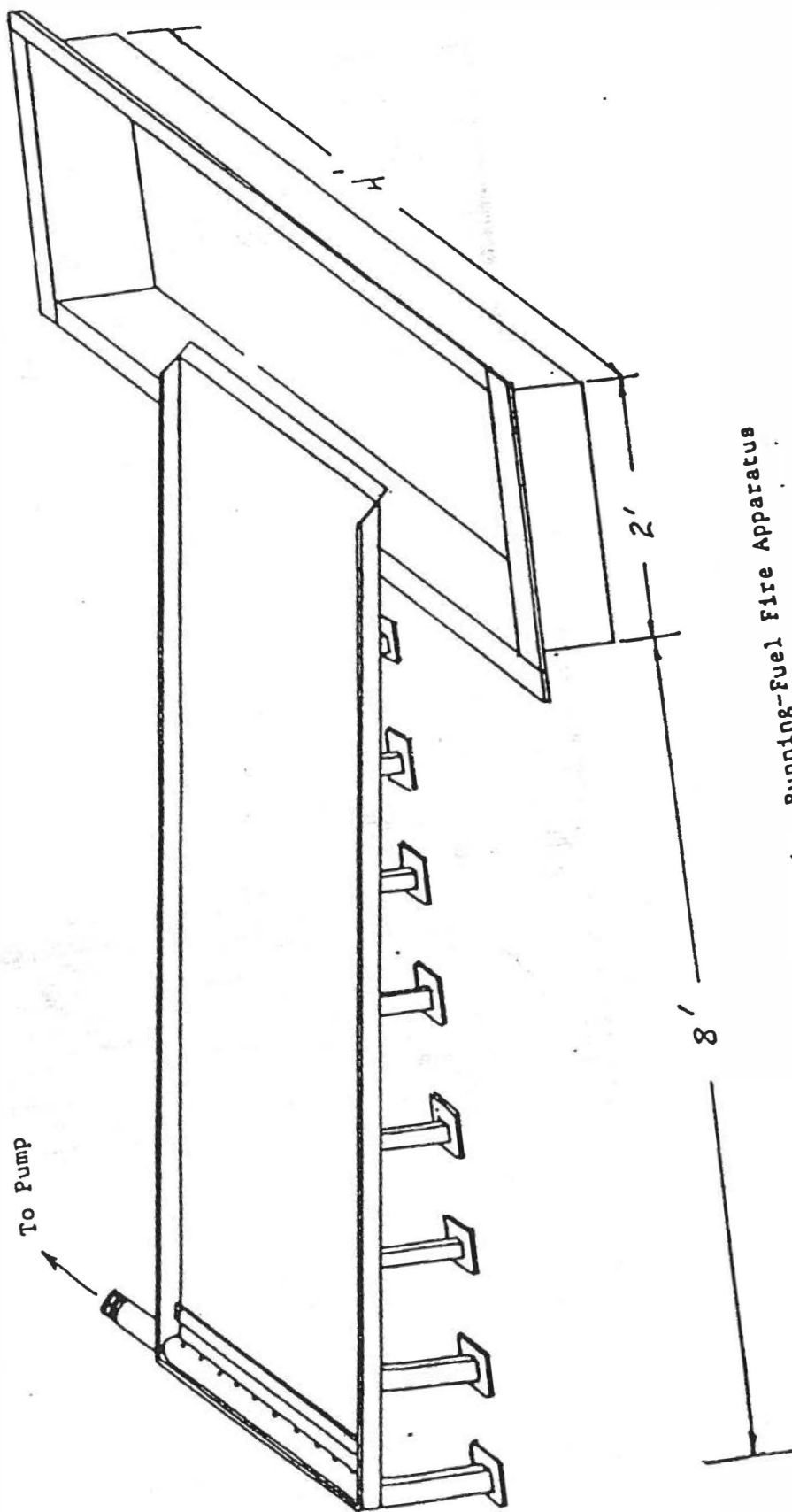

Figure 1. Running-Fuel Fire Apparatus

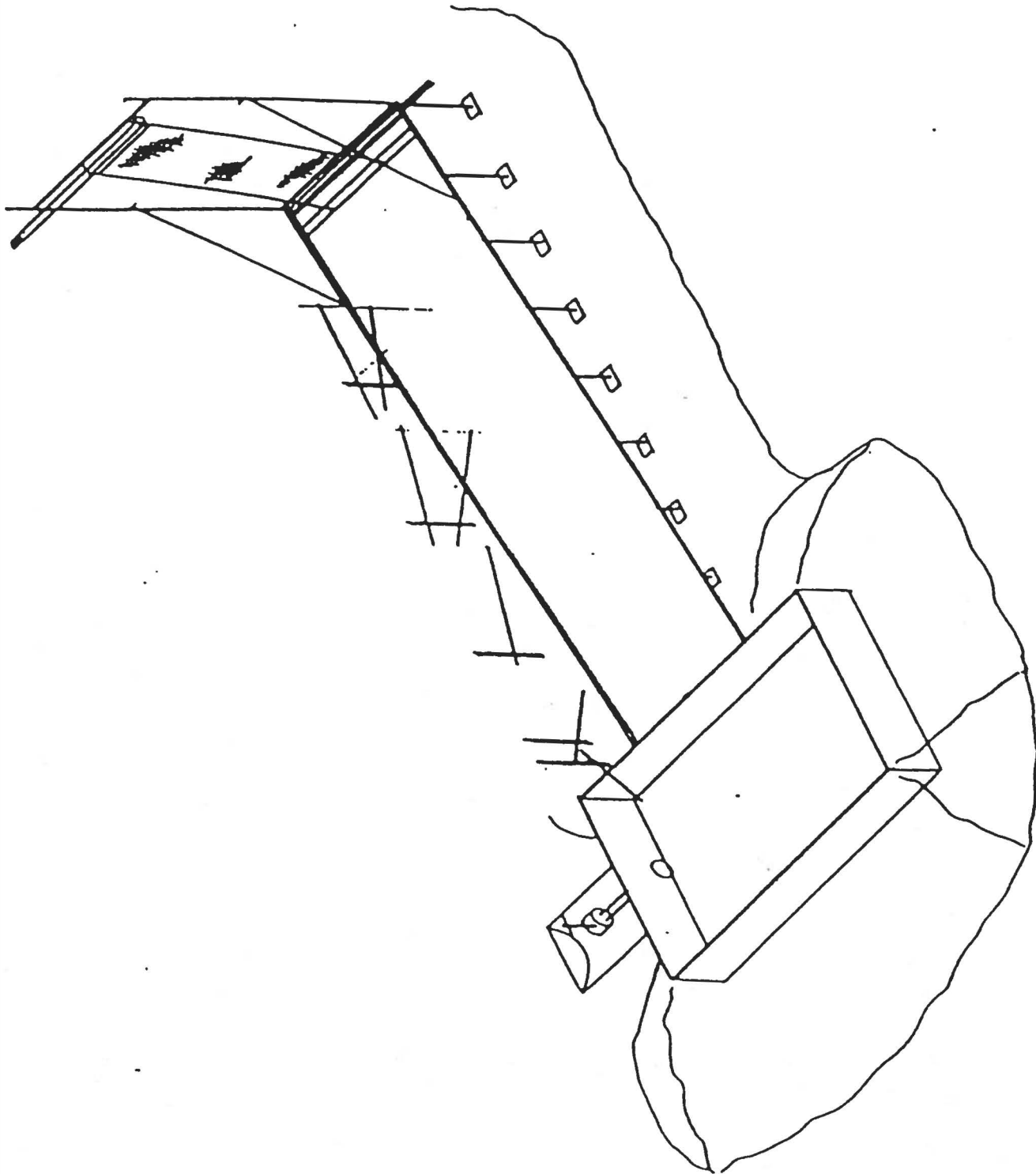

Figure 2. 3-D Small-scale Agent-Scoping Apparatus

Fig 1

Fig²

the wire screen was to direct the flow of fuel while maintaining realistic air flow.

A qualitative indication of the repeatability of the fire on this apparatus is shown in Figure 3 with both the pictures being taken on different days but at the same general point in the fire (40-45 seconds into the preburn). This will be discussed quantitatively in Section V. This apparatus was then used to characterize a 3-D fire and in agent-scoping studies to be discussed in the next two sections.



3-A



3-B

Figure 3. Photographs Showing Repeatability of Agent-Scoping Apparatus

Fig³

SECTION IV
AGENT-SCOPING STUDIES

A. 2-D RUNNING-FUEL FIRE

Using the apparatus shown in Figure 1, several different agents were scoped for their effectiveness against a 2-D running-fuel fire. All studies were conducted in winds of less than 10 mph. The agents were applied by first approaching the pan, then attempting the extinguishment of the ramp and cascade - an approach considered to be both realistic and representative of worst-case. Criteria for extinguishment were based on a limited amount of agent, scaled to the apparatus. The results of these studies are presented in the following paragraphs.

1. Halon 1211

Halon 1211 (Table 1) did not successfully extinguish the fire in seven of eleven trials. In all tests a wheeled CB Unit (Fire Guard model FEU 1/m), used to containerize the Halon 1211, was pressurized to 150 psi. The Halon 1211 performance depended on the conditions of the test and did not extinguish any fire in winds greater than 2 mph. The performance of Halon 1211 also seemed to depend on the nozzle used, with the Akron Brass Turbo Jet nozzle outperforming the standard-issue nozzle on the P-13.

2. Halon 2402

Halon 2402 (Table 2) extinguished the fire in all cases, both in windy (>5 mph) and calm conditions. The 2402 was containerized in a 40-pound, hand-held unit pressurized to 150 psi with a 3 lb/sec. straight-tip nozzle. The success of the Halon 2402 is partially because of its ability to temporarily make the fuel inert leading to decreased flashback danger.

TABLE 1. HALON 1211 EFFECTIVENESS ON 2-D RUNNING-FUEL FIRE

JP-4 flow rate, gpm	Preburn time, min	Agent, lbs	Extinguishment time, sec
8	1	22.6 ^a	29
8	1	129.8 ^a	60.6
8	1	129.8 ^a	75
8	1	50.6	23.7
8	1	129 ^a	53
8	1	25.2	11.8
4	1	129.8 ^a	52.4
4	1	27.5	13.6
8	2	21	10.4
8	2	122 ^a	50.2
4	2	119 ^a	64

^aThe fire was not extinguished.

TABLE 2. HALON 2402 EFFECTIVENESS ON 2-D RUNNING-FUEL FIRE

JP-4 flow rate, gpm	Preburn time, min	Agent, lbs	Extinguishment time, sec
8	1	17.5	9
8	1	17.25	7.2
8	1	16	4
4	1	11.25	4.4
4	1	10.3	5.5
8	2	29.5	12.1
8	2	43	19
8	2	11	4.8
8	2	11 ^a	6
4	2	14.5	6.4
4	2	11.5	4.3
4	2	30.3 ^b	14.4

^aApplied after PKP failed.

^bApplied after 1211 failed.

3. 6-Percent AFFF

6-percent AFFF (Table 3) did not extinguish the fire in 4 out of 5 attempts. The AFFF was containerized in a wheeled CB Unit, pressurized continuously at 150 psi, and delivered through an air-aspirating nozzle.

4. 3-Percent AFFF

3-percent AFFF (Table 4) was not effective in extinguishing the fire. The AFFF was containerized in a wheeled CB unit, pressurized continuously at 150 psi and delivered through an air-aspirating nozzle in two out of three attempts. In one attempt, an Akron Brass Turbojet nozzle was used with nonaspirated foam. The nonaspirated foam was least effective at controlling the fire. This was probably because of the lack of bubble structure, which helps provide some surface inertion ability as the foam "stacks-up."

5. Dual-Agent Application

Dual-agent application (Table 5) of PKP and 6-percent AFFF through an Ansul dual-agent nozzle was effective in extinguishing the fire in all cases. Both the PKP and 6-percent AFFF were contained in wheeled CB Units with a continuous pressure of 150 psi. The technique employed in three out of four tests was to hold both triggers open, allowing the foam to extinguish the pan fire and letting the PKP extinguish the ramp.

Dual-agent application (Table 6) of Halon 1211 and 6-percent AFFF through the Ansul nozzle extinguished the fire in all cases. The extinguishment with Halon 1211/AFFF took less average time than that with PKP/AFFF.

The single dual-agent nozzle was used so that one person could extinguish the fire; however, this approach is cumbersome and wastes the agent.

TABLE 3. 6-PERCENT AFFF EFFECTIVENESS ON 2-D RUNNING-FUEL FIRE^a.

JP-4 flow rate, gpm	Agent, lbs	Extinguishment time, sec
8	94 ^b	25
8	114 ^b	39.5
8	77 ^b	82
4	133.5	34
4	146.7 ^b	80

^a1-minute preburn.

^bFire was not extinguished.

TABLE 4. EFFECTIVENESS OF 3-PERCENT AFFF ON 2-D RUNNING-FUEL FIRE.^a

JP-4 flow rate, gpm	Agent, lbs	Extinguishment time, sec
8	93.5 ^b	28
4	77.5 ^b	21
4	112 ^b	67 ^c

^a1-minute preburn.

^bFire was not extinguished.

^cA nonaspirating nozzle was used.

TABLE 5. DUAL-AGENT APPLICATION EFFECTIVENESS OF 6-PERCENT AFFF/PKP ON 2-D RUNNING-FUEL FIRE^a

JP-4 flow rate, gpm	Agent, lbs		Extinguishment time, sec
	PKP	AFFF	
8 ^b	30.5	84	38.1
8	51.5	128	33
4	42.5	44.5	11
4	60.5	49.5	6

^a1-minute preburn.

^bUsing alternating triggers on dual-agent nozzle.

TABLE 6. EFFECTIVENESS OF DUAL-AGENT APPLICATION OF HALON 1211 AND 3-PERCENT AFFF ON 2-D RUNNING-FUEL FIRE.^a

JP-4 flow rate, gpm	Agent, lbs		Extinguishment time, sec
	1211	AFFF	
4	88.5	15.0	9
4	4	42	8

^a1-minute preburn.

6. Combination Agent Halon 1211 and Halon 2402

A combination of Halon 1211 and Halon 2402 was used to extinguish the fire, and accomplish three objectives: (1) reduce the cost of agent used, (2) reduce the toxicity of Halon 2402, and (3) improve the three-dimensionality of the Halon 2402 by adding a more gaseous agent while retaining the same firefighting characteristics.

The data shown in Table 7 point to a decreasing effectiveness of the agent as the amount of Halon 1211 increases. This is because the agent becomes more susceptible to the effects of wind as the percentage of the more gaseous Halon 1211 increases. The 75 percent Halon 2402:25 percent Halon 1211 mixture did show increased performance over even the pure Halon 2402. Increased throw range and three-dimensional character was observed. The combination agent was contained in a 40-pound hand-held extinguisher pressurized to 150 psi and using a 3 gpm straight pipe aluminum nozzle (length = 3 inches, i.d. = 0.75 inches). The approach for this agent is similar to that used for the Halonite discussed earlier, but with an increased liquid component, the Liquilon^R agent (75 percent Halon 2402:25 percent Halon 1211, patent application submitted) yields better throw and flame-penetrating ability.

B. 2-D AGENT-SCOPING SUMMARY

The following general concepts were developed as a result of the evaluation of agent effectiveness against a 2-D running-fuel fire:

1. The ability of the agent to make the fuel inert is essential in regard to its three-dimensional ability. Since there is a constant new source of fuel if there is no inertion ability, flashback occurs from ignition sources such as the fuel contacting hot metal as the agent is directed toward the source of the fuel.

TABLE 7. COMBINATION AGENT HALON 1211/ HALON 2402 EFFECTIVENESS ON 2-D RUNNING-FUEL FIRE.^a

JP-4 flow rate, gpm	Agent, lbs	Extinguishment time, sec
25% 2402/75% 1211		
8	20.5	6
8	43.25 ^b	34
4	40.25 ^b	19
4	12.5	5
50% 2402/50% 1211		
8	31	22
8	41.5	42
8	42.5 ^b	29
4	11.5	3
4	10.5	3
75% 2402/25% 1211		
8	15.5	3
8	11	3
4	18	6
4	16.25	6

^a1-minute preburn.

^bFire was not extinguished.

2. An agent applied from the top of the ramp and allowed to flow with the fuel is more effective, because the flame structure is less developed at the fuel source and develops as the fuel flows down the pan.

3. Foams are ineffective on this apparatus.

4. Halon 1211, although quite effective in quiescent conditions, is not very effective in a windy environment.

5. Halon 2402 is effective in the extinguishment of a 3-D running-fuel fire, partially because of its ability to make the fuel temporarily inert.

6. The addition of 25 percent Halon 1211 to the Halon 2402 increases effectiveness by giving Halon 2402 better 3-D and wraparound characteristics.

7. Dual-agent applications, although effective, are cumbersome and make inefficient use of agents.

C. 3-D FIRE WITH CASCADE

Upon completion of the agent-scoping studies against a 2-D running-fuel fire the apparatus was modified to assess 3-D fire characteristics. Agent-scoping studies were then continued against the modified apparatus which included a cascading-fuel element. The criteria for extinguishment were based on a limited amount of agent, scaled to the apparatus. The results of these studies are as follows:

1. Halon 2402

Halon 2402 extinguished the fire in every case (Table 8). The ability of 2402 to combat a 3-D cascading-fuel fire is superior to that of any agent tested. The agent was discharged from a CB Unit with 150 psi of continuous pressure. The nozzle used was a straight-pipe brass nozzle (length = 4.75 inches, i.d. = 0.6 inches).

2. PKP

PKP did not extinguish the fire in any instance tested (Table 9), and the PKP clogged the hose in two of three instances. In the first test, the PKP was greatly influenced by wind. The agent was discharged through an Ansul powder nozzle using a CB Unit, which was constantly pressurized to 150 psi.

3. Dual-Agent

The effectiveness of dual-agent application was studied for halons in combination with foams and is shown in Tables 10 and 11. Halon 2402, in combination with AFFF, was superior to Halon 1211 with AFFF because its liquid characteristic enables it to penetrate the flame front and minimizes interferences by the foam. Halon 2402, in combination with foam is less efficient than Halon 2402 by itself. The advantage of the dual-agent approach is the longer surface inertion of the pool by the AFFF.

4. Combination Agent

The combination agent of Halon 1211/Halon 2402 developed in the running-fuel fire study was evaluated on the cascading apparatus (Table 12). The performance of this agent, considering extinguishment time and amount, was less than Halon 2402 against the cascading fire. This reduction in efficiency is probably caused by the increased buoyancy of the 3-D cascading fire. This makes the gaseous aspect of this agent more of a factor.

TABLE 8. EFFECTIVENESS OF HALON 2402 ON 3-D CASCADING-FUEL FIRE.

JP-4 flow rate, gpm	Agent, lbs	Extinguishment time, sec
7.0	36	7
2.8	74.5	13
2.8	32	4

TABLE 9. EFFECTIVENESS OF PKP ON 3-D CASCADING-FUEL FIRE.

JP-4 flow rate, gpm	Agent, lbs	Extinguishment time, sec
2.8 ^a	74	34
7.0 ^b	-	-
7.0 ^b	24.5	18

^aFire was not extinguished.

^bThe nozzle clogged.

TABLE 10. EFFECTIVENESS OF HALON 1211/AFFF ON 3-D CASCADING-FUEL FIRE.

JP-4 flow rate, gpm	Agent, lbs		Extinguishment time, sec
	1211	AFFF	
2.8	92.0	138	44.5
2.8	80.9	144.0	39
2.8	140.0	150.0	54
7.0	184.0	135.5	25

TABLE 11. EFFECTIVENESS OF HALON 2402/AFFF ON 3-D CASCADING-FUEL FIRE.

JP-4 flow rate, gpm	Agent, lbs		Extinguishment time, sec
	1211	AFFF	
2.8	86.7	87.0	38
7.0	90.2	136.5	29
7.0	74.5	151.0	38

TABLE 12. EFFECTIVENESS OF HALON 2402/1211 COMBINATION AGENT ON 3-D CASCADING-FUEL FIRE.

JP-4 flow rate, gpm	Agent, lbs	Extinguishment time, sec
2.8	84.6	15
7.0	123.5	14

5. Scaling

To evaluate the scaling of the agent amount for extinguishment of a 3-D fire, the effectiveness of the "best" agent (Halon 2402) was evaluated. It was first necessary to determine the average amount of agent necessary to extinguish a 1-D (2-foot x 4-foot pan), a 2-D running-fuel fire, and a 3-D cascading fire. The results of extinguishing tests of the 2-foot x 4-foot pan are shown in Table 13. A comparison of these results to those contained in Tables 2 and 8 shows an dramatic increase in required agent as a function of dimensionality. This relationship is shown in Figure 4.

TABLE 13. EXTINGUISHMENT OF 2-FOOT X 4-FOOT PAN FIRE BY 2402.

Agent, lbs	Extinguishment time, sec
4.0	3.6
7.8	7.0
9.2	5.0
5.0	3.0

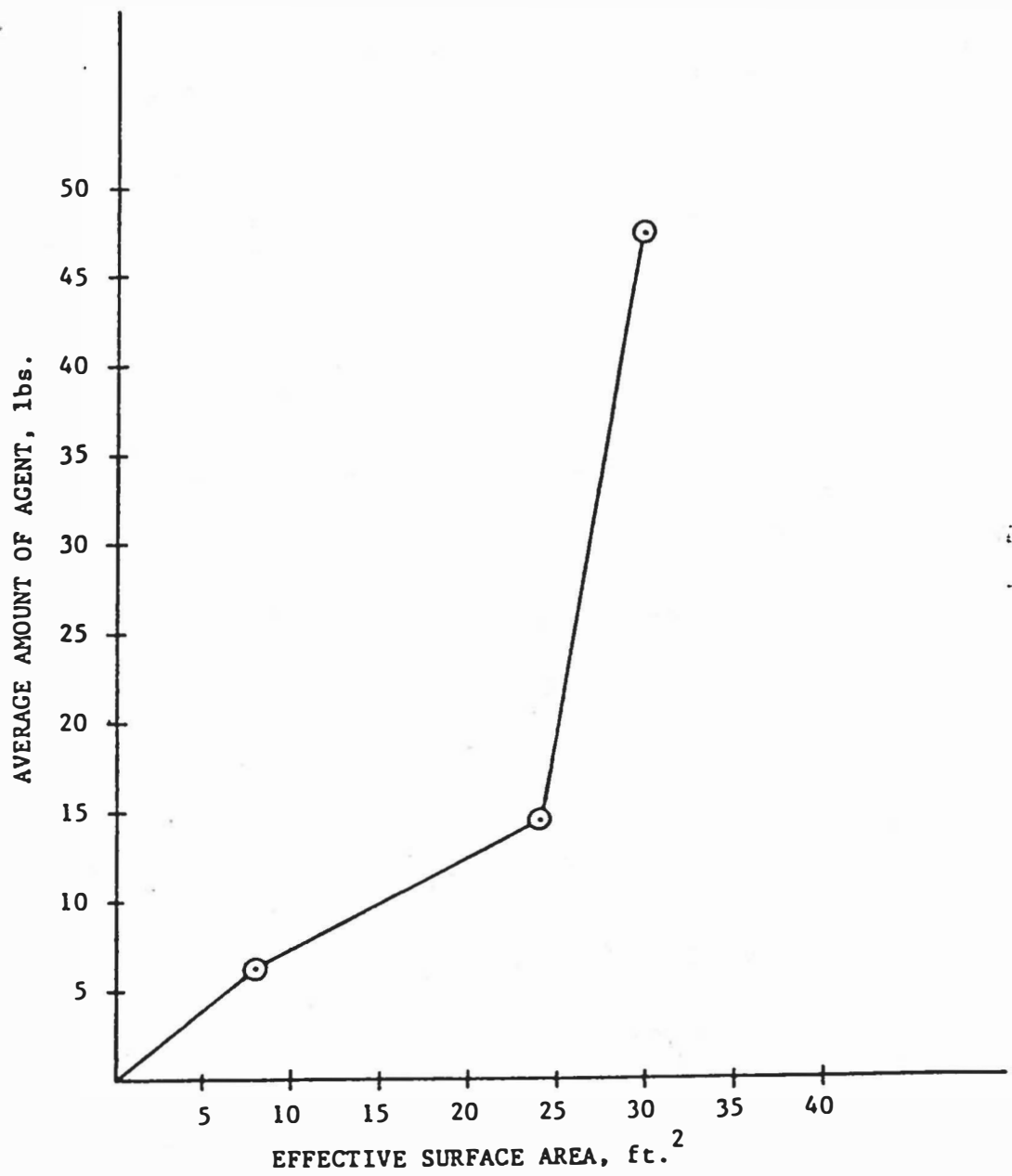

Figure 4. Amount of Agent (2402) Necessary for Extinguishment as a Function of Dimensionality.

f 8 cl

SECTION V
3-D FIRE CHARACTERIZATION

A characterization study of the 3-D fire was accomplished as part of the design and evaluation of the 3-D agent-scoping apparatus. The goals of this study were to better understand a 3-D fire and to develop a physical model based on this understanding. Predictions of burn rate for the cascading element have been attempted previously (Reference 1). Those authors concluded that there was a need to study the effects of a cascading or rod fire since most of the studies had been conducted on spray mists and pool fires. The authors made no attempt at correlating their mathematical description to experimental results.

The approach taken by the present study was to define a three-dimensional fire in terms of time, temperature, burn rate, and flame structure. This was done by using the apparatus developed as part of this study and described in Section III. Based on the results obtained in these experiments, a physical model was to be developed which would accurately predict the temperature profile for a given 3-D scenario. This temperature profile would then yield information to assist in defining the most efficient approach to extinguishing a 3-D fire.

A. EXPERIMENTAL

A series of burns was conducted, using the apparatus described in Section III. These burns were for 1, 2, and 3 minutes at two flow rates; low (3 to 4 gpm) and high (7 to 8 gpm), depending upon the apparatus. The fuel used was JP-4. Data were taken as a function of dimensionality: 1-D (a 2-foot x 4-foot pan), 2-D (running-fuel fire), and 3-D (cascading-fuel fire).

Time and temperature data were taken using eight thermocouple placements shown schematically in Figure 5. Five thermocouples (type k) were located 18 inches above the surface of the ramp at 2-foot intervals and above the center of the pan (Positions 00-04). In addition the top two positions (2-foot and 4-foot placements on the ramp) had thermocouples at 6 inches and 12

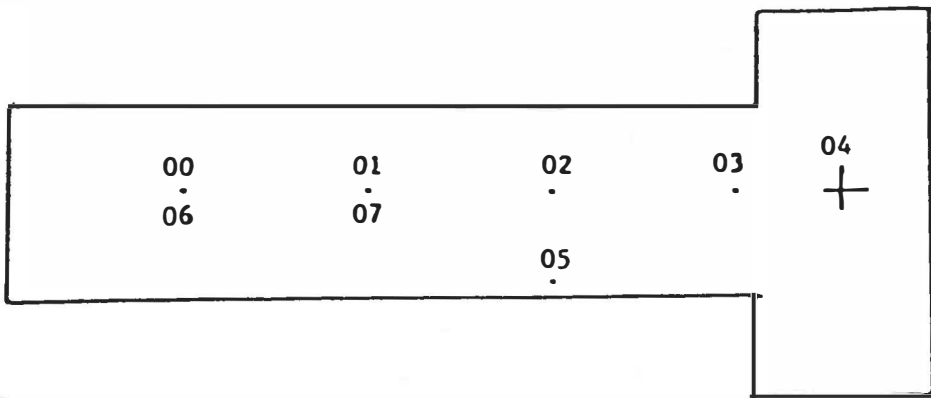

Figure 5. Thermocouple Placement in 3-D Scoping Apparatus. Placements are 18 inches Above Pan, Except 06 and 07, Which are at 6 inches and 12 inches, Respectively.

F'75

inches, respectively, (06 and 07). This was done to study the flame temperature at different regions of the flame. A thermocouple (05) was also placed 18 inches above the side of the ramp at the 6-foot placement in order to measure the flame temperature at the outside of the flame. This arrangement of thermocouples is shown pictorially in Figure 6, along with the apparatus. The output from the thermocouples was recorded, using a multichannel recorder with tape output. These data were fed into a computer, and graphed, and are presented in Appendix A.

The amount of fuel burned was determined by metering the amount of fuel pumped into the apparatus during the test and collecting the drained residue at the completion of the test. Flame height and structure were obtained from video recordings made of each test.

In each test the fuel was ignited as it started to flow over the weir, and allowed to burn for a specified time of 1, 2, or 3 minutes. At the end of this time the fuel flow was shut off and the fire was extinguished as quickly as possible (starting from the top of the pan) with Halon 1211 or 2402. All tests were conducted in winds less than 2 mph; however, all tests were conducted outdoors where short gusts and local induced winds caused by the burning fuel might have affected the test. The results of this study are summarized in Tables 14-16 and discussed in the next section.

B. Results and Discussion

1. Burn Rate

A strong dependence was observed between the dimensionality of the fire and the observed burn rate, as shown in Figure 7. In general, the burn rate is a function of the rate of vaporization of the fuel (i.e., JP-5 fires have a lower burn rate than JP-4 fires and thus are easier to extinguish). For a one-dimensional pool, this rate of vaporization limits itself at some finite diameter (1 meter) (Reference 21) as can be seen by examining the insert for Figure 7. In a flowing-fuel fire (running-, cascading-, or rod-fuel fire), the burn rate is related to:

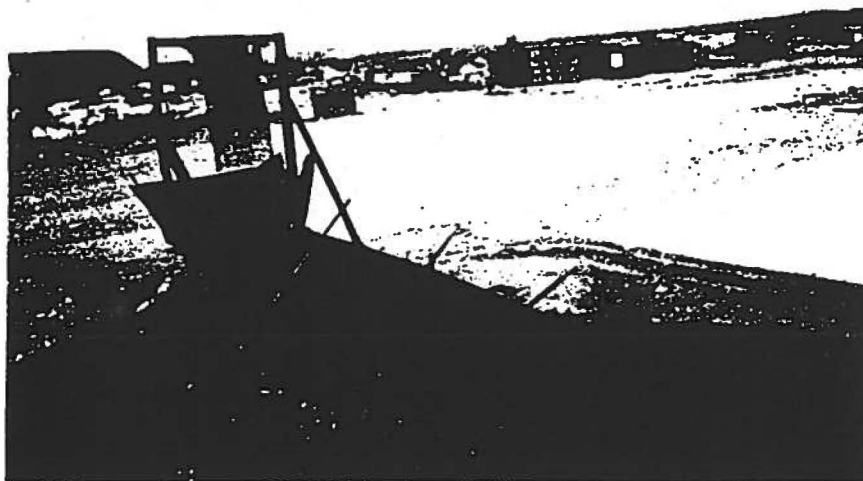

6-A

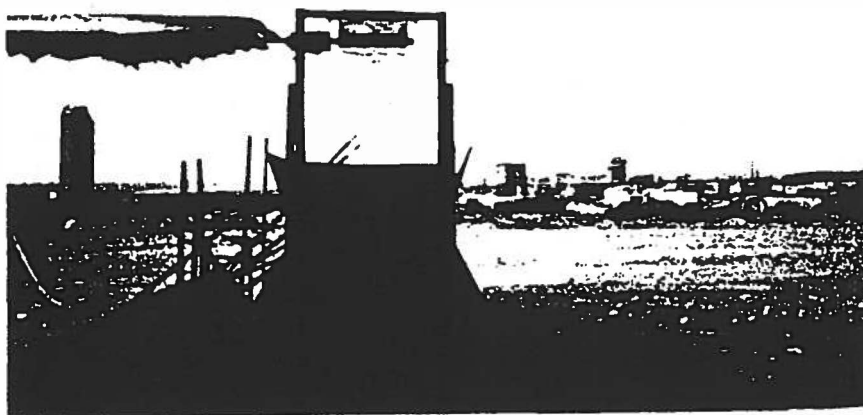

6-B

Figure 6. 3-D Small-scale Agent-Scoping Apparatus Showing Thermocouple Placements.

9.8⁶

TABLE 14. FIRE CHARACTERIZATION RESULTS FOR 2-FOOT X 4-FOOT PAN FIRE

Test #	Preburn, min	Burn rate, gpm	Tmax, F	Flame height above pan, ft
77	1	1.0	719	4.6
78	1	1.1	694	2.9
79	1	1.3	520	1.8
80	2	1.2	696	2.6
81	2	1.0	637	2.6
83	3	0.6	628	1.6
84	3	0.8	1668	1.6
85	3	1.0	1276	1.8

TABLE 15. FIRE CHARACTERIZATION RESULTS FOR RUNNING-FUEL FIRE

Test #	Flow rate, gpm	Preburn, min	Burn rate, gpm	Tmax, F	Flame height above pan, ft		
					Mid ramp	Top ramp	
45	4	1	2.5	1125	5.7	0.8	0.9
51	4	1	2.0	1684	8.8	2.1	0.2
63	4	1	2.0	954	2.0	4.9	1.7
46	8	1	2.4	561	5.6	0.9	0.2
53	8	1	2.5	1282	5.2	0.7	0.2
64	4	2	2.3	1263	5.3	1.0	0.7
65	4	2	2.1	1332	4.9	4.8	0.3
66	8	2	1.6	828	5.4	0.9	0.5
69	8	2	1.7	827	5.8	1.1	1.2
71	4	3	2.7	1265	1.4	2.6	1.4
72	4	3	2.75	1633	1.5	3.2	1.4
75	8	3	1.5	976	3.0	2.7	0.5
76	8	3	3.0	1665	9.21	2.4	0.8

TABLE 16. FIRE CHARACTERIZATION OF 3-D CASCADING-FUEL FIRE

Test #	Flow rate, gpm	Preburn, min	Burn rate, gpm	Tmax, F	Flame height above pan, ft		
					Pan	Ramp	Cascade
95	3.0	1	3.0	880	4.3	1.8	8.0
96	3.0	1	3.0	1192	1.9	3.9	3.4
97	3.0	1	3.0	839	0.7	1.5	3.9
98	3.0	1	3.0	1546	0.7	4.0	4.67
105	7.0	1	4.0	1020	1.2	5.7	5.7
110	7.0	1	2.4	733	0.9	5.5	5.0
100	3.0	2	3.0	1287	4.7	7.8	3.0
101	3.0	2	3.0	1375	1.8	8.5	7.5
102	3.0	2	3.0	1280	1.8	2.3	6.0
109	7.0	2	4.2	1300	1.8	4.6	9.3
111	7.0	2	3.7	1603	1.1	3.4	8.2
113	7.0	2	4.1	1671	8.0	5.2	5.7
103	3.0	3	3.0	1201	2.0	4.6	7.5
115	3.0	3	3.0	1021	1.3	5.8	1.7
114	7.0	3	3.9	1645	4.5	0.9	8.9
116	7.0	3	5.8	1805	5.0	8.9	3.6

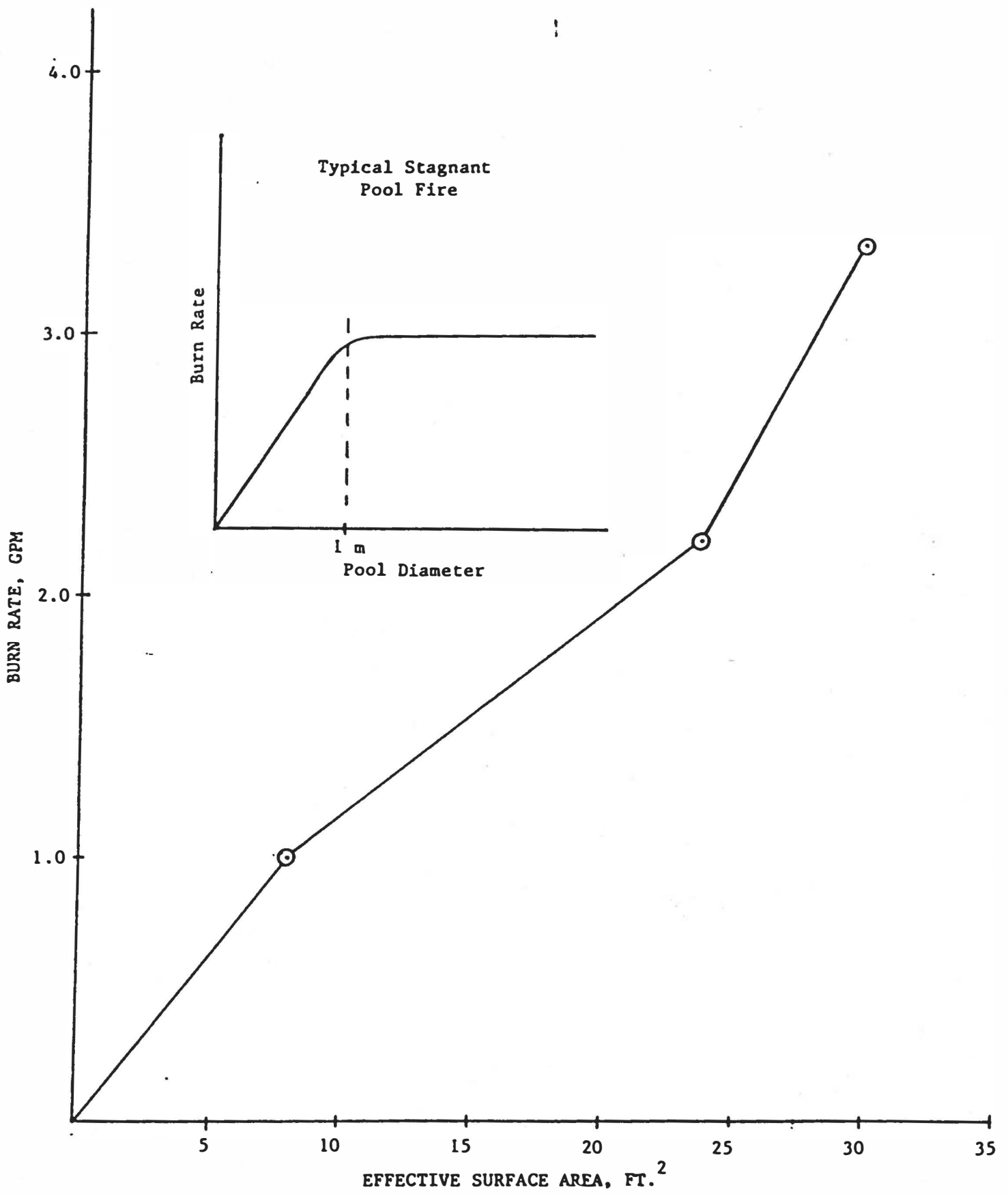

Figure 7. Effect of Dimensionality on Burn Rate.

Fig 1

$$\frac{H_1 - H_2 - H_3}{H_4}$$

Where H_1 is equal to the heat feedback into the fuel from the combustion zone, H_2 is equal to the heat carried away by the flowing fuel, H_3 is equal to the heat lost from the fuel to the environment, and H_4 is equal to the heat of vaporization of the fuel. The effect of wind, the effect of angle of flow, and fuel surface effects (those effects related to the type of liquid fuel flow, i.e., laminar vs turbulent flow, or the amount of droplet formation) influence the burn rate and are described in Reference 1.

The change in burn rate as a function of dimensionality (described by changes in plate angle in Reference 1) observed in this study are much greater than those found earlier (Reference 1). This could be caused by; (1) an increase in burn rate from the more realistic air-flow conditions of the apparatus developed as part of this study, or (2) a synergistic effect between the cascading element and the running-fuel fire (a multisource effect). These findings warrant further, more basic, study since the amount of agent used is also a function of burn rate for chemical agents.

2. Flame Structure

The flame structure also varied as a function of dimensionality. Two variations in flame structure were observed for the running-fuel fire. First, there was an increase in flame height as the flame front moved down the ramp (this is seen in Table 15 and in the average flame heights of 0.8 feet, 2.1 feet, and 4.8 feet for the top of the ramp, center of the ramp, and center of the pan, respectively). This was a function of the degree of development of the fire as it came down the ramp. Because the flame structure was less developed at the top of the ramp (source of the fuel), the fire was easier to extinguish if the agent was applied from the top of the ramp. Second, the average flame height for the lower fuel flow rate was greater than for the 8-gpm flow rate. This was probably because the thicker fuel layer, at the higher flow rate, insulated the fuel surface from pan reradiation, thereby causing a fire that was cooler and less buoyant. This also influenced agent performance since the halons' actions depend on their

ability to penetrate the flame front and on their degree of disassociation, which is temperature-dependent.

The primary influence of a 3-D fire on flame structure is seen in the instability of the flame structure at the fuel source. This instability was observed as a tendency of the flame to break away from the fuel flow at the source. In addition to the flame instability, there was a merging of the two highest flame regions (above the cascade and above the center of the pan) to a position toward the center of the ramp. This merging, however, was not a stable phenomenon.

3. Temperature

The running-fuel fire showed a definite difference in flame temperature between the ramp region and the pan region of the apparatus. Figure 8 shows this as a difference between the temperature readings for thermocouples 02, 03, and 04, and the readings for the other thermocouple positions. This difference is from heat loss as a function of the flowing fuel. Differences in the flame temperatures were not as evident for the cascading fire since the increased air flow around the cascading element causes an increase in flame temperature. In general, there are no trends in flame temperature with dimensionality. The range of maximum flame temperatures is quite broad and seems to be independent of any single variable. This phenomenon has been observed earlier (Reference 2). The correlation of time-temperature data did reveal that the fire of the 3-D apparatus stabilized in approximately 35 seconds. This stabilization time was independent of the dimensionality of the fire, as shown in the figures contained in Appendix A.

4. Computer Modeling

As part of this effort, attempts were made to develop a computer model which would accurately predict the behavior of a three-dimensional fire. These attempts failed, however, to predict the large variations in flame temperature, as well as the position-dependent variations in temperature. This inability to accurately predict flame temperatures can be

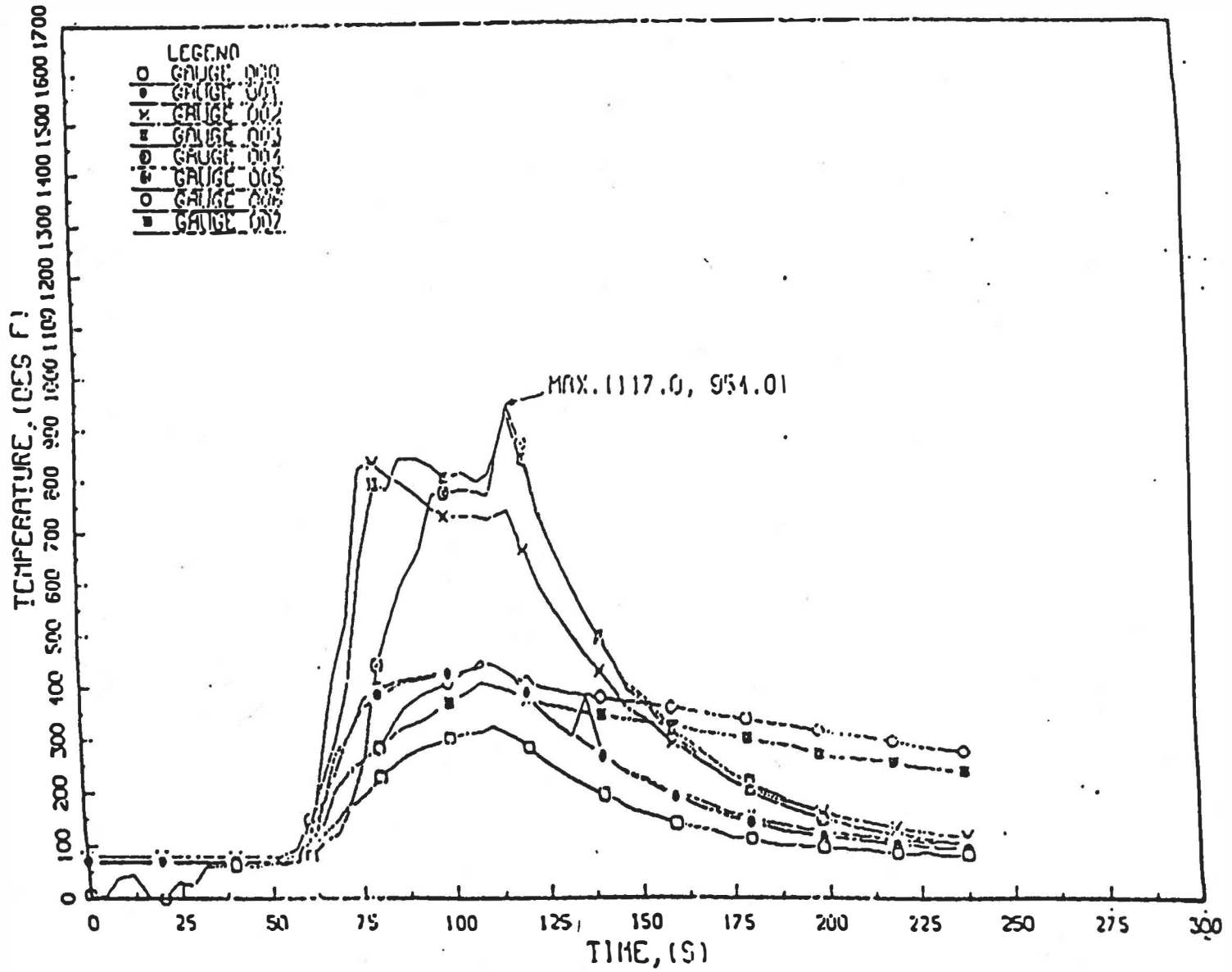

Figure 8. Actual Time-Temperature Results of a 3-D Test Fire.

Figs

seen in a comparison of Figure 9 with those Figures in Appendix A for three-dimensional fires. The inability to predict the behavior of these fires is due to (1) the large unpredictable variations in flame temperature and (2) the multisource effect of the cascade fire on the pool fire. There is still a need to be able to predict the behavior of three-dimensional fuel fires because the performance of any chemical agent will be depend on the flame temperature. Future attempts at modeling should be directed toward a more fundamental study.

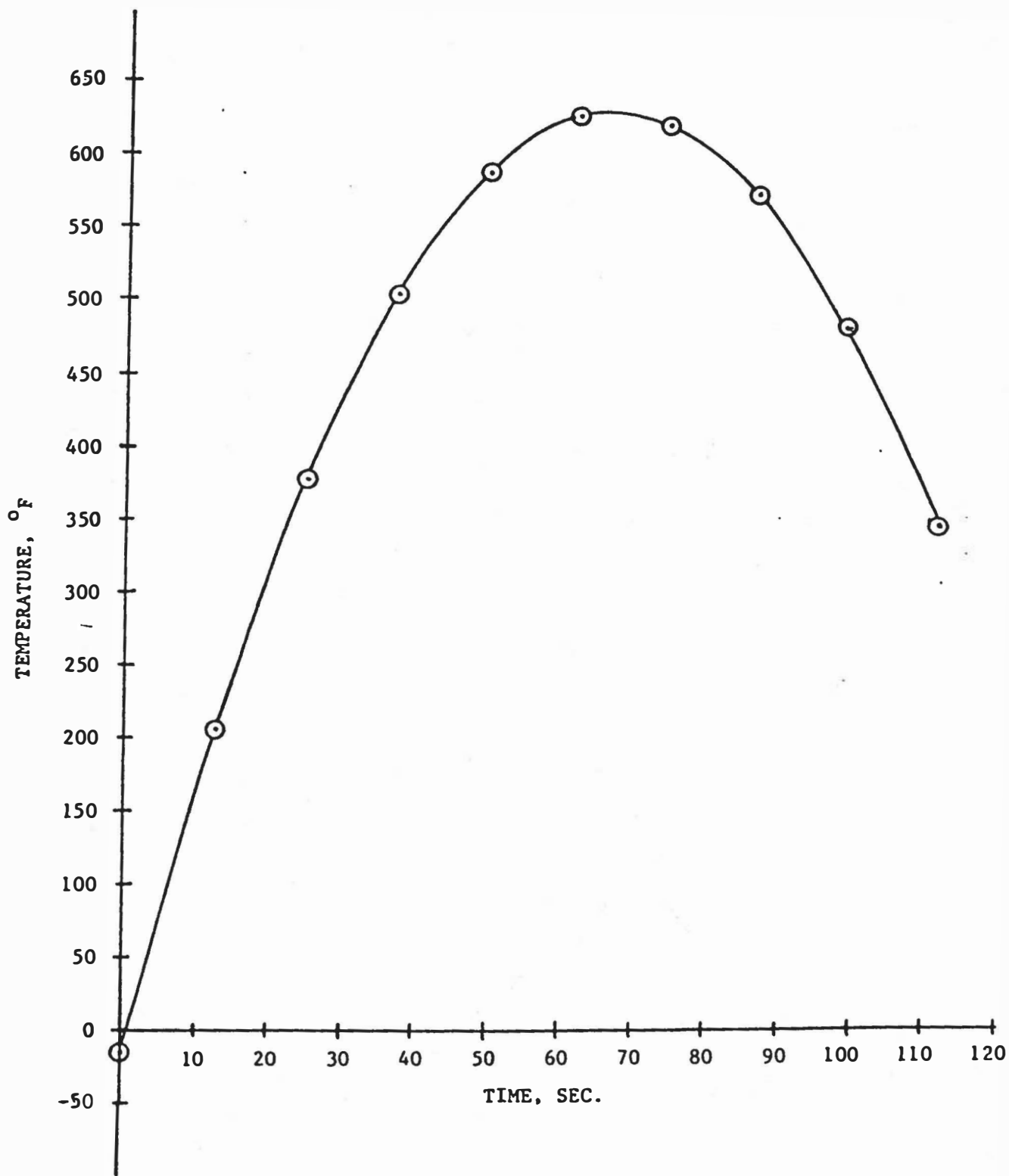

Figure 9. Plot of Time vs Temperature Based on Results of Computer Model.

Fig⁹

SECTION VI
CONCLUSIONS AND RECOMMENDATIONS

This phase of the subtask involved the development of a realistic and practical apparatus which would simulate a small-scale, three-dimensional fire scenario. The apparatus developed was then used to evaluate three-dimensional capabilities of existing agents. In addition, the apparatus was used to characterize the resulting 3-D fire in terms of burn rate, temperature, and flame structure, and attempts were made to develop a physical computer model to describe the fire. The following conclusions are offered.

A. CONCLUSIONS

1. Apparatus:

a. The apparatus developed as part of this effort repeatably simulates a 3-D fire scenario. The apparatus is practical, and may be used for small-scale agent-scoping studies; however, attention must be paid to the scaling of the agent to be scoped to the apparatus. The design of the developed apparatus is such that it may be incorporated as a standard agent evaluation test or as a firefighter training aid for the Air Force/Navy.

b. The developed apparatus simulates a cascading fire with a realistic airflow which allows for an accurate estimation of an agents capabilities. The present small-scale agent-scoping apparatus does not have a "backboard" off of which the agent may rebound and heat may reradiate.

c. The apparatus developed incorporates three aspects of a three-dimensional fire: (1) a flowing fuel cascade, (2) a running-fuel fire down an inclined plane, and (3) a stagnant pool fire. The apparatus is large enough such that a turbulent diffusion flame exists.

2. Fire Characterization Studies

a. There is a strong dependence between the dimensionality of the fire and the burn rate. This dependence is greater than that predicted in earlier studies (Reference 1). This dependence could be caused by either a more realistic air flow than in previous studies or by a "multisource effect" of the cascading element on the flowing fuel or pan fires. The result of this dependence is that critical application rates developed using one-dimensional pool fires may not be accurate for fuel fires of higher dimension.

b. Running-fuel fires demonstrated an increase in flame height as the fire developed down the inclined plane. This was primarily a function of the degree of flame structure development, with the fire at the fuel source being the least stable.

c. Flame instability was also observed in the cascading-fuel fire as a breaking off of the flame from the cascading element, and a merging of the flame structure over the center of the apparatus.

d. Based on time-temperature data the fire stabilized in approximately 35 seconds; therefore, in agent-scoping studies using the developed apparatus at least a 35-second preburn should be used before the agent is applied.

e. Because of large, unpredictable variations in temperature and a "multisource effect," the development of an accurate computer model for predicting flame temperatures and other characteristics of a 3-D fire was not accomplished.

3. Agent-Scoping Studies

a. The ability of the agent to make the fuel inert is critical to its three-dimensional capabilities, because there is a constant new source of fuel. If the agent has no fuel-inertion abilities, flashback occurs from ignition sources such as hot metal or as the area of agent application is varied.

b. Extinguishment is more efficient if the agent is applied from the fuel source (top of the ramp or cascade) and allowed to flow with the fuel. This is because the flame structure is less developed at the fuel source. This implies that the most efficient way to extinguish a 3-D fuel fire is to attack the fire at the fuel source.

c. Foams, which were designed as one dimensional agents for pool fires, are ineffective on the developed apparatus. Foams do inert the fuel surface of the pool fire and provide cooling to the surrounding environment, two qualities important to the effective extinguishment of fuel fires. Because of the effectiveness of foams in the extinguishment of fire, they are still currently the best choice of primary firefighting agent.

d. Halon 1211, although effective in quiescent conditions, is not reliable in an outdoor environment because of its large gaseous component. To increase the effectiveness of Halon 1211, the liquid component should be increased so that the agent is not so susceptible to wind effects and convection effects from the fire.

e. Dry chemical agents are effective in the extinguishment of three-dimensional fires; however, the problems associated with throw range, wind effects, packing of the agent in hoses, visibility, and cleanup must be overcome.

f. Dual-agent applications, although effective in the extinguishment of 3-D fuel fires, are cumbersome and tend to apply the individual agents in an inefficient manner. Any dual-agent application designed for use by the Air Force/Navy needs to consider the most efficient application of the individual agents.

g. Halon 2402 is effective in the extinguishment of a 3-D fuel fire, because it is primarily a liquid, giving Halon 2402 increased throw, direction, and flame penetrating ability over other halons, and because of its ability to temporarily make the fuel inert.

h. The addition of 25 percent Halon 1211 to the Halon 2402 increases its effectiveness on a running-fuel fire; however, for the cascading-fuel fire the fire's increased buoyancy lowers the effectiveness of this agent because of the increased gaseous component of this agent over pure liquid Halon 2402.

i. The amount of agent required to extinguish the fire increases dramatically as the dimensionality of the fire increases. The result of this increased agent requirement is that critical application rates for one-dimensional fires may not be applicable for fires of higher dimension.

B. RECOMMENDATIONS

Based on the evaluation of the data generated as part of this effort and the above stated conclusions, the following recommendations are presented.

1. The developed apparatus, which represents a practical and accurate agent-evaluation method, should be incorporated into further agent-scoping studies to evaluate existing or newly developed agent technology. In addition the developed apparatus could be used as a training device for Air Force/Navy personnel.

2. A similar apparatus for a rod fire should be evaluated, to assess any practical differences between the two types of fires (cascading-fuel or rod) in regards to firefighting technique and/or agent requirements.

3. A search should be conducted for a three-dimensional agent with superior fuel inertion capabilities which would not suffer from the application, environmental, cleanliness, and toxicity problems of existing agents. This search should start with a fundamental study into the packaging and delivery of chemical agents, with the goal of developing a new first-line firefighting agent. The proposed effort is beyond the scope of this current study.

4. A fundamental study should be performed to quantify the observed multisource effect and to develop a reliable physical model which would

accurately describe a three-dimensional liquid fuel fire. This information is necessary for the evaluation of future agent requirements as well as the prediction of such things as cook-off times, skin burn-through times, and fuel tank-rupture times.

REFERENCES

1. S. J. Wiersma, et al., Characteristics of Kinematic Jet Fuel Fires, Cascading and Rod Fuel Geometries, Technical Report DOD-AGFSRS-76-3, Wright-Patterson Air Force Base, Ohio, October 1975.
2. S. J. Wiersma, et al., Design of a Cascade Fire Apparatus for Testing Countermeasure Effectiveness, Technical Report DOD-AGFSRS-76-7, Wright-Patterson Air Force Base, Ohio, June 1976.
3. G. Geyer, Equivalency Evaluation of Firefighting Agents and Minimum Requirements at U.S. Air Force Airfields, Technical Report DOT/FAA/CT-82/109, Federal Aviation Administration, Atlantic City Airport, N.J., October 1982.
4. R. L. Altman, et al., Development and Testing of Dry Chemicals in Advanced Extinguishing Systems for Jet Engine Nacelle Fires, Technical Report JTGG/AS-82-T-002, NASA-Ames Research Center, Mountain View, Ca., February 1983.
5. J. J. Bikerman, Foams: Theory and Industrial Applications, Reinhold Publishing Corp., New York, 1953, pp. 189-242.
6. Information Package on Fire Protection Systems and Components, MSA Research Corporation, Evans City, Pa.
7. R. C. Richards, High Expansion Foam Extinguishant of Machinery Space Fires, Technical Report CG-D-83-76, Department of Transportation United States Coast Guard Office of Research and Development, Washington, D.C., December 1975.
8. Fire Extinguishing Agent, Aqueous Film-Forming Foam, (AFFF) Liquid Concentrate, for Fresh and Sea Water, MIL-F-24385C, 1983.

9. C. S. McCamy, et al. Sixteenth Symposium (International) on Combustion, Combustion Institute, 1976, p 795.
10. T. Mitani, and T. Niioka, Nineteenth Symposium (International) on Combustion, Combustion Institute, 1982, p 869.
11. C. T. Ewing, et al., Fire and Materials, Vol. 8, No. 3, 1984, p 148.
12. H. Y. Safeih, et al., Nineteenth Symposium (International) on Combustion, Combustion Institute, 1982, p 117.
13. R. G. Gann, "Halogenated Fire Suppressants," ACS Symposium Series, Vol. 16, American Chemical Society, Washington D. C., 1975.
14. R. Hill, Evaluation of a Halon 1301 System for Aircraft Internal Protection from a Postcrash External Fuel Fire, Technical Report FAA-RD-76-218, Federal Aviation Administration, Systems Research and Development Service, Washington, D.C., March 1977.
15. G. R. Rose, U.S. Patent 4,390,069.
16. S. Atallah, et al., Development of Halogenated Hydrocarbon Foam (Halofoam) Extinguishants, Technical Report AFAPL-TR-71-21, Wright-Patterson Air Force Base, Ohio, April 1971.
17. P. N. Boris, et al., Advanced Fire Extinguishers For Aircraft Habitable Compartments, Technical Report AFAPL-TR-79-2036, Wright-Patterson Air Force Base, Ohio, October 1979.
18. Halofoam A New Fire Fighting Idea, Phamplet Produced by RTG Inc., West Germany.
19. S. H. Kung, U. S. Patent 4,226,728.

20. D. E. Breen, Combination of Halons 1301 and 1211 as Fire Suppressants, Factory Mutual Research Corporation Report, FMRC Serial No. 22440 RC75-T-24, 1975.

- 21) J. Mansfield, The Characterization of Flight Deck Fires, Naval Research Laboratory, unpublished report.

Appendix A

As part of this effort time and temperature data were collected as described previously. Contained in this appendix are copies of the computer generated time-temperature graphs. The graphs contain information from all of the thermocouple positions defined in the legend and described previously. For information regarding other conditions of each test please refer to information contained in Tables 14-16 of the main body.

COMPOSITE, TEST045

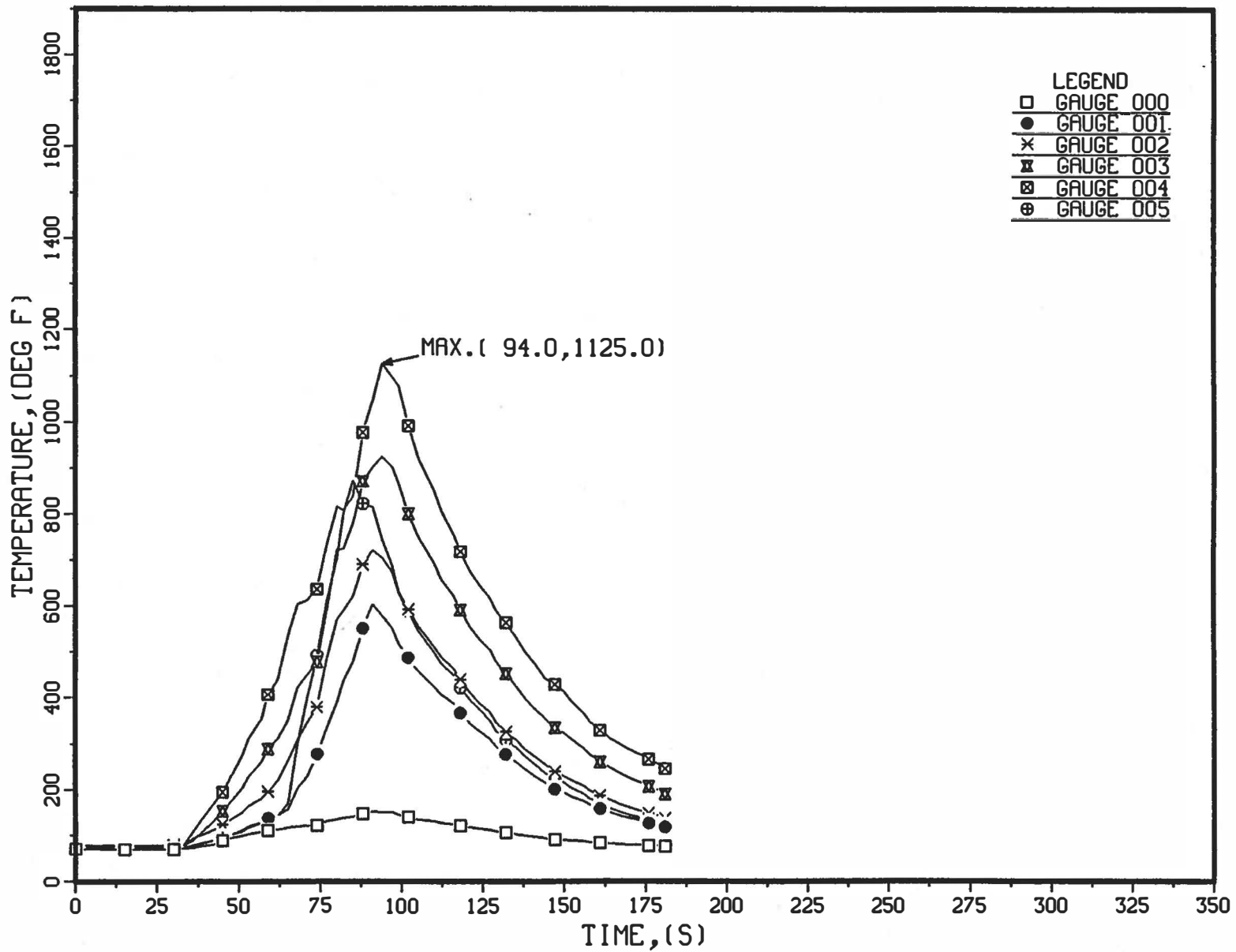

COMPOSITE, TEST046

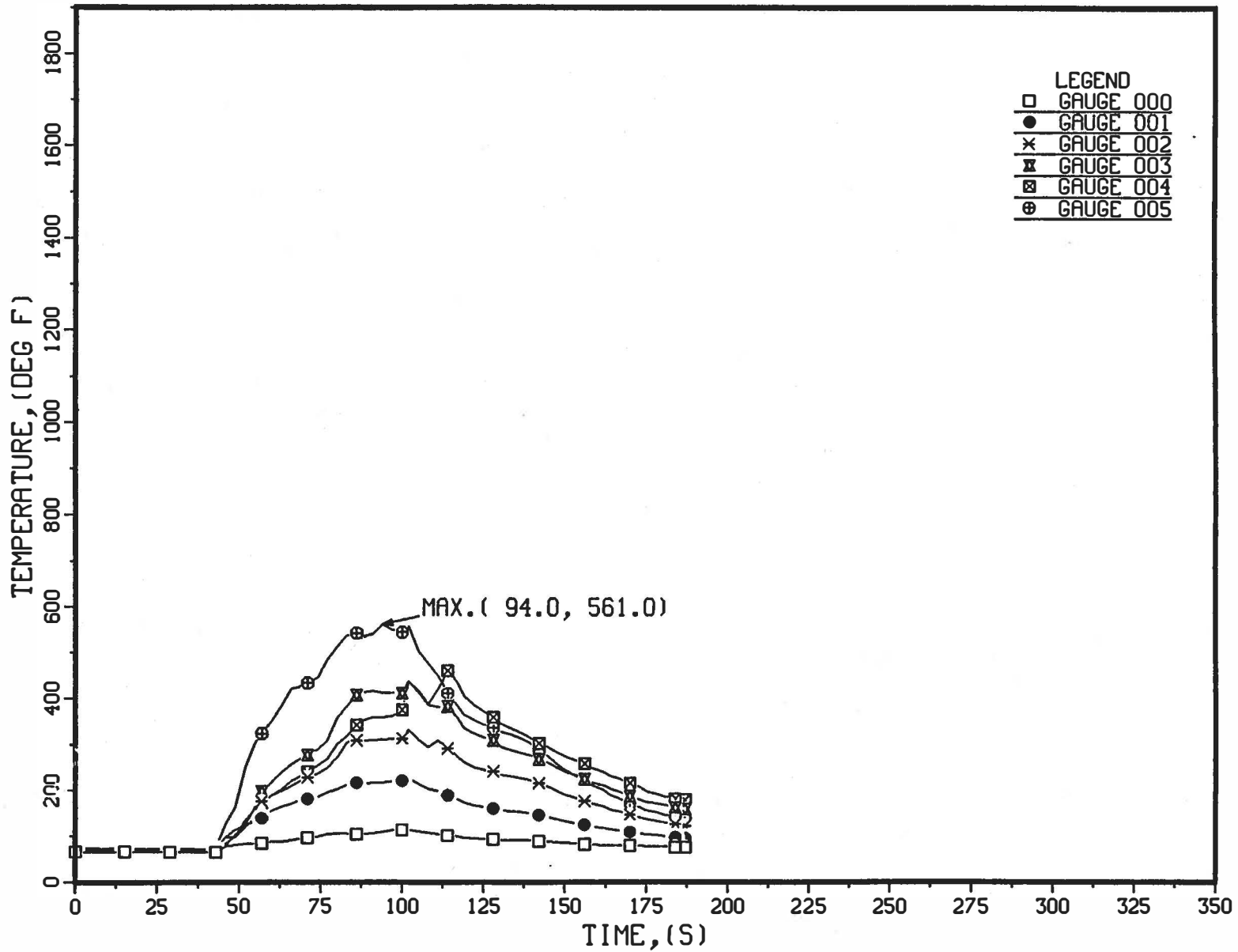

COMPOSITE, TEST051

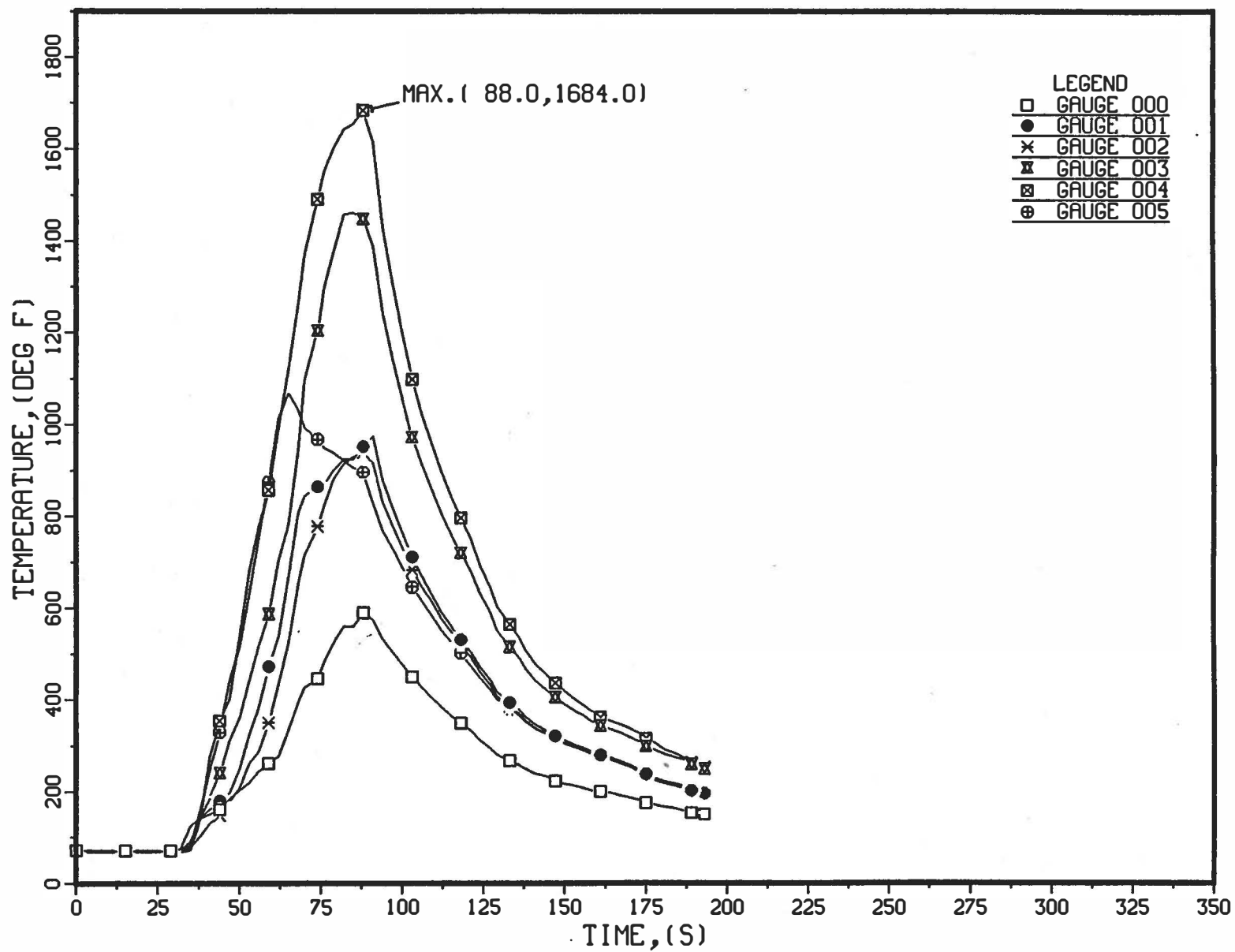

COMPOSITE, TEST053

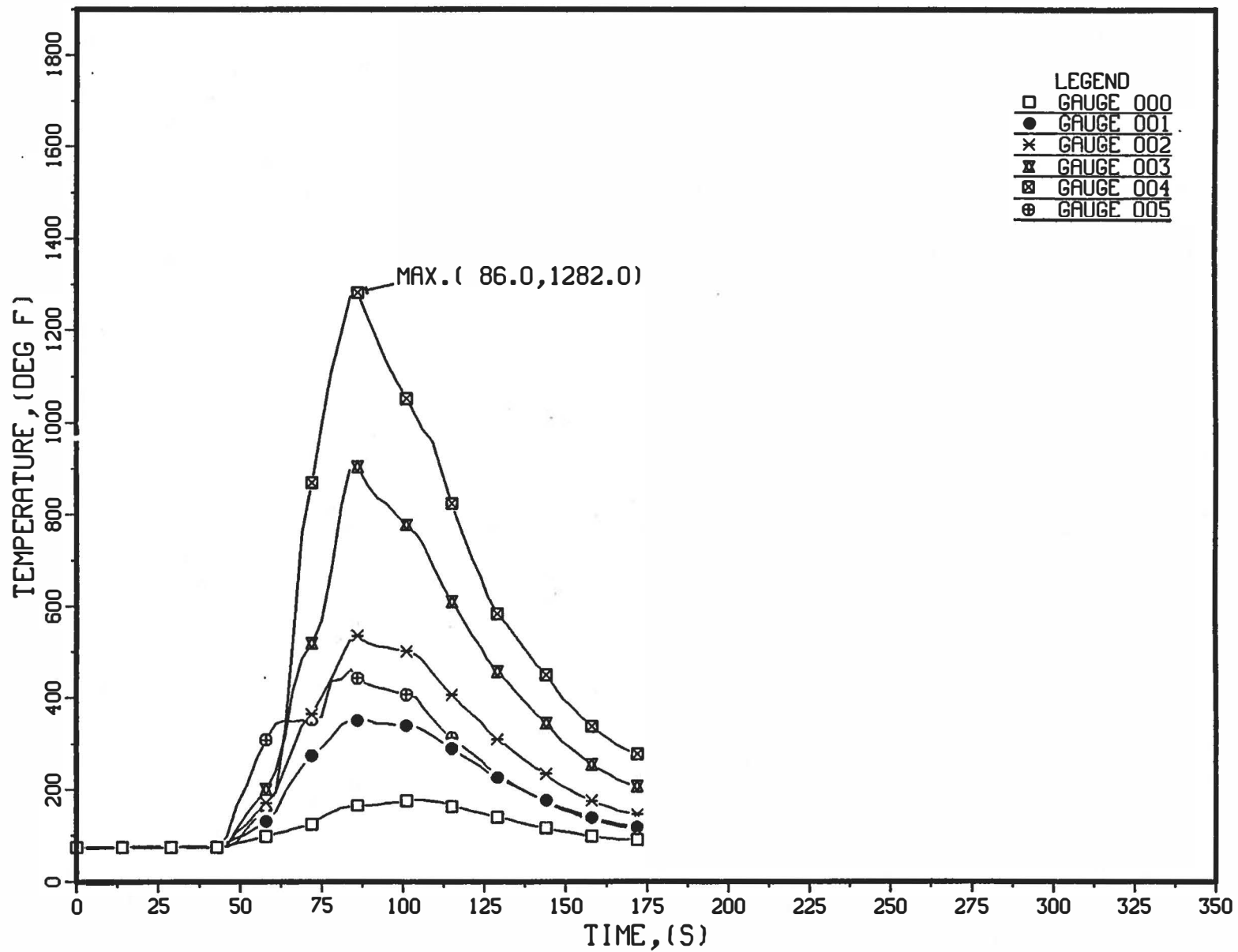

COMPOSITE, TEST063

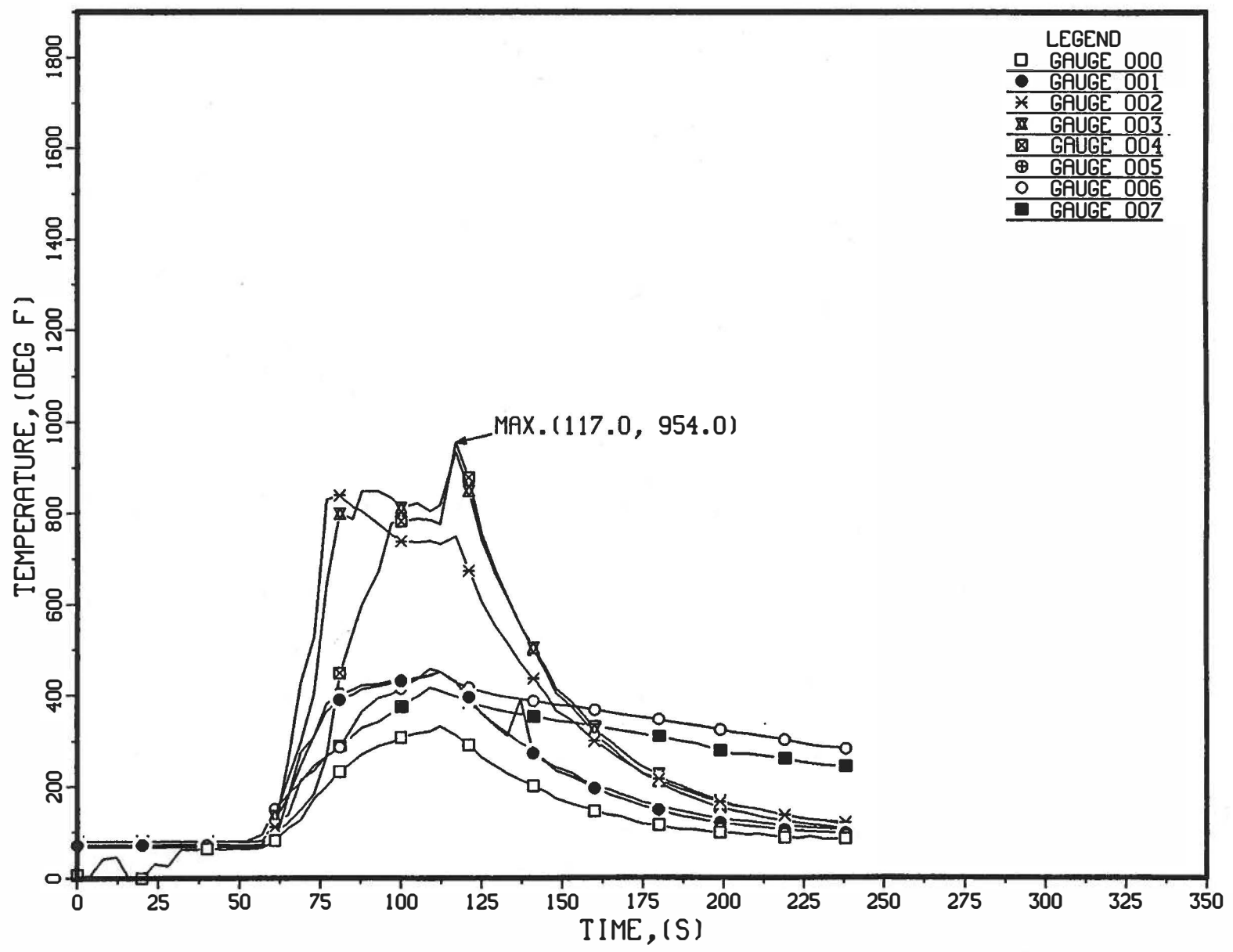

COMPOSITE, TEST064

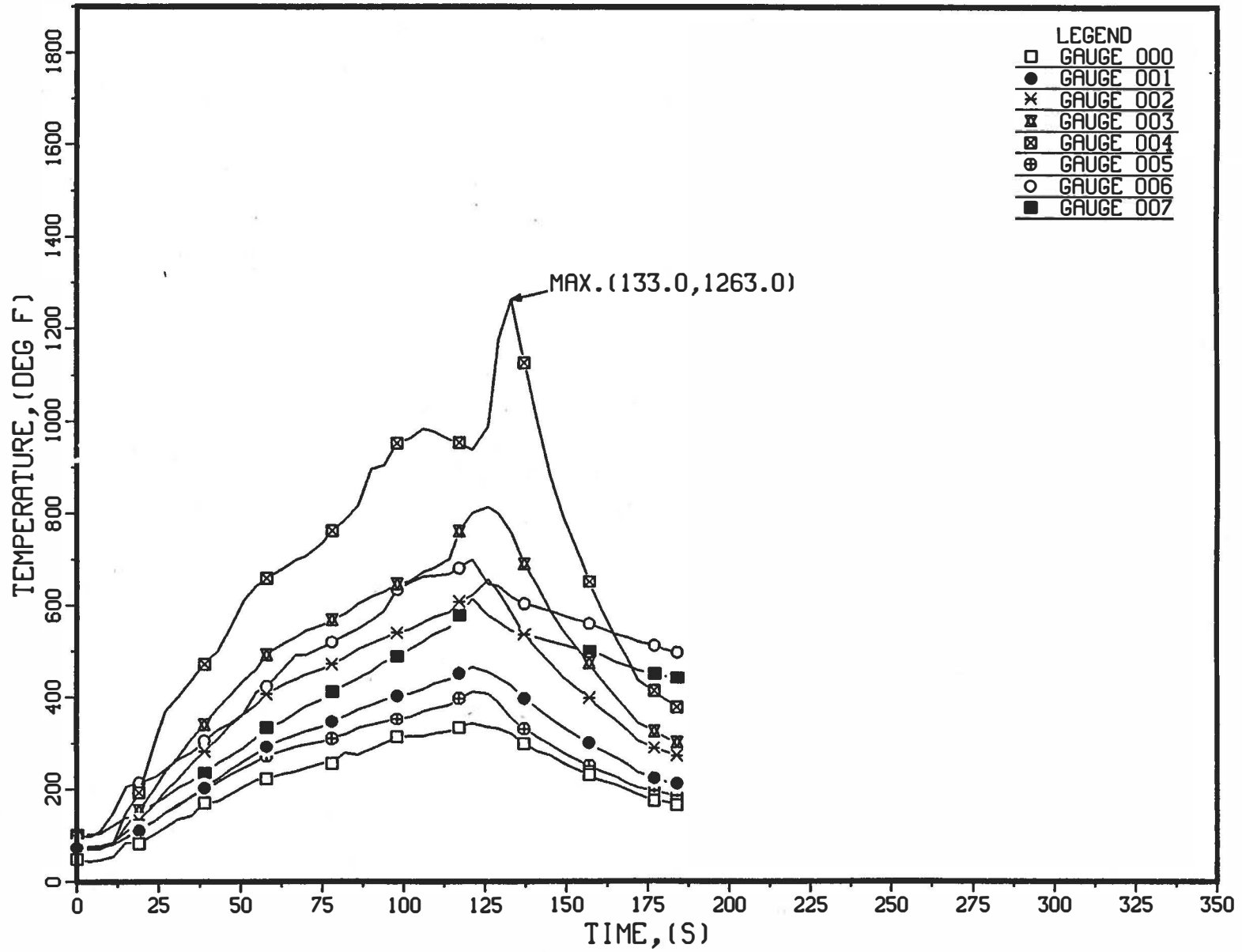

COMPOSITE, TEST065

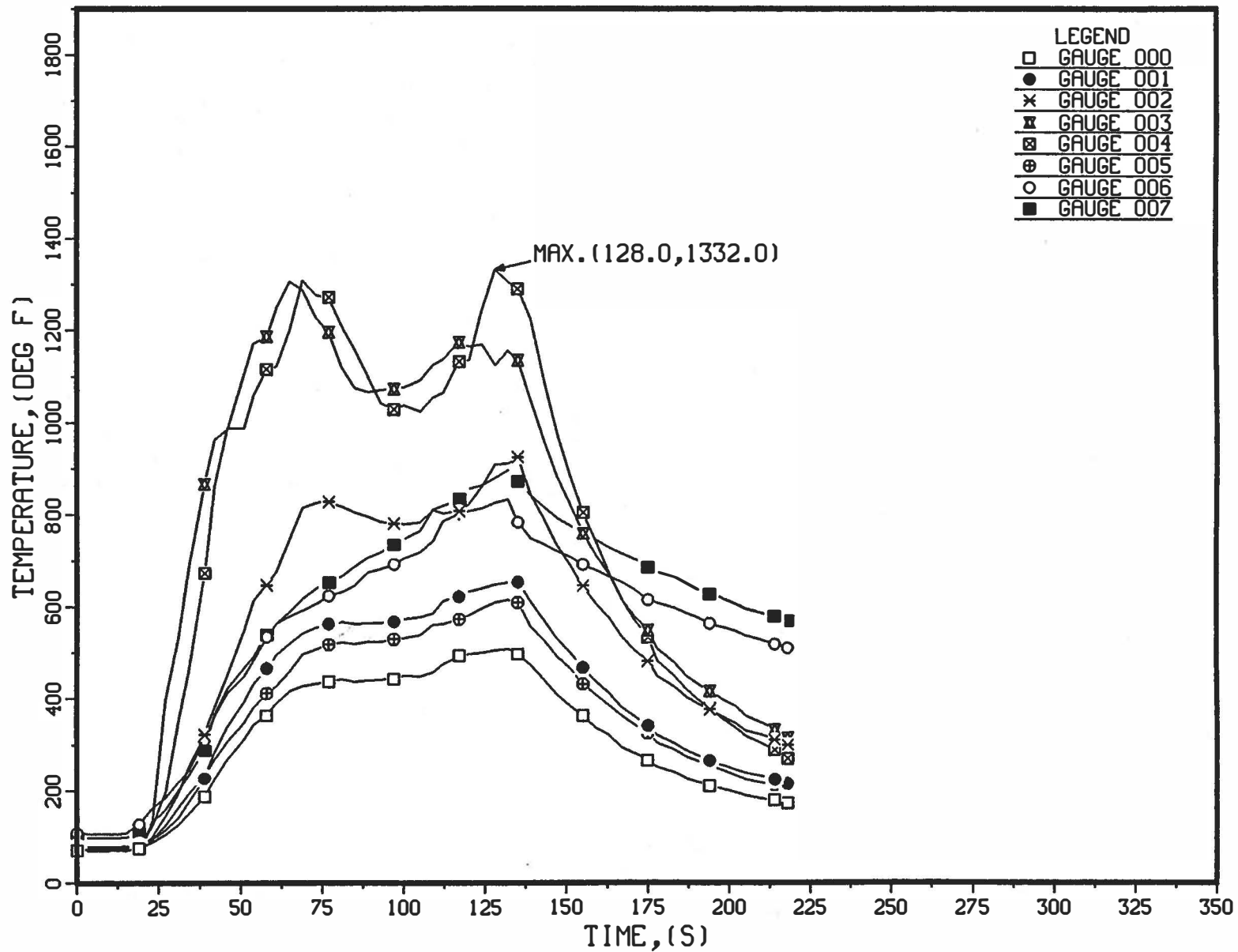

COMPOSITE, TEST066

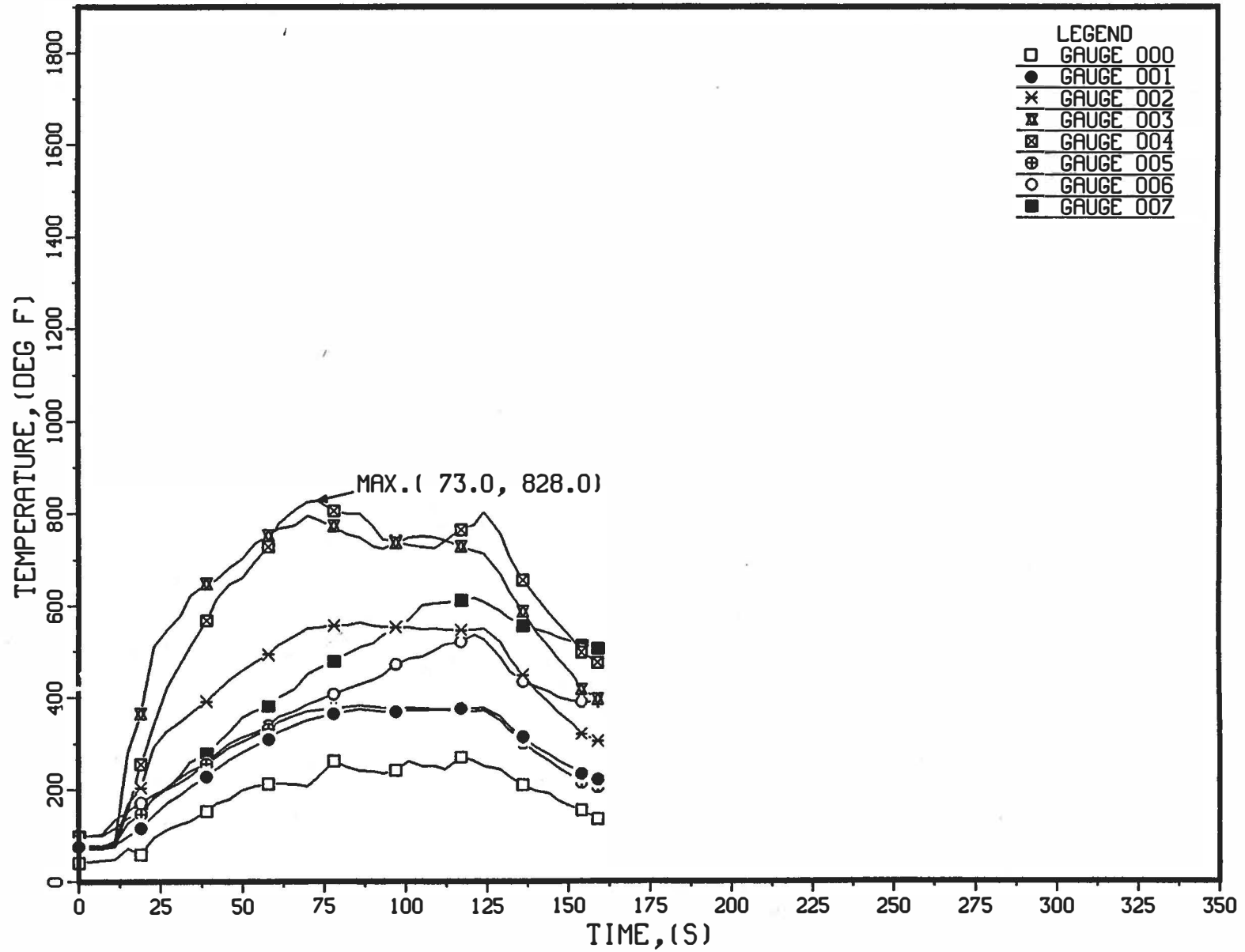

COMPOSITE, TEST071

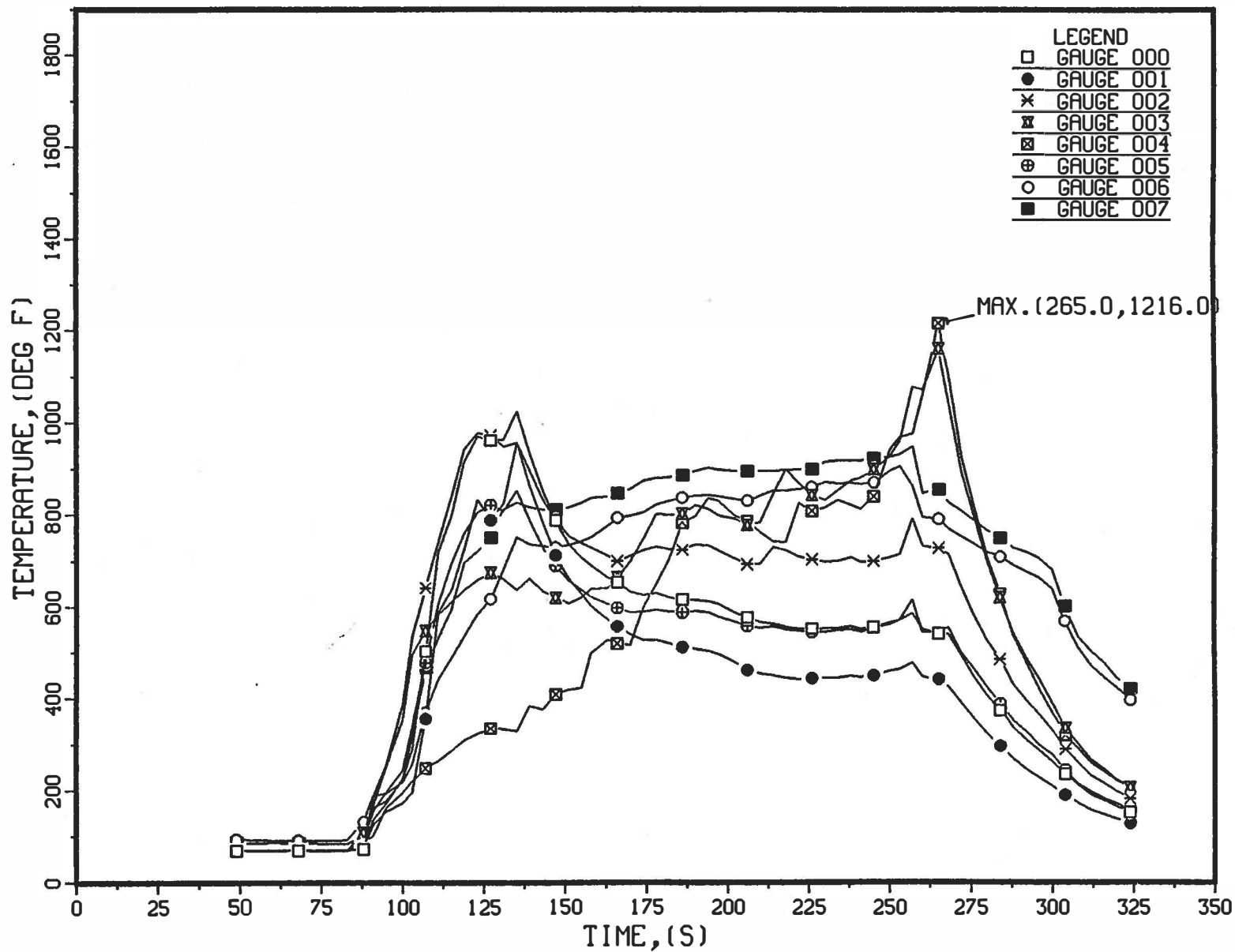

COMPOSITE, TEST072

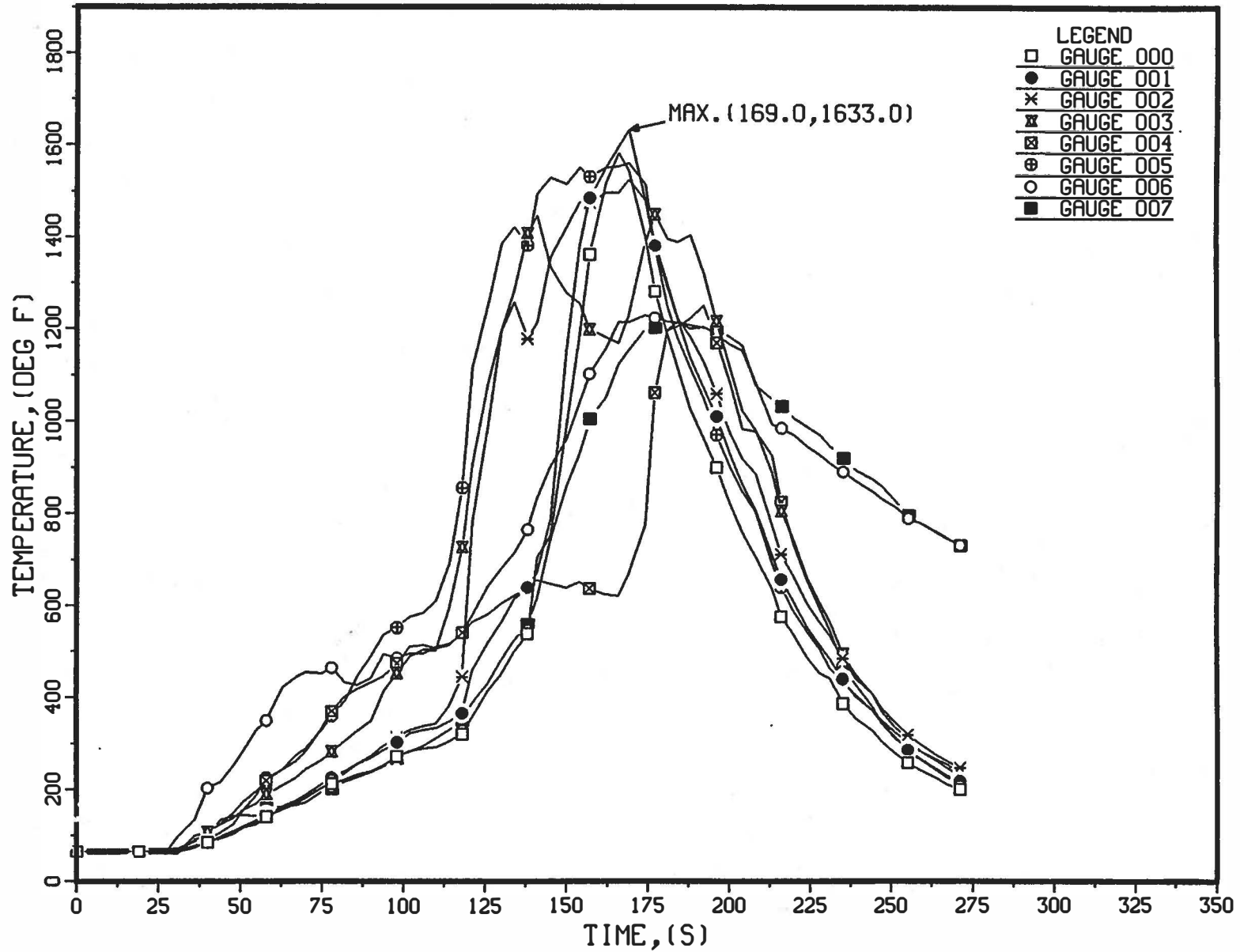

COMPOSITE, TEST075

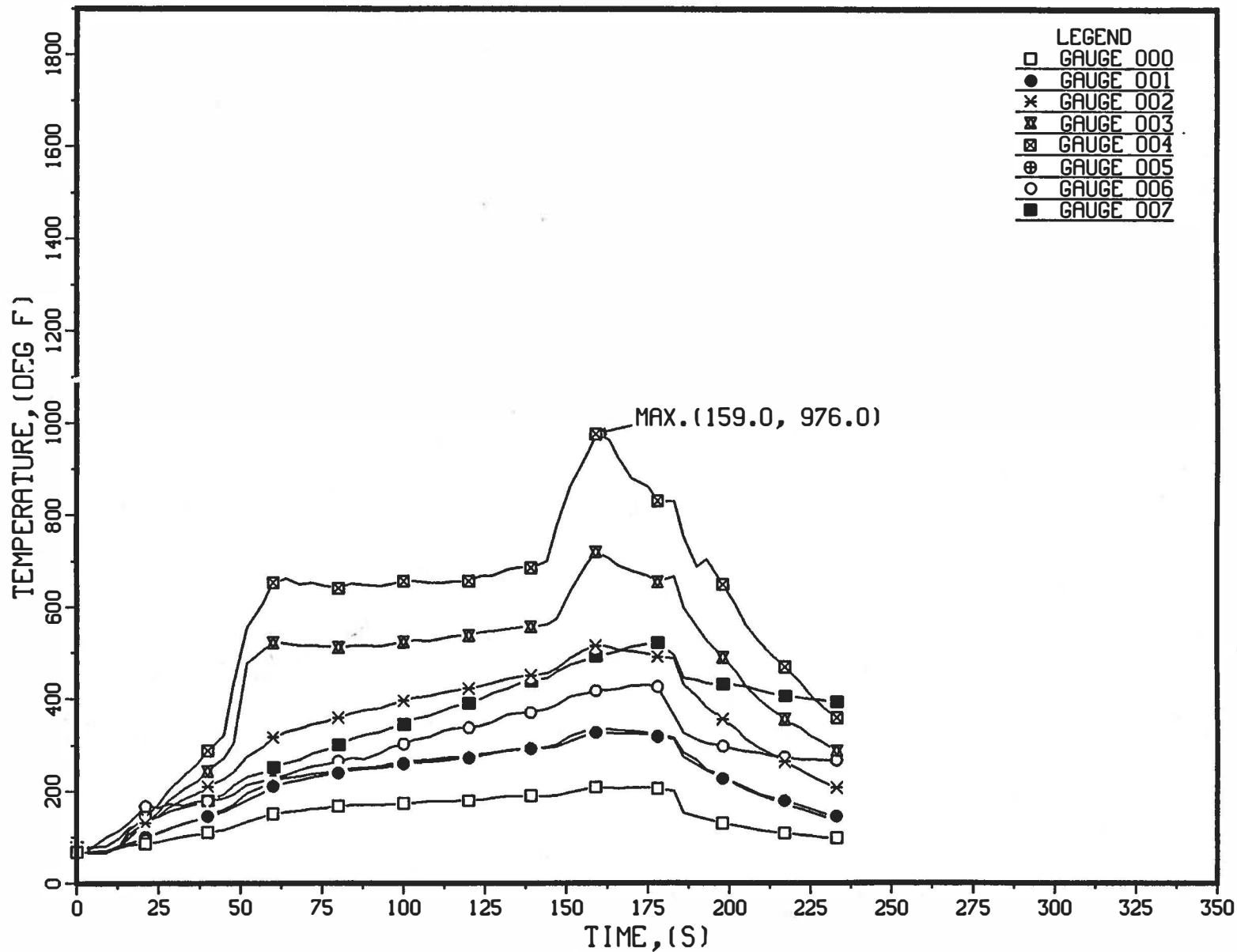

COMPOSITE, TEST076

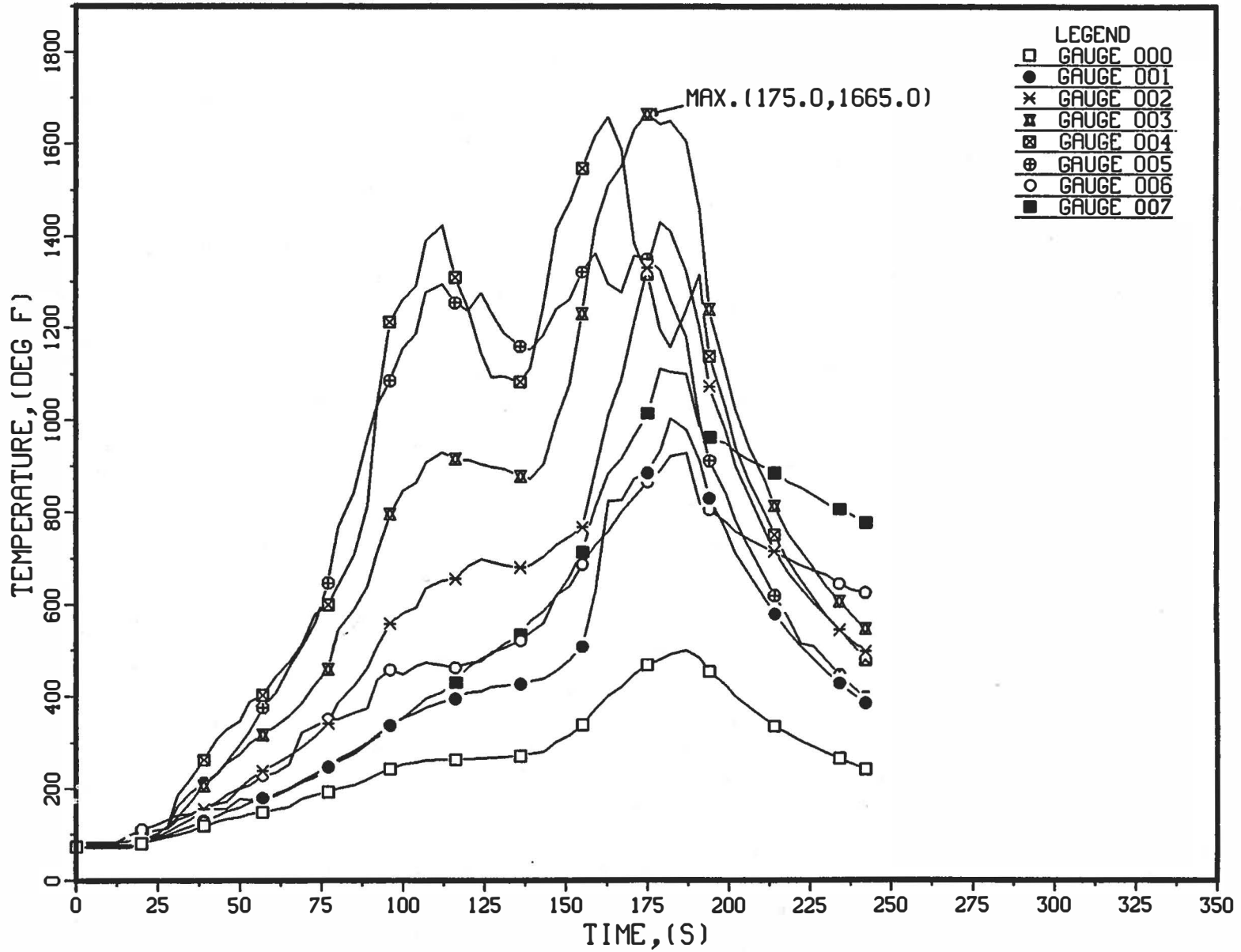

COMPOSITE, TEST077

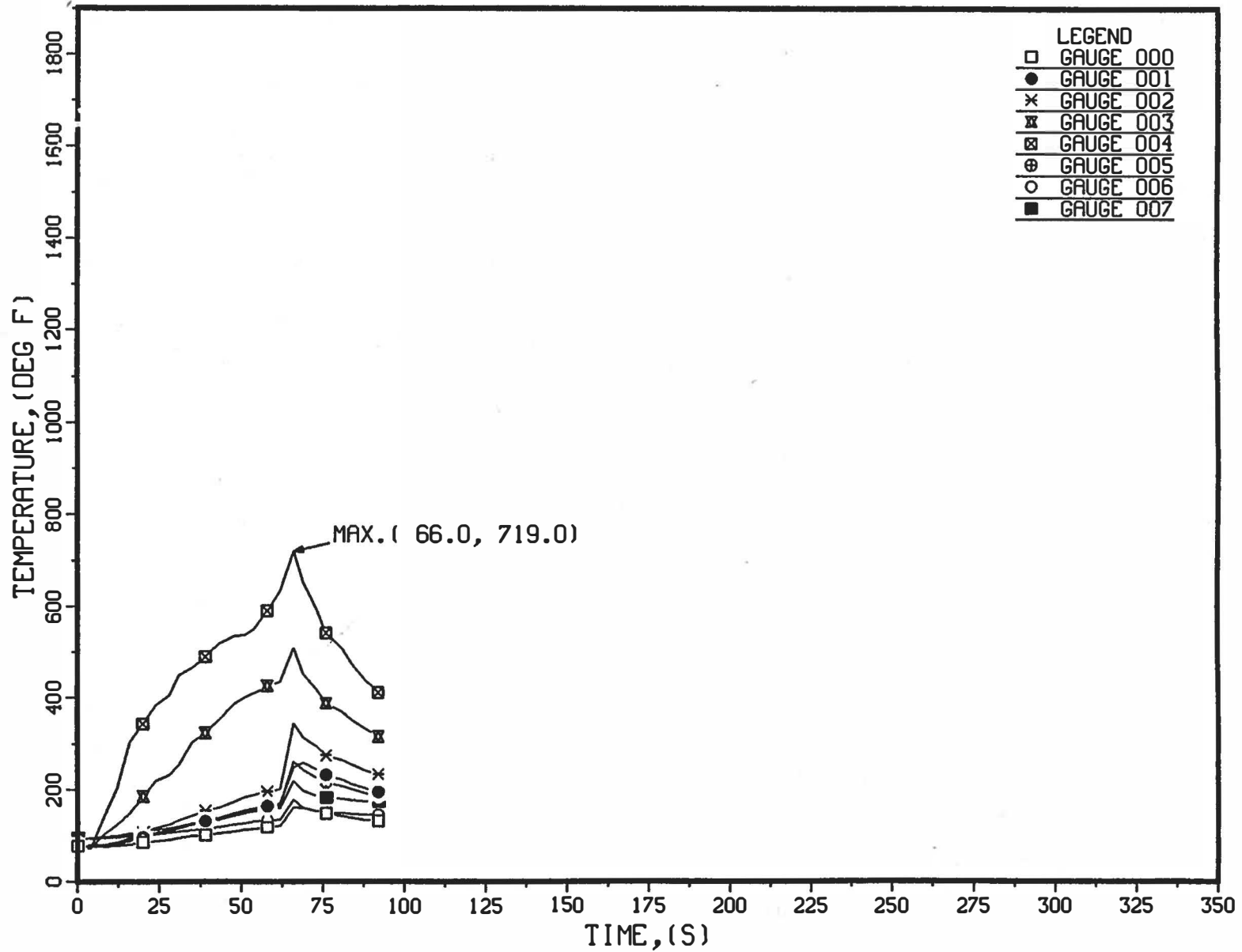

COMPOSITE, TEST078

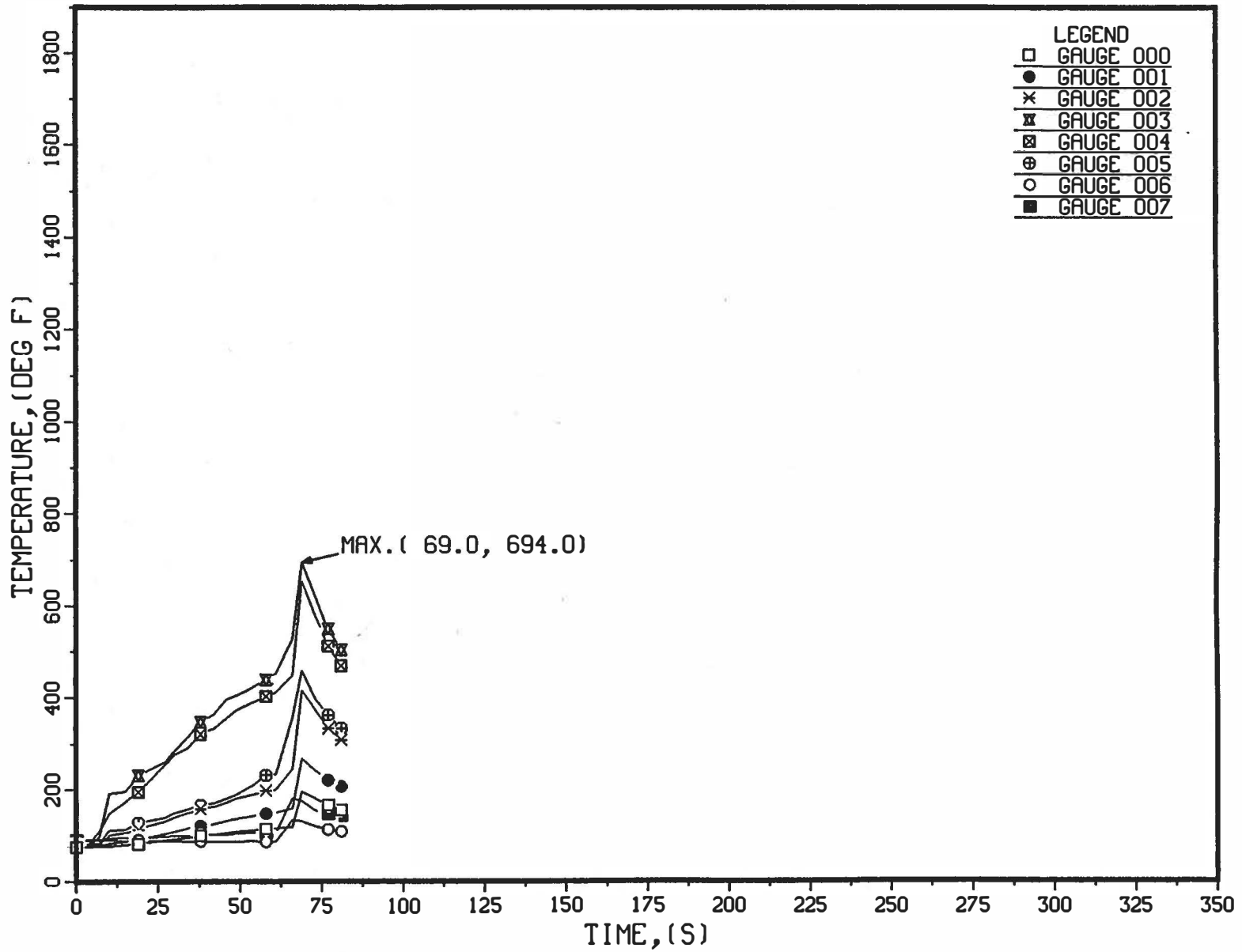

COMPOSITE, TEST079

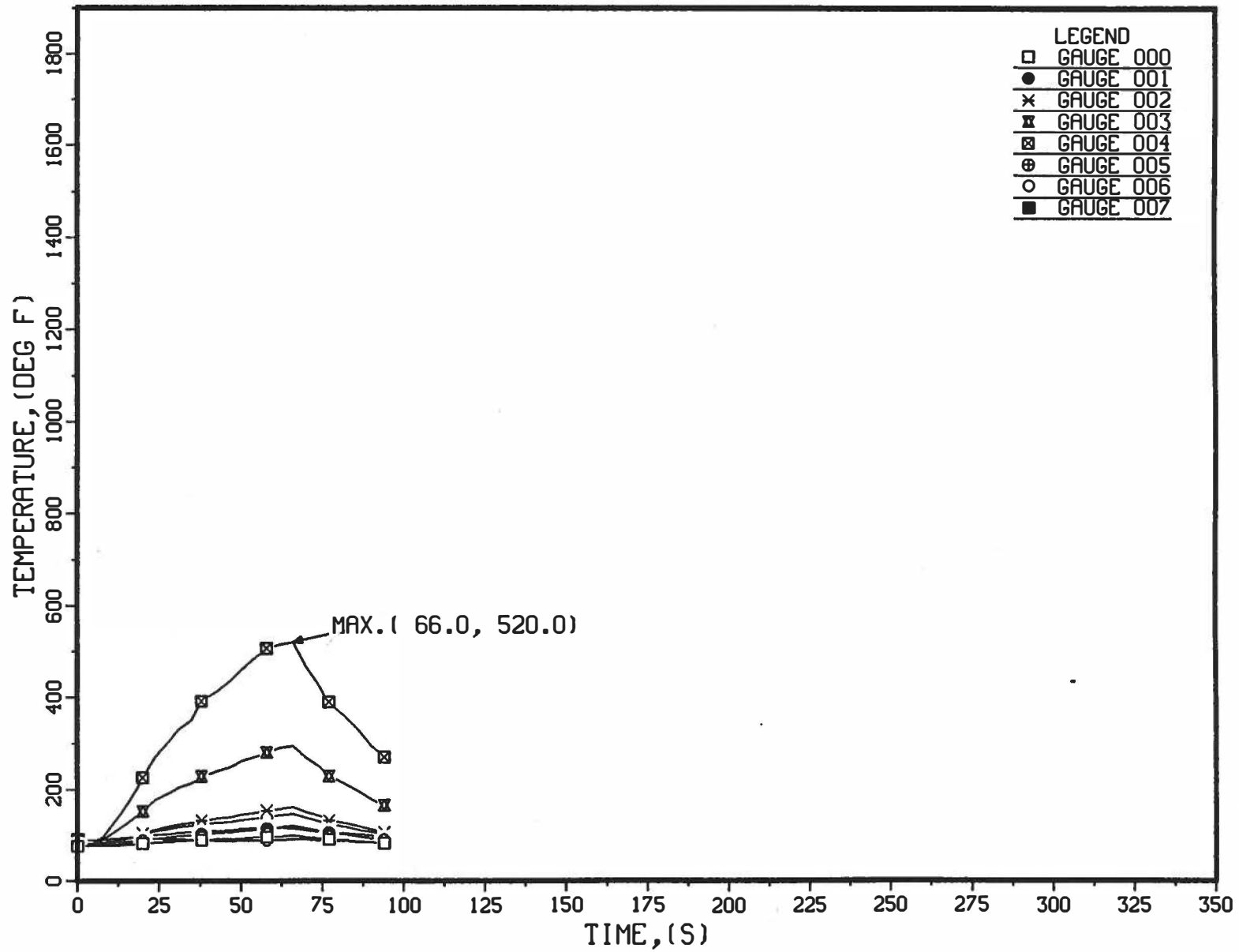

COMPOSITE, TEST080

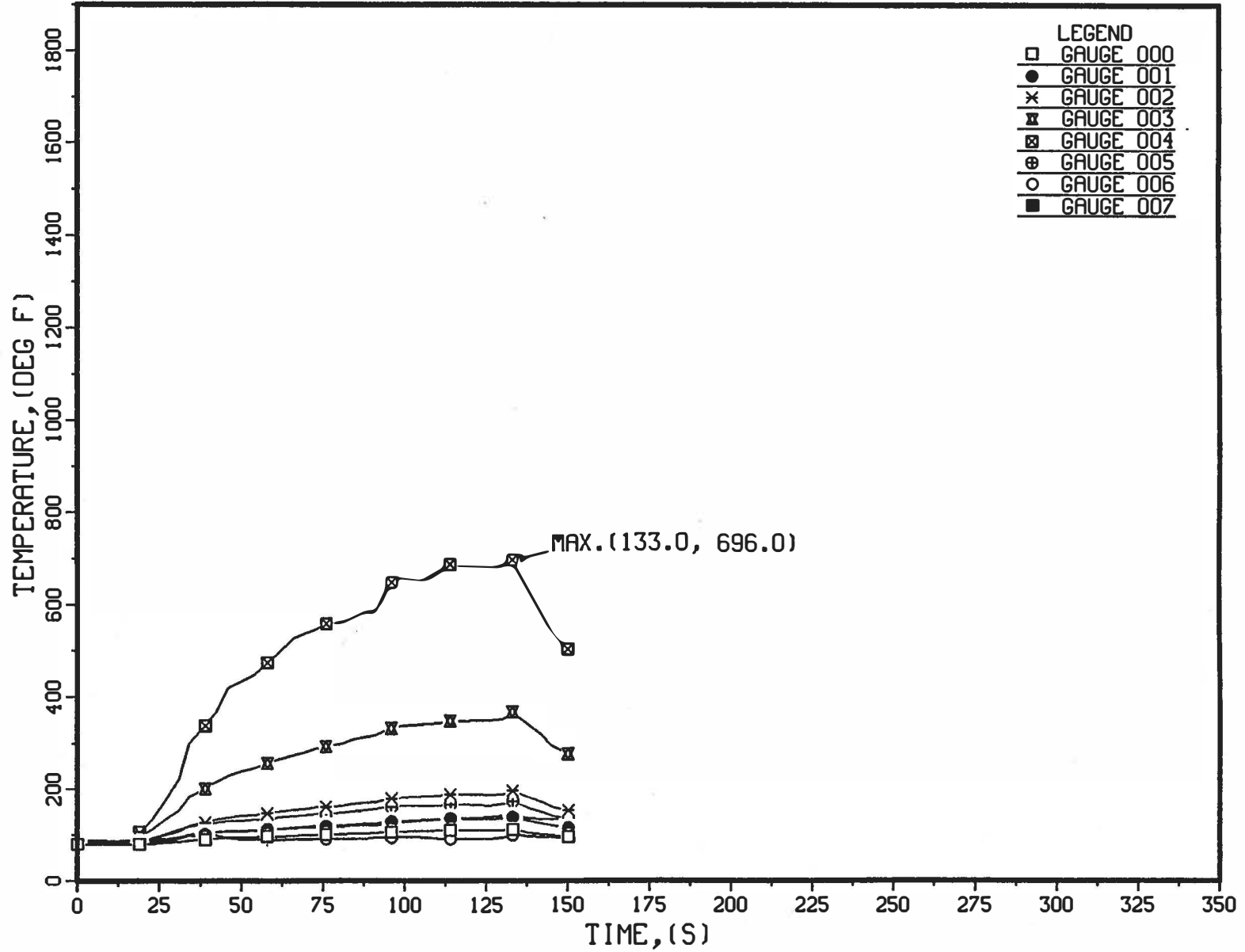

COMPOSITE, TEST081

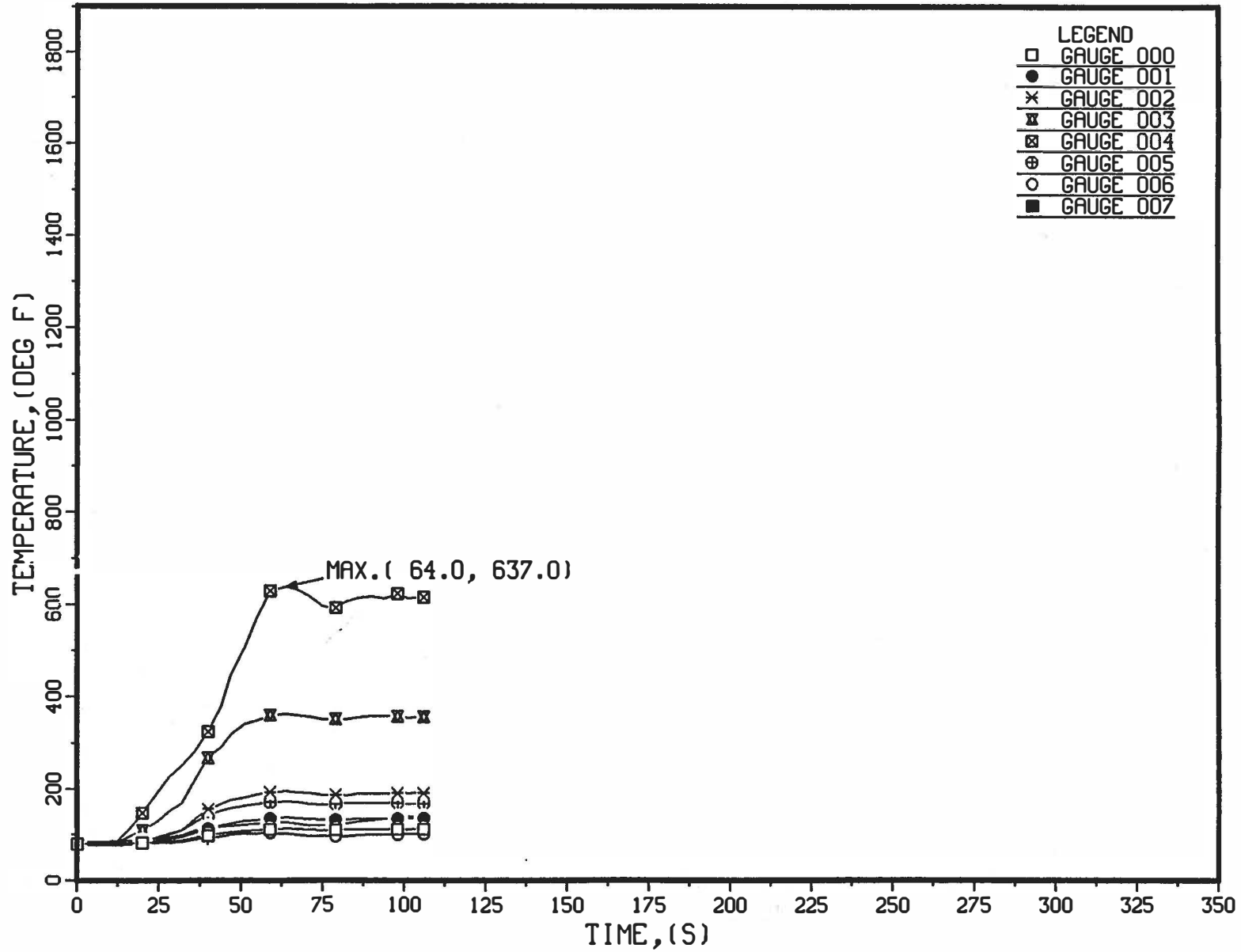

COMPOSITE, TEST083

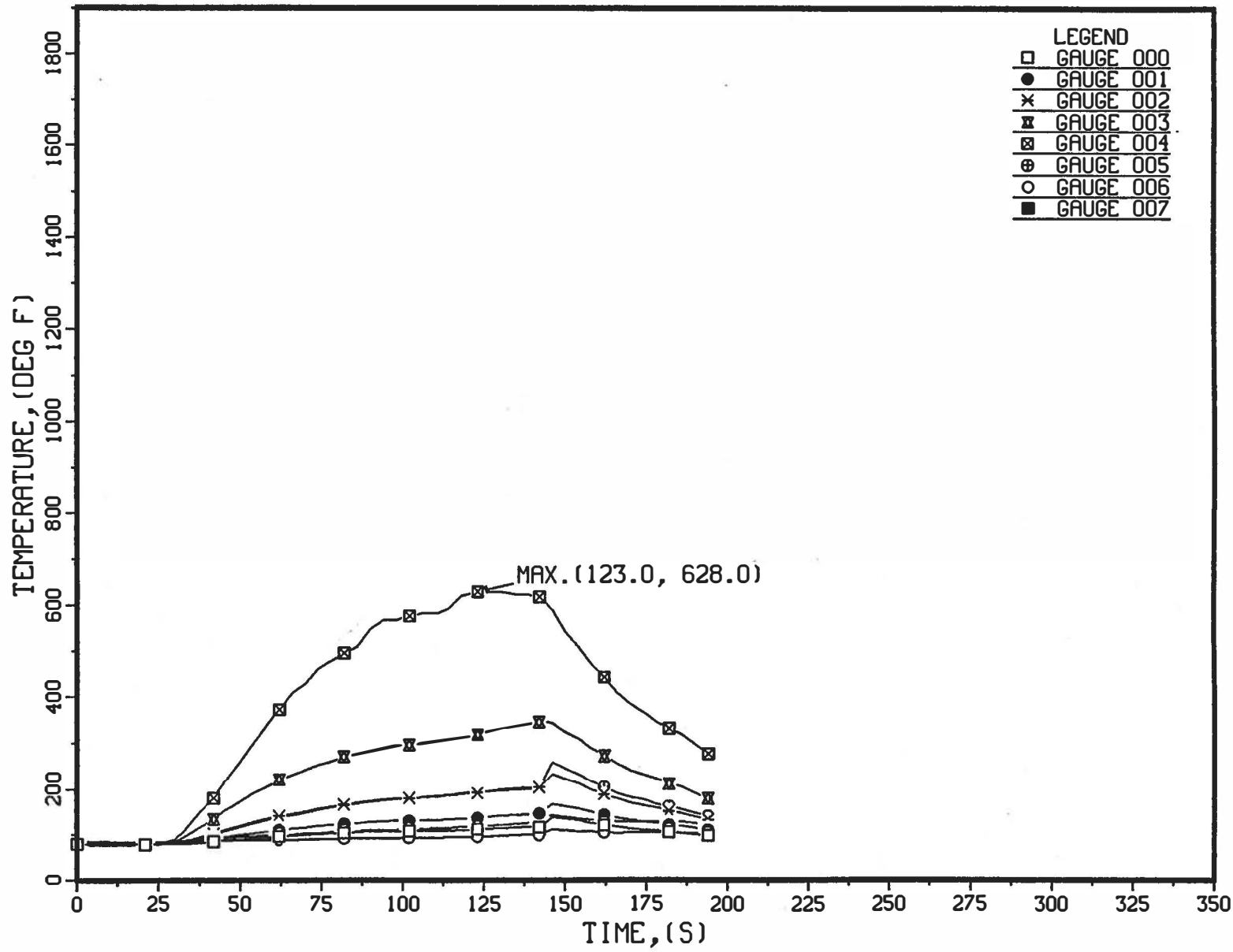

COMPOSITE, TEST084

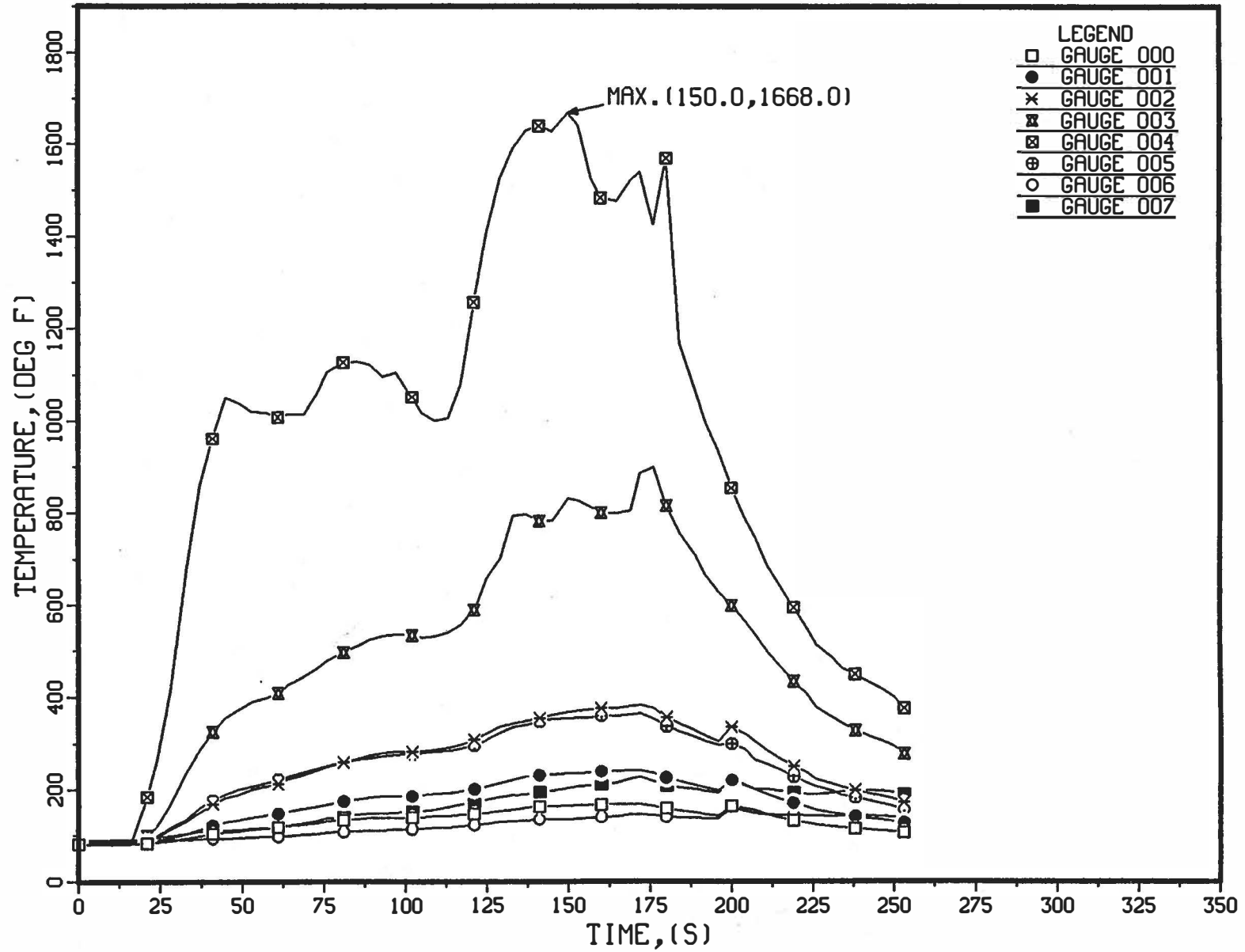

COMPOSITE, TEST085

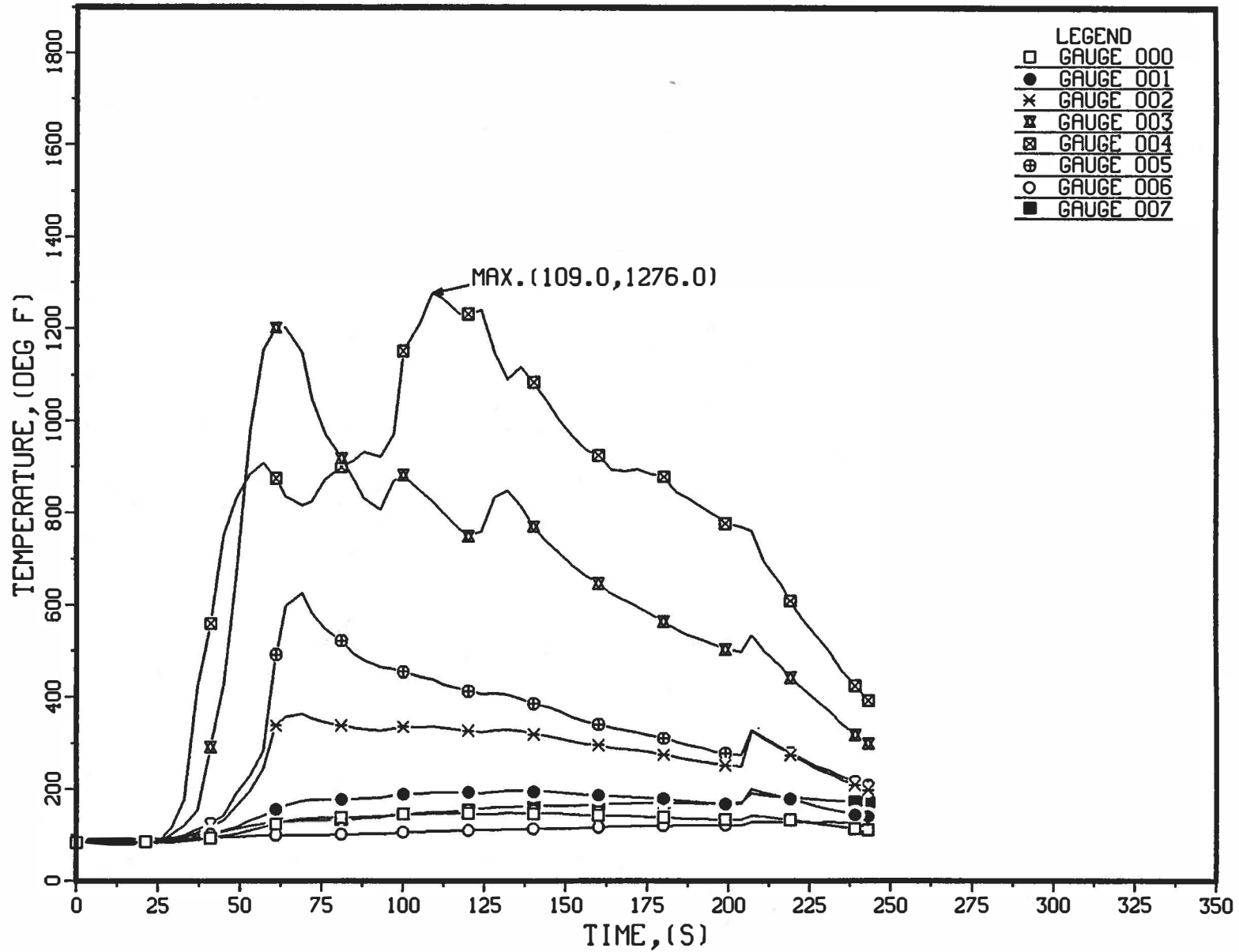

COMPOSITE, TEST095

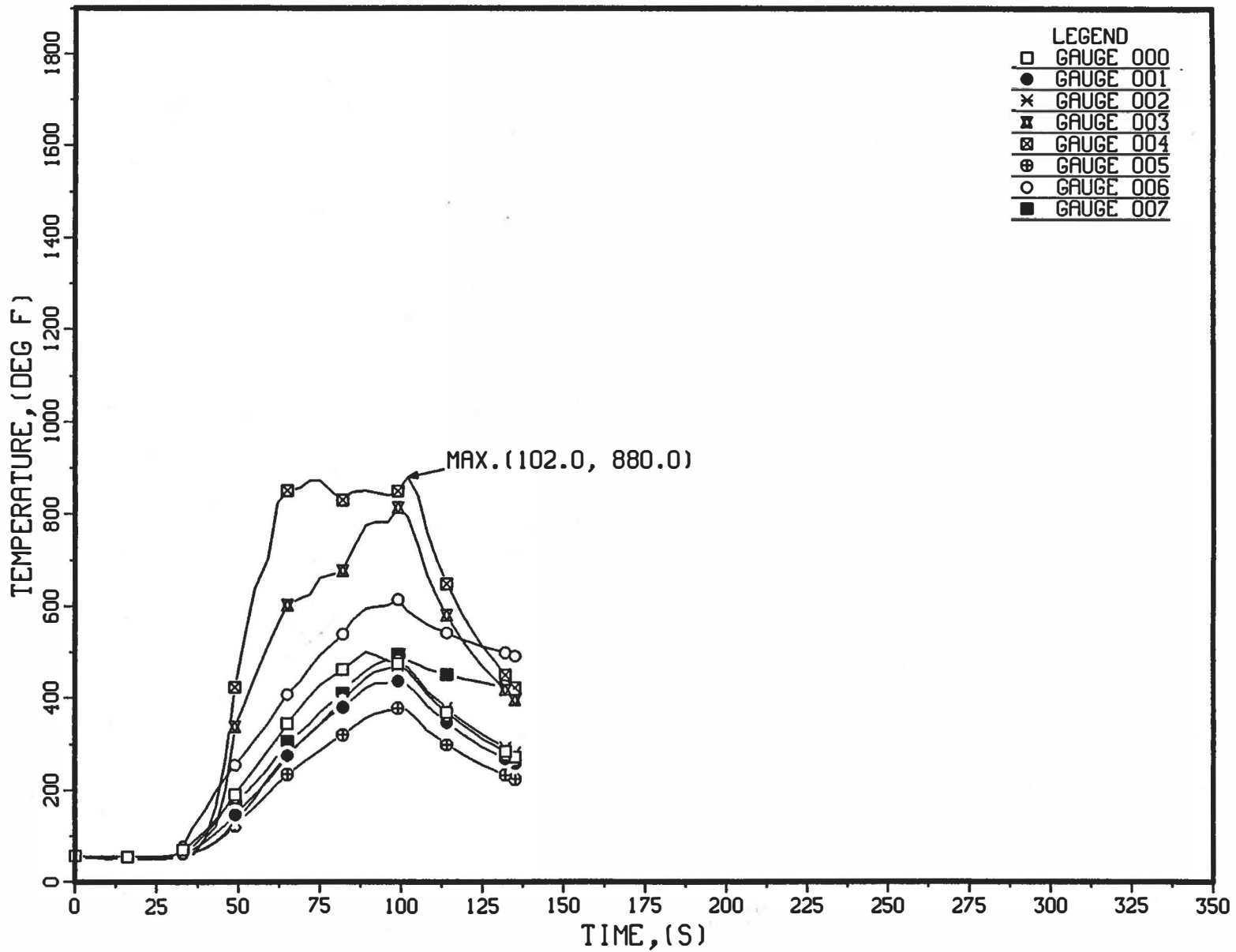

COMPOSITE, TEST096

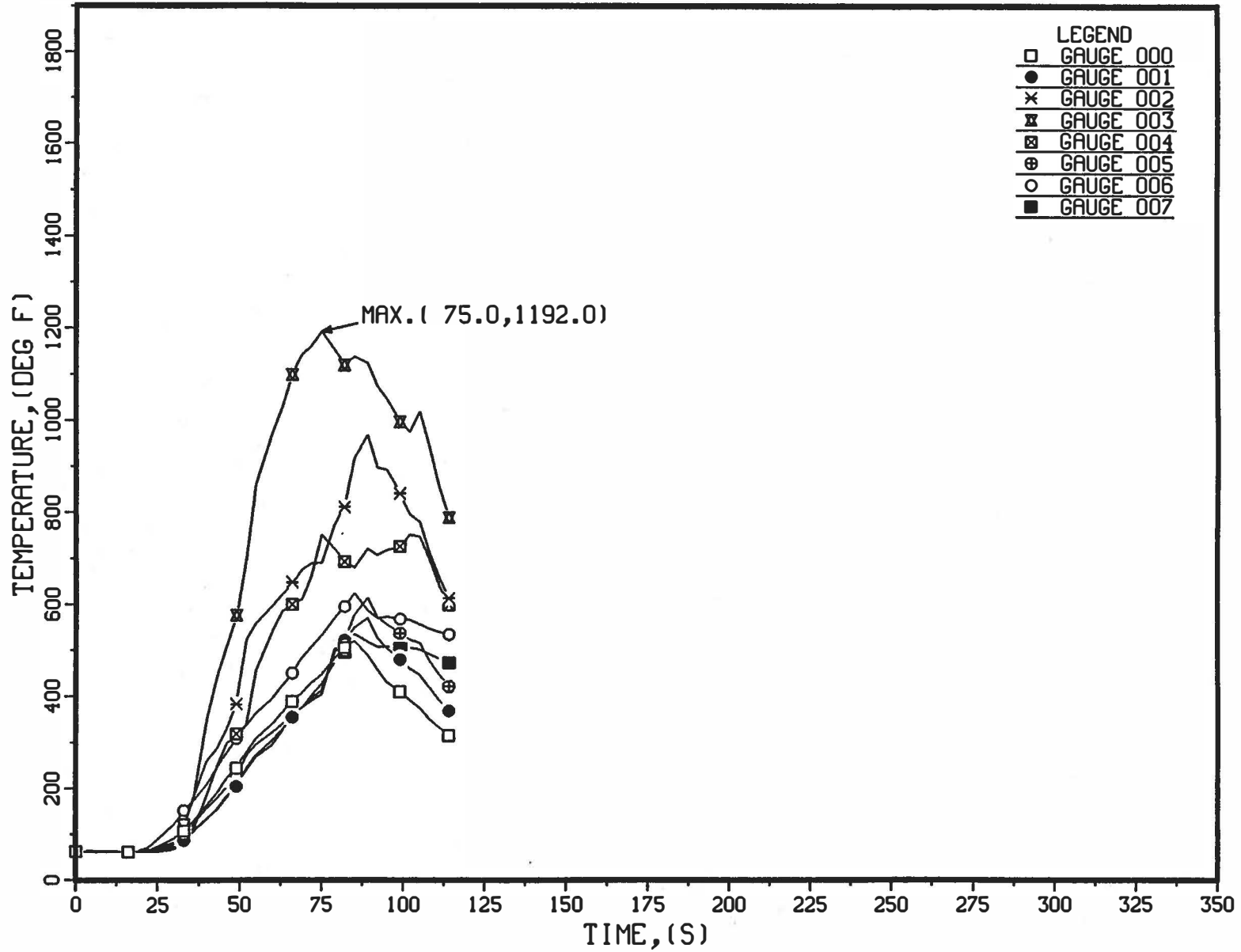

COMPOSITE, TEST097

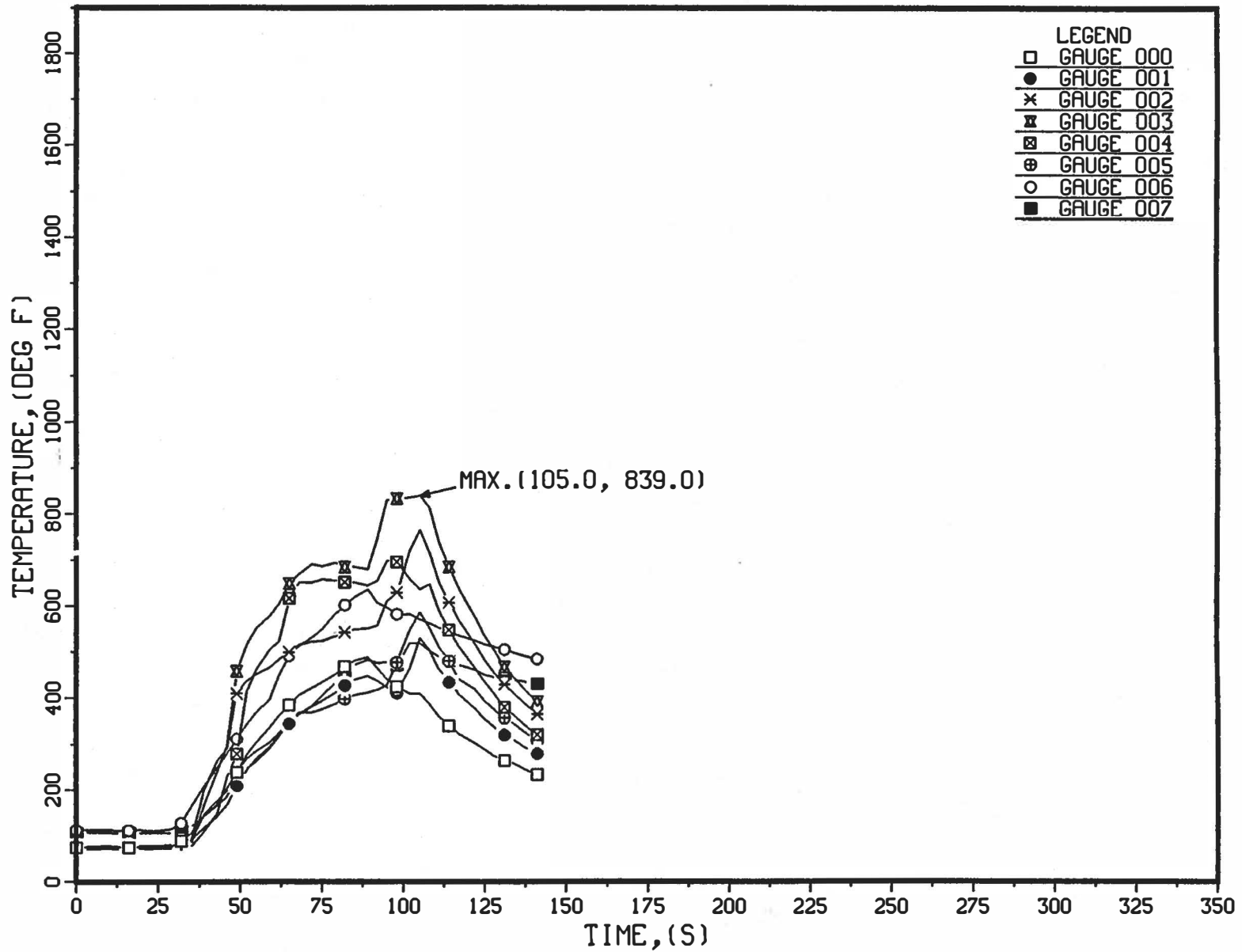

COMPOSITE, TEST098

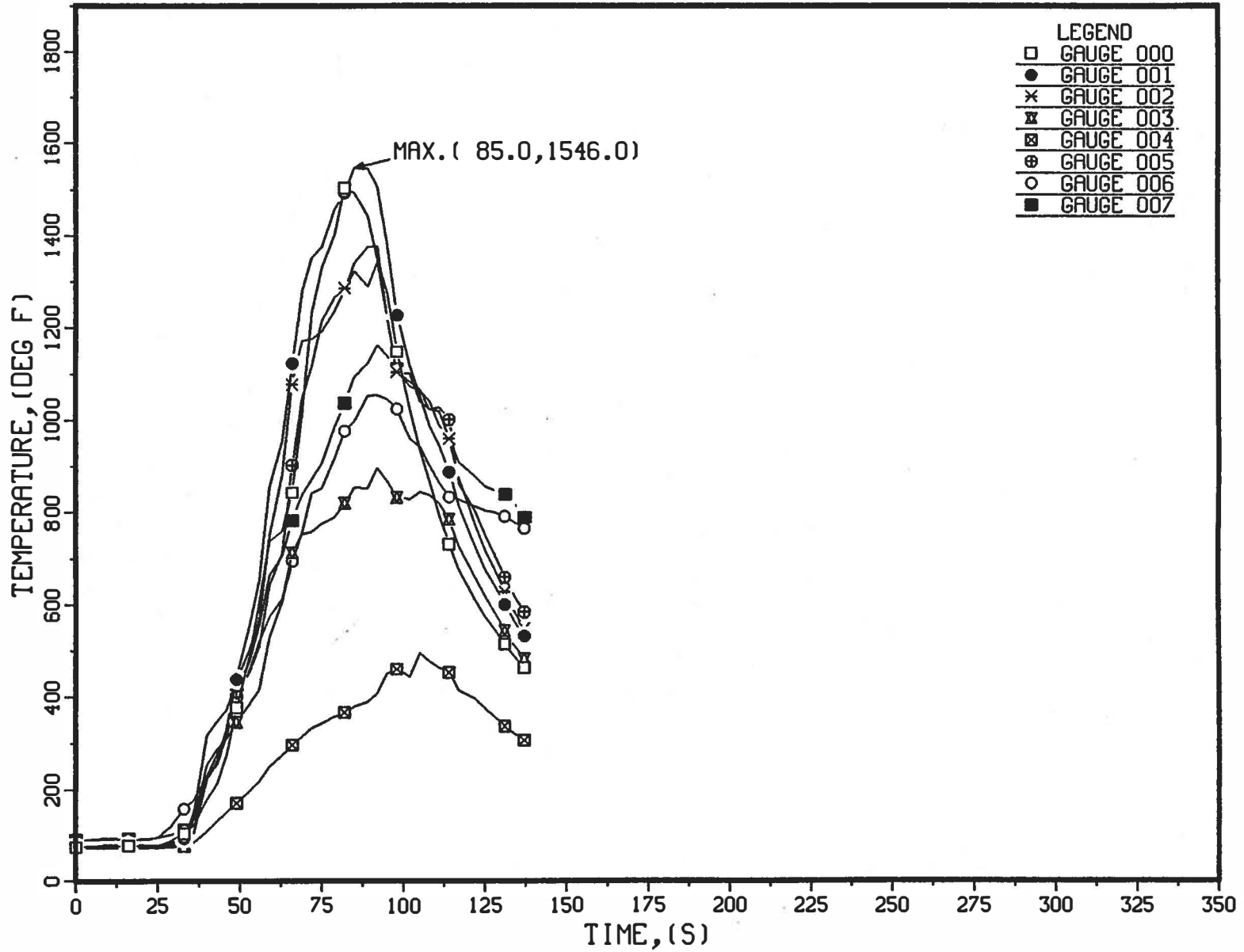

COMPOSITE, TEST109

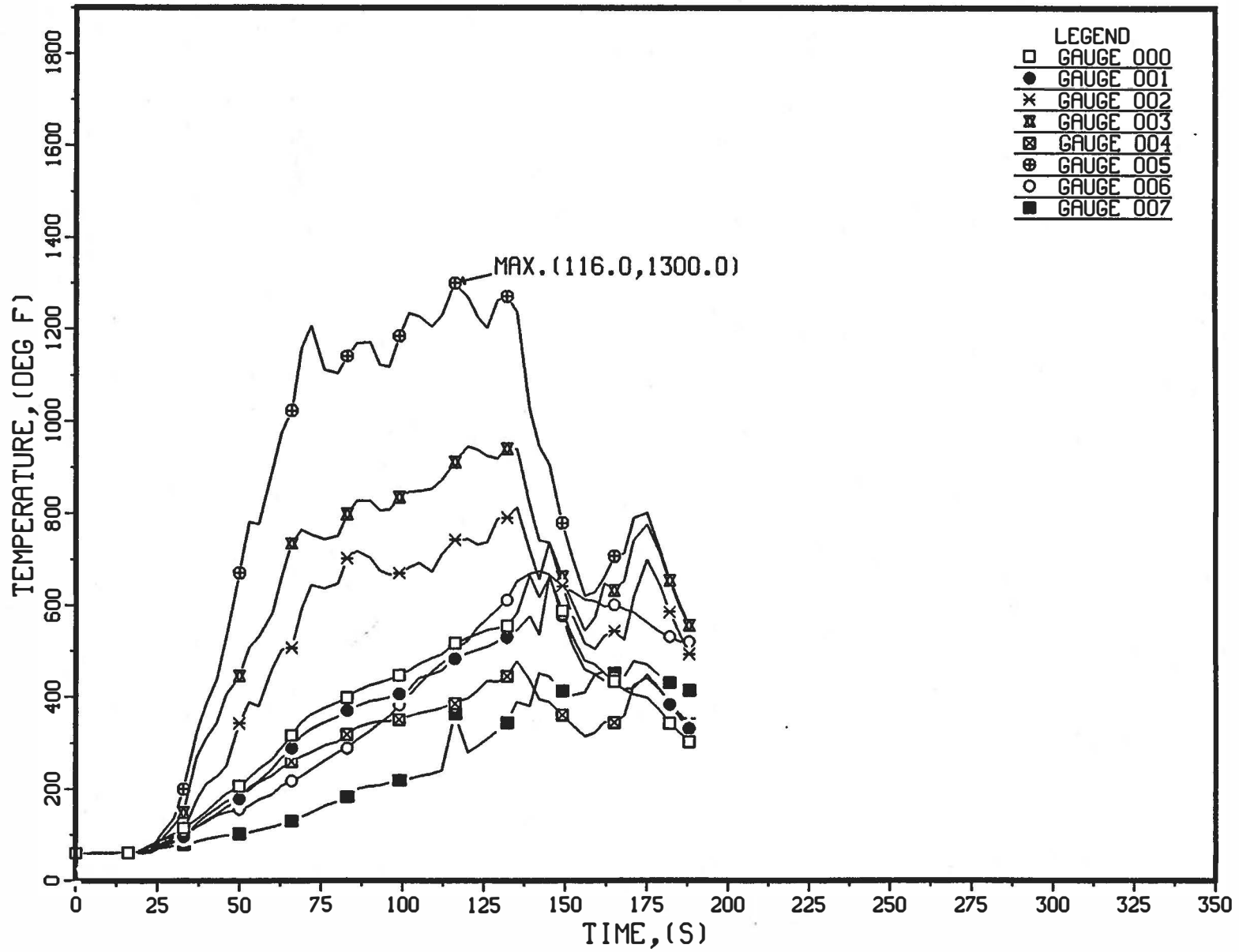

COMPOSITE, TEST110

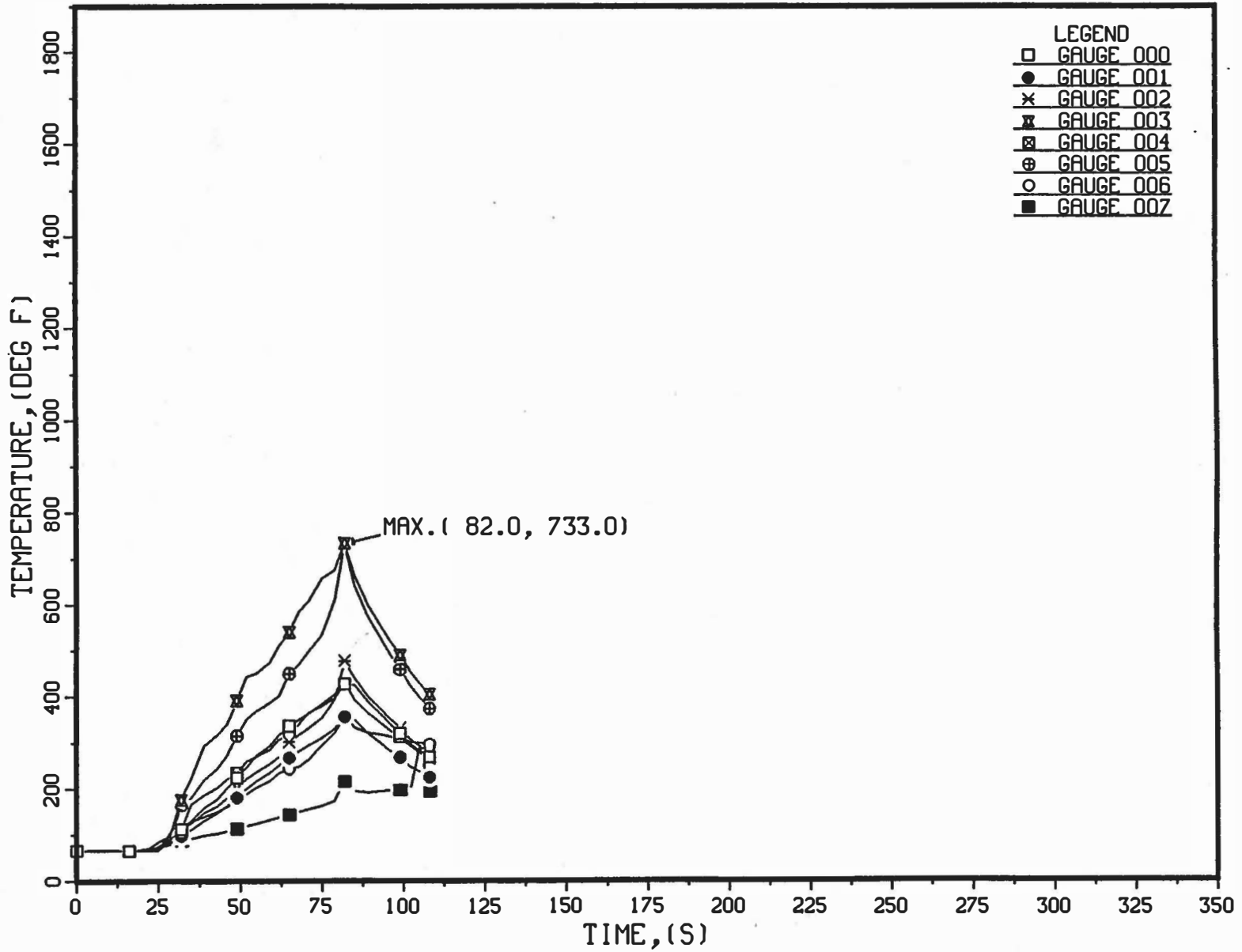

COMPOSITE, TEST115

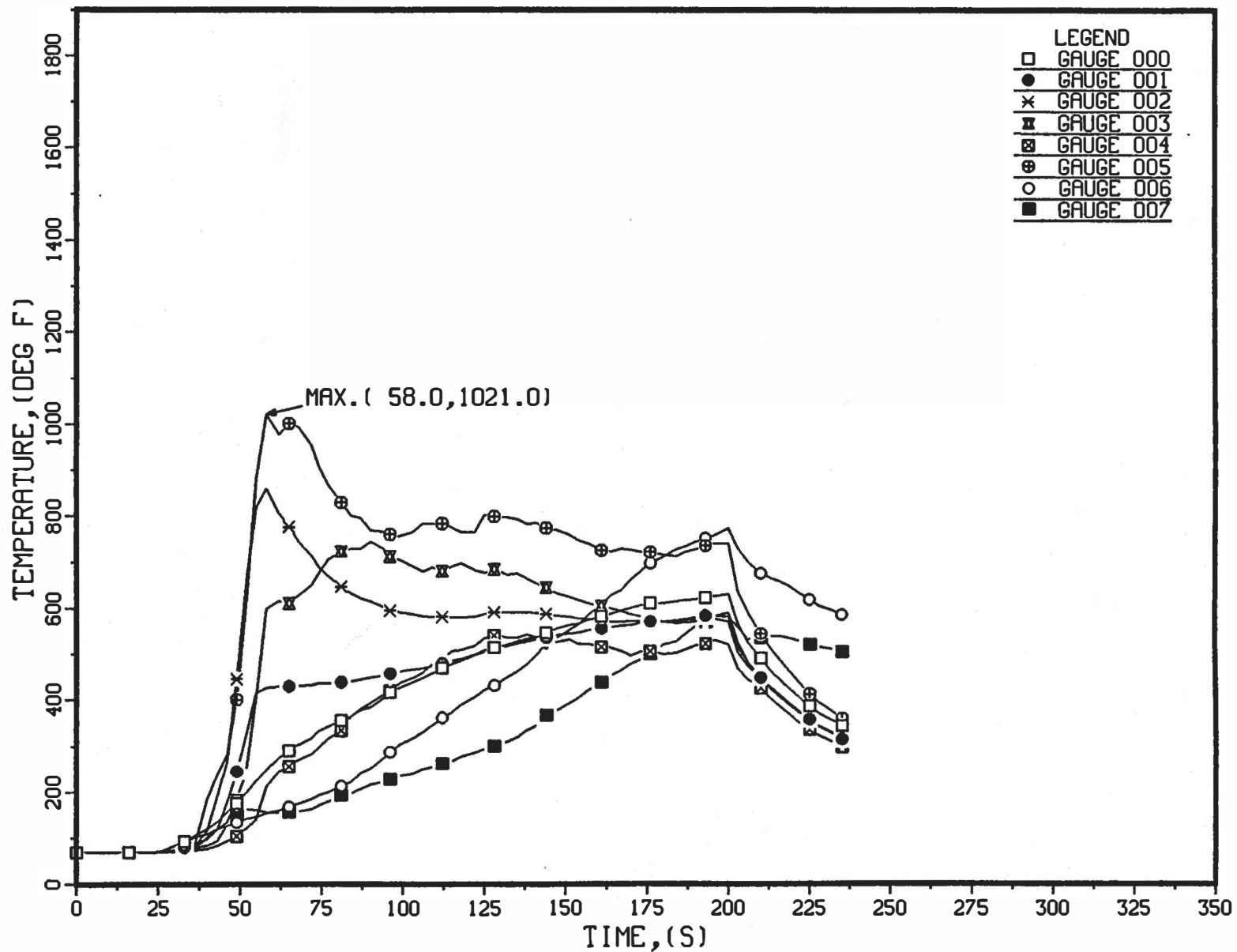

COMPOSITE, TEST116

