

SHIVA STAR INDUCTIVE PULSE COMPRESSION SYSTEM

R.E. REINOVSKY, W.L. BAKER

Air Force Weapons Laboratory

and

Y.G. CHEN, J. HOLMES, E.A. LOPEZ

Maxwell Laboratories Inc.

Albuquerque, New Mexico

ABSTRACT

SHIVA STAR

THE SHIVA STAR capacitor bank, a 120 KV parallel bank storing 9.5 MJ with a short circuit current of almost 90 MA, at the AFWL is the world's highest energy, fast capacitor bank. The approximately 3 microsecond short circuit current risetime is shortened by an inductive store/opening switch power conditioning system in which a total inductance of about 10 nH is charged with 35 MA currents. Electrically exploded conductor (fuse) opening switches are employed to interrupt the current in a few hundred nanoseconds to deliver a fast rising current to the load. The system is in operation at the AFWL and is used for a variety of plasma physics experiments. Performance of the bank and pulse compression system are discussed.

The SHIVA STAR capacitor bank is designed to meet the power system requirements of a wide variety of low impedance experimental loads which demand very large energies at high currents. Low impedance dynamic plasma devices such as the SHIVA plasma implosion system and fixed impedance devices such as the storage inductance of an inductive pulse compression system have the common properties of requiring currents of many 10's of megamperes and risetimes of a few microseconds or less. These requirements clearly point to a design philosophy that delivers the maximum manageable energy through the minimum inductance. This emphasis upon achieving the minimum inductance requires the use of large area, closely spaced conductors for interconnections which in turn suggest solid dielectric insulated transmission lines. Such solid insulated lines are most attractive for moderate voltages of 150 KV or less. Choosing such a moderate output voltage permits, in addition, the design of a machine operated in air (vs oil), which also offers the additional advantages of simplicity and economy. The moderate output voltage thus permits design of a low impedance machine which offers the largest currents for a given total energy.

INTRODUCTION

Over the last ten years the total energy needed to power state-of-the-art plasma physics and pulse power experiments has increased from a fraction of a megajoule to many megajoules. As the total energy has increased, the conventional water insulated coaxial pulse line design philosophy has become a less and less attractive approach to meet the total energy requirements and new, and advanced power conditioning concepts must be developed and employed. The SHIVA STAR system, a 9.5 MJ fast capacitor bank, was designed and built at the Air Force Weapons Laboratory to power plasma physics experiments for the AFWL Shiva X-Ray Source Technology Development Program. The system is in routine operation and experiments to explore advanced power conditioning concepts based on magnetic (inductive) intermediate energy storage are being conducted as part of the AFWL SHIVA research program. Previous systems in the SHIVA family have successfully demonstrated the use of inductive intermediate storage systems, charged from high performance capacitor banks and switched with high current (15 MA - 300 KV) fuse opening switches. The SHIVA STAR system is approximately 5 times as energetic as the previous system while retaining the same level of high performance, low inductance and high output currents. This paper outlines the characteristics of the SHIVA STAR system including its operational parameters, describes the inductive pulse compression system currently in operation on the machine, describes the potential performance of the power conditioning system, and presents results of initial operational pulse power test of the system.

Following previously successful SHIVA machine concepts, STAR is configured as a parallel connected, differentially charged bank operating at 120 KV (+/- 60 KV) output voltage. As shown in Figure 1, the machine consists of 36 modular units. Each unit contains 24 capacitors and header assemblies, 4 output switches and their associated trigger system components. The individual modules are arranged in groups of 6 around six large area parallel plate transmission lines which converge to the load region in the center of the machine. The 24 high energy density capacitors in each module are connected in 2 groups of 12 forming top and bottom half-modules which are charged to opposite polarity as shown in Figure 2.



Figure 1. SHIVA STAR system.

Report Documentation Page

Form Approved
OMB No. 0704-0188

Public reporting burden for the collection of information is estimated to average 1 hour per response, including the time for reviewing instructions, searching existing data sources, gathering and maintaining the data needed, and completing and reviewing the collection of information. Send comments regarding this burden estimate or any other aspect of this collection of information, including suggestions for reducing this burden, to Washington Headquarters Services, Directorate for Information Operations and Reports, 1215 Jefferson Davis Highway, Suite 1204, Arlington VA 22202-4302. Respondents should be aware that notwithstanding any other provision of law, no person shall be subject to a penalty for failing to comply with a collection of information if it does not display a currently valid OMB control number.

1. REPORT DATE JUN 1983		2. REPORT TYPE N/A		3. DATES COVERED -	
4. TITLE AND SUBTITLE Shiva Star Inductive Pulse Compression System				5a. CONTRACT NUMBER	
				5b. GRANT NUMBER	
				5c. PROGRAM ELEMENT NUMBER	
6. AUTHOR(S)				5d. PROJECT NUMBER	
				5e. TASK NUMBER	
				5f. WORK UNIT NUMBER	
7. PERFORMING ORGANIZATION NAME(S) AND ADDRESS(ES) Air Force Weapons Laboratory				8. PERFORMING ORGANIZATION REPORT NUMBER	
9. SPONSORING/MONITORING AGENCY NAME(S) AND ADDRESS(ES)				10. SPONSOR/MONITOR'S ACRONYM(S)	
				11. SPONSOR/MONITOR'S REPORT NUMBER(S)	
12. DISTRIBUTION/AVAILABILITY STATEMENT Approved for public release, distribution unlimited					
13. SUPPLEMENTARY NOTES See also ADM002371. 2013 IEEE Pulsed Power Conference, Digest of Technical Papers 1976-2013, and Abstracts of the 2013 IEEE International Conference on Plasma Science. Held in San Francisco, CA on 16-21 June 2013. U.S. Government or Federal Purpose Rights License.					
14. ABSTRACT THE SHIVA STAR capacitor bank, a 120 KV parallel bank storing 9.5 MJ with a short circuit current of almost 90 MA, at the AFWL is the world's highest energy, fast capacitor bank. The approximately 3 microsecond short circuit current risetime is shortened by an inductive store/opening switch power conditioning system in which a total inductance of about 10 nH is charged with 35 MA currents. Electrically exploded conductor (fuse) opening switches are employed to interrupt the current in a few hundred nanoseconds to deliver a fast rising current to the load. The system is in operation at the AFWL and is used for a variety of plasma physics experiments. Performance of the bank and pulse compression system are discussed.					
15. SUBJECT TERMS					
16. SECURITY CLASSIFICATION OF:			17. LIMITATION OF ABSTRACT	18. NUMBER OF PAGES	19a. NAME OF RESPONSIBLE PERSON
a. REPORT unclassified	b. ABSTRACT unclassified	c. THIS PAGE unclassified			

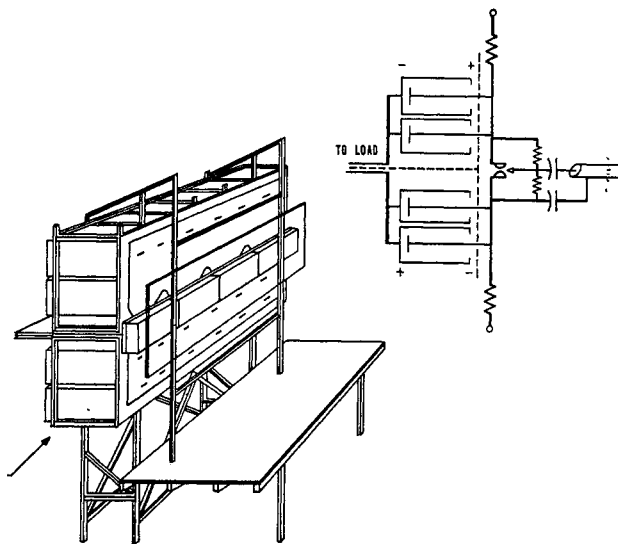

Figure 2. SHIVA STAR 1/4 MJ Capacitor Bank Module.

The module halves are switched in series with low inductance, pressurized gas rail gap switches and the output is taken between the electrically isolated frames of the upper and lower sections.

HIGH ENERGY CAPACITORS

The energy storage capacitors employed in STAR are nominally 6.05 μF at 60 KV units which were specifically developed for heavy duty operation in SHIVA STAR. As previously reported (1), a variety of capacitor designs were evaluated for performance and life expectancy under the unusually demanding discharge conditions of 250 KA discharge currents and 70% reversal. For these service conditions a capacitor employing craft paper and castor oil impregnant with a special reinforced foil arrangement and a series pad connection was selected. Based on the previous tests, of a very small sample, under these electrical conditions, this capacitor configuration demonstrated a lifetime characterized by a Weibull distribution with Weibull parameter of 2.02 and a mean lifetime of 6700 shots. Approximately 950 capacitors were manufactured to provide the 864 units installed in the SHIVA STAR system plus a limited number of spares. Additional testing was employed to confirm the continued integrity of the manufacturing process. Each unit was tested for 100 full energy (60 KV/250 KA) discharges and one representative from each manufacturing lot was tested for 1000 full energy shots. No failures were encountered during these tests. Figure 3 shows data previously reported for the small sample test with the addition of data from the larger manufacturing run. The "no failure" data establishes a lower limit on the lifetime distribution and the figure shows that the lower limit is consistent with the lifetime previously inferred for the capacitor. Thus from the distribution in Figure 3 one can estimate the lifetime of a system the size of STAR to first capacitor failure to be about 200 full energy discharges. And, furthermore, since discharges at partial energy represents significantly less wear on capacitors than do full energy discharges, capacitor lifetime is considered acceptable for the SHIVA STAR system.

SHIVA STAR CAPACITORS

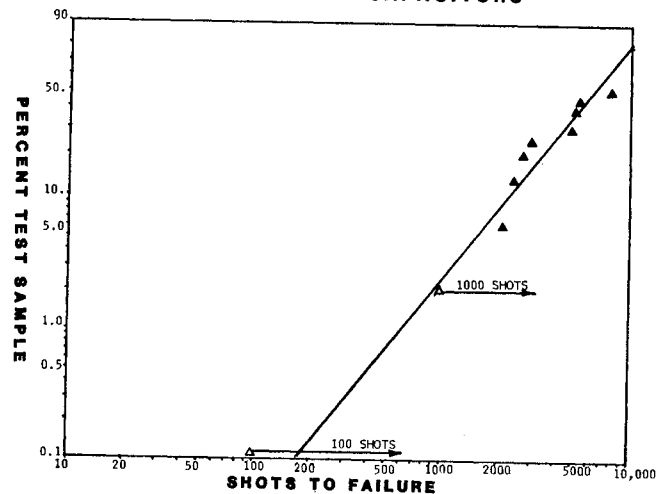

Figure 3. Lifetime data for SHIVA STAR capacitors.

LOW INDUCTANCE GAS SWITCH

The pressurized gas rail gap switch used in previous generations of SHIVA machines was improved to meet the additional requirements of higher currents and greater total charge transfer for SHIVA STAR. While electrically similar, the mechanical design was strengthened as shown in Figure 4. The machined acrylic cover was replaced and the cast epoxy base was redesigned to include not only the base but wall sections as well. This modification allowed the use of a thick polycarbonate cover slab in place of the complex machined acrylic cover. The result was a stronger and more economical switch with no compromise in electrical performance. The switch operates in a mixture of 14.5% sulfur hexafluoride in argon at pressures up to 70 psi for 120 KV operation. When triggered with a fast rising (6 - 10 KV/ns) voltage pulse from a 50 ohm source, the switch closes in multiple channels, as shown in Figure 5 with an average of 15-30 current carrying channels per switch leading to low inductance and low electrode erosion rates. Table 1 shows the parameters of the complete SHIVA STAR system.

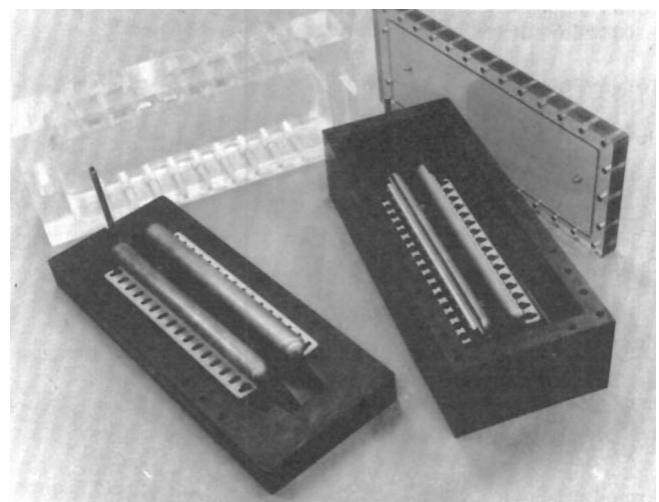

Figure 4. Pressurized gas rail gap switch: conventional (left) heavy duty (right).

RAIL SWITCH PERFORMANCE

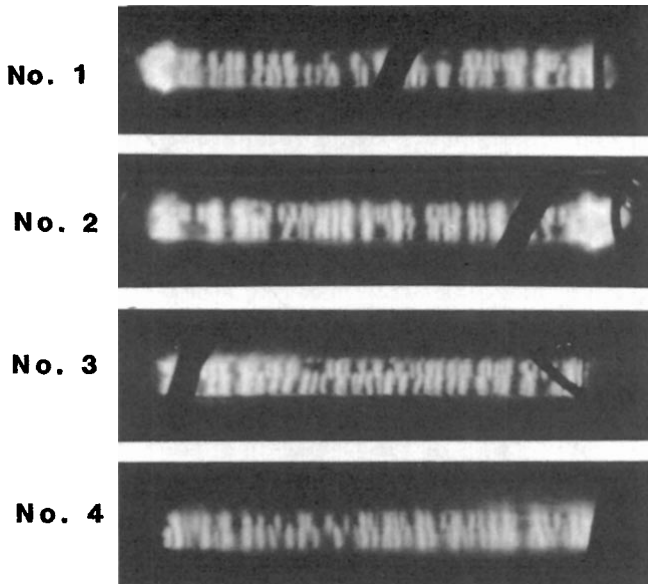

Figure 5. Multi-channel rail switch performance.

INDUCTIVE PULSE COMPRESSION SYSTEM

For applications requiring powers higher than that which can be delivered directly from a fast capacitor bank, an intermediate storage inductance can be used as a pulse conditioning system as shown in Figure 6. Current from the energy source charges the inductor and returns via the closed switch S1. When peak current is reached S1 opens (against a large inductive voltage) and S2 closes applying that large voltage

T A B L E 1

Rated Voltage	120	KV
Energy Storage Capacitors		
Units	864	
Average Capacitance	6.08	uF
Total Capacitance (differential configuration)	1313	uF
Total Energy	9.45	MJ
Output Switches		
Units	144	
Peak Current	500	KA
Peak Voltage	120	KV
System Inductance (To R = 1.45m)	2.05	nH
Current		
Peak Rated	72	MA
Short Circuit	96	MA
Quarter Period	2.5	uS
Impedance	1.25	milliohms
Series Resistance	.05	milliohms

across the load leading to a fast rising currents and high power in the load. SHIVA STAR, with its very high current capability and very low internal inductance, is an ideal charging source for such a power conditioning system.

To illustrate the potential performance of the inductive pulse compression system, the circuit in Figure 6 can be analyzed to find the current and power delivered to a fixed resistance load using an idealized model of the opening switch. The figure shows the result of such a calculation where the total storage inductance was set at 3.75 nH in order to store the maximum energy at the rated system current of 72 MA. The calculation was performed at full charge voltage with a load of 50 milliohms and a series inductance of 0.5 nH. The opening switch was described as a resistor rising as a linear ramp at a rate of 1 ohm/microsecond to a maximum resistance of 100 milliohms. The peak current in the load was 29 MA at a voltage of 1.43 MV delivering more than 40 TW to the load.

SHIVA STAR INDUCTIVE PULSE COMPRESSION SYSTEM

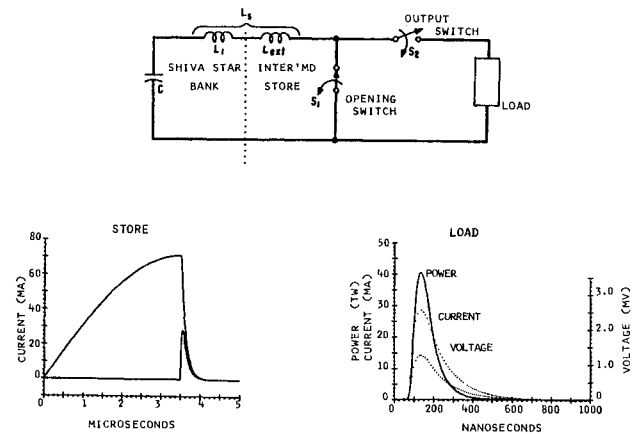

Figure 6. Inductive pulse compression circuit and circuit performance.

The physical configuration of an inductive pulse compression system which is currently operational on SHIVA STAR is shown in Figure 7. The storage inductance consists of a section of transmission line where the nominally 0.100" conductor spacing expands to 2 inches between 28 and 58 inches from the center of the machine. The inductance of this volume is approximately 8 nH which when added to the machine's 2 nH internal inductance leads to a total system inductance of 10 nH. The hexagonal shape of the machine leads to an inductor which is topologically equivalent to a complete torus. The enclosed shape makes for efficient containment of the flux with good azimuthal current symmetry with little parasitic inductance.

FUSE OPENING SWITCH

For current interrupting switches, high current, high speed fuses have been used successfully in previous AFWL work and have been extrapolated for SHIVA STAR operation. Figure 7 shows the arrangement of an array of six such fuses associated with the six sides of the storage inductor. Each fuse consists of a thin (.001" - .003") foil of aluminum or copper embedded in a porous, high melting temperature

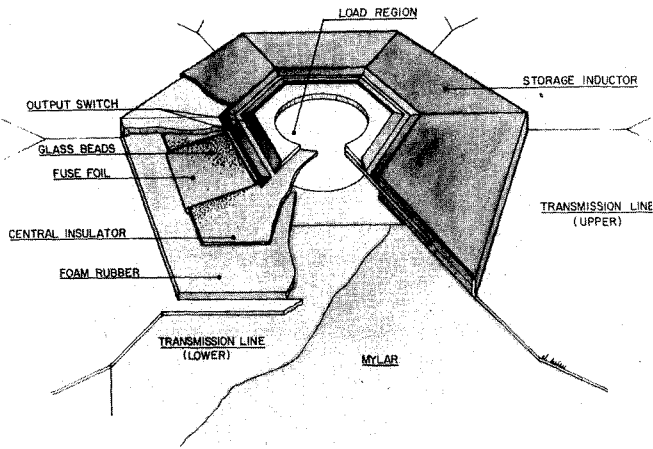

Figure 7. SHIVA STAR inductive pulse compression system.

dielectric medium. Commercially available glass beads of 100 micron diameter have been routinely used with good success. The conductor heats under the influence of the current then melts and vaporizes. The vapor mixes with the dielectric beads and cools before reaching a temperature where significant ionization occurs. Thus the fuse rises in resistance and functions like an opening switch. We have previously reported (2) the results of fuse experiments in which fuse opening switches have been employed in systems with stored energy up to 2 MJ. Figure 8 shows the performance of a fuse operated on SHIVA STAR at the 3.2 MJ energy level (and Figure 13 shows such a fuse operated at 5 MJ). As shown in Figure 8, the fuse interrupts a current of about 18 MA and exhibits about 200 milliohms resistance when fully vaporized. The fuse resistance displays a 10-15% dip which is similar to that observed in other experiments (3) and may be attributed to the onset of modest thermal ionization in the low density vapor as it is forced through the quench material. The resistivity of the fuse is seen to increase by about a factor of 500 from approximately 3 to 1500 micro-ohm-cm during operation.

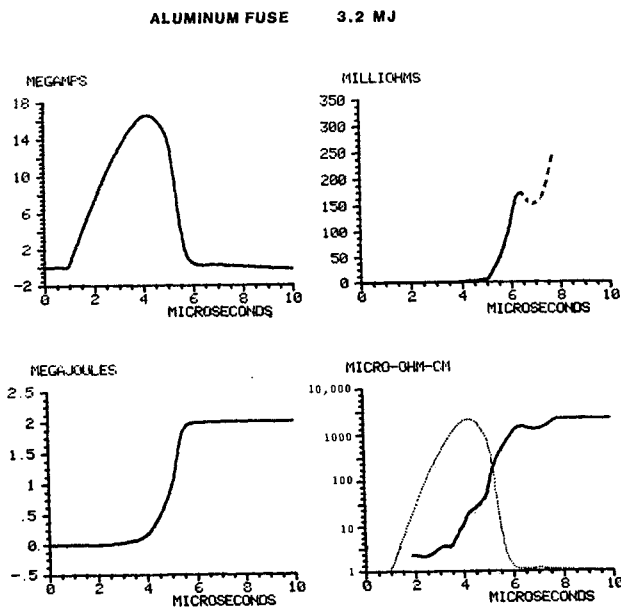

Figure 8. Aluminum fuse switch operation on SHIVA STAR.

We note that at the time of peak current, only 1.7 of the 3.2 MJ has been transferred to the inductor. The fuse resistivity has already increased by a factor of 10 over its initial value and the fuse has dissipated about 400 KJ (or more than 10%) of the initially stored energy. Thus while the fuse is an attractive (and successful) technique for interrupting very large currents, the modest resistance rise early in time and the associated energy dissipation becomes the limitation when fuses are used in very large systems.

Theoretical work has been done at the AFWL to assess the improvement in performance that can be achieved by reducing the initial temperature of the fuse and hence its initial resistivity and by surrounding the fuse with a good thermal conductor to transport heat out of the fuse during the early phases of the current rise thus suppressing the early time rise in the fuse resistance. Figures 9 and 10 show the results of computational circuit solutions in which the STAR system was charged to 3.2MJ and fuse parameters were adjusted. Three models were employed: one was drawn from empirical data for room temperature fuse operation. The second used similar data adjusted to model the material resistivity to a temperature of 77 K (liquid nitrogen). The final model was augmented by the addition of 1D unsteady heat flow to the surrounding material. The heat sink was assigned parameters characteristic of silicon carbide -- a high temperature material which combines the properties of high density, heat capacity, and thermal conductivity. Figure 9 shows the current delivered to the store when fuse dimensions were chosen to give approximately the same negative dI/dt at interruption -- a measure of equivalent performance. The figure shows that reducing the initial temperature provides a significantly higher current. The 25% increase in storage current results in a 60% increase in energy transferred to the storage inductor. A further, but much smaller increase is observed when the high heat capacity quench material is used. In Figure 10, the fuse dimensions are readjusted, this time to achieve similar (20 MA) storage currents. The calculations showed that, compared to the "normal" fuse, the cooled fuse displayed much faster interruption and high

ALUMINUM FUSE OPENING SWITCH
CALCULATED PERFORMANCE

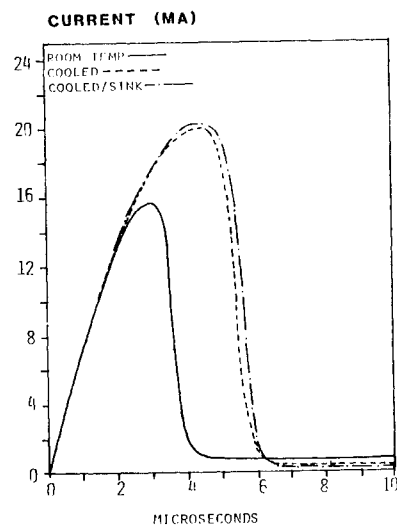

Figure 9. Calculated performance for equivalent interruption.

**ALUMINUM FUSE OPENING SWITCH
CALCULATED PERFORMANCE**

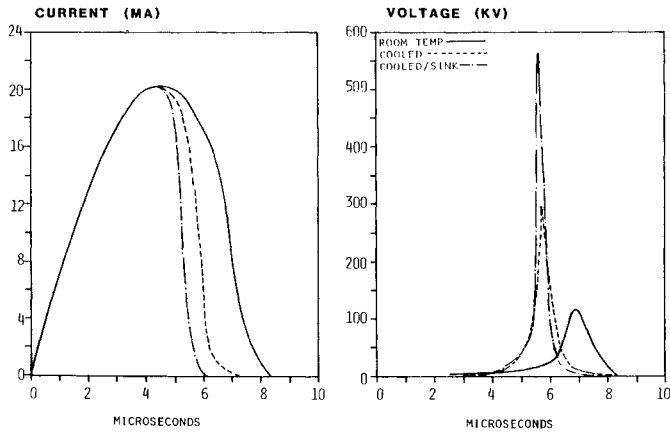

Figure 10. Calculated performance for equivalent stored energy.

voltage. The addition of the heat sink further increased the effect. In both cases the gain in performance resulted from the capability to use more geometrically favorable (longer and narrower) fuse geometries. To the extent that output voltage is a valid parameter for comparison, the cooling and heat sinking techniques may lead to a factor of 3-5 improvement in performance.

SERIES CLOSING SWITCH

The closing switch S2 which connects the load across the opening switch must be low in inductance and resistance and must close reliably at a precisely controlled point in the current interruption process. Two types of switches which have been successfully used in the inductive pulse compression system at the AFWL are shown schematically in Figure 11. A self-breaking solid dielectric breakdown switch was

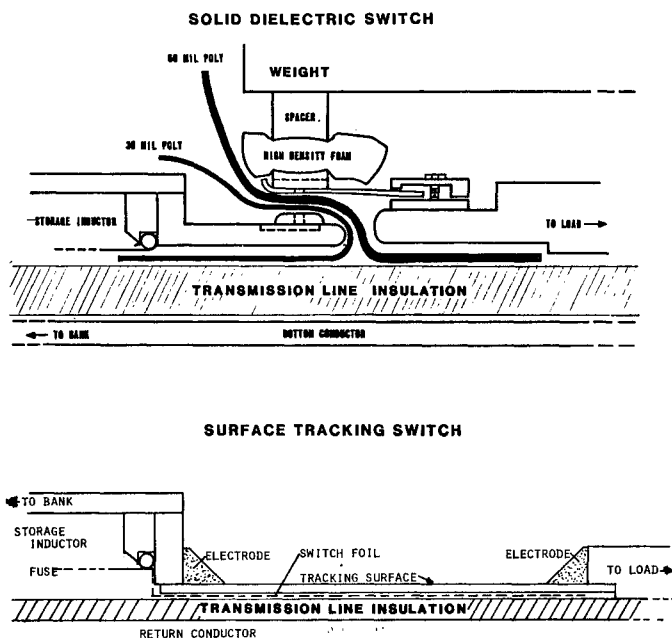

Figure 11. Series closing switch: Dielectric breakdown (top) surface (bottom).

exclusively used in the SHIVA II system and has been used successfully in SHIVA STAR. The switch consists of layers of polyethylene tightly compressed between electrodes with needle point stabs penetrating part way through the material to enhance and control breakdown. With stabs, switch closure occurs reproducibly with less than 10% variation in breakdown voltage. Multichanneling was good but at the increased energy of SHIVA STAR collateral damage from dielectric breakdown increased as did the complexity and the inductance of the six sided switch.

The second switch, a self-breaking surface tracking switch, was tested with good results. As shown in Figure 11 the switch consists of two electrodes separated by a length of solid dielectric which can, in principle, simply be the transmission line insulation. The switch closes in a number of channels which form along the surface of the dielectric. While surface tracking switches are familiar devices and are routinely used in applications with fast rising voltages and modest currents, the use of such switches in the SHIVA STAR system required extending the parameter space in which such switches were thought to be useful. For example, much higher current densities are required, on the order of 5-10 MA/meter as compared with 1 MA/meter in the previous work and, furthermore, the operation of the fuse opening switch subjects the surface switch to a long (several microsecond) voltage profile which is a significant fraction, 20 - 30%, of the desired closing voltage. A scale model experiment was constructed to evaluate surface switching for STAR applications. Figure 12 shows channel formation in the test system. The switch withstood approximately 100 KV for more than 3 microseconds before closing in multiple channels which carried a total of 0.5 MA. High speed photographs conducted on the scale model experiment confirm that streamer growth began on the anode of the switch and that multichanneling increased

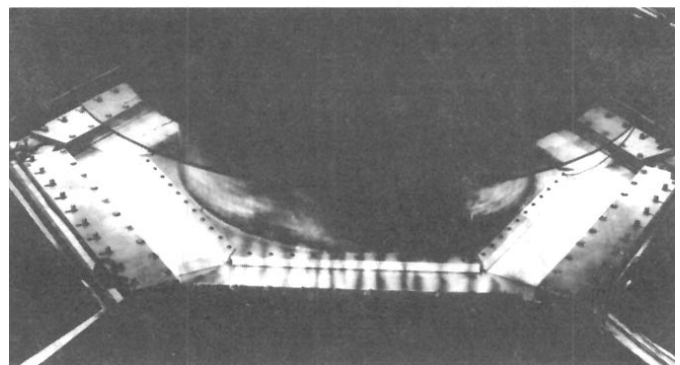
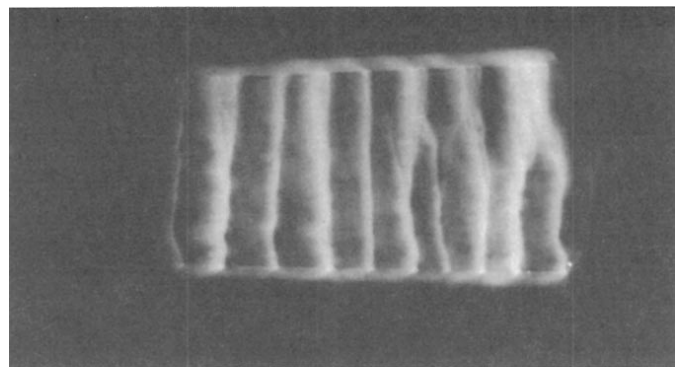

Figure 12. Multi-channel surface switch performance, model experiment (top), SHIVA STAR (bottom).

and average closure velocity decreased as capacitance experienced by the streamer growing across the surface increased. Thus the geometry shown in Figure 11, with an enhancing foil set just below the surface and connected to the cathode side of the switch produced reproducibly good results. Figure 12 shows performance of the surface tracking switch in the STAR system, where the switch carried 14 MA of current in about 100 channels at a current density of more than 3 MA/meter.

OUTPUT POWER

The SHIVA STAR system is configured to optimize the power delivered to a plasma implosion load. The system can, however, be configured to deliver maximum power to a fixed resistance load. To achieve maximum power the storage inductor is reduced to the minimum value consistent with the peak rated machine current and a load resistance is chosen to match the fuse open circuit impedance. Using fuse performance predicted by the model employed in Figure 10 and a matched resistive load, the performances presented in Table 2 was predicted. As expected, the model shows that maximum power to a resistive load is a strong function of the maximum resistance (resistivity) achieved by the fuse. Resistivities up to 1500 micro-ohm-cm have been observed, and techniques to increase maximum fuse resistivity to 4-5000 micro-ohm-cm are under investigation both calculationally and experimentally. (4) .

T A B L E 2

Initial Temperature	Final Resistivity	Load Resistance	Power
293°K	1000 μΩcm	30	6Tw
77°K	1000 μΩcm	30	12Tw
77°K	2000 μΩcm	60	16Tw
* 77°K	4000 μΩcm	120	33Tw

* Enhanced by addition of extra pressure.

SYSTEM OPERATION

SHIVA STAR has been successfully operated into plasma implosion loads, resistive dummy loads, and at full 9.5 MJ stored energy into dissipative fuse loads where fuse parameters are chosen to absorb the full system energy while producing only modest voltages. Figure 13 shows results of a test of the inductive pulse compression system operated into a fixed resistance load. The bank charge voltage was 90 KV, 5 MJ and the peak fuse current was 29 MA. Risetime into the 5 milliohm, 3 nH load is 480 ns. The test shows successful operation of an inductive pulse compression system at the highest energies yet reported.

SHIVA STAR

RESISTIVE LOAD PERFORMANCE

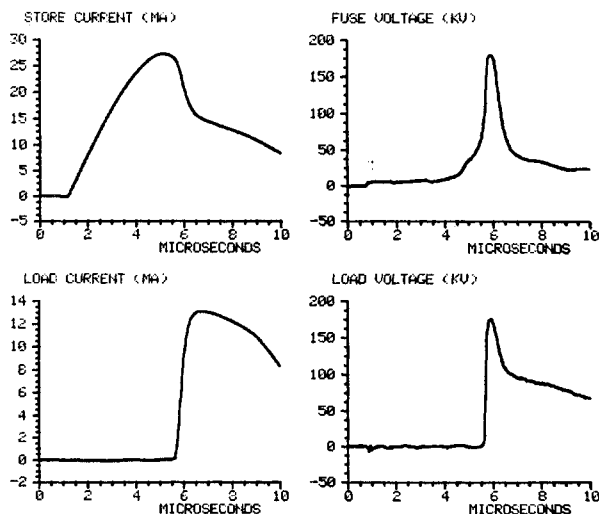

Figure 13. SHIVA STAR performance to a 5 milliohm, 3 nanohenry resistive load.

CONCLUSIONS

The SHIVA STAR system is an operational pulse power system. It is the largest fast capacitor bank system in the world and operates either directly into a low impedance load or through an inductive intermediate store pulse compression system to produce high powers and fast current risetimes to experimental load. Fuse opening switches have been successfully demonstrated at the 5 MJ energy level and several approaches for improving fuse performance are under investigation. Surface tracking switches as load isolating switches have been demonstrated at the 14 MA current level.

REFERENCES

1. D.L. Smith, R.E. Reinovsky, "High Energy Density Capacitor Testing for the AFWL Shiva", Transactions 3rd I.E.E.E. Int'l Pulsed Power Conf (Albuquerque, NM) 1981, p 467.
2. C. Stuerke, R. Henderson, D.L. Smith, R.E. Reinovsky, "Multi-Megamp, Multi-Terawatt Inductive Pulse Compression System Operation", Transactions 3rd I.E.E.E. Int'l Pulsed Power Conf (Albuquerque, NM) 1981, p 238.
3. J.C. Bueck, R.E. Reinovsky, "The Effects of Cryogenic Initial Temperatures on Aluminum and Copper Electrically Exploded Foil Fuses", Transactions 4th I.E.E.E. Int'l Pulsed Power Conf (Albuquerque, NM) 1983.
4. J.D. Watson, M.L. Hines, R.E. Reinovsky, and P.S. Levi, "Staged Explosively Driven Opening Switch Development for Explosive Flux Compression Generators", Transactions 4th I.E.E.E. Int'l Pulsed Power Conf (Albuquerque, NM) 1983.