

L. A. Rosocha, M. Kang, V. O. Romero, F. W. Van Haaften, and J. P. Brucker

University of California
 Los Alamos National Laboratory
 P. O. Box 1663
 Los Alamos, New Mexico 87545

Abstract: Aurora is an inertial confinement fusion laser system using optical angular multiplexing and a chain of four cold cathode electron beam driven KrF laser amplifiers to produce 10 to 20 kJ of optical energy.

The electron guns make use of graphite felt cathodes that range in emission area from 1,200 cm² to 20,000 cm² and are typically driven by Marx generator charged waterline PFLs of 2.7 Ω impedance that produce 650 ns pulses when switched by SF₆ insulated trigatrons. Typical cathode voltages are 300 kV to 700 kV with cathode current densities of 15 to 25 A/cm². Electron current is transported to the laser gas through metal foil or Kapton windows and a hibachi support structure. Magnetic guide fields of 1.8 to 3.0 kG are used for beam guidance.

In this paper, we will concentrate on the major electron gun components of these amplifiers: Marx generators, water PFLs, output switches, feedthrough bushings, cold cathode diodes, and magnets. All of the Aurora e-guns are similar, except that the SAM does not employ a PFL and the LAM uses two electron guns, each driven by two PFLs in parallel. The design and performance of the electron guns are described in more detail in the sections that follow.

Introduction

Aurora is a high power krypton-fluoride laser system now being constructed for inertial confinement fusion (ICF) studies at the Los Alamos National Laboratory; it will employ optical angular multiplexing and serial amplification by electron beam driven KrF amplifiers to deliver multi-kilojoule 5 ns duration laser pulses to ICF targets. The complete laser system has been previously described by Rosocha¹ and Hanlon et al.,² while the performance of the main power amplifier in the beam train, the Large Aperture Module (LAM), has been reported by York et al.³⁻⁴ The LAM has a laser aperture of 1 m x 1 m and is the largest and most energetic existing ultraviolet laser of its type so far reported, having produced in excess of 10 kJ of 248 nm laser energy when operated in a nonoptimized unstable resonator configuration. A conceptual block diagram for the Aurora system is shown in Fig. 1.

The main amplification chain for Aurora consists of four electron beam-driven KrF laser amplifiers called the Small Aperture Module (SAM), the Pre-amplifier (PA), the Intermediate Amplifier (IA), and the LAM. Table I summarizes the characteristics of these laser amplifiers.

The SAM is a double-pass amplifier that amplifies a portion (60 ns) of the entire Aurora pulse train; it has a stage gain of about 20 and delivers 5 J of uv laser light to the eight-fold encoder.

The Pre-amplifier and Intermediate Amplifier are single-pass amplifiers with similar design and gain characteristics; both have large aspect ratios L/D

**AURORA LASER SYSTEM
 Conceptual Layout
 (w/o Demultiplexer)**

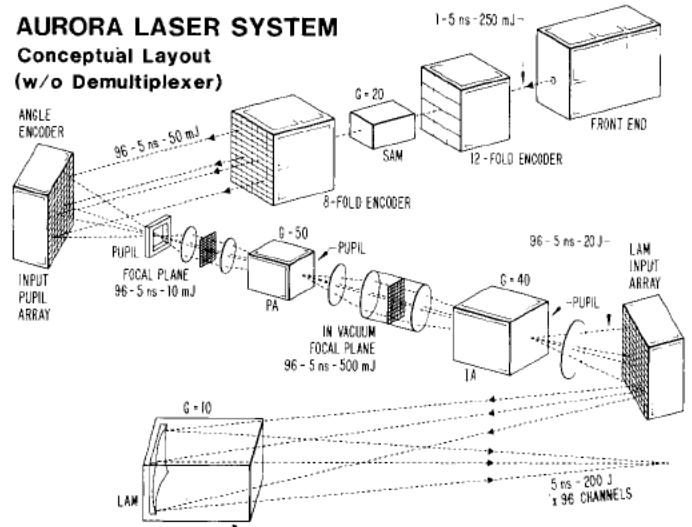

Fig. 1. Conceptual block diagram of the Aurora laser system not including the target details.

**SUMMARY OF AMPLIFIER SPECIFICATIONS
 (NOMINAL VALUES)**

UNIT	PFL PULSE LENGTH (TWO-WAY) (ns)	E-GUN VOLTAGE (kV)	E-GUN J (IN GAS) (A/cm ²)	E-GUN AREA (cm ²)	INPUT LIGHT ENERGY (J)	OUTPUT LIGHT ENERGY (J)	STAGE GAIN	CLEAR APERTURE (cm x cm)
SAM	100	300	12	12 x 100	0.25	5	20	10 x 12
PA	650	675	10	40 x 300	1	50	50	20 x 20
IA	650	675	10	40 x 300	50	2,000	40	40 x 40
LAM	650	675	12 (EACH SIDE)	100 x 200	2,000	10 - 20k	10	100 x 100

TABLE I

(length divided by laser aperture width), operate at high stage gain, are driven by a relatively low saturation flux, and are only partially filled by the input laser beams. With an expected small signal gain of 3% per cm and an absorption-limited length of 300 cm, stage gains of 50 and 40 can be achieved with the PA and IA, respectively. For a typical drive energy of 1 J at the PA input, the PA output is about 50 J and the IA output is 2 kJ.

The LAM has a smaller aspect ratio than the PA and IA, having L/D = 2. It is almost completely filled by its drive beam and operates at a fairly low stage gain of 10, since it is driven into the saturated regime by the input laser beam. For an input of 2 kJ from the IA, the LAM will produce from 10 to 20 kJ of laser energy when operated in a double-pass amplifier configuration, with optimized performance. At the output of the LAM, the multi-kilojoule laser energy will be in a 96-element, 480 ns pulse train; optical decoding of the multiplexed beam will result in the compression of this

Report Documentation Page

Form Approved
OMB No. 0704-0188

Public reporting burden for the collection of information is estimated to average 1 hour per response, including the time for reviewing instructions, searching existing data sources, gathering and maintaining the data needed, and completing and reviewing the collection of information. Send comments regarding this burden estimate or any other aspect of this collection of information, including suggestions for reducing this burden, to Washington Headquarters Services, Directorate for Information Operations and Reports, 1215 Jefferson Davis Highway, Suite 1204, Arlington VA 22202-4302. Respondents should be aware that notwithstanding any other provision of law, no person shall be subject to a penalty for failing to comply with a collection of information if it does not display a currently valid OMB control number.

1. REPORT DATE JUN 1985	2. REPORT TYPE N/A	3. DATES COVERED -			
4. TITLE AND SUBTITLE Design And Performance Of Large Area Monolithic Electron Guns For The Aurora Krf Laser System		5a. CONTRACT NUMBER			
		5b. GRANT NUMBER			
		5c. PROGRAM ELEMENT NUMBER			
6. AUTHOR(S)		5d. PROJECT NUMBER			
		5e. TASK NUMBER			
		5f. WORK UNIT NUMBER			
7. PERFORMING ORGANIZATION NAME(S) AND ADDRESS(ES) University of California Los Alamos National Laboratory P. O. Box 1663 Los Alamos, New Mexico 87545		8. PERFORMING ORGANIZATION REPORT NUMBER			
9. SPONSORING/MONITORING AGENCY NAME(S) AND ADDRESS(ES)		10. SPONSOR/MONITOR'S ACRONYM(S)			
		11. SPONSOR/MONITOR'S REPORT NUMBER(S)			
12. DISTRIBUTION/AVAILABILITY STATEMENT Approved for public release, distribution unlimited					
13. SUPPLEMENTARY NOTES See also ADM002371. 2013 IEEE Pulsed Power Conference, Digest of Technical Papers 1976-2013, and Abstracts of the 2013 IEEE International Conference on Plasma Science. Held in San Francisco, CA on 16-21 June 2013. U.S. Government or Federal Purpose Rights License.					
14. ABSTRACT Aurora is an inertial confinement fusion laser system using optical angular multiplexing and a chain of four cold cathode electron beam driven KrF laser amplifiers to produce 10 to 20 kJ of opti~ cal energy. The electron guns make use of graphite felt cathodes that range in emission area from 1,200 cm2 to 20,000 cm2 and are typically driven by Marx generator charged waterline PFLs of 2.7 n impedance that produce 650 ns pulses when switched by SF6 insulated trigatrons.					
15. SUBJECT TERMS					
16. SECURITY CLASSIFICATION OF:			17. LIMITATION OF ABSTRACT SAR	18. NUMBER OF PAGES 4	19a. NAME OF RESPONSIBLE PERSON
a REPORT unclassified	b ABSTRACT unclassified	c THIS PAGE unclassified			

energy into a 5 ns pulse suitable for fusion targets.

In this paper, we will concentrate on the major electron gun components of these amplifiers: Marx generators, water PFLs, output switches, feedthrough bushings, cold cathode diodes, and magnets. All of the Aurora e-guns are similar, except that the SAM does not employ a PFL and the LAM uses two electron guns, each driven by two PFLs in parallel. The design and performance of the electron guns are described in more detail in the sections that follow.

Figure 2 is a representative cross section for the Aurora e-guns.

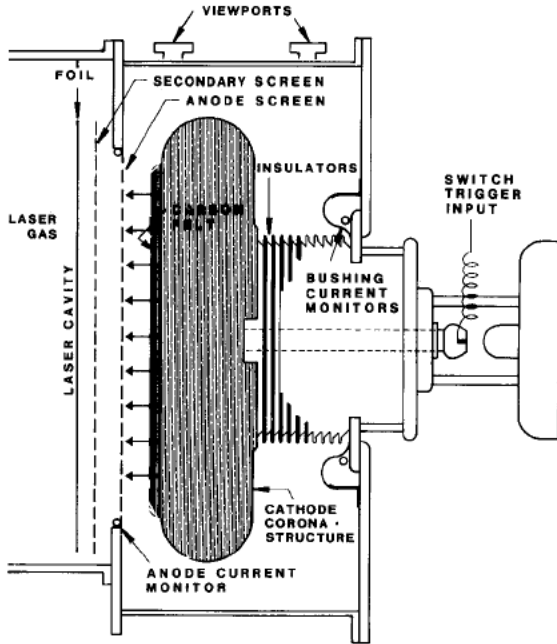

Fig. 2. Representative electron gun cross section for the Aurora e-guns. The LAM employs two PFLs for each of its e-guns in a double-sided excitation arrangement to achieve uniform pumping across its large laser aperture.

Pulsed Power Components

Marx Generator: Each amplifier contains one or more Marx generators of similar construction,⁵ except for the SAM, which is a commercial device.⁶ The PA, IA, and the LAM all employ 15-stage Marx generators in which each stage is a series combination of two capacitors. The 15 stages are individually charged in a double-ended mode to ± 60 kV in about one minute or less. When fully charged and triggered, these Marxes can erect to an open-circuit voltage of approximately 1.8 MV and approximately 1.6 MV when charging the waterline PFLs. The Marx generators for these three main amplifiers store about 150 kJ of electrical energy for each PFL to which they are connected. Table II summarizes the Marx generator characteristics for all four Aurora amplifiers.

PFLs and Output Switches: The PFLs employed in Aurora are common to the PA, IA, and the LAM; these are coaxial cylinder transmission lines using de-ionized water as a dielectric. The inner conductor has a diameter of 61 cm, the outer conductor has an

inside diameter of 91 cm, and the length of the lines is 10.8 m. The peak electric fields at the PFL negative inner conductor and positive outer conductor are 134 kV/cm and 91 kV/cm, respectively.

A water breakdown criterion due to Martin⁷ indicates that these values are approximately 60% and 90% of the negative and positive breakdown fields, respectively. Operation at 90% of the Martin breakdown stress at first seems a risk, but is justified in

MARX GENERATOR CHARACTERISTICS

AMPLIFIER	STAGES	MARX ERRECTED CAPAC. (nF)	MARX INDUCT. (μ H)	MAX (kV) CHARGE VOLTAGE	RISETIME (μ s)
SAM	7	230	0.6	± 75	30×10^{-3}
PA	14 1 2	96	5	± 60	1.8
IA	14 1 2	96	5	± 60	1.8
LAM	14 1 2	230	5	± 60	2.4

TABLE II

light of an analysis by Etlicher et al⁸ who show that it is possible to exceed the Martin criterion and operate waterlines at approximately 105% of the Martin breakdown stress. For pure water (≈ 10 M Ω -cm) of dielectric constant $k = 80$ and the above geometry, the line impedance is approximately 2.7 Ω . Each of these waterlines is connected to the diode feed bushing by an output switch of trigatron configuration similar to that reported by Markins.⁹ The switch is pressurized with SF₆ to a working pressure of between 3.5 and 5.5 atmospheres absolute. Switches of this type typically have an inductance on the order of 100 nH/MV, so these switches are expected to have an inductance of 0.1 μ H or larger. When the output switch fires, the 325 ns one-way electrical length waterline delivers a 650 ns long pulse of one-half the PFL charge voltage into a matched load. We have carefully engineered the output switches for low-jitter performance and we have measured typical jitters of ± 13 ns (one sigma) when firing the PFLs into both dummy loads and cold cathode diodes - this is quite sufficient for our needs.

Electron Gun Assemblies: The electron guns provide the energetic electron beams that drive the laser gas gain medium; these guns consist of the following main components; diode feed bushing, cathode corona shell, emitter, hibachi, and foil. These components are housed in a vacuum enclosure and maintained at a pressure suitable for the operation of the field emission cathode and the feed bushing (5×10^{-6} torr). Any of the electron guns (SAM, PA, IA, or LAM) is representative of the design and construction concepts used for Aurora, except that the SAM is considerably smaller than the other three and differs in some conceptually unimportant details.

The diode feed bushing serves to make the electrical interface from the oil-insulated output switch housing to the cathode vacuum environment. This bushing is of typical high voltage design, using 45 $^\circ$ -angled-surface acrylic insulator rings alternating with aluminum field-grading rings. The cathode corona shell attaches to the end of this

bushing and the graphite felt emitter surface is attached to a contoured boss on this shell. Graphite felt emitters are used since they exhibit low ignition voltage and good spatial uniformity of electron emission. The emitter area for the SAM is 12 cm x 100 cm; the A-K gap is 3.5 cm, which gives an 8 Ω diode impedance. It operates at nominal voltage and cathode current density of 300 kV and

30 A/cm², respectively. The PA and IA electron guns are almost identical: both have approximately 8 cm A-K gaps and 40 cm x 280 cm emitter areas, although the PA beam is masked to produce a 20 cm x 280 cm beam area compatible with its smaller laser aperture. The LAM cathodes have emitter areas of 100 cm x 200 cm and an A-K gap of about 7.5 cm. The PA and IA diodes, are designed to match the PFL impedance of 2.7 Ω and operate at a nominal cathode voltage of 675 kV and a nominal space-charge-limited current density of 22 A/cm² at the cathode. The LAM design is 675 kV and 25 A/cm², which matches the 1.35 Ω impedance of two PFLs in parallel.

The interface between the diode vacuum chamber and the laser gas volume is provided by a titanium or Kapton¹⁰ foil of nominal 50 μ m (2 mil) thickness. The foil is supported by an aluminum hibachi structure that typically has a geometrical transmission of 80%. The open-cell hibachi dimensions range from 13.5 cm x 1.6 cm for the SAM to 23.8 cm x 3.6 cm for the LAM. The laser chambers contain the Kr/F₂/Ar laser gas mixtures at typical pressures in the range 600 to 1200 torr; the open-cell sizes and hibachi depths are designed to withstand the mechanical stresses due to these pressure differentials.

Magnets: Quasi-Helmholtz-pair electromagnet coils on all amplifiers but the SAM provide magnetic fields that stabilize the electron beams against self-pinching and reduce collisional diffusion losses in the laser gas volume. The coils are symmetrically placed about the center of the laser chambers and provide almost uniform magnetic fields parallel to the electron beam paths. The PA and IA coils have major and minor diameters of 5.5 m and 1.65 m, respectively; the LAM has a major diameter of 4.2 m and a minor diameter of 2.6 m. Typical fields are 1200 to 1800 Gauss for the PA and IA and 2,000 to 3,000 Gauss for the LAM. The usual operating waveshape is a few second ramp from zero field to the operating level, a few second constant field, followed by a ramp down to zero field.

Diode Model

The simple cold-cathode diode model that we use to describe the Aurora electron guns is based on the Langmuir-Child space-charge limited electron diode theory.¹¹ For a cathode of rectangular geometry, the cathode current and voltage are related by the following expression:

$$I = k (l w / d^2) V^{3/2} \quad (1)$$

where I is the cathode current in amperes V is the cathode voltage in volts, l is the cathode length, w is the cathode width, d is the A-K gap spacing, and the constant $k = 2.34 \times 10^{-6}$ for the above set of units.

Closure of the A-K gap is taken into account by means of the following expression

$$d = d_0 - v_c t \quad (2)$$

where d_0 is the initial A-K gap spacing, v_c is the closure velocity, and t is the time after cathode ignition. The closure velocity depends on the magnitude of the external applied magnetic field B through the following approximate formula¹²

$$v_c = a + b B^{4/9} \quad (3)$$

where a and b are constants with approximate values of -0.088 and 1.41, respectively; the units are v_c in cm/ μ s and B in kG.

A description of the electrical operation of the electron guns is formulated by coupling Eqs. 1 to 3 to an equivalent circuit for the e-gun and Marx.

The coupled circuit and diode equations are solved by means of the NET-2 circuit analysis program.¹³ This program describes the circuit by means of appropriate circuit and transmission line differential equations. Figure 3 below shows the results of a circuit calculation for the LAM compared with experimental measurements of the e-gun voltage and current.

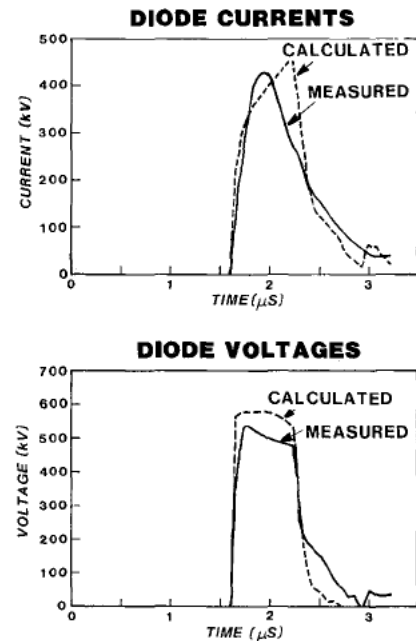

Fig. 3. Comparison of calculated (NET-2) and measured waveforms for the LAM cathode voltage and current. The PFL charge voltage was 1.16 MV at a switchout time of 1.8 μ s. This switchout time is approximately 2 PFL transit times before the peak PFL ringup voltage.

Initial Faraday Cup Data

Work is currently underway to measure the spatial and temporal distributions of the e-beam current from the Pre-amplifier e-gun. The Faraday cups are of similar design to those of Pellinen¹⁴ and each has a collector area of 60 cm². The cups are mounted on a ground plane 3 cm from the anode grid and measures the raw diode e-beam current. Figure 4 shows the spatial distribution of the e-beam over the cathode emitter. Magnet current was

1050A; considerable pinching is evident at this applied magnetic field of -1.2 kG. However, the distribution across the hibachi slots is uniform and is sufficient for our needs. Voltage on the diode was measured at 482 kV (495 kV calculated).

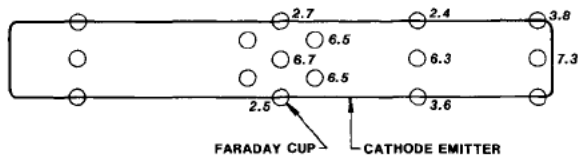

Fig. 4. Preliminary measurements of the spatial distribution of the preamplifier cathode current density. Operation at higher voltages and B fields is expected to produce a more uniform distribution.

Energy Deposition

We have measured the electron beam energy deposited in the Kr/F₂/Ar laser gas mixture in the LAM laser chamber by means of pressure-jump calorimetry. Since the e-beam energy is deposited in the gas in a short time ($\sim 0.5 \mu\text{s}$), the deposition process can be considered adiabatic. Therefore, the deposited energy can be related to C_v (the specific heat at constant volume), the laser chamber volume, and the pressure rise that results from the increase in thermal energy of the gas. The pressure rise is measured with a commercial capacitance manometer. For a gas mixture that is predominantly Ar and a LAM volume of approximately 4.7 m^3 , the energy vs pressure relationship is about 1 kJ/torr . Figure 5 shows the energy deposited in the LAM laser gas as a function of Marx charge voltage. The deposited energy should be proportional to $V^{5/2}$, since the power is given by IV and $I \sim V^{3/2}$ for a Langmuir-Child diode. The solid line on the log-log plot has a slope of $5/2$; within our experimental error, the data agrees well with the calculated slope.

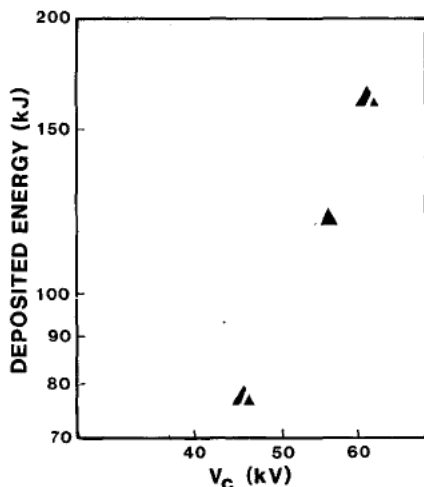

Fig. 5. Measured e-beam energy deposition into the LAM laser gas as a function of Marx charge voltage.

Summary

The Aurora laser system is now in the final stages of assembly and testing. In this paper, we have presented details related to the designs for the large area electron guns that energize the four KrF laser amplifiers that make up the serial ampli-

fier chain. We have also presented data on the calculation and measurement of electron gun cathode current, cathode voltage, current density, electron energy deposition in the laser gas, and preliminary measurements of cathode current spatial distribution. A simple diode model has been used to calculate cathode currents and voltages in reasonable agreement with measurements.

References

- [1] L. A. Rosocha, "Aurora: A Short-Pulse Multi-kilojoule KrF Inertial Fusion Laser System," Digest of Technical Papers, CLEO '85, p. 186, May 1985.
- [2] J. Hanlon, J. McLeod, J. E. Sollid, W. Horn, III, R. Carmichael, B. Kortegaard, and L. A. Rosocha, "The Aurora Project: Optical Design for a Kilojoule Class KrF Laser," Program of Southwest Conf. on Optics, Albuquerque, New Mexico, Paper TB115, March 4-8, 1985.
- [3] G. W. York, Jr., S. J. Czuchlewski, E. T. Salesky, and L. A. Rosocha, "Energy Extraction and Gain Measurements on the Los Alamos Large Aperture KrF Laser," Presented at Lasers '84, McLean, Virginia, p. 27-29, November 1984.
- [4] G. W. York, Jr., S. J. Czuchlewski, L. A. Rosocha, and E. T. Salesky, "Performance of the Large Aperture Module of the Aurora Krypton Fluoride Laser System," Digest of Technical Papers, CLEO '85, p. 188, May 1985.
- [5] Kenneth B. Riepe, L. L. Barrone, K. James Bickford, and Glen H. Livermore, "Antares Prototype 300-kJ, 250-kA Marx Generator," Los Alamos National Laboratory report, LA-8491, January, 1981.
- [6] Modified "Excitron" electron beam driven KrF laser, built by Maxwell Laboratories, San Diego, California.
- [7] J. C. Martin, "Nanosecond Pulse Techniques," Internal Report SSWA/JCM/704/49, AWRE, Aldermaston, England, 1970 (unpublished).
- [8] B. Etlicher, N. Camarcat, C. Bruno, G. Raiboisson, and A. Perronnet, "Scaling of the J. C. Martin Breakdown Equations to Generators of the 1-TW Class," Digest of Technical Papers, 4th IEEE Pulsed Power Conf., p. 331.
- [9] D. Markins, "Command Triggering of Synchronized Megavolt Pulse Generators," IEEE Trans. Nucl. Sci., NS-18, 296 (1971).
- [10] Kapton, polyamide film, trade name of E. I. duPont de Nemours and Co., Inc., Wilmington, Delaware.
- [11] I. Langmuir and K. Blodgett, "Currents Limited by Space Charge Between Coaxial Cylinders," Phys. Rev., 22, 347 (1923).
- [12] J. H. Jacob, Science Research Corp., Cambridge, Massachusetts, Private Communication.
- [13] Allan F. Malmberg, "NET-2 Network Analysis Program," US Army Materiel Command, Harry Diamond Laboratories, Contract DAAG39-70-C-0050.
- [14] D. Pellinen, "A High Current, Subnanosecond Response Faraday Cup," Rev. Sci. MS., Vol 41, No. 9, p. 1347-1348, Sept 1970.