

James S. Buff
Mission Research Corporation
1720 Randolph Road, S. E.
Albuquerque, New Mexico 87106

and

Robert E. Reinovsky
Air Force Weapons Laboratory/NTYP
Kirtland Air Force Base
New Mexico 87117

Introduction

In the past, the Air Force Weapons Laboratory (AFWL) has developed inductive pulse compression techniques using fuse opening switches [1]. While these techniques produced reasonable circuit efficiency at the energy level of the 1.9 MJ SHIVA capacitor bank, their inherent losses become more significant at the 9 MJ energy level of the SHIVA STAR capacitor bank. Hence, there has been recent interest in considering plasma flow switches, [2] as alternatives to fuses as opening switches.

Because the run down time for the plasma flow switch is quite long ($\sim 5 \mu\text{s}$) in the SHIVA STAR system, ablation of material from the wall of the vacuum transmission line in regions near the switch is of particular concern. Recent calculations by McCullough at AFWL, [3] have shown that ultraviolet radiation which can be characterized by a 10 eV blackbody spectrum, will emanate from the switch during the run down phase. It is the purpose of this report to investigate the ablation from the wall of the power feed and the switch. Previous studies [4-6] have investigated wall ablation in the vacuum power feed for fuse driven implosions (timescales $\sim 0.3 \mu\text{s}$).

The principal conclusions, subject to some reservations, are as follows for copper and alumina (Al_2O_3) walls.

1. During the rising portion ($\dot{I} > 0$) of the current pulse, plasma will rapidly blow off the wall to a distance of approximately 1/2 cm and remain roughly stationary until the current starts to fall. The thickness of the blowoff region is roughly proportional to the boundary radiation temperature.
2. During the falling portion ($\dot{I} < 0$) of the current pulse, the plasma expands at velocities of order 1 cm/ μs across the gap.

For an aluminum wall, the blowoff distance is much greater (a few cm).

The major uncertainty in our calculations is the radiation which emanates from the plasma flow switch. For example, if there is significant radiation from the switch while the current is low, the plasma from the walls will expand to distances much greater than 1/2 cm before it is pushed back by the magnetic field.

Method and Selection of Parameters

Fully two-dimensional calculations of the plasma flow switch and of the blowoff in the vacuum feed behind the switch are needed, but these are beyond our capability at the present time. So, the approach here is to define a one-dimensional MHD radiation calculation which is a reasonable approximation for the anticipated experiments. As the region of the transmission line near the plasma flow switch will be subject to the most intense radiation, it is this region only that we shall model. Except for the radiation field from the plasma flow switch, the other parameters can be chosen with some confidence.

An approximation for the anticipated current pulse is as follows. The current rises linearly to 15 MA in 5 μs , remains constant for 1 μs , and falls linearly in 5 μs . Figure 1a shows a typical flow switch configuration with a boundary wall carrying current and illuminated by radiation. The equivalent 1D geometry used in the calculation is shown in Figure 1b.

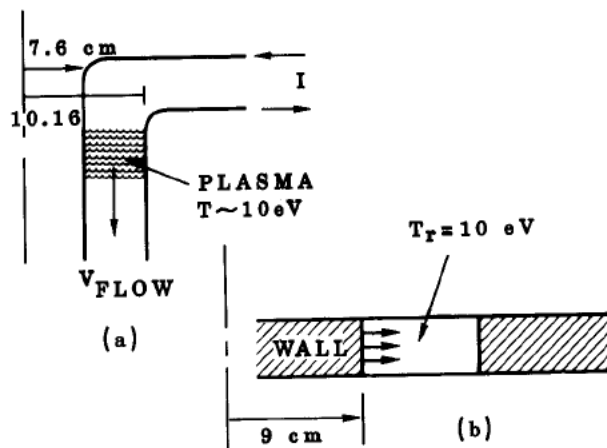

Figure 1. a) Sketch of experimental configuration, b) sketch 1D calculation.

Cylindrical symmetry with B-theta fields only are assumed. Calculations are only shown for the inner surface. A similar blowoff is expected at the outer surface of the feed. A radius of 9 cm is assumed for all calculations. The wall is initially at solid density and room temperature.

A blackbody radiation field of temperature T_R , which may be a function of time, is applied at the outer boundary. As mentioned above, this is the only input parameter which is poorly known. The radiation temperature $T_R(t)$ will be more fully described in the results section. Maximum values are in the range 7-13 eV. All calculations are performed with the one dimensional radiation MHD code MACH1 [7, 8].

Results For The Reference Model

Our approach is to present the results for one model (hereafter called the reference model). In the next section, calculations in which the input parameters were varied will be summarized. More detailed results from the reference model are given in [9].

Besides the parameters discussed, we need to specify the radiation at the outer boundary and the wall material. Some calculations at AFWL [3] show that the radiation from the switch is low for the first few microseconds and then rises sharply to about 10 eV. So for the reference model, we assume that there is no ablation during the first two microseconds of the current pulse. At time $t = 2 \mu\text{s}$, a blackbody radiation field of temperature 10 eV is suddenly turned on. A current of 6 MA is flowing in the circuit at this time.

Report Documentation Page

Form Approved
OMB No. 0704-0188

Public reporting burden for the collection of information is estimated to average 1 hour per response, including the time for reviewing instructions, searching existing data sources, gathering and maintaining the data needed, and completing and reviewing the collection of information. Send comments regarding this burden estimate or any other aspect of this collection of information, including suggestions for reducing this burden, to Washington Headquarters Services, Directorate for Information Operations and Reports, 1215 Jefferson Davis Highway, Suite 1204, Arlington VA 22202-4302. Respondents should be aware that notwithstanding any other provision of law, no person shall be subject to a penalty for failing to comply with a collection of information if it does not display a currently valid OMB control number.

1. REPORT DATE JUN 1985	2. REPORT TYPE N/A	3. DATES COVERED -			
4. TITLE AND SUBTITLE Wall Ablation Models For Plasma Flow Switches		5a. CONTRACT NUMBER			
		5b. GRANT NUMBER			
		5c. PROGRAM ELEMENT NUMBER			
6. AUTHOR(S)		5d. PROJECT NUMBER			
		5e. TASK NUMBER			
		5f. WORK UNIT NUMBER			
7. PERFORMING ORGANIZATION NAME(S) AND ADDRESS(ES) Air Force Weapons Laboratory/NTYP Kirtland Air Force Base New Mexico 87117		8. PERFORMING ORGANIZATION REPORT NUMBER			
9. SPONSORING/MONITORING AGENCY NAME(S) AND ADDRESS(ES)		10. SPONSOR/MONITOR'S ACRONYM(S)			
		11. SPONSOR/MONITOR'S REPORT NUMBER(S)			
12. DISTRIBUTION/AVAILABILITY STATEMENT Approved for public release, distribution unlimited					
13. SUPPLEMENTARY NOTES See also ADM002371. 2013 IEEE Pulsed Power Conference, Digest of Technical Papers 1976-2013, and Abstracts of the 2013 IEEE International Conference on Plasma Science. Held in San Francisco, CA on 16-21 June 2013. U.S. Government or Federal Purpose Rights License.					
14. ABSTRACT					
15. SUBJECT TERMS					
16. SECURITY CLASSIFICATION OF:			17. LIMITATION OF ABSTRACT SAR	18. NUMBER OF PAGES 4	19a. NAME OF RESPONSIBLE PERSON
a REPORT unclassified	b ABSTRACT unclassified	c THIS PAGE unclassified			

Figure 2 shows curves for the temperatures (radiation, ion and electron temperatures), pressure (gas and magnetic), velocity, density, and magnetic field at time $t=3 \mu\text{s}$ after application of radiation. There is a solid density copper wall extending from 8.9 to 9 cm. The low density blowoff region extends to 9.45 cm, where there is another sharp drop in density. The maximum velocity is 0.2 cm/ μs at a radius of 9.1 cm; the outermost part of the blowoff is barely moving. The temperature in the blowoff region is about 10 eV--the same as the outer boundary. About 1/3 of the current is flowing in the blowoff region.

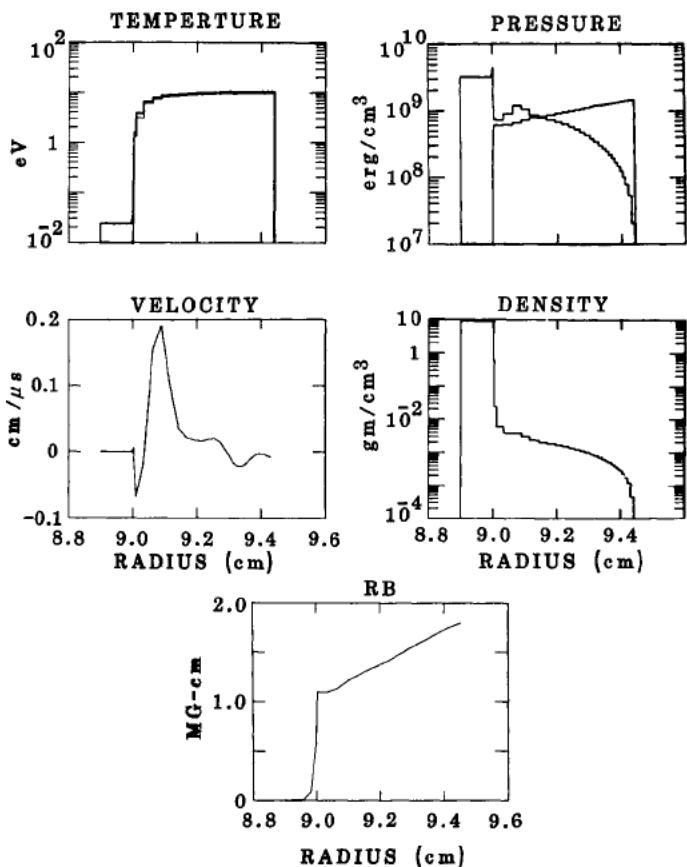

Figure 2. Diagnostic plots for the reference model at time 3 μs .

Figure 3 is a diagnostic plot at time 5 μs and should be compared to Figure 2. The density plots in Figures 2 and 3 are remarkably similar; the blowoff region extends to 9.5 cm in both plots. At $t=5 \mu\text{s}$, the velocity is computationally consistent with zero velocity. Thus, we have the somewhat surprising result that, at least in this case, the outer part of the blowoff region is changing very little while the current is rising.

Figure 4 shows the velocity and radius as a function of time for 4 selected zones. These history plots show that after the initial rapid blowoff, the outer part of the blowoff is almost stationary from 2.5 to 5.0 μs . There is a small increase in radius during the flat part of the current pulse. The plots show that the blowoff region rapidly expands during the falling portion of the current pulse. At 8 μs , the blowoff region extends to 10.25 cm and the peak velocity is 0.55 cm/ μs . At 9 μs , the blowoff has moved to 11 cm. Even a 4 cm gap would be closed at this time.

Variations on the Reference Model

In Reference [9], results from seven other models are presented in some detail. Space limitations in this paper dictated that only highlights from these

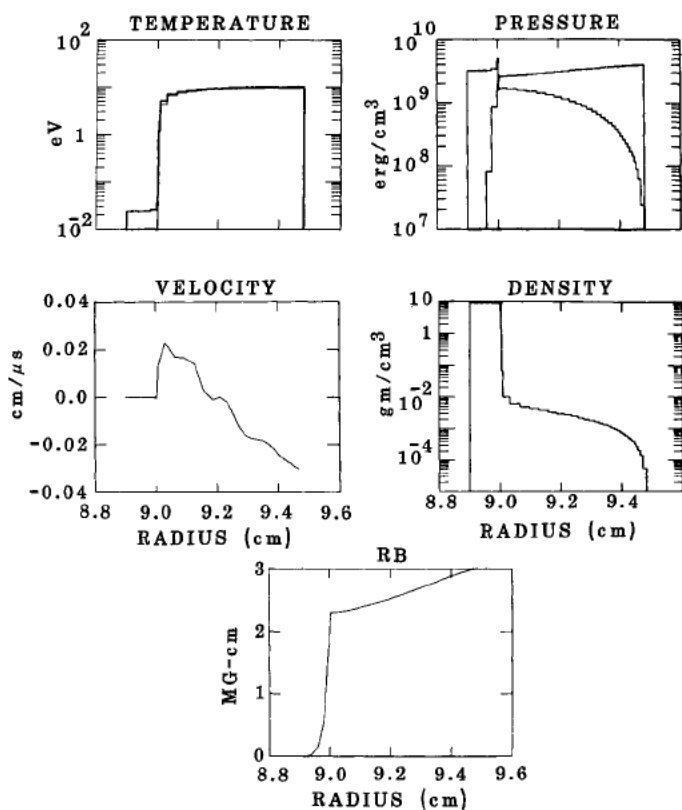

Figure 3. Diagnostic plots for the reference model at 5 μs .

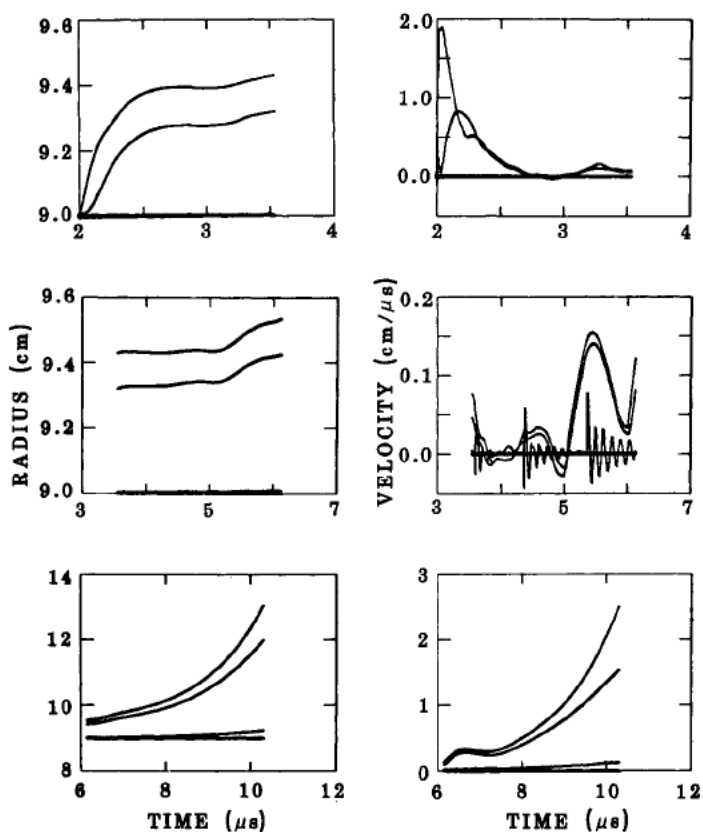

Figure 4. Radius and velocity histories for selected zones from the reference model. The zones are initially located 1.21×10^{-6} cm, 1.10×10^{-5} cm, 1.90×10^{-4} and 1.23×10^{-3} cm inward from the outer surface.

models be presented below. We will be happy to send copies of [9] upon request.

Model 2 is identical to the reference model, except that the boundary radiation temperature rises and falls as the current rises and falls. The results are very similar to the reference model. Model 3 is an extreme case where the 10 eV radiation is turned on at $t = 0$ when the current is zero. The plasma is blown off more than 4 cm before it is pulled back by the magnetic field. While the plasma is pulled back to 1/2 cm by 5 μs , oscillations dominate this model and comparisons with the reference model are difficult to make. Models 4 and 5 are identical to the reference model except that the incident blackbody radiation field is 7 eV and 13 eV respectively. The equilibrium blowoff radius scales roughly as the boundary temperature. Model 6 is identical to the reference model except that the wall material is alumina (Al_2O_3). The blowoff extends to slightly larger radii, and the density in the blowoff region is less. Radius and velocity histories are shown in Figure 5. Model 7 has a thin layer of CH on the surface. There is little change in behavior compared to the standard model. Thus a thin layer of hydrocarbon contaminate on the surface of the power feed is unlikely to be a problem. The wall material is aluminum in Model 8. The blowoff is much more severe in this case than in the corresponding copper or alumina models. The blowoff extends to more than 2 cm at 2 μs . The physical reason for this different behavior is a large difference in opacity.

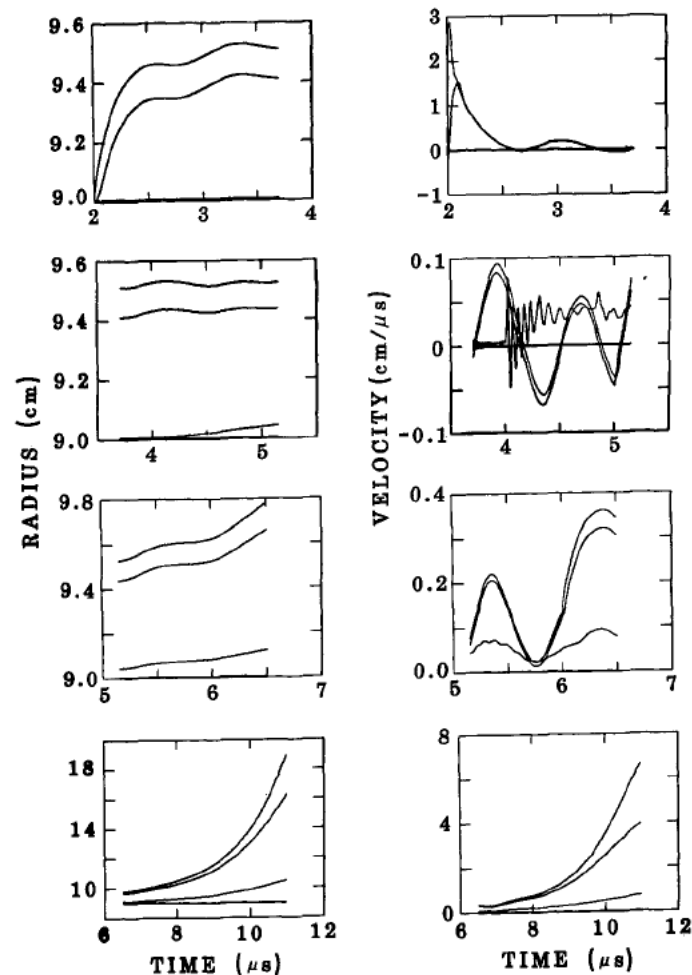

Figure 5. Radius and velocity histories for selected zones from Model 6 (Al_2O_3).

Experimental Comparison

While the calculations reported in this paper were conducted for the specific geometry described in Figure 1, some recent experiments conducted at AFWL in similar, but not identical, geometries may be compared with the calculational results. In these experiments, an imploding foil 12.15 cm in initial diameter and driven by the SHIVA STAR capacitor bank charged to 3.5 MJ is the radiation source. The current rises to about 15.5 MA in just over 4 microseconds, after which the increasing impedance of the foil implosion begins to reduce the current.

For these experiments, the vacuum gap power feed to the implosion consists of parallel aluminum disk lines whose surface has been commercially anodized to produce an almost pure (but structurally porous) alumina skin layer. The gap spacing in the line varied from 1/2 inch to 1.1 inch over several experiments. Current transport is measured in the vacuum line by Rogowski loop current monitors embedded in the feed at several radial stations.

Closure of the feed by the ablated plasma is marked by differences in the current measured by the current monitors at different stations. In the case of hard (constricted arc) break-downs the current monitors can localize the closure point quite precisely. In the case of distributed closure, very careful observation of the current data is required to discern the locations and times of gap closure.

Table 1 shows the apparent closure time observed in the experiment for three gap spacings. Breakdowns were identified by the (sometimes subtle) deviations of one current monitor from another at a different station. It is obvious that over the range of parameters explored, gap closure occurred only after current peak (falling part of the current delivery) and at later and later times as the gap is increased.

The table also shows how far the ablated material would have been expected to advance according to our model. Comparisons were made by identifying peak current in the experiment with the beginning of the downward sloping current (6.0 μs) in the calculations. Thus, the appropriate times for the comparison are obtained by adding 6 μs to the time from peak current to closure measured in the experiment. Figure 5 is then used to determine the advance of the ablated material from an alumina surface. We observe, of course, that in the experiment the gap closes from both sides.

Thus, we compare twice the last column in the table with the first column and are immediately surprised by the degree of correspondence between model and experiment. The correspondence is all the more surprising when we note the radiation field present in the experiment is likely neither precisely 10 eV nor constant in time, and the characteristic radius of the breakdown, as determined by the current monitors, is significantly larger (by perhaps a factor of 2) than the 9 cm used in the calculations. However, since remarkably similar correspondences are noted in each of three experiments, the results are somewhat more than simply fortuitous.

The results, although admittedly preliminary in nature lend credence to the results predicted by the model previously discussed.

Discussion

For parameters appropriate for plasma flow switches on the SHIVA STAR system, wall plasma will blow off of the region of the vacuum power feed near the switch to distances of about 1/2 cm during the rising ($I > 0$) portion of the current pulse. The blowoff distance scales roughly linearly with the radiation temperature incident on the walls in the models considered here. The blowoff radius is determined by the balance of forces due to gas pressure gradients and of forces due to current flowing in the blowoff region (Lorentz force). It is remarkable that an "equilibrium radius"

exists at all, and it is equally remarkable that it scales roughly with the incident radiation temperature, because the models are not steady state. The current is rising. The amount of mass in the blowoff region is rising. The flux of radiation through the blowoff region is decreasing. The fraction of current flowing in the blowoff region is strongly dependent on the gas temperature. It is likely that one could develop a simple analytic model based on assumptions made from looking at the computational results. We have not tried to do this yet, although it would be desirable to do this in the future.

If the walls are subject to intense radiation while the current is low, plasma can blow off the walls to distances much greater than 1/2 cm. The magnetic field is not strong enough to stop the flow. Plasma flow switch designs in which the gun plasma is heated to high temperatures while the current is low should be avoided. (Such a situation could arise in a long switch where the mass driven down the gun is low.)

Blowoff material will expand across the gap during the falling portion of the current pulse ($i < 0$). The expansion is slow when the current first starts to fall, but velocities of order 1 cm/ μ s are reached when the current has fallen to 1/2 peak value. Thus, switching should be completed before the current has fallen much. This computational result is in general agreement with experiments.

The plasma blowoff is not very sensitive to the wall material chosen. Models with alumina walls had 10-20 percent greater blowoff distances than models with copper walls. A thin layer of hydrocarbon contaminant on the wall surface did not significantly change the results. The blowoff was, however, much more severe in the aluminum models. Thus, aluminum would be an especially poor choice of material for the vacuum power feed.

Because of uncertainties in material properties at low temperatures, our results here should be compared in detail with experiment and with other calculations. This has not been completed yet. However, designs of plasmas flow switches and the vacuum power feed near the switch typically have gap spacings of 2-3 cm. This is the kind of spacing which our computational models would indicate are required. It is likely that experimenters have empirically learned what our computations predict. Gaps of 1 cm are insufficient, but gaps of a few cm are adequate.

There may be a very low density region at the front of the blowoff which has not been included in our calculations. Such a region would be collisionless.

The final topic is the stability of the blowoff region. The blowoff typically starts at high velocity and is stopped by the magnetic field. During this deceleration phase, the blowoff region will be Rayleigh-Taylor unstable in the same way that plasma liner implosions are unstable [10, 11]. However, calculations based on simple application of classical Rayleigh-Taylor formula show that the growth times are fairly long. For example, the number of e-folds is only 6 at an inverse wave number of 0.04 cm in the reference model. Thus, the instability is considerably less worrisome for the wall blowoff than for liner implosions.

REFERENCES

1. Reinovsky, R. E., D. L. Smith, W. L. Baker, J. H. Degnan, R. P. Henderson, R. J. Kohn, D. A. Kloc and N. F. Roderick, "Inductive Store Pulse Compression System for Driving High Speed Plasma Implosions," IEEE Trans. Plasma Sci., PS-10, 73, 1982.
2. Seiler, S., J. F. Davis, P. J. Turchi, G. Bird, C. Boyer, D. Conte, R. Crawford, H. DeRoad, G. Fisher, A. Latter, W. Tsai and T. Wilcox, "High Current Coaxial Plasma Gun Discharges Through Structural Foils, 4th IEEE Pulsed Power Conference, p. 346, 1983.
3. McCullough, W., private communication, 1984.
4. Shannon, J., J. Pearlman, A. Wilson and M. Friedman, "Diode Design Considerations for the SHIVA Pulsed Power System," Maxwell Laboratories, Inc., MLR-1040, January 1981.
5. Wilson, A., and M. C. Friedman, "Vacuum Transmission Line Technology," Systems, Science and Software, SSR-R-81-4780, December 1980.
6. Wilson, A., and M. C. Friedman, "Preliminary Diode Design" Systems, Science, and Software, SSR-R-81-4782, December 1980.
7. Glenn, D., A User's Guide for MACH1, AMRC-R-313, Mission Research Corporation, September 1981.
8. Buff, J., An MHD Capability for the Radiation Hydrodynamics Code MACH1, AMRC-R-357, Mission Research Corporation, April 1982.
9. Buff, J. S. and R. E. Reinovsky, "Wall Ablation Models for Plasma Flow Switches," AMRC-R-634, Mission Research Corporation, 1984.
10. Roderick, N. F., T. W. Hussey, R. J. Faehl and R. W. Boyd, Appl. Phys. Lett., 32, 273, 1978.
11. Hussey, T. W., N. F. Roderick and D. A. Kloc, J. Appl. Phys., 51, 1452, 1980.

TABLE 1. VACUUM FEED EXPERIMENTS

EXPERIMENT		MODEL (FIG. 5)	
FEED GAP	TIME Ip-CLOSE	EQUIV. TIME	BLOWOFF THICKNESS
1.26 cm	350 ns	6.35 μ s	0.7 cm
1.91 cm	900 ns	6.90 μ s	1.0 cm
2.80 cm	1.5 μ s	7.30 μ s	1.4 cm