

TA7
-W34
NO. 2-
358
EC

CORPS OF ENGINEERS, U. S. ARMY

UPSTREAM EMERGENCY DAM
CHEATHAM LOCK, CUMBERLAND RIVER, TENNESSEE

HYDRAULIC MODEL INVESTIGATION



TECHNICAL MEMORANDUM NO. 2-358

CONDUCTED FOR

NASHVILLE DISTRICT, CORPS OF ENGINEERS

BY

WATERWAYS EXPERIMENT STATION

VICKSBURG, MISSISSIPPI

ARMY-MRC VICKSBURG MISS

APRIL 1953

PROPERTY OF U. S. ARMY
OFFICE CHIEF OF ENGINEERS
LIBRARY

Report Documentation Page

Form Approved
OMB No. 0704-0188

Public reporting burden for the collection of information is estimated to average 1 hour per response, including the time for reviewing instructions, searching existing data sources, gathering and maintaining the data needed, and completing and reviewing the collection of information. Send comments regarding this burden estimate or any other aspect of this collection of information, including suggestions for reducing this burden, to Washington Headquarters Services, Directorate for Information Operations and Reports, 1215 Jefferson Davis Highway, Suite 1204, Arlington VA 22202-4302. Respondents should be aware that notwithstanding any other provision of law, no person shall be subject to a penalty for failing to comply with a collection of information if it does not display a currently valid OMB control number.

1. REPORT DATE APR 1953		2. REPORT TYPE		3. DATES COVERED 00-00-1953 to 00-00-1953	
4. TITLE AND SUBTITLE Upstream Emergency Dam, Cheatham Lock, Cumberland River, Tennessee: Hydraulic Model Investigation				5a. CONTRACT NUMBER	
				5b. GRANT NUMBER	
				5c. PROGRAM ELEMENT NUMBER	
6. AUTHOR(S)				5d. PROJECT NUMBER	
				5e. TASK NUMBER	
				5f. WORK UNIT NUMBER	
7. PERFORMING ORGANIZATION NAME(S) AND ADDRESS(ES) U.S. Army Corps of Engineers, Waterway Experiment Station, 3903 Halls Ferry Road, Vicksburg, MS, 39180				8. PERFORMING ORGANIZATION REPORT NUMBER	
9. SPONSORING/MONITORING AGENCY NAME(S) AND ADDRESS(ES)				10. SPONSOR/MONITOR'S ACRONYM(S)	
				11. SPONSOR/MONITOR'S REPORT NUMBER(S)	
12. DISTRIBUTION/AVAILABILITY STATEMENT Approved for public release; distribution unlimited					
13. SUPPLEMENTARY NOTES					
14. ABSTRACT					
15. SUBJECT TERMS					
16. SECURITY CLASSIFICATION OF:			17. LIMITATION OF ABSTRACT	18. NUMBER OF PAGES	19a. NAME OF RESPONSIBLE PERSON
a REPORT unclassified	b ABSTRACT unclassified	c THIS PAGE unclassified			

PREFACE

Model investigation of the upstream emergency dam for Cheatham Lock was conducted for the Nashville District, CE, by the Waterways Experiment Station during the period July 1949 to August 1950. Authority for the tests was granted by the Chief of Engineers in a teletype, dated 28 July 1949, to the Division Engineer, Ohio River Division.

Mr. J. H. Douma of the Office, Chief of Engineers; Colonel A. W. Pence, District Engineer; and Messrs. G. O. Prados, J. Mathewson, and R. H. Tuggle of the Nashville District visited the Waterways Experiment Station during the course of the study to discuss test results and to correlate these results with design work being carried on in the district office.

Personnel of the Waterways Experiment Station actively connected with the model study were Messrs. F. R. Brown, T. E. Murphy, T. J. Buntin, J. H. Ables, Jr., and H. H. Allen.

CONTENTS

	<u>Page</u>
PREFACE	i
SUMMARY	v
PART I: INTRODUCTION	1
Cheatham Lock and Dam	1
The Emergency Dam	2
The Problem	4
PART II: THE MODEL	5
Scale Relationships	5
Description	5
Appurtenances and Their Application	7
PART III: TESTS AND RESULTS	8
Test Procedure	8
Original Design Wicket	8
Curved Wicket	13
Curved Wicket of Revised Design	14
PART IV: CONCLUSIONS	18
TABLES 1-7	
PLATES 1-12	

SUMMARY

Tests conducted on a 1:12-scale model of wickets proposed for use as an emergency dam in the upstream lock approach at Cheatham Lock and Dam were concerned initially with the determination of the force required to raise the wickets under emergency conditions. The tests demonstrated, however, that the dynamic force of the water flowing over and around the wickets resulted in a more critical problem. As the wickets were raised, the uplift force acting upon the wickets slammed them into the closed position with considerable force. With the flat skin plate of the wicket of original design, an unduly long strut was necessary to overcome the uplift force of the flowing water. Use of a curved skin plate resulted in a more stable wicket with shorter strut arms. The maximum force required to raise the curved wicket with a 12-ft head differential was about one-and-one-half times the maximum force required to raise the wicket in still water.

UPSTREAM EMERGENCY DAM

CHEATHAM LOCK, CUMBERLAND RIVER, TENNESSEE

Hydraulic Model Investigation

PART I: INTRODUCTION

Cheatham Lock and Dam

1. Cheatham Lock and Dam, proposed for construction on the Cumberland River about 20 miles above Clarksville, Tennessee (fig. 1), is an important unit in the network of navigable waters of the Ohio and Mississippi River systems. This structure will provide a needed increase in depth at Nashville, the terminal point of most of the river traffic, and will eliminate the need for two outdated and troublesome existing locks and dams.

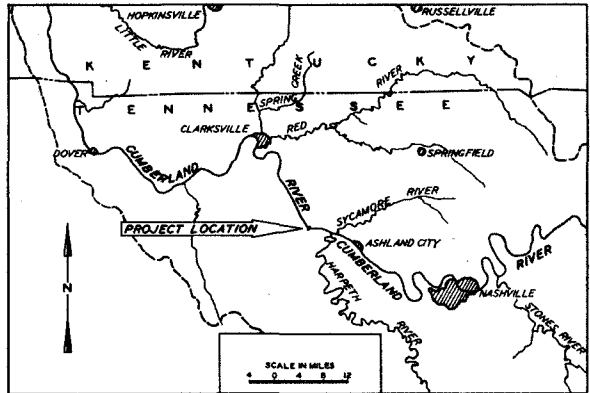

Fig. 1. Vicinity map

2. The dam will be of the nonnavigable gated type and will consist of a concrete sill at elevation 359* surmounted by seven tainter gates each 63.5 ft long by 27.5 ft high. Concrete piers 10 ft wide will take the gate thrust and support individual gate hoists and a structural steel service bridge. The lock will be set into the right bank floodplain with the riverward wall at about the natural bank line. Lock walls

* All elevations are in feet above mean sea level.

will be of concrete gravity section, founded on rock, and will have a freeboard of 10 ft above normal upper pool (elevation 382). The lock chamber will have a clear width of 110 ft and a length of 800 ft. Lock gates will be of the horizontally framed miter type, with hydraulic operating machinery. The filling and emptying system will be of the conventional longitudinal culvert and side chamber port type with reverse tainter valves.

The Emergency Dam

3. One problem that is always presented to designers of locks concerns the possible loss of the upstream pool by damage to the miter gates either through accident or sabotage. Engineers of the Nashville District office proposed the use of an emergency dam, to be located in the upstream lock approach, to forestall such a possibility. The emergency dam will also permit unwatering of the lock for routine inspection and necessary repairs. This emergency dam will consist of 15 wickets 22.60 ft high, 7.33 ft wide, and 1.03 ft thick. The wickets are designed to remain submerged during normal operation of the lock and to be raised into position in case of emergency or for unwatering. The wickets are to be pin-connected near the top to 27.75-ft-long strut arms which will in turn be fastened to the sill by means of a hinged connection. The bottoms of the wickets will slide in guides located against the upstream face of the sill. When in a lowered position, the strut arms will lie on the sill forming the floor of the lock approach and the wicket will be in a vertical position upstream from the sill as shown on plate 1. In the raised or closed position the face of the wicket will be on a 5-on-1 slope, the

same as the slope of the upstream face of the sill.

4. Each wicket will be raised individually by means of a chain hoist, sheaves, and a winch located on the lock wall (plate 2). Wicket No. 1, adjacent to the lock wall, will be raised by means of a chain passing over sheave 1 to the winch on the land wall. When wicket No. 1 is in the lowered position the landward hoist chain will fit into a recess in the lock wall. As the wicket is raised it also raises the hoist chain to wicket No. 2. When wicket No. 1 is raised and locked into position over the sill by means of the small clips located on the sides of the wickets, sheave 2 is moved to the riverward side of wicket No. 1, and the hoist chain from wicket No. 2 is passed over sheave 2 and sheave 1 to the winch. As wicket No. 2 is raised it also raises the hoist chain for wicket No. 3. Each succeeding wicket is raised in the manner described, sheave 2 being moved outward as succeeding wickets are raised.

5. In the original design, with all wickets in a raised position a 1-in. opening would exist between wickets. It was planned to seal this opening by means of a filler plate to be inserted after the wickets are raised. The force of water on the upper pool side would maintain the filler plate in place and prevent the passage of flow through the wickets.

6. It is contemplated that the wickets will be lowered only under balanced head conditions. The procedure described above for raising the wickets will be reversed to lower the wickets. The clips on the side of each wicket will be disengaged and each wicket, starting with the river-side, will be lowered into position on the upstream side of the sill. Sheave 2 will be moved landward as succeeding wickets are lowered. The dead weight will be the only force required to lower the wickets.

The Problem

7. No difficulty was expected in raising or lowering the wickets in still water (no flow through the lock) since the dead weight of the wickets was known and sliding friction could be estimated. However, the operation of the wickets under emergency conditions (flow through the locks) introduced complications in defining hoist requirements. A model study was considered necessary to evaluate the magnitude of the dynamic force of flow over and around the wickets and on the strut arms.

PART II: THE MODEL

Scale Relationships

8. In order that a model reproduce accurately the flow conditions of its prototype, similarity, both in a geometric sense and with respect to the predominant forces affecting motion, must exist between the two systems. In the case of the system under consideration, the force of gravity was predominant in its effect upon the inertia of fluid particles and of wicket movement. Accordingly, geometric and dynamic similarity between model and prototype was established by constructing all pertinent features of the test wickets to an undistorted linear scale ratio, and then treating all hydraulic quantities in their proper relationships as derived from the Froude law. General relationships existing were as follow:

<u>Dimension</u>	<u>Ratio</u>	<u>Scale Relationships</u>
Length	$L_r = L$	1:12
Time	$T_r = L_r^{1/2}$	1:3.464
Velocity	$V_r = L_r^{1/2}$	1:3.464
Weight	$W_r = L_r^3$	1:1728
Force	$F_r = L_r^3$	1:1728
Discharge	$Q_r = L_r^{5/2}$	1:498.8

Description

9. The model reproduced 5 of the 15 prototype wickets and the sill to which the wickets were attached (plate 3 and fig. 2). One model wicket was constructed of brass with aluminum struts and reproduced the

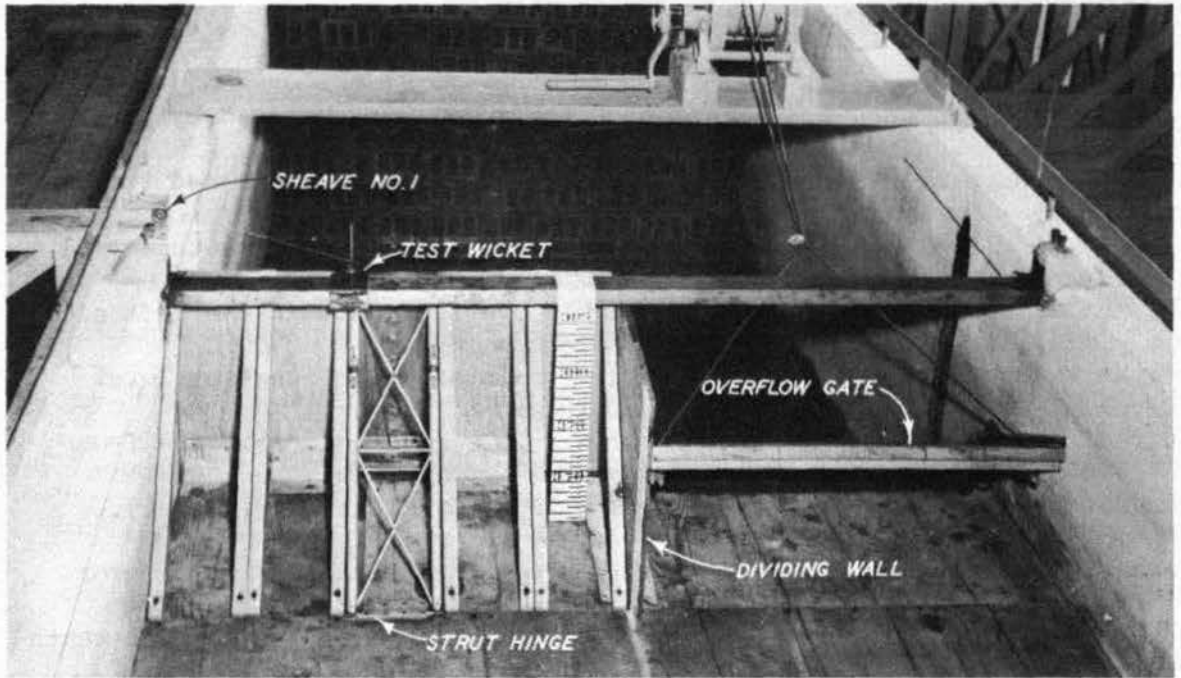

Fig. 2. Upstream view of model

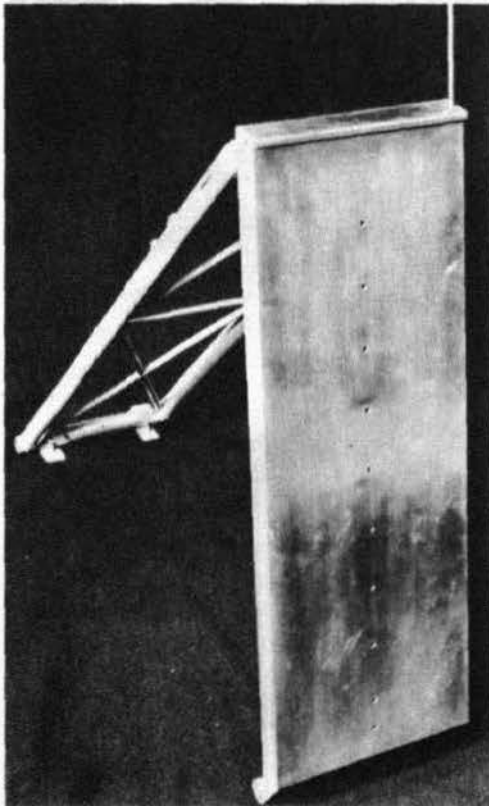

Fig. 3. Original design wicket

prototype wicket to scale in size, shape and weight (plate 1 and fig. 3). Small roller bearings were installed in the bottom of the model wicket to reduce friction between the wicket and the guide on the upstream face of the sill to a minimum. In the prototype the base of the wicket will slide in guides on the face of the sill. The test wicket was moved to different positions as necessitated by the testing program. The remaining four wickets were reproduced schematically, retaining only the proper shape and size.

Appurtances and Their Application

10. Water used in operation of the model was supplied by centrifugal pumps and after flowing through the model was returned to the sump by an underground conduit. Point gages were used to measure pool and tailwater elevations. An adjustable overflow gate in the left side of the model flume provided a means for maintaining a constant level in the headbay during a test operation. This gate was separated from the five wickets of the model by means of a dividing wall (fig. 2). Forces were measured on the test wicket by means of a force indicator (fig. 4) graduated in tenths of pounds and accurate to the nearest tenth of a pound.

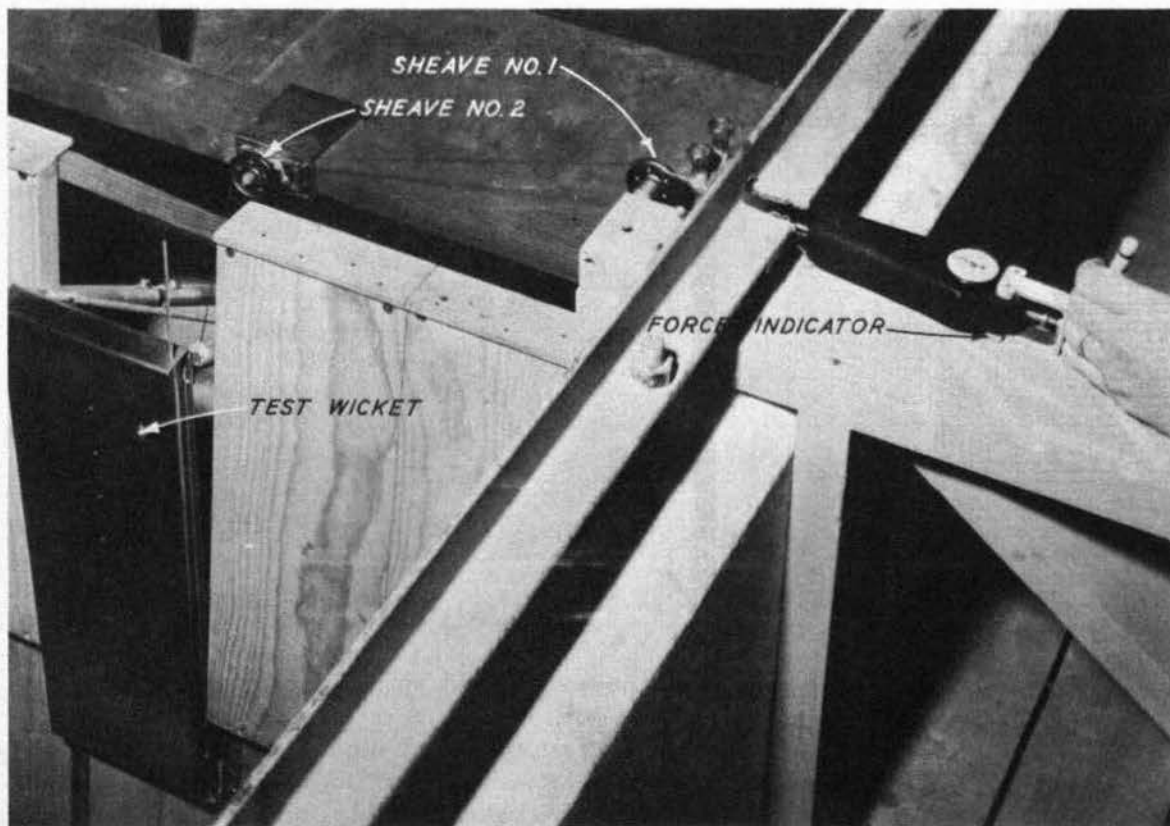

Fig. 4. View of force indicator

PART III: TESTS AND RESULTS

Test Procedure

11. Tests were conducted with the headwater or upstream pool maintained at a constant elevation of 385. Prior to the start of a test the hoisting apparatus was inspected to insure that all cables and sheaves were free of excessive friction; the moving parts of the wicket were checked and lubricated; and the water levels in the upper pool and below the wickets were properly adjusted. The force indicator, having been previously zeroed, was attached to the hoisting cable and the force required to operate the test wicket applied through the force indicator. For all measurements the wicket was operated manually at a constant rate of speed of about three prototype feet per minute. The force required to hold the wicket at a particular position was simulated by pulling the wicket to the desired position and holding it there for a measurement. Data were recorded for the most part with the test wicket in the center of the model, thus reproducing typical force conditions for an interior wicket. Wickets Nos. 1 and 2 were maintained in a raised position while wickets Nos. 4 and 5 were maintained in a lowered position; wicket No. 3 was the operating or test wicket. The test wicket was moved to simulate other positions after a satisfactory design of wicket had been developed.

Original Design Wicket

12. Prior to determination of the force required to raise and lower the wicket of original design, a series of tests was made to determine the point at which the chain hoist had to be attached to insure vertical movement of the wicket. The original vertical distance of 18.33 ft from the top

of wicket to the point of chain attachment was maintained and the lateral distance with respect to the vertical center line was varied. Only an average distance could be determined as the angle of the chain hoist passing over the sheave and the resulting twisting movement varied as the wicket was raised. Model performance indicated that the point of attachment of the chain hoist that would reduce the twisting movement of the gate to a minimum was 0.35 ft to the right of the vertical center line of the wicket.

13. Maximum force required to raise the wicket with no water against it was 9158 lb. A maximum force of 8985 lb was required to raise the test wicket with the upper and lower pools at elevation 385 (no flow through the model). The force required for the operation of the wicket of original design with flow through the lock chamber (fig. 5) is tabulated in

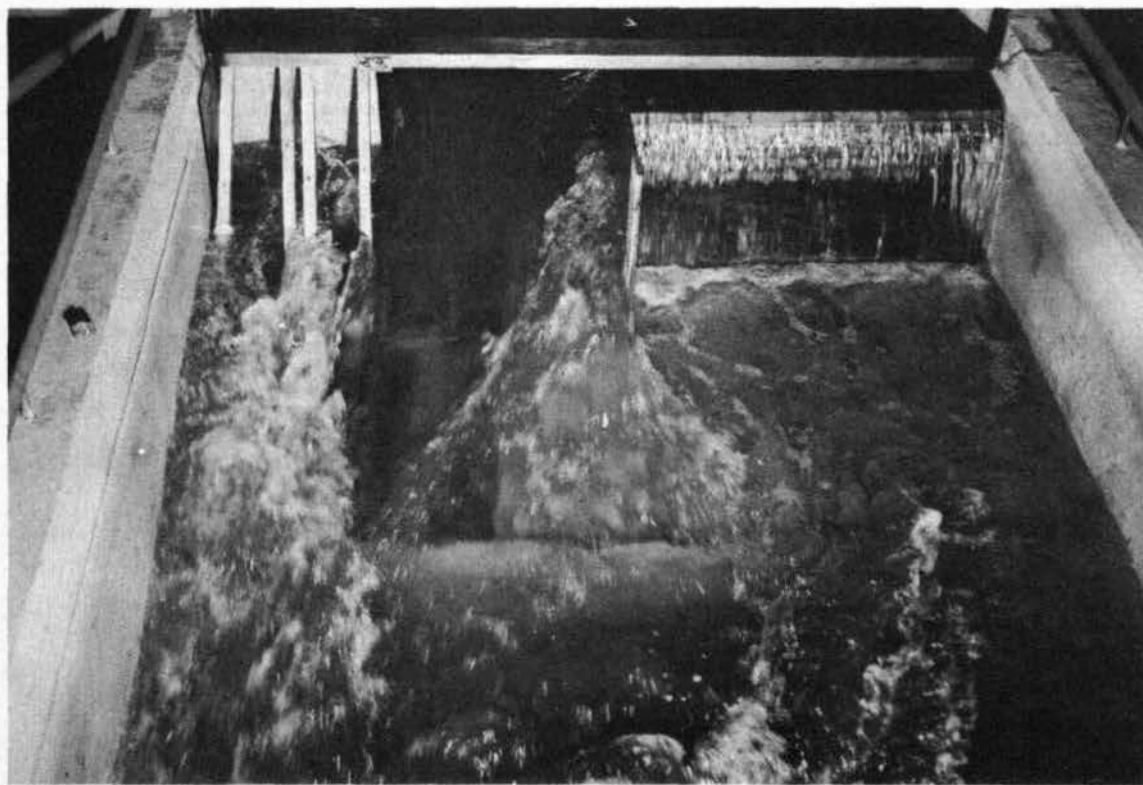

Fig. 5. Flow through emergency dam; wickets Nos. 1 and 2 raised, wickets Nos. 3, 4, and 5 lowered

table 1 and plotted on plate 4. The magnitude of the hydraulic force required to raise the wicket decreased as the wicket was raised. With a head differential of 12 ft, the hoist requirements varied from 7603 lb at the start of movement to 1728 lb with the wicket raised 6 ft. With the wicket raised 6.5 ft (one-third travel), the resultant of the dynamic forces balanced the static weight of the wicket; when the wicket was raised above this point the dynamic forces tending to rotate the gate about its strut hinge must have increased as the wicket was slammed into the fully raised position with considerable force. This condition was entirely unexpected and increased the complexity of the problem of operating the wickets of the emergency dam. In order to determine the magnitude of the dynamic force causing the wicket to slam into the raised position, a sheave was placed on the floor of the lock approach and the force required to hold the wicket stationary was measured for each wicket position. The force required to lower the wicket also is listed in table 1.

14. Comparative tests next were conducted to evaluate the effect of sliding versus rolling friction. As explained in paragraph 9, rollers were used at the base of the model wicket, although in the prototype the bottom of the wicket will slide along the face of the sill on a rounded contact. Results of these tests are shown in table 2 and plate 5. The data indicate that in general the friction force was less with the roller bearings installed on the bottom of the wicket and varied according to the position of the wicket. The maximum friction force variation was about 3500 lb and occurred with the wicket near the raised position.

15. An attempt was made to evaluate the actual magnitude of the

friction force as determined on the model. Plate 6 is a diagram of forces affecting motion of the wicket. It is to be noted that, during the lifting of a wicket, the friction force would add to the hoist requirements and would retard the uplift force tending to slam the wicket into the raised position. The friction force also would tend to decrease the resultant force required to hold the wicket at any position but would add to the resultant force required to lower the wicket. Careful analysis of the data in tables 1 and 2 reveals that for a 12-ft head differential, the friction force during the beginning of the lifting operation was about 1000 lb (difference between force required to raise wicket and force required to hold it in position). The data also indicate that the difference between the maximum resultant force required to hold the wicket in position and that required to lower it varied from 10,000 to 12,000 lb; since the friction force acts in opposite directions in this instance, the average value of the friction force was about 5000 to 6000 lb. The difference between the force required to hold the wicket in place and the force required to lower it is not entirely the result of friction. During the lowering procedure the wicket actually moves upstream slightly, requiring some displacement of the water, which adds to the downward force required to lower the wicket. The separation of the two forces, friction and displacement, is a complex procedure and has not been attempted. (A similar effort to evaluate friction forces with the curved-type wicket, discussed later in the text, was even more difficult as displacement of flow occurred as the wicket was raised as well as when it was lowered.) Therefore it can only be concluded that the maximum value of the friction force from model results would vary between 1000 and

6000 lb, depending upon the position of the wicket.

16. Evaluation of the coefficient of friction (static and kinetic) existing between the roller bearings and the metal guides was accomplished by loading the test wicket in the dry with weights equivalent to about the lateral thrust (87 lb, model) of the water expected when the wicket was near the raised position and recording the pull necessary to start and maintain movement. Tests also were made for other weights. The resulting coefficient plots are shown on plate 7. The coefficients of friction for metal on metal vary from 0.15 to 0.20, which are somewhat in excess of the values obtained. Therefore the actual friction force in the prototype should be in excess of the values obtained in the model scaled to their prototype equivalents.

17. Efforts were directed toward the elimination or reduction of the uplift force by revisions to the length of the strut arm supporting the wicket. An increase in the length of the strut arm should increase the moment of the forces resisting the pull of the hoist chain which in turn should offset the moment of the dynamic forces tending to slam the wicket into the raised position. The length of the strut arm was varied from 24.75 to 45 ft; the original length of the strut was 27.75 ft. For this series of tests the location of the hinged connection of the strut arm on the sill was varied to maintain the top of the wicket in the raised position at its original location. The desired effect was obtained in that, as the strut arm was lengthened, the force tending to slam the wicket into the raised position decreased. With a strut length of 40.25 ft an uplift force existed only in a narrow range of wicket travel. A strut length of 45.0 ft resulted in an elimination of all uplift force. Detailed

information is presented in table 3 and on plate 8.

Curved Wicket

18. Since the wicket of original design required an extra long strut to prevent the dynamic force of flow from slamming the wicket into the raised position, an alternate wicket design with a curved upstream face was proposed. The curved wicket would provide an additional downward component of flow which it was thought would offset the dynamic uplift force (plate 6b). The original strut arm length of 27.75 ft was retained; the upstream face of the sill was vertical. Details of the wicket are shown on plate 9, while figs. 6 and 7 are views of the curved wicket in profile and in the model. Dry weight of the wicket and strut was 12,864 lb. The hoist chain was attached to the top of the wicket at a point approximately 1.0 ft from the right (near) edge of the wicket.

19. Forces required to

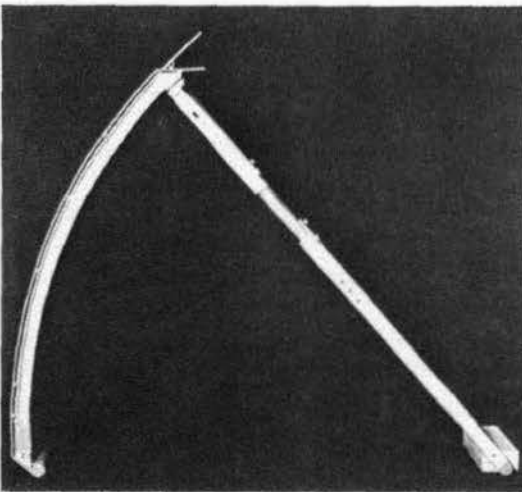

Fig. 6. Curved wicket in profile

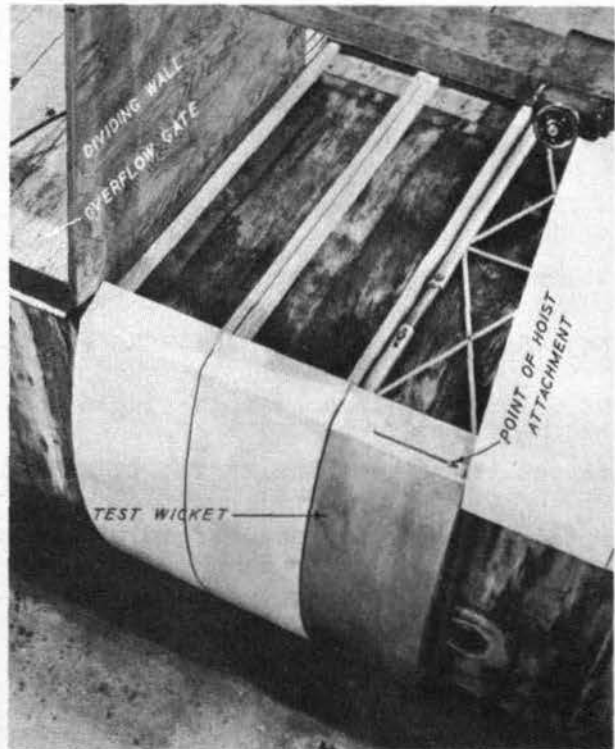

Fig. 7. Curved wicket in model

raise the curved-type wicket are presented in table 4. With no water in the model the force required to raise the wicket varied from a maximum of 11,923 lb at the beginning of travel to a minimum of 9331 lb when the wicket was 2.5 ft from the raised position. With the water at elevation 385.0 in both the upper and lower pools (no flow) the force required to raise the wicket varied from a maximum of 10,022 lb to a minimum of 7430 lb with the maximum and minimum forces occurring at the same wicket positions as with the dry model. With flow through the model, the force required to raise the wicket was greatest with the largest head differential. With a 12-ft head differential a maximum force of 12,960 lb was required to start movement as opposed to a minimum force of 1210 lb obtained during the final phase of the raising process (plate 10). Thus the use of the curved-type wicket accomplished the desired effect of eliminating the uplift force slamming the wicket into the raised position.

Curved Wicket of Revised Design

20. Since the basic design of the curved wicket had resulted in satisfactory performance, refinements were made to include provisions for sealing. As mentioned in paragraph 5, it was planned to seal the wickets of original design by inserting a filler plate after the wickets had been raised. However, the curved wicket face necessitated another procedure. Details of the revised curved wicket showing the method of sealing are presented on plate 11 and a view of the wicket with sealing edge is shown in fig. 8. Provisions for sealing of the curved wicket required a flat recess cut into the outer 2 in. of each wicket; the depth of the recess varied because of the curvature of the wicket. A 1-in. clear distance

between wickets was still maintained. Thus, the over-all width of the recess between wickets was 5 in. into which a 3-in.-diameter pipe will be inserted to provide the seal. The force of water on the upstream side of the wickets will maintain the seal pipe in position. Dry weight of the revised curved wicket and strut was 13,254 lb.

21. With the water at elevation 385.0 in both the upper and lower pools (no flow) a maximum force of 9,504 lb was required to raise the wicket. Forces required to operate the revised curved wicket are listed in table 5 and plotted on plate 12. With a 12-ft head differential, the force measured while the wicket was being raised varied from a maximum of 13,306 lb with the top of the wicket at elevation 370.75 (19 per cent travel) to a minimum of 5184 lb with the top of the wicket between elevations 379.5 and 382 (about 70 per cent travel). At no point during the operating cycle did the resultant force tend to slam the wicket into the raised position. However, when the top of the wicket was at or above elevation 375.75 (about 44 per cent travel) movement of the wicket could be stopped, the lifting cable slacked, and the wicket would remain stationary. Forces required to lower the wicket at a rate of 3 ft per min through the range in which it would remain stationary varied up to a maximum force of 18,144 lb with the top of the wicket at elevation 387.0

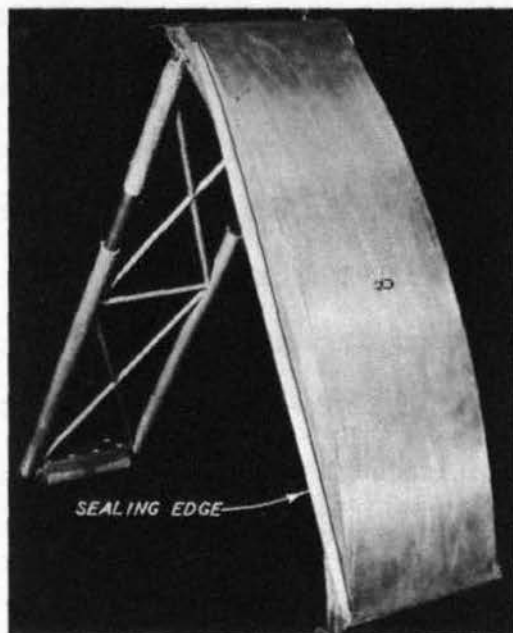

Fig. 8. Revised curved wicket with side sealing surface installed

(full travel). Comparison of the above data with those presented in table 4 for the initial curved-type wicket indicates fair agreement. Discrepancies can be attributed in part to the greater weight of the revised wicket. Although a maximum force of 18,144 lb was required to lower the test wicket once it was raised, this force is only about 50 per cent of that required to lower the flat wicket of original design.

22. The forces required to operate the test wicket located against the landwall with all other wickets lowered are given in table 6. Thus, conditions were representative of the force required to raise wicket No. 1. A few tests also were conducted with all wickets raised and the test wicket in the No. 1 position (table 7); this simulated the force required to raise the last wicket (No. 15) in the emergency dam. The data with the wicket in the end positions were procured to provide full information on the wicket proposed for construction in the prototype. It was found that the force required to operate wicket No. 1 was less than that required to operate the interior wickets. The force required to operate the last wicket (No. 15) was slightly higher than that required to operate an interior wicket. For a 12-ft head differential the maximum forces required to raise the test wicket were 8640 lb for the first wicket, 13,306 lb for the interior wickets, and 14,342 lb for the last wicket. However, all forces were considered acceptable by the designers of the emergency dam.

23. Since tests had demonstrated that, with a head differential, a downward force would be required to lower a wicket from the raised position, the Nashville District requested that a test be made to determine the force required to lower one wicket with the pool at elevation 385.0 and the lock chamber dry. Normally, the force required to lower the

wickets is not important since the wickets will be lowered under balanced head conditions, i.e., with the same water level on each side of the emergency dam. It was felt, however, that under certain conditions filling the pumped-out lock chamber by lowering one of the wickets may be desirable. The force required to lower wicket No. 3 with wickets Nos. 1, 2, 4, and 5 raised, the upper pool at elevation 385.0, and the lower pool dry, is tabulated below.

<u>Elevation Top of Wicket</u>	<u>Force Required to Lower Wicket (Lb)</u>
387.0	32,832
384.5	29,192
382.0	20,136
379.5	17,280
377.0	10,368
374.5	5,184

If the curved wickets are operated at unbalanced head conditions, some additional force, other than the dead weight (paragraph 6), will have to be applied to lower the wickets.

PART IV: CONCLUSIONS

24. The model investigation demonstrated the feasibility of using wickets as an emergency dam in the lock approach.

25. Initial tests conducted on a wicket having a flat skin plate revealed that hydraulic forces tended to rotate the wicket to the raised position. In the upper portion of the operating cycle these forces caused the wicket to slam into the raised position with such violence that it might possibly be damaged.

26. With a curved skin plate on the wicket, hydraulic forces opposed the raising of the wicket in the lower portion of the operating cycle and assisted in raising the wicket in the upper portion of the operating cycle. However, the maximum hydraulic force opposing upward movement of the wicket amounted to only about 50 per cent of the weight and at no point did the uplift force exceed the weight of the wicket. Lowering of the wickets under a head differential was not possible with the method proposed.

27. The use of flat recesses 2 in. wide along the sides of the wicket to provide sealing surfaces did not materially change the hydraulic force acting on the wicket.

TABLES

Table 1

OPERATION FORCE -- ORIGINAL DESIGN WICKET IN NO. 3 POSITION

<u>Pool Elev</u>		<u>Head Differential</u>	<u>Elevation Top</u>	<u>Force Required to</u>	<u>Force Required to Hold</u>	<u>Force Required to</u>
<u>Upper</u>	<u>Lower</u>	<u>Ft</u>	<u>of Wicket</u>	<u>Raise Wicket, Lb</u>	<u>Wicket in Position, Lb</u>	<u>Lower Wicket, Lb</u>
385.0	383.0	2.0	367.0	8,122	7,258	0
385.0	383.0	2.0	369.5	7,776	6,048	0
385.0	383.0	2.0	372.0	6,912	5,702	0
385.0	383.0	2.0	374.5	6,048	5,184	0
385.0	383.0	2.0	377.0	4,320	2,592	0
385.0	383.0	2.0	379.5	3,110	1,728	0
385.0	383.0	2.0	380.5	1,728	0	0
385.0	383.0	2.0	381.5	0	0	0
385.0	383.0	2.0	382.0	0	-2,592	-864
385.0	383.0	2.0	384.5	0	-5,184	-2,592
385.0	383.0	2.0	387.0	0	-6,912	-3,456
385.0	378.0	7.0	367.0	8,122	6,912	0
385.0	378.0	7.0	369.5	7,085	6,221	0
385.0	378.0	7.0	372.0	5,184	3,456	0
385.0	378.0	7.0	374.5	3,110	2,074	0
385.0	378.0	7.0	375.0	0	0	0
385.0	378.0	7.0	377.0	0	-3,456	-7,776
385.0	378.0	7.0	379.5	0	-8,640	-17,280
385.0	378.0	7.0	382.0	0	-17,280	-22,464
385.0	378.0	7.0	384.5	0	-19,008	-24,192
385.0	378.0	7.0	387.0	0	-20,736	-25,920
385.0	373.0	12.0	367.0	7,603	6,566	0
385.0	373.0	12.0	369.5	6,394	5,702	0
385.0	373.0	12.0	372.0	4,838	3,802	0
385.0	373.0	12.0	373.0	1,728	691	0
385.0	373.0	12.0	373.5	0	0	0
385.0	373.0	12.0	374.5	0	0	-3,456
385.0	373.0	12.0	377.0	0	-5,184	-13,824
385.0	373.0	12.0	379.5	0	-12,960	-20,736
385.0	373.0	12.0	382.0	0	-17,280	-27,648
385.0	373.0	12.0	384.5	0	-20,736	-31,104
385.0	373.0	12.0	387.0	0	-22,464	-34,560

Notes: Wickets Nos. 1 and 2 raised; wickets Nos. 4 and 5 lowered.

Positive force indicates tension in the hoist chain; negative force indicates an opposite force required to hold the wicket in position or to lower it.

Table 2

COMPARISON OF SLIDING FORCE AND ROLLING FORCE -- WICKET NO. 3

<u>Pool Elev</u>	<u>Head Differ-</u>	<u>Elevation Top</u>	<u>Force Required to</u>	<u>Force Required to Hold</u>	<u>Force Required to</u>	
<u>Upper</u>	<u>ential, Ft</u>	<u>of Wicket</u>	<u>Raise Wicket, Lb</u>	<u>Wicket in Position, Lb</u>	<u>Lower Wicket, Lb</u>	
<u>Lower</u>						
<u>Bottom of Wicket Sliding Along Face of Sill</u>						
385.0	373.0	12.0	367.0	7,603	6,566	0
385.0	373.0	12.0	369.5	6,394	5,702	0
385.0	373.0	12.0	372.0	4,838	3,802	0
385.0	373.0	12.0	373.0	1,728	691	0
385.0	373.0	12.0	373.5	0	0	0
385.0	373.0	12.0	374.5	0	0	- 3,456
385.0	373.0	12.0	377.0	0	- 5,184	-13,824
385.0	373.0	12.0	379.5	0	-12,960	-20,736
385.0	373.0	12.0	382.0	0	-17,280	-27,648
385.0	373.0	12.0	384.5	0	-20,736	-31,104
385.0	373.0	12.0	387.0	0	-22,464	-34,560
<u>Bottom of Wicket Rolling Along Face of Sill</u>						
385.0	373.0	12.0	367.0	7,258	6,566	0
385.0	373.0	12.0	369.5	6,566	5,530	0
385.0	373.0	12.0	372.0	5,184	4,493	0
385.0	373.0	12.0	374.5	1,728	691	0
385.0	373.0	12.0	375.0	0	0	0
385.0	373.0	12.0	375.5	0	- 3,456	- 6,912
385.0	373.0	12.0	377.0	0	- 6,912	-13,824
385.0	373.0	12.0	379.5	0	-10,369	-20,736
385.0	373.0	12.0	382.0	0	-15,552	-31,104
385.0	373.0	12.0	384.5	0	-17,280	-34,560
385.0	373.0	12.0	387.0	0	-19,008	-36,288

Notes: Wickets Nos. 1 and 2 raised; wickets Nos. 4 and 5 lowered.

Positive force indicates tension in the hoist chain; negative force indicates an opposite force required to hold the wicket in position or to lower it.

Table 3

EFFECT OF STRUT LENGTH ON OPERATING FORCE -- WICKET NO. 3

<u>Pool Elev</u>		<u>Head</u>	<u>Elev</u>	<u>Force Re-</u>	<u>Force Required</u>	<u>Force Re-</u>
<u>Upper</u>	<u>Lower</u>	<u>Differ-</u>	<u>Top of</u>	<u>quired to</u>	<u>to Hold Wicket</u>	<u>quired to</u>
		<u>Ft</u>	<u>Wicket</u>	<u>Raise</u>	<u>in Position</u>	<u>Lower</u>
				<u>Wicket, Lb</u>	<u>Lb</u>	<u>Wicket, Lb</u>
<u>Strut Length 24.75 Ft</u>						
385.0	373.5	11.5	367.0	7,603	6,912	0
385.0	373.5	11.5	369.5	8,294	6,912	0
385.0	373.5	11.5	372.0	5,184	4,320	0
385.0	373.5	11.5	373.5	3,110	864	0
385.0	373.5	11.5	374.5	864	0	0
385.0	373.5	11.5	374.7	0	0	0
385.0	373.5	11.5	375.0	0	0	0
385.0	373.5	11.5	375.5	0	-3,456	-12,096
385.0	373.5	11.5	377.0	0	-7,776	-17,280
385.0	373.5	11.5	379.5	0	-12,096	-22,464
385.0	373.5	11.5	382.0	0	-18,144	-27,648
385.0	373.5	11.5	384.5	0	-19,008	-31,104
385.0	373.5	11.5	387.0	0	-19,872	-33,696
<u>Strut Length 26.75 Ft</u>						
385.0	373.5	11.5	367.0	5,357	4,320	0
385.0	373.5	11.5	369.5	4,493	3,456	0
385.0	373.5	11.5	370.5	3,456	2,592	0
385.0	373.5	11.5	371.0	2,246	1,210	0
385.0	373.5	11.5	371.5	1,728	518	0
385.0	373.5	11.5	371.75	0	0	0
385.0	373.5	11.5	372.0	0	0	0
385.0	373.5	11.5	373.0	0	-3,456	-6,912
385.0	373.5	11.5	374.5	0	-6,048	-11,232
385.0	373.5	11.5	377.0	0	-10,368	-18,144
385.0	373.5	11.5	379.5	0	-17,280	-25,920
385.0	373.5	11.5	382.0	0	-18,144	-32,832
385.0	373.5	11.5	384.5	0	-19,008	-33,696
385.0	373.5	11.5	387.0	0	-19,008	-34,560
<u>Strut Length 31.75</u>						
385.0	374.0	11.0	367.0	8,294	6,221	0
385.0	374.0	11.0	369.5	5,357	3,974	0
385.0	374.0	11.0	372.0	3,456	2,246	0
385.0	374.0	11.0	373.0	2,074	1,039	0
385.0	374.0	11.0	373.5	0	0	0
385.0	374.0	11.0	374.0	0	-1,728	-12,096
385.0	374.0	11.0	377.0	0	-8,640	-20,736
385.0	374.0	11.0	379.5	0	-12,096	-25,920

(Continued)

Table 3 (Continued)

<u>Pool</u>	<u>Elev</u>	<u>Head</u>	<u>Elev</u>	<u>Force Re-</u>	<u>Force Required</u>	<u>Force Re-</u>
<u>Upper</u>	<u>Lower</u>	<u>Differ-</u>	<u>Top of</u>	<u>quired to</u>	<u>to Hold Wicket</u>	<u>quired to</u>
		<u>ential</u>	<u>Wicket</u>	<u>Raise</u>	<u>in Position</u>	<u>Lower</u>
		<u>Ft</u>		<u>Wicket, Lb</u>	<u>Lb</u>	<u>Wicket, Lb</u>
<u>Strut Length 31.75 (Cont'd)</u>						
385.0	374.0	11.0	382.0	0	-15,552	-27,648
385.0	374.0	11.0	384.5	0	-17,280	-29,376
385.0	374.0	11.0	387.0	0	-18,144	-31,104
<u>Strut Length 38.0 Ft</u>						
385.0	373.0	12.0	367.0	8,640	7,603	0
385.0	373.0	12.0	369.5	9,158	7,085	0
385.0	373.0	12.0	372.0	6,912	6,221	0
385.0	373.0	12.0	374.5	5,530	3,629	0
385.0	373.0	12.0	377.0	3,456	1,728	0
385.0	373.0	12.0	377.5	1,728	0	0
385.0	373.0	12.0	378.0	0	0	0
385.0	373.0	12.0	379.0	0	-3,456	-15,552
385.0	373.0	12.0	379.5	0	-5,184	-19,008
385.0	373.0	12.0	382.0	0	-6,912	-22,464
385.0	373.0	12.0	384.5	0	-8,640	-24,192
385.0	373.0	12.0	387.0	0	-10,368	-26,784
<u>Strut Length 40.25 Ft</u>						
385.0	373.0	12.0	367.0	7,258	3,802	0
385.0	373.0	12.0	369.5	8,294	4,493	0
385.0	373.0	12.0	372.0	7,430	3,283	0
385.0	373.0	12.0	374.5	7,258	2,765	0
385.0	373.0	12.0	377.0	6,048	2,074	0
385.0	373.0	12.0	379.5	2,592	1,382	0
385.0	373.0	12.0	380.0	0	0	0
385.0	373.0	12.0	381.0	0	-6,912	-21,600
385.0	373.0	12.0	382.0	0	-7,776	-24,192
385.0	373.0	12.0	384.5	-3,110	-2,074	0
385.0	373.0	12.0	387.0	-4,838	-1,382	0
<u>Strut Length 42.0 Ft</u>						
385.0	373.0	12.0	367.0	8,986	5,357	0
385.0	373.0	12.0	369.5	8,813	5,702	0
385.0	373.0	12.0	372.0	8,640	3,629	0
385.0	373.0	12.0	373.0	7,776	3,110	0
385.0	373.0	12.0	374.5	7,258	2,765	0
385.0	373.0	12.0	377.0	6,048	2,246	0
385.0	373.0	12.0	378.0	4,320	1,382	0

(Continued)

Table 3 (Continued)

<u>Pool</u>	<u>Elev</u>	<u>Head</u>	<u>Elev</u>	<u>Force Re-</u>	<u>Force Required</u>	<u>Force Re-</u>
<u>Upper</u>	<u>Lower</u>	<u>Differ-</u>	<u>Top of</u>	<u>quired to</u>	<u>to Hold Wicket</u>	<u>quired to</u>
		<u>ential</u>	<u>Wicket</u>	<u>Raise</u>	<u>in Position</u>	<u>Lower</u>
		<u>Ft</u>		<u>Wicket, Lb</u>	<u>Lb</u>	<u>Wicket, Lb</u>
<u>Strut Length 42.0 Ft (Cont'd)</u>						
385.0	373.0	12.0	379.5	3,110	864	0
385.0	373.0	12.0	380.0	0	0	0
385.0	373.0	12.0	381.0	0	-4,320	-18,144
385.0	373.0	12.0	382.0	-3,802	-1,382	0
385.0	373.0	12.0	384.2	-3,110	-2,074	0
385.0	373.0	12.0	387.0	-4,320	-2,938	0
<u>Strut Length 44.0 Ft</u>						
385.0	373.0	12.0	367.0	8,986	5,530	0
385.0	373.0	12.0	369.5	9,676	5,530	0
385.0	373.0	12.0	372.0	9,158	4,147	0
385.0	373.0	12.0	374.5	7,258	3,974	0
385.0	373.0	12.0	377.0	6,048	3,629	0
385.0	373.0	12.0	379.5	3,458	1,210	0
385.0	373.0	12.0	380.5	1,728	0	0
385.0	373.0	12.0	381.0	0	0	0
385.0	373.0	12.0	381.5	0	-5,184	-15,552
385.0	373.0	12.0	382.0	-5,357	-2,419	0
385.0	373.0	12.0	384.5	-7,776	-4,320	0
385.0	373.0	12.0	387.0	-9,158	-4,838	0
<u>Strut Length 45.0 Ft</u>						
385.0	373.0	12.0	367.0	8,986	5,530	0
385.0	373.0	12.0	369.5	10,022	6,394	0
385.0	373.0	12.0	372.0	10,368	6,566	0
385.0	373.0	12.0	374.5	8,294	4,838	0
385.0	373.0	12.0	377.0	7,776	4,320	0
385.0	373.0	12.0	379.5	4,320	3,802	0
385.0	373.0	12.0	382.0	3,110	1,901	0
385.0	373.0	12.0	384.5	2,765	1,555	0
385.0	373.0	12.0	387.0	2,246	864	0

Notes: Wickets Nos. 1 and 2 raised; wickets Nos. 4 and 5 lowered.
 Positive force indicates tension in the hoist chain; negative force indicates an opposite force required to hold the wicket in position or to lower it.

Table 4

OPERATING FORCE -- CURVED-TYPE WICKET IN NO. 3 POSITION

Pool Elev		Head Differential	Elev Top of Wicket	Force Required to Raise Wicket	Force Required to Hold Wicket in Position
Upper	Lower	Ft		Lb	Lb
0.0	0.0	0.0	367.0	11,923	10,714
0.0	0.0	0.0	369.5	11,405	11,059
0.0	0.0	0.0	372.0	11,059	10,541
0.0	0.0	0.0	374.5	11,509	10,368
0.0	0.0	0.0	377.0	10,451	10,022
0.0	0.0	0.0	379.5	10,195	9,504
0.0	0.0	0.0	382.0	10,022	8,813
0.0	0.0	0.0	384.5	9,331	8,640
0.0	0.0	0.0	387.0	10,368	7,776
385.0	385.0	0.0	367.0	10,022	9,504
385.0	385.0	0.0	369.5	9,331	8,986
385.0	385.0	0.0	372.0	8,813	8,640
385.0	385.0	0.0	374.5	8,467	8,122
385.0	385.0	0.0	377.0	8,122	7,776
385.0	385.0	0.0	379.5	7,776	7,430
385.0	385.0	0.0	382.0	7,603	7,085
385.0	385.0	0.0	384.5	7,430	6,912
385.0	385.0	0.0	387.0	7,949	7,258
385.0	384.0	1.0	367.0	9,850	9,331
385.0	384.0	1.0	369.5	9,504	8,640
385.0	384.0	1.0	372.0	8,986	8,294
385.0	384.0	1.0	374.5	8,467	7,776
385.0	384.0	1.0	377.0	7,949	7,258
385.0	384.0	1.0	379.5	7,776	5,184
385.0	384.0	1.0	382.0	7,603	3,456
385.0	384.0	1.0	384.5	7,776	2,074
385.0	384.0	1.0	387.0	8,640	4,838
385.0	378.0	7.0	367.0	10,451	9,677
385.0	378.0	7.0	369.5	10,022	9,158
385.0	378.0	7.0	372.0	9,677	9,158
385.0	378.0	7.0	374.5	8,294	7,603
385.0	378.0	7.0	377.0	7,603	5,184
385.0	378.0	7.0	379.5	6,048	3,456
385.0	378.0	7.0	382.0	3,456	2,074
385.0	378.0	7.0	384.5	3,456	356
385.0	378.0	7.0	387.0	5,184	0

(Continued)

Table 4 (Continued)

<u>Pool Elev</u>		<u>Head</u>	<u>Elev</u>	<u>Force Required</u>	<u>Force Required</u>
<u>Upper</u>	<u>Lower</u>	<u>Differ-</u>	<u>Top of</u>	<u>to Raise</u>	<u>to Hold Wicket</u>
		<u>ential</u>	<u>Wicket</u>	<u>Wicket</u>	<u>in Position</u>
		<u>Ft</u>		<u>Lb</u>	<u>Lb</u>
385.0	373.0	12.0	367.0	12,960	10,541
385.0	373.0	12.0	369.5	12,269	10,022
385.0	373.0	12.0	372.0	11,923	8,813
385.0	373.0	12.0	374.5	10,541	7,776
385.0	373.0	12.0	377.0	8,986	5,184
385.0	373.0	12.0	379.5	6,221	3,802
385.0	373.0	12.0	380.75	3,456	1,728
385.0	373.0	12.0	382.0	1,728	172
385.0	373.0	12.0	384.5	1,210	172
385.0	373.0	12.0	387.0	1,728	0

Notes: Wickets Nos. 1 and 2 raised; wickets Nos. 4 and 5 lowered.
No data recorded on the force required to lower wicket.

Table 5

OPERATING FORCE -- REVISED CURVED-TYPE WICKET IN NO. 3 POSITION

<u>Pool Elev</u>		<u>Head Differential</u>	<u>Elevation Top</u>	<u>Force Required to</u>	<u>Force Required to Hold</u>	<u>Force Required to</u>
<u>Upper</u>	<u>Lower</u>	<u>Ft</u>	<u>of Wicket</u>	<u>Raise Wicket, Lb</u>	<u>Wicket in Position, Lb</u>	<u>Lower Wicket, Lb</u>
385.0	385.0	0.0	367.0	9,504	9,158	0
385.0	385.0	0.0	369.5	9,331	8,813	0
385.0	385.0	0.0	372.0	9,158	8,640	0
385.0	385.0	0.0	374.5	8,640	8,122	0
385.0	385.0	0.0	377.0	8,467	8,294	0
385.0	385.0	0.0	379.5	7,040	7,776	0
385.0	385.0	0.0	382.0	7,949	7,430	0
385.0	385.0	0.0	384.5	8,122	7,084	0
385.0	385.0	0.0	387.0	8,640	7,776	0
385.0	384.0	1.0	367.0	10,022	8,122	0
385.0	384.0	1.0	369.5	9,850	8,294	0
385.0	384.0	1.0	372.0	9,331	7,949	0
385.0	384.0	1.0	374.5	8,986	6,912	0
385.0	384.0	1.0	377.0	8,467	6,048	0
385.0	384.0	1.0	379.5	7,776	4,320	0
385.0	384.0	1.0	382.0	7,258	3,110	0
385.0	384.0	1.0	384.5	7,258	1,210	0
385.0	384.0	1.0	387.0	7,949	864	0
385.0	378.0	7.0	367.0	10,195	6,566	0
385.0	378.0	7.0	369.5	12,442	6,912	0
385.0	378.0	7.0	372.0	11,405	4,838	0
385.0	378.0	7.0	373.25	10,886	2,592	0
385.0	378.0	7.0	374.5	9,504	864	0
385.0	378.0	7.0	375.75	8,986	0	- 2,930
385.0	378.0	7.0	377.0	8,640	0	- 5,011
385.0	378.0	7.0	379.5	6,912	0	- 7,949
385.0	378.0	7.0	382.0	4,320	0	-11,059
385.0	378.0	7.0	384.5	5,875	0	-14,515
385.0	378.0	7.0	387.0	6,394	0	-15,206

(Continued)

Table 5 (Continued)

<u>Pool Elev</u>		<u>Head Differential</u>	<u>Elevation Top</u>	<u>Force Required to</u>	<u>Force Required to Hold</u>	<u>Force Required to</u>
<u>Upper</u>	<u>Lower</u>	<u>Ft</u>	<u>of Wicket</u>	<u>Raise Wicket, Lb</u>	<u>Wicket in Position, Lb</u>	<u>Lower Wicket, Lb</u>
385.0	373.0	12.0	367.0	11,405	7,430	0
385.0	373.0	12.0	369.5	13,133	7,776	0
385.0	373.0	12.0	370.75	13,306	6,566	0
385.0	373.0	12.0	372.0	12,960	4,838	0
385.0	373.0	12.0	373.25	12,096	2,592	0
385.0	373.0	12.0	374.5	10,714	518	0
385.0	373.0	12.0	375.75	9,677	0	- 4,838
385.0	373.0	12.0	377.0	8,986	0	- 5,875
385.0	373.0	12.0	379.5	5,184	0	-12,442
385.0	373.0	12.0	382.0	5,184	0	-16,589
385.0	373.0	12.0	384.5	6,048	0	-17,280
385.0	373.0	12.0	387.0	6,912	0	-18,144

Notes: Wickets Nos. 1 and 2 raised; wickets Nos. 4 and 5 lowered.

Positive force indicates tension in the hoist chain; negative force indicates an opposite force required to hold the wicket in position or to lower it.

Table 6

OPERATING FORCE -- REVISED CURVED-TYPE WICKET IN NO. 1 POSITION

Pool Elev		Head Differential Ft	Elevation Top of Wicket	Force Required to Raise Wicket, Lb	Force Required to Hold Wicket in Position, Lb	Force Required to Lower Wicket, Lb
Upper	Lower					
385.0	384.0	1.0	367.0	7,949	7,085	0
385.0	384.0	1.0	369.5	8,122	6,739	0
385.0	384.0	1.0	372.0	8,294	6,394	0
385.0	384.0	1.0	374.5	7,776	5,875	0
385.0	384.0	1.0	377.0	7,258	5,530	0
385.0	384.0	1.0	379.5	6,912	4,838	0
385.0	384.0	1.0	382.0	7,258	3,802	0
385.0	384.0	1.0	384.5	7,776	4,320	0
385.0	384.0	1.0	387.0	8,122	4,838	0
385.0	378.0	7.0	367.0	5,357	1,728	0
385.0	378.0	7.0	369.5	6,048	2,074	0
385.0	378.0	7.0	370.75	5,702	1,382	0
385.0	378.0	7.0	372.0	5,530	346	0
385.0	378.0	7.0	373.25	5,184	0	-1,555
385.0	378.0	7.0	374.5	4,838	0	-2,246
385.0	378.0	7.0	377.0	4,493	0	-5,011
385.0	378.0	7.0	379.5	4,320	0	-7,258
385.0	378.0	7.0	382.0	4,147	0	-7,949
385.0	378.0	7.0	384.5	3,974	0	-11,059
385.0	378.0	7.0	387.0	3,802	0	-12,960
385.0	373.0	12.0	367.0	7,258	4,838	0
385.0	373.0	12.0	369.5	8,640	2,246	0
385.0	373.0	12.0	372.0	7,776	864	0
385.0	373.0	12.0	373.25	7,430	0	-1,210
385.0	373.0	12.0	374.5	6,912	0	-2,764
385.0	373.0	12.0	377.0	6,566	0	-4,320
385.0	373.0	12.0	379.5	5,875	0	-5,184
385.0	373.0	12.0	382.0	4,838	0	-6,566
385.0	373.0	12.0	384.5	5,184	0	-11,750
385.0	373.0	12.0	387.0	6,048	0	-14,170

Notes: Wickets Nos. 2, 3, 4, and 5 lowered.

Positive force indicates tension in the hoist chain; negative force indicates an opposite force required to hold the wicket in position or to lower it.

Table 7

OPERATING FORCE -- REVISED CURVED-TYPE WICKET IN NO. 15 POSITION (SIMULATED)

<u>Pool Elev</u>		<u>Head Differential</u>	<u>Elevation Top</u>	<u>Force Required to</u>	<u>Force Required to Hold</u>	<u>Force Required to</u>
<u>Upper</u>	<u>Lower</u>	<u>Ft</u>	<u>of Wicket</u>	<u>Raise Wicket, Lb</u>	<u>Wicket in Position, Lb</u>	<u>Lower Wicket, Lb</u>
385.0	384.0	1.0	367.0	10,195	9,504	0
385.0	384.0	1.0	369.5	10,022	8,640	0
385.0	384.0	1.0	372.0	10,022	8,640	0
385.0	384.0	1.0	374.5	9,158	8,640	0
385.0	384.0	1.0	377.0	8,294	6,739	0
385.0	384.0	1.0	379.5	8,640	6,566	0
385.0	384.0	1.0	382.0	8,986	5,184	0
385.0	384.0	1.0	384.5	9,504	4,320	0
385.0	384.0	1.0	387.0	9,850	3,456	0
385.0	378.0	7.0	367.0	11,059	10,022	0
385.0	378.0	7.0	369.5	10,866	9,677	0
385.0	378.0	7.0	370.75	10,022	5,184	0
385.0	378.0	7.0	372.0	9,677	3,456	0
385.0	378.0	7.0	374.5	9,158	864	0
385.0	378.0	7.0	375.75	8,886	173	- 1,728
385.0	378.0	7.0	377.0	9,158	0	- 3,456
385.0	378.0	7.0	379.5	8,981	0	- 5,878
385.0	378.0	7.0	382.0	7,603	0	- 8,640
385.0	378.0	7.0	384.5	8,294	0	- 9,677
385.0	378.0	7.0	387.0	8,988	0	-10,714
385.0	373.0	12.0	367.0	14,342	12,787	0
385.0	373.0	12.0	369.5	13,824	9,677	0
385.0	373.0	12.0	370.75	14,342	6,912	0
385.0	373.0	12.0	372.0	13,997	6,048	0
385.0	373.0	12.0	373.0	13,824	1,728	0
385.0	373.0	12.0	374.0	13,478	346	0
385.0	373.0	12.0	374.5	12,788	0	- 1,555
385.0	373.0	12.0	377.0	10,886	0	-11,059
385.0	373.0	12.0	379.5	6,912	0	-16,934
385.0	373.0	12.0	382.0	5,184	0	-19,699
385.0	373.0	12.0	384.5	2,592	0	-20,736
385.0	373.0	12.0	387.0	4,320	0	-21,427

Notes: Wickets Nos. 2, 3, 4, and 5 raised.

Positive force indicates tension in the hoist chain; negative force indicates an opposite force required to hold the wicket in position or to lower it.

PLATES

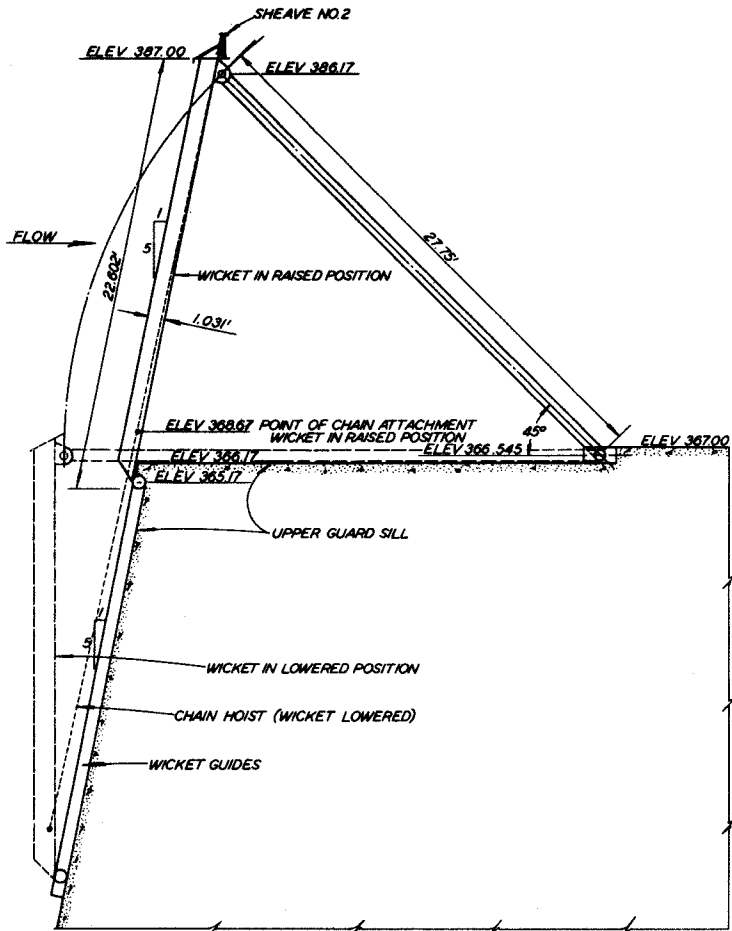

ELEVATION

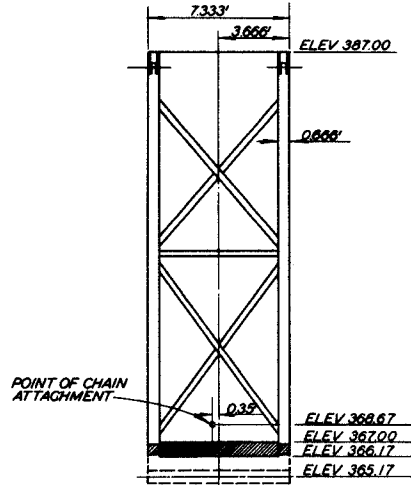

DOWNSTREAM ELEVATION
WICKET RAISED

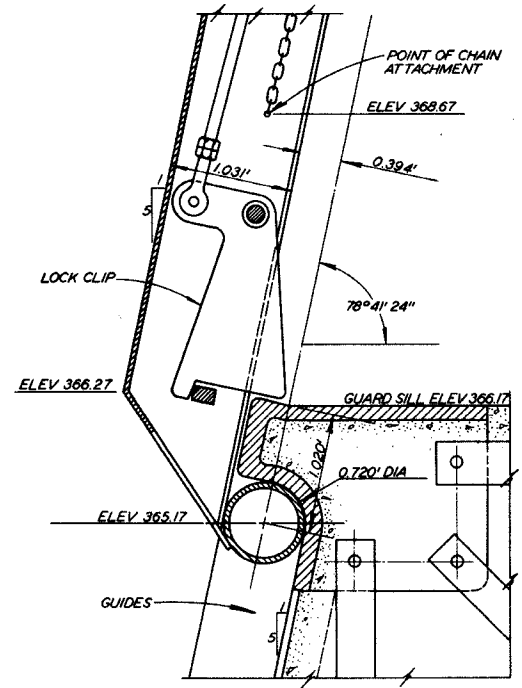

DETAILS OF WICKET LIP

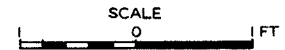

ORIGINAL WICKET DESIGN

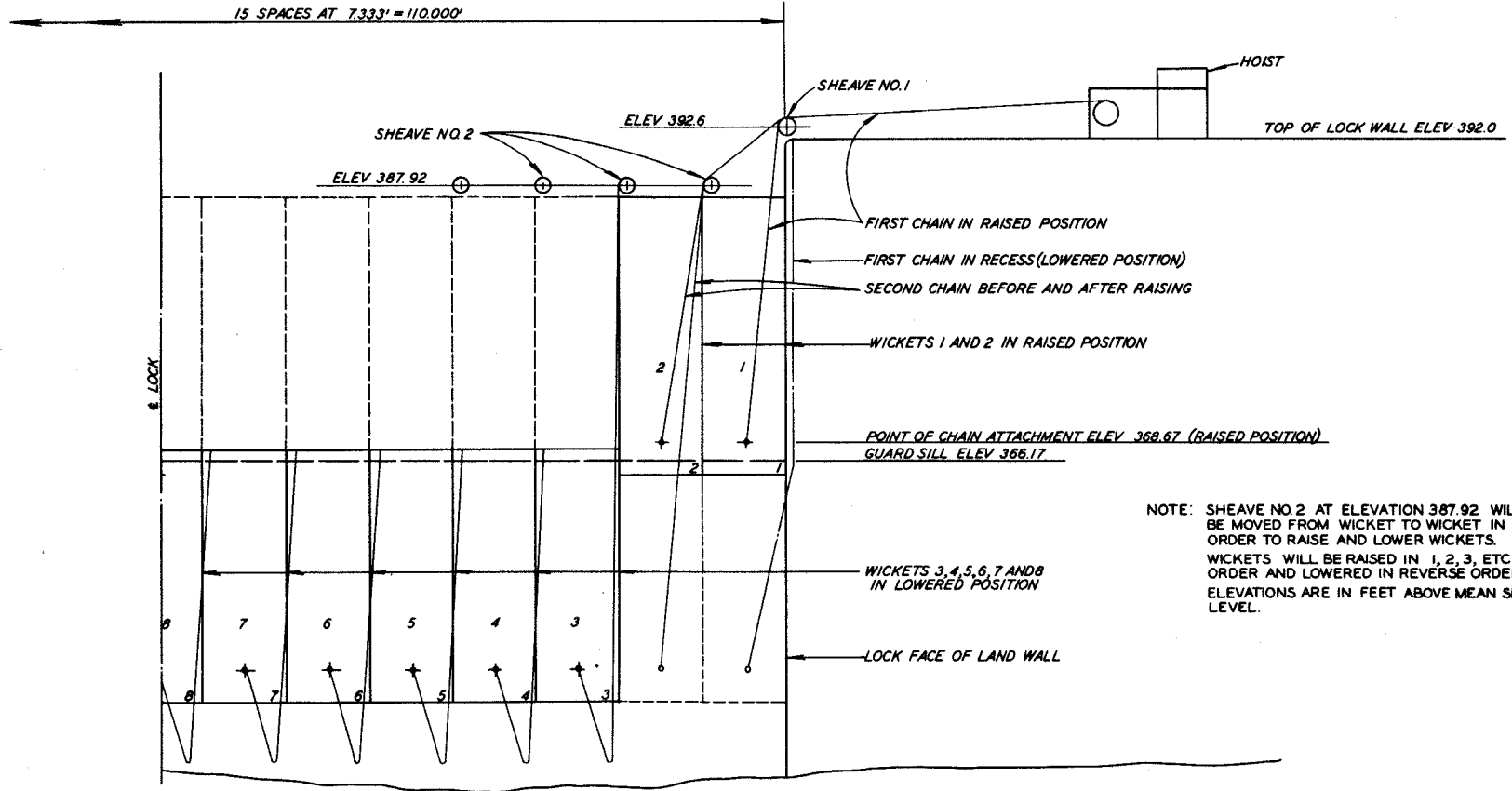

NOTE: SHEAVE NO. 2 AT ELEVATION 387.92 WILL BE MOVED FROM WICKET TO WICKET IN ORDER TO RAISE AND LOWER WICKETS. WICKETS WILL BE RAISED IN 1, 2, 3, ETC ORDER AND LOWERED IN REVERSE ORDER. ELEVATIONS ARE IN FEET ABOVE MEAN SEA LEVEL.



SCHEMATIC WICKET OPERATION

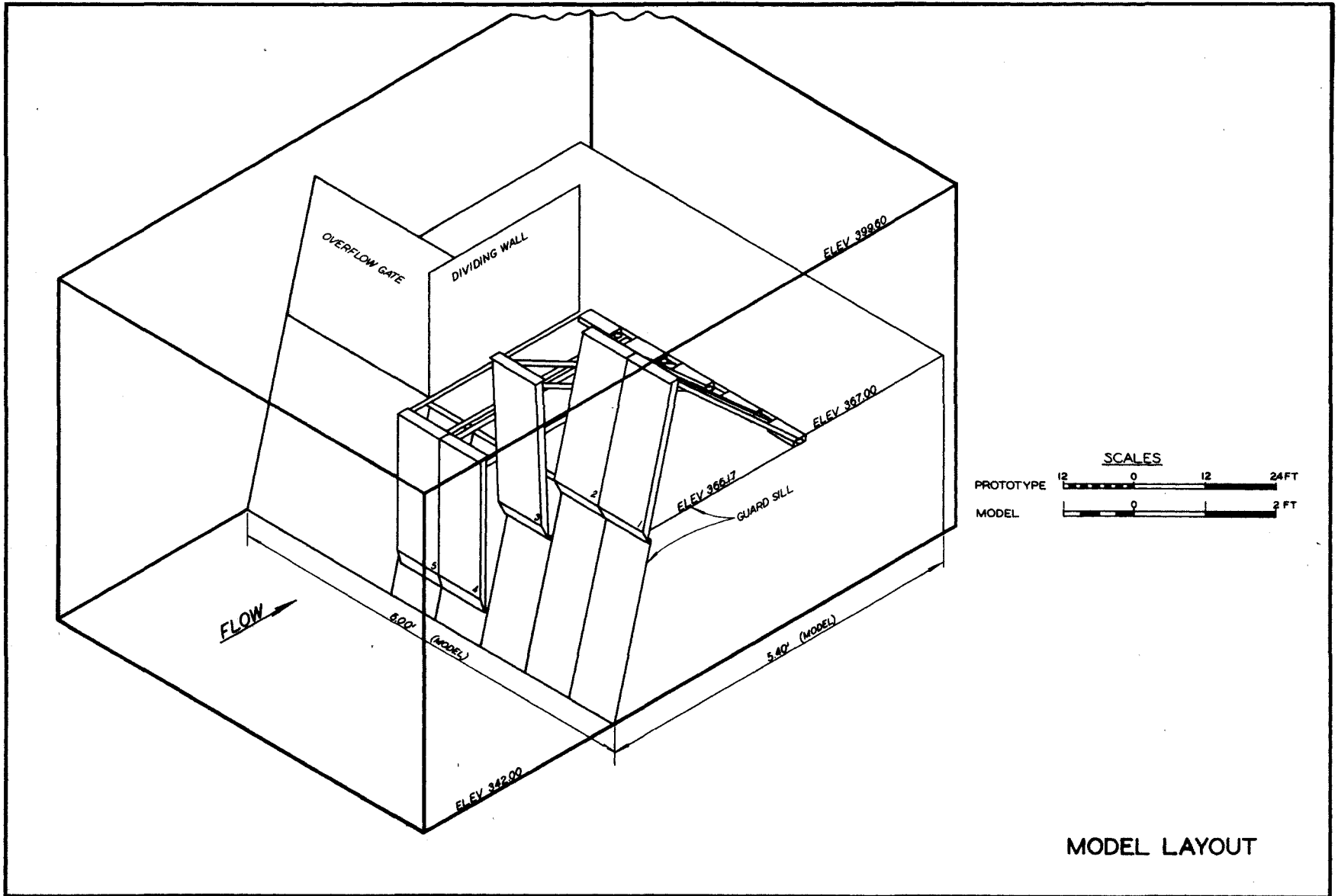

MODEL LAYOUT

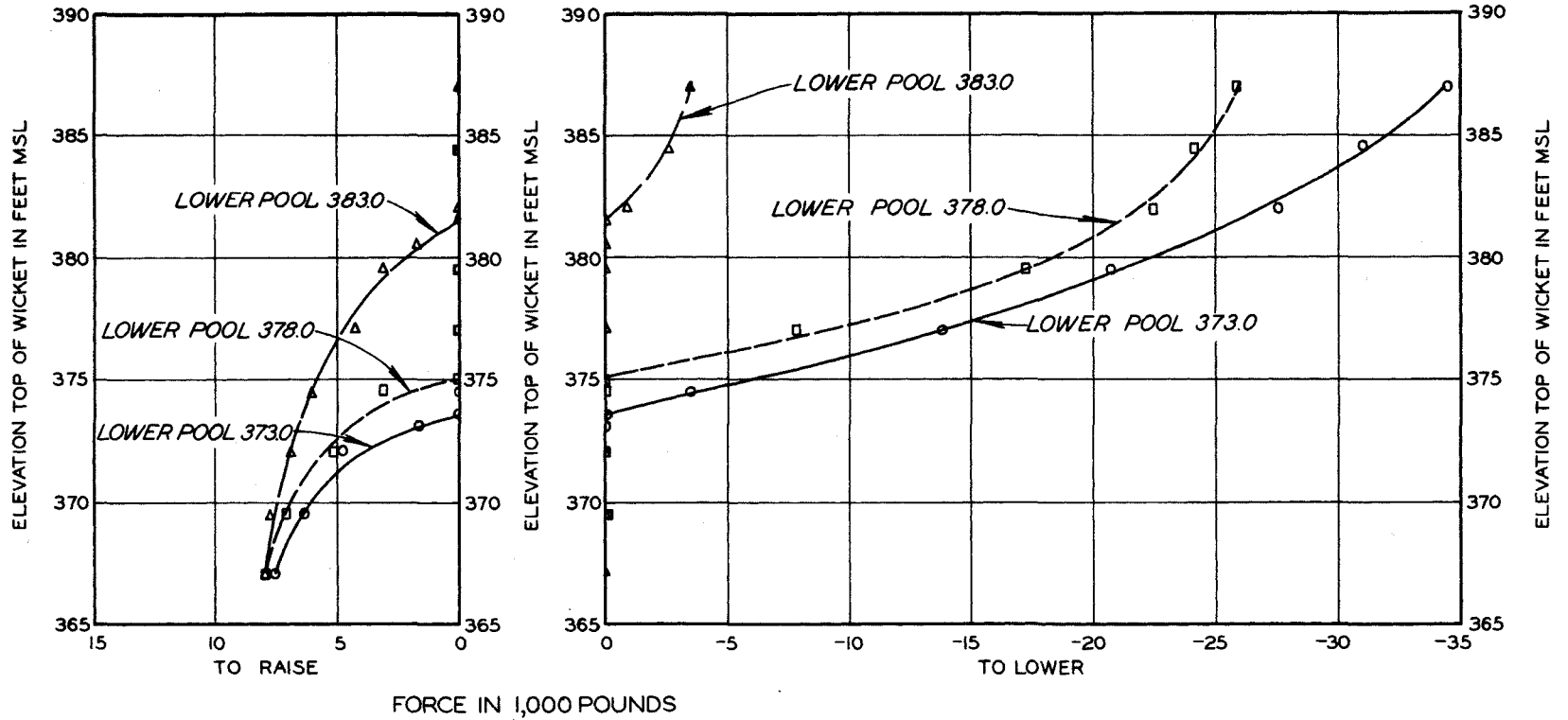

TEST CONDITIONS

WICKET 3 TEST WICKET.
 WICKETS 1 AND 2 RAISED, 4 AND 5 LOWERED.
 UPPER POOL ELEVATION 385.0

NOTE: POSITIVE FORCES INDICATE TENSION IN THE HOIST CHAIN; NEGATIVE FORCES INDICATE A DOWNWARD THRUST REQUIRED TO OPEN THE WICKET.

OPERATING FORCES
 ORIGINAL DESIGN WICKET

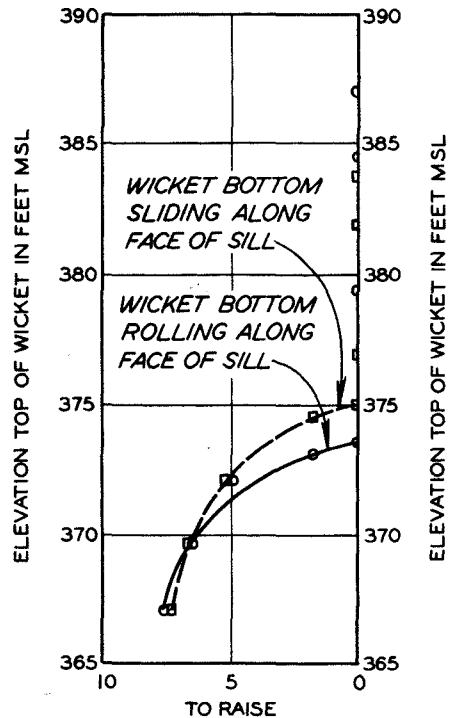

FORCE IN 1,000 POUNDS

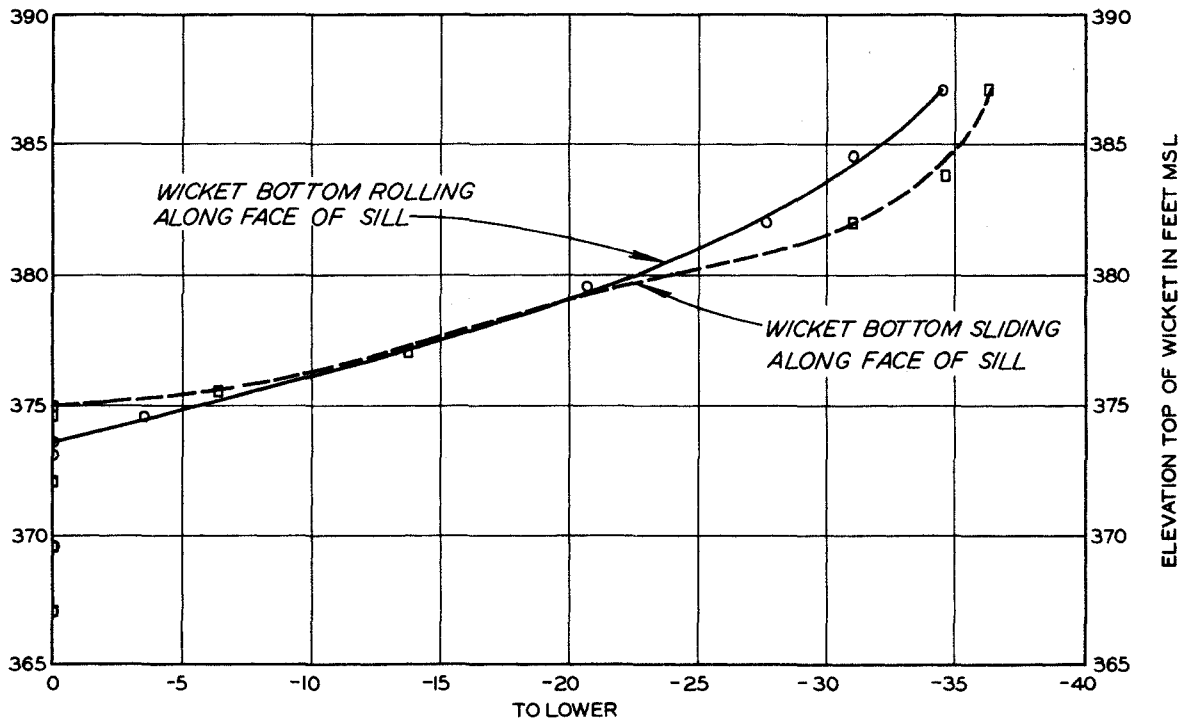

TEST CONDITIONS

WICKET 3 TEST WICKET.
 WICKETS 1 AND 2 RAISED, 4 AND 5 LOWERED.
 UPPER POOL ELEVATION 385.0
 LOWER POOL ELEVATION 373.0

NOTE: POSITIVE FORCES INDICATE TENSION IN THE HOIST CHAIN; NEGATIVE FORCES INDICATE A DOWNWARD THRUST REQUIRED TO OPEN THE WICKET.

OPERATING FORCES
 WICKET SLIDING VS WICKET ROLLING

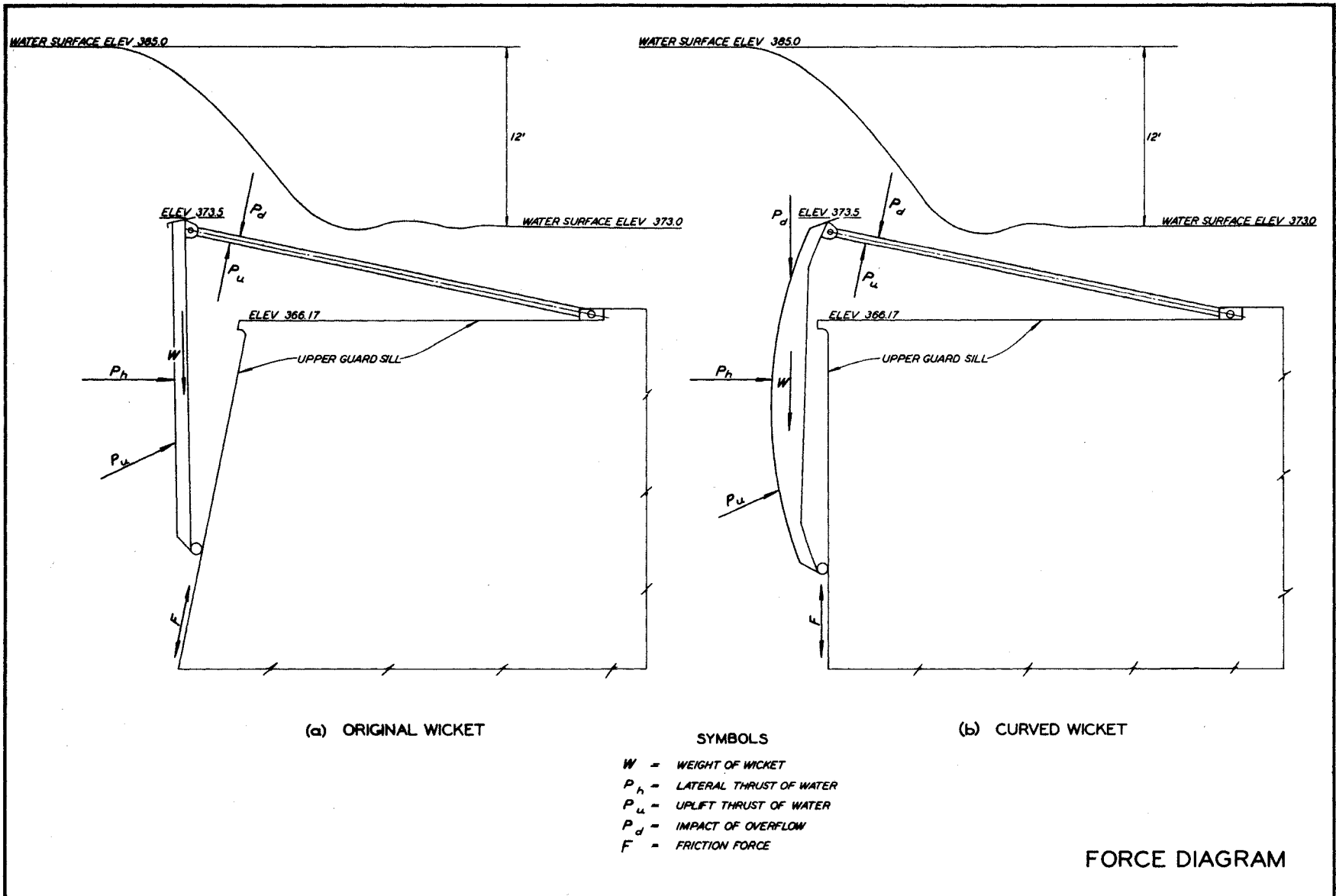

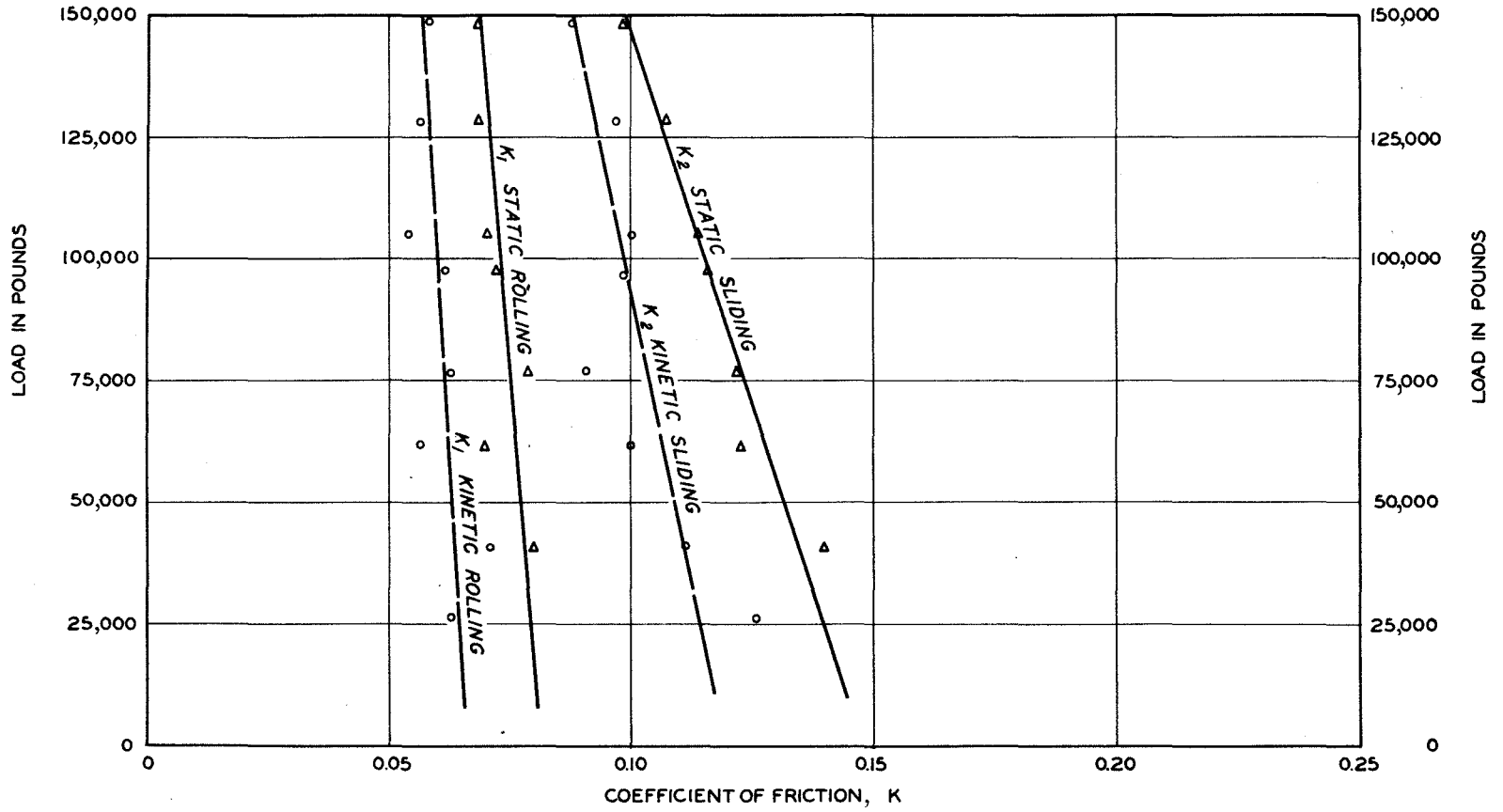

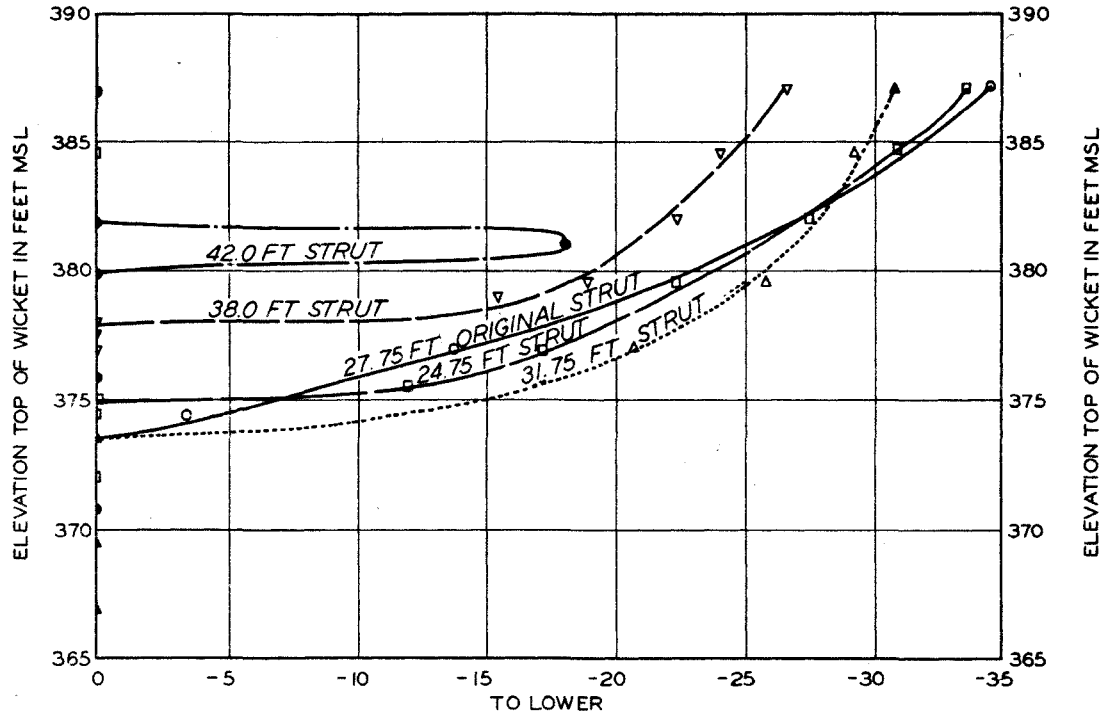
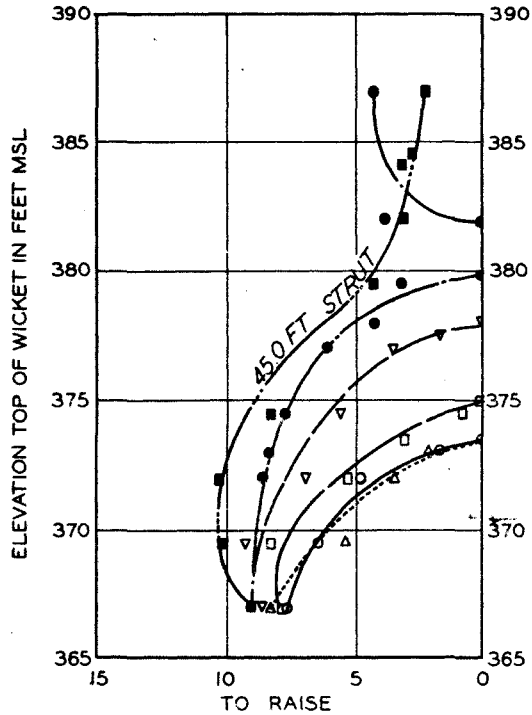

FORCE IN 1,000 POUNDS

TEST CONDITIONS

WICKET 3 TEST WICKET.
 WICKETS 1 AND 2 RAISED, 4 AND 5 LOWERED.
 UPPER POOL ELEVATION 385.0
 LOWER POOL ELEVATION 373.0

NOTE: POSITIVE FORCES INDICATE TENSION IN THE HOIST CHAIN; NEGATIVE FORCES INDICATE A DOWNWARD THRUST REQUIRED TO OPEN THE WICKET.

OPERATING FORCES
 ORIGINAL DESIGN WICKET-ALTERNATE STRUTS

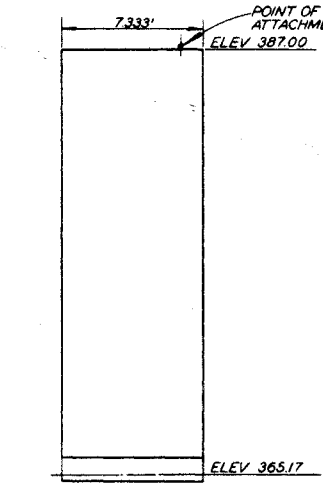
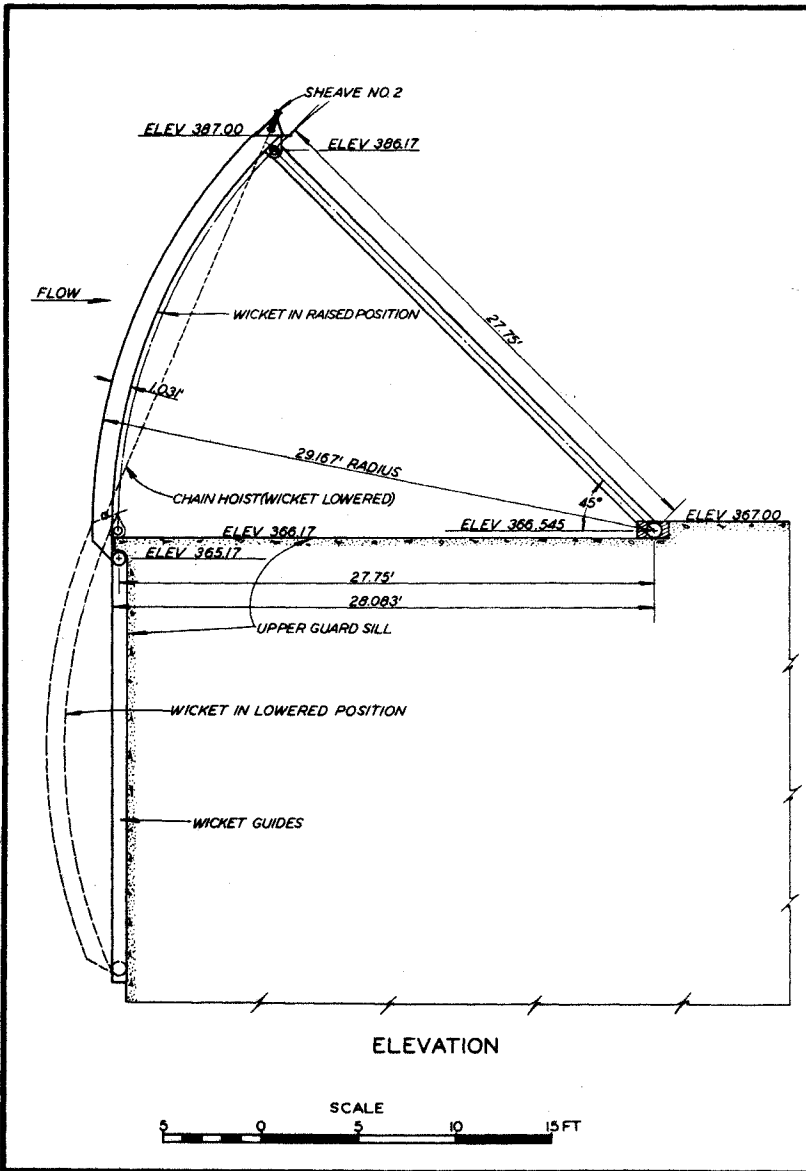

UPSTREAM ELEVATION
WICKET RAISED

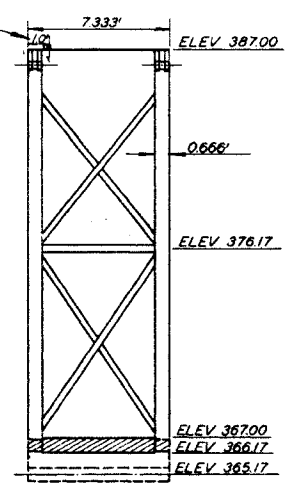

DOWNSTREAM ELEVATION
WICKET RAISED

CURVED WICKET DESIGN

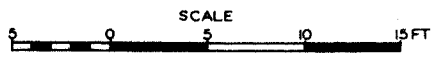

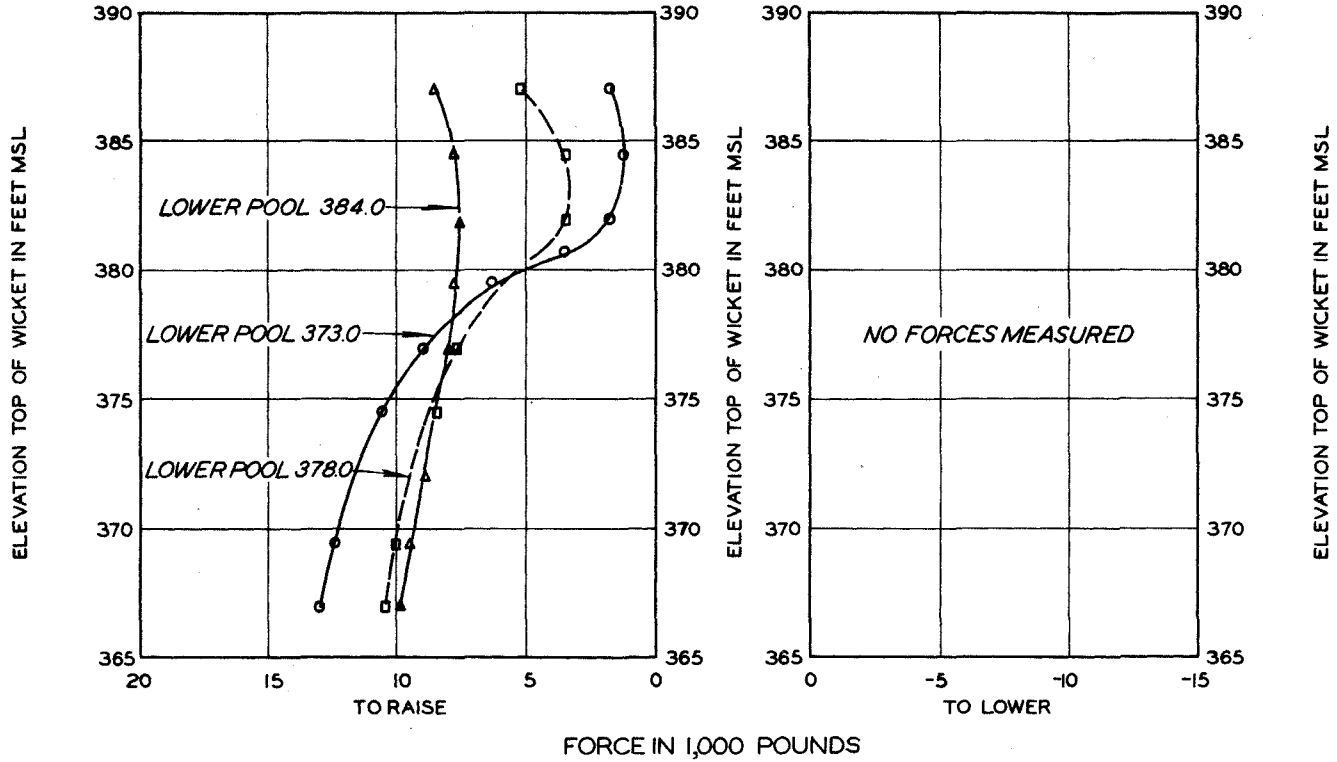

TEST CONDITIONS
 WICKET 3 TEST WICKET.
 WICKETS 1 AND 2 RAISED, 4 AND 5 LOWERED.
 UPPER POOL ELEVATION 385.0

NOTE: POSITIVE FORCES INDICATE TENSION IN THE HOIST CHAIN.

OPERATING FORCES
 CURVED WICKET

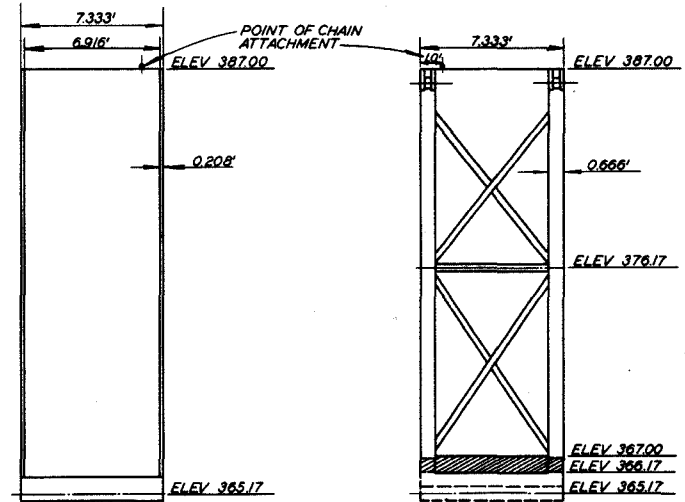
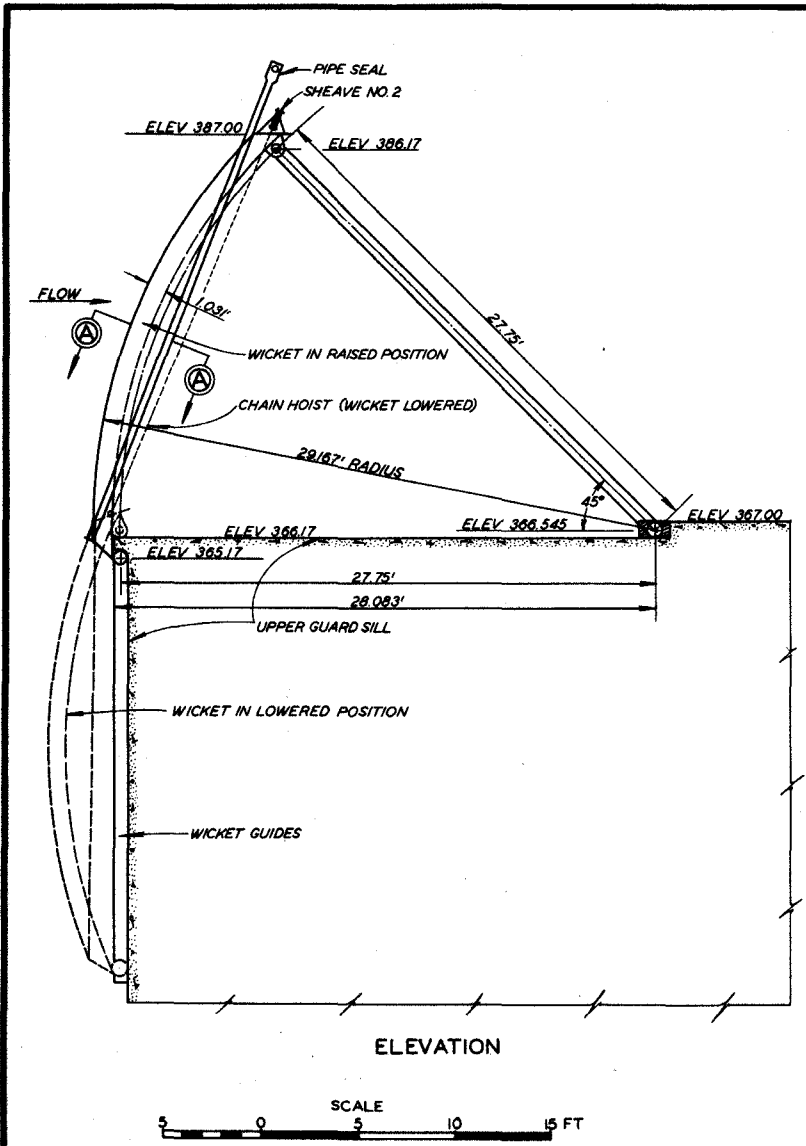

UPSTREAM ELEVATION WICKET RAISED
DOWNSTREAM ELEVATION WICKET RAISED

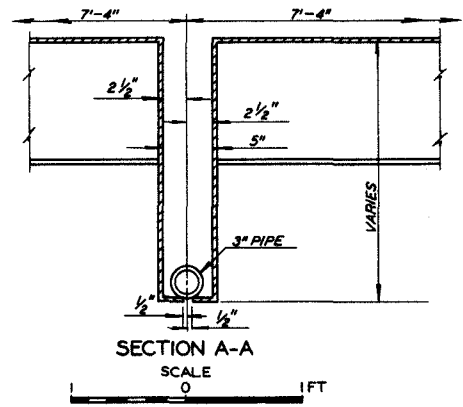

CURVED WICKET REVISED DESIGN

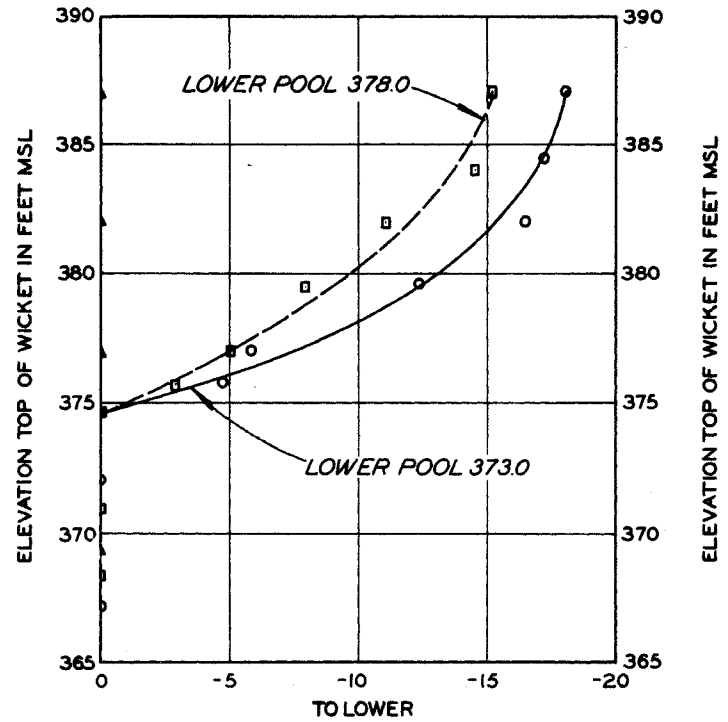
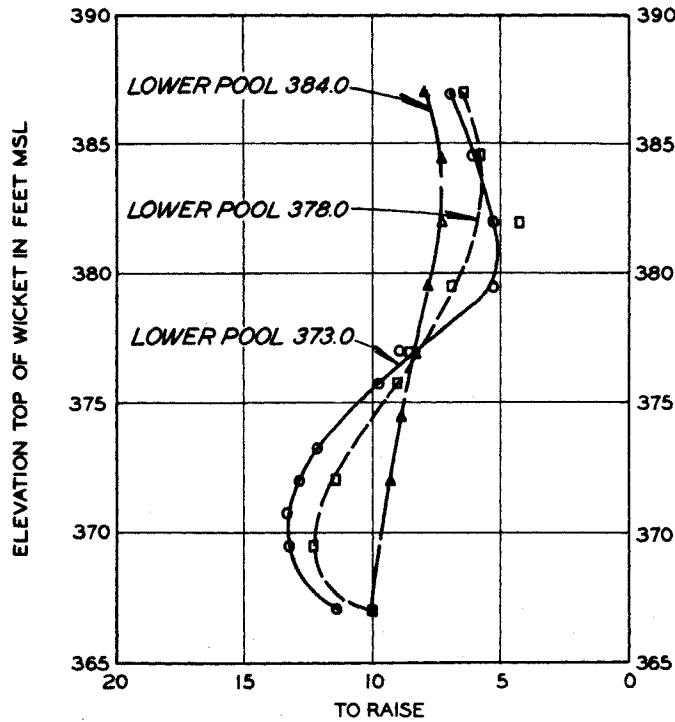

FORCE IN 1,000 POUNDS

TEST CONDITIONS

WICKET 3 TEST WICKET.
 WICKETS 1 AND 2 RAISED, 4 AND 5 LOWERED.
 UPPER POOL ELEVATION 385.0

NOTE: POSITIVE FORCES INDICATE TENSION IN THE HOIST CHAIN; NEGATIVE FORCES INDICATE A DOWNWARD THRUST REQUIRED TO OPEN THE WICKET.

OPERATING FORCES
 REVISED CURVED WICKET