

747  
W34  
no. 2  
381  
EQ

CORPS OF ENGINEERS, U. S. ARMY

---

SUBMERGIBLE-TYPE TAITNER GATE FOR SPILLWAY  
CHEATHAM LOCK AND DAM  
CUMBERLAND RIVER, TENNESSEE

HYDRAULIC MODEL INVESTIGATION

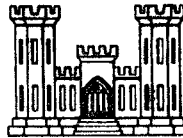

TECHNICAL MEMORANDUM NO. 2-381

CONDUCTED FOR

NASHVILLE DISTRICT, CORPS OF ENGINEERS

BY

WATERWAYS EXPERIMENT STATION

VICKSBURG, MISSISSIPPI

---

ARMY-MRC VICKSBURG, MISS.

APRIL 1954

PROPERTY OF U. S. ARMY  
OFFICE CHIEF OF ENGINEERS  
LIBRARY

# Report Documentation Page

Form Approved  
OMB No. 0704-0188

Public reporting burden for the collection of information is estimated to average 1 hour per response, including the time for reviewing instructions, searching existing data sources, gathering and maintaining the data needed, and completing and reviewing the collection of information. Send comments regarding this burden estimate or any other aspect of this collection of information, including suggestions for reducing this burden, to Washington Headquarters Services, Directorate for Information Operations and Reports, 1215 Jefferson Davis Highway, Suite 1204, Arlington VA 22202-4302. Respondents should be aware that notwithstanding any other provision of law, no person shall be subject to a penalty for failing to comply with a collection of information if it does not display a currently valid OMB control number.

1. REPORT DATE <b>APR 1954</b>		2. REPORT TYPE		3. DATES COVERED <b>00-00-1954 to 00-00-1954</b>	
4. TITLE AND SUBTITLE <b>Submergible-type Tainter Gate for Spillway, Cheatham Lock and Dam, Cumberland River, Tennessee: Hydraulic Model Investigation</b>				5a. CONTRACT NUMBER	
				5b. GRANT NUMBER	
				5c. PROGRAM ELEMENT NUMBER	
6. AUTHOR(S)				5d. PROJECT NUMBER	
				5e. TASK NUMBER	
				5f. WORK UNIT NUMBER	
7. PERFORMING ORGANIZATION NAME(S) AND ADDRESS(ES) <b>U.S. Army Corps of Engineers, Waterway Experiment Station, 3903 Halls Ferry Road, Vicksburg, MS, 39180</b>				8. PERFORMING ORGANIZATION REPORT NUMBER	
9. SPONSORING/MONITORING AGENCY NAME(S) AND ADDRESS(ES)				10. SPONSOR/MONITOR'S ACRONYM(S)	
				11. SPONSOR/MONITOR'S REPORT NUMBER(S)	
12. DISTRIBUTION/AVAILABILITY STATEMENT <b>Approved for public release; distribution unlimited</b>					
13. SUPPLEMENTARY NOTES					
14. ABSTRACT					
15. SUBJECT TERMS					
16. SECURITY CLASSIFICATION OF:			17. LIMITATION OF ABSTRACT	18. NUMBER OF PAGES	19a. NAME OF RESPONSIBLE PERSON
a REPORT <b>unclassified</b>	b ABSTRACT <b>unclassified</b>	c THIS PAGE <b>unclassified</b>			

## PREFACE

Model investigations of the submergible-type tainter gate for the spillway of Cheatham Lock and Dam, Cumberland River, Tennessee, were authorized by the Chief of Engineers, Department of the Army, in second indorsement, dated 19 October 1949, to a letter from the Director, Waterways Experiment Station, Corps of Engineers, Vicksburg, Mississippi, dated 1 September 1949. A supplementary authorization for tests of a single, larger scale gate was received in a letter dated 9 March 1951 from the District Engineer, Nashville District, Corps of Engineers, to the Director of the Waterways Experiment Station. All studies were conducted at the Waterways Experiment Station during the period October 1949 to January 1952.

Mr. J. H. Douma of the Office, Chief of Engineers, Messrs. E. E. Abbott, R. L. Irwin and F. R. Jones of the Ohio River Division, and Col. H. Walsh, District Engineer, Messrs. V. M. Cone, G. O. Prados, H. T. Glenn, H. Blazek, J. Mathewson, R. H. Tuggle, and A. H. Kenigsberg of the Nashville District, visited the Waterways Experiment Station during the course of the model studies to discuss tests results and to correlate these results with design work concurrently being carried on in the District Office.

Engineers of the Experiment Station actively connected with the model studies were Messrs. F. R. Brown, T. E. Murphy, T. J. Buntin, R. O. Cleveland, and J. H. Ables, Jr.

## CONTENTS

	<u>Page</u>
PREFACE . . . . .	i
SUMMARY . . . . .	v
PART I: INTRODUCTION . . . . .	1
Cheatham Lock and Dam . . . . .	1
The Problem . . . . .	2
PART II: THE MODELS . . . . .	3
Description . . . . .	3
Model Appurtenances and Their Application . . . . .	4
Scale Relationships . . . . .	6
PART III: TESTS AND RESULTS . . . . .	7
Test Procedure . . . . .	7
Tests of the Original Design (Plan 1) Gate . . . . .	7
Tests of Alterations to Plan 1 Gate . . . . .	8
Tests of Revised Design (Plan 2) Gate . . . . .	9
Tests of Alterations to Plan 2 Gate . . . . .	10
Tests of 1:10-scale Gate, Plan 2, Alternate E . . . . .	11
Spillway Rating . . . . .	18
Tests of Plan 3 Gate . . . . .	18
Final Design Gate . . . . .	19
Stilling Basin Tests, Final Design Gate . . . . .	19
PART IV: DISCUSSION OF RESULTS . . . . .	21
TABLES 1-15	
PLATES 1-34	

## SUMMARY

Tests were conducted on a 1:36-scale model of the submergible-type tainter gate proposed for use on the spillway at Cheatham Lock and Dam. These tests were concerned with the determination of the hydraulic characteristics of the gate as demonstrated by the force required to raise and lower the gate under all possible operating conditions. The tests showed that the gate as originally designed was unsatisfactory because of its instability, and the uplift forces and high downpull forces exerted on it. As the test gate was raised, pressure conditions over the gate were such as to cause it to oscillate. Downpull forces were as high as 650 kips or about twice those considered allowable.

Revisions to the crest and over-all shape of the gate together with proper venting eliminated all uplift forces tending to float the gate, and reduced downpull forces to within allowable limits. The tendency of the gate to oscillate also was eliminated by the design developed from the model tests. Results of tests on the 1:36-scale model were confirmed by later tests on a 1:10-scale model.

The actual design of gate adopted for construction in the prototype was a semisubmergible type; flow is to be passed over this gate up to a head of 7 ft, after which the gate will be raised and all flow will pass under it. This type gate was not tested in the model except for stilling basin tests that were conducted using a schematic reproduction of the final-type gate. These tests indicated that a horizontal apron, 64 ft in length at elevation 345, and a 9-ft-high end sill would be most effective in stilling flow passing either over or under the gate.

SUBMERGIBLE-TYPE TAITNER GATE FOR SPILLWAY  
CHEATHAM LOCK AND DAM, CUMBERLAND RIVER, TENNESSEE

Hydraulic Model Investigation

PART I: INTRODUCTION

Cheatham Lock and Dam

1. Cheatham Lock and Dam, under construction on the Cumberland River about 20 mi above Clarksville, Tennessee, (fig. 1) is an important unit in the network of navigable waters of the Ohio and Mississippi River systems. This structure will provide a needed increase in depth at Nashville, the terminal point of most of the river traffic, and will eliminate the need for two outdated and troublesome existing locks and dams.

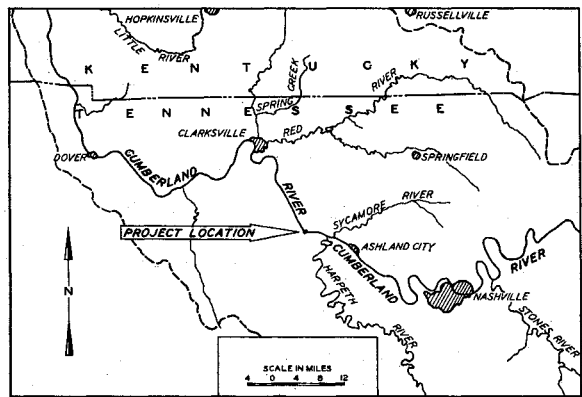

Fig. 1

2. The dam will be of the nonnavigable, gated type. Its spillway will consist of a concrete sill at elevation 359\* surmounted by seven tainter gates each 63.5 ft long by 27.5 ft high. Concrete piers 10 ft wide will take the gate thrust and support individual gate hoists and a structural steel service bridge. In the initial design, the gates were 59.75 ft long by 27.0 ft high with 9-ft-wide piers, and were to operate under submerged conditions at all times (see plate 1). The skin plate of the gates was shaped to fit the lower nappe of a sharp-crested weir inclined upstream at an angle of 45 degrees. Final plans, however, involved use of a semisubmergible-type gate; this gate is planned for a maximum submergence of about 7 ft below normal pool

---

\* All elevations are in feet above mean sea level.

elevation of 385, after which it will be raised and flow will pass under it. A short, horizontal apron-type stilling basin with an end sill will be used to dissipate flow passing over or under the tainter control gates.

3. The lock will be set into the right bank floodplain with the riverward wall at about the natural bank line. The lock chamber will have a clear width of 110 ft and a length of 800 ft. Lock gates will be of the horizontally-framed miter type, with hydraulic operating machinery. The filling and emptying system will be of the conventional longitudinal-culvert and side-chamber-port type with reverse tainter valves.

#### The Problem

4. The unprecedented plan of operating tainter control gates in a submerged condition for the full range of heads made it desirable to conduct hydraulic model studies to investigate the hydraulic characteristics of the submergible-type gate proposed and to correct any undesirable conditions found to exist. In addition, studies were to be conducted of the arrangement and effectiveness of stilling basin elements such as baffle piers and end sill.

## PART II: THE MODELS

Description

5. A section model of the spillway and submergible tainter gate was constructed initially to a scale of 1:36 (fig. 2 and plate 2) and reproduced one whole gate bay with adjacent half bays, 334 ft of approach channel, and 540 ft of exit area. The portion of the model representing the spillway sill and apron was molded in concrete to sheet-metal templates; the gate piers were fabricated of plastic. The test gate was reproduced accurately to scale in size, shape, and weight. The prototype gate was estimated to weigh 90 tons as compared to a model equivalent weight of 92.5 tons. The two adjacent half gates were simulated schematically and reproduced only the shape and size of the submergible-type gate. The structural members of the test gate

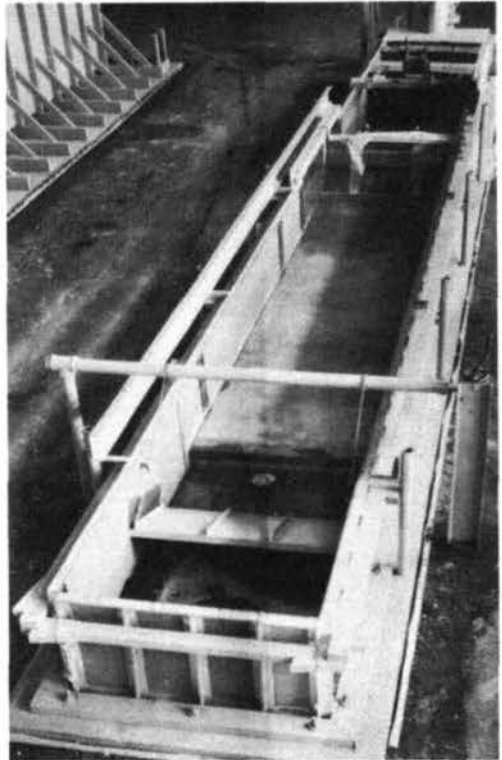

Fig. 2. Upstream view, 1:36-scale model, original design

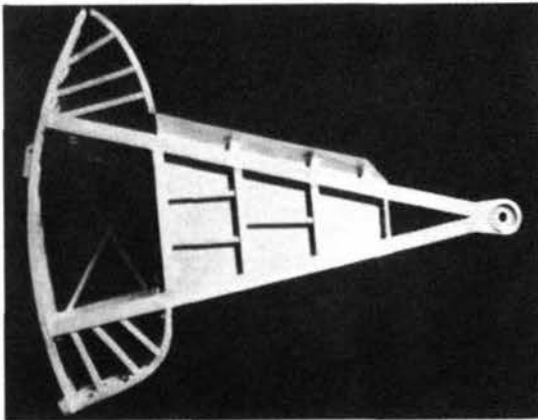

Fig. 3. Gate without skin plate

and skin plate were fabricated of brass (fig. 3). The gate was operated manually at the prototype speed of one-half foot per minute. To reduce friction forces to a minimum the gate trunnions were mounted in roller bearings in the adjacent gate piers.

6. After development of a satisfactory gate design on the

1:36-scale model, it was desired to check test results obtained with this gate on a larger scale model. Accordingly a second section model was constructed in an existing flume and reproduced, to a scale of 1:10, one complete test gate, two piers, the spillway sill and apron, 175 ft of approach channel, and 250 ft of exit area (fig. 4 and plate 3). The only difference in the method of construction of the two models was the use of concrete gate piers for the 1:10-scale model.

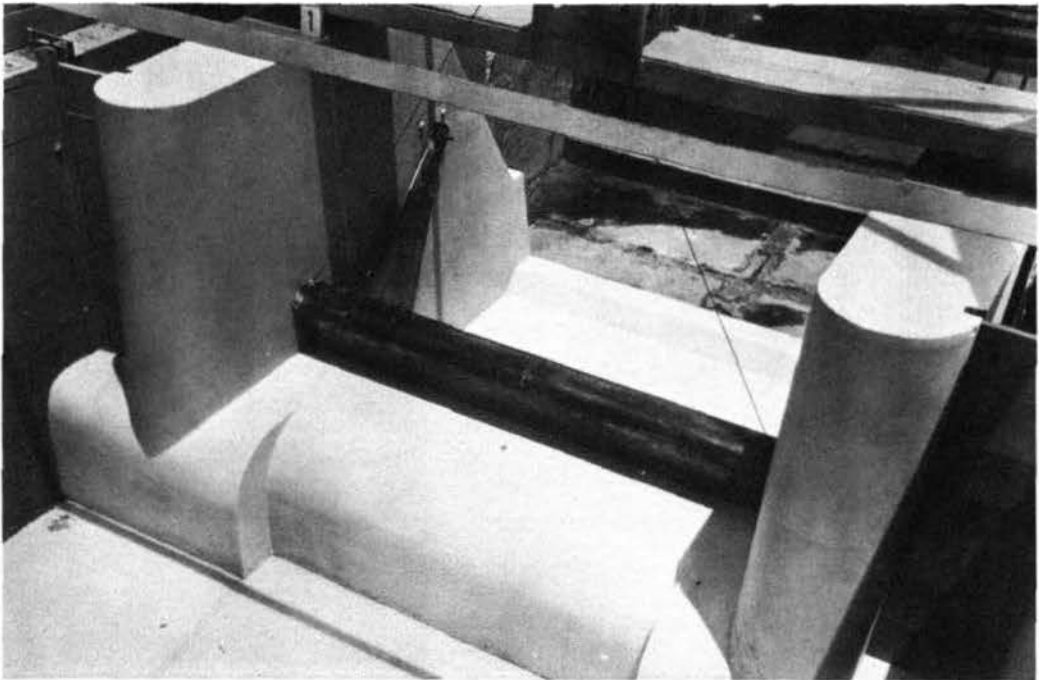

Fig. 4. Downstream view, 1:10-scale model, revised design (plan 2)

#### Model Appurtenances and Their Application

7. Water used in the operation of both models was supplied by centrifugal pumps and discharges were measured by venturi meter and pitometer tubes. Flow from the supply lines spilled into the model headbays where it was stilled by baffles prior to passage into the models. After passing through the models, the water returned to the sump by gravity flow through return lines. The tailwater elevation in the downstream end of the models was controlled by means of an adjustable tailgate. Steel rails, set to grade along either side of the models,

provided a datum plane for the use of measuring devices. Water-surface elevations were measured by means of portable point gages mounted on an aluminum channel. Velocities were measured by means of a pitot tube.

8. All forces acting on the test gate were measured by means of a

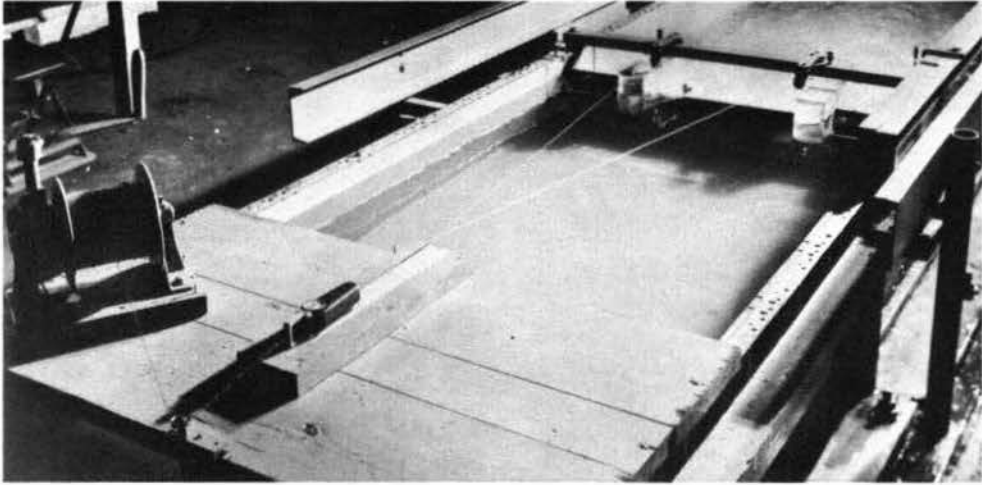

Fig. 5. Force indicator in use on 1:36-scale model gate

force indicator on the 1:36-scale model (fig. 5), and a force meter on the 1:10-scale model (fig. 6). The force indicator was graduated in tenths of pounds and was accurate to the nearest tenth of a pound. The force meter was graduated in ten-pound intervals and was accurate to the nearest ten pounds. All forces were determined by raising or lowering the test gate, with the measuring device attached as part of the hoist chain.

9. Air velocity measurements were made with a velometer head installed in the air intakes of the 1:10-scale model trunnion arm

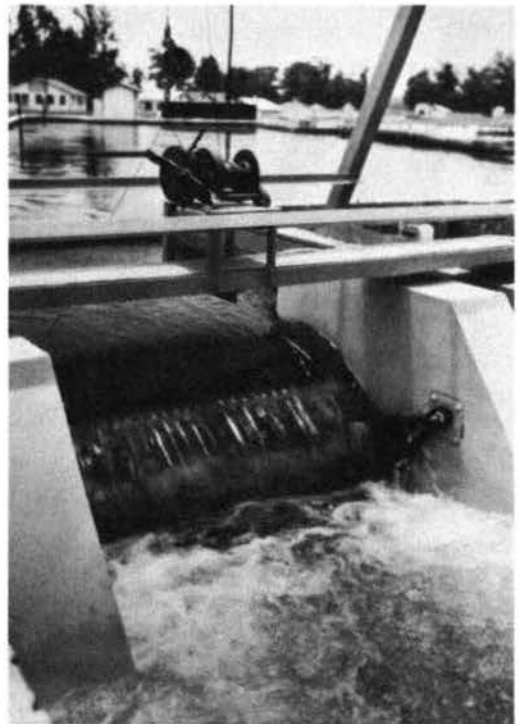

Fig. 6. Force meter in use on 1:10-scale model gate

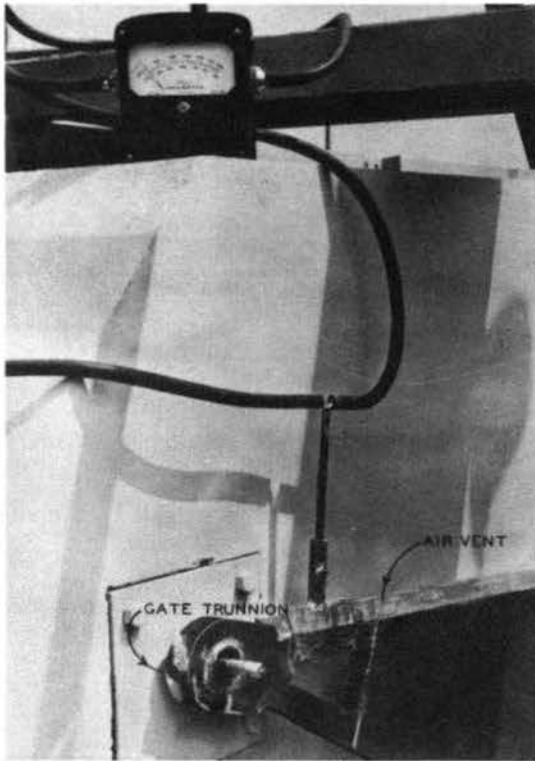

Fig. 7. Velometer measuring air velocity in air vent; plan 2, alternate E gate

(plan 2-E). The velometer consists of a pitot tube head connected by rubber tubing to an indicating meter (fig. 7). The indicator records air velocity; in order to convert to volume the velocity must be multiplied by the area of the air vent.

#### Scale Relationships

10. The requirements for geometric and dynamic similarity between model and prototype were satisfied by constructing all elements of the models to an undistorted linear scale ratio, and testing all hydraulic quantities in their proper relationships as

derived from the Froude law. General scale relationships for the transference of model data to prototype equivalents, or vice versa, were as follows:

<u>Dimension</u>	<u>Ratio</u>	<u>Scale Relationship</u>	
Length	$L_r = L$	1:36	1:10
Time	$T_r = L_r^{1/2}$	1:6	1:3.16
Velocity	$V_r = L_r^{1/2}$	1:6	1:3.16
Weight	$W_r = L_r^3$	1:46,656	1:1,000
Force	$F_r = L_r^3$	1:56,656	1:1,000
Discharge	$Q_r = L_r^{5/2}$	1:7,776	1:316

### PART III: TESTS AND RESULTS

#### Test Procedure

11. Practically all tests were conducted with the headwater, or upper pool level, maintained at a constant elevation of 385. Prior to the start of a test the force-measuring equipment was checked to insure that it was operating properly, the moving parts of the test gate were examined and lubricated, and the water levels in the upper pool and below the gate were properly adjusted. The force-measuring device, having previously been zeroed, was then placed in operation (raising or lowering the test gate). The force required to hold the gate at a particular elevation was measured by raising the crest of the gate to the desired elevation and holding it there for a measurement. The force required to operate the gate was measured by raising or lowering the gate through an elevation and recording the force as the crest passed the given elevation. All force data presented in plots and tables in this report were measured in this manner. The relative merits of each gate design were evaluated chiefly by comparison of forces acting on the test gates. All forces recorded include the weight of the gate.

#### Tests of the Original Design (Plan 1) Gate

12. The original designs for the spillway and submergible tainter gate have been described in paragraph 2; general dimensions are shown on plate 4. For purposes of identification, the original design spillway and gate have been designated plan 1.

13. Measurements of head-discharge relations for various gate openings with pool and tailwater elevations maintained at 385 and 355, respectively, revealed that a maximum discharge of 24,750 cfs was passed through a single gate bay (plate 5). However, maintenance of the proper tailwater elevation reduced this flow to about 14,700 cfs per gate bay (plate 6).

14. Pressure measurements were made on the upstream and downstream skin plates of the plan 1 gate for all operating conditions by means of piezometers located as shown on plate 8. Actual values of the pressure measurements for the gate lowered 7, 14, 21, and 26 ft (fully lowered) below maximum pool elevation of 385 are shown in tables 1-4, respectively. These data indicate that pressure conditions were most critical in the vicinity of the gate crest. A maximum negative pressure of -18 ft of water existed at piezometer 2 for a discharge of 13,200 cfs and a head of 14 ft over the gate. Maximum negative pressure for heads of 7 ft and 21 ft was -4.5 ft. With the gate in the fully lowered position (elev 359) all pressures were positive.

15. Tests to record force measurements as the gate was raised or lowered revealed that the hydraulic performance of the plan 1 gate was unsatisfactory. As the gate crest was lowered below elevation 379 a reversal of forces caused the gate to oscillate. This reversal of forces is attributed to the negative pressure condition in the vicinity of the crest of the gate. A maximum downpull force of 650 kips was measured for a gate elevation of 383 and a tailwater elevation of 355; a maximum uplift force of 250 kips was measured at a gate elevation of 369 and a tailwater elevation of 373 (plate 7).

#### Tests of Alterations to Plan 1 Gate

16. A conference with Nashville representatives was held following test of the plan 1 gate at which it was decided to eliminate this gate from further consideration. Tentative force criteria for selection of a suitable gate design were decided upon, as follows: (a) the maximum allowable limit for downpull should be 300 kips, and (b) all uplift forces should be eliminated. To develop a satisfactory gate design as rapidly as possible, a considerable number of alterations to the plan 1 gate were investigated with only a minimum amount of force data being procured in each instance. Efforts were directed chiefly toward development of a design that would satisfy the tentative force criteria. If a good design could be found, extensive data were to be obtained and

further refinements effected. The alterations tested and results obtained are summarized in plates 8-10 and table 5.

17. Tests of gate alternates A-W indicated that none of the alternates met the criteria for a satisfactory gate design. A broader gate crest alignment tested in an effort to improve pressure conditions relieved the tendency of the gate to oscillate. However, the area exposed to velocity of flow when the gate was in the lowered position was increased and increased downpull forces resulted. Gate alternates T and U came nearest to satisfying the criteria for gate design. Alternate T, with a narrow crest, resulted in low downpull forces but some uplift forces; alternate U with a broad crest and large drain holes in the bottom of the gate resulted in the elimination of uplift forces and a downpull force of about 315 kips which was only slightly in excess of that considered allowable. Although some improvement in gate performance was possible by use of alternate T or alternate U gates, it was decided in conference with engineers of the Nashville District that design and fabrication of a full-scale gate of similar shape was not practicable. Accordingly, efforts were directed toward developing a thinner type gate and aerating the underside of the nappe passing over the gate.

#### Tests of Revised Design (Plan 2) Gate

18. Details of the revised design (plan 2) gate are shown on plate 11. The plan 2 gate consisted of an upstream face of 32-ft radius with the crest of the gate designed in accordance with the exponential curve of the form  $X^{1.85} = 2H_c^{0.85}Y$ , where  $H_c = 7$  ft. The upstream and downstream portions of the gates were joined to the crest by curves with radii of 1.5 and 2.86 ft, respectively. Some differences between the original and revised pier and adjacent gate also were effected by simulation of the rack and pinion arrangement for raising and lowering the gate. Significant differences concerned the width of the pier proper and the offset in pier alignment immediately downstream from the gate. The original pier width was increased from 9 to 10 ft and the offset away from flow immediately downstream from the gate was reduced

from 1.625 ft to 0.5 ft. Weight of the plan 2 gate with pinion guards was 97 tons.

19. Initial tests were conducted with the plan 2 gate and the original design piers and sill. A calibration of gate opening versus pool and tailwater elevations is shown on plate 12. The magnitudes of the pressures recorded for heads of 7, 14, 21, and 26 ft are listed in tables 6-9. Distribution of pressures is shown on plate 13; piezometer locations are shown on plate 15. A maximum negative pressure of -10 ft of water was recorded on piezometer 6 for a head of 21 ft over the gate and tailwater elevations of 364 and 357. Maximum negative pressures for heads of 7 and 14 ft were -2.1 ft and -5.9 ft, respectively.

20. Measurement of forces on the type 2 gate revealed the absence of any uplift force and that downpull forces ranged from 55 to 250 kips. Since the forces measured were within the acceptable range, the piers were altered and the pinion guards were added as indicated in the plans (plate 11). Repeat tests to record forces revealed a maximum downpull force of 265 kips and an uplift force of 14 kips (table 10 and plate 14). The uplift force was attributed to the reduced offset in the pier face which must have reduced the amount of aeration furnished by the offset. Accordingly additional alterations to the type 2 gate were studied to effect further refinements that would reduce the small uplift force.

#### Tests of Alterations to Plan 2 Gate

21. Five alterations to effect refinements in the plan 2 gate design were investigated in an effort to eliminate the uplift force involved. Details of the alterations investigated are shown on plate 15. A description of each alteration and the results obtained are presented in the following subparagraphs.

- a. Plan 2, alternate A. A row of 28 air vents 0.333 ft in diameter and located on 2-ft centers was drilled in the plan 2 gate near the crest to provide additional aeration of the nappe passing over the gate. Uplift forces were eliminated by the addition of the air vents and downpull forces ranged from 20 to 275 kips. Thus, the performance of this type gate was considered satisfactory.

- b. Plan 2, alternate B. A second row of 26 air vents 0.5 ft in diameter on 2-ft centers was added to the plan 2-A gate near the sharp break in the alignment of the downstream face. The additional vents had little effect on gate performance. Downpull forces were in the range of 60 to 265 kips and no uplift forces were observed.
- c. Plan 2, alternate C. A portion of the skin plate on the downstream side of the type 2 gate was removed and vented in lieu of the vents in the crest of the gate. Maximum downpull forces varied between 65 and 240 kips; uplift forces were eliminated.
- d. Plan 2, alternate D. The shape of the bottom of the plan 2-B gate was changed from a curved alignment to a straight sloped alignment. Results of forces acting on the gate were approximately the same as those recorded with the plan 2-B gate.
- e. Plan 2, alternate E. The upper parts of the ends of the plan 2 gate were sealed and two rows of 28 air vents were added near the crest of the gate. A maximum downpull of 317 kips was recorded with a tailwater elevation of 377 and a pool elevation of 385 (plate 16 and table 11); no uplift forces were recorded.

22. All of the alterations to the plan 2 gate resulted in satisfactory performance; i.e., no uplift forces existed, downpull forces were in the range of 300 kips or less, and the gate did not oscillate for any of the tailwater elevations or gate positions tested. All force measurements had been made with the upstream pool at elevation 385. Therefore it was decided to conduct repeat tests with the plan 2-E gate and the pool maintained at elevation 387. Results were somewhat similar to those recorded at a pool elevation of 385 (plate 16 and table 12). No uplift forces were recorded; maximum downpull forces were approximately 350 kips.

#### Tests of 1:10-scale Gate, Plan 2, Alternate E

23. Although the 1:36-scale model of the plan 2-E gate had performed satisfactorily, it was decided to build a 1:10-scale model of the same design to verify the force measurements and to study further refinements. Comparative size of the two gates is shown by fig. 8. Comparative dry weights of the gates are listed on the following page.

<u>Scale</u>	<u>Model Weight</u>	<u>Prototype Weight</u>
1:36	4.30 lb	100.43 tons
1:10	210.84 lb	105.15 tons

The difference in prototype weights of the two gates is believed to be within the limits of accuracy of model measurements and resulted from gate fabrication procedures.

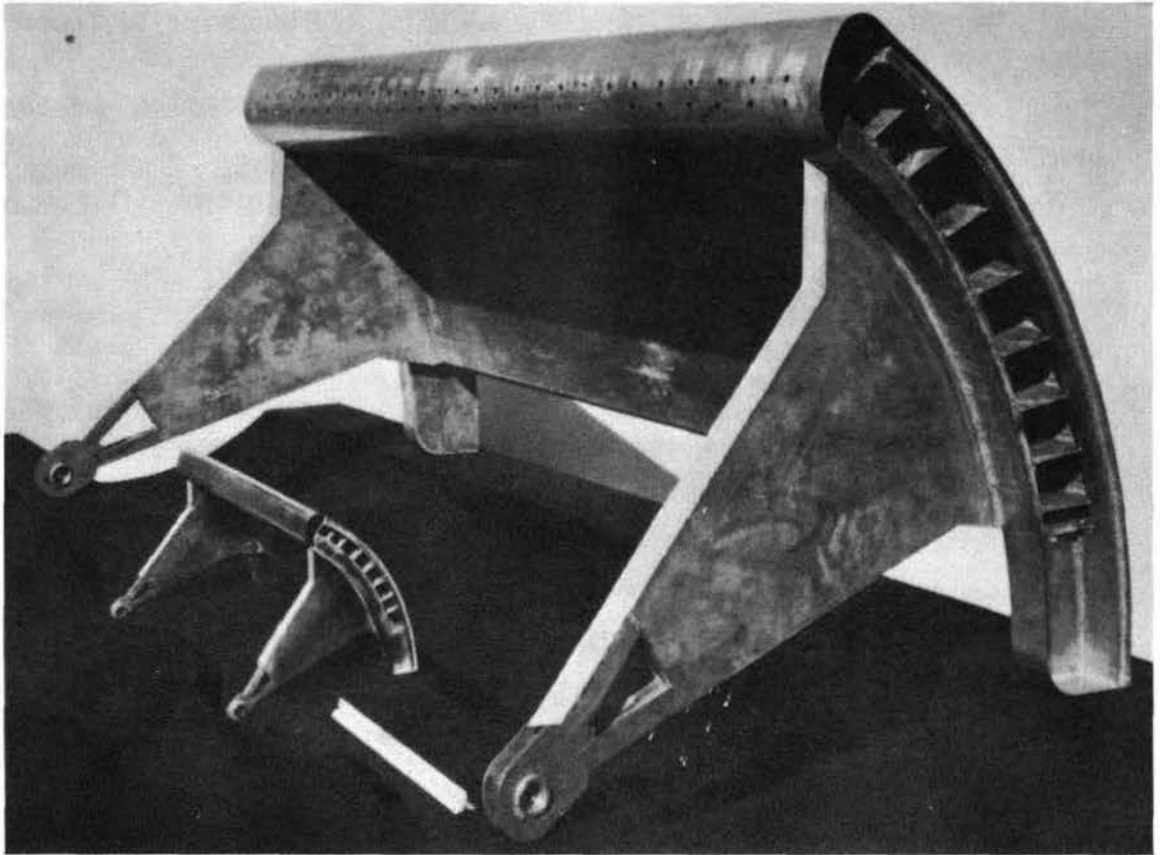

Fig. 8. 1:36- and 1:10-scale models of the plan 2, alternate E gate

#### Downpull forces

24. Comparison of downpull forces recorded on the 1:10- and 1:36-scale models of the plan 2-E gate is shown on plate 17. Good agreement existed between the measurements obtained on the two gates. The gate openings and tailwater conditions, upon instructions of the Nashville District, were maintained in accordance with the 358.6 tailwater rating curve at lock B (plate 22). Flow conditions over the 1:10-scale gate are shown on figs. 9-12. Tests conducted with the ends of the gate

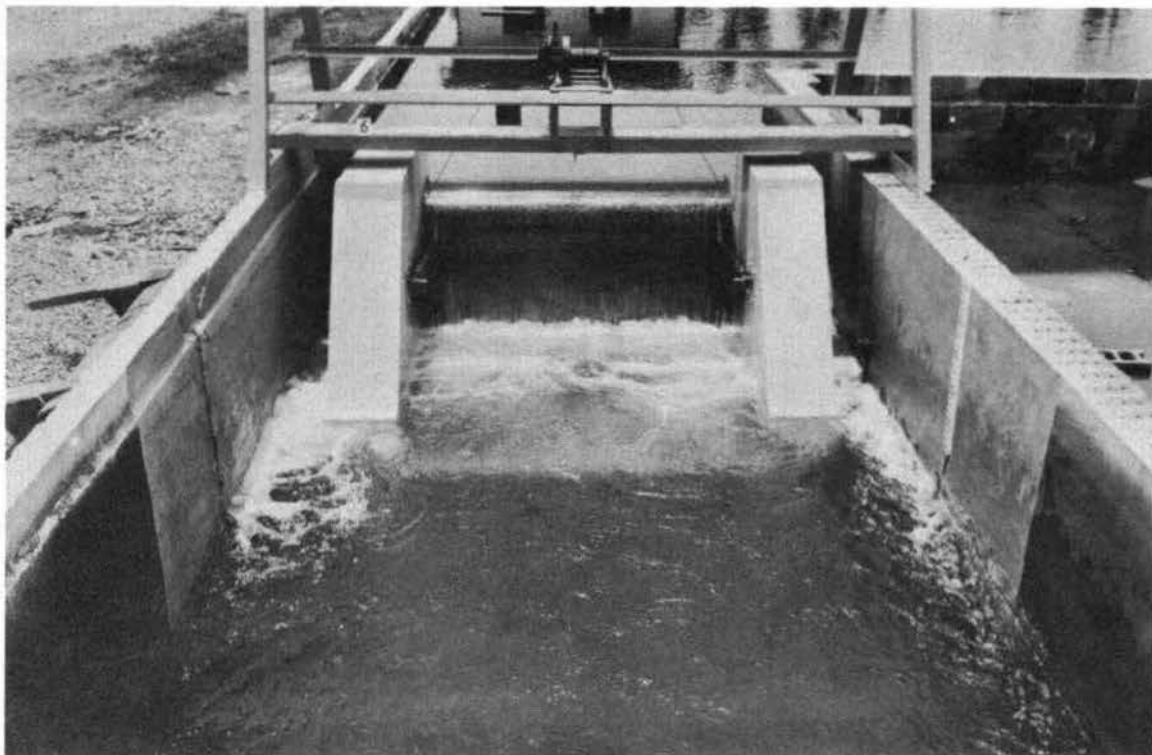

Fig. 9. Flow conditions with 1:10-scale plan 2, alternate E gate installed. Crest at elevation 383.0. Discharge, 850 cfs.  
Elevations of: pool, 385.0; tailwater, 358.6

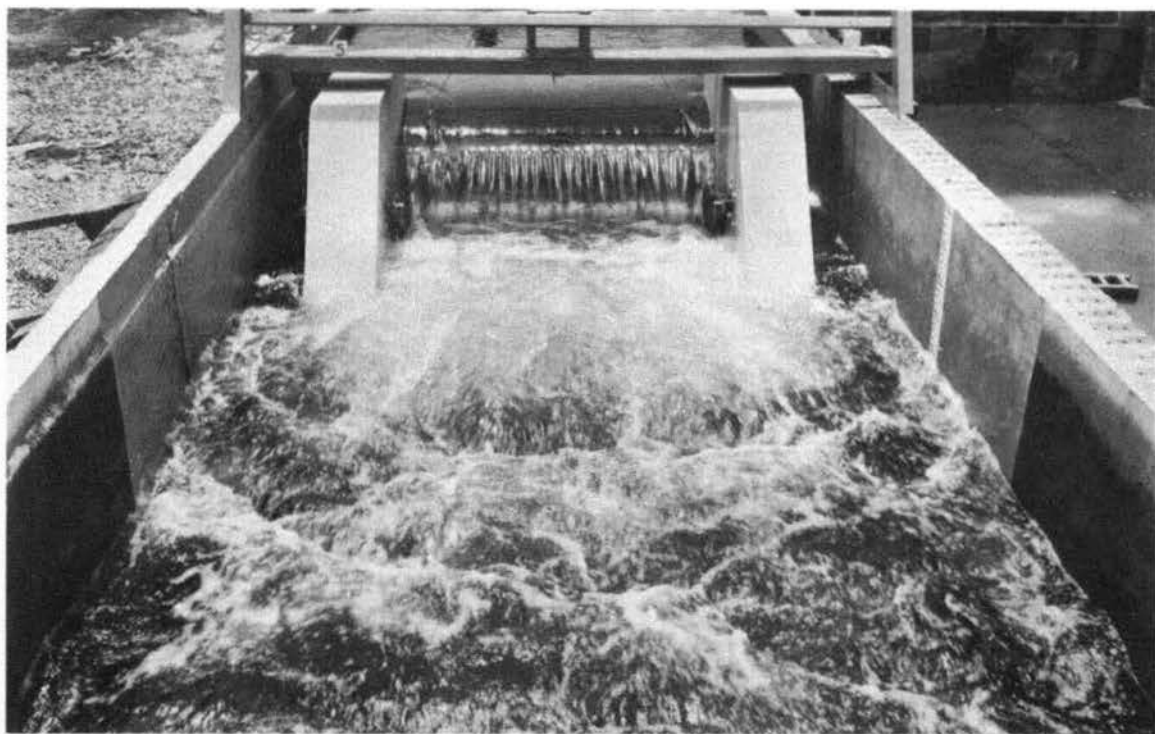

Fig. 10. Flow conditions with 1:10-scale plan 2, alternate E gate installed. Crest at elevation 377.0. Discharge, 6,000 cfs.  
Elevations of: pool, 385.0; tailwater, 368.0

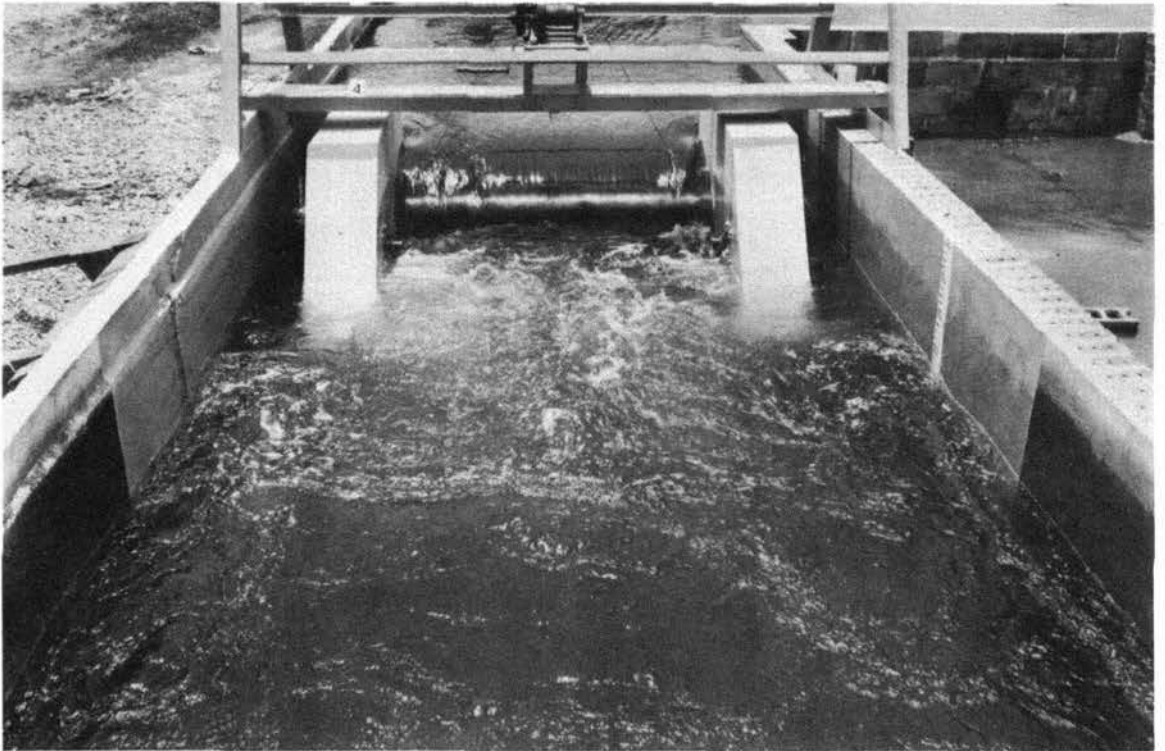

Fig. 11. Flow conditions with 1:10-scale plan 2, alternate E gate installed. Crest at elevation 374.0. Discharge, 8,740 cfs.  
Elevations of: pool, 385.0; tailwater 374.0

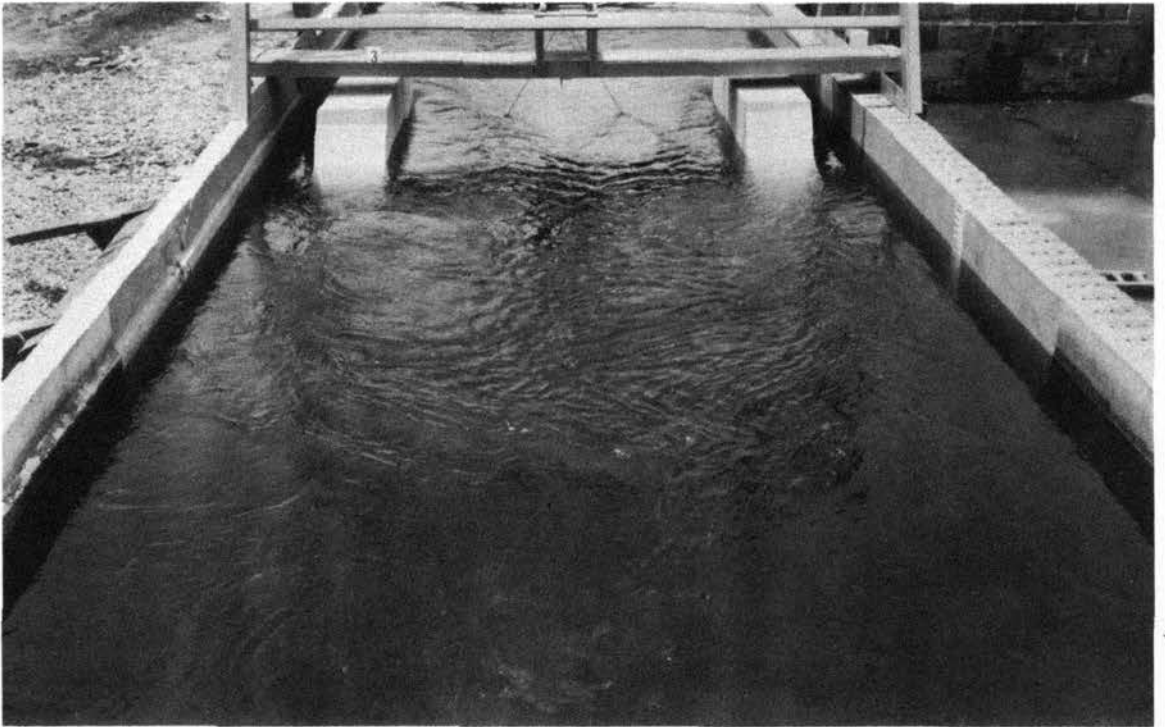

Fig. 12. Flow conditions with 1:10-scale plan 2, alternate E gate installed. Crest at elevation 359.0. Discharge, 14,000 cfs.  
Elevations of: pool, 385.0; tailwater 384.6

entirely closed revealed that this alteration had no effect on hydraulic performance (plate 18 and table 13). Investigation of the effect of drain holes in the bottom of the gate to permit the rise and fall of water in the gate as the tailwater elevation varied revealed that best gate performance was achieved with 20 drain holes each 0.667 ft in diameter (plate 19).

#### Effect of seal friction

25. A force of 20 kips for seal friction, estimated by the Nashville District Office, was reproduced on the model by means of a section of rubber seal placed on the upstream skin plate. The addition of seals to the gate did not affect hydraulic performance of the gate. The magnitude of forces acting on the gate was increased about 20 kips throughout its course of travel (plate 20 and table 14).

#### Air demand

26. Air demand requirements of the vents in the crest of the gate were determined with the pool maintained at elevation 385 and the tailwater elevations adjusted in accordance with the data shown on plate 22. Details of the air vent on the trunnion arms, together with air demand requirements for one vent, are shown on fig. 7 (page 6) and plate 21. It is to be noted that air demand was greatest as the gate crest was varied from elevation 381 to 383. No air was required below a gate elevation of 375. All measurements were made with a velometer (paragraph 9) installed at the air vent entrance as shown in fig. 7.

#### Silting and erosion tests

27. Although a submergible-type tainter gate design had been developed that was satisfactory hydraulically, some concern was felt that with the gate in the lowered position bed material being transported by the flow might become lodged around the gate, causing it to become inoperative. To investigate this possibility one cubic yard of gravel was shoveled into the model upstream from the gate over a period of one hour (all dimensions are model). In prototype dimensions some of the gravel pieces were 6 in. in size. With the gate at elevation 359 (same elevation as sill) gravel was trapped between the gate and the sill in such amounts that no movement in either direction

(raising or lowering) could be accomplished (fig. 13). A force of 750 kips was exerted on the hoist without dislodging the gate. Some of the gravel also was deposited on the downstream face of the gate. With the gate raised to elevation 361.8, thus eliminating the depression between the sill and the gate crest, only a small amount of material was deposited upstream from the gate (fig. 14). A force of 450 kips was required to raise the gate; also the gate could not be lowered until it had been raised to elevation 384 and the trapped debris flushed out by flow over and around the gate. These silting tests were probably more severe than the conditions that would be encountered in normal prototype operations.

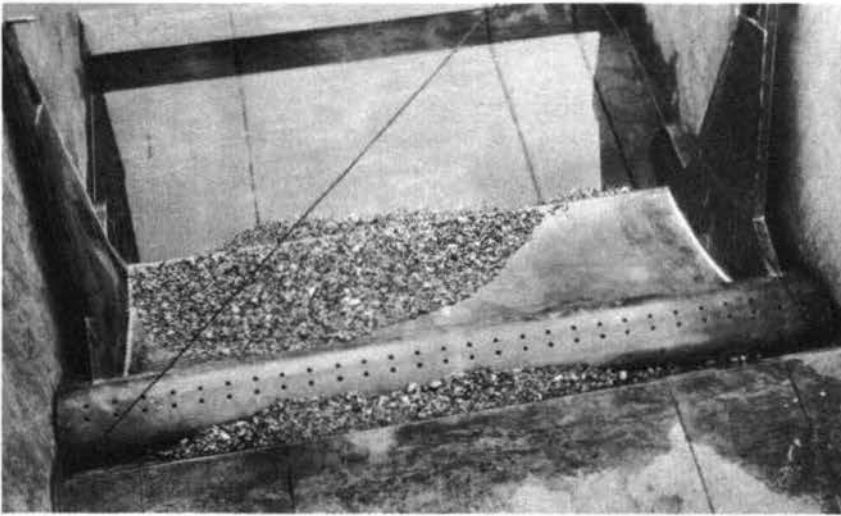
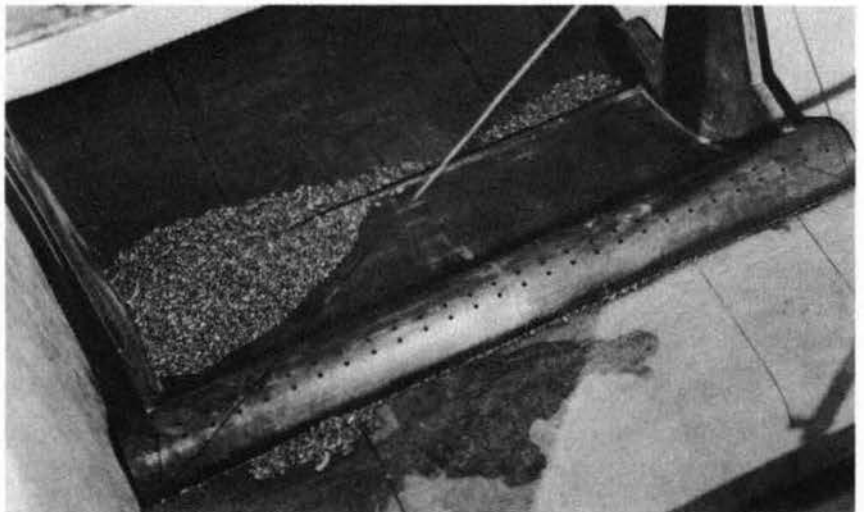

Fig. 13. Downstream view of plan 2, alternate E gate, crest at elevation 359.0, at end of silting tests.

Discharge,  
14,000 cfs.  
Elevations of:  
pool, 385.0,  
tailwater,  
384.6

Fig. 14. Downstream view of plan 2, alternate E gate, crest at elevation 361.8, at end of gravel silting tests. Discharge, 13,600 cfs. Elevations of: pool, 385.0, tailwater, 383.8



28. To study the possibility of debris downstream of the end sill being brought upstream and deposited within the stilling basin by basin action, the bed of the exit area was molded in gravel and erosion tests were conducted. Scour tests at discharges of 8,740 and 14,000 cfs (figs. 15 and 16) revealed no upstream movement of material. These tests were conducted with the original design stilling basin (plate 4) in place.

Fig. 15.  
Upstream view of plan  
2, alternate E gate,  
crest elevation 374.0,  
at end of scour tests.  
Discharge,  
8,740 cfs.  
Elevations of:  
pool, 385.0,  
tailwater, 374.0

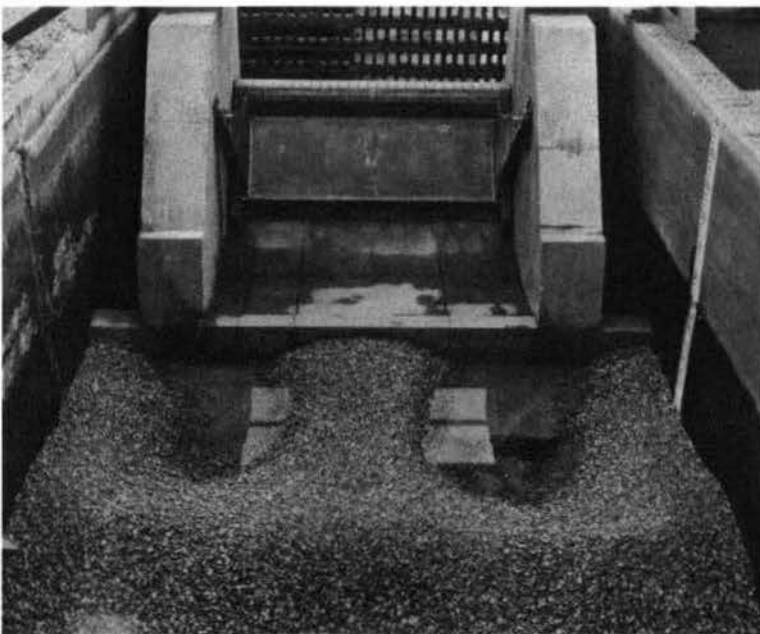
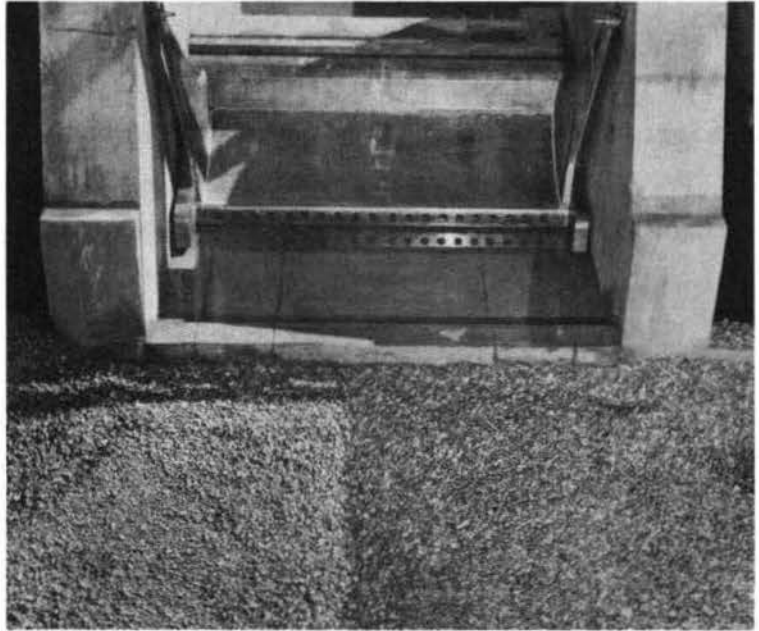

Fig. 16.  
Upstream view of plan  
2, alternate E gate,  
crest elevation 359.0,  
at end of scour tests.  
Discharge,  
14,000 cfs.  
Elevations of:  
pool, 385.0,  
tailwater, 384.6

### Spillway Rating

29. Spillway rating data for the plan 2, alternate-E gate, with the tailwater varied in accordance with information furnished by the Nashville District Office, are shown on plates 22-24. These data were obtained on the 1:36-scale model.

30. Consideration also was given to the possibility of raising the sill from elevation 359 to 362 or 365. Discharge data obtained on both the 1:36- and 1:10-scale models with all gates opened full and high pool elevations are shown on plate 25. These data indicate that the amount of swell head was increased slightly as the sill elevation was raised. It was decided to maintain the sill at its original elevation of 359.

### Tests of Plan 3 Gate

31. Further consideration of the gate-operating machinery by the

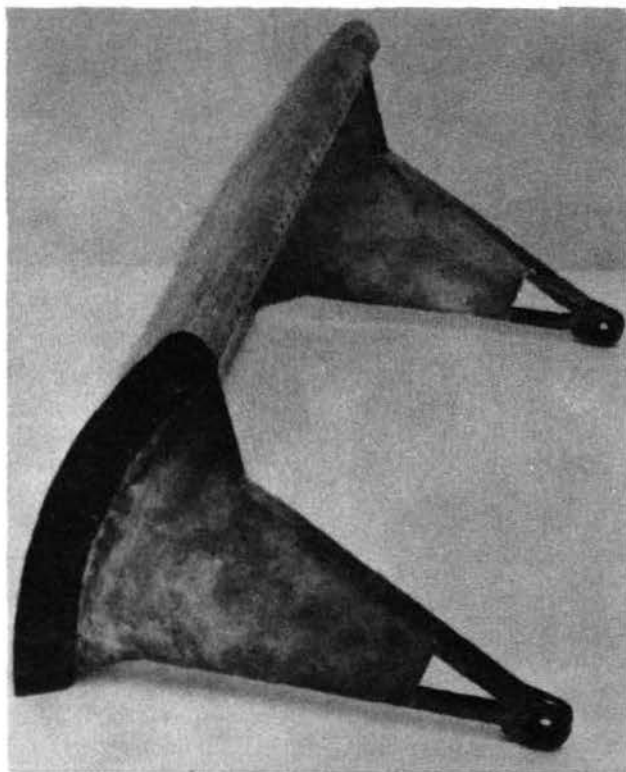

Fig. 17. 1:36-scale model  
of plan 3 gate

Nashville District led to the abandonment of the rack and pinion scheme of operation. Instead, hoisting cables passing over sprockets near the top of the gate were selected. This alteration eliminated the need for pinion guards and resulted in a simpler type gate (fig. 17). The changes effected in the plan 3 gate and piers are shown on plate 26. Weight of the plan 3 gate was 111 tons.

32. Forces required to hold the plan 3 gate at a particular opening are shown on plate 27 and on table 15. The maximum force required to raise the gate

was about 315 kips; no uplift forces were encountered. Thus the criteria for satisfactory gate performance (paragraph 16) were satisfied.

#### Final Design Gate

33. Although a gate design had been developed that satisfied hydraulic requirements, the Nashville District decided to incorporate a partially submergible-type gate in the final plans. This gate would have a maximum submergence of about 7 ft below normal upper pool (elevation 385) and would then be raised for passage of flow under the gate. The trunnion arm was increased in length from 32 to 38.5 ft and the trunnion setting was raised from elevation 375 to 391. No final details of the gate were furnished the Waterways Experiment Station nor were any tests of gate performance conducted.

#### Stilling Basin Tests, Final Design Gate

34. Tests were conducted on the 1:36-scale model to determine the proper position and height of end sill for satisfactory stilling of flow over and under the semisubmergible gate. In the interests of economy, and because of the necessity for quick completion of the contract drawings, the plan 2 gate was used for these tests with the sill and trunnion locations altered as shown on plate 28 to simulate the proper angle of flow under the gate.

35. An initial series of observation tests was conducted to determine the most critical discharge condition for flow over or under the gates. These tests quickly indicated that basin performance was more critical for flow under the gates, and that a discharge of about 7,150 cfs per gate or a total flow of 50,000 cfs through all seven gates seemed to provide the most critical condition. Accordingly, scour and velocity tests were conducted for a discharge of 50,000 cfs (bottom of gate at elev 363.4) and sill heights of 3, 6, and 9 ft. The apron length also was varied from 59 to 74 ft.

36. Stilling basin performance was not entirely satisfactory for a

discharge of 50,000 cfs. The wide control sill resulted in high velocities along the water surface which continued undiminished through the stilling basin. Best basin performance was obtained with either a 6-ft-high end sill and a 69-ft-long apron or a 9-ft-high end sill and a 64-ft-long apron. Flow profiles, velocity and scour measurements are shown on plates 29-34. Although velocities (plate 31) were about the same for either condition listed above, scour measurements with the 9-ft-high end sill and the 64-ft-long apron were superior to those recorded with the 6-ft-high end sill located on the 69-ft-long apron.

## PART IV: DISCUSSION OF RESULTS

37. Model tests of the original design submergible-type tainter gate revealed undesirable gate performance. Uplift forces of 250 kips, downpull forces of 650 kips, and the tendency for the gate to oscillate when subjected to flow sufficed to eliminate the original design gate from further consideration. However, after considerable investigation, several types of gates were developed that met the design criteria that uplift forces should be eliminated, downpull forces should not exceed 300 kips, and the gate should be stable under all conditions of head. These gates have been designated plans 2 and 3 in this report. The principal revision of the original gate that did most to satisfy design criteria was the aeration of the nappe at the gate crest. This was accomplished by lines of vents across the top of the gate. Air was transmitted to the vents by passages in the trunnion arms and offsets in the adjacent pier faces. Another item of concern was the minimizing of the gate area presenting an obstruction to flow when the gate was in a lowered position. This revision reduced downpull forces.

38. One alteration of the plan 2 gate, designated plan 2 alternate E, was investigated on a 1:10-scale model to insure that the results obtained on the 1:36-scale model were accurate. Results of tests indicated identical performance, verifying previous indications that the gate can be expected to perform satisfactorily under prototype conditions.

39. The possibility of bed material being trapped on or around the gate thus preventing or hindering movement of the gate is a problem not susceptible of ready solution on a narrow section model. It is believed, however, that the silting tests conducted on the model were more severe than any comparable conditions that would be encountered in the prototype. Therefore, the use of a submergible-type tainter gate for control of flow through navigation dams is believed feasible from this standpoint. This is especially true if the curved portion of the gate crest is maintained at an elevation several feet above the sill to reduce the area between the gate and the sill to a minimum. However, in order to verify the results of these silting tests it is recommended that a

single submergible-type tainter gate be installed in a prototype structure for further investigation. Possible economies to be effected by use of a submergible-type gate are sufficient to warrant further investigation.

40. Although a submergible-type tainter gate that resulted in good hydraulic performance had been developed from the model tests, a decision was made to use a semisubmergible-type gate at Cheatham Dam. A maximum head of 7 ft is to be passed over this gate after which it is to be raised for passage of flow under the gate. This type gate was not tested in the model nor were final details available for presentation herein.

41. Emphasis was given on the Cheatham model to the development of a gate design that would satisfy hydraulic requirements; however, prior to completion of the study a few tests were conducted on a schematic reproduction of the plan 2 gate to study stilling-basin conditions with flow over and under the proposed semisubmergible-type gate. Basin conditions were found to be most critical for a discharge of about 7150 cfs under each gate. On the basis of the few tests conducted of basin performance it is recommended that a stilling basin at elevation 345 with a 9-ft-high end sill located 64 ft downstream from the control sill be constructed in the prototype.

Table 1

PRESSURES ON ORIGINAL DESIGN (PLAN 1) GATE WITH GATE LOWERED 7 FT

Pool Elev 385.0

Gate Crest Elev 378.0

<u>Piezometer Number</u>	<u>Piezometer Zero</u>	<u>Tailwater Elev 378</u>	<u>Tailwater Elev 371</u>	<u>Tailwater Elev 364</u>	<u>Tailwater Elev 357</u>
1	377.7	-1.2	-2.2	-2.2	-2.2
2	378.0	-3.5	-4.5	-4.5	-4.5
3	377.7	-2.2	-2.9	-2.7	-2.5
4	377.1	-1.3	-1.9	-1.9	-1.9
5	376.4	-0.4	-0.8	-0.8	-0.9
6	375.6	0.6	-0.3	-0.3	-0.4
7	374.8	1.0	-0.3	-0.4	-0.4
8	373.9	1.9	-0.7	-0.7	-0.7
9	373.0	2.2	-1.3	-1.3	-1.5
10	372.0	4.0	-0.2	-0.3	-0.5
11	368.9	8.6	2.6	1.8	1.6
12	364.8	12.9	6.2	2.0	1.7
13	360.6	16.1	7.2	0.2	4.1
14	357.9	20.6	12.6	4.6	2.4
15	355.4	23.1	15.1	7.1	0.6
16	352.8	25.7	17.9	10.4	3.7
17	355.9	22.6	14.4	6.1	0.9
18	359.2	25.6	25.0	24.3	23.5
19	362.8	22.2	22.4	22.2	22.3
20	366.5	18.5	18.9	18.8	18.8
21	370.5	14.5	14.7	14.7	14.7
22	374.3	9.5	10.7	10.5	10.6

Notes: Pressures are recorded in prototype feet of water.  
Tailwater elevations are recorded in feet above mean sea level.  
Locations of piezometers are shown on plate 8.

Table 2

PRESSURES ON ORIGINAL DESIGN (PLAN 1) GATE WITH GATE LOWERED 14 FT

Pool Elev 385.0

Gate Crest Elev 371.0

<u>Piezometer Number</u>	<u>Piezometer Zero</u>	<u>Tailwater Elev 378</u>	<u>Tailwater Elev 371</u>	<u>Tailwater Elev 364</u>	<u>Tailwater Elev 357</u>
1	370.5	-4.5	-10.0	-10.0	-9.0
2	371.0	-10.0	-17.0	-18.0	-17.0
3	371.0	-4.0	-12.0	-12.0	-11.5
4	370.6	-0.6	-8.4	-9.8	-8.6
5	370.1	1.9	-5.5	-6.1	-5.6
6	369.5	3.5	-4.1	-4.8	-4.5
7	368.9	5.1	-3.5	-4.2	-3.9
8	368.2	6.3	-2.9	-3.9	-3.7
9	367.5	7.5	-2.7	-4.3	-3.0
10	366.6	8.9	-0.4	-2.9	-2.1
11	363.9	11.6	5.1	2.4	2.1
12	360.4	15.1	9.1	4.6	3.1
13	356.8	18.7	13.2	4.2	9.7
14	354.3	21.7	18.7	12.2	8.2
15	351.6	24.4	20.9	13.4	8.9
16	348.2	21.8	23.8	17.3	14.3
17	350.6	25.4	21.4	14.4	11.4
18	353.3	22.7	18.2	10.7	6.7
19	356.5	19.5	14.5	6.0	1.5
20	359.8	23.7	23.2	23.4	23.4
21	363.4	20.4	19.9	20.1	20.1
22	376.2	16.3	15.8	16.8	16.6

---

Notes: Pressures are recorded in prototype feet of water.  
Tailwater elevations are recorded in feet above mean sea level.  
Locations of piezometers are shown on plate 8.

Table 3

PRESSURES ON ORIGINAL DESIGN (PLAN 1) GATE WITH GATE LOWERED 21 FT

Pool Elev 385.0

Gate Crest Elev 364.0

<u>Piezometer Number</u>	<u>Piezometer Zero</u>	<u>Tailwater Elev 378</u>	<u>Tailwater Elev 371</u>	<u>Tailwater Elev 364</u>	<u>Tailwater Elev 357</u>
1	363.1	10.9	6.9	7.9	8.4
2	363.9	4.1	-2.4	-2.4	-2.4
3	364.0	3.0	-4.0	-4.5	-4.5
4	363.9	4.6	-3.4	-3.9	-3.9
5	363.7	6.3	-2.2	-2.7	-3.2
6	363.4	7.6	-1.4	-1.9	-1.9
7	363.0	9.0	-0.5	-1.5	-1.8
8	362.5	10.5	0.0	-1.0	-1.3
9	362.0	12.0	0.2	-1.5	-1.5
10	361.4	12.6	2.1	1.1	0.6
11	359.3	15.7	7.7	6.2	5.7
12	356.5	18.5	12.0	9.0	8.5
13	353.8	21.2	15.2	11.2	7.7
14	351.7	24.3	19.3	16.8	14.8
15	348.4	26.6	22.6	19.1	12.2
16	344.8	30.2	26.0	22.7	16.2
17	346.3	29.2	24.7	21.2	14.7
18	348.3	27.2	22.7	19.2	12.7
19	350.7	26.3	20.3	16.8	10.3
20	353.5	23.5	17.5	14.5	8.5
21	356.7	20.8	16.3	12.8	6.3
22	360.0	17.7	16.5	17.0	17.0

---

Notes: Pressures are recorded in prototype feet of water.  
Tailwater elevations are recorded in feet above mean sea level.  
Locations of piezometers are shown on plate 8.

Table 4

PRESSURES ON ORIGINAL DESIGN (PLAN 1) GATE WITH GATE LOWERED 26 FT

Pool Elev 385.0

Gate Crest Elev 359.0

<u>Piezometer Number</u>	<u>Piezometer Zero</u>	<u>Tailwater Elev 378</u>	<u>Tailwater Elev 371</u>	<u>Tailwater Elev 364</u>	<u>Tailwater Elev 357</u>
1	357.6	15.9	13.9	13.4	13.4
2	358.6	14.9	12.9	12.4	12.4
3	358.9	14.8	12.6	12.1	12.1
4	359.0	14.3	11.5	11.5	11.5
5	358.9	14.3	10.6	10.6	10.6
6	358.9	14.1	9.9	9.1	9.6
7	358.8	14.2	8.7	8.2	8.2
8	358.5	14.5	8.0	7.0	7.5
9	358.2	14.4	7.3	6.3	6.3
10	357.8	15.2	8.7	7.0	7.2
11	356.2	18.1	11.3	9.6	9.8
12	354.3	21.0	14.2	11.2	11.2
13	352.3	23.7	16.3	10.7	11.2
14	350.5	25.7	20.5	16.5	17.5
15	347.8	28.4	23.2	18.7	19.7
16	343.3	32.9	27.7	24.7	24.9
17	344.1	32.0	27.4	23.9	24.1
18	345.4	31.0	26.1	22.6	22.8
19	347.1	29.3	24.4	20.9	21.1
20	349.3	27.1	22.2	18.7	18.9
21	352.0	24.3	19.5	16.0	16.2
22	354.9	21.1	16.6	13.1	13.9

---

Notes: Pressures are recorded in prototype feet of water.  
Tailwater elevations are recorded in feet above mean sea level.  
Locations of piezometers are shown on plate 8.

Table 5

RESULTS OF TESTS OF ALTERNATE PLAN 1 GATES

Al- ter- nate	Description	Max Down- pull kips	Conditions for Max Downpull		Max Up- lift kips	Conditions for Max Uplift	
			Gate Elev	Tail- water Elev		Gate Elev	Tail- water Elev
A	328.5 tons added to original plan 1 gate in the form of lead weights between the girders	<u>1080</u>	383	355	None		
B	27-ton tail added to bottom of plan 1 gate (gate oscillated below gate crest elev 377)	<u>840</u>	381	350	<u>300</u>	367	373
C	Trunnion of alternate B gate moved up 0.8 ft to elev 375.8, leaving an opening of 1.094 ft between spillway and gates	<u>770</u>	385	350	<u>335</u>	367	377
D	Plan 1 gate was installed at trunnion elev 375.8	<u>725</u>	381	350	<u>305</u>	369	377
E	Plan 1 gate drain holes (8) in lower skin plate were increased in diameter from 1 ft to 2 ft (gate oscillated between gate crest elev 381-383)	<u>395</u>	381	355	<u>265</u>	367	373
F	Girders on plan 1 gate and alternates A thru E were replaced with trusses (91 tons)	<u>400</u>	379	355	<u>240</u>	367	373
G	Plan 1 gate with skin plate below lowest truss removed (84 tons)	<u>305</u>	359	355	<u>265</u>	367	367
H	Crest extension added to plan 1 gate increasing weight to 118 tons	<u>725</u>	379	355	<u>50</u>	367	373

(Continued)

Table 5 (Continued)

Al- ter- nate	Description	Max Down- pull kips	Conditions for		Max Up- lift kips	Conditions for	
			Max Downpull Gate Elev	Tail- water Elev		Max Uplift Gate Elev	Tail- water Elev
I	Tubular air vents, 0.5 ft in diameter, placed at first and third quarter-width points 3 ft below crest on downstream skin plate of alternate H gate (123 T)	<u>675</u>	379	355	<u>70</u>	363	375
J	Alternate I gate with new trunnion elev 370; sill crest raised to elev 364 and spillway bucket to elev 337.5	<u>525</u>	379	355	<u>140</u>	363	369
K	Alternate I gate with trunnion elev 385.0 and false sill fitted to sill (89 T)	<u>655</u>	381	355	<u>80</u>	369	377
L	Alternate I gate with revised false sill	<u>660</u>	381	355	<u>75</u>	369	377
M	Alternate I gate with skin plate removed below lower truss (85 T)	<u>440</u>	363	355	<u>75</u>	369	381
N	The downstream face of plan 1 gate redesigned with exponential curve of form $X^{1.85} = 2H_c^{0.85}Y$ , where $H_c = 12$ ft (98 T)	<u>700</u>	361	355	<u>50</u>	367	381
O	Using alternate N shape, the under downstream skin plate of plan 1 gate, which was covered, was removed from the crest at the top of the gate to the first beam from the center line of the trunnions. The lower skin plate on the bottom of the gate was again used, and 8 1-ft-diameter drains were installed.	<u>655</u>	361	355	None, 0 on force meter at gate elev 367 and TW elev 381		

(Continued)

Table 5 (Continued)

Al- ter- nate	Description	Max Down- pull kips	Conditions for		Conditions for	
			Max Downpull Gate Elev	Tail- water Elev	Max Up- lift kips	Max Uplift Gate Elev
P	The downstream skin plate of plan 1 gate was removed from top to the first beam below the trunnion and replaced with exponential curve $X^{1.85} = 2H_c^{0.85}Y$ , where $H_c = 14$ ft (100 T)	<u>700</u>	361	355	None, 0 on force meter at gate elev 367 and TW elev 381	
Q	Alternate P gate was fitted with end shields and the 8 1-ft drain holes were increased to 16 2-ft-diameter drains (104 T)	<u>650</u>	361	355	None, 0 on force meter at gate elev 367 and TW elev 381	
R	Alternate Q end shields converted to air vents (108 T). There were 16 2-ft-diameter drains	<u>700</u>	361	355	None, 0 on force meter at gate elev 369 and TW elev 381	
S	The downstream skin plate of alternate R gate was extended into the 4.25-ft radius on bottom of gate (101 T)	<u>470</u>	367	355	None	
T	The downstream shape of alternate R gate was revised to include a 32-ft radius between the upper and lower extremes of the alternate S gate. 18 additional 1-ft-diameter drains were placed below the existing 16 2-ft-diameter drains (112 T)	260	381	355	<u>190</u>	369      377

(Continued)

Table 5 (Continued)

Al- ter- nate	Description	Max Down- pull kips	Conditions for Max Downpull		Max Up- lift kips	Conditions for Max Uplift	
			Gate Elev	Tail- water Elev		Gate Elev	Tail- water Elev
U	Alternate R gate was revised to add 18 1-ft-diameter drains below the existing 16 2-ft-diameter drains	<u>315</u>	369	355	None, 0 on force meter at gate elev 367 and TW elev 381		
V	The downstream upper skin plate of the alternate U gate was extended to the bottom skin plate by means of a 12-ft radius (123 T)	<u>505</u>	377	355	None, 0 on force meter at gate elev 367 and TW elev 381		
W	The downstream skin plate of the alternate V gate was removed below the break in alignment	<u>640</u>	363	355	<u>45</u>	369	377

Notes: Pool elevation was 385 for all tests.

Underscored values are forces that exceeded the proposed tentative design criteria.

Alternate U came nearest criteria of 300 kips downpull force and no uplift.

Table 6

PRESSURES ON REVISED DESIGN (PLAN 2) GATE WITH GATE LOWERED 7 FT

Pool Elev 385.0

Gate Crest Elev 378.0

<u>Piezometer Number</u>	<u>Piezometer Zero</u>	<u>Tailwater Elev 378</u>	<u>Tailwater Elev 371</u>	<u>Tailwater Elev 364</u>	<u>Tailwater Elev 357</u>
1	376.5	7.5	7.5	7.5	7.5
2	377.5	2.0	1.5	1.5	1.5
3	378.0	-0.5	-1.5	-1.5	-1.0
4	377.9	0.6	-0.9	-0.9	-0.9
5	377.6	0.4	-2.1	-1.6	-1.6
6	376.6	1.4	-1.6	-1.1	-0.6
7	374.9	3.1	-0.9	-0.9	-0.9
8	373.4	4.6	-0.9	-0.4	0.1
9	371.4	6.6	0.1	-0.4	0.1
10	369.0	9.0	2.0	-1.0	-1.0
11	367.0	11.0	3.5	-1.0	-1.0
12	360.0	18.0	10.0	4.0	-1.0
13	355.0	23.0*	22.0**	16.0**	3.0
14	353.0	26.0	22.0	16.5*	5.5
15	356.0	23.0	18.5	13.5*	2.0
16	364.0	22.0	22.0	22.0	22.0
17	371.0	15.0	15.0	15.0	15.0
18	375.0	10.5	10.5	10.5	10.5

Notes: Pressures are recorded in prototype feet of water.  
Tailwater elevations are recorded in feet above mean sea level.  
Locations of piezometers are shown on plate 15.

\* Piezometer pressure fluctuated approximately 5 feet.

\*\* Piezometer pressure fluctuated approximately 10 feet.

Table 7

PRESSURES ON REVISED DESIGN (PLAN 2) GATE WITH GATE LOWERED 14 FT

Pool Elev 385.0

Gate Crest Elev 371.0

<u>Piezometer Number</u>	<u>Piezometer Zero</u>	<u>Tailwater Elev 378</u>	<u>Tailwater Elev 371</u>	<u>Tailwater Elev 364</u>	<u>Tailwater Elev 357</u>
1	369.0	14.5	14.0	14.5	14.5
2	370.2	5.3	1.3	2.3	2.3
3	370.9	0.6	-5.9	-4.9	-4.9
4	371.0	2.5	-4.0	-2.5	-2.5
5	371.0	3.0	-5.0	-3.5	-3.5
6	370.3	6.7	-2.3	0.2	0.2
7	368.7	8.8	0.8	0.8	0.8
8	367.2	10.3	2.3	0.8	0.8
9	365.1	12.4	4.4	0.9	0.9
10	362.6	14.9	6.9	1.4	0.9
11	360.7	16.8	8.8	3.3	0.8
12	354.7	22.8	14.8	8.8	5.3
13	350.7	26.8	18.3	12.8	9.3
14	348.9	28.6	24.1	18.1	14.1
15	350.7	26.8	22.8	17.3	12.8
16	351.5	20.5	16.0	10.0	6.0
17	363.8	21.2	21.2	21.2	21.2
18	367.6	17.4	17.4	17.4	17.4

Notes: Pressures are recorded in prototype feet of water.  
Tailwater elevations are recorded in feet above mean sea level.  
Locations of piezometers are shown on plate 15.

Table 8

PRESSURES ON REVISED DESIGN (PLAN 2) GATE WITH GATE LOWERED 21 FT

Pool Elev 385.0

Gate Crest Elev 364.0

<u>Piezometer Number</u>	<u>Piezometer Zero</u>	<u>Tailwater Elev 378</u>	<u>Tailwater Elev 371</u>	<u>Tailwater Elev 364</u>	<u>Tailwater Elev 357</u>
1	361.2	19.3	16.8	16.3*	16.3*
2	362.4	18.6*	18.1*	15.6*	15.6*
3	363.3	14.2	9.2	5.7*	5.7*
4	363.7	11.8	5.3	1.3*	1.3*
5	364.0	10.0	0.0	-6.0*	-6.0*
6	363.7	11.3	-1.7	-10.7**	-10.7**
7	362.4	13.6	4.6	-2.4*	-2.4*
8	360.9	15.1	6.6	0.1*	0.1*
9	358.7	16.8	8.8	1.8*	1.8*
10	356.3	19.7	11.2	4.2*	4.2*
11	354.8	21.2	12.7	5.2*	5.2*
12	350.0	26.0	17.5	15.0*	15.0*
13	347.5	28.5	21.0	23.0*	23.0*
14	345.8	30.2	24.7	23.7*	23.7*
15	346.2	29.8	25.3	25.3*	25.3*
16	351.2	25.3	20.3	19.8*	19.0*
17	356.5	21.5	17.0	16.0*	16.0*
18	360.0	21.0	19.0	18.0*	18.0*

Notes: Pressures are recorded in prototype feet of water.  
Tailwater elevations are recorded in feet above mean sea level.  
Locations of piezometers are shown on plate 15.

\* Piezometer pressure fluctuated approximately 5 feet.

\*\* Piezometer pressure fluctuated approximately 10 feet.

Table 9

PRESSURES ON REVISED DESIGN (PLAN 2) GATE WITH GATE LOWERED 26 FT

Pool Elev 385.0

Gate Crest Elev 359.0

<u>Piezometer Number</u>	<u>Piezometer Zero</u>	<u>Tailwater Elev 378</u>	<u>Tailwater Elev 371</u>	<u>Tailwater Elev 364</u>	<u>Tailwater Elev 357</u>
1	355.7	19.3	15.8	11.3	11.3
2	356.9	18.1	14.6	13.6	13.6
3	357.9	17.1	13.6	13.1	13.1
4	358.4	16.6	14.1	14.6	14.6
5	358.8	16.2	12.2	12.2	12.2
6	358.9	15.6	0.6	-4.4	-4.4
7	358.0	17.0	7.0	2.5	2.5
8	356.5	18.5	10.5	7.5	7.9
9	354.3	21.2	12.2	9.2	9.2
10	352.2	23.2	12.8	10.8	10.8
11	351.0	24.5	14.5	11.5	11.5
12	347.6	27.9	21.4	23.4	23.4
13	346.2	29.3	25.8	23.8	23.8
14	344.7	31.3	26.3	21.3	21.3
15	344.0	32.3	28.5	23.5	23.5
16	347.4	29.1	25.6	20.1	20.1
17	351.6	24.9	21.4	15.4	15.4
18	354.5	21.5	18.0	12.5	12.5

---

Notes: Pressures are recorded in prototype feet of water.  
Tailwater elevations are recorded in feet above mean sea level.  
Locations of piezometers are shown on plate 15.

Table 10

OPERATING FORCES ON REVISED DESIGN (PLAN 2) GATE WITH PINION GUARDS

Pool Elev 385.0

Gate Crest Elev	Forces in kips, with Gate Moving 0.5 ft per minute in Direction Shown											
	Tailwater Elev 384		Tailwater Elev 381		Tailwater Elev 377		Tailwater Elev 373		Tailwater Elev 369		Tailwater Elev 355	
	Raise	Lower	Raise	Lower	Raise	Lower	Raise	Lower	Raise	Lower	Raise	Lower
359	89	65	86	84	140	126	154	145	163	70	159	145
361	107	79	126	103	173	145	201	182	233	126	224	187
363	112	84	107	84	135	107	154	140	182	149	168	145
365	107	84	84	65	84	65	103	89	117	93	103	84
367	103	86	61	51	51	33	47	33	47	-14	79	70
369	112	93	56	37	33	14	19	14	9	-9	37	33
371	126	98	47	33	37	19	28	23	19	0	37	33
373	131	105	61	42	47	33	42	33	51	37	70	61
375	140	107	75	51	70	61	75	51	93	70	93	70
377	140	112	93	75	93	84	107	98	112	121	131	121
379	145	112	126	98	182	107	168	121	159	145	173	154
381	145	112	177	112	252	135	219	159	224	168	210	177
383	159	128	210	145	233	163	229	182	266	196	261	215
385	191	154	191	168	215	182	238	191	247	201	261	210
386	191	163	201	168	219	187	247	201	257	201	266	215

Table 11

OPERATING FORCES ON PLAN 2, ALTERNATE E GATE WITH PINION GUARDS

Pool Elev 385.0

Gate Crest Elev	Forces in kips, with Gate Moving 0.5 ft per minute in Direction Shown											
	Tailwater Elev 385		Tailwater Elev 381		Tailwater Elev 377		Tailwater Elev 373		Tailwater Elev 369		Tailwater Elev 355	
	Raise	Lower	Raise	Lower	Raise	Lower	Raise	Lower	Raise	Lower	Raise	Lower
359	98	79	112	93	154	135	149	149	145	140	149	145
361	112	89	140	112	168	145	201	177	196	182	196	182
363	117	93	121	103	140	121	159	140	168	154	163	149
365	117	93	98	84	107	93	121	107	121	112	112	112
367	112	93	79	65	65	56	75	70	75	70	103	98
369	131	103	75	61	61	47	61	51	56	51	107	84
371	140	107	79	75	61	47	61	56	72	72	69	79
373	145	107	117	107	70	56	75	65	93	79	135	93
375	145	112	103	107	89	70	79	75	112	89	126	107
377	149	117	103	79	117	93	145	117	145	117	149	135
379	159	121	135	112	177	140	149	131	159	135	187	163
381	159	121	177	135	257	196	182	182	187	177	219	187
383	173	131	233	154	317	163	229	182	233	196	266	224
385	191	149	219	163	219	177	233	191	243	196	266	233
386	191	154	205	163	219	177	233	191	243	196	266	219

Table 12

## OPERATING FORCES ON PLAN 2, ALTERNATE E GATE WITH PINION GUARDS

Pool Elev 387.0

Gate Crest Elev	Forces in kips, with Gate Moving 0.5 ft per minute in Direction Shown											
	Tailwater Elev 385		Tailwater Elev 381		Tailwater Elev 377		Tailwater Elev 373		Tailwater Elev 369		Tailwater Elev 355	
	Raise	Lower	Raise	Lower	Raise	Lower	Raise	Lower	Raise	Lower	Raise	Lower
359	93	84	126	117	159	145	154	145	145	140	149	145
361	112	103	149	131	187	163	205	196	205	191	215	196
363	107	98	126	112	145	131	163	149	163	149	177	154
365	103	89	89	75	103	93	112	107	117	103	121	107
367	89	79	61	51	56	47	56	51	51	47	61	47
369	117	107	47	42	37	33	37	28	33	28	84	70
371	126	112	42	37	33	28	33	28	56	51	145	131
373	135	117	42	42	37	33	42	37	108	91	177	135
375	135	117	51	47	56	47	61	50	117	93	177	145
377	140	121	75	61	84	75	89	84	136	93	177	154
379	145	126	107	89	93	90	131	121	135	117	149	126
381	126	103	140	117	182	140	163	135	159	140	182	159
383	149	131	205	149	285	149	187	136	187	173	224	182
385	187	159	280	177	350	191	215	187	233	210	257	215
386	205	187	313	177	373	210	238	205	252	224	275	233

Table 13

EFFECT OF OPEN AND CLOSED GATE ENDS ON OPERATING FORCES  
 PLAN 2, ALTERNATE E GATE WITH PINION GUARDS, 1:10-SCALE MODEL

Pool Elev 385.0

Gate Crest Elev	Forces in kips, Lowering Gate at Rate of 0.5 ft per minute							
	Tailwater Elev 381		Tailwater Elev 377		Tailwater Elev 373		Tailwater Elev 369	
	Ends Open	Ends Closed	Ends Open	Ends Closed	Ends Open	Ends Closed	Ends Open	Ends Closed
359	97	93	*	*	*	*	*	*
361	92	112	143	153	*	*	*	*
363	100	102	102	108	118	118	*	*
365	87	87	80	82	82	87	*	*
367	87	84	73	74	73	74	70	74
369	87	87	70	74	67	70	66	71
371	91	92	74	76	70	74	97	102
373	94	99	81	87	87	88	107	111
375	106	108	101	104	107	113	123	131
377	113	119	123	126	134	121	143	148
379	128	131	132	138	157	161	160	164
381	153	153	205	204	174	181	185	194
383	178	183	194	184	178	181	182	194
385	173	171	178	176	182	181	184	194

\* Drain on 1:10-scale model would not pass flow.

Table 14

EFFECT OF GATE SEAL FRICTION ON OPERATING FORCES  
 PLAN 2, ALTERNATE E GATE WITH PINION GUARDS, 1:10-SCALE MODEL

Crest Elev	Forces in kips, with Gate Moving 0.5 ft per minute in Direction Shown			
	No Pool or Tailwater (Dry)		Pool Elev 385 and Tailwater Elev 384	
	Raising Gate Less Seals	Raising Gate With Seals	Raising Gate Less Seals	Raising Gate With Seals
359	89	100	107	113
361	103	112	114	125
363	103	113	125	132
365	98	126	132	147
367	98	128	140	159
369	112	131	147	161
371	117	147	153	175
373	121	138	158	183
375	126	163	163	180
377	128	166	168	193
379	133	171	174	210
381	126	184	178	207
383	168	189	182	213
385	172	192	189	213
386	158	189	194	214

Table 15

OPERATING FORCES ON REVISED DESIGN PLAN 3 SUBMURGIBLE TAINTER GATE

Pool Elev 382.0

Gate Crest Elev	Forces in kips, with Gate Moving 0.5 ft per minute in Direction Shown									
	Tailwater Elev 382		Tailwater Elev 377		Tailwater Elev 373		Tailwater Elev 369		Tailwater Elev 355	
	Raise	Lower	Raise	Lower	Raise	Lower	Raise	Lower	Raise	Lower
359	89	98	117	98	154	145	121	98	168	107
361	98	93	159	140	201	177	201	177	154	145
363	103	103	145	131	168	145	182	154	107	117
365	112	112	135	117	145	131	154	131	84	149
367	121	121	131	112	131	112	131	117	149	140
369	131	131	140	117	121	112	126	126	154	145
371	135	135	154	126	131	117	149	131	173	154
373	140	140	154	131	145	135	173	145	191	173
375	149	149	159	140	168	149	182	163	215	187
377	159	154	177	149	177	163	177	168	247	229
379	163	154	210	163	215	173	215	229	261	233
381	168	159	229	177	229	182	238	201	279	238
383	187	173	205	182	238	182	243	210	313	219
385	201	187	224	191	243	191	247	210	261	238
386	210	196	238	210	257	205	252	219	275	243
387			261	229	271	224	275	233	303	256

(Continued)

Table 15 (Continued)

Pool Elev 385.0

Gate Crest Elev	Forces in kips, with Gate Moving 0.5 ft per minute in Direction Shown											
	Tailwater Elev 385		Tailwater Elev 381		Tailwater Elev 377		Tailwater Elev 373		Tailwater Elev 369		Tailwater Elev 360	
	Raise	Lower	Raise	Lower	Raise	Lower	Raise	Lower	Raise	Lower	Raise	Lower
359	98	88	107	98	149	130	117	107	126	98	130	98
361	107	102	144	130	177	168	196	186	201	186	182	168
363	112	112	130	116	149	140	154	142	177	168	177	149
365	121	126	126	107	121	112	121	117	140	130	126	117
367	126	121	121	102	102	98	93	89	112	98	126	117
369	135	126	140	126	112	93	126	75	117	107	168	140
371	140	130	154	135	140	112	107	89	177	158	201	168
373	144	130	158	140	149	135	177	154	186	163	210	182
375	149	135	163	140	140	130	177	163	196	173	223	191
377	154	140	163	144	154	150	196	168	205	173	238	205
379	163	142	144	130	142	140	163	140	177	140	223	186
381	168	154	186	144	196	163	223	186	210	196	266	229
383	177	163	243	144	223	186	233	210	242	229	280	247
385	196	172	214	172	233	201	247	205	266	223	303	266
386					242	205	252	214	271	229	312	247

(Continued)

Table 15 (Continued)

Pool Elev 387.0

Gate Crest Elev	Forces in kips, with Gate Moving 0.5 ft per minute in Direction Shown											
	Tailwater Elev 384		Tailwater Elev 381		Tailwater Elev 377		Tailwater Elev 373		Tailwater Elev 369		Tailwater Elev 355	
	Raise	Lower	Raise	Lower	Raise	Lower	Raise	Lower	Raise	Lower	Raise	Lower
359	98	93	130	117	163	140	93	84	107	93	117	98
361	130	126	173	158	210	177	224	205	224	210	219	187
363	117	117	154	144	159	149	177	163	117	168	177	168
365	112	107	117	107	121	112	135	117	131	121	121	117
367	121	117	112	107	93	84	93	89	103	93	131	117
369	135	130	140	130	93	79	79	70	84	75	149	145
371	144	140	158	140	149	98	75	70	177	154	187	163
373	149	140	168	140	163	135	187	163	187	168	210	187
375	154	144	163	144	154	149	191	168	196	173	229	205
377	163	149	168	158	186	163	201	173	205	182	243	215
379	168	154	154	135	186	168	196	177	210	187	261	224
381	158	140	154	126	163	149	154	154	177	168	243	215
383	182	154	201	168	186	159	205	177	224	201	266	233
385	223	182	223	191	233	205	238	201	257	238	299	261
386	233	191	242	196	252	219	266	229	280	257	289	271
387	247	210	257	223	266	223	285	238	303	266	317	275

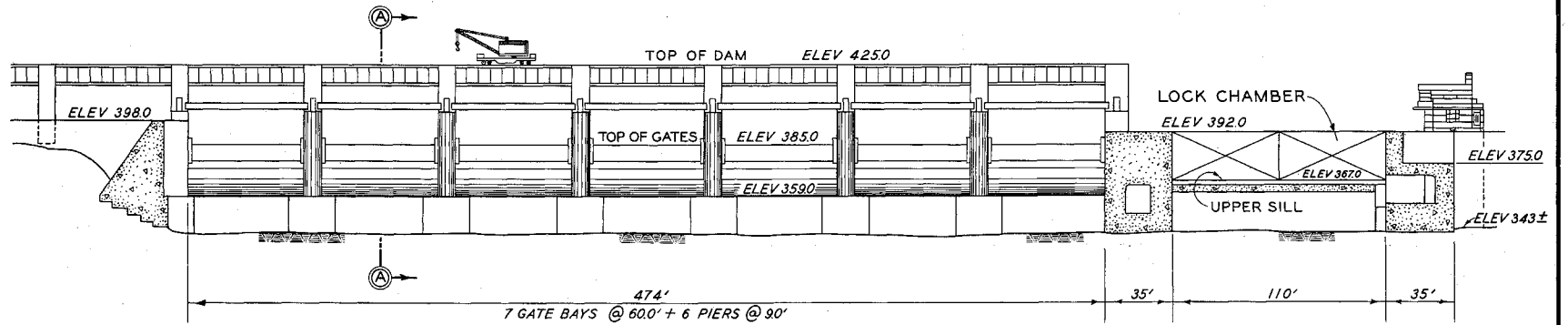

ELEVATION LOOKING DOWNSTREAM

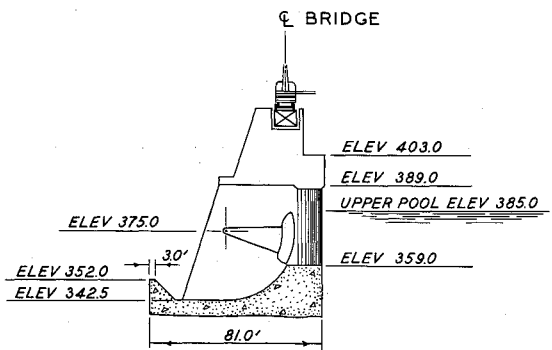

SECTION A-A

CHEATHAM LOCK AND DAM

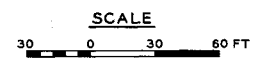

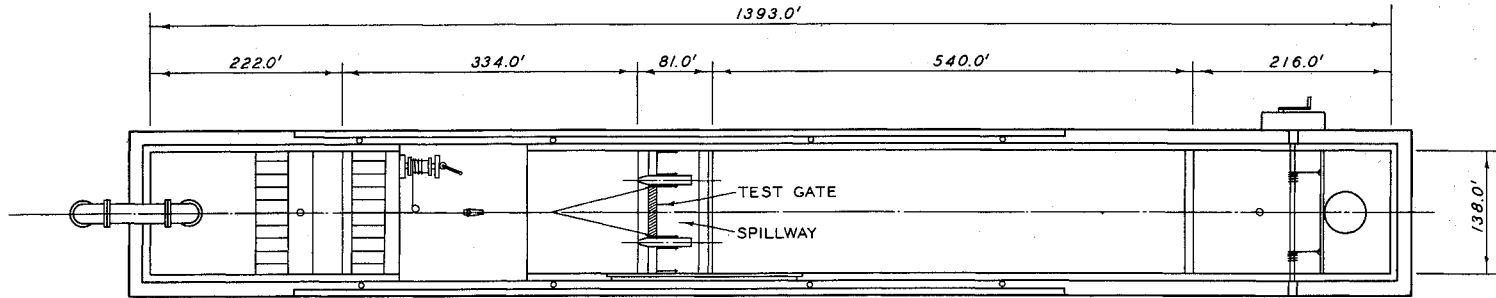

PLAN

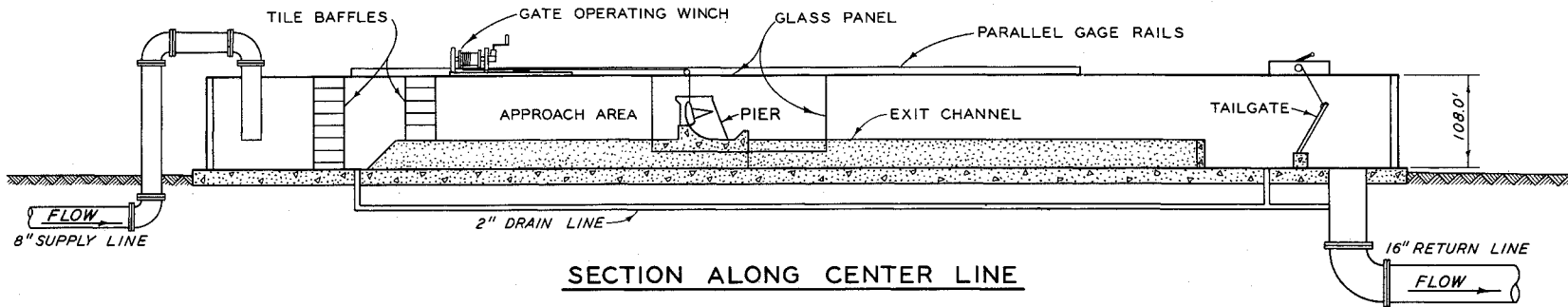

SECTION ALONG CENTER LINE

NOTE: ALL DIMENSIONS ARE IN PROTOTYPE UNITS.

1:36 SCALE

**MODEL LAYOUT**  
ORIGINAL DESIGN (PLAN I)

SCALES

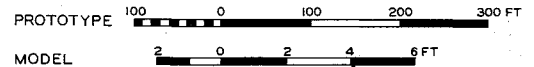

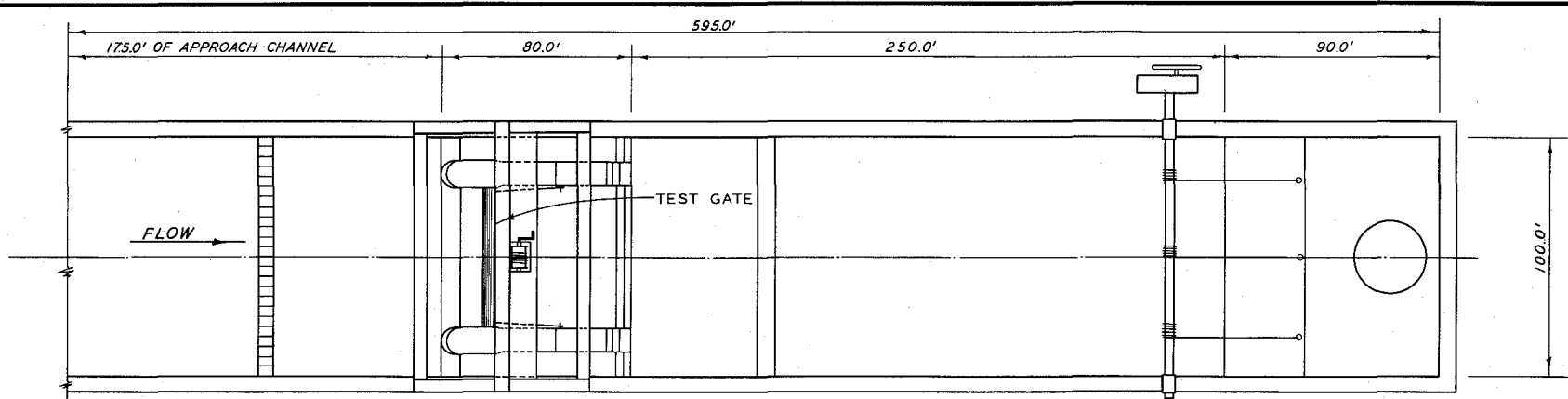

PLAN

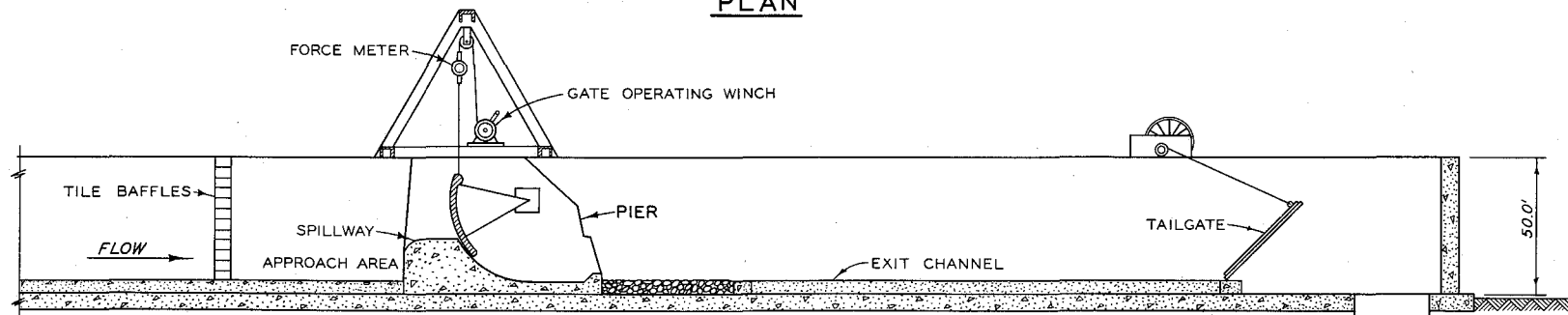

SECTION ALONG CENTER LINE

NOTE: ALL DIMENSIONS ARE IN PROTOTYPE UNITS.

1:10 SCALE

**MODEL LAYOUT**  
**REVISED DESIGN (PLAN 2)**

SCALES





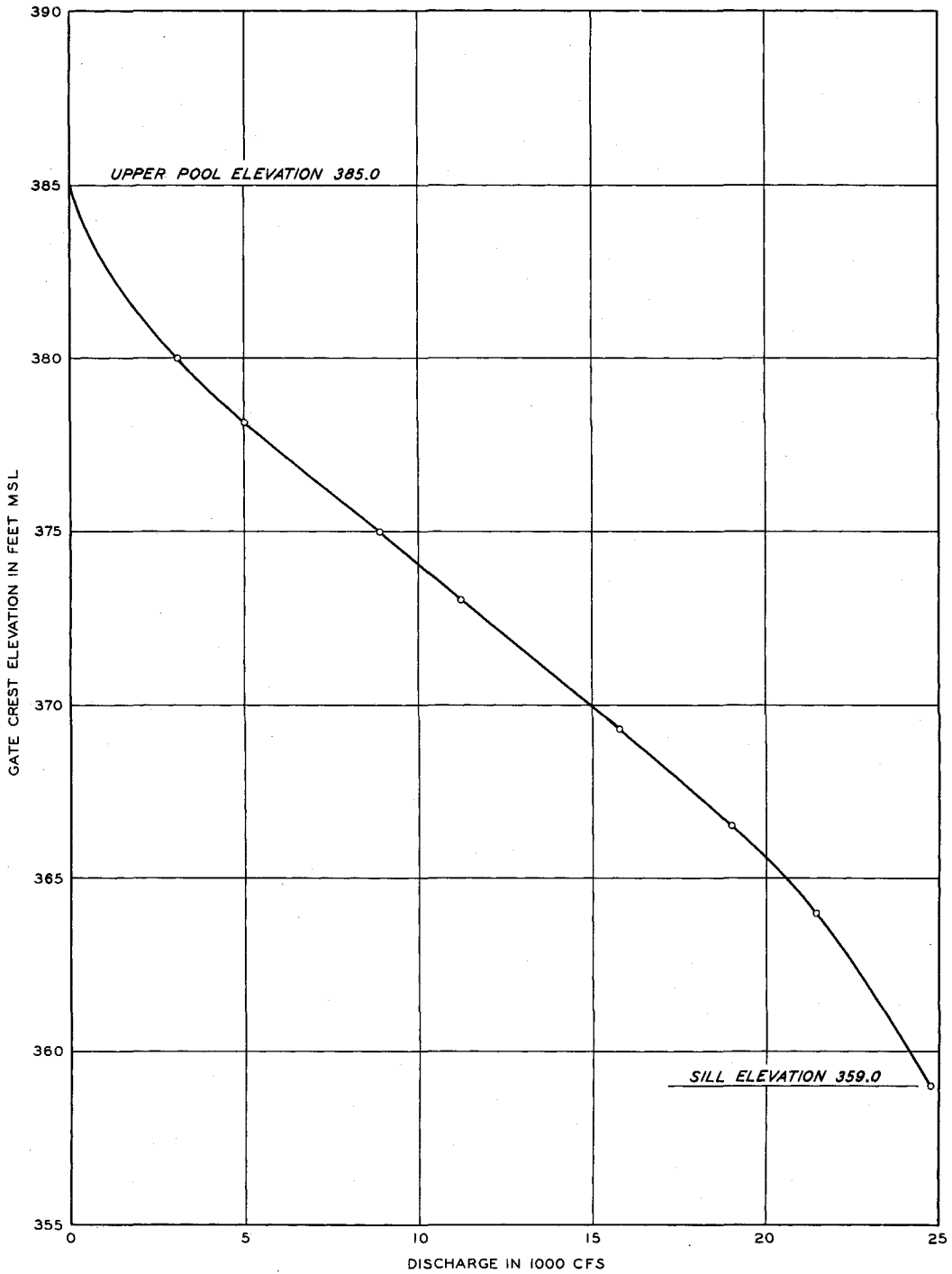

TEST CONDITIONS

POOL ELEVATION 385.0  
 TAILWATER ELEVATION 355.0

**DISCHARGE RATING CURVE**  
 ONE GATE OPERATING  
 ORIGINAL DESIGN (PLAN I) GATE

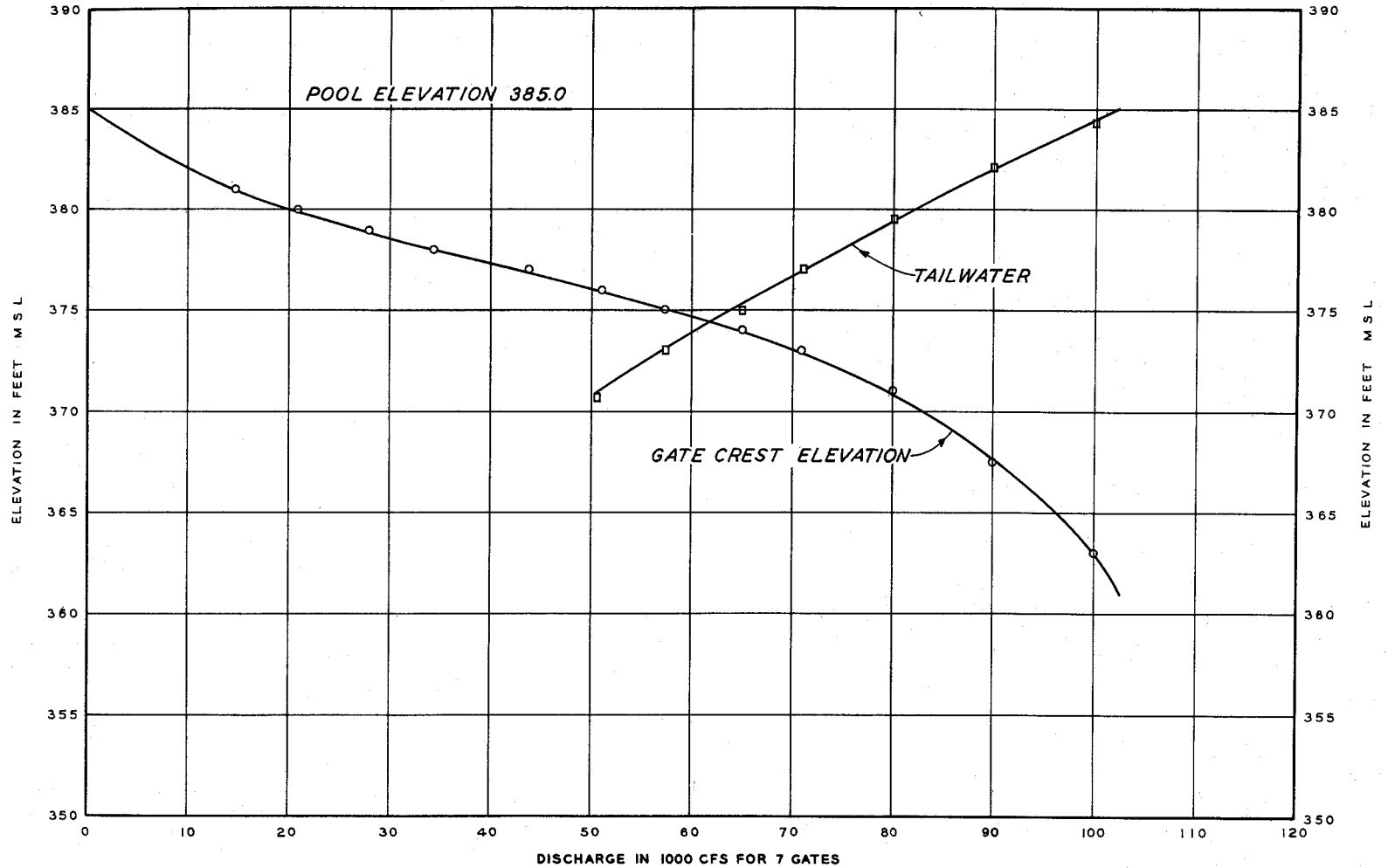

**RATING CURVE**

GATE OPENING VS POOL AND TAILWATER ELEV  
ORIGINAL DESIGN (PLAN 1) GATE

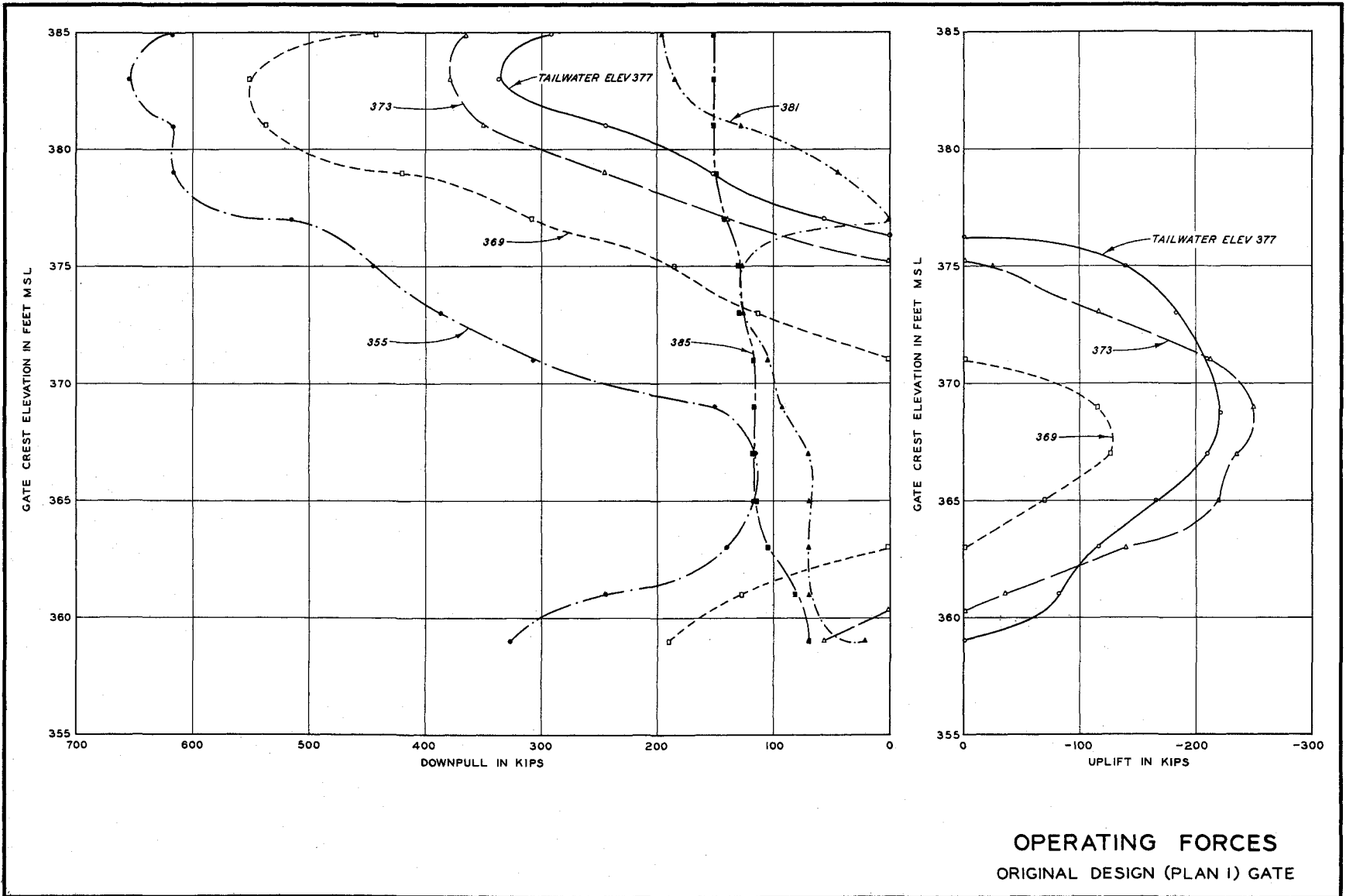

OPERATING FORCES  
ORIGINAL DESIGN (PLAN I) GATE

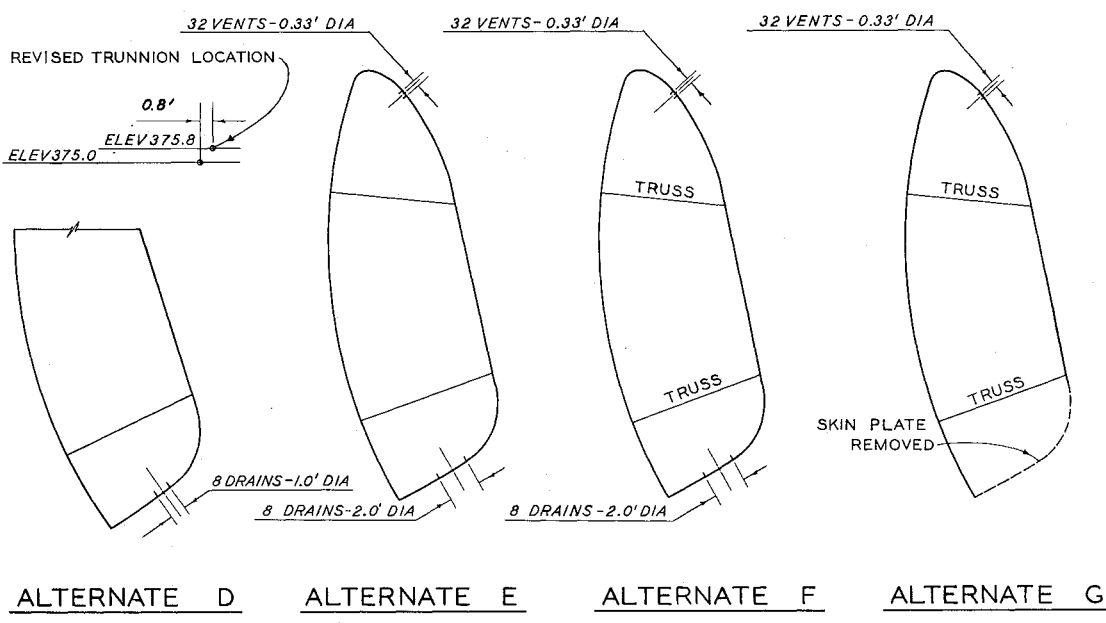
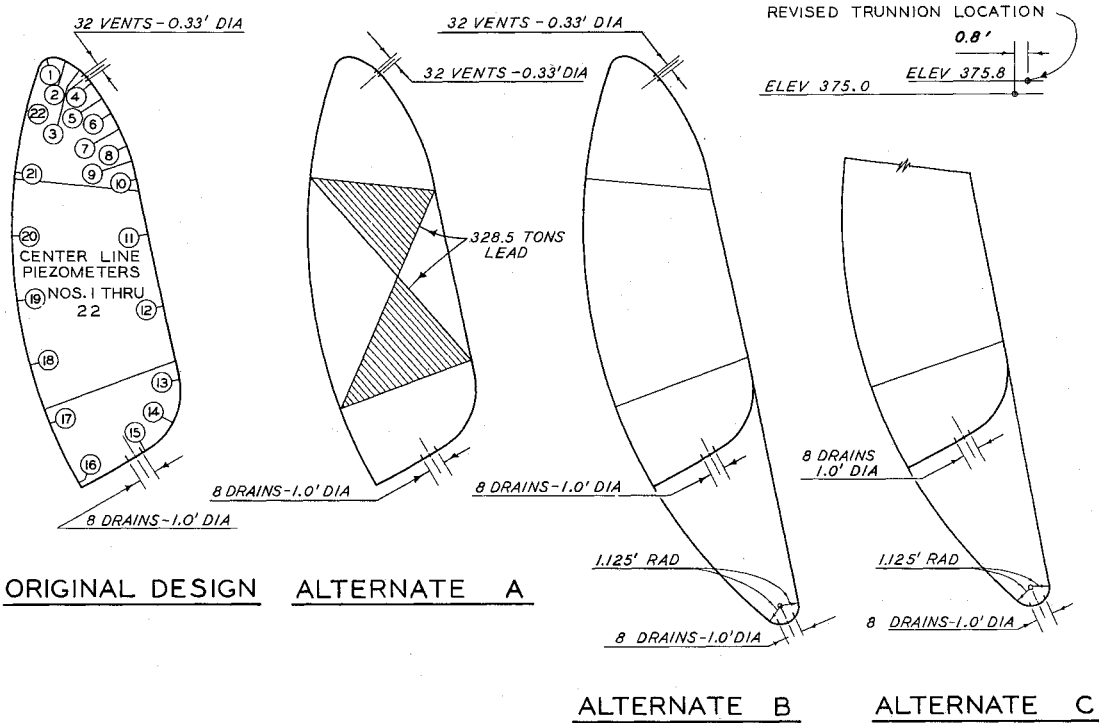

NOTE: ELEVATIONS ARE IN FEET MEAN SEA LEVEL.

**ORIGINAL DESIGN (PLAN I) GATE AND ALTERNATES A-G**

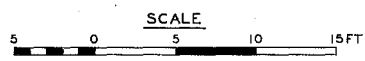

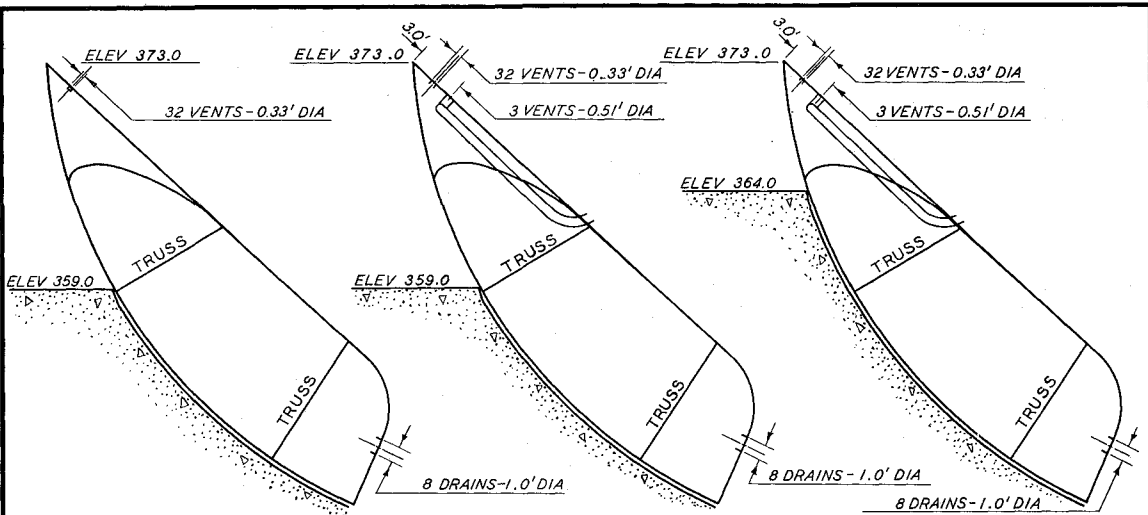

ALTERNATE H

ALTERNATE I

ALTERNATE J

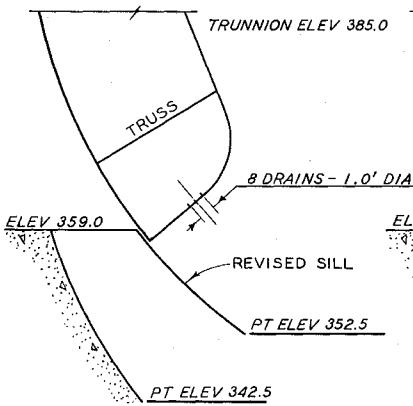

ALTERNATE K

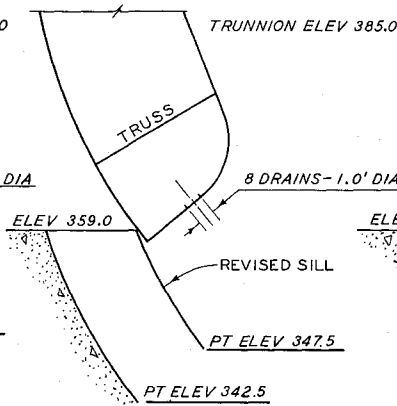

ALTERNATE L

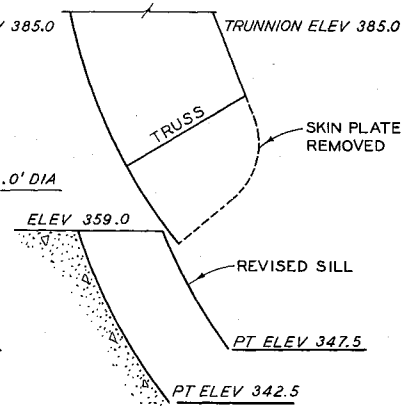

ALTERNATE M

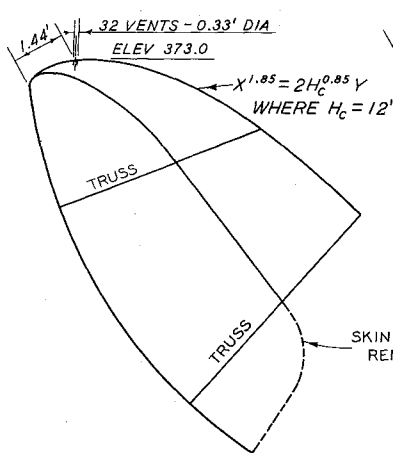

ALTERNATE N

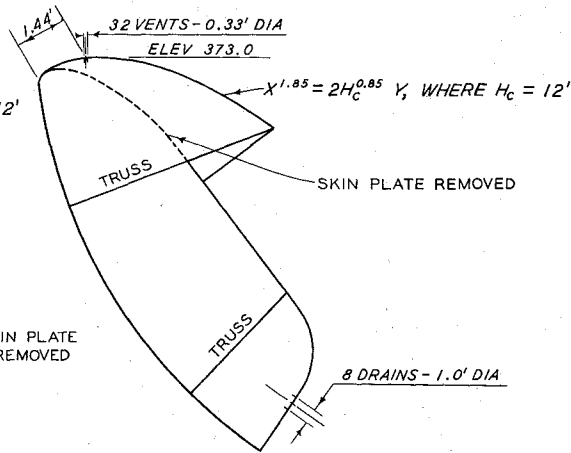

ALTERNATE O

NOTE: ELEVATIONS ARE IN FEET MEAN SEA LEVEL.

ORIGINAL DESIGN (PLAN I) GATE  
ALTERNATES H-O

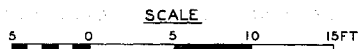

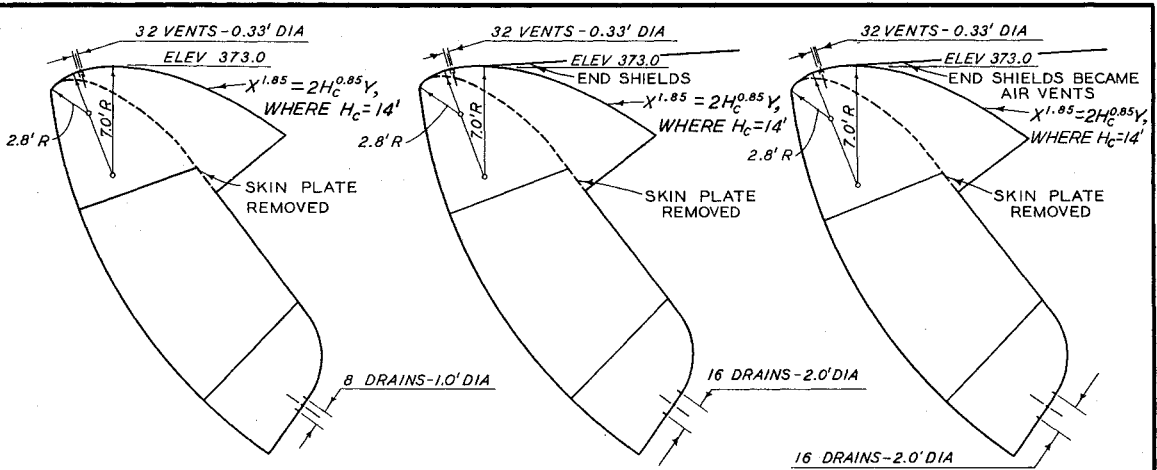

ALTERNATE P

ALTERNATE Q

ALTERNATE R

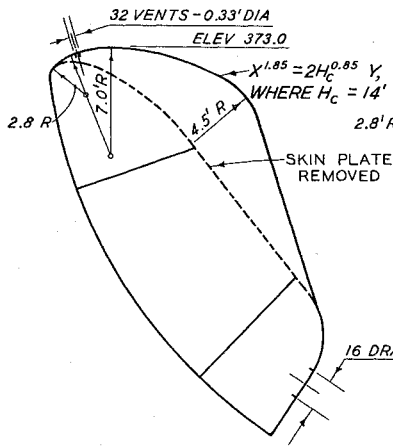

ALTERNATE S

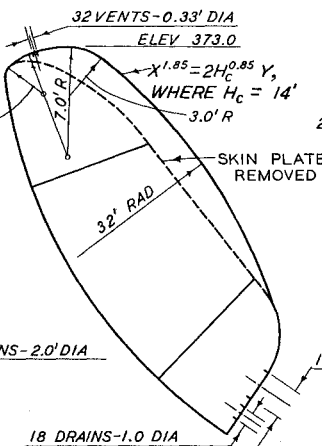

ALTERNATE T

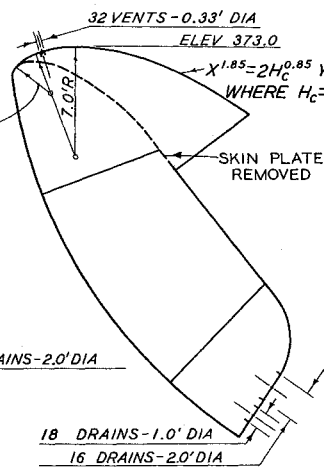

ALTERNATE U

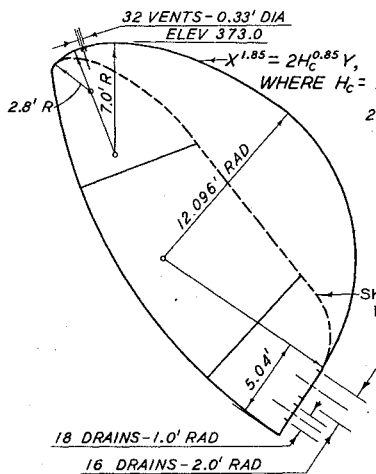

ALTERNATE V

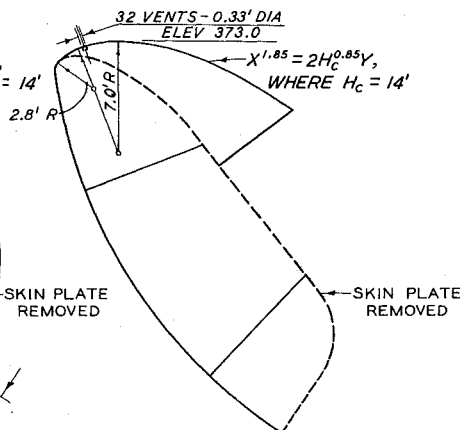

ALTERNATE W

ORIGINAL DESIGN (PLAN I) GATE  
ALTERNATES P-W

NOTE: ELEVATIONS ARE IN FEET MEAN SEA LEVEL

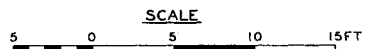

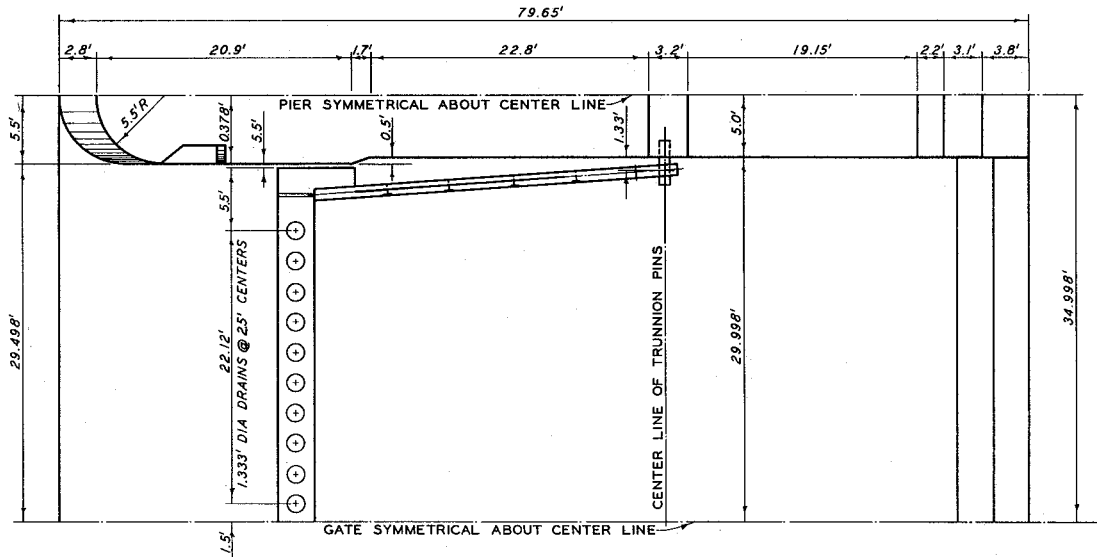

**HALF PLAN**

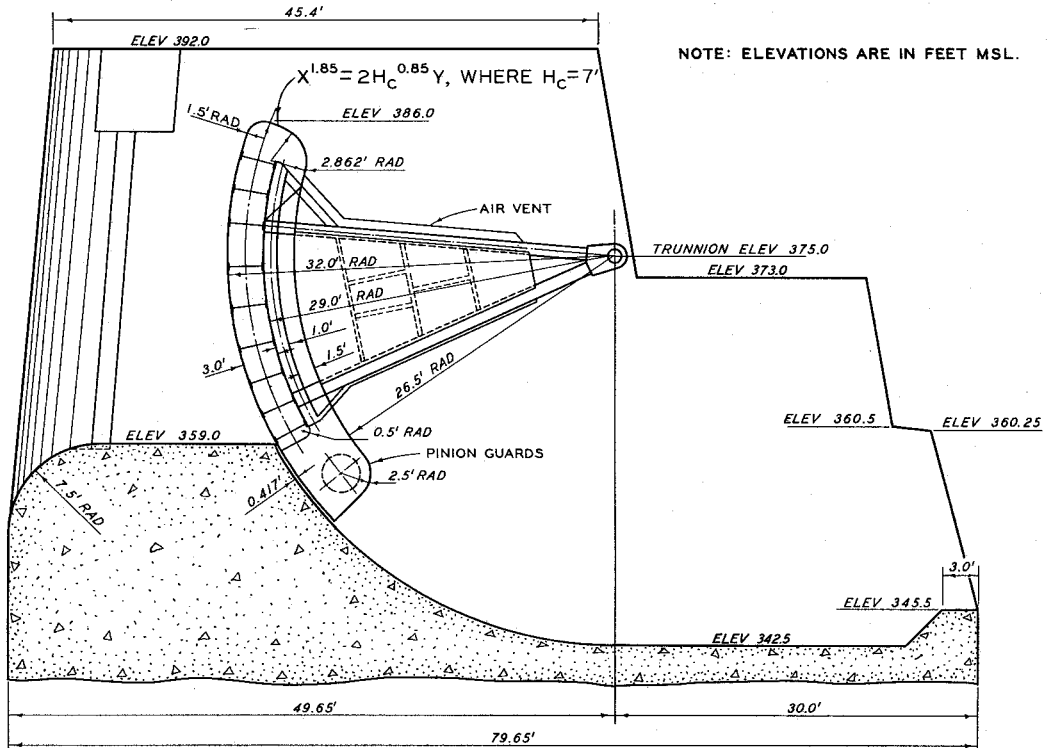

**ELEVATION ALONG CENTER LINE**

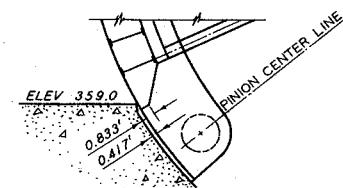

**MODIFICATION AT BOTTOM OF GATE**

**DETAILS OF SPILLWAY AND  
SUBMERSIBLE-TYPE TAITNER GATE  
REVISED DESIGN (PLAN 2)**

SCALE



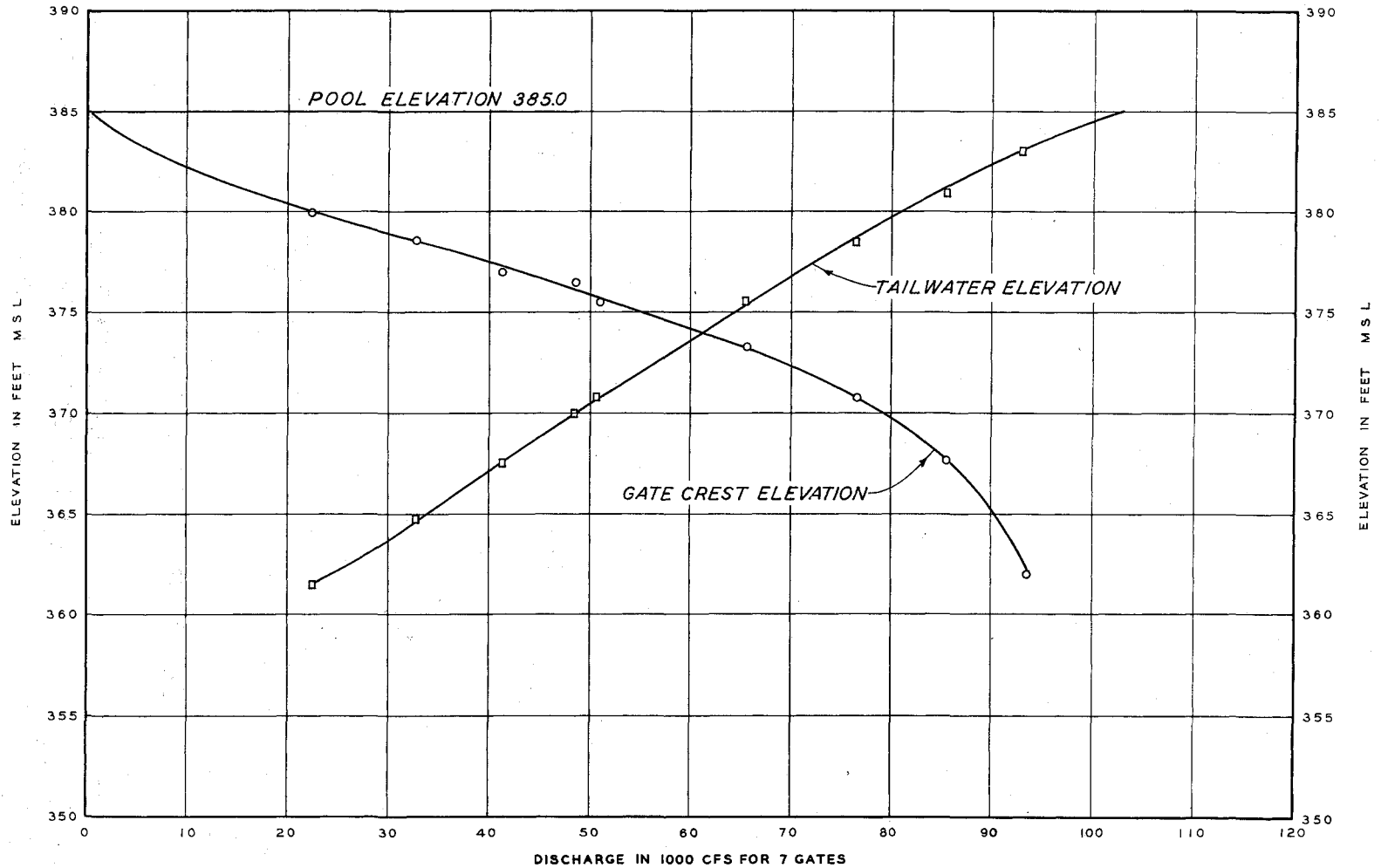

**RATING CURVE**  
GATE OPENING VS POOL AND TAILWATER ELEV  
PLAN 2 GATE

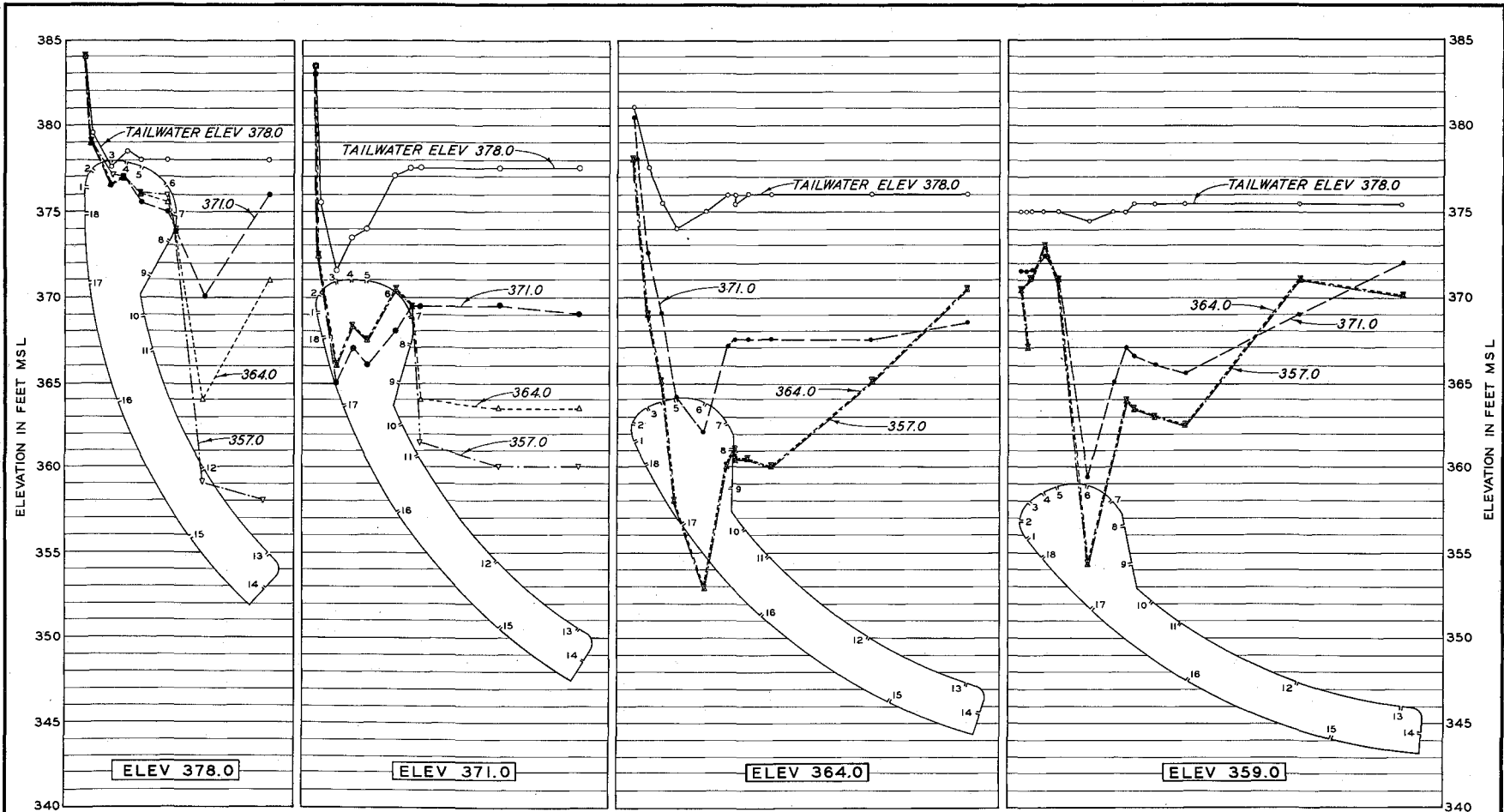

GATE CREST ELEVATIONS

NOTE: POOL MAINTAINED AT ELEV 385.0

**PRESSURES  
PLAN 2 GATE**  
HEADS OF 7, 14, 21, AND 26 FT  
TAILWATER VARIES

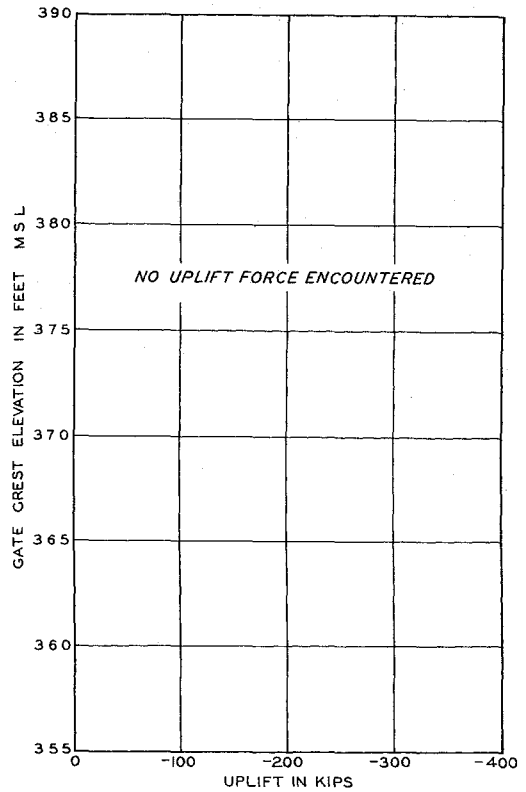
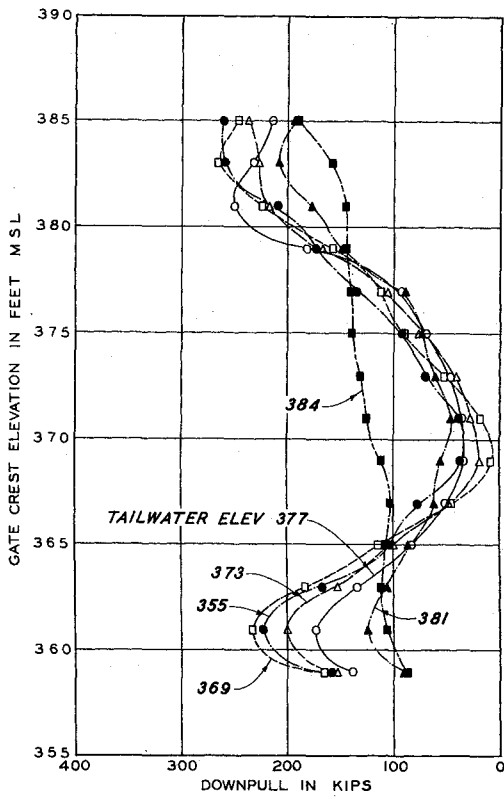

FORCES REQUIRED TO RAISE GATE

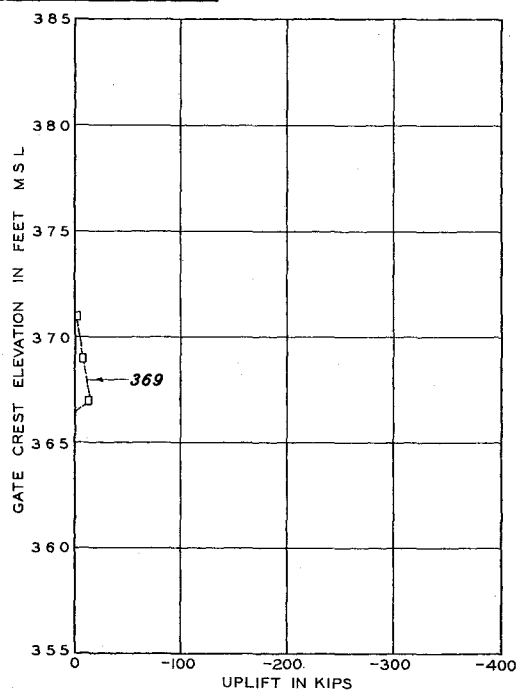
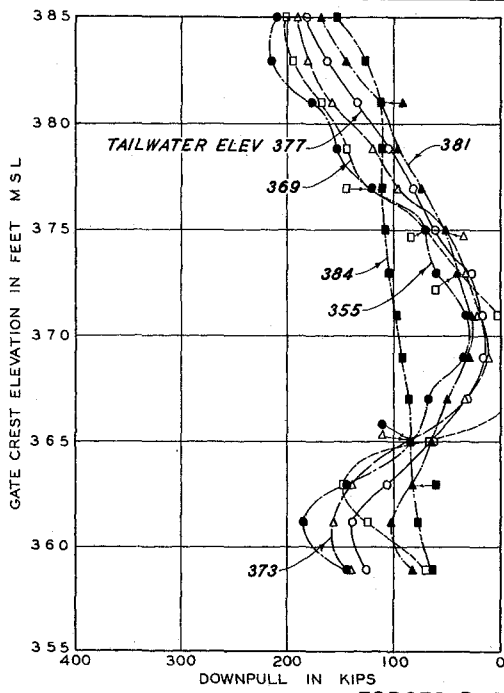

FORCES REQUIRED TO LOWER GATE

**OPERATING FORCES  
PLAN 2 GATE WITH PINION GUARD**

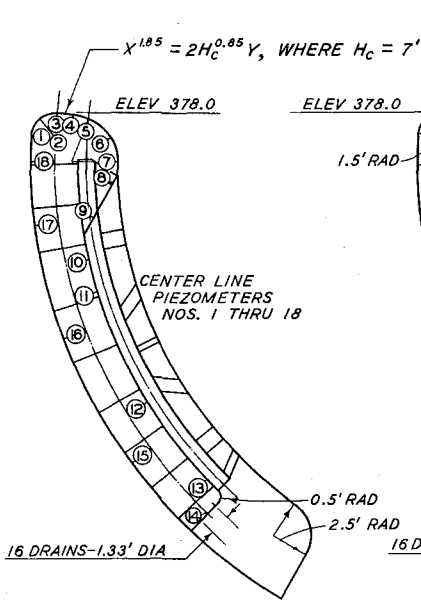

REVISED DESIGN - PLAN 2

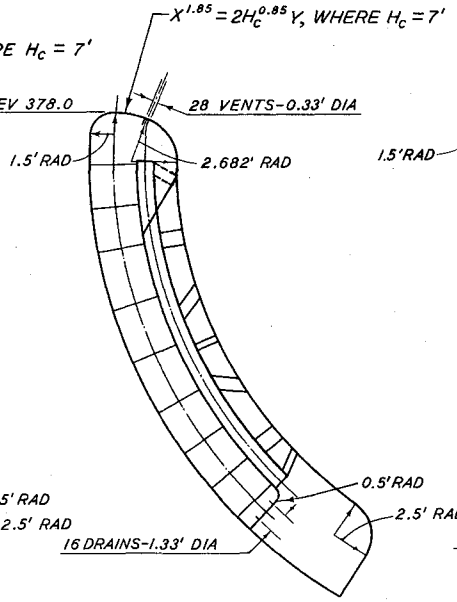

ALTERNATE A

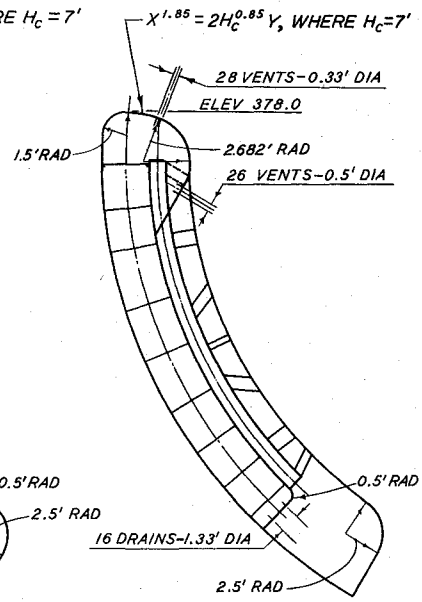

ALTERNATE B

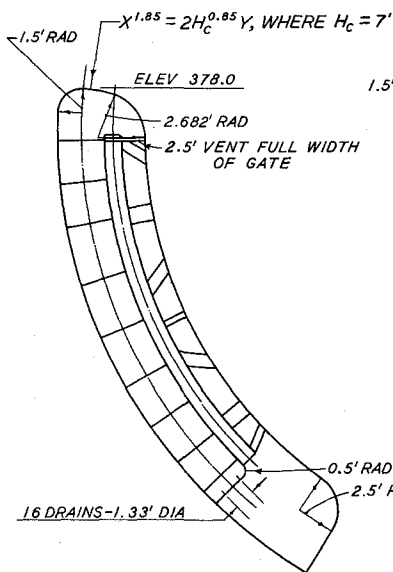

ALTERNATE C

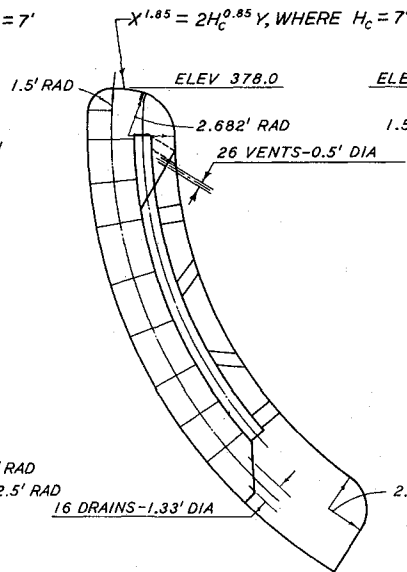

ALTERNATE D

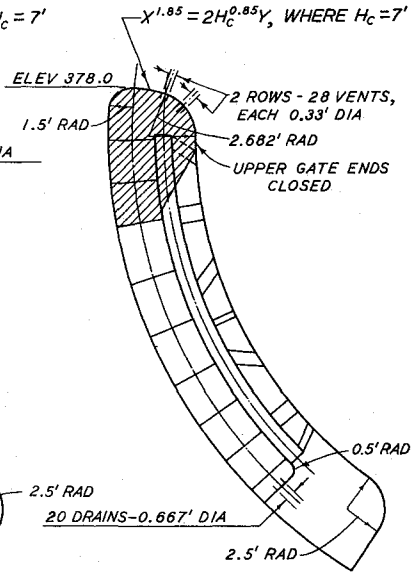

ALTERNATE E

NOTE: ELEVATIONS ARE IN FEET MEAN SEA LEVEL.

REVISED DESIGN (PLAN 2) GATE AND ALTERNATES A-E

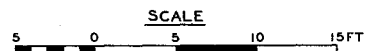

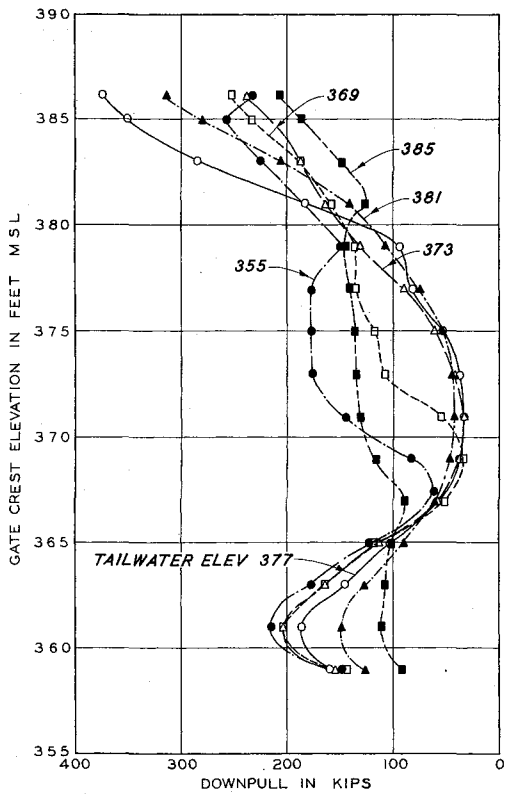

RAISING GATE - POOL ELEVATION 387.0

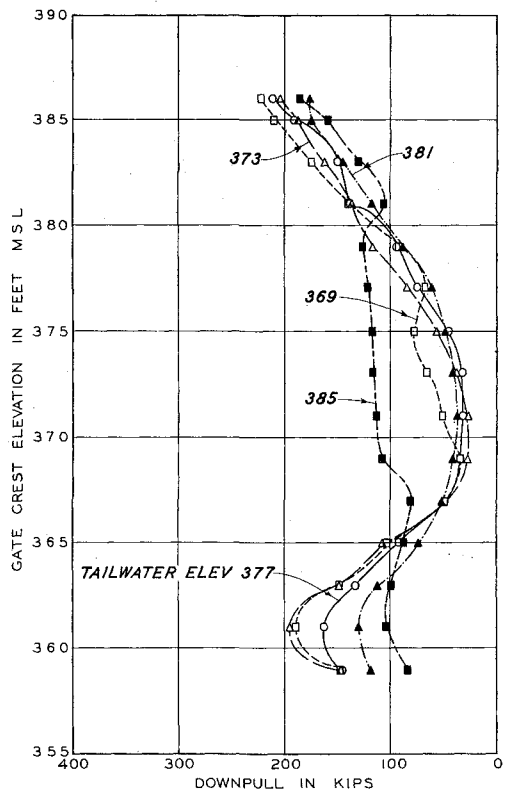

LOWERING GATE - POOL ELEVATION 387.0

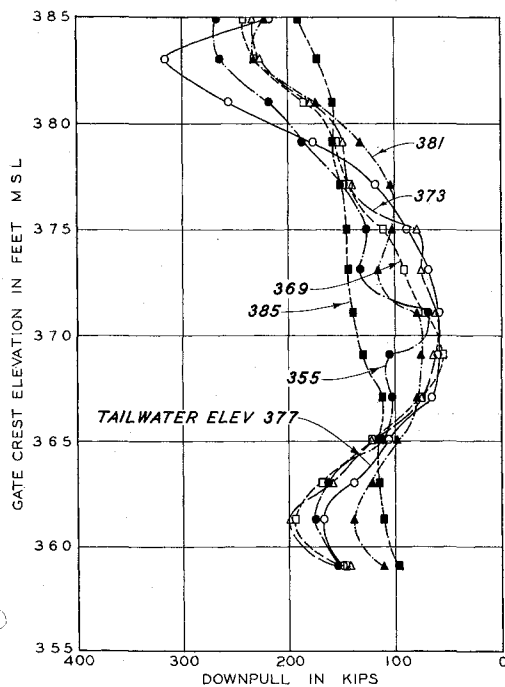

RAISING GATE - POOL ELEVATION 385.0

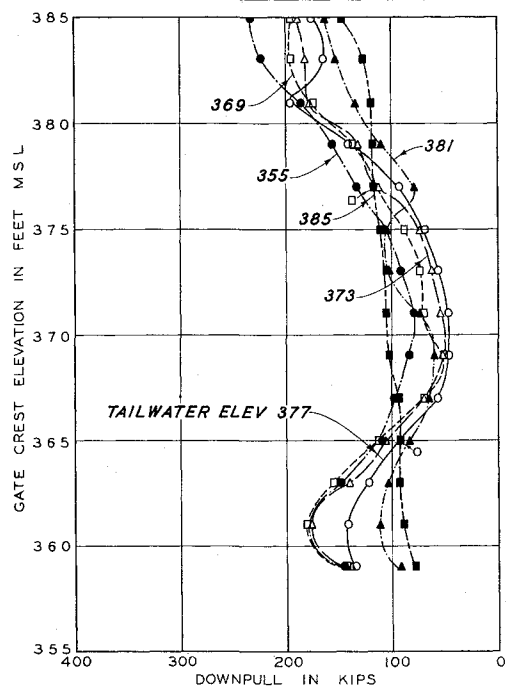

LOWERING GATE - POOL ELEVATION 385.0

**OPERATING FORCES**  
**PLAN 2 ALTERNATE E GATE**  
**POOL ELEVATIONS 387.0 AND 385.0**

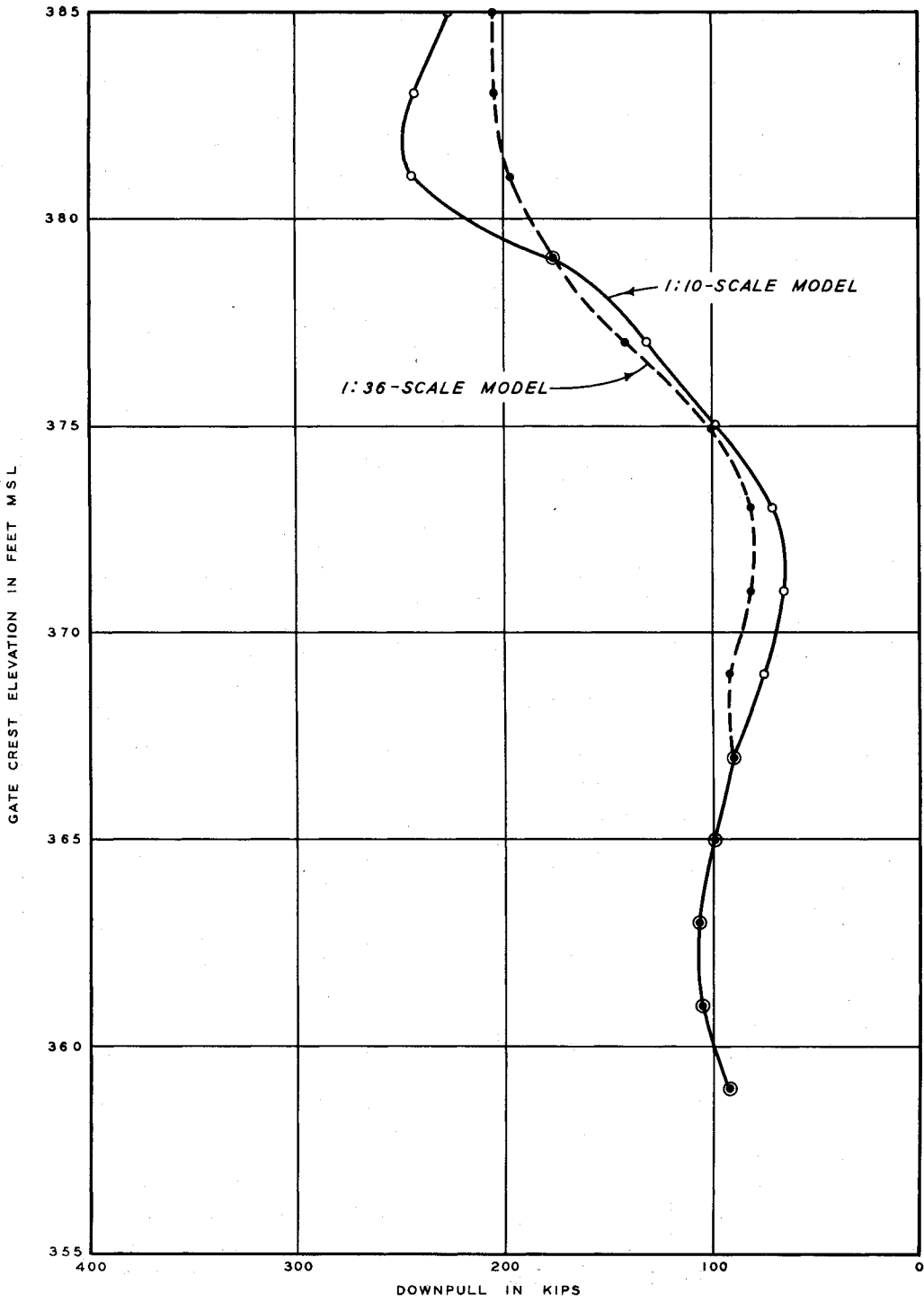

NOTE: TAILWATER BASED ON ELEV 358.6  
 TAILWATER RATING CURVE AT  
 LOCK "B" UNADJUSTED. (PLATE 22)

COMPARISON OF FORCES  
 1:36 - SCALE VS 1:10 - SCALE MODEL  
 PLAN 2 ALTERNATE E GATE

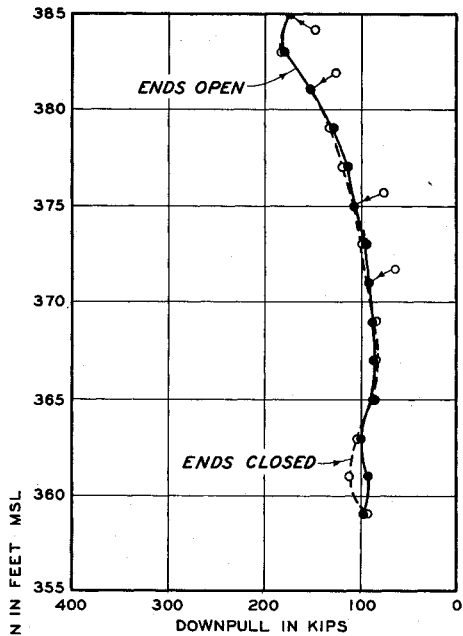

TAILWATER ELEVATION 381.0

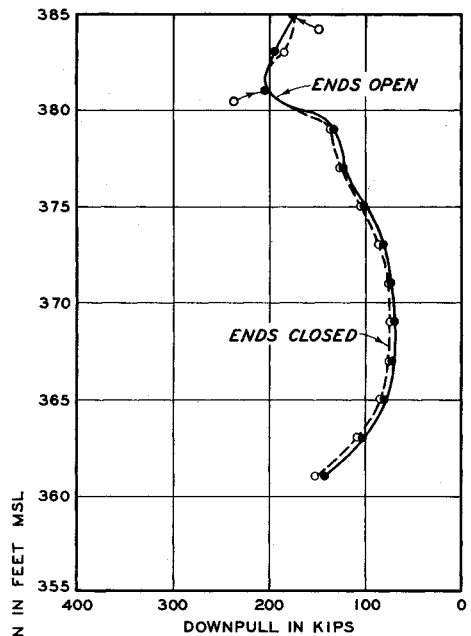

TAILWATER ELEVATION 377.0

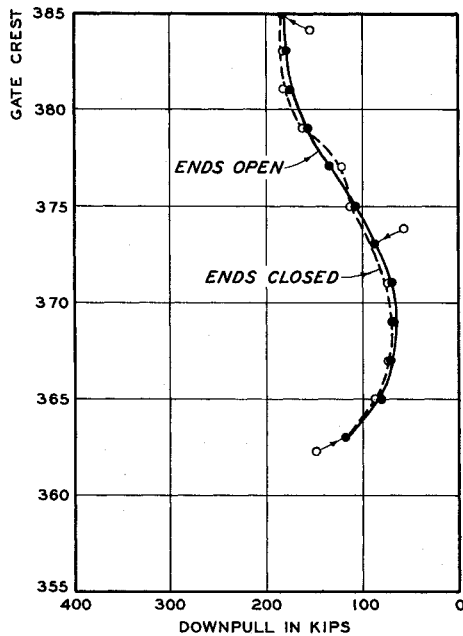

TAILWATER ELEVATION 373.0

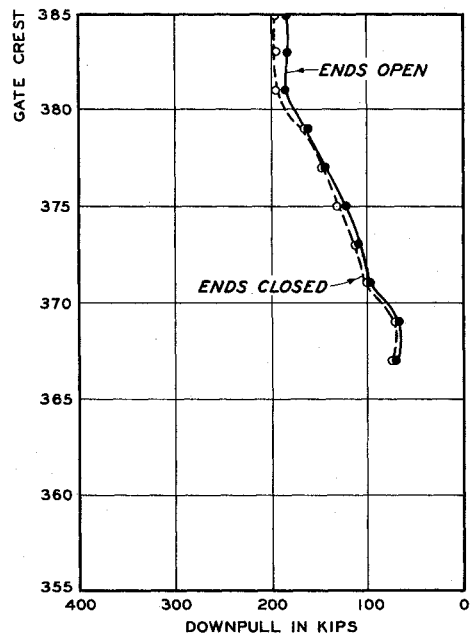

TAILWATER ELEVATION 369.0

EFFECT OF GATE ENDS  
 OPEN AND CLOSED  
 PLAN 2 ALTERNATE E GATE  
 POOL ELEVATION 385.0

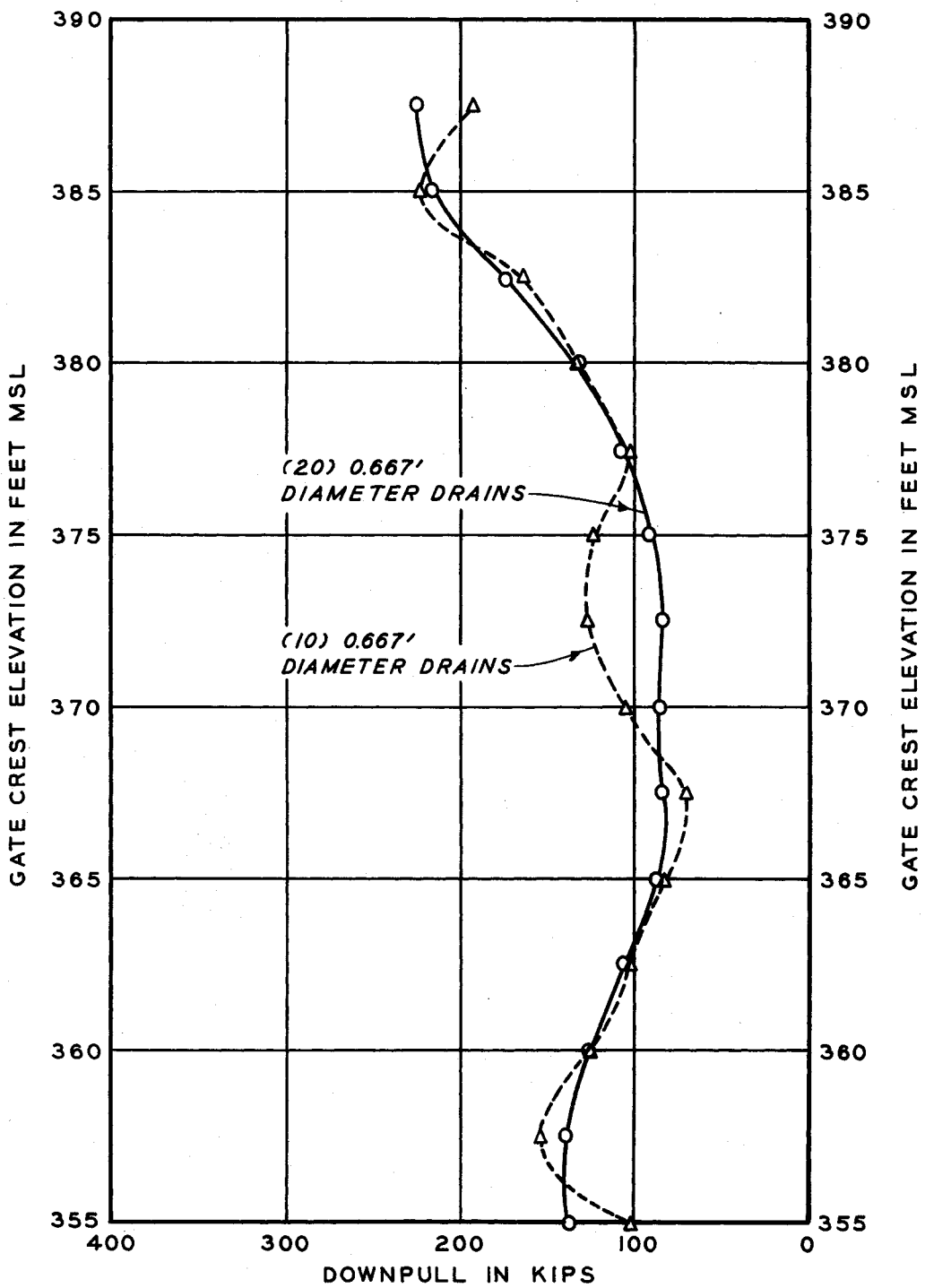

TEST CONDITIONS

POOL ELEVATION 385.0  
 TAILWATER ELEVATION 381.0

EFFECT OF BOTTOM DRAINS  
 ON PLAN 2E GATE FORCES  
 (WITH PINION GUARDS)

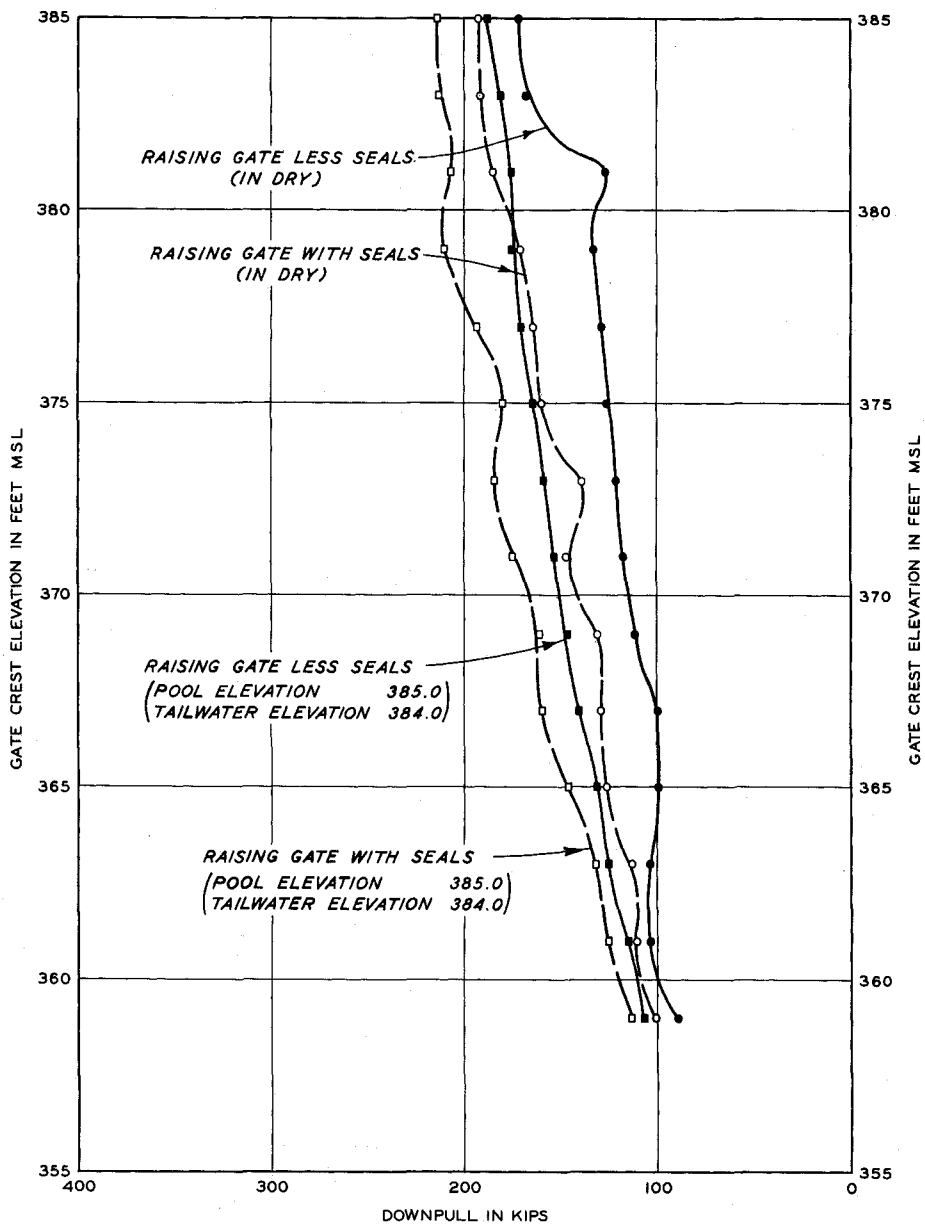

EFFECT OF GATE SEAL FRICTION  
ON OPERATING FORCES  
PLAN 2 ALTERNATE E GATE  
(WITH PINION GUARDS)

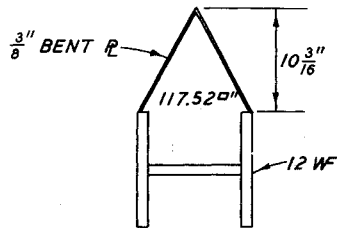
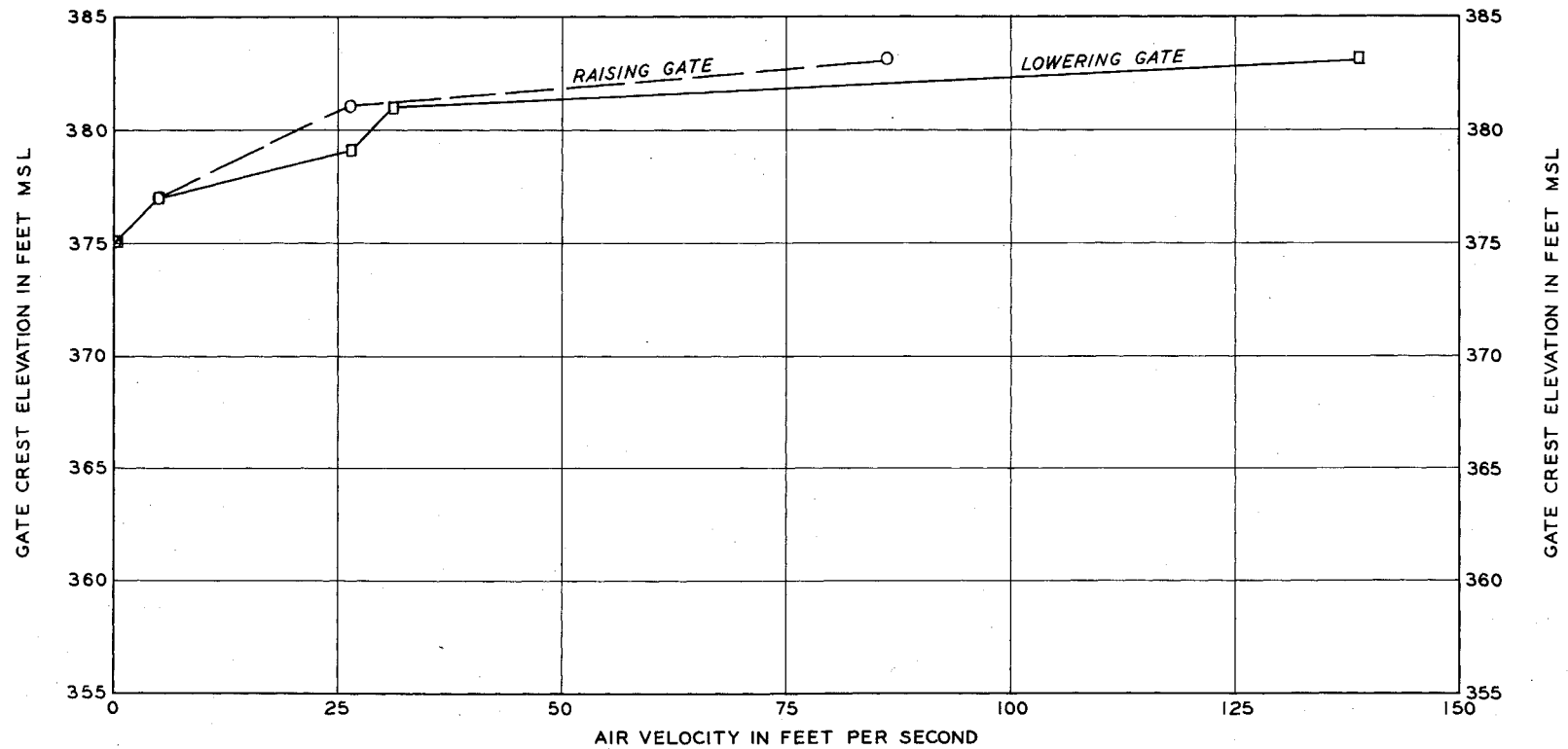

NOTE: VELOMETER WAS CENTERED HORIZONTALLY AND VERTICALLY IN THE VENT OF THE RIGHT TRUNNION ARM.

**AIR DEMAND**

ONE TRUNNION ARM AIR VENT  
PLAN 2 ALTERNATE E

DETAILS OF TRUNNION ARM AIR VENT

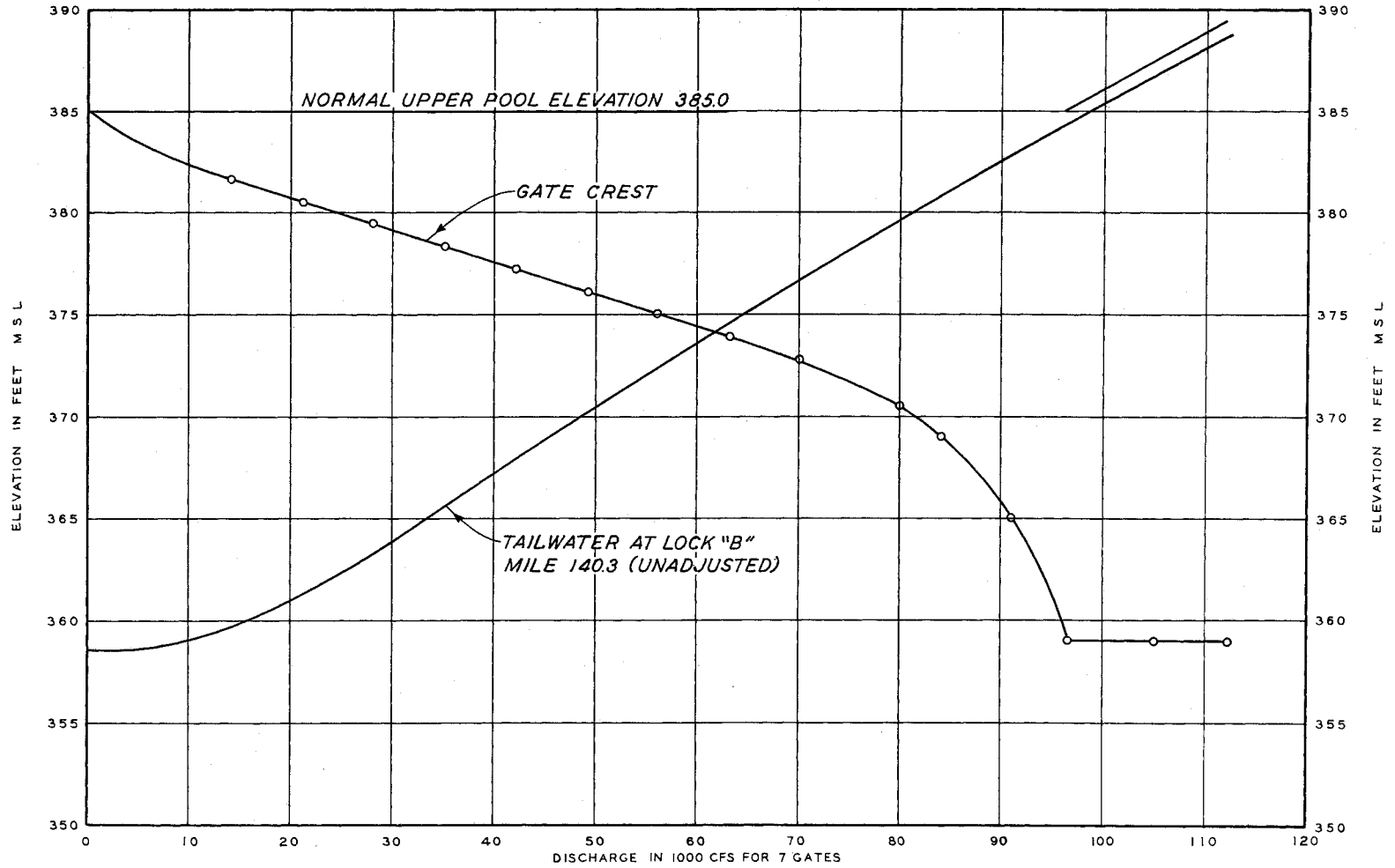

**RATING CURVE**

GATE OPENING VS POOL AND TAILWATER ELEV  
 PLAN 2 ALTERNATE E GATE WITH PINION GUARDS  
 TAILWATER ELEV 358.6 AT LOCK "B" MILE 140.3

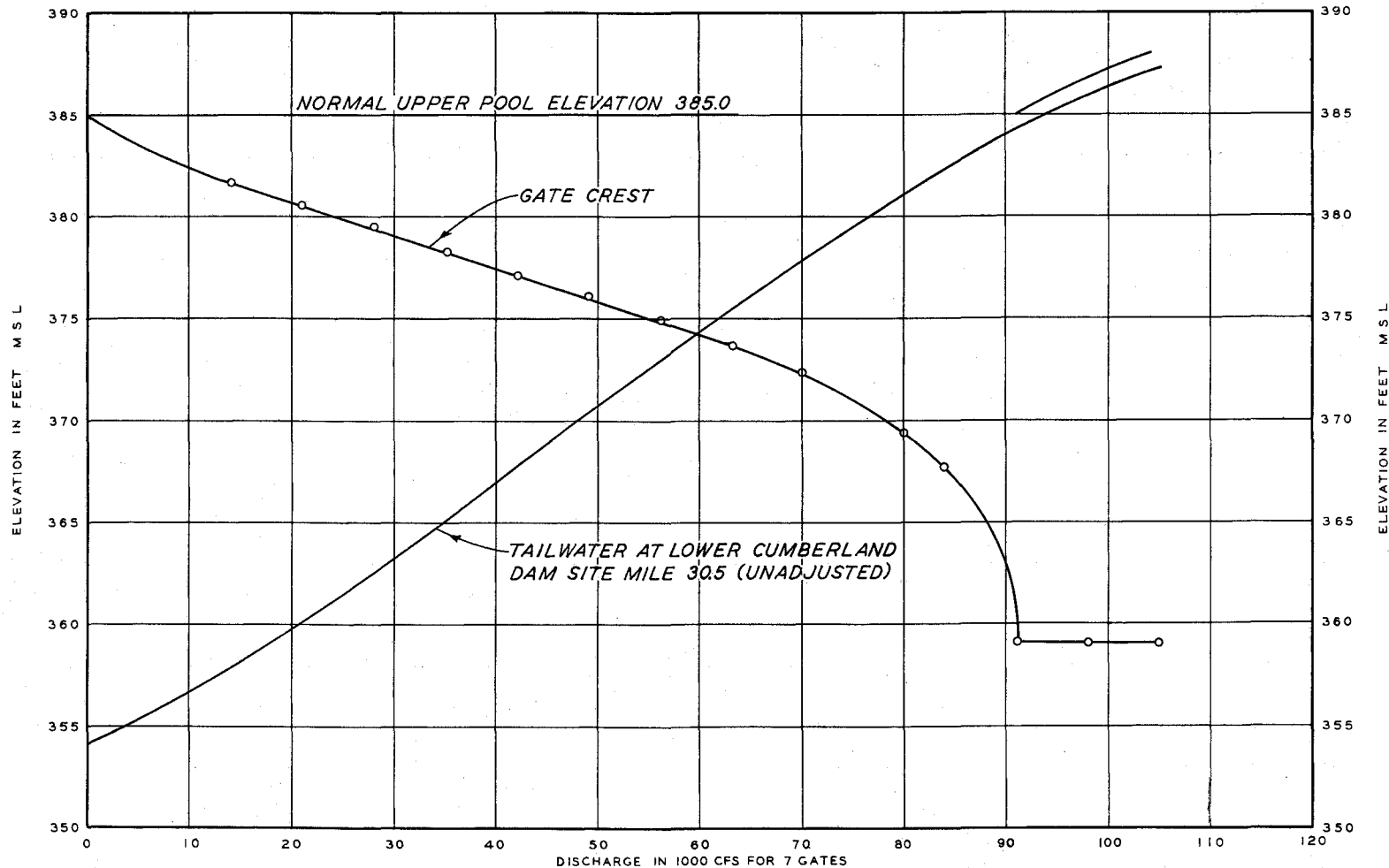

### RATING CURVE

GATE OPENING VS POOL AND TAILWATER ELEV  
 PLAN 2 ALTERNATE E GATE WITH PINION GUARDS  
 TAILWATER ELEV 354.0 LOWER CUMBERLAND DAM (MI, 30.5)

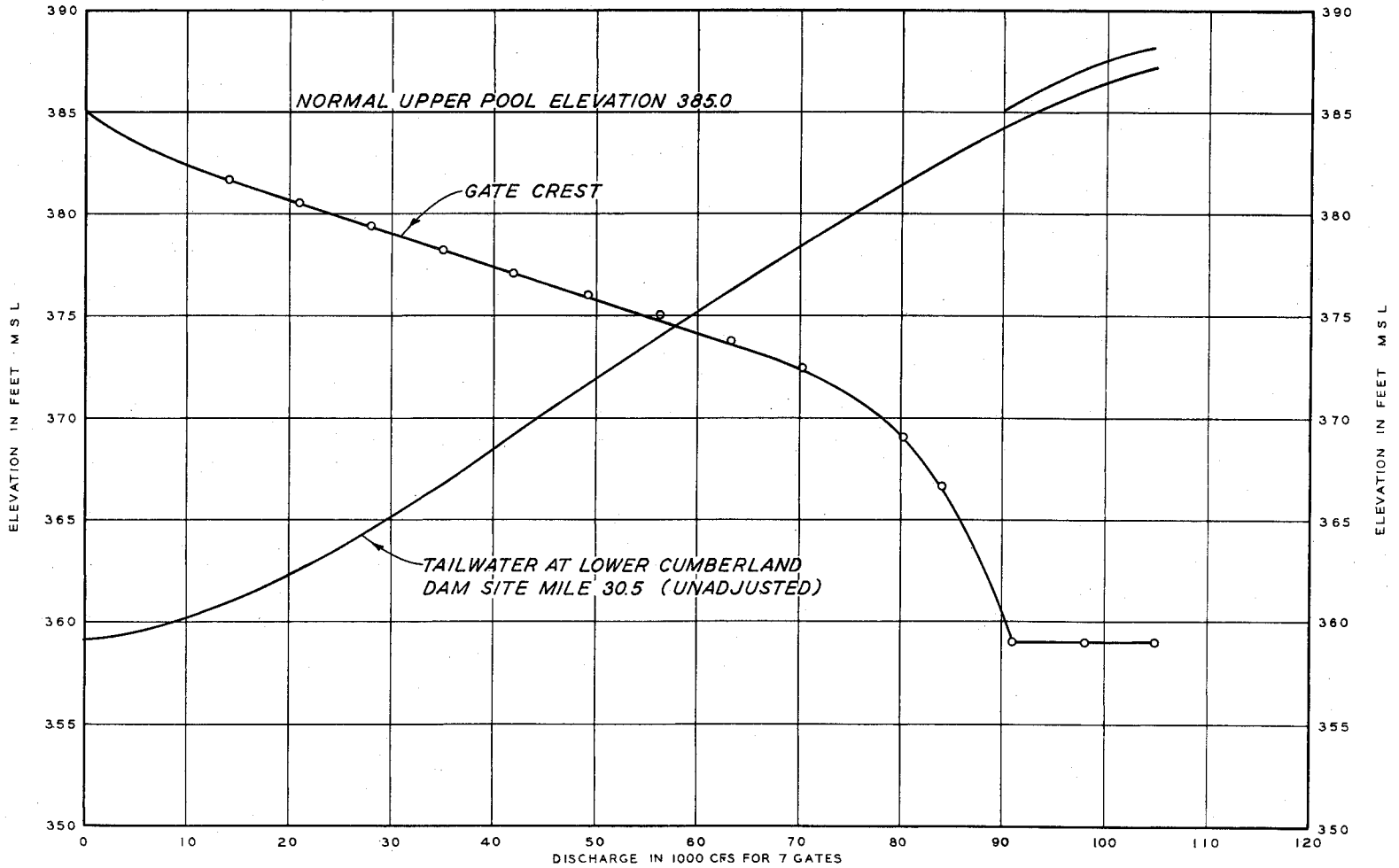

**RATING CURVE**

GATE OPENING VS POOL AND TAILWATER ELEV  
 PLAN 2 ALTERNATE E GATE WITH PINION GUARDS  
 TAILWATER ELEV 359.0 LOWER CUMBERLAND DAM (MI. 30.5)

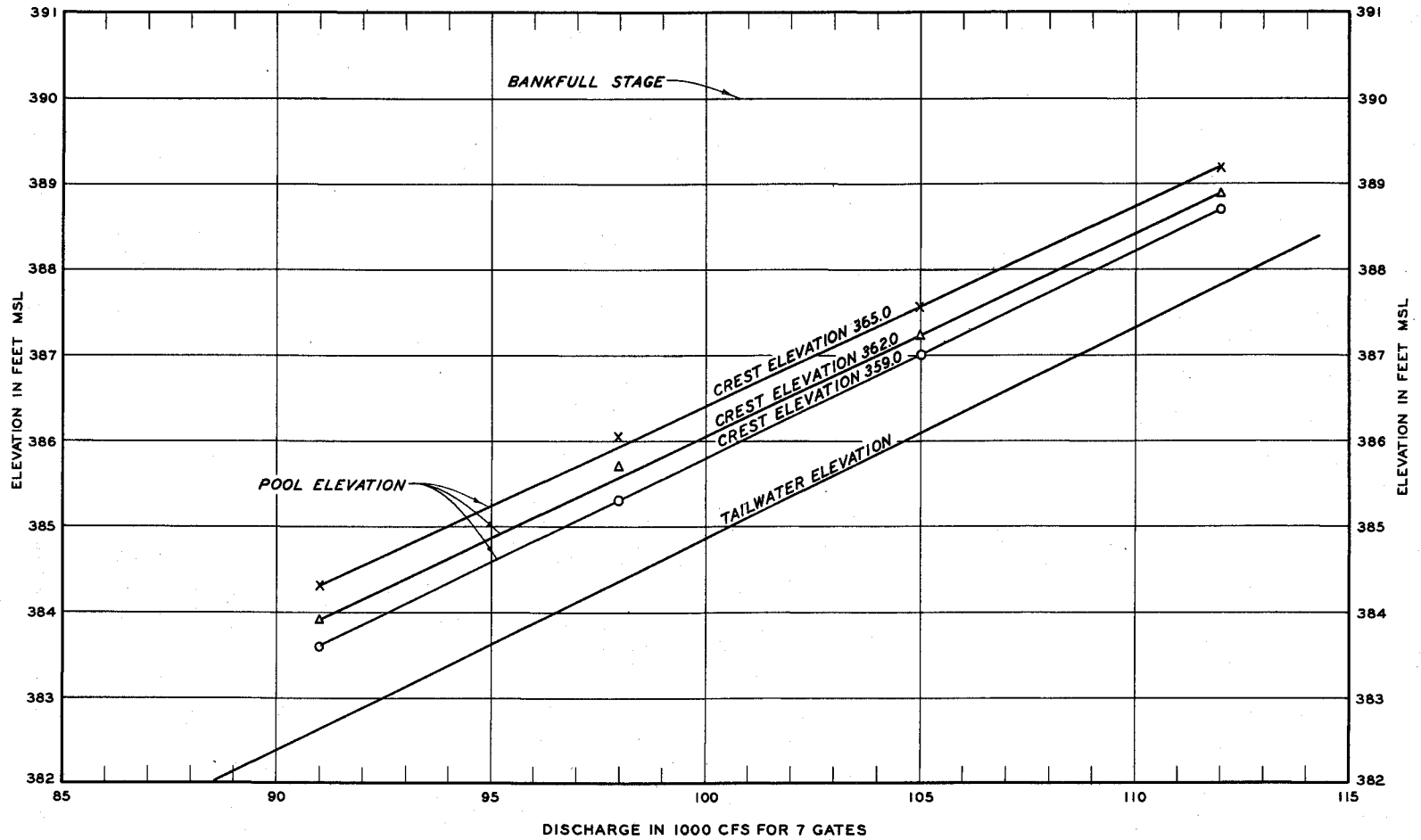

EFFECT OF SPILLWAY CREST ELEVATION ON SWELLHEAD



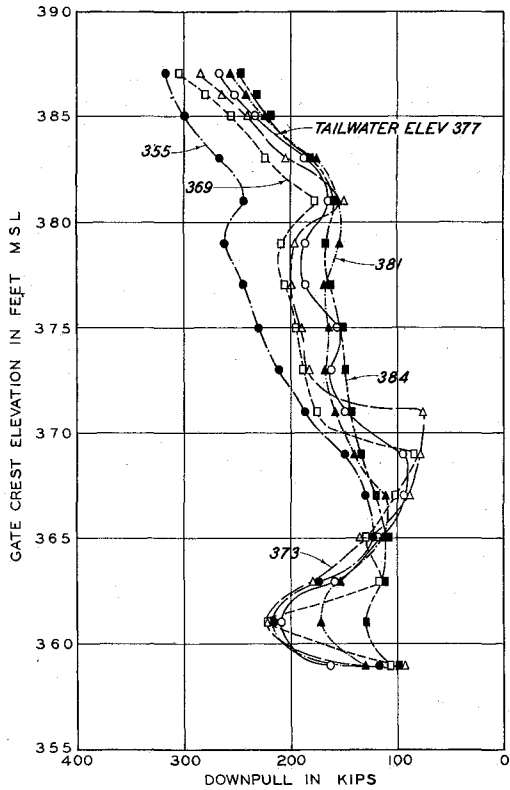

RAISING GATE - POOL ELEVATION 387.0

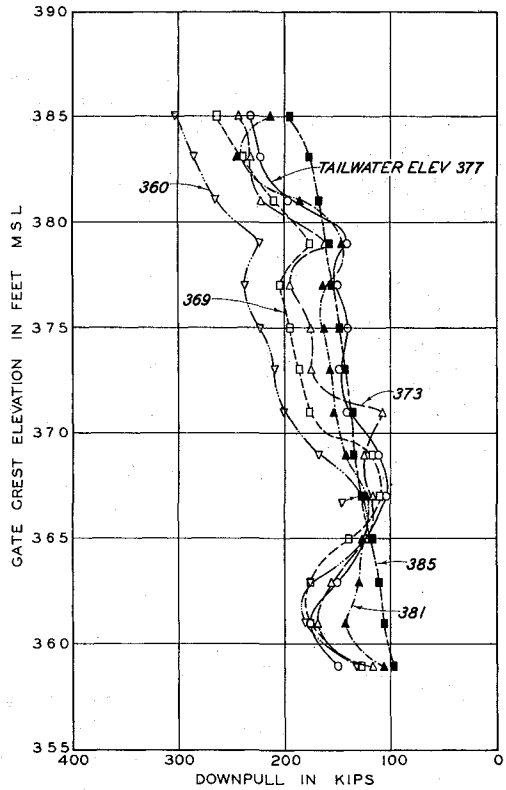

RAISING GATE - POOL ELEVATION 385.0

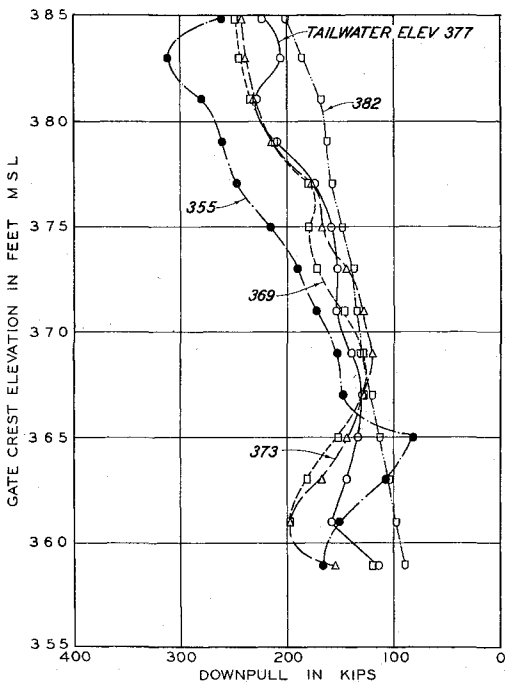

RAISING GATE - POOL ELEVATION 382.0

OPERATING FORCES  
 PLAN 3 GATE  
 POOL ELEVATIONS 387.0, 385.0 AND 382.0

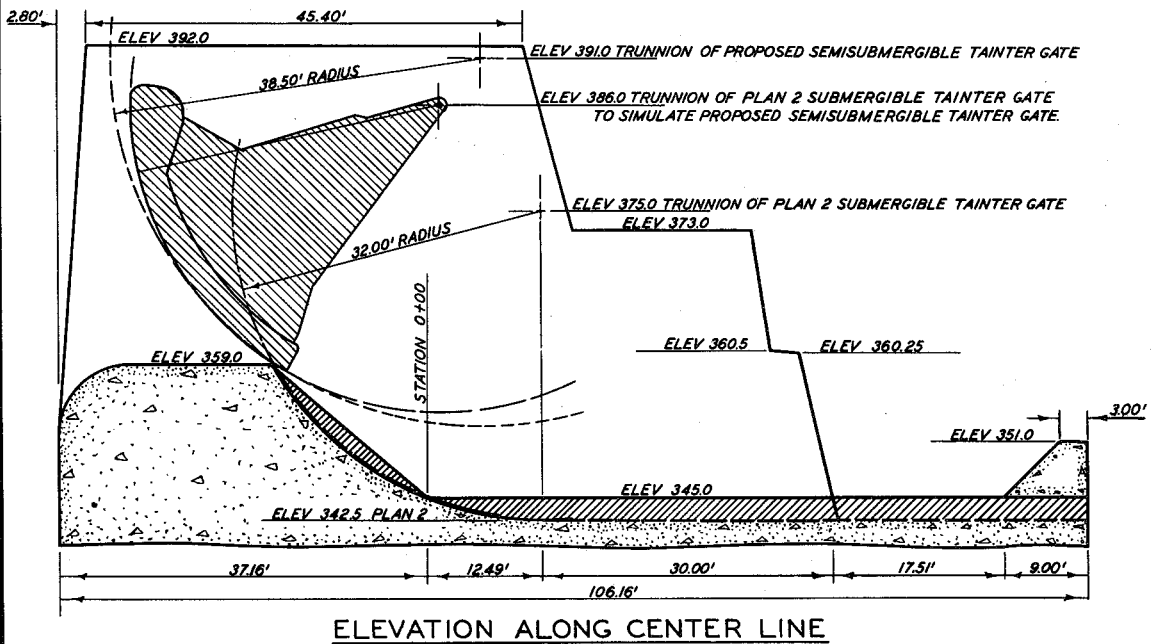
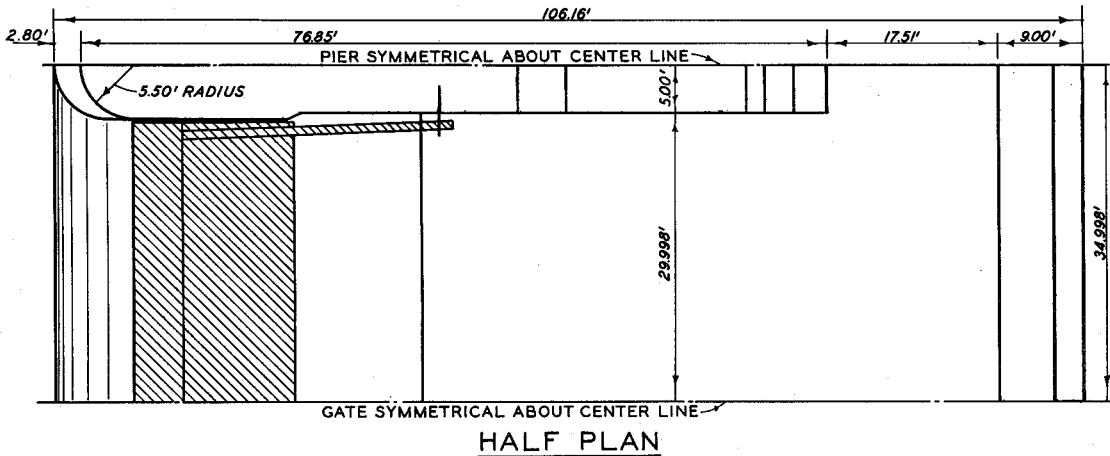

NOTE: ELEVATIONS ARE IN FEET MSL.

REVISIONS TO MODEL  
FOR SIMULATION OF FLOW  
UNDER SEMISUBMERGIBLE  
TYPE TAITER GATE

SCALE IN FEET



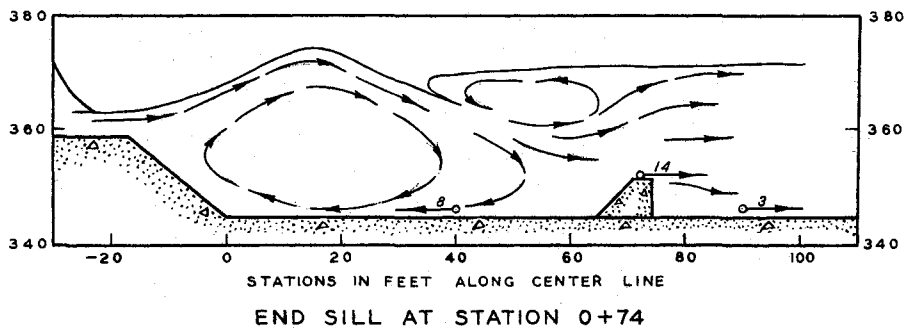
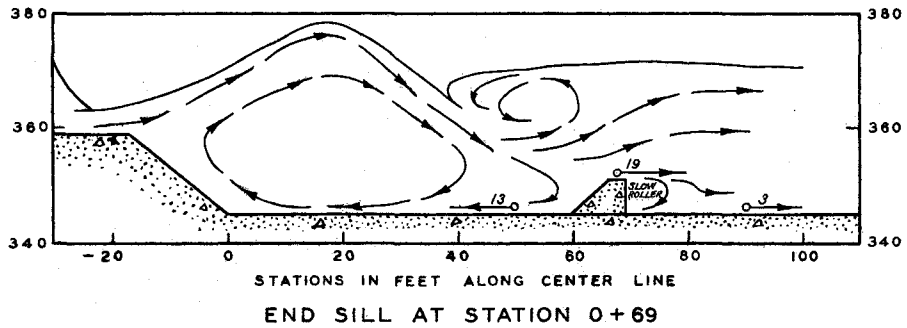
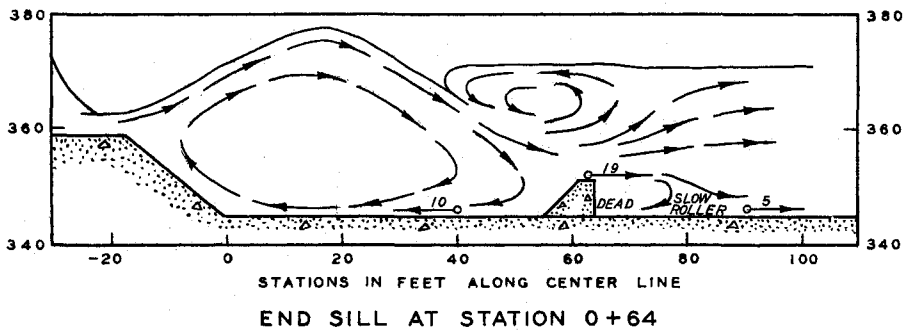
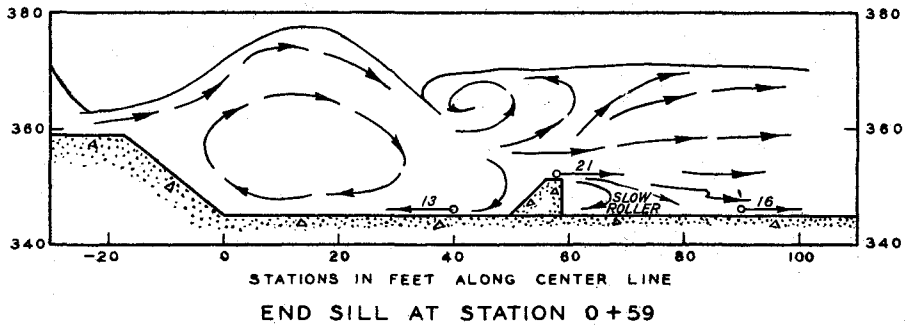

ELEVATION IN FEET MSL

ELEVATION IN FEET MSL

TEST CONDITIONS

BOTTOM GATE ELEV 363.4  
 POOL ELEV 385.0  
 TAILWATER ELEV 370.6

FLOW CONDITIONS  
 6-FT END SILL

DISCHARGE 50,000 CFS

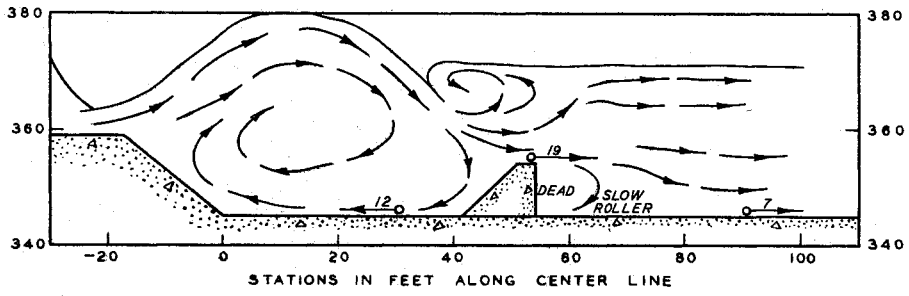

END SILL AT STATION 0+54

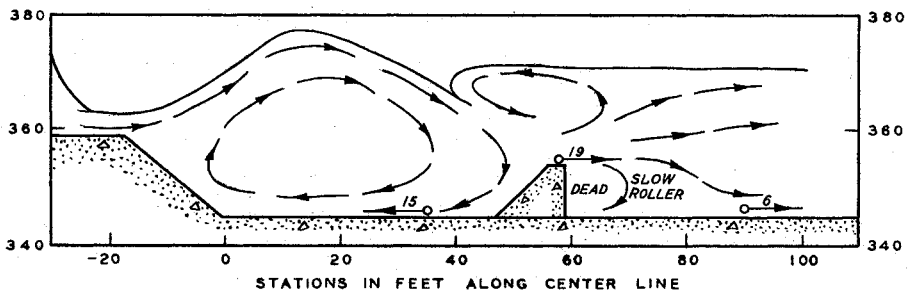

END SILL AT STATION 0+59

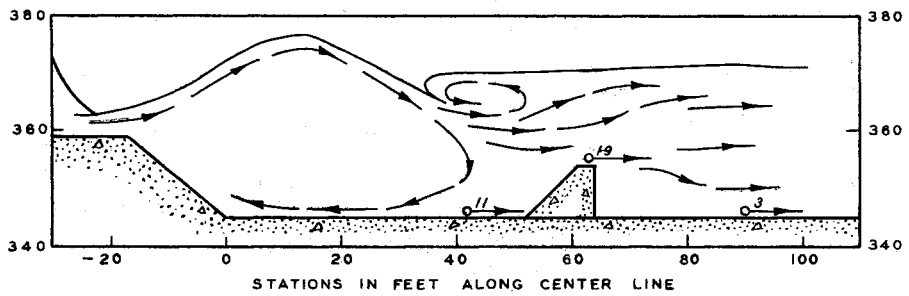

END SILL AT STATION 0+64

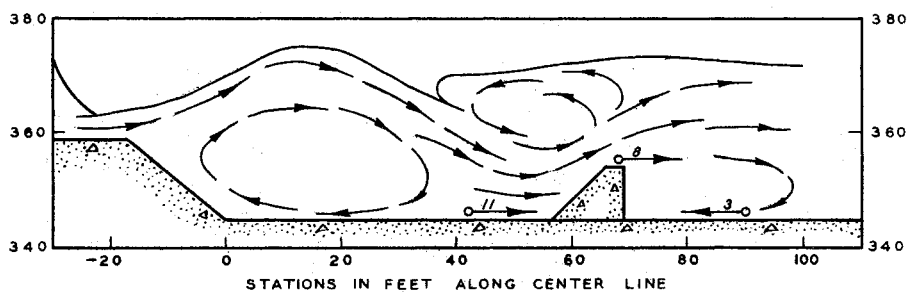

END SILL AT STATION 0+69

TEST CONDITIONS

BOTTOM GATE ELEV	363.4
POOL ELEV	385.0
TAILWATER ELEV	370.6

FLOW CONDITIONS  
 9-FT END SILL  
 DISCHARGE 50,000 CFS

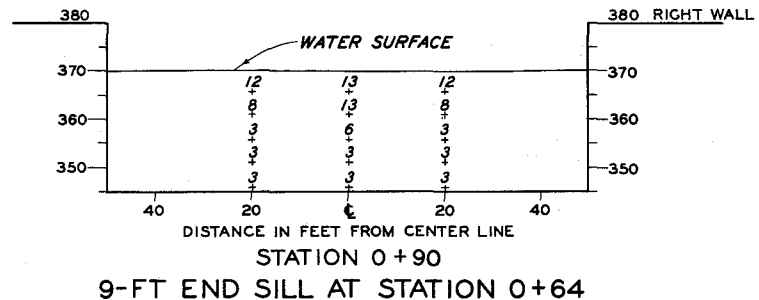
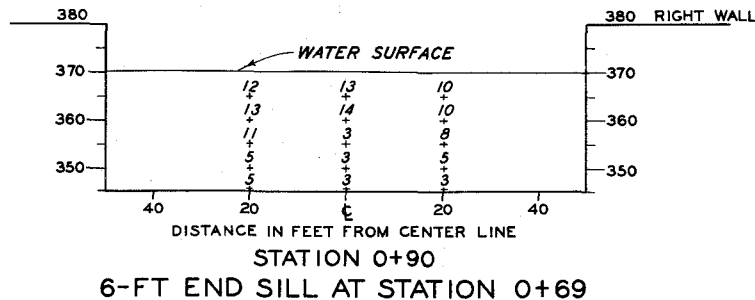
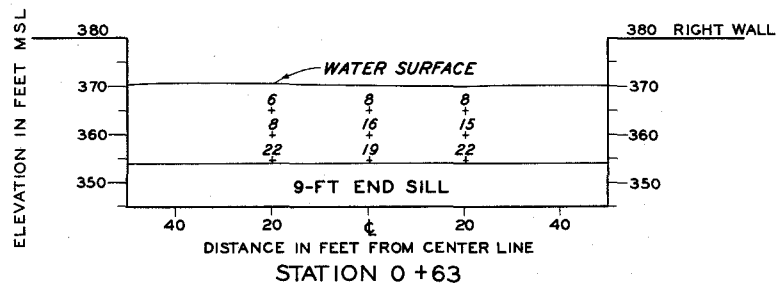
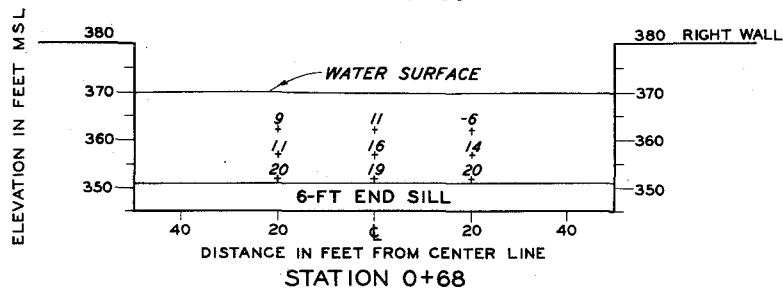
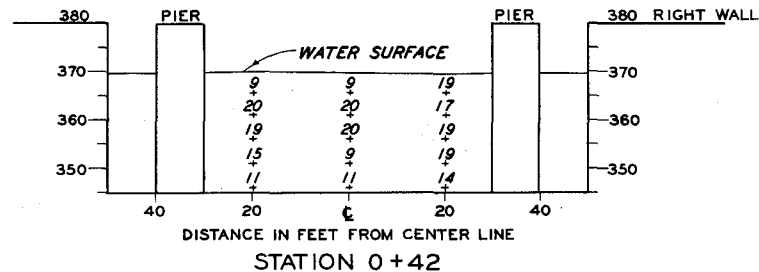
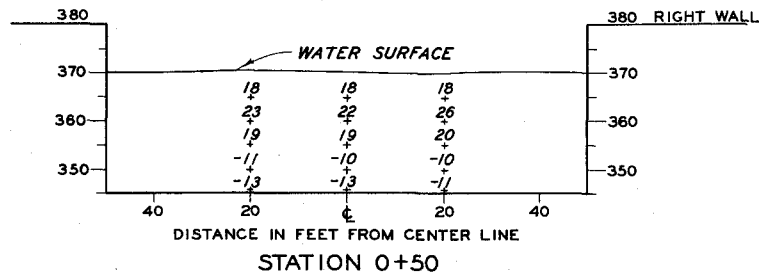

TEST CONDITIONS

POOL ELEV 385.0  
TAILWATER ELEV 370.6

**VELOCITY COMPARISON**

6-AND 9-FT END SILLS  
SEMISUBMERGIBLE TAINTER GATE  
DISCHARGE 50,000 CFS

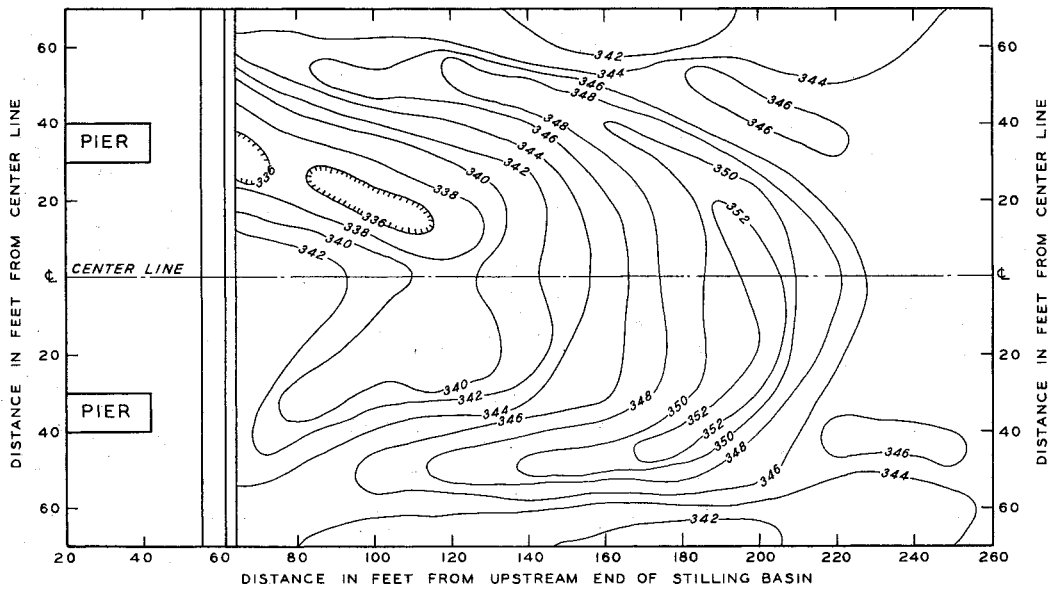

6-FT END SILL AT STATION 0 + 64

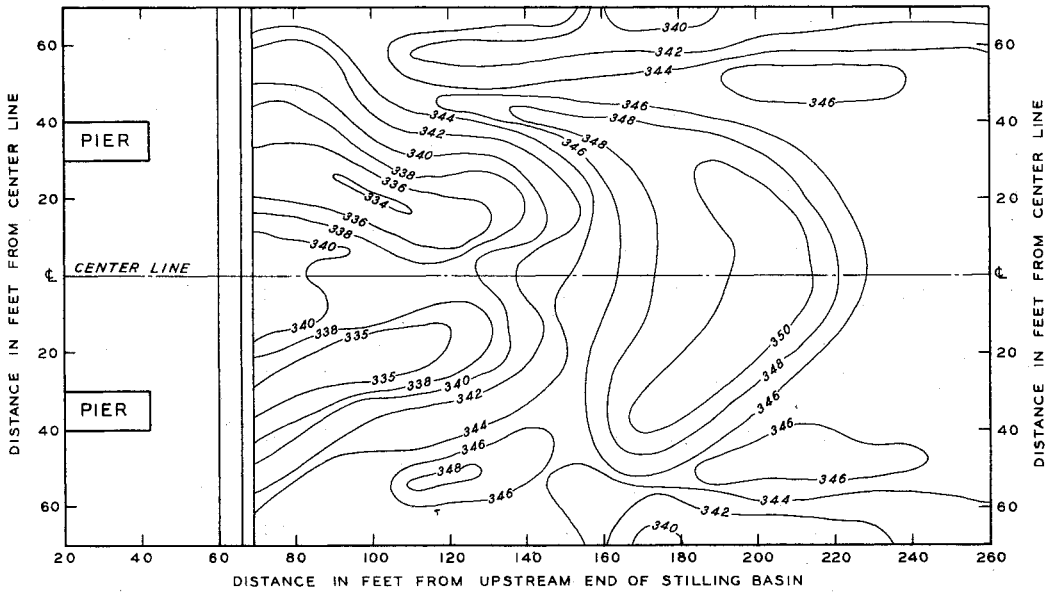

6-FT END SILL AT STATION 0 + 69

TEST CONDITIONS

POOL ELEV 385.0  
 TAILWATER ELEV 370.6  
 TIME OF SCOUR 6 HR

NOTE: ELEVATIONS ARE IN FEET MEAN  
 SEA LEVEL. BED OF EXIT CHANNEL  
 BELOW END SILL MOLDED IN SAND  
 TO ELEVATION 351.0

**COMPARISON OF SCOUR PATTERNS  
 6-FT END SILL**

STATION 0+64 VS STATION 0+69  
 DISCHARGE 50,000 CFS

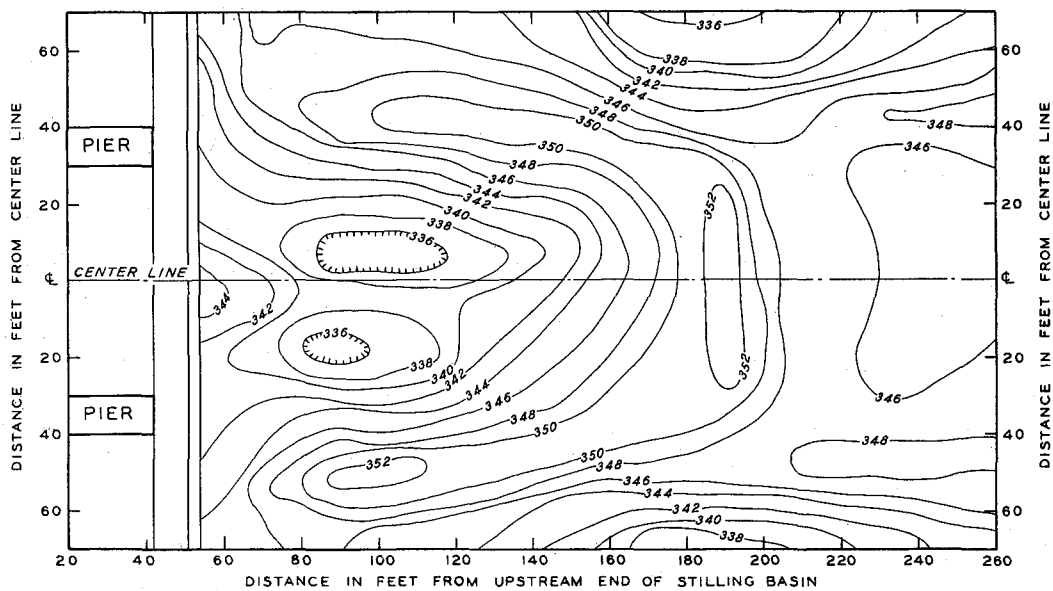

9-FT END SILL AT STATION 0+54

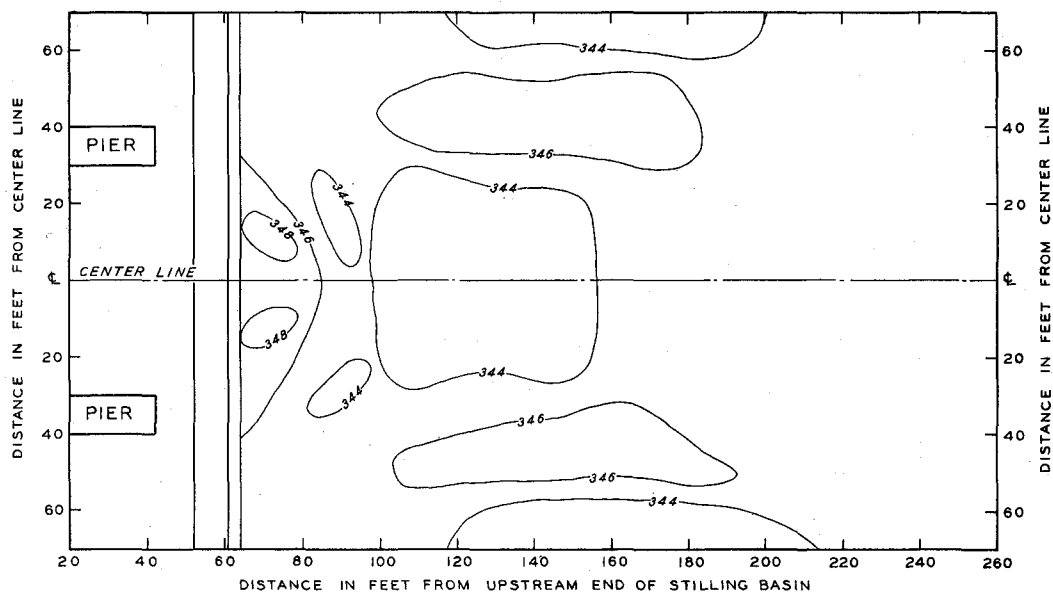

9-FT END SILL AT STATION 0+64

TEST CONDITIONS

POOL ELEV        385.0  
 TAILWATER ELEV  370.6  
 TIME OF SCOUR    6 HR.

NOTE: ELEVATIONS ARE IN FEET MEAN  
 SEA LEVEL. BED OF EXIT CHANNEL  
 BELOW END SILL MOLDED IN SAND  
 TO ELEVATION 354.0

**COMPARISON OF SCOUR PATTERNS  
 9-FT END SILL**

STATION 0+54 VS STATION 0+64  
 DISCHARGE    50,000 CFS

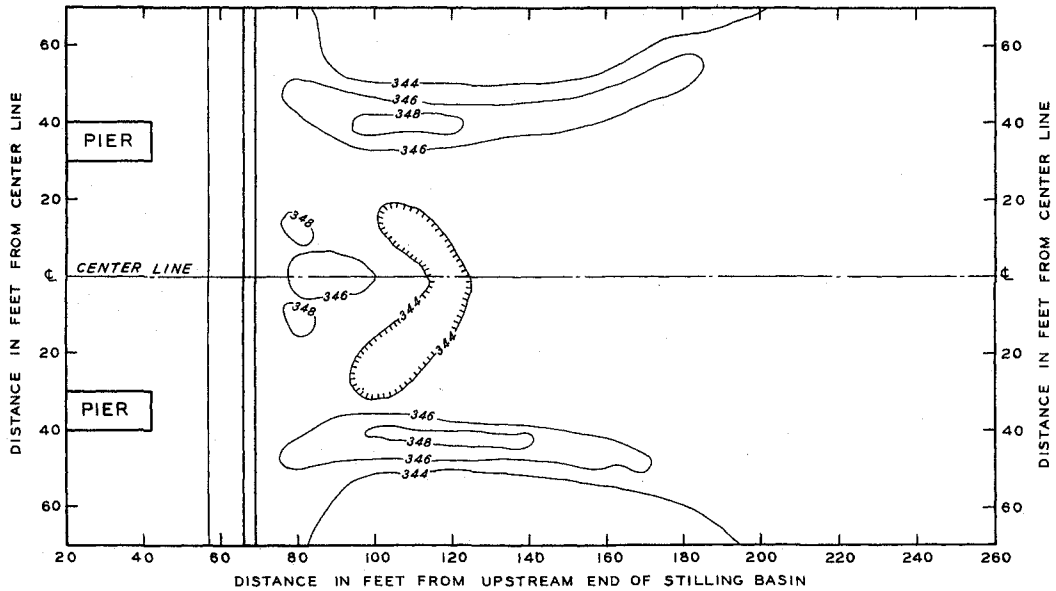

9-FT END SILL AT STATION 0+69

TEST CONDITIONS

POOL ELEV 385.0  
 TAILWATER ELEV 370.6  
 TIME OF SCOUR 6 HR

NOTE: ELEVATIONS ARE IN FEET MEAN  
 SEA LEVEL. BED OF EXIT CHANNEL  
 BELOW END SILL MOLDED IN SAND  
 TO ELEVATION 354.0

SCOUR PATTERN  
 9-FT END SILL

STATION 0+69  
 DISCHARGE 50,000 CFS