

# AN FET FULL BRIDGE SWITCHER FOR INDUCTORLESS CAPACITOR CHARGING FOR NOVA\*

A. M. Mihalka, R. E. Burch, B. T. Merritt  
Lawrence Livermore National Laboratory  
P.O. Box 5508, L-494  
Livermore, CA 94550

## Summary

Switching power supplies were designed for the Nova 10 mm rod amplifiers. A simmer supply keeps the lamp turned on continuously by providing 70 - 110 milliamperes of dc current while a flashlamp supply repeatedly charges and regulates a capacitor before its energy is dumped into the lamp. The chief difference in these two supplies is their output transformer.

A full bridge configuration using power MOSFET's is simple to drive. The transformer is designed to provide adequate inductance to limit rate of rise of charging current to an acceptable level. Fast recovery diodes in the bridge provide excellent FET turn off characteristics, eliminate ringing through the transistors, and provide a path for transformer energy to be transferred to the load at the end of each cycle.

The output of the simmer power supply is a 35 microfarad capacitor in parallel with the lamp, so initially it must also charge a capacitor. The peak output voltage is 3.6 kv, but it is normally operated at 2.0 kv. The flashlamp power supply load is 120 microfarads. Its maximum voltage output is 5.0 kv and is typically run at 3.0 kv. It can charge its output to one kilojoule in much less than the maximum ten seconds allowed, but cannot do this indefinitely without overheating the transformer. However, the amplifier glass rod will fail before the transformer will. Both power supplies produce an average power of 300 watts and a peak power of 1,650 watts. However, the transistors are medium power and are conservatively run at 6 amperes peak, so they are capable of producing a much higher average power when combined with a higher power transformer. Very high power is realizable by paralleling high power transistors. Both supplies regulate to  $\pm 2$  volts at maximum output.

Conventional current limit methods are not fast enough to be useful for our application. We therefore designed a control loop that counts pulses and accordingly varies the pulse width as the capacitor charges. In this way the current peaks remain high throughout the charge cycle, and the frequency varies from 50 kHz down to 20 kHz. We do not pulse width modulate; only whole pulses are allowed. Several key signals are available so that the pulse width may be externally controlled by a microprocessor or a computer to drive special loads. Refer to related paper entitled "A Programmable Controller With Overcurrent Latch for Constant Primary Peak Current in Capacitor Charging FET Switcher for Nova" for more details of the counting circuit and control loop, and for an oscilloscope trace of the current envelope.

## Bridge Circuit

The full bridge power circuit is shown in Figure 1. Three phase 208 Vac is full wave rectified to get approximately + 150 Vdc. All diodes shown are the fast recovery type. The transistors are IRF 440 power MOSFET's having a peak continuous drain current of 8 amperes. These were chosen because their voltage and current ratings exceeded our requirements and their cost was low. Each transistor has a snubber to limit turn off spikes and a series diode to prevent bridge ringing.

The transformer uses an EC 70 core, which is an E core with a circular center leg. Capacitors on either side of it prevent imbalances in the on-times of diagonal transistor pairs from building up a dc flux bias and saturating the core. Diodes connected to the transformer primary provide a path for primary current to decay to zero, thus releasing transformer stored energy to the load. The secondary is connected to a full wave rectifier made up of 7 kv, fast recovery diodes. The rectifier output is connected directly to the 5 kv output capacitor without the benefit of an inductor.

## Transformer

A few iterations were necessary to arrive at the final design of the transformers. At first we tried a 60 turn primary for each transformer. This kept magnetizing current low and did not heat up the core. However, the leakage reactance was so high that the time required to reach the primary current peak was very long and saturated the core on each pulse. We then went to a 40 turn primary with a 1.5 mil gap in each leg. This also made it easier to wind the secondary, since proportionately less turns are needed.

For the simmer supply we found that the core did not saturate or heat up, but some adjustments were necessary to increase the leakage to get the 250 microhenries we wanted. Each primary and secondary is wound on a separate bobbin, and by separating them as much as possible on the center leg of the core we get maximum leakage. To keep the number of turns low and increase the leakage we used bobbins that were as short as possible; that is, each winding completely filled the area between the center and outside legs.

It was impossible to build the flashlamp transformer with the EC 70 core using a 40 turn primary and get the 350 microhenry leakage we wanted. We increased the primary turns to 50 using larger bobbins that were also larger diameter, which allows for better cooling between winding and core. This transformer turned out to be very adjustable and in the range we wanted.

Both transformers have performed reliably at the duty required by the laser amplifier. All windings are vacuum impregnated. A higher average output power transformer for the same load would necessitate using a different core and larger wire.

\*Work performed under the auspices of the U. S. Department of Energy by the Lawrence Livermore National Laboratory under contract number W-7405-ENG-48.

# Report Documentation Page

Form Approved  
OMB No. 0704-0188

Public reporting burden for the collection of information is estimated to average 1 hour per response, including the time for reviewing instructions, searching existing data sources, gathering and maintaining the data needed, and completing and reviewing the collection of information. Send comments regarding this burden estimate or any other aspect of this collection of information, including suggestions for reducing this burden, to Washington Headquarters Services, Directorate for Information Operations and Reports, 1215 Jefferson Davis Highway, Suite 1204, Arlington VA 22202-4302. Respondents should be aware that notwithstanding any other provision of law, no person shall be subject to a penalty for failing to comply with a collection of information if it does not display a currently valid OMB control number.

1. REPORT DATE <b>JUN 1983</b>		2. REPORT TYPE <b>N/A</b>		3. DATES COVERED <b>-</b>	
4. TITLE AND SUBTITLE <b>An Fet Full Bridge Switcher For Inductorless Capacitor Charging For Nova</b>				5a. CONTRACT NUMBER	
				5b. GRANT NUMBER	
				5c. PROGRAM ELEMENT NUMBER	
6. AUTHOR(S)				5d. PROJECT NUMBER	
				5e. TASK NUMBER	
				5f. WORK UNIT NUMBER	
7. PERFORMING ORGANIZATION NAME(S) AND ADDRESS(ES) <b>Lawrence Livermore National Laboratory P.O. Box 5508, L-494 Livermore, CA 94550</b>				8. PERFORMING ORGANIZATION REPORT NUMBER	
9. SPONSORING/MONITORING AGENCY NAME(S) AND ADDRESS(ES)				10. SPONSOR/MONITOR'S ACRONYM(S)	
				11. SPONSOR/MONITOR'S REPORT NUMBER(S)	
12. DISTRIBUTION/AVAILABILITY STATEMENT <b>Approved for public release, distribution unlimited</b>					
13. SUPPLEMENTARY NOTES <b>See also ADM002371. 2013 IEEE Pulsed Power Conference, Digest of Technical Papers 1976-2013, and Abstracts of the 2013 IEEE International Conference on Plasma Science. Held in San Francisco, CA on 16-21 June 2013. U.S. Government or Federal Purpose Rights License.</b>					
14. ABSTRACT					
15. SUBJECT TERMS					
16. SECURITY CLASSIFICATION OF:			17. LIMITATION OF ABSTRACT	18. NUMBER OF PAGES	19a. NAME OF RESPONSIBLE PERSON
a. REPORT <b>unclassified</b>	b. ABSTRACT <b>unclassified</b>	c. THIS PAGE <b>unclassified</b>			

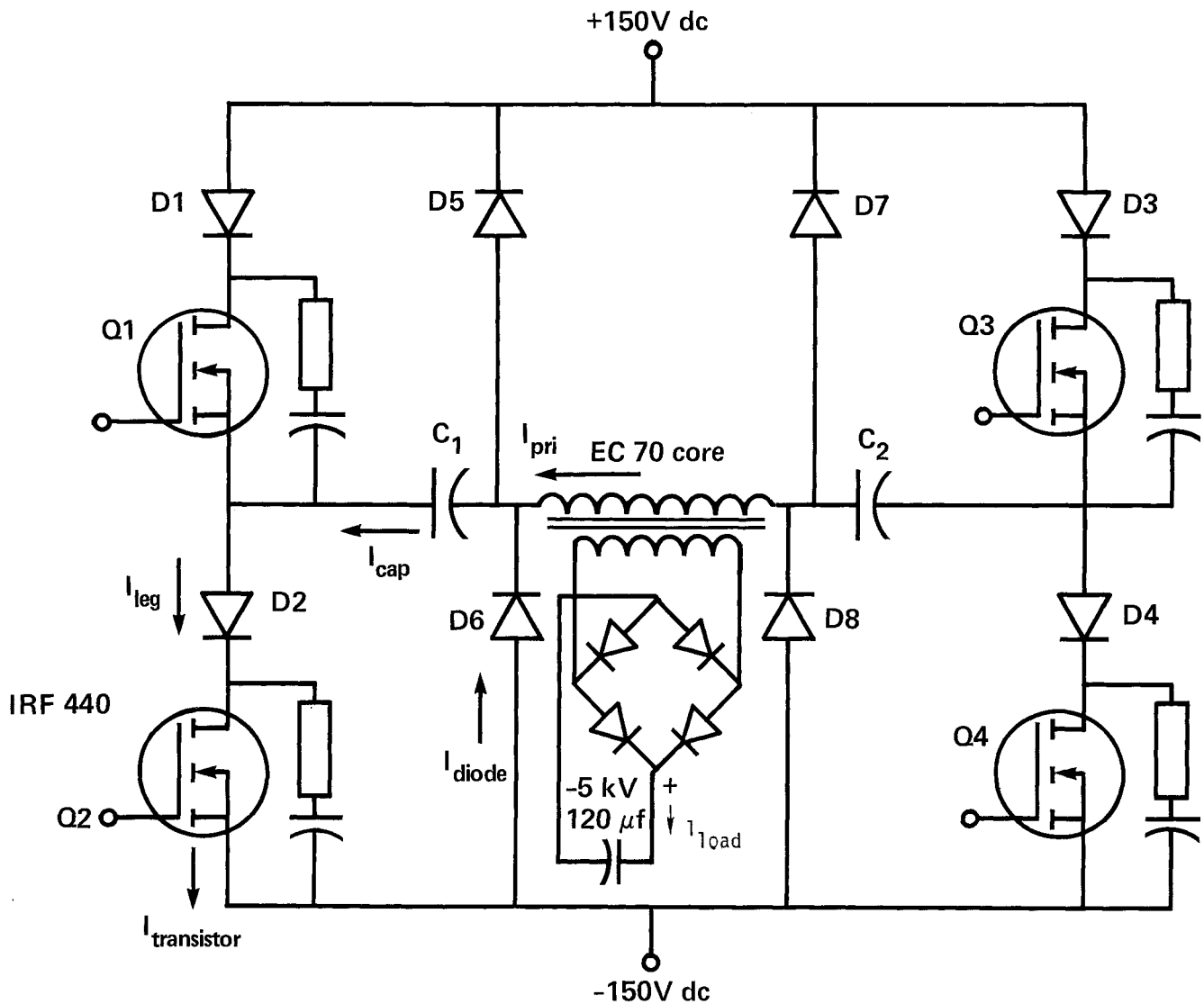

FIGURE 1

FULL BRIDGE POWER CIRCUIT

Waveforms

Refer to Figure 1 for the location and direction of some of the currents shown in the oscilloscope traces. Figure 2 shows, from top to bottom, transistor gate drive voltage, primary current, leg current of both phases, and load current all at some point before the capacitor is fully charged. When a phase is being driven, the gate drive voltage is low while the corresponding gate voltage is high. Positive primary current occurs just after the gate drive goes low. Deadtime between pulses is programmed at four microseconds to assure that no problems occur between the transition of positive and negative pulses, but as can be seen there is hardly a trace of actual deadtime for this particular case. Leg current follows primary current until it peaks after which it falls sharply to an exponential waveform that charges the transistor RC snubber circuit. The bottom trace shows that the load current does not start when primary current does. Instead, the secondary capacitance must charge up to a voltage that overcomes the capacitor voltage through the rectifiers. The load current then follows the primary current to zero.

Figure 3 shows primary, transistor and diode currents. Figure 4 shows leg, transistor and diode currents. Transistor current differs from leg current because it is the summation of leg and discharging snubber currents. The diode current in Figure 4 occurs when the opposite phase (Q1 and Q4) turns off. When Q2 is on primary current is in the direction shown and the transformer is biased positive from right to left. When the transistors are turned off the series diodes in the legs block any ringing or negative spikes and transistor current rapidly goes to zero. The diode remains on, however, to charge the snubber. As primary current falls di/dt reverses and the transformer voltage is now biased from left to right. This positively biases D5 and D8, so that current is not interrupted and stored transformer energy has a path to flow to charge the load.

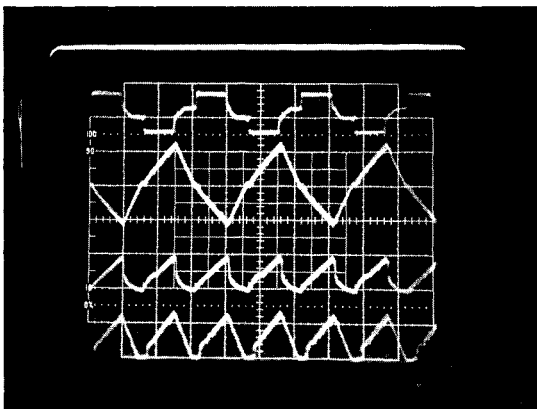

FIGURE 2

Drive Voltage 20V/div  
 $I_{pri}$  5A/div  
 $I_{legs}$  5A/div  
 $I_{load}$  200ma/div  
 10  $\mu$ S/div

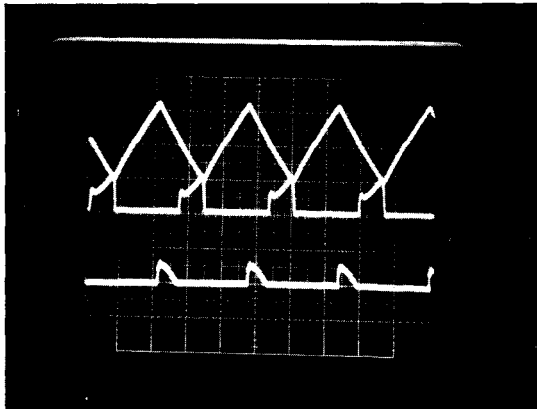

FIGURE 3

$I_{pri}$  5A/div  
 $I_{transistor}$  5A/div  
 $I_{diode}$  5A/div  
 10  $\mu$ S/div

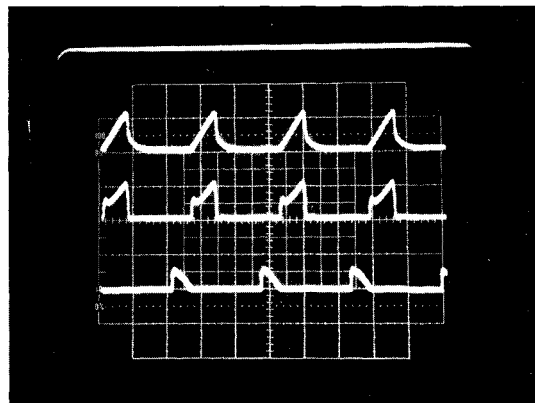

FIGURE 4

$I_{leg}$  5A/div  
 $I_{transistor}$  5A/div  
 $I_{diode}$  5A/div  
 10  $\mu$ S/div

The eight diodes in the full bridge configuration give the FET's turn off characteristics that are better than those of a comparable bipolar transistor. The fast recovery rectifier allows normal FET turn off of one microsecond, while the bipolar turn off is governed by the time required for the negative base bias to sweep the base-emitter junction, typically 3 - 5 microseconds. Figure 5 shows transistor drain-to-source voltage and transistor current. Switching losses are low as are the conduction losses and the snubbers effectively limit turn off spikes.

#### Regulation

A high gain differential amplifier in the feedback loop gives the power supply exceptional regulation characteristics. At 5 Kv the regulation is +2 volts, or + 0.04 percent. Shown in Figure 6 is a digital signal called AT VOLTS that goes high when the set voltage has been reached, followed by primary current and load current, where the flashlamp supply is regulating at 2 kv. Packets of charging pulses occur at regular intervals, and Figure 6 shows these packets in detail at 500 microseconds/div. The controls are designed to soft start the supply during regulation by gradually increasing the pulse width over a period of 1.5 milliseconds. We see that AT VOLTS goes high briefly and falls again one millisecond after the packet starts. This causes the pulses to be reset and soft start all over again. At the end of 2.5 milliseconds AT VOLTS oscillates, causing a continual series of pulses that are the width of the first pulse in the soft start. Figure 7 shows this final stage in detail at 10 microseconds/div. Regulation occurs every other pulse and the full 4 microsecond deadtime between whole pulses can be seen.

The gain of 1,000 in our feedback loop and the ability to soft start the pulse packets results in excellent regulation anywhere from zero to 5 kv. In fact, the soft starting feature is what allows any voltage to be set initially; otherwise, the timed pulse widths would be too long when the packet starts, resulting in an overcurrent condition and shutting down the supply.

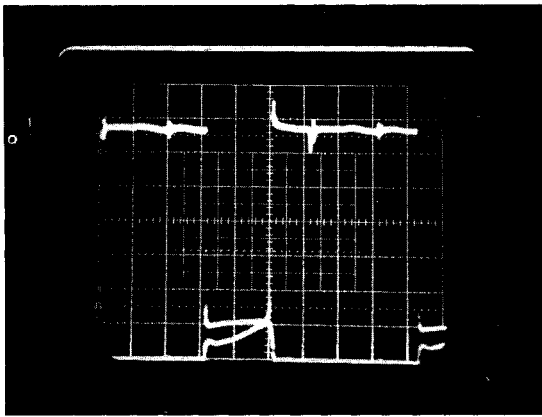

FIGURE 5

$V_{DS}$  50V/div  
 $I_{transistor}$  5A/div  
 5  $\mu$ s/div

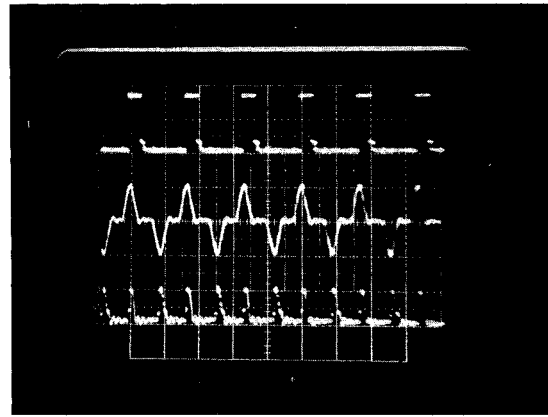

FIGURE 7

AT VOLTS 2V/div  
 $I_{pri}$  2A/div  
 $I_{load}$  100ma/div  
 10  $\mu$ s/div

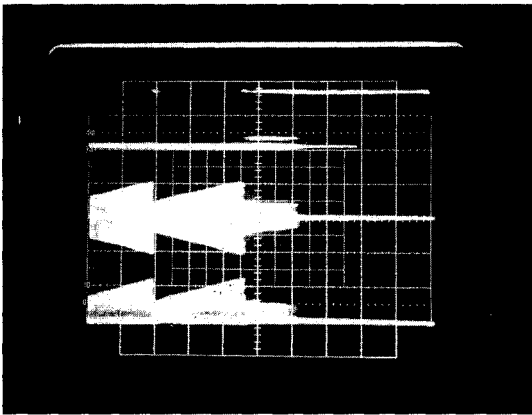

FIGURE 6

AT VOLTS 2V/div  
 $I_{pri}$  5A/div  
 $I_{load}$  200ma/div  
 500 $\mu$ s/div

Conclusion

Switching power supplies were designed and exceeded the requirements of the Nova 10 mm rod amplifiers. A full bridge with fast recovery diodes is used to improve FET turn off and improve efficiency. The leakage reactance of the transformer effectively limits current so that an inductor is not required. The pulse width is programmable, making them variable frequency power supplies, and may be controlled by a computer or other device for special loads. Higher power can be attained by using heftier transformers and transistors and going to a 480 Vac, 650 Vdc bridge.

References

1. "International Rectifier Hexfet Databook" and application guide, 1982-83.
2. "Designing With Operational Amplifiers", J. G. Graeme, McGraw-Hill, 1977.

DISCLAIMER

This document was prepared as an account of work sponsored by an agency of the United States Government. Neither the United States Government nor the University of California nor any of their employees, makes any warranty, express or implied, or assumes any legal liability or responsibility for the accuracy, completeness, or usefulness of any information, apparatus, product, or process disclosed, or represents that its use would not infringe privately owned rights. Reference herein to any specific commercial products, process, or service by trade name, trademark, manufacturer, or otherwise, does not necessarily constitute or imply its endorsement, recommendation, or favoring by the United States Government or the University of California. The views and opinions of authors expressed herein do not necessarily state or reflect those of the United States Government thereof, and shall not be used for advertising or product endorsement purposes.