

BLACKSTONE RIVER FLOOD-CONTROL PROJECT AT WOONSOCKET, RHODE ISLAND

Hydraulic Model Investigation



TECHNICAL REPORT NO. 2-468

December 1957

U. S. Army Engineer Waterways Experiment Station
CORPS OF ENGINEERS
Vicksburg, Mississippi

Report Documentation Page

Form Approved
OMB No. 0704-0188

Public reporting burden for the collection of information is estimated to average 1 hour per response, including the time for reviewing instructions, searching existing data sources, gathering and maintaining the data needed, and completing and reviewing the collection of information. Send comments regarding this burden estimate or any other aspect of this collection of information, including suggestions for reducing this burden, to Washington Headquarters Services, Directorate for Information Operations and Reports, 1215 Jefferson Davis Highway, Suite 1204, Arlington VA 22202-4302. Respondents should be aware that notwithstanding any other provision of law, no person shall be subject to a penalty for failing to comply with a collection of information if it does not display a currently valid OMB control number.

1. REPORT DATE DEC 1957		2. REPORT TYPE		3. DATES COVERED 00-00-1957 to 00-00-1957	
4. TITLE AND SUBTITLE Blackstone River Flood-control Project at Woonsocket, Rhode Island: Hydraulic model Investigation				5a. CONTRACT NUMBER	
				5b. GRANT NUMBER	
				5c. PROGRAM ELEMENT NUMBER	
6. AUTHOR(S)				5d. PROJECT NUMBER	
				5e. TASK NUMBER	
				5f. WORK UNIT NUMBER	
7. PERFORMING ORGANIZATION NAME(S) AND ADDRESS(ES) U.S. Army Corps of Engineers, Waterway Experiment Station, 3903 Halls Ferry Road, Vicksburg, MS, 39180				8. PERFORMING ORGANIZATION REPORT NUMBER	
9. SPONSORING/MONITORING AGENCY NAME(S) AND ADDRESS(ES)				10. SPONSOR/MONITOR'S ACRONYM(S)	
				11. SPONSOR/MONITOR'S REPORT NUMBER(S)	
12. DISTRIBUTION/AVAILABILITY STATEMENT Approved for public release; distribution unlimited					
13. SUPPLEMENTARY NOTES					
14. ABSTRACT					
15. SUBJECT TERMS					
16. SECURITY CLASSIFICATION OF:			17. LIMITATION OF ABSTRACT	18. NUMBER OF PAGES	19a. NAME OF RESPONSIBLE PERSON
a REPORT unclassified	b ABSTRACT unclassified	c THIS PAGE unclassified			

PREFACE

A hydraulic model investigation of flood-control plans for the Blackstone River at Woonsocket Falls, Rhode Island, was authorized by the Division Engineer, U. S. Army Engineer Division, New England, in an indorsement dated 2 May 1956. The study was conducted in the Hydraulics Division of the Waterways Experiment Station during the period June to September 1956 under the supervision of Messrs. E. P. Fortson, Jr., G. B. Fenwick, and J. J. Franco by Messrs. J. E. Glover and Lloyd Woods.

During the course of the study, close liaison was maintained between the New England Division and the Waterways Experiment Station, chiefly through monthly progress reports, special reports, and visits. Results of tests on the model were submitted to the Division Engineer upon the completion of each test. Messrs. E. F. Childs, J. W. Lambie, J. C. Dingwall, and J. Degen of the New England Division visited the Experiment Station to observe the model in operation and to discuss test results.

CONTENTS

	<u>Page</u>
PREFACE	iii
SUMMARY	vii
PART I: INTRODUCTION	1
Location and Description of Prototype	1
Description of Past Floods	2
Design Flood	2
Flood Damages	3
Project Plan	3
Problem and Purposes of Model Study	3
PART II: THE MODEL	5
Description	5
Appurtenances	6
Adjustment	6
PART III: TESTS AND RESULTS	8
Test Procedure	8
Original Design	8
Plan A	10
Plan B	11
Special Tests	11
PART IV: CONCLUSIONS	13
TABLE 1	
PHOTOGRAPHS 1-21	
PLATES 1-9	

SUMMARY

A 1:50-scale model was used to study flood-control plans for a reach of the Blackstone River at Woonsocket, Rhode Island. Plans for this reach included channel improvement, replacement of the existing fixed-crest industrial dam, and excavation below and under an existing masonry arch bridge. The purposes of the study were to check the hydraulic performance of the proposed Woonsocket Falls Dam and approaches, determine the most effective treatment of rock excavation downstream of the dam and under the South Main Street bridge, and develop such design modifications as might be found desirable. The fixed-bed model reproduced a 2225-ft reach of the Blackstone River, the proposed new dam, and bridges in the reach.

It was determined from the investigation that the proposed design would result in less head loss below the dam and under the South Main Street bridge than had been computed, resulting in lower water-surface elevations upstream of the dam for the design discharge. The results also indicated that the rock excavation below the dam could be reduced without affecting water-surface elevations above the dam, and that the head losses between the dam and the bridge could be increased appreciably before flood stages upstream of the dam would be affected seriously.

BLACKSTONE RIVER FLOOD-CONTROL PROJECT AT
WOONSOCKET, RHODE ISLAND

Hydraulic Model Investigation

PART I: INTRODUCTION

Location and Description of Prototype

1. The Blackstone River basin lies in south central Massachusetts and northern Rhode Island (fig. 1). The main headwater tributary of the Blackstone River is Kettle Brook, which has its origin some seven miles northwest of the city of Worcester, Massachusetts.

Tatnuck Brook and Mill Brook join Kettle Brook in the southern part of Worcester to form the Blackstone River which flows in a southerly direction to its junction with the Providence River at Providence, Rhode Island. The watershed of the Blackstone River above the city of Woonsocket, Rhode Island, is an elongated

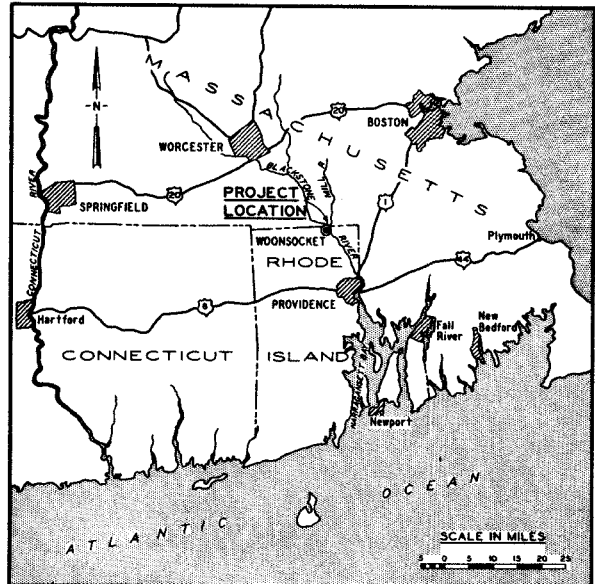

Fig. 1. Vicinity map

area of about 369 square miles, having a length of approximately 32 miles and an average width of 12 miles. The topography is generally hilly or rolling, with the higher elevations and narrower valleys in the western portion of the watershed. The Blackstone River basin is densely populated and extensively developed, primarily by industries. The area has a variable climate characterized by short periods of heavy precipitation. Three types of storms are common: cyclonic disturbances, coastal storms, and local thunderstorms.

2. The existing Blackstone River channel meanders through the city of Woonsocket and has a bankfull capacity of about 6000 cfs. The

Woonsocket Falls Dam, located within the city of Woonsocket, ponds water to el 148.1 ft msl to provide industrial-process water to mills along the river through a series of intakes and canals. The dam produces a back-water effect extending more than 2000 ft upstream. Three of the four bridges that formerly crossed the stream within the city of Woonsocket above the dam were destroyed or severely damaged during the 1955 flood. A large rock outcrop extends from the downstream face of the dam to the center pier of the double-arched South Main Street bridge, 100 ft downstream, separating the river into two discharge channels. The waterway openings of the bridge are restricted in area, which causes an increase in the tailwater and headwater elevations at the dam during flood flows.

Description of Past Floods

3. The greatest flood of record on the Blackstone River occurred in August 1955, and resulted in an estimated discharge at the Woonsocket Falls Dam of 26,000 cfs, almost twice the previous maximal discharge. The flood resulted from record rainfall accompanying "Hurricane Diane" falling on ground already saturated by precipitation from "Hurricane Connie" which had occurred only a few days earlier. In July 1938, March 1936, and November 1927 the Blackstone River experienced major floods of approximately half the magnitude of the August 1955 flood. Smaller floods occurred in September 1954 and October 1955.

Design Flood

4. The Standard Project Flood for the Blackstone River at Woonsocket has a peak discharge of 30,000 cfs, which will be equaled or exceeded only on rare occasions. This flood was derived by applying an adopted unit hydrograph to the Standard Project Storm (based on criteria described in Civil Works Engineer Bulletin No. 52-8) uniformly distributed over the Blackstone River watershed above the Woonsocket Falls Dam. The Standard Project Flood was adopted as the design flood for the structures of the flood-control project.

Flood Damages

5. The catastrophic flood of August 1955 caused extensive damage to the industrial property located along the river, destroyed one bridge, and damaged two others to such an extent that they were later removed. The average annual flood damage is estimated at nearly half a million dollars.

Project Plan

6. The Blackstone River flood-control project is designed to provide complete protection from flows equal to the maximum flood of record (26,000 cfs), but would permit some flooding of industrial plants and low areas adjacent to the channel during the Standard Project Flood (30,000 cfs). Channel improvements will start near the Massachusetts-Rhode Island state line and extend for approximately 8300 ft to just below the South Main Street bridge in the center of Woonsocket. The improved channel will provide as large a cross-sectional area as is physically and economically feasible and will be trapezoidal in shape with bottom widths varying from 92.5 to 120 ft, except that the approach to the dam has been flared to a bottom width of approximately 230 ft at the dam. Side slopes will vary from 1 on 1.5 to 1 on 2 in earth and will be 1 on 2 or 4 on 1 in rock. Short training walls will be constructed to transition into reaches where channel excavation is restricted by physical limitations such as buildings and other structures projecting into the floodway. The bottom grade of the improved channel will be 0.183 per cent for approximately 7600 ft, and will either be level or sloped upwards in its approach to the dam. The project will also include the replacement of the existing fixed-crest industrial dam, rock excavation between the toe of the dam and the South Main Street bridge to minimize submergence of the dam, the modification and reconstruction of highway and railroad bridges, and subaqueous utilities, and the construction of a pumping station, floodwalls, and dikes.

Problem and Purposes of Model Study

7. Because of the complexities in the design of the Blackstone

River improvements at Woonsocket due to physical limitations on channel alignment, and also because of the difficulties involved in determining by analytical means the hydraulic effectiveness of various proposals for the improvement of the reach, it was considered desirable to determine the optimum design for the critical reach near the dam by model tests. The specific purposes of the model study were: (a) to check the design of the new Woonsocket Falls Dam and determine the most effective plan of rock excavation just downstream of the dam and under the South Main Street bridge; (b) to determine the head losses in the reach above the dam and the adequacy of the proposed alignment and cross-sectional area of the channel upstream of the dam; and (c) to determine the capacity of the openings under the South Main Street bridge.

PART II: THE MODEL

Description

8. The model reproduced a 2225-ft reach of the Blackstone River in the city of Woonsocket near the lower end of the flood-control project. It was of the fixed-bed type with the channel and floodway molded of sand-cement mortar to female sheet-metal templets (fig. 2). Piers for the Pascoag Branch Railroad bridge and for the Woonsocket Falls Dam were fabricated of wood. The South Main Street bridge and the Woonsocket Falls Dam were constructed of sheet metal. Buildings and other structures within the floodway areas were constructed of sand-cement mortar. As constructed, the model reproduced the originally proposed design for the reach.

9. The model was built to an undistorted linear scale of 1:50, model

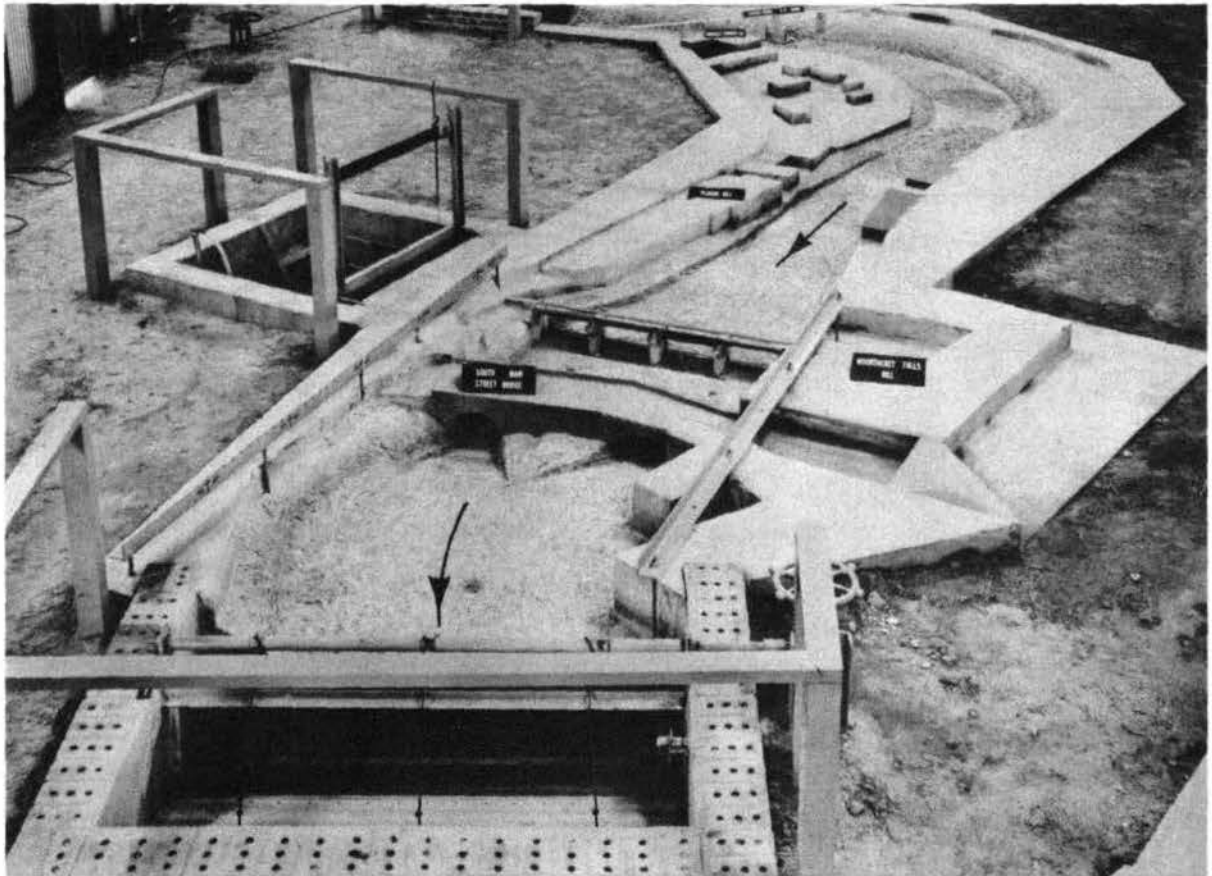

Fig. 2. General view of model

to prototype. Other scale ratios resulting from this linear scale ratio were: area 1:2500; discharge 1:17,677.5; velocity and time 1:7.07; and roughness (Manning's "n") 1:1.92. Measurements of discharges, water-surface elevations, velocities, and current directions can be transferred quantitatively from model to prototype equivalents by means of these relationships.

Appurtenances

10. Water was supplied to the model from a comprehensive circulating system and was measured with a venturi meter. Water-surface elevations at critical points along the channel were measured by means of piezometers located within the model channel and run to a centrally located gage pit; water-surface elevations at other points within the problem area were measured by means of a portable point gage supported on machined angle-iron rails installed for that purpose. Pressures over the dam were measured by means of piezometers on the crest run to the central gage pit. The tailwater elevation was controlled by an adjustable tailgate located at the downstream end of the model. Current velocities were measured with a pitot tube.

Adjustment

11. Inclusion of the proposed channel improvements in the initial model construction precluded adjustment of the model to existing prototype conditions. This type of adjustment was not considered necessary since the proposed improvements would involve radical changes from existing conditions. The model was adjusted to reproduce the furnished prototype roughness values used in the theoretical computations upon which the original design of channel improvements had been based. The prototype roughness value (Manning's "n") furnished by the New England Division was 0.035 for the excavated channel. To compensate for the effect of debris a roughness value of 0.035 was selected for the sides and arches of the South Main Street bridge.

12. The derived value of roughness was incorporated into the model

during construction and was based upon roughness standards developed from tests conducted by the Waterways Experiment Station.* Light stucco was used to reproduce roughness on the concrete portion of the model and expanded metal was used to reproduce the roughness of the South Main Street bridge (photographs 3 and 4).

13. Before tests on the model were started the Woonsocket Falls Dam was calibrated and the roughness coefficient of the reach upstream of the dam was checked. Calibration of the dam was accomplished by using only the two center bays, the center pier between these two bays, and half of each of the two adjacent side piers; guide vanes normal to the axis of the dam were used to eliminate the effect of uneven distribution of flow. This calibration indicated the discharge coefficient of the dam, including the effect of pier contraction, to be 3.78; this compares favorably with the design coefficient, without the effect of pier contraction, of 3.84. The model roughness upstream of the dam corresponded to an average prototype roughness factor (Manning's "n") of about 0.038. Since this roughness included bend losses and was on the high side of the design roughness of 0.035, it was considered satisfactory.

* Corps of Engineers, Waterways Experiment Station, Roughness Standards for Hydraulic Models: Report No. 1, Study of Finite Boundary Roughness in Rectangular Flumes. Technical Memorandum No. 2-364, Vicksburg, Miss. (June 1953).

PART III: TESTS AND RESULTS

Test Procedure

14. Model tests were concerned with losses in the reach above Woonsocket Falls Dam, the distribution of flow over the dam, the adequacy of excavation under the South Main Street bridge to pass the design flood, and the development of plans to overcome any undesirable condition noted during the tests. Since the study was concerned principally with flood flows, all tests were conducted with constant flows and with dam crest gates open. The desired flows were introduced at the upper end of the model (project channel station 63+70) and tailwater elevations were maintained at sta 84+71 in accordance with a discharge rating curve furnished by the New England Division (plate 4).

15. Data obtained during the model study consisted of inflow measurements, water-surface elevations at critical points, water-surface profiles along the center line of the channel, velocities and water-surface elevations at the spillway crest for determining flow distribution over the dam, pressure gradients over the spillway, visual observations, and photographic records of flow conditions.

Original DesignDescription

16. The features of the original design, shown in plates 1-3 and photographs 1-4, included the following:

- a. Channel improvements from sta 63+70 to just upstream of the dam. The alignment and cross section of this reach of channel were controlled by existing buildings and other structures rather than by hydraulic considerations, and of necessity involved varying channel sections and transitions.
- b. Modification of the Pascoag (Harrisville) Branch Railroad bridge including the construction of an additional span and the underpinning of the piers to meet the requirements of the increased cross-sectional area.
- c. Construction of a new dam consisting of four 50-ft gated spillway sections and a short nonoverflow section forming

the right abutment. The dam was designed to maintain the present pool elevation of 148.1 ft msl in order to make available process water for industrial plants during normal flow, and to provide lower headwater elevations during flood flows.

- d. Rock excavation downstream of the dam and under the South Main Street bridge to lower tailwater elevations at the dam by increasing the capacity of waterway openings of the bridge and directing flow through the openings more efficiently.

Results

17. The results of tests of the original design, shown in photographs 5-11 and plates 5 and 6, indicate head losses between the dam and the South Main Street bridge considerably less than those computed, resulting in a headwater elevation above the dam about 5 ft lower than that used in the backwater computations for the design discharge. Because of the higher velocities, caused by the lowering of stages, head losses through the reach from just above the Pascoag Railroad bridge (sta 65+50) to the dam were greater than those computed, so that stages just above the bridge were only about 2.5 ft lower than the computed elevation.

18. Changes in the alignment of the channel and side-wall transitions necessitated by buildings and structures projecting into the floodway produced transverse waves within the channel upstream of the dam (photograph 6). Disturbances were also caused by the Pascoag Railroad bridge piers which are not aligned with the flow, and by the rectangular-shaped underpinning of the piers (photograph 5). Flow distribution over the dam was affected by the alignment of the channel and short transition upstream of the dam. Surface currents from upstream were concentrated toward the two center bays of the dam with the bottom currents moving toward the end bays (photograph 7). The distribution of flow over the dam with design discharge was 23, 31, 28, and 18 per cent of the total for bays 1, 2, 3, and 4, respectively, starting at the left or east end. Because of the greater capacity of the west arch of the South Main Street bridge and the lower discharge through the two bays on the west side of the dam, water-surface elevations in the west channel between the dam and the bridge were generally lower than in the east channel. With discharges of 30,000 cfs and greater some flow crossed from the east

to the west channel over the rock outcrop above the bridge. Below the bridge flow did not follow the originally designed flare in the excavated channel downstream of each arch.

19. The maximum discharge that could be passed under the South Main Street bridge without overtopping was 42,600 cfs. Even with this discharge, control of the water-surface elevation above the dam did not pass from the dam to the bridge (plate 5). The results of pressure measurements over the dam obtained near the center of the second bay from the left are shown in plate 6. These measurements were obtained for use of the design engineers in checking the structural stability of the dam.

Plan A

Description

20. The results of the test of the original design indicated that flow through the arches of the South Main Street bridge would not follow the flare in the excavated channels downstream and that the amount of excavation could probably be reduced. Plan A included the reduction in the flare of the left bank of the channel below the west arch from 35 degrees to 15 degrees and a reduction in the amount of rock excavation at the upper end of the island between the South Main Street bridge and the dam (photographs 12 and 13 and plate 7). The flare in the channel below the east arch was not changed since it was determined that excavation of this channel in the prototype was almost completed at the time tests were undertaken. Although the results of the test of the original design indicated disturbances in flow upstream of the dam, tests of modifications of the plan for that reach were not considered necessary for the following reasons:

- a. The capacity of the channel was found to be adequate due to the lower headwater elevation at the dam.
- b. Modifications that could be made would be minor since the design of the channel was controlled to a large extent by existing structures.
- c. Design of modifications would have required a detailed investigation of foundation conditions at each structure. Also, since the original design was considered the most economical from a construction standpoint, other plans for the proposed dam were not tested.

Results

21. The results of the test of plan A are shown in photographs 14-17 and plate 9. With the design flow the reduction in the rock excavation of this plan caused an increase in water-surface elevation just downstream of the dam (below the jump) of about 0.7 ft and 0.5 ft for the east and west channels, respectively, without affecting the head-water elevation above the dam. Stages immediately upstream of the South Main Street bridge were raised about 0.2 ft at the east arch and lowered about 0.1 ft at the west arch. Below the bridge, water-surface elevations were raised about 0.1 ft at the east arch and lowered about 0.3 ft at the west arch. The difference in the effect produced in the east and west channels is attributable mostly to the change in the amount of flow from the east to the west channel caused by the reduction in rock excavation at the head of the island. The reduction in the rock excavation did not affect the maximum flow that could be passed under the bridge.

Plan B

Description

22. Plan B was the same as plan A except that the flare in the left bank was reduced to 10 degrees (photograph 18 and plate 8).

Results

23. The results of the test of plan B, shown in photographs 19-21 and plate 9, indicate that changing the flare in the channel downstream of the west arch from 15 degrees to 10 degrees had no appreciable effect on flow conditions.

Special Tests

Description

24. Special tests were conducted to determine the effects on water-surface elevations above the dam of an increase in the head loss between the dam and bridge that might be caused by a surface roughness greater than that estimated or by the accumulation of debris. These tests were conducted under plan B conditions. The head losses were simulated by

raising the tailwater elevation until the headwater elevation was affected, and by raising the tailwater elevation until the water-surface elevation at the upstream end of the model was affected.

Results

25. The results of the special tests, shown in table 1, indicate that the head losses between the dam and the South Main Street bridge could be increased by 3.0 ft before the water-surface elevation at gage 1 (sta 65+50) would be affected with flows of 30,000 and 35,000 cfs and by 1.8 ft with a flow of 40,000 cfs. With the design flow the head loss below the dam could be increased by 1.5 ft before the water-surface elevation immediately above the dam (gage 4) would be affected. With the 35,000- and 40,000-cfs flows, the water-surface elevation just upstream of the dam would be affected by a small increase in the head loss below the dam.

PART IV: CONCLUSIONS

26. Model tests of the reach of the Blackstone River in the vicinity of the Woonsocket Falls Dam indicate that the original design would provide adequate protection against the design flood.

27. Other conclusions drawn from the results of the model study are summarized as follows:

- a. Headwater elevation above the dam for the design flood will be about 5 ft lower than that used in design computations, with a lowering of about 2.5 ft above the Pascoag Branch Railroad bridge.
- b. Head losses below the dam would have to be increased appreciably before the water-surface elevation above the dam would be affected.
- c. The maximum discharge that can be passed under the South Main Street bridge is about 42,600 cfs. Control of the water-surface elevation above the dam will not pass from the dam to the bridge without overtopping the bridge.
- d. The amount of rock excavation below the dam can be reduced without affecting stages upstream of the dam.

28. The design of the improvement plan within the reach was controlled to a large extent by existing structures and buildings projecting into the floodway. However, any improvement in the alignment of the banklines immediately upstream of the dam, such as elimination of the sharp angles along the Glenark Building, would tend to improve flow distribution over the dam and lower headwater elevations. Also, head losses and heights of the transverse waves within the reach upstream of the dam could be reduced by streamlining the underpinnings of the Pascoag Railroad bridge and by eliminating the sharp angles in the channel walls downstream of the bridge as much as possible. Final design of the channel as shown on the contract plans has since substituted steepened channel banks and training walls for the channel walls used in the model test and the underpinnings of the railroad bridge piers have been streamlined as much as practicable.

Table 1

Results of Tests with Simulated Head Losses
below Dam, Plan B Conditions

Gage*	Water-surface Elevations in ft msl								
	30,000 cfs			35,000 cfs			40,000 cfs		
	Base Test	Test 1	Test 2	Base Test	Test 1	Test 2	Base Test	Test 1	Test 2
1	154.1	154.1	154.3	156.0	156.0	156.2	158.0	158.1	158.2
2	153.0	153.2	153.5	155.1	155.0	155.3	157.2	157.3	157.5
3	150.8	150.9	151.2	152.5	152.5	152.9	154.5	154.6	155.0
4	147.0	147.3	148.0	147.9	149.0	150.5	150.2	151.1	152.1
Sta 80+42	148.5	148.9	149.2	150.2	150.4	151.5	152.8	152.8	153.8
5	145.7	147.1	148.3	148.2	149.5	150.8	151.3	152.1	153.0
6	144.5	146.2	147.7	147.0	148.7	150.6	150.7	151.6	152.6

Note: Base test conducted with design roughness and tailwater elevation.
 Test 1 conducted with head loss below dam increased. Increased head loss simulated by raising tailwater elevation (gages 5 and 6).
 Test 2 conducted with head loss below dam increased until water-surface elevation at gage 1 was affected.

* Gage locations shown in plate 1.

Photograph 1. Original improved channel design from upper end of modeled reach to about sta 70+50, including revised Pascoag Branch RR bridge

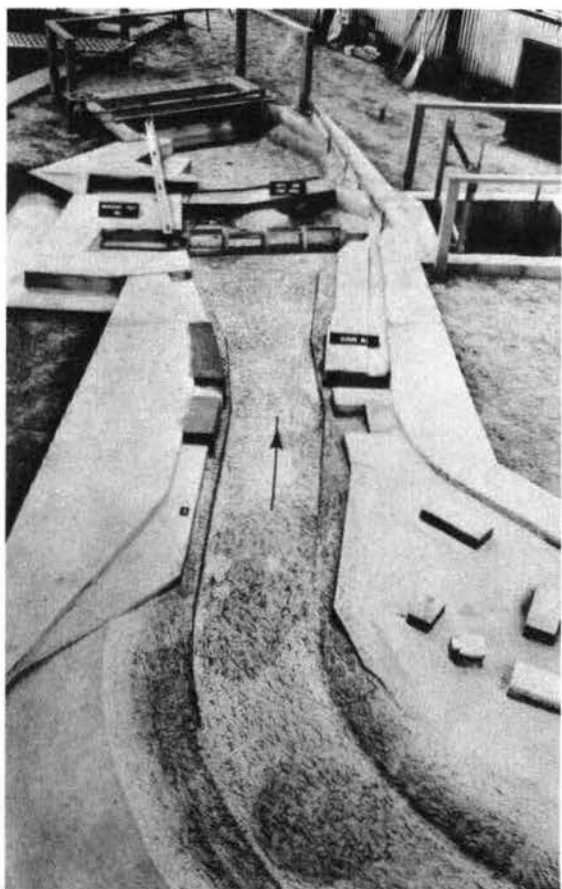
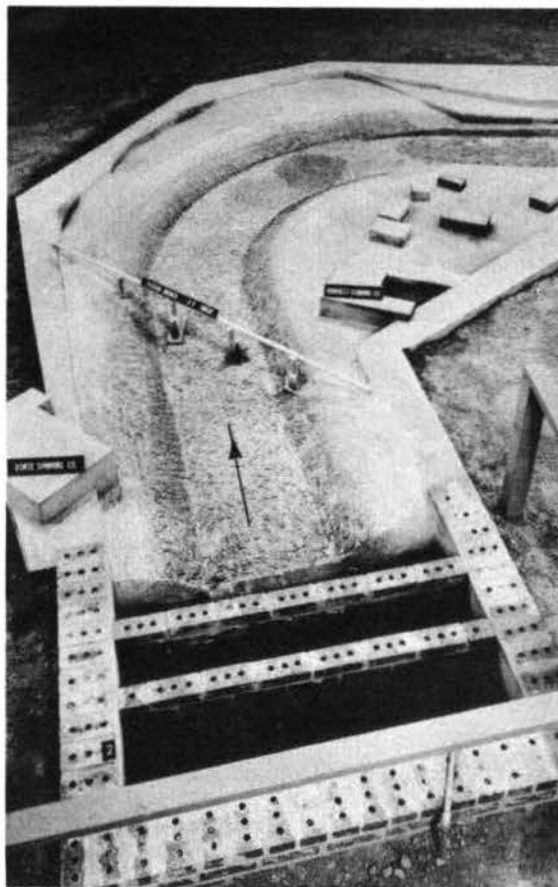

Photograph 2. Original improved channel design from about sta 70+50 to below South Main Street bridge



Photograph 3. Original design: Woonsocket Falls Dam and rock excavation between dam and South Main Street bridge



Photograph 4. Original design: Rock excavation below arches of South Main Street bridge

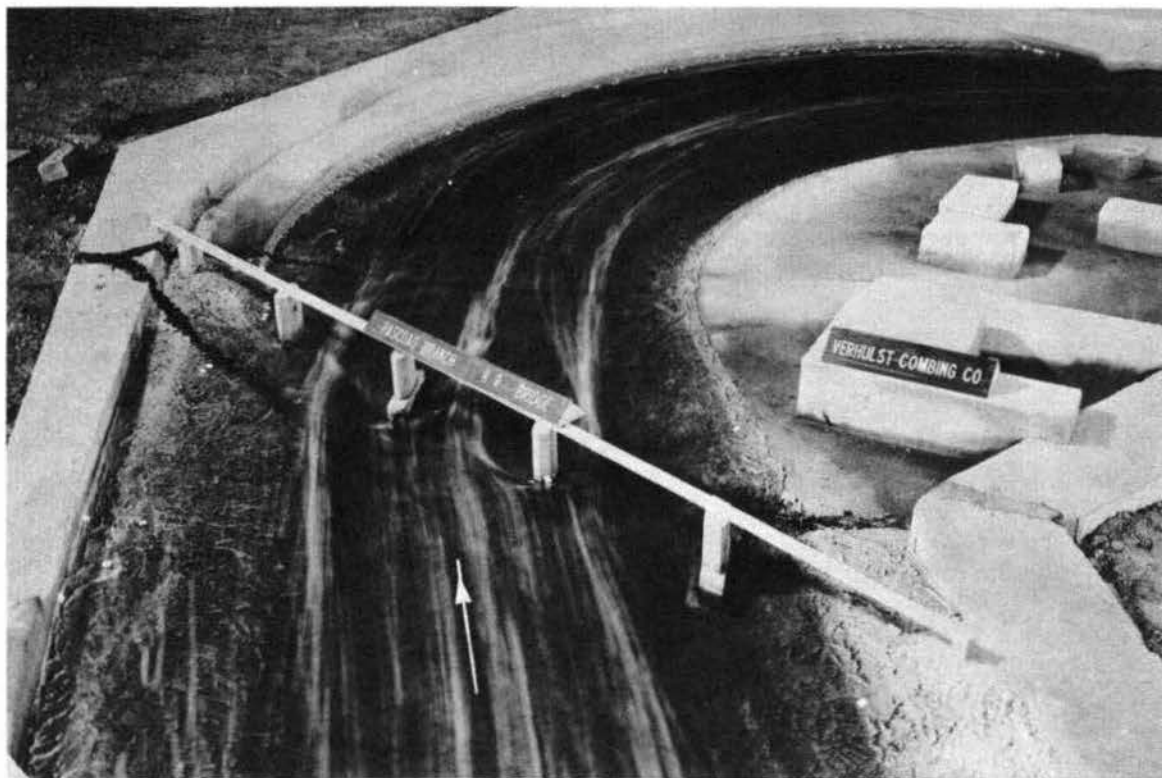

Photograph 5. Original design: Flow conditions in vicinity of Pascoag Branch Railroad bridge, discharge 30,000 cfs. Note disturbance in flow near bridge piers

Photograph 6. Original design: Flow conditions from about sta 72+00 to the Woonsocket Falls Dam, discharge 30,000 cfs. Note transverse waves caused by transitions in channel walls and by buildings projecting into floodway

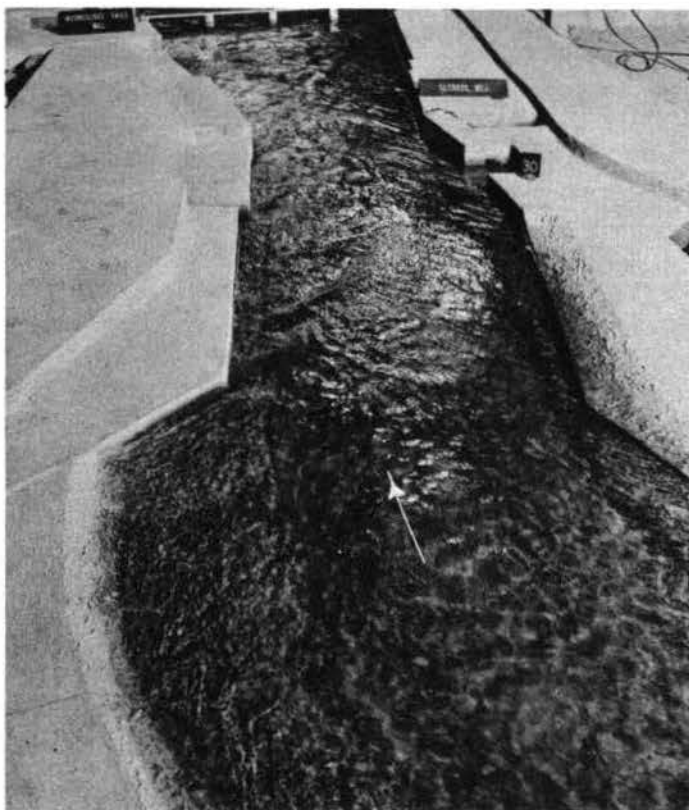



Photograph 7. Original design: Surface currents approaching Woonsocket Falls Dam, discharge 30,000 cfs. Note concentration of flow toward center bays

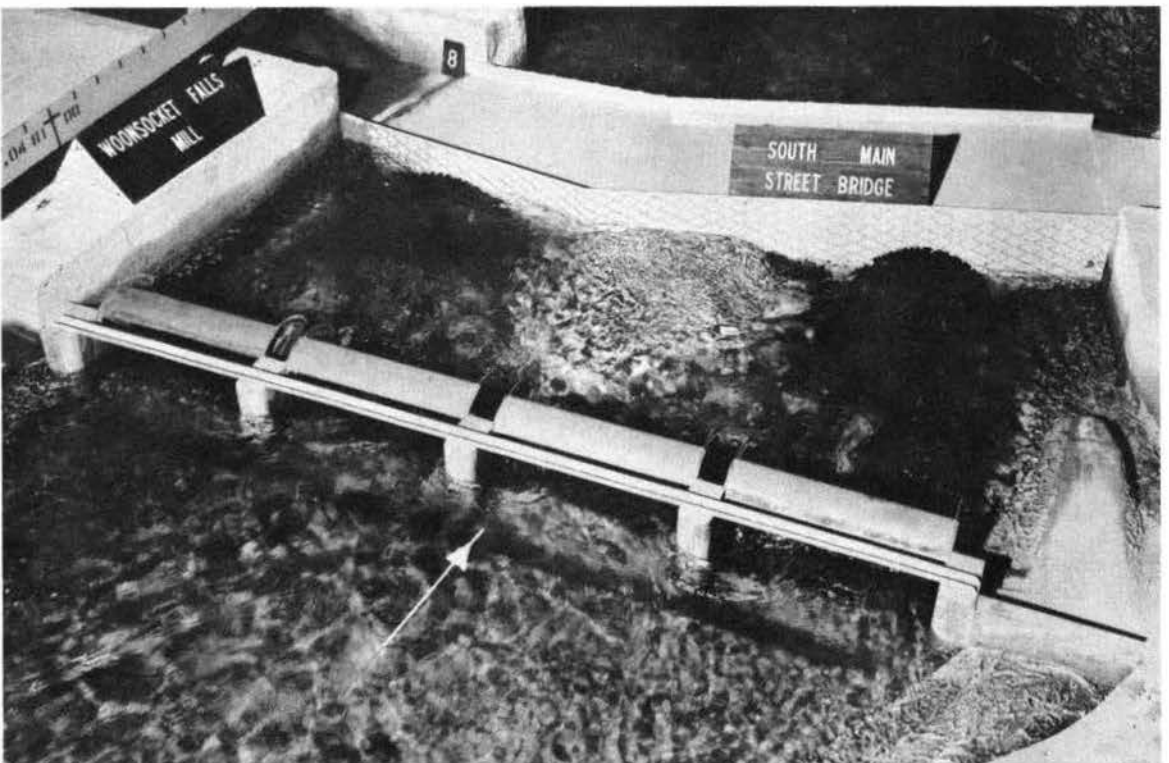

Photograph 8. Original design: Flow conditions between Woonsocket Falls Dam and South Main Street bridge, discharge 30,000 cfs

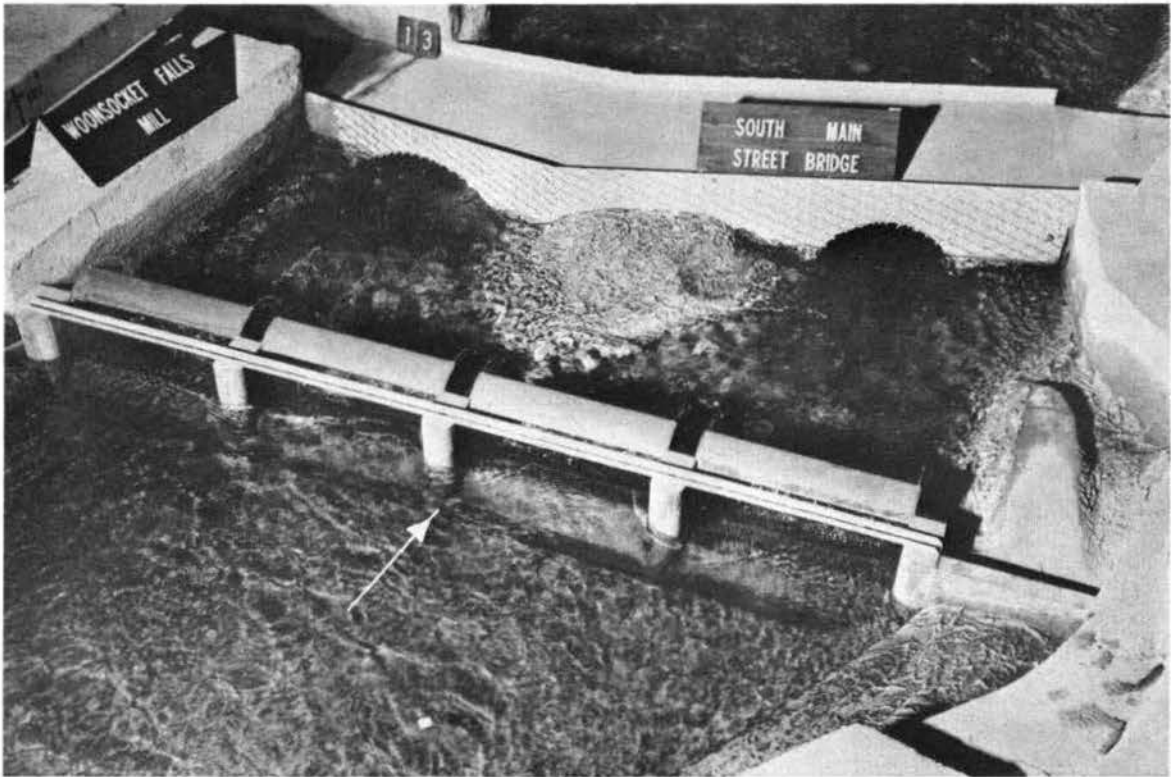

Photograph 9. Original design: Flow conditions between Woonsocket Falls Dam and South Main Street bridge, discharge 20,000 cfs

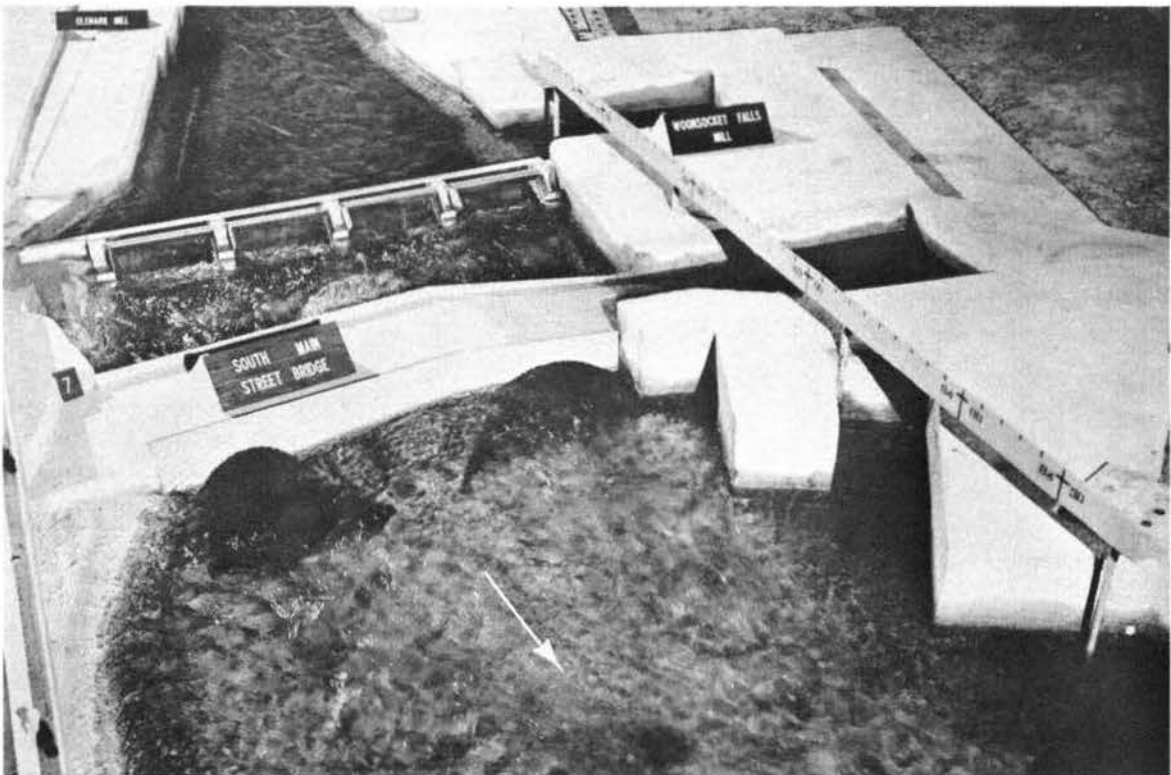

Photograph 10. Original design: Flow conditions below South Main Street bridge, discharge 30,000 cfs

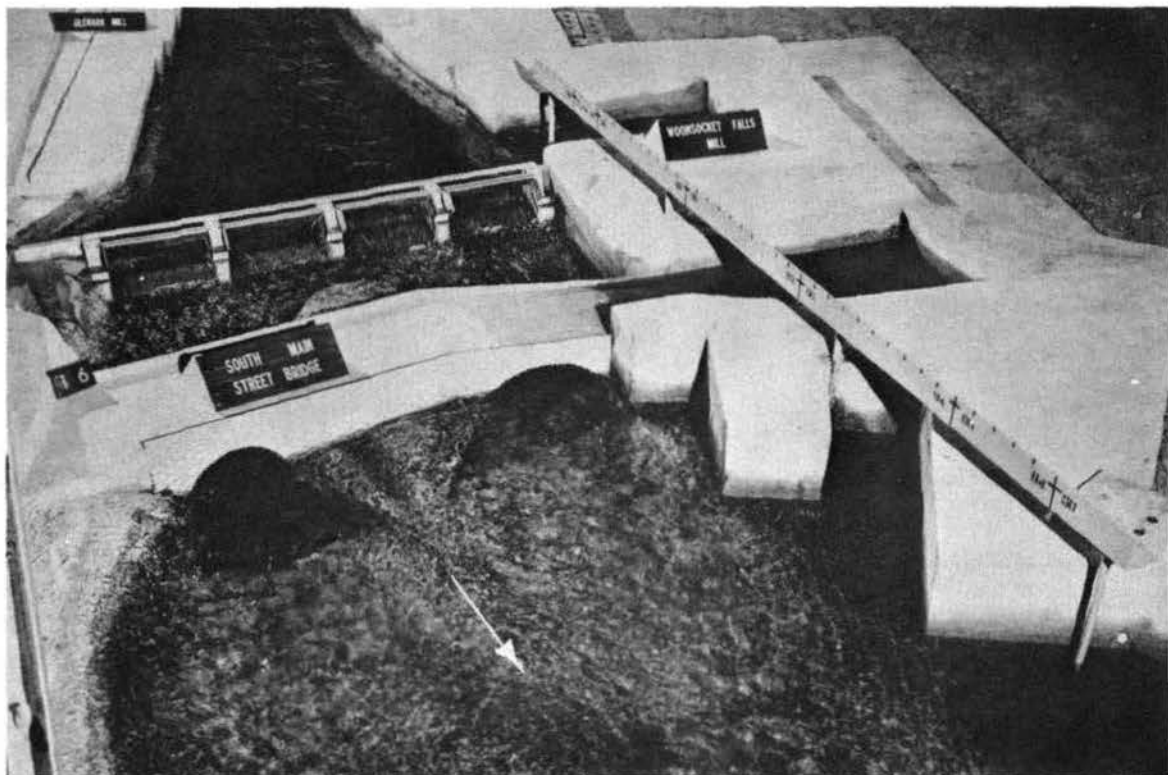

Photograph 11. Original design: Flow conditions below South Main Street bridge, discharge 20,000 cfs

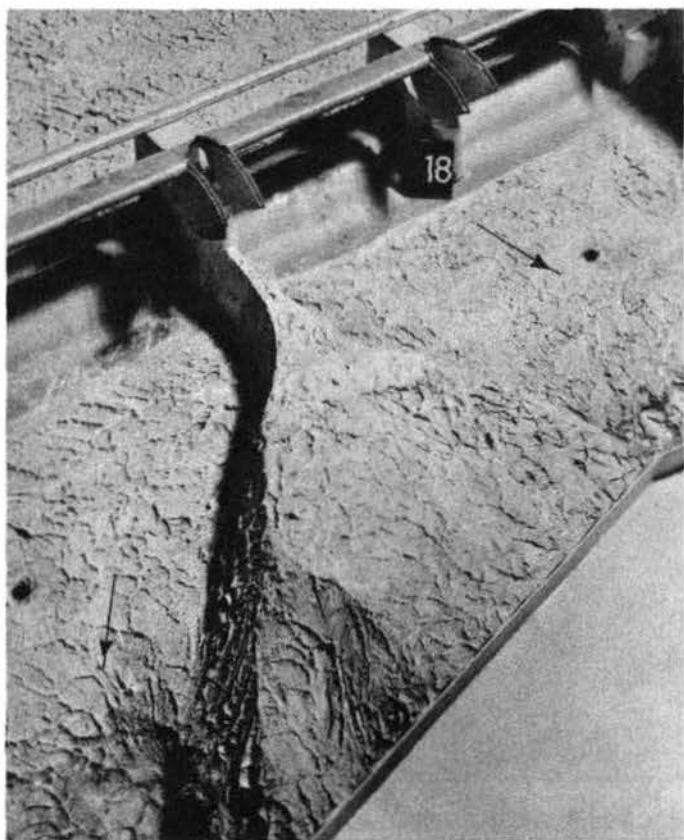

Photograph 12. Treatment of rock between Woonsocket Falls Dam and South Main Street bridge for Plan A. Compare with photograph 3

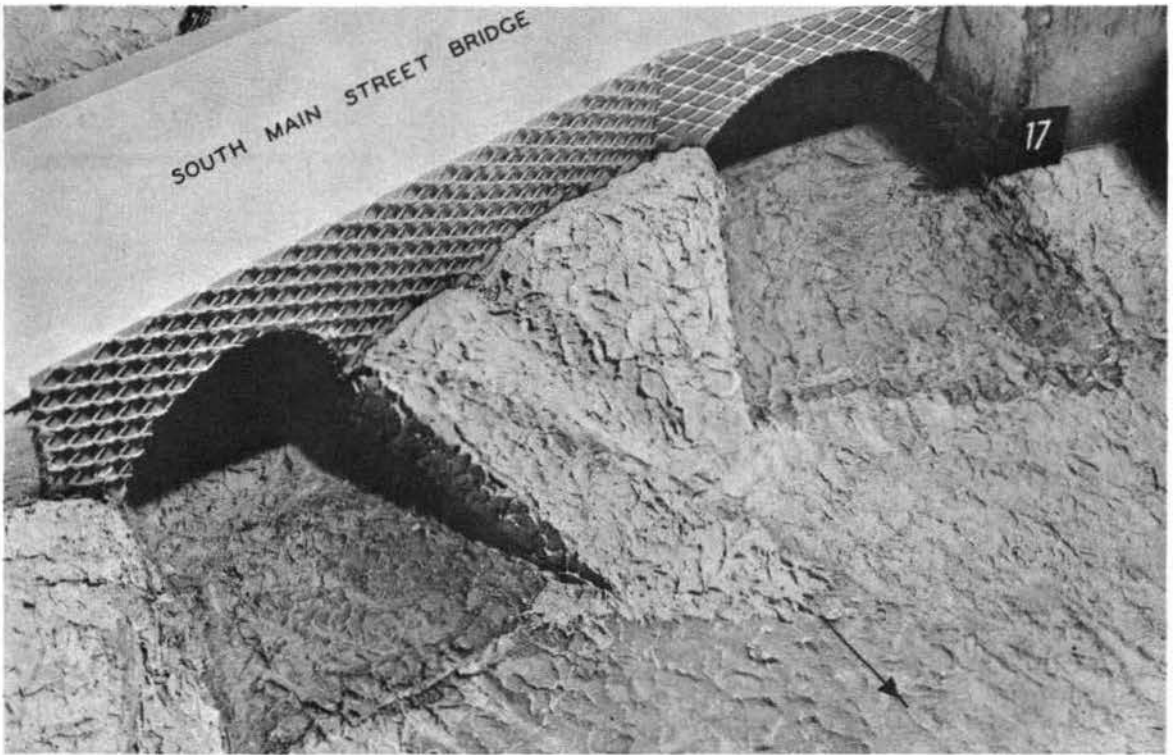

Photograph 13. Plan A: Rock excavation on the left side of the channel below the west arch of the South Main Street bridge with channel flare reduced to 15 degrees

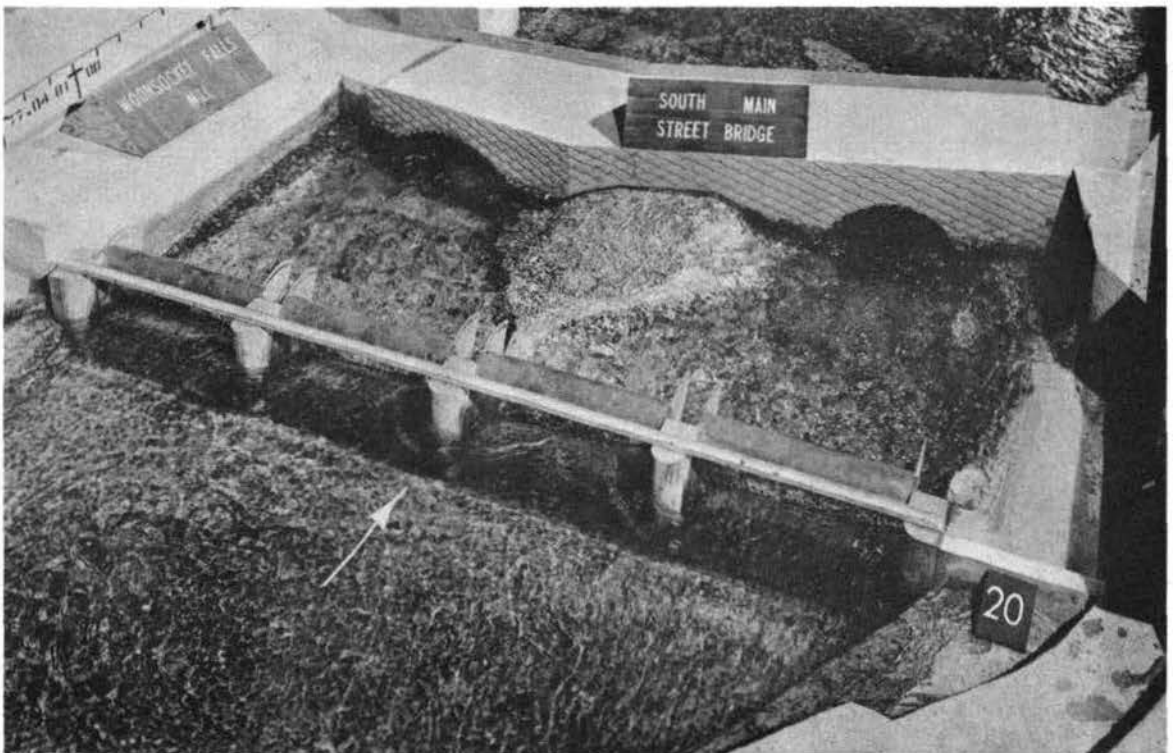

Photograph 14. Plan A: Flow conditions between Woonsocket Falls Dam and South Main Street bridge, discharge 20,000 cfs. Compare with photograph 9

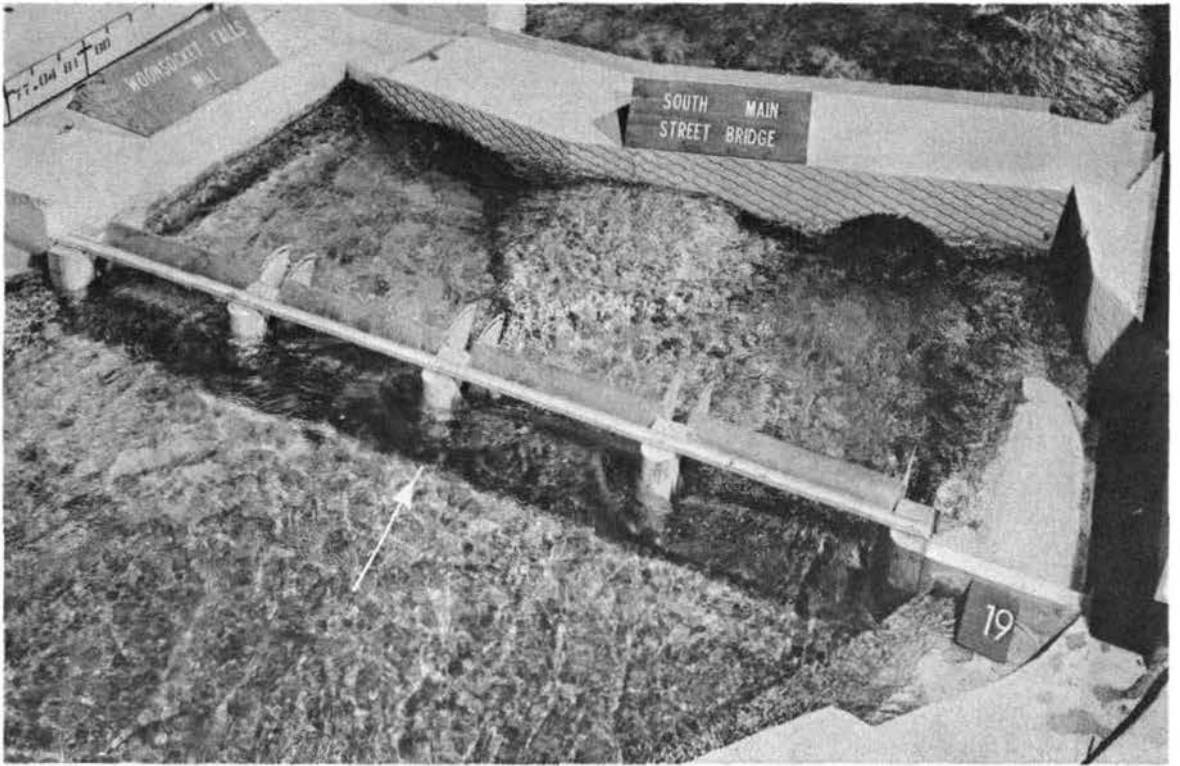

Photograph 15. Plan A: Flow conditions between Woonsocket Falls Dam and South Main Street bridge, discharge 30,000 cfs. Compare with photograph 8

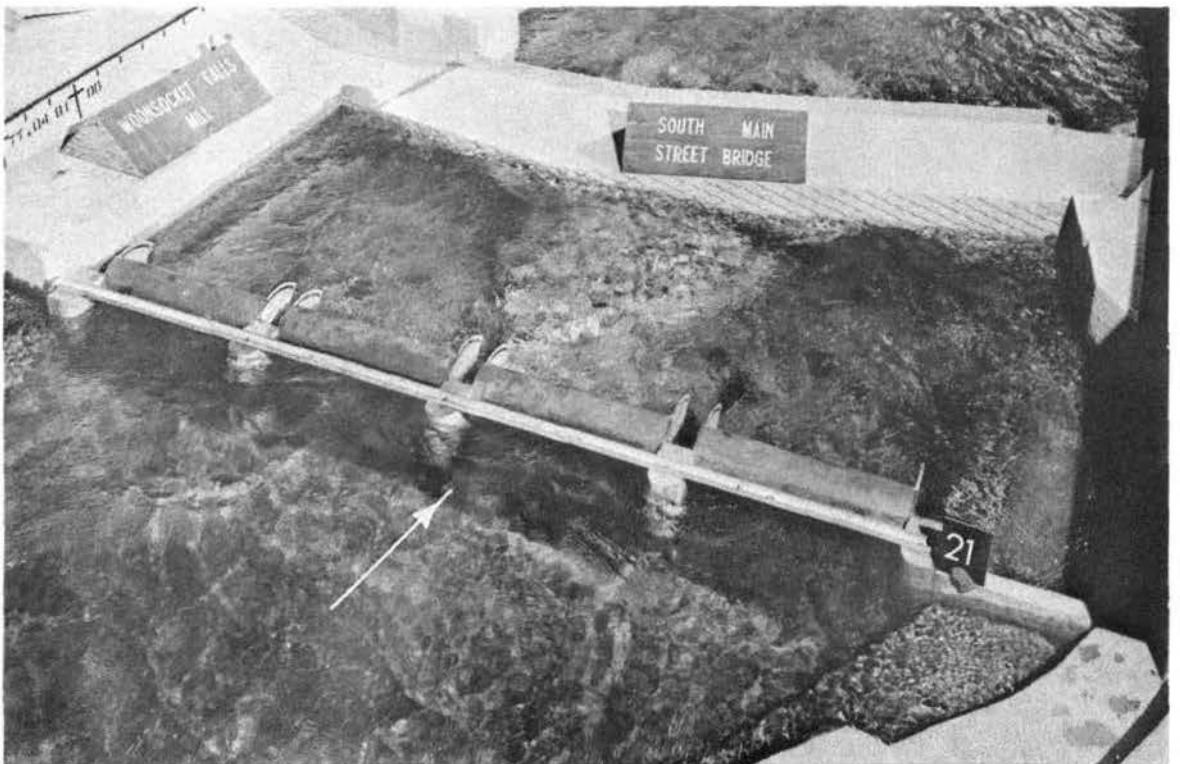

Photograph 16. Plan A: Flow conditions between Woonsocket Falls Dam and South Main Street bridge, discharge 42,600 cfs. Note water surface near top of bridge at left abutment

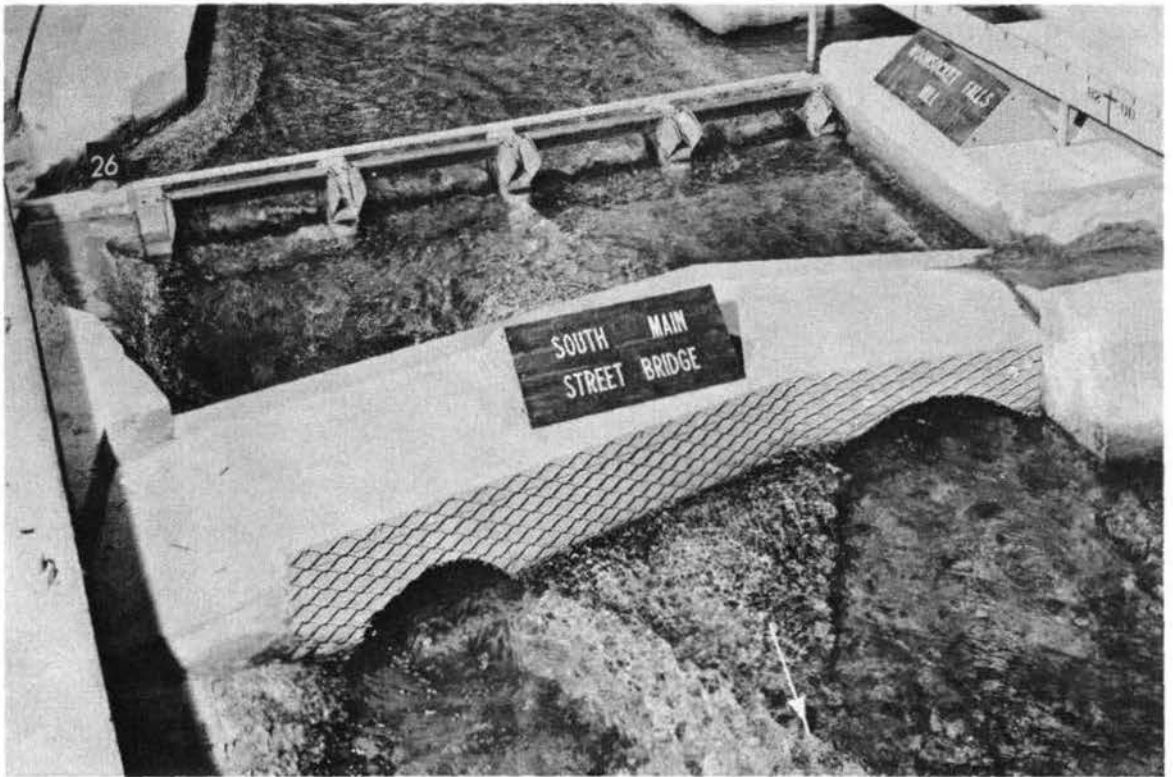

Photograph 17. Plan A: Flow conditions below South Main Street bridge, discharge 30,000 cfs



Photograph 18. Plan B: Rock excavation on left side of channel below the west arch of the South Main Street bridge with flare reduced to 10 degrees

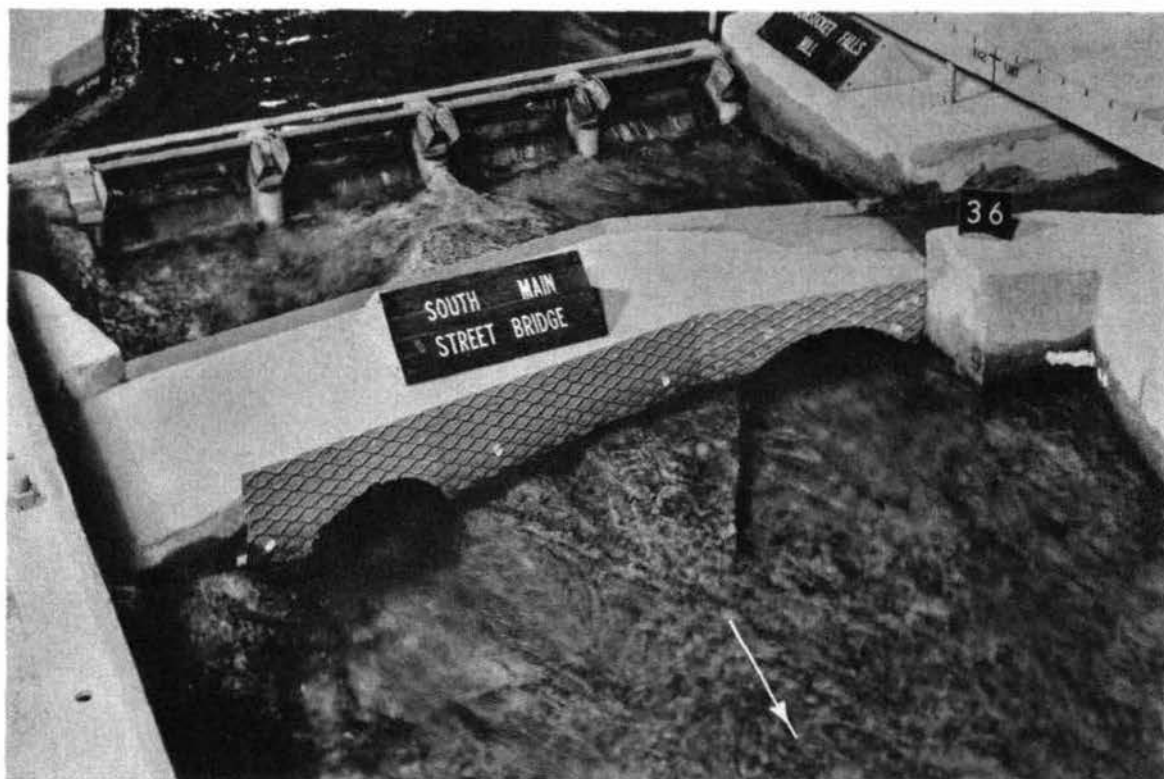

Photograph 19. Plan B: Flow conditions below South Main Street bridge, discharge 20,000 cfs

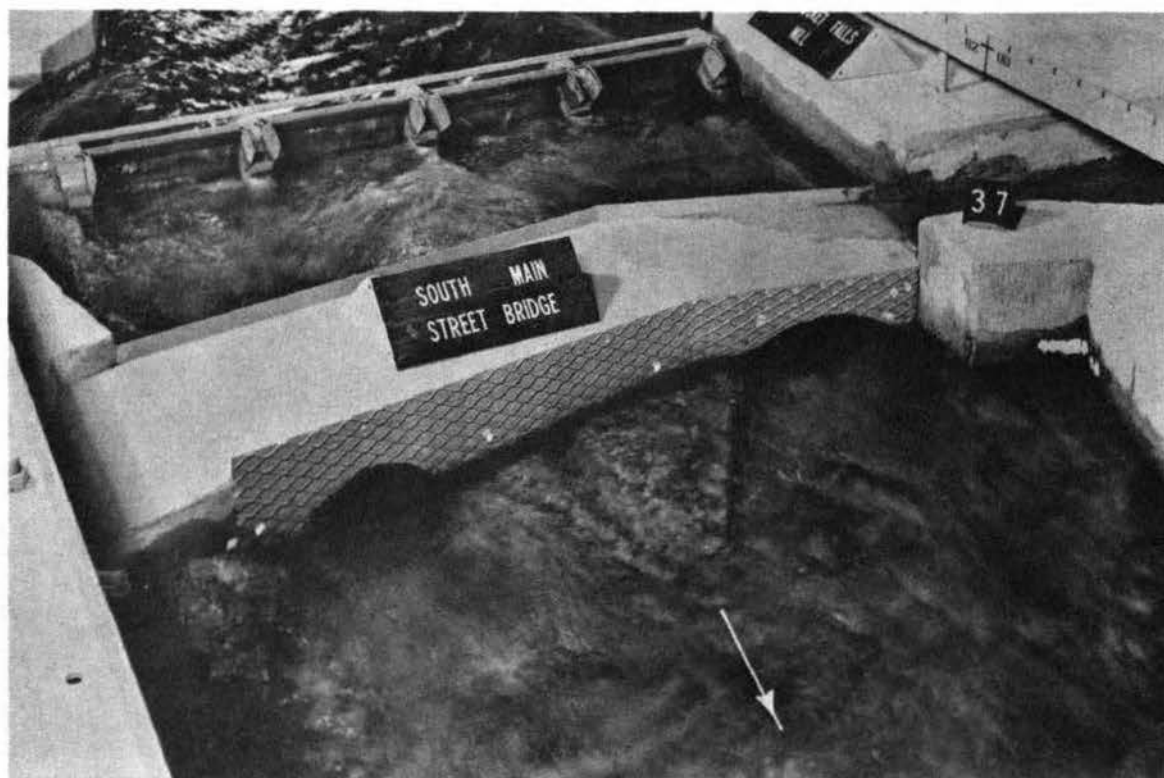

Photograph 20. Plan B: Flow conditions below South Main Street bridge, discharge 30,000 cfs

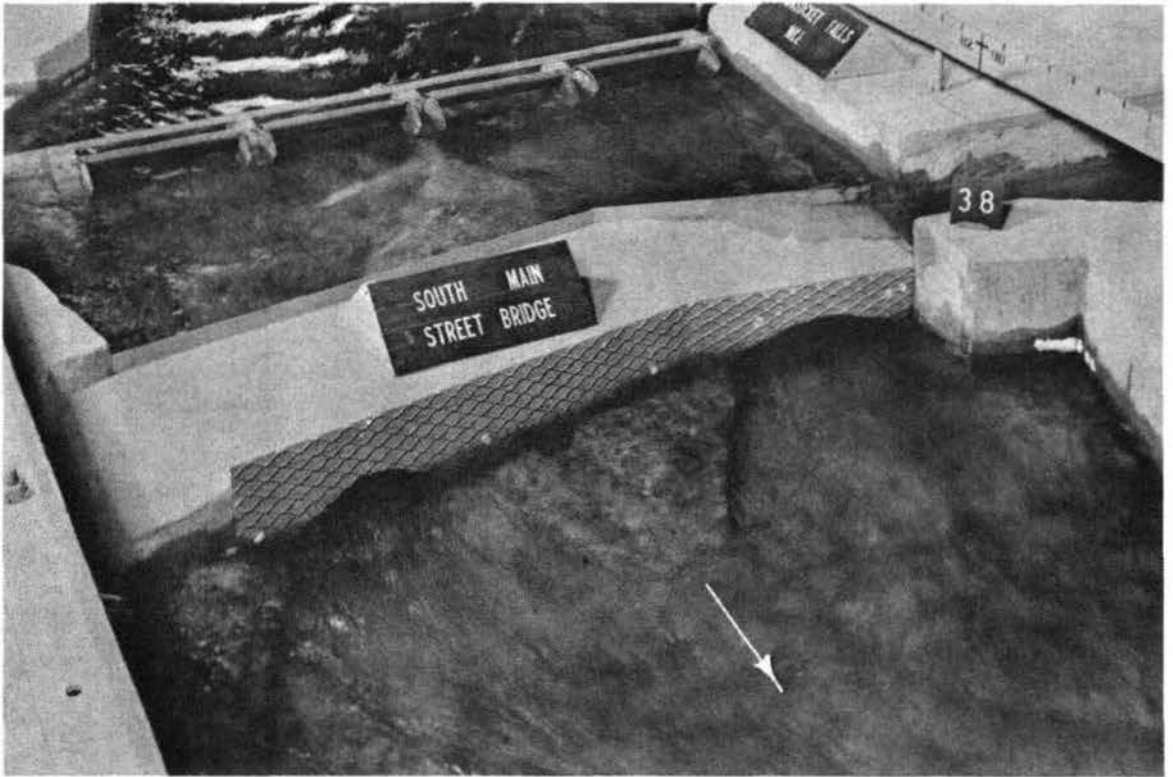

Photograph 21. Plan B: Flow conditions below South Main Street bridge, discharge 42,600 cfs

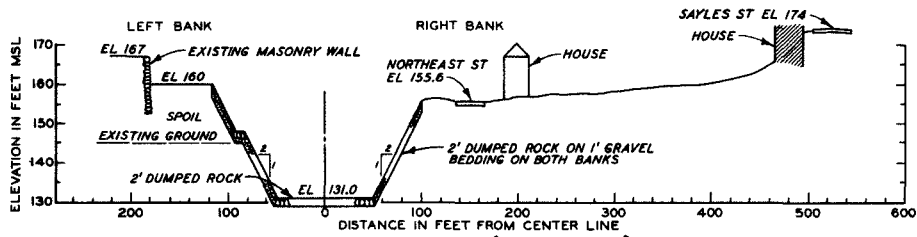

STA 70+50 (IN CURVE)

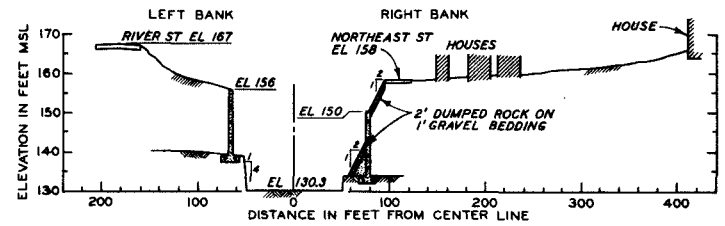

STA 74+50

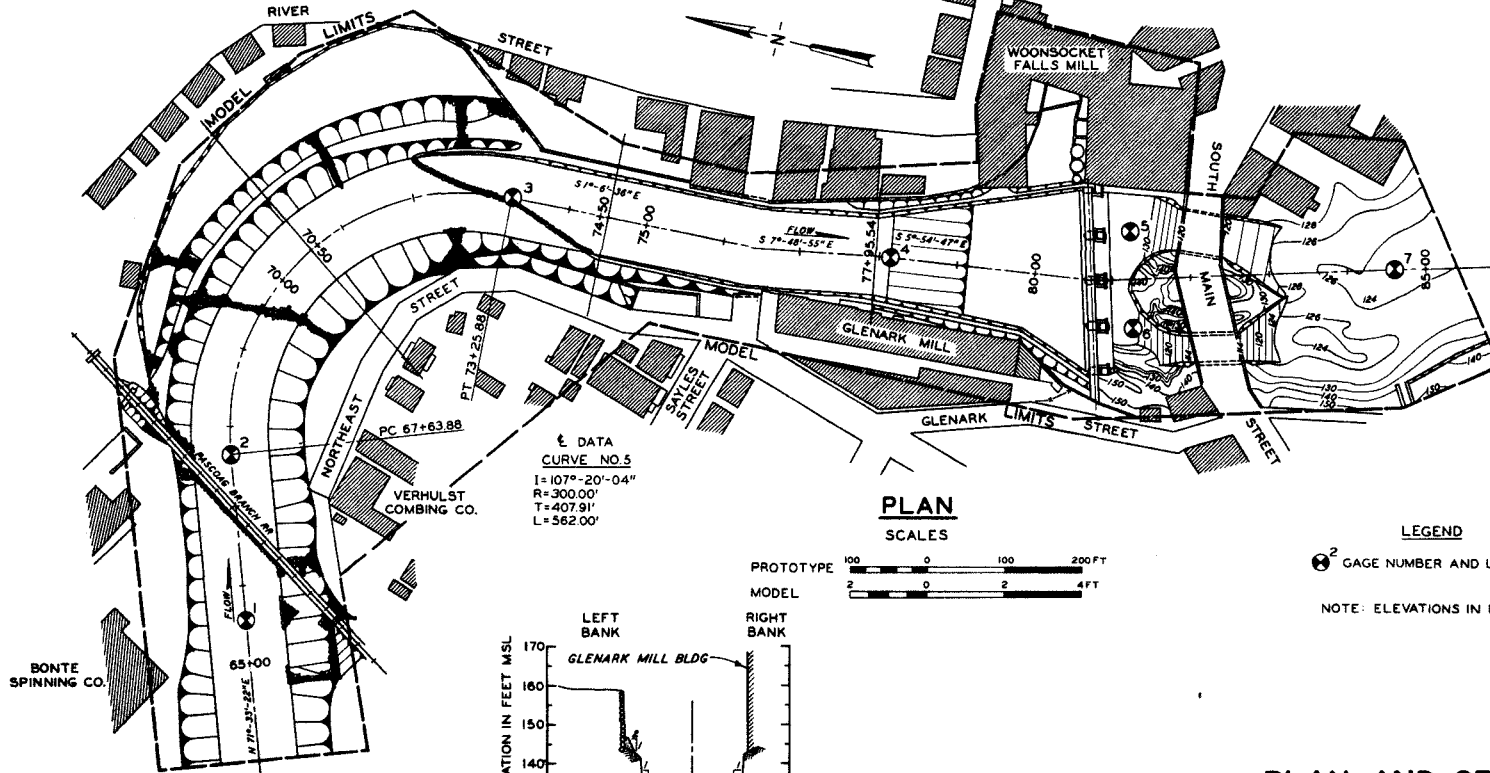

DATA
 CURVE NO. 5
 I = 107°-20'-04"
 R = 300.00'
 T = 407.91'
 L = 562.00'

PLAN
 SCALES

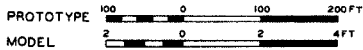

LEGEND

2 GAGE NUMBER AND LOCATION

NOTE: ELEVATIONS IN FT MSL

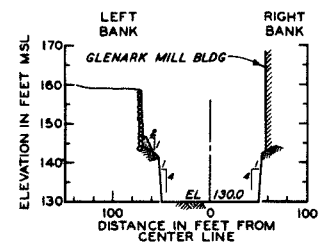

STA 77+95.54

PLAN AND SECTIONS
ORIGINAL CHANNEL
IMPROVEMENT PLAN

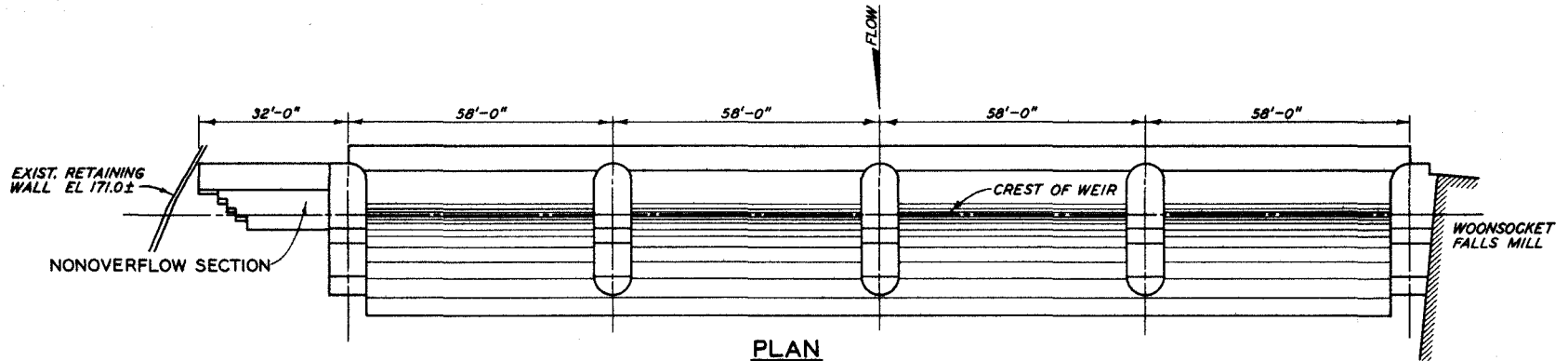

PLAN

SCALE IN FEET

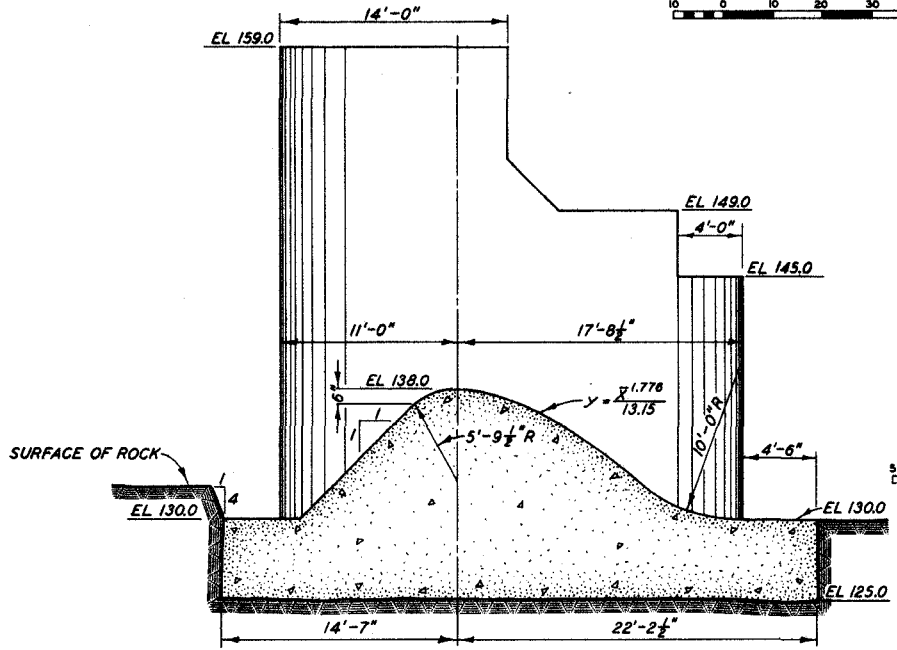
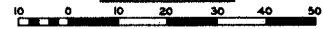

TYPICAL CREST SECTION

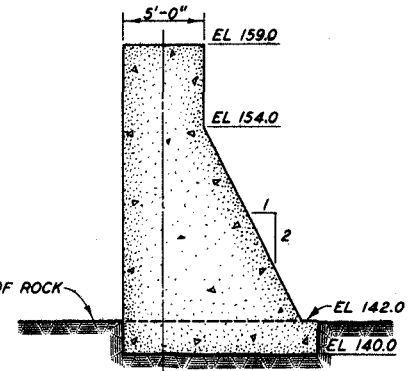

NONOVERFLOW SECTION

SCALE IN FEET

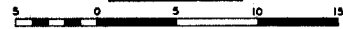

PLAN AND SECTIONS
WOONSOCKET FALLS DAM

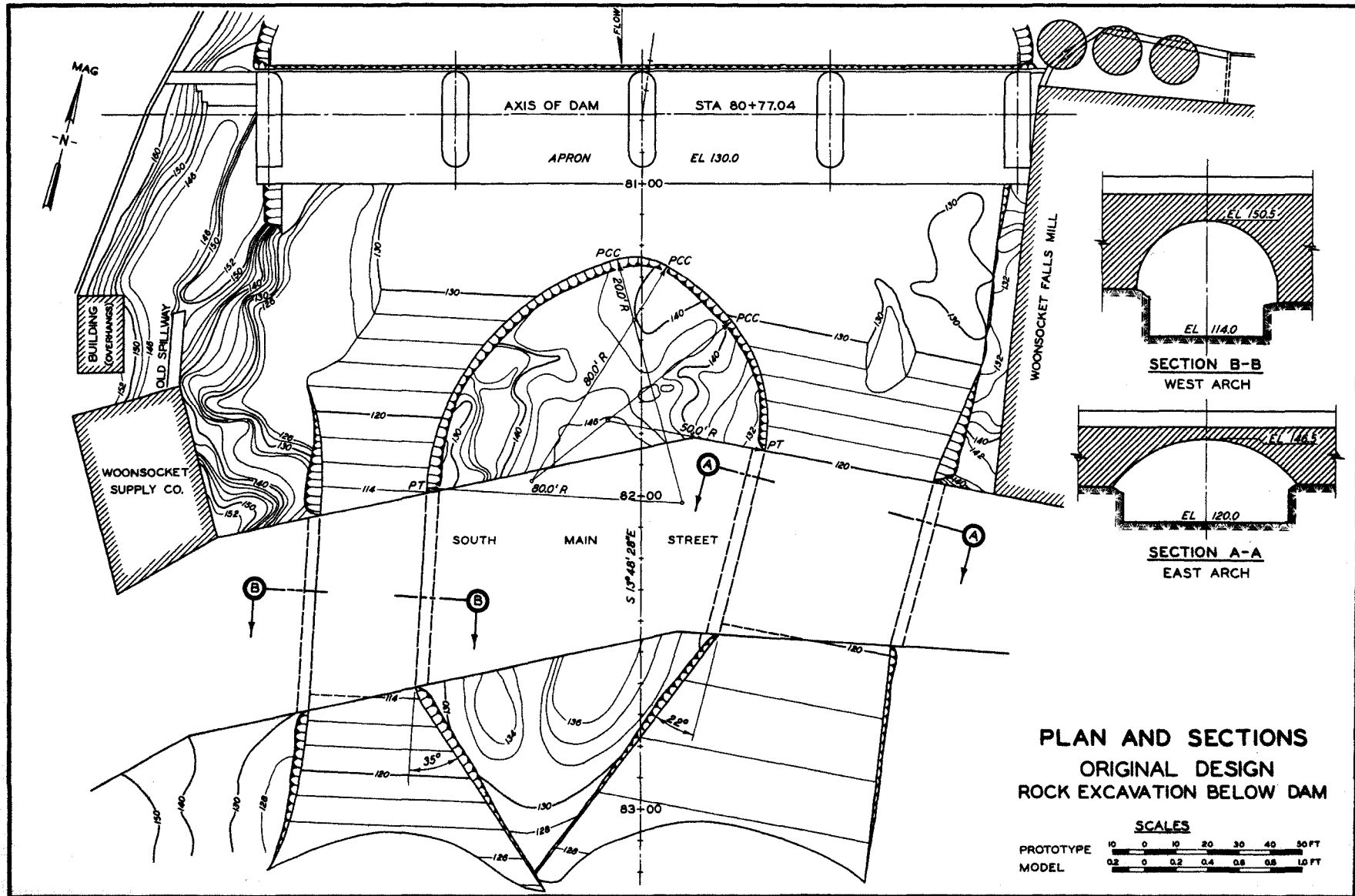

AXIS OF DAM STA 80+77.04

APRON EL 130.0

WOONSOCKET FALLS MILL

BUILDING
COVERWAYS
OLD SPILLWAY

WOONSOCKET
SUPPLY CO.

SOUTH MAIN STREET

SECTION B-B
WEST ARCH

SECTION A-A
EAST ARCH

PLAN AND SECTIONS
 ORIGINAL DESIGN
 ROCK EXCAVATION BELOW DAM

SCALES

PROTOTYPE	0	10	20	30	40	50 FT
MODEL	0	0.2	0.4	0.6	0.8	1.0 FT

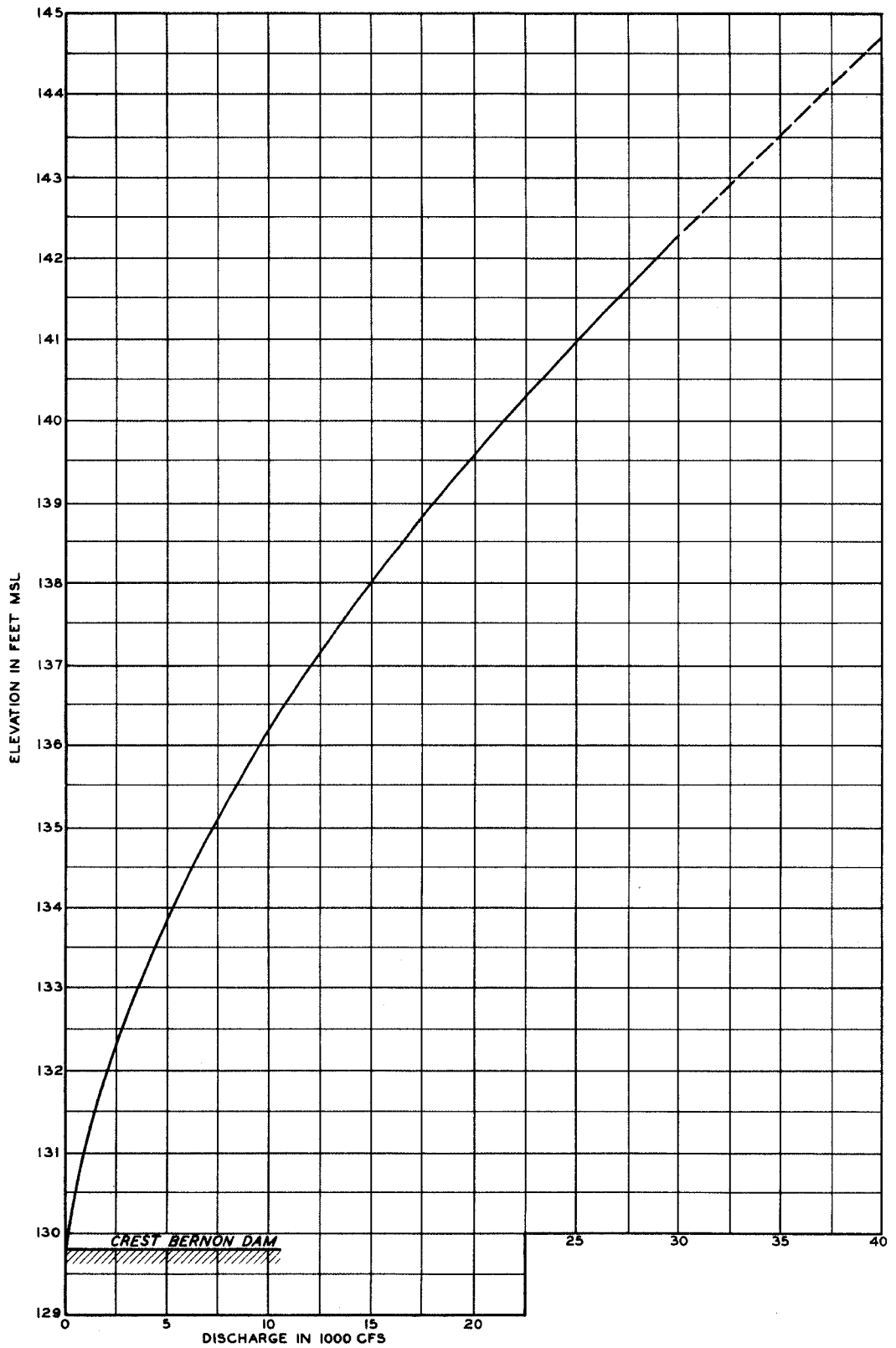

DISCHARGE RATING CURVE

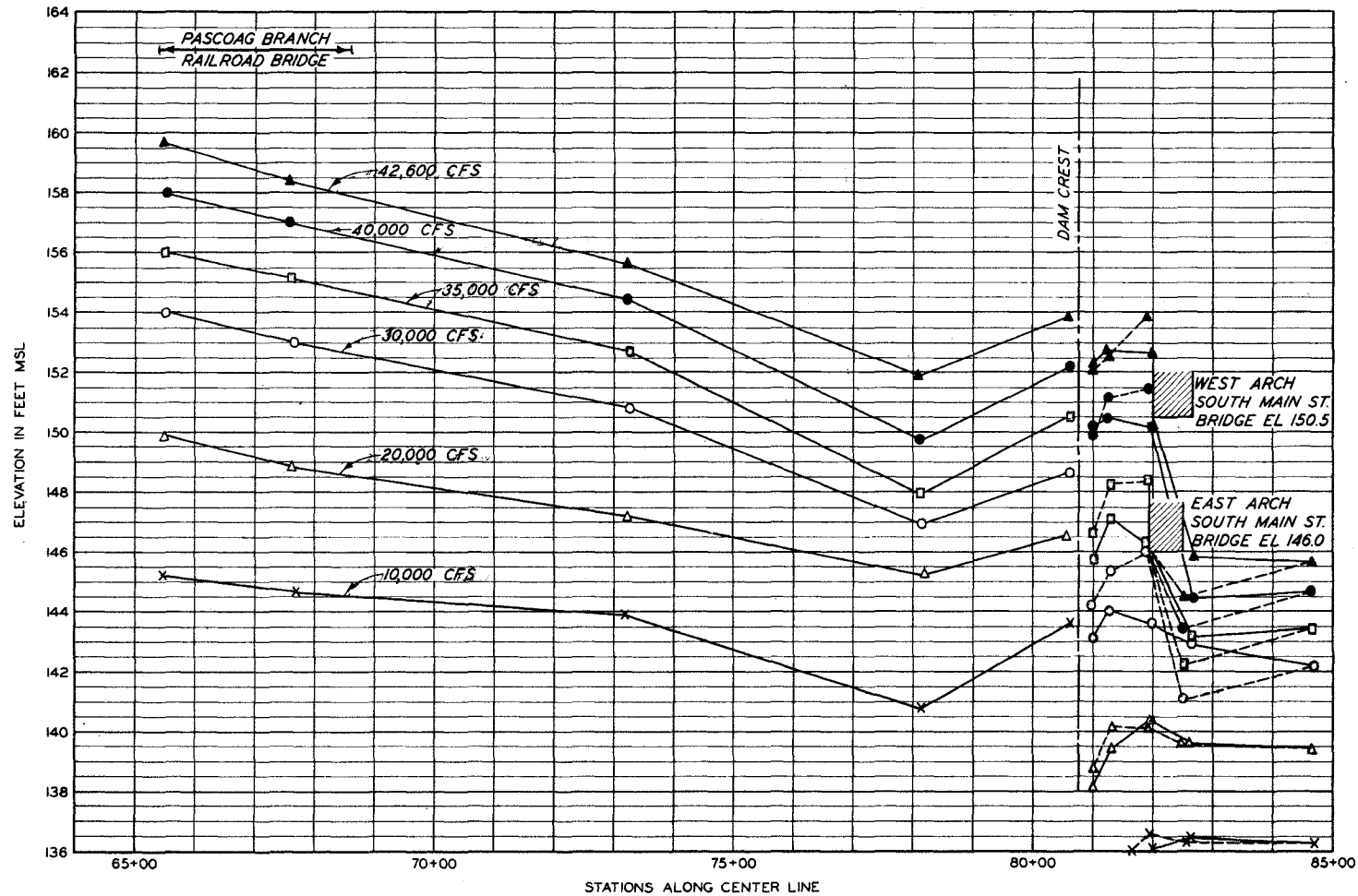

LEGEND
 - - - EAST CHANNEL BELOW DAM
 ——— WEST CHANNEL BELOW DAM

**PROFILES ALONG
 CENTER LINE OF CHANNEL
 ORIGINAL PLAN**

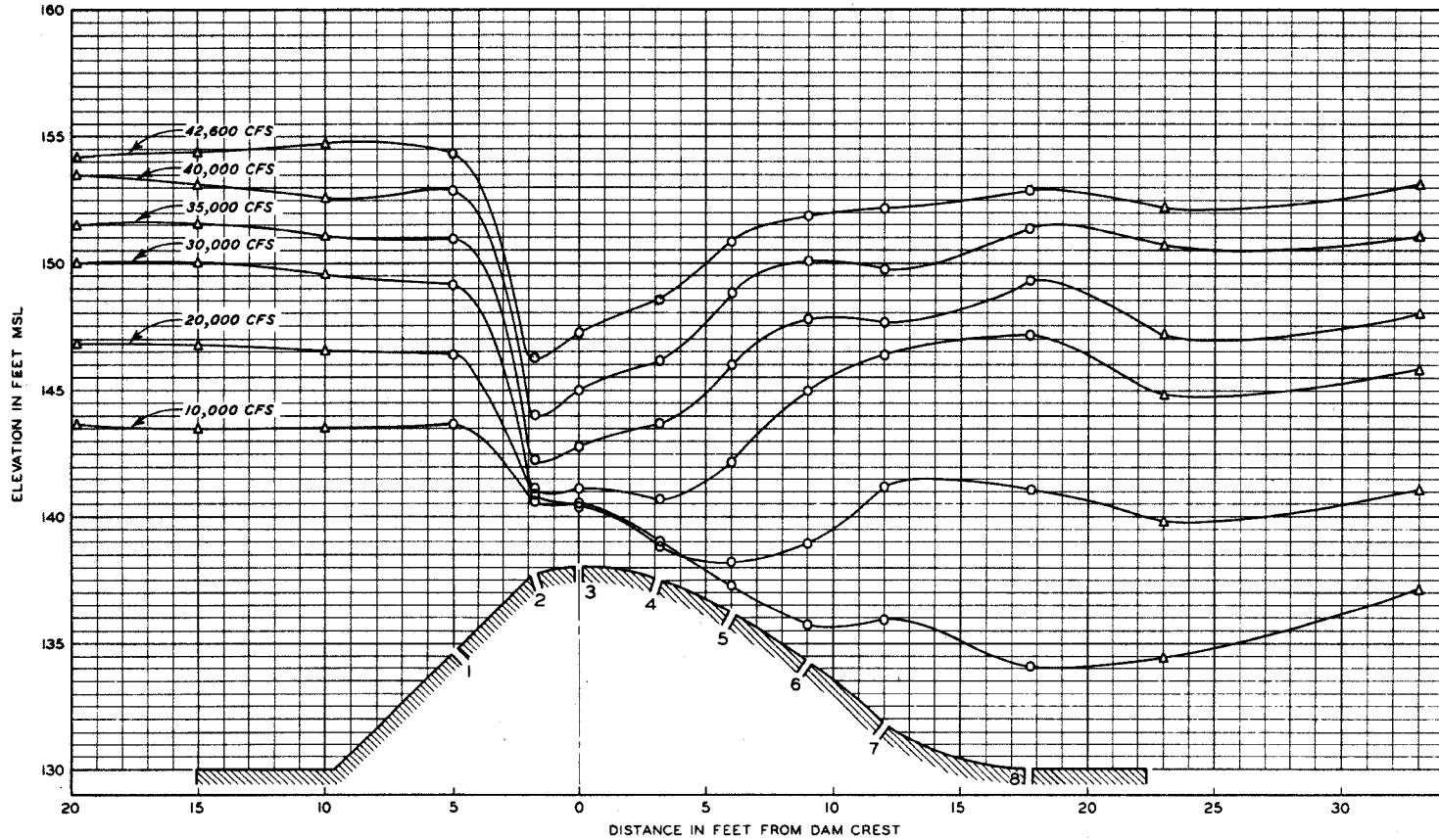

LEGEND

- △ WATER - SURFACE ELEVATIONS
- PIEZOMETER MEASUREMENTS

**PRESSURE GRADIENTS OVER DAM
ORIGINAL PLAN**

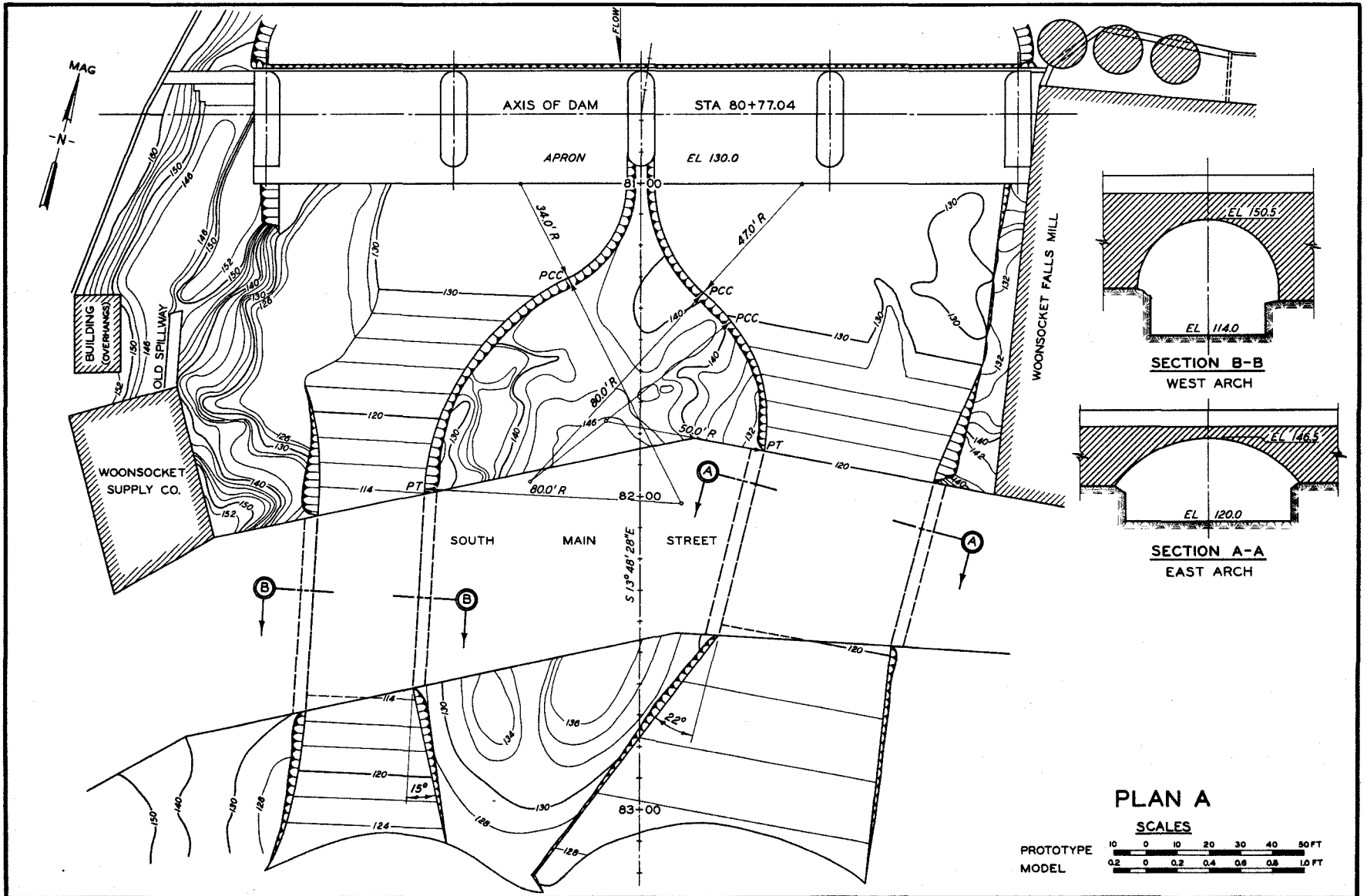

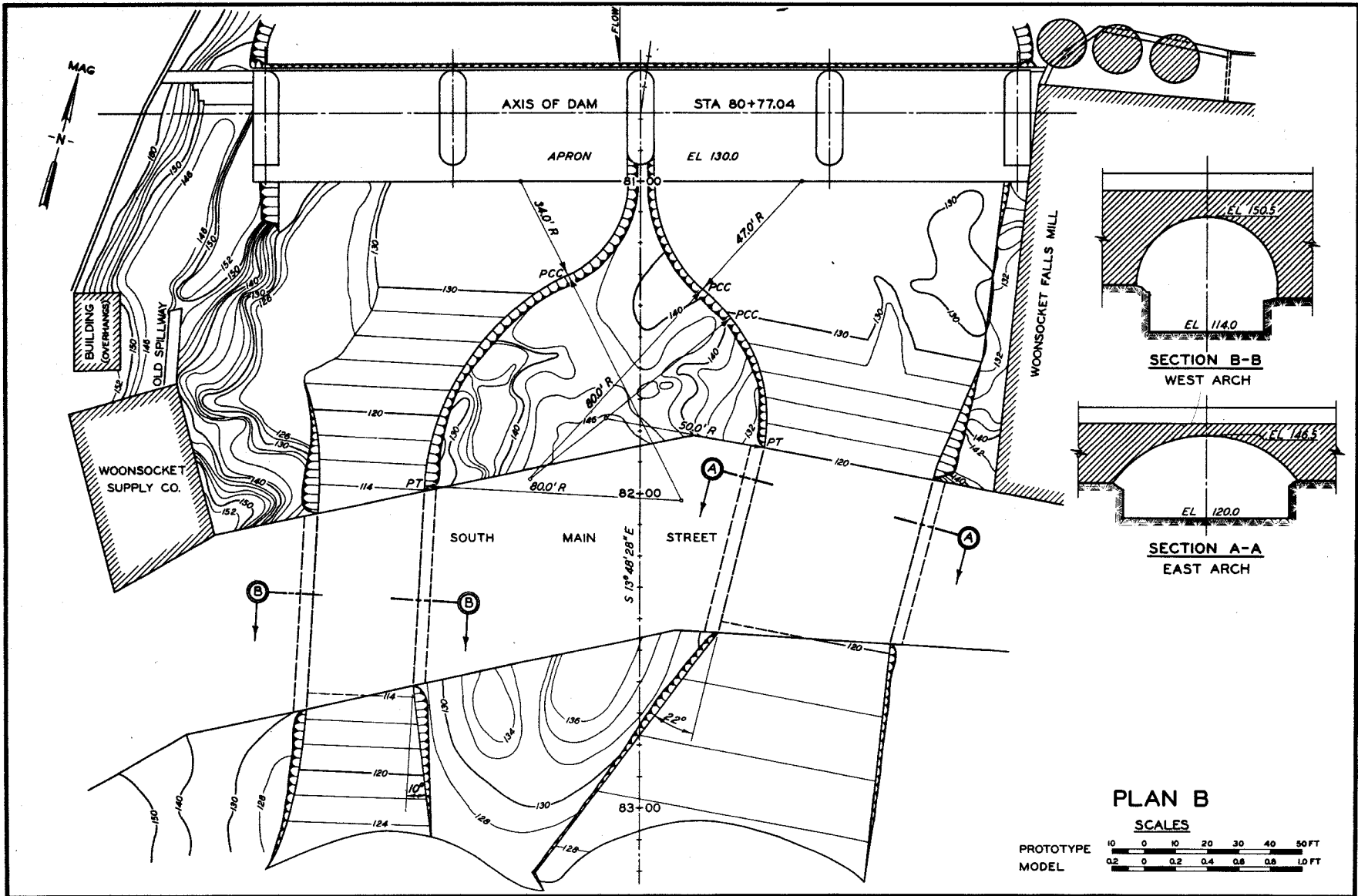

PLAN B

SCALES

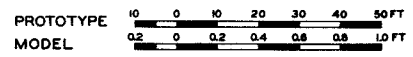

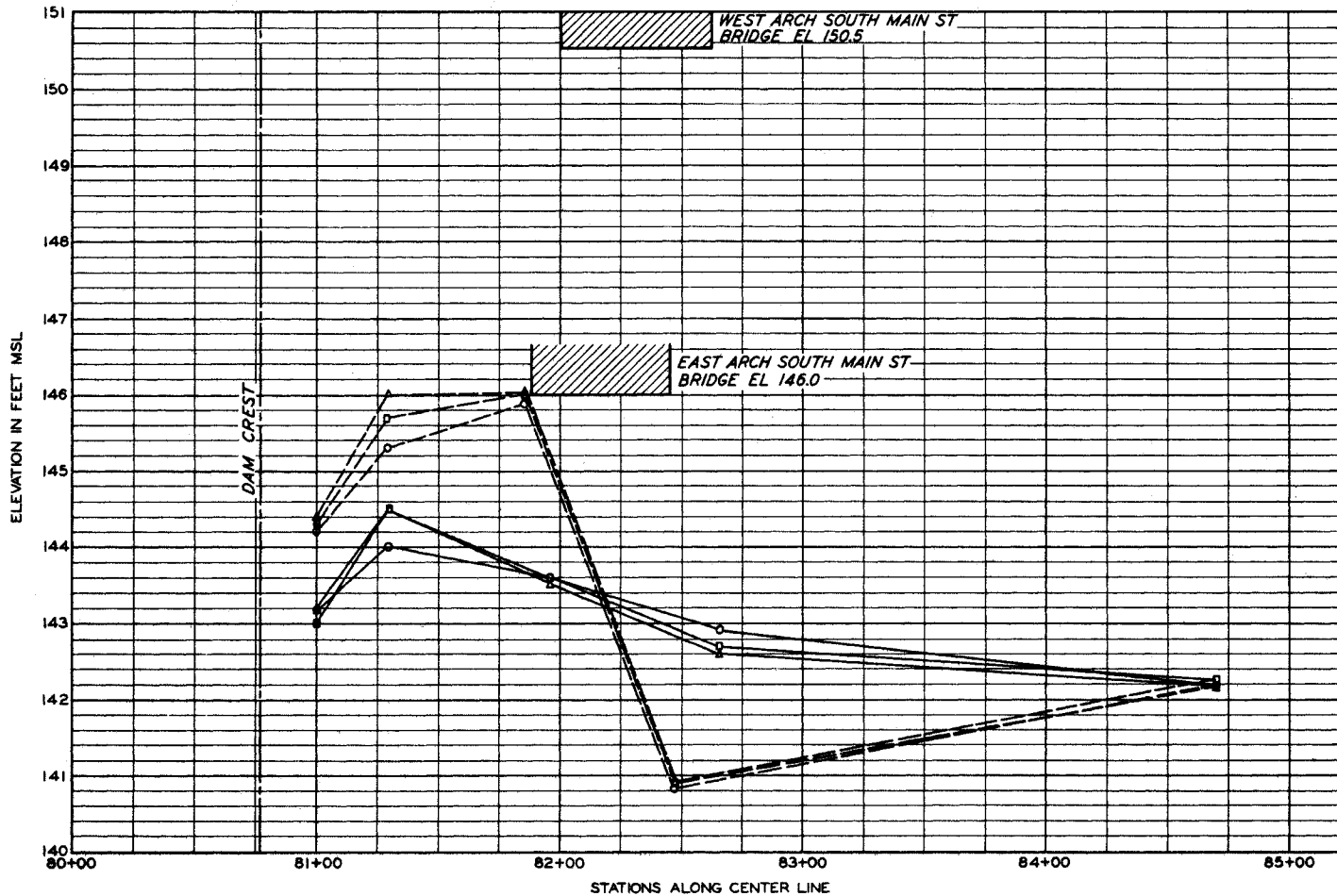

- LEGEND**
- EAST CHANNEL
 - WEST CHANNEL
 - ORIGINAL DESIGN
 - △ PLAN A
 - PLAN B

**PROFILES ALONG
EAST AND WEST CHANNELS
DISCHARGE 30,000 CFS**