

TC158
USSR
TM-2-387

CORPS OF ENGINEERS, U. S. ARMY

**TAINTER GATE TESTS
NORFORK DAM
NORTH FORK RIVER, ARKANSAS**

MODEL AND PROTOTYPE INVESTIGATIONS

CWI ITEM NO. 002



TECHNICAL MEMORANDUM NO. 2-387

CONDUCTED FOR

OFFICE OF THE CHIEF OF ENGINEERS

BY

LITTLE ROCK DISTRICT, CORPS OF ENGINEERS

AND

WATERWAYS EXPERIMENT STATION

VICKSBURG, MISSISSIPPI

ARMY-MRC VICKSBURG, MISS.

JUNE 1954

Report Documentation Page

Form Approved
OMB No. 0704-0188

Public reporting burden for the collection of information is estimated to average 1 hour per response, including the time for reviewing instructions, searching existing data sources, gathering and maintaining the data needed, and completing and reviewing the collection of information. Send comments regarding this burden estimate or any other aspect of this collection of information, including suggestions for reducing this burden, to Washington Headquarters Services, Directorate for Information Operations and Reports, 1215 Jefferson Davis Highway, Suite 1204, Arlington VA 22202-4302. Respondents should be aware that notwithstanding any other provision of law, no person shall be subject to a penalty for failing to comply with a collection of information if it does not display a currently valid OMB control number.

1. REPORT DATE JUN 1954	2. REPORT TYPE	3. DATES COVERED 00-00-1954 to 00-00-1954			
4. TITLE AND SUBTITLE Tainter Gate Tests, Norfolk Dam, North Fork River, Arkansas: Model and Prototype Investigations		5a. CONTRACT NUMBER			
		5b. GRANT NUMBER			
		5c. PROGRAM ELEMENT NUMBER			
6. AUTHOR(S)		5d. PROJECT NUMBER			
		5e. TASK NUMBER			
		5f. WORK UNIT NUMBER			
7. PERFORMING ORGANIZATION NAME(S) AND ADDRESS(ES) U.S. Army Corps of Engineers, Waterway Experiment Station, 3903 Halls Ferry Road, Vicksburg, MS, 39180		8. PERFORMING ORGANIZATION REPORT NUMBER			
9. SPONSORING/MONITORING AGENCY NAME(S) AND ADDRESS(ES)		10. SPONSOR/MONITOR'S ACRONYM(S)			
		11. SPONSOR/MONITOR'S REPORT NUMBER(S)			
12. DISTRIBUTION/AVAILABILITY STATEMENT Approved for public release; distribution unlimited					
13. SUPPLEMENTARY NOTES					
14. ABSTRACT					
15. SUBJECT TERMS					
16. SECURITY CLASSIFICATION OF:			17. LIMITATION OF ABSTRACT	18. NUMBER OF PAGES	19a. NAME OF RESPONSIBLE PERSON
a REPORT unclassified	b ABSTRACT unclassified	c THIS PAGE unclassified	Same as Report (SAR)	96	



FRONTISPIECE. Norfork Dam, North Fork of the White River, Arkansas

PREFACE

The Office, Chief of Engineers, in a continuation of its effort to develop a satisfactory means of controlling the passage of flow through conduits under high heads, proposed a series of model and prototype tests of a tainter-type gate. These tests were conducted under the Civil Works Investigation program on structures, CW 002. The series of model tests was proposed to insure a satisfactory design of the prototype test section to be constructed at Norfork Dam. The model tests were authorized 18 February 1948 by the Office, Chief of Engineers, and were conducted at the Waterways Experiment Station during the period September 1948-March 1949. The prototype tests were undertaken about May 1949 and were continued at periodic intervals through 1951. All prototype tests were supervised by the Little Rock District under the general direction of the Office, Chief of Engineers. The Waterways Experiment Station provided all measuring equipment and personnel for its operation. This report represents the combined efforts of the Waterways Experiment Station, the Little Rock District, and the Office, Chief of Engineers.

CONTENTS

	<u>Page</u>
PREFACE	i
SUMMARY	v
PART I: INTRODUCTION	1
PART II: MODEL INVESTIGATIONS	4
The Model	4
Test Results	4
PART III: PROTOTYPE INVESTIGATIONS	8
Test Section and Tainter-type Gates	8
Gate Seals	10
Instrumentation	11
Test Procedure	15
Test Results	16
PART IV: DISCUSSION AND CONCLUSIONS	26
TABLES 1-28	
PLATES 1-34	

SUMMARY

Results of full-scale tests of a tainter-type control gate under high-head conditions conducted at Norfork Dam, Arkansas, indicated that the hydraulic performance of either the fixed trunnion- or eccentric trunnion-type gate was satisfactory. Pressures on the gate and in the immediate vicinity thereof were positive. Fluctuations of pressure were small and were maximum at full gate opening. Vibration and downpull measurements were difficult to obtain, as seal friction appeared sufficient to influence both to a considerable degree. Visual observation of both type gates revealed no objectionable vibration characteristics. Analysis of data, model and prototype, also indicated that hydraulic downpull forces were small.

Difficulty was experienced with the initial type of seals investigated with the fixed trunnion-type gate; these seals were actuated by water pressure from the reservoir. This difficulty was alleviated by use of a pneumatically operated gate seal. The use of the eccentric trunnion-type gate provided positive sealing action and no trouble was encountered.

TAINTER GATE TESTS
NORFORK DAM
NORTH FORK RIVER, ARKANSAS

Model and Prototype Investigations

PART I: INTRODUCTION

1. The need for control of conduit discharges by partially, rather than fully, open control gates has resulted from fine reservoir-regulation requirements. Experience has shown that many existing gates have undesirable characteristics, such as excessive downpull forces, chatter, and vibration, when operated at partial opening under high-head conditions.

2. A comprehensive gate testing program was initiated by the Office, Chief of Engineers, as part of its Civil Works Investigation program on structures, CW 002, in an attempt to develop a control gate that would operate satisfactorily under high heads. The program included both model and prototype tests of slide-* and tainter-type gates. Advantages of the tainter-type gate are: (a) much smaller force required to operate than for slide gates; (b) the gate slots can be omitted; (c) the sharp edge of the gate lip minimizes downpull forces; and (d) the air vent can be eliminated and air supplied by the gate shaft. A disadvantage of large tainter-type gates, however, is the relatively large gate shaft required unless assembly of the gate and maintenance are done at the base of the shaft.

3. Tests on a 1:6-scale model of the proposed field installation were undertaken to insure a satisfactory shape of gate chamber and to establish pressure limits for the design of prototype measuring equipment. The model data obtained consist of measurements of pressures acting on the gate and at various locations in the gate chamber and conduit proper, and measurements of hydraulic forces acting on the lifting stem.

* Waterways Experiment Station Technical Memorandum No. 2-280, "Slide Gate Tests, Norfork Dam, North Fork River, Arkansas."

4. The purpose of the prototype tests was to verify and extend the experimental data obtained on the model. In addition to observations of the general hydraulic performance of the gate at various openings, measurements were made of: (a) pressures on the gate and in the surrounding gate chamber; (b) vibration of the gate in three planes (vertical, longitudinal, and transverse); (c) downpull forces; and (d) air requirements. Two types of gates were used in the tests: one gate moved radially about a fixed trunnion with inflated seals to seal against the gate, and the other gate moved radially about an eccentric trunnion which permitted the gate to be moved slightly upstream after closing so as to seal against fixed seals. Tests also were made to develop a satisfactory gate seal of simple design which would prevent leakage with the gate in a closed position.

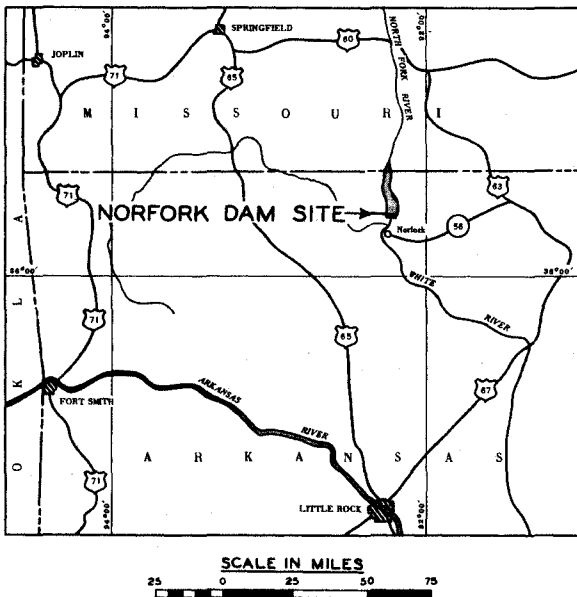

Fig. 1. Vicinity map

abutment, is 568 ft wide and has a crest elevation of 552.* Twelve tainter gates, 40 ft wide and 28 ft high, are located on the spillway crest to control overflow. The stilling basin, 568 ft wide and 181.5 ft long, has a floor elevation of 362. Two rows of baffle piers 8 ft high and a stepped end sill 6 ft high are located on the basin floor to assist

5. In view of the relatively high heads available at Norfolk Dam, this dam, located in northern Arkansas on the North Fork of the White River (fig. 1), was selected as the site for the prototype tainter gate tests. (The prototype tests of the slide gates, referred to in paragraph 2, also were conducted at this site.) The dam (frontispiece and plate 1) is a concrete gravity structure 2624 ft long and 233 ft high. The spillway, located near the left

* All elevations are in feet above mean sea level.

in the dissipation of energy contained in spillway and conduit flows.

6. Eleven flood-control conduits, each 4 ft wide by 6 ft high, are provided through the base of the spillway section. The combined capacity of the conduits with the reservoir at spillway crest is 21,000 cfs. Each conduit has a bellmouthed entrance with invert at elevation 394.99. The conduits are inclined downward on a constant slope of about 8-1/2 degrees to an intersection with the stilling basin. Flow through each conduit is controlled by two hydraulically operated slide gates in tandem, the downstream gate being used for normal operation and the upstream gate being reserved for emergency operation. The gates are operated from control rooms located just above each conduit, which are reached through an operating gallery with floor elevation of 404.4.

PART II: MODEL INVESTIGATIONS

The Model

7. The gate chamber and a short section of the conduit upstream and downstream therefrom were modeled in plastic to a scale of 1:6. The tainter gate was constructed of brass with all exposed structural members reproduced. The trunnion was seated in ball-bearing rings to reduce friction effect to a minimum. The test section was installed in a pipeline equipped with venturi meters for measurement of discharge (plate 2). No attempt was made to simulate the downstream end of the test section. Instead of discharging freely, the test section discharged into a pipe located downstream from whence flow returned to the sump. The effect of tailwater in the gate chamber was investigated by introducing back pressure by means of a valve in the line. Data procured consisted of visual observations of flow conditions, average pressure measurements throughout the gate chamber and immediate vicinity and on the face of the gate proper, measurements of forces tending to rotate the gate about the trunnion, and determinations of head-discharge relations.

8. Measurements of average pressure were made by piezometers located at critical areas in the test section (plate 3). Forces tending to rotate the gate about the trunnion were determined by a dynamometer arrangement connected to the lifting stem of the gate (plate 4). The dynamometer consisted of a 1/16-in.-thick piece of spring steel on which SR-4 strain gages were located. As the steel bar was flexed under the action of the forces on the gate, the resistance to current being passed through the strain gages varied, thus indicating the actual force being applied. Current change, or force variation, was recorded by means of a recording oscillograph.

Test Results

9. General hydraulic performance of the tainter-type control gate appeared satisfactory for full and part gate opening. At part gate

opening and partial conduit flow (figs. 2 and 3), the flow under and through the gate chamber was smooth, and no tendency toward gate vibration was noted. As the conduit and gate chamber filled, an eddy developed downstream from the gate and tended to close it by impact on the structural members of the gate. This action is typical of all gates of this type when the conduit downstream from the gate flows full. Under this condition vibration tendencies of the Norfolk model gate did not appear large.

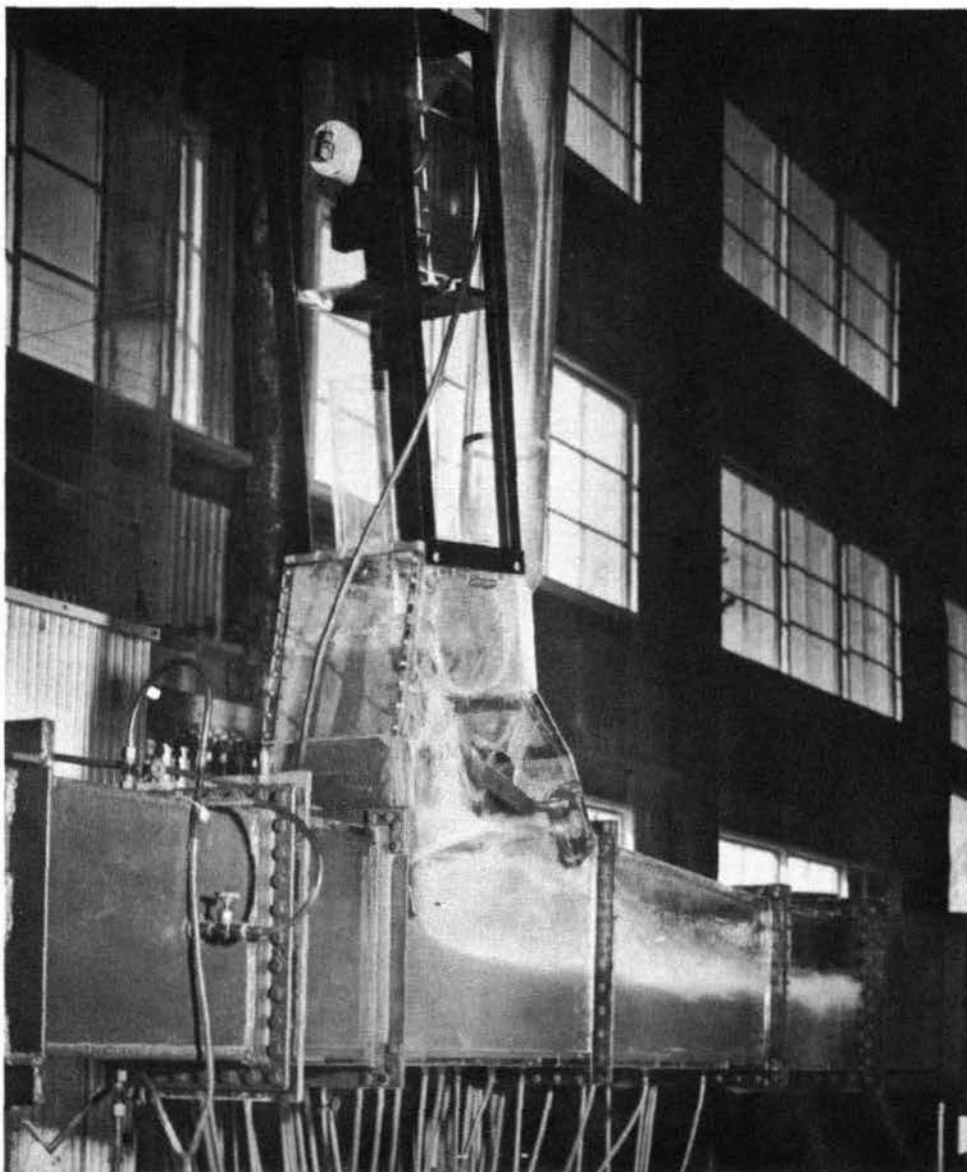

Fig. 2. Flow conditions vicinity of model tainter gate, gate open 4 ft

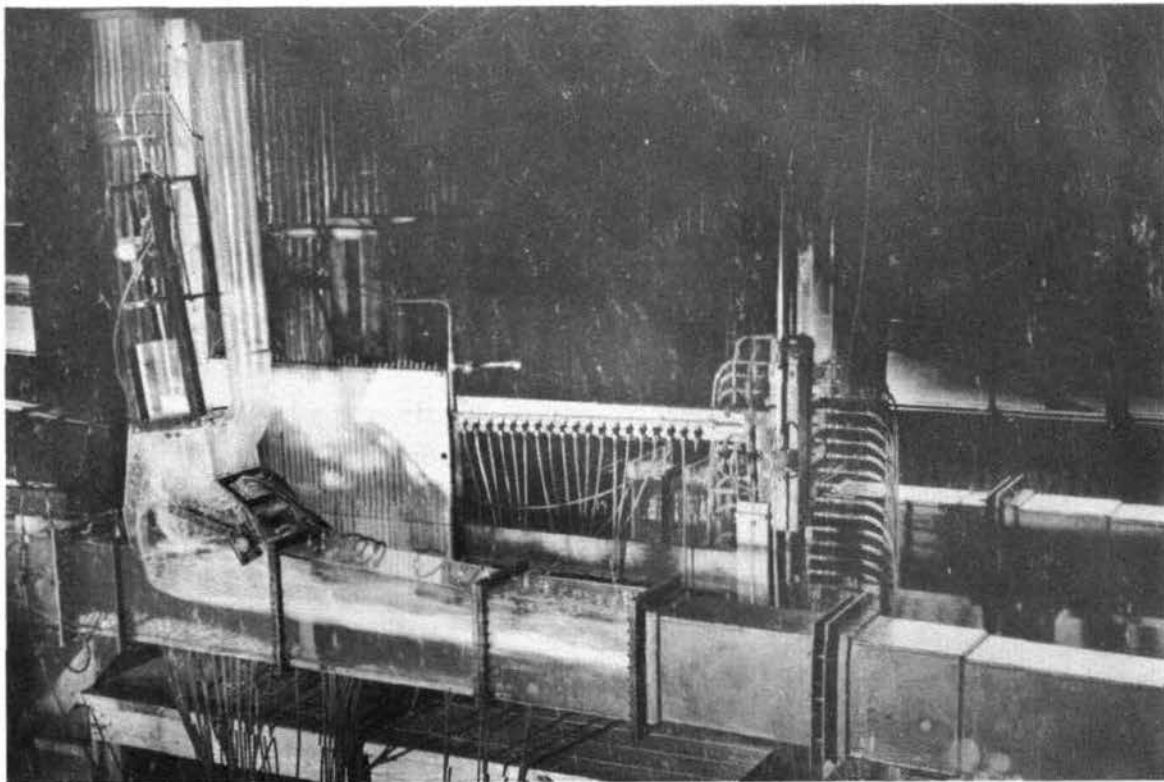

Fig. 3. Flow conditions through model test section, gate open 4 ft

10. Average pressure data recorded for various head and gate openings are presented in tables 1-9. To permit the application of data to other head conditions, a pressure coefficient was also computed. This coefficient for a particular piezometer was equal to the recorded pressure divided by the total head at a control piezometer. The control piezometer was located in the roof of the conduit 18.29 ft upstream from the gate trunnion. No unusual pressure conditions for the various head and gate openings tested were noted. Comparisons of model and prototype pressure data have been made in later paragraphs.

11. Measurements of the hydraulic forces tending to rotate the gate about the trunnion are presented in table 10, which shows maximum, minimum, and computed average forces including and excluding the weight of the gate. From these tests it was concluded that the actual hydraulic downpull was small for gate openings of 5 ft or less, ranging from an average of 300 to 400 lb. For full gate opening the average hydraulic

force recorded was 1879 lb as compared to 6394 lb resulting from the weight of the gate alone. In every instance the average force involved tended to close the gate. Variation in total downpull from maximum to minimum averaged about 1000 lb for most conditions of gate opening. No comparison of hydraulic forces measured in model and prototype was possible because of the large seal friction in the prototype.

12. Head-discharge relations established for free exit conditions (no tailwater) at each gate opening are shown on plate 5. The head indicated is the total head at the control piezometer. Since no prototype head-discharge relations were determined, these data may be used as a basis for computation of flow through the prototype gate.

PART III: PROTOTYPE INVESTIGATIONS

Test Section and Tainter-type Gates

13. For the purpose of the prototype tests, the conduit adjacent to the left training wall was extended into the stilling-basin area. The tainter gates to be tested were located approximately at the downstream face of the dam within the conduit extension. The fixed-trunnion type gate had a radius of 9 ft and was constructed entirely of steel with provision for installation of measuring equipment (figs. 4 and 5 and plates 6 and 7). The trunnion of the gate was located on the downstream side, placing all structural members of the gate in compression.



Fig. 4. Upstream face of gate

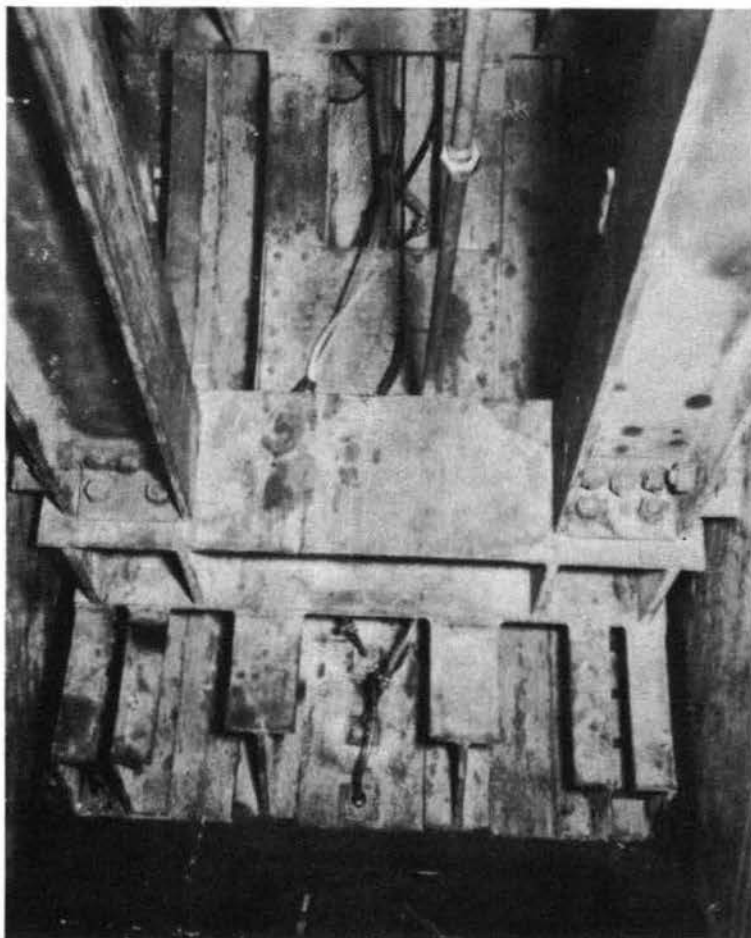

Fig. 5. Downstream face of gate

The lifting mechanism consisted of a screw stem powered by an electric motor through suitable gears. The screw stem was connected by means of a crosshead to a lifting strut composed of an 8-ft length of 4-in. steel pipe. With the gate completely closed the gate seat was at elevation 368.74. Since the reservoir water surface during the tests was at elevation 550.80, the head on the gate was approximately 182.1 ft. The walls and roof of the conduit extension were lined with steel plate for approximately 16 ft upstream and 20 ft downstream from the gate trunnion. At the entrance to the gate chamber the conduit was 3 ft 11 in. wide and 6 ft high. Downstream from the gate trunnion, the conduit had a sloping roof which reduced the height of conduit from 7 ft at the trunnion to 6 ft at a location 15 ft farther downstream. The gate chamber was vented by a 30-in.-diameter pipe. Auxiliary air vents were located in the roof

of the conduit downstream but were not used in this series of tests.

14. The eccentric trunnion-type gate investigated also had a radius of 9 ft and was constructed similarly to the fixed trunnion gate. The lifting mechanism was the same as that used for the fixed trunnion gate. The horizontal movement was accomplished by a similar lifting mechanism operating the eccentric trunnion (plate 8). The screw stem was connected by means of a crosshead to a lifting strut, which in turn was connected to the gate trunnion through an operating arm.

Gate Seals

Fixed trunnion-type gate

15. Two types of seals (hydraulic and pneumatic) were proposed for the fixed trunnion gate. The hydraulic seal was of an expanding type. It was attached to the gate, and was sealed against the fixed metal surfaces of the conduit sides by expansion under internal water pressure provided through pipes connected to reservoir pressure at the upstream face of the gate. Upon release of the water pressure the seal deflated and cleared the sides of the conduit for movement of the gate. The details of this seal are shown as types A and C on plate 7. The type B seal, which was attached to the masonry, was proposed as an alternate hydraulic seal for the top of the gate. After the hydraulic seals were tested, a pneumatic seal was substituted (plate 9). The pneumatic side seals were attached to the gate and expanded by internal pressure for tight contact with the sides of the conduit. The top pneumatic seal was fixed in place and expanded by air pressure to seal against the skin plate of the gate. Air was provided by a compressor located on top of the structure. Upon deflation the seals retracted from contact and permitted movement of the gate.

Eccentric trunnion-type gate

16. The seals for the eccentric trunnion gate were fixed to the sides and top of the conduit with a slight clearance between the seals and the gate in the unsealed position. The eccentric trunnion moved the gate about 1/2 in. upstream, compressing the fixed seals about 1/4 in.

Two types of seals were used in these tests, one was a J seal and the other a rectangular block seal. Tests were first made with fixed seals on the sides and top of the conduit while the bottom of the gate was sealed in a recess provided in the lead bottom seal. Later a rubber seal was also placed across the bottom of the conduit and the tests were repeated. These two seals are shown as types D and E on plate 10.

Instrumentation

Fixed trunnion-type gate

17. Data obtained in the prototype tests included average and instantaneous pressures on the gate and in the gate chamber, gate vibration in three directions, downpull forces, and air flow. Average pressures on the gate and walls of the conduit were measured by means of 44 piezometers. Six of these piezometers were located in the wall and roof of the conduit upstream from the gate, 11 were located in the floor of the conduit immediately under and downstream from the gate, 6 were located on the gate, 8 were located in the wall of the conduit downstream from the gate, and 13 were located in the gate recess and in the roof of the conduit downstream from the gate. The locations of the piezometers are shown on plate 11. An inspection of each one was made prior to the start of the tests to insure freedom from burrs or other obstructions that might result in erroneous readings. All piezometric pressures were recorded by means of a single U-tube and a Bourdon-type dial gage. These gages were attached to the piezometers through a system of valves which facilitated the reading of the pressure at any one of the 44 locations. Fig. 6 shows the valve bank and gages used to record average pressures.

18. Instantaneous pressures were measured by means of eight electrical pressure cells located as shown on plate 11. Three of the cells were located in the floor of the conduit, one in the gate chamber, two in the roof of the conduit, and two on the gate. Each cell was about 1 in. in diameter, surrounded by a mounting plate approximately 2 in. in diameter. The face of each cell consisted of a thin diaphragm with two SR-4 strain gages bonded to its inner side. The cells were designed for

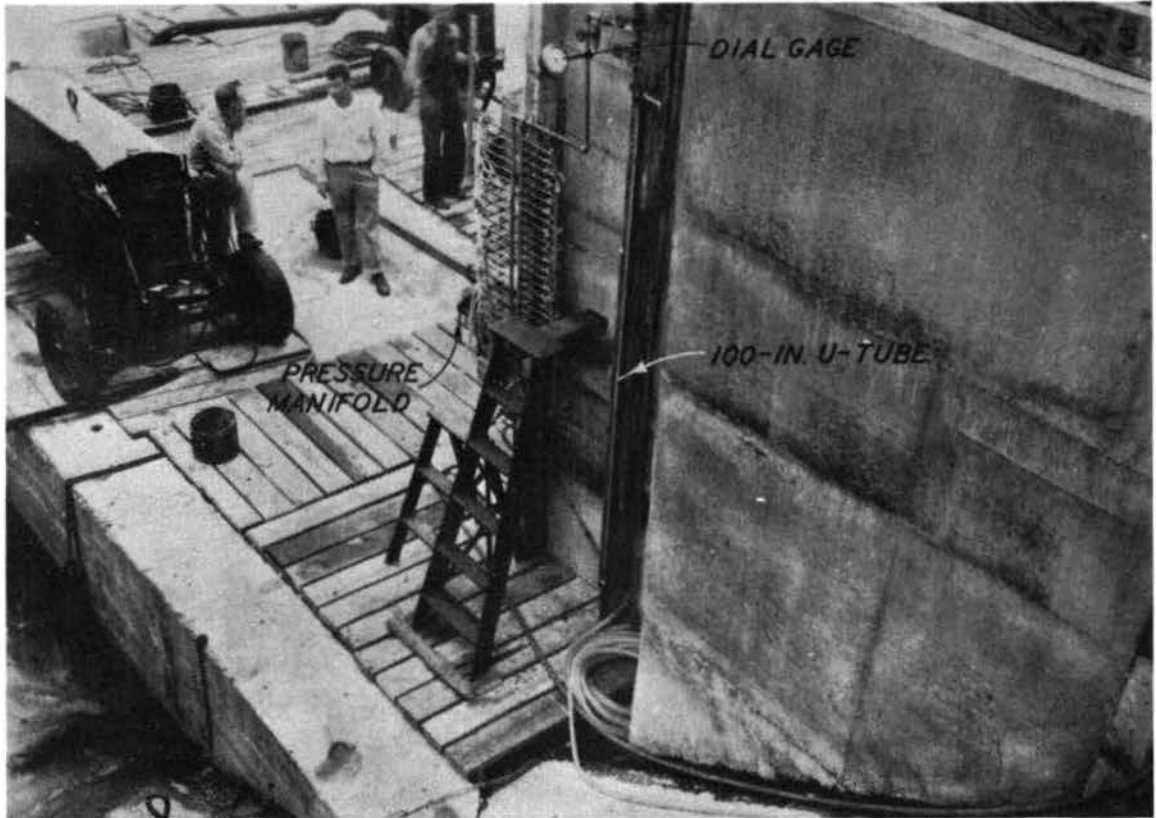

Fig. 6. Measuring equipment to obtain pressures on gate and walls of conduit by piezometric method

use with pressures ranging from -15 to 75 psi and were calibrated prior to installation in the test section. Recording and amplifying equipment used are shown in fig. 7.

19. Vibration of the tainter gate was measured with Brush vibration pickups, a commercial product of the Brush Development Company. This instrument is of the inertia type that utilizes piezoelectric crystal elements as the generating members. Movement of the crystal element in a direction normal to its face generates a small voltage that is approximately proportional to the acceleration the crystal receives when applied to a vibrating body. A permanent record was obtained by use of a recording oscillograph. Three vibration pickups (accelerometers) were mounted on the downstream side of the skin plate (plate 11) to record oscillation perpendicular to the skin plate, transverse to the direction of flow, and about the trunnion. These directions are referred to in

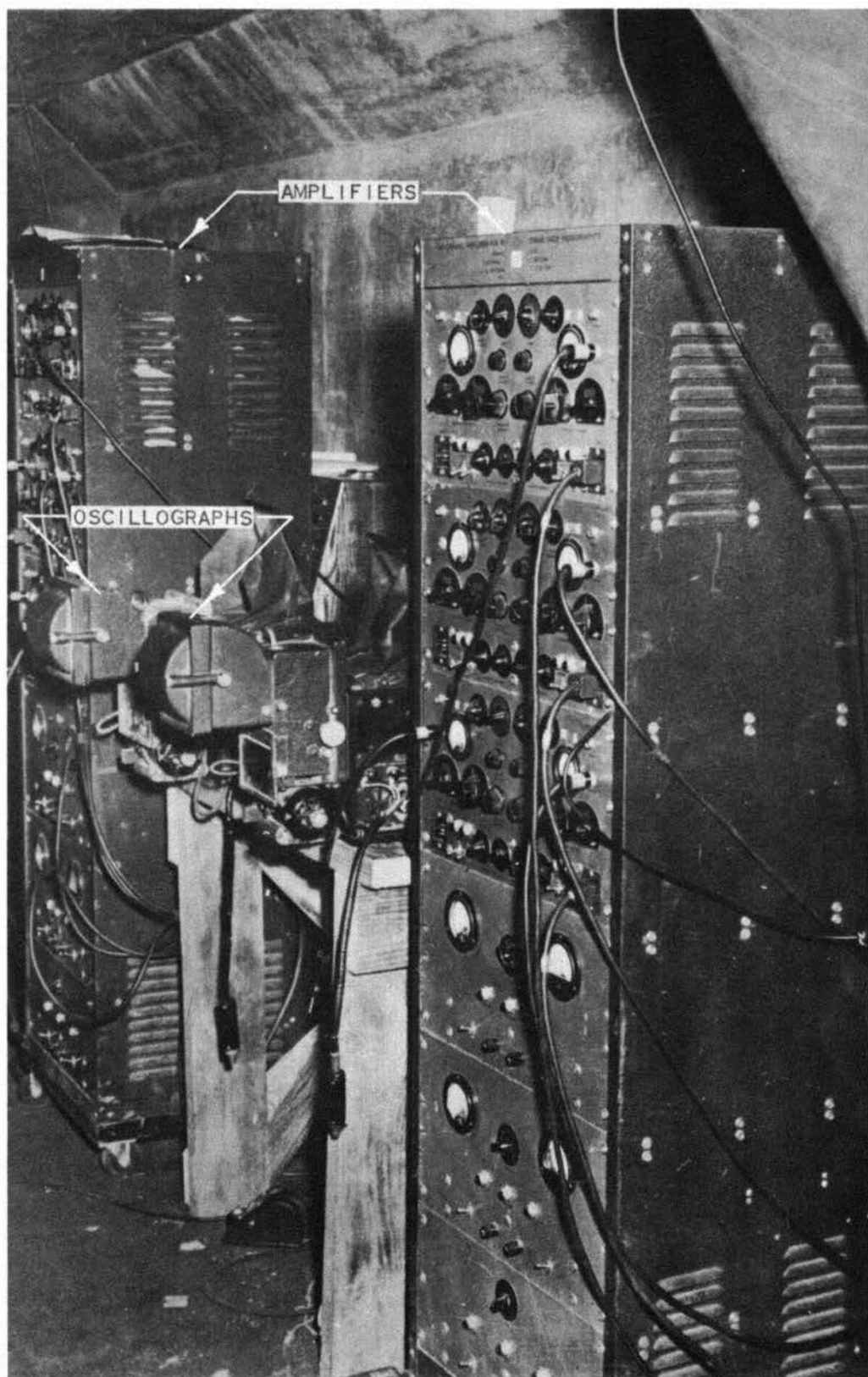

Fig. 7. Apparatus for measuring and recording resistance change in SR-4 strain gages (pressure cells). Shown are two 6-channel amplifiers and two Westinghouse type P.A. recording oscillographs

this report as longitudinal, transverse, and vertical, respectively. All vibrations recorded are relative, being referenced to the maximum displacement of the gate. Actual amplitude of movement could not be determined.

20. Downpull measurements were made with SR-4 strain gages mounted on the lifting strut of the gate. Any tension or compression of the lifting strut resulted in a corresponding deformation of the strain gage and a change in the electrical resistance of the gage. This change in electrical resistance was related to stress in the lifting strut and downpull.

21. The air flow at each gate opening was determined by circular orifice plates located on top of the 30-in.-diameter air vent (plate 6). A pressure tap was located 1 in. below the orifice plate, and the dif-

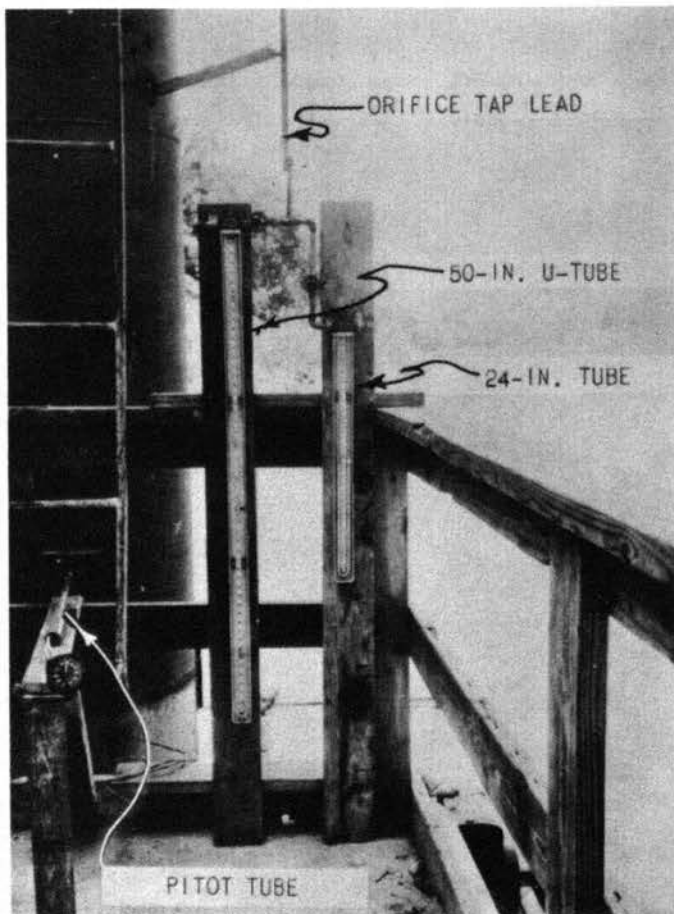

Fig. 8. Measuring equipment to obtain air flow through air vent for various size orifices

ferential between atmospheric and tap pressures was measured by a U-tube manometer (fig. 8). The orifice plates were of the square-edge type with diameters (20, 16, 12, and 8 in.); these resulted in orifice areas equal to 44.4, 28.4, 16.0, and 7.1 per cent of the area of the vent, respectively. The method recommended by the American Society of Mechanical Engineers in its publication entitled "Flow Measurement," dated 1940, was used in transforming manometer readings to rate of air flow. A constant coefficient of discharge of 0.6 was assumed. The orifice plates served a dual purpose by providing a

means of measurement and by restricting the flow of air down the vent, thus permitting study of the effect of the amount of air flow upon the other flow characteristics. Attempts made to measure air supply by means of pitot-tube traverses of the pipe were unsuccessful.

22. The reservoir elevation was recorded by a float-type gage, while tailwater elevations were recorded with a staff gage. The tailwater gage was located on the right wall of the stilling basin, out of the zone of disturbance created by conduit flow. No attempt was made to measure the discharge.

Eccentric trunnion-type gate

23. Instrumentation for the eccentric trunnion-type gate was confined to the use of three Statham-type accelerometers for measurement of vibration, and strain gages on the lifting stem for recording hoist requirements. No pressures, average or instantaneous, nor air flow measurements were made.

24. Vibration measurements were made with accelerometers located within a welded steel box which was an integral part of the gate. The signals from the accelerometers were amplified by Brush BL-320 Universal analyzers and recorded on a Brush six-channel recorder. Accelerometer readings on the recorders were in terms of the acceleration of gravity rather than in terms of relative displacement as was the case with the fixed trunnion-type gate.

25. Downpull or uplift forces were recorded with SR-4 strain gages in the same manner as outlined in paragraph 20.

Test Procedure

26. The general test procedure consisted of securing a set of measurements with full gate opening and then obtaining similar measurements with progressively smaller openings. In all, 13 gate openings were investigated varying from full opening at 6.1 ft to the smallest opening at 0.25 ft. All gate openings were measured perpendicular to the floor of the conduit. After the gate was completely closed, it was raised to the same openings and additional data were procured as a check on those

obtained during the closing operation. To insure that the electrical apparatus was in working order for all tests, measurements of instantaneous pressure, vibrations, and strain on the lifting strut were made prior to measurement of average pressures. Similar test runs were made with the orifice plates, previously described, installed on top of the 30-in.-diameter air vent. After all tests were completed with the electrical apparatus, average pressures were measured with the piezometers for similar conditions of gate opening and vent restriction.

27. Tailwater conditions during the tests were governed for the most part by conduit and power discharges (plate 12). It was possible, however, to secure one series of pressure measurements when power was not being generated, resulting in a 2.0- to 2.5-ft lower tailwater.

Test Results

Fixed trunnion-type gate

28. General hydraulic performance. Observation of the general hydraulic performance of the fixed trunnion-type gate revealed satisfactory results in almost every detail. The manhole opening into the roof of the gate chamber near the trunnion permitted direct observation of flow until the gate was opened about 5.5 ft. At no time was there any evidence of vibration of the gate or gate members. At full gate opening the manhole opening had to be closed, and observations of flow within the gate chamber were not possible. Neither were observations through the window in the side of the gate chamber, which had been provided for the purpose, of any value. However, no vibration tendencies transmitted through the gate stem or surrounding structure were apparent. Figs. 9 and 10 show flow conditions in the exit area downstream from the test section.

29. Average pressure measurements. Measurements of average pressures for various gate openings and air vent conditions are presented in tables 13-18. The zero elevation of each piezometer is shown in tables 11 and 12. The zeros of piezometers 39-44 were determined by the gate opening. At gate openings of less than 6.0 ft, air was drawn into the gate recess from the air vent, thus preventing any pressure readings on

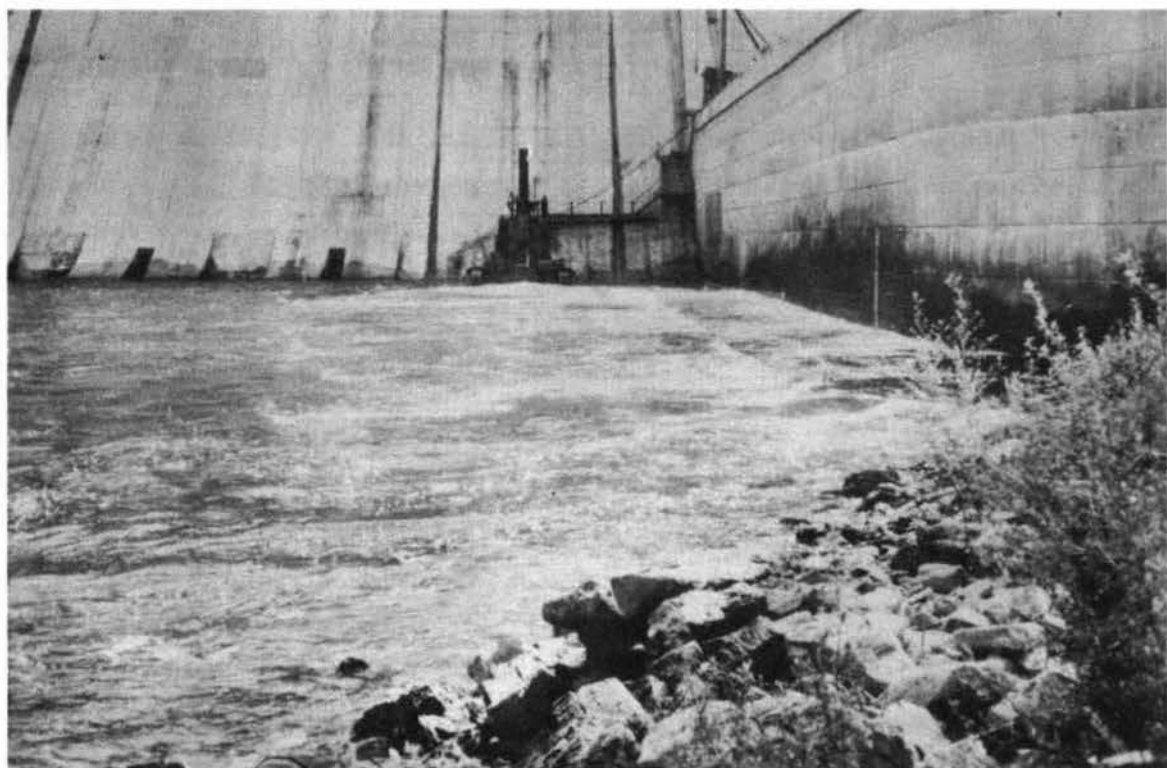

Fig. 9. Flow conditions in stilling basin downstream from test section, gate open 0.5 ft

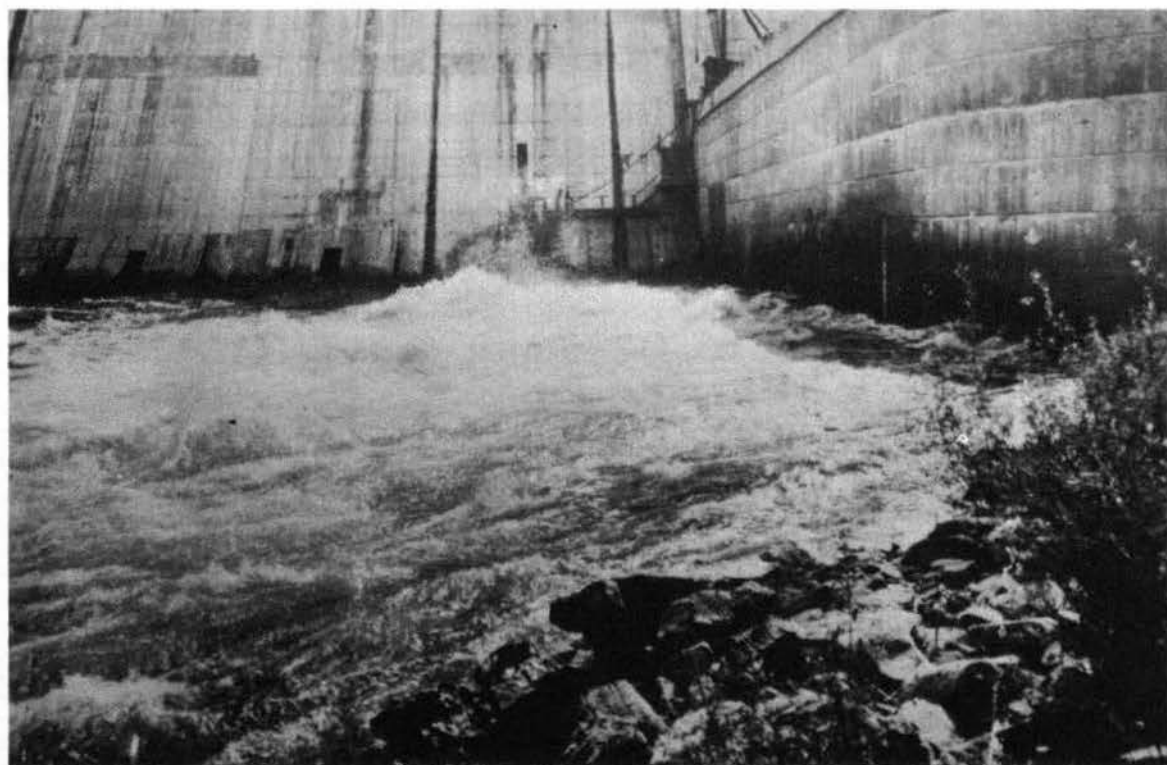

Fig. 10. Flow conditions in stilling basin downstream from test section, gate open 6.0 ft

the piezometers in the recess and along the roof of the conduit downstream (piezometers 18-30). Also, as the gate was raised, pressure readings from the piezometers located on the gate became meaningless as the piezometers fell within the gate recess. These piezometers have been indicated by means of "#" in tables 13-18.

30. No unusual phenomena were indicated by the average pressure measurements. In general, pressures were reduced as the flow moved downstream. Pressures on the floor of the conduit at part gate opening were usually lowest, or the greatest change in pressure occurred, at piezometer 9 immediately downstream from the floor seal of the gate. Pressures on the roof of the conduit were high for full gate opening, reaching a maximum of about 63 ft at piezometer 20. Typical grade line plots for 0.5-ft and full gate openings are shown on plate 13. Piezometer 31 located on the center line of the conduit about 16 ft downstream from piezometer 15 indicated a pressure rise at part gate opening for existing tailwater conditions which is evidence that a hydraulic jump tended to form in this vicinity. For full conduit flow the pressure rise was not apparent on the base of the conduit; on the roof of the conduit, however, a pressure increase was noted. This condition is probably a result of the change in alignment of the conduit roof. Of interest also are pressures at the junction of the tapered roof downstream from the gate and the conduit proper (piezometers 27 and 28). In all tests piezometer 27 gave indications of a lower pressure than piezometer 28. Since the latter piezometer was located immediately downstream from the break in alignment of the conduit roof, the results were contrary to those expected. The low pressures at piezometer 27 may have resulted from a surface irregularity produced by the seal of the auxiliary air vent located immediately upstream. The lowest pressure recorded was -2.9 ft of water for conditions of full gate opening and the 7.11 per cent orifice located on the air vent (table 18).

31. Review of the average pressure data indicates that a reduction in vent size had practically no effect until the vent was reduced by the 7.11 per cent orifice. Table 19 presents comparative data for piezometers 9-16 which were located in the floor of the conduit. The data presented

were obtained with a 3-ft gate opening, the opening at which air flow was at a maximum. It is to be noted that even with a 7.11 per cent orifice on the air vent shaft, pressures at the respective locations were decreased only about 6 ft.

32. Comparison of tables 17 and 18 (presenting average pressure data for two tailwater conditions) indicates little or no effect of reduced tailwater on pressure conditions with part gate opening. However, with the gate open 6 ft or fully open, the conduit flowed under pressure and the reduction in tailwater was accompanied by an equivalent decrease in pressure.

33. Comparison of average pressures, model and prototype. In order that a direct comparison between model and prototype data can be made, it is necessary to approximate the head on the prototype gate taking into account the conduit losses upstream from the test gate. Coefficients were determined from the model study that express the relationship between the pressure at the various piezometer locations and the total head on the gate, referred to the center line of the conduit. On the assumption that the same relationship exists between the head and the pressure at piezometer 1 in model and prototype, heads were computed utilizing model coefficient data; that is, head and pressure conditions at piezometer 1 were made to agree in model and prototype, and pressures at other piezometer points in the model were computed for equivalent head conditions on the basis of the coefficient data previously determined on the model (table 20). Equivalent head conditions that should exist in the prototype if piezometer 1 is to agree in model and prototype are shown in the following tabulation.

Computed Head on Gate Referred to Center Line of Conduit							
Gate opening, ft	0.50	0.75	1.00	2.00	3.00	4.00	5.00
Head, ft of water	177.9	177.6	177.6	174.2	171.0	164.4	151.6

Note: Heads computed from model pressure coefficient "K" and measured pressure at piezometer 1 on the prototype gate.

Example: Measured pressure "P" at piezometer 1 for a gate opening of 2.00 ft = 161.1 ft of water.

$$K = 0.925 \text{ from table 20. Head} = \frac{P}{K} = \frac{161.1}{0.925} = 174.2 \text{ ft of water.}$$

Values of the various head conditions as determined by this procedure seem reasonable. Pressures at each of the piezometer locations were computed by multiplying the heads thus determined by coefficients taken from the model study. Comparison between the adjusted model values and the pressures actually measured in the prototype is shown in table 21. Excellent agreement exists between model and prototype results. Although the lack of similar tailwater conditions in model and prototype precludes a direct comparison of model and prototype pressures with the conduit flowing full, an indication of the relative effect could be determined by the procedure described for part gate opening.

34. Instantaneous pressure measurements. Results of instantaneous pressure measurements recorded with electrical pressure cells are shown in table 22. The cell locations are shown on plate 11. Maximum, minimum, and observed average pressures are presented as taken from oscillograph records; actual reproductions of a few typical oscillograph records are shown on plates 14 and 15. Cell 8, located on one side of the gate, short-circuited and the readings were of no value. However, cell 7, located on the center line of the gate near the lip, gave readings that are believed to be reliable. The surprising result of the pressure cell readings was the lack of fluctuation at small gate openings. At the large gate openings, 4 to 6 ft, some fluctuations were recorded but in no case did they exceed approximately 25 ft of water. In most instances the degree of fluctuation was even less. Restriction of the air vent did not appear to have an appreciable effect on either magnitude of pressures or pressure fluctuation. For small gate openings average pressures were slightly negative on those cells downstream from the gate. The negative pressure values presented in table 22 for the cells located in the roof of the conduit are attributed to air requirements, because as soon as the conduit filled the roof cells gave positive readings. Comparison of the observed average pressures obtained by means of the electrical cells with those measured by the piezometers revealed somewhat similar results. Several of these comparisons are shown in graphical form on plates 16-18.

35. Vibration. Vibration data were obtained in three directions as described previously in paragraph 19. These data are presented in

tables 23-25 and plates 19-22. Also, as mentioned previously, the data represent only relative vibration; that is, the relative vibration of each plot is based on percentages of the maximum amplitude of recorded vibration, which in this case occurred in a transverse direction. Determination of vibration amplitude in terms of dimensional quantities was beyond the capabilities of the test equipment. Maximum vibration was recorded as occurring in a transverse direction at a gate opening of 6 ft. Also, for full conduit flow, the tabular data indicate that vibration was reduced as the air vent was throttled. For vibration in a transverse direction it was reduced from a maximum to zero vibration by throttling the vent. Since water was standing in the vent and no flow of air was taking place, it is again difficult to evaluate the results obtained. Although maximum vibration occurred in a transverse direction with the gate open 6 ft, the data also indicate that throughout the full range of gate openings vibration in a vertical direction (about the trunnion) was generally higher than that recorded in other directions. The inconsistencies in these data are attributed to the large, variable seal friction. Consideration was given to the use of an elastic suspension for these tests but the seal friction was so great that the gate had to be forced shut. In analyzing the vibration data, consideration should be given the fact that visual observations were possible for openings less than 5.5 ft, and in no case was vibration apparent.

36. Air flow. The equipment and methods for measuring air flow have been described in paragraph 21. The data obtained are presented in table 26 and on plate 23. Maximum air flow occurred at a gate opening of 3 ft and decreased as the gate was moved in either direction from this point. As orifice plates were placed on the vent, reducing the area of the entrance, the air flow down the vent was reduced in accordance with the loss induced by the orifice used. The applicability of these data for other installations may be somewhat limited as a result of tailwater conditions and consequent jump action within the conduit. Data indicated that lowering the tailwater several feet had practically no effect on air flow (table 26), especially for gate openings in excess of 0.75 ft.

37. Forces on lifting strut. In an effort to measure the total

downpull forces acting on the gate stem resulting from hydraulic forces and the weight of the gate, several strain gages were located on the lifting stem. The results of these data (plate 24) emphasize previous statements regarding the large seal friction value. In general, as the gate was being closed and stopped at various openings where data were recorded, the forces measured indicate the stem was in compression. The reverse was true as the gate was opened; that is, in general, the stem was in tension. Points where the forces changed from compression to tension, or vice versa, for no apparent reason are possibly the result of passing the intended opening and having to reverse the lifting mechanism to obtain the desired point.

38. Comparison of prototype data with similar model measurements (table 10) was not possible because of the side-seal friction in the prototype. Model data indicated actual downpull resulting from hydraulic forces alone was very small, being in the range of about one ton for full gate opening. At smaller gate openings the downpull was reduced.



Fig. 11. Test recesses in floor of conduit, looking upstream, after one month's intermittent operation

Supplementary cavitation tests

39. As a supplementary study to the tainter gate problem, four recesses were placed in the concrete floor of the conduit downstream from the tainter gate to study possible cavitation effect. The location and details of these recesses are shown on plate 6. At the conclusion of the initial series of tests on the tainter gates, the four re-

cesses were examined for any pitting of the surrounding concrete. Conduct of the initial series of tests required about one month of intermittent operation and at the end of this time no pitting was indicated in or downstream from any of the recesses (fig. 11).

Eccentric trunnion-type gate

40. General hydraulic performance. Hydraulic performance of the

eccentric trunnion-type gate was satisfactory for all conditions of gate opening. No vibration tendencies were noted for any condition of partial or full gate opening.

41. Vibration. Vibration data were obtained in three directions with the apparatus described in paragraph 24. The amount of acceleration was small, being in the range of 0.02 to 0.03 g for continuous gate movement. Acceleration was greatest for fixed gate settings of about 3-5 ft, although the maximum acceleration recorded was only about 0.04 g (plates 25-27). Typical vibration records are shown on plates 28-30.

42. The frequency of vibration varied from about 45 to 75 cps for all gate openings and manner of operation (plates 31-33). Assuming sinusoidal vibration, the maximum displacement of the gate in a vertical direction was only 0.0005 in., as computed from the formula $S = a/w^2$, where:

S = displacement in inches

a = acceleration in inches per sec per sec

w = 2π times frequency

43. All of the measured vibration tests were made with a rigid-pipe lifting strut. A flexible wire rope strut was also tested to determine its effect on vibration and whether or not the gate would close under its own weight. The gate was operated with the flexible strut through a complete cycle of opening and closing with stops at 1-ft intervals. The vibration was not measured with the vibration pickups but was observed from the window above the gate. No vibration was observed under any conditions of flow and the gate closed into sealing position under its own weight.

44. Forces on lifting strut. Forces on the lifting strut with and without flow passing the gate are shown on plate 34 and in tables 27 and 28. Measurements with flow passing the test gate were made for continuous motion of the gate and for each gate setting.

45. Comparison of data for continuous motion of the gate indicates that, as the gate was lifted from the closed to the open position, forces on the lifting strut were about the same whether or not flow was passing the gate. During the gate closure procedure, however, the data indicate

that some downward thrust on the lifting strut was necessary to force the gate into the high velocity flow passing through the conduit. The downward thrust required varied from about 2000 to 6000 lb. These data are not commensurate with the tests made with the flexible wire rope (paragraph 43) wherein the gate closed under its own weight. It can only be assumed that the seals (type D) used during initial tests resulted in increased friction forces. The type E seals were in place during the tests with the flexible lifting strut.

46. Forces on the lifting strut with the gate sealed in each position also are shown on plate 34. The apparently inconsistent results obtained with the gate in various sealed positions resulted from forces introduced by longitudinal movement of the gate when sealed under action of the eccentric trunnion.

Gate seals

47. The test of the hydraulic seals (fixed trunnion-type gate) indicated that they were unsatisfactory. The pressure on the interior of the seal, being the same as between the seal and the conduit surface, was not sufficient to prevent leaks. The seals permitted the gate to operate in a very satisfactory manner, and if a higher internal pressure in the seal could have been obtained it is believed that the seal would have been entirely satisfactory. The pneumatic seals (type C) were tested at various internal pressures. A small pressure inflated the seal and moved it into contact with the conduit surface, but the pressure required to actually provide a seal was about 10 to 15 lb in excess of the water pressure. The operation of the seal appeared entirely satisfactory; however, leakage could not be wholly prevented because of the unevenness of the conduit surface and the surface of the seal. Also, some difficulty was experienced with leakage at the junction of the side and top seals. It was expected that the seals might not return to their normal unsealed shape after inflation, and provisions were made for applying water pressure to the sides of the seal to cause it to return to its normal unsealed shape; however, it was found unnecessary to apply water pressure for this purpose.

48. The seals used on the eccentric trunnion-type gate operated in

a very satisfactory manner. The amount of compression of the seal was about $1/4$ in.; the tests indicated that the compression should be a little greater, probably about $3/8$ in. Some leakage was experienced with these fixed seals; however, this leakage occurred at points of irregular surfaces. Type D seals showed a smaller amount of leakage than the type E seals. It is believed, however, that either type is satisfactory for use with an eccentric trunnion gate.

PART IV: DISCUSSION AND CONCLUSIONS

49. The tests of the fixed trunnion- and eccentric trunnion-type tainter gates indicated that the hydraulic performance of either type gate was satisfactory for all conditions of gate opening. Pressure conditions, both in the gate chamber and on the fixed trunnion-type gate, were for the most part positive throughout. Pressure fluctuations were small with the largest fluctuation obtained for conditions of full gate opening. Vibration data, although inconclusive, indicated vibration amplitude (0.0005 in.) to be greatest near the fully open position. Vibration of the gate was not discernible visually. The operation of the eccentric trunnion-type gate with the flexible lifting strut was considered satisfactory. No noticeable vibration occurred and the gate lowered into sealing position under its own weight. Hoist requirements, as determined from the measurement of forces on the lifting strut, indicated that flow through the conduit contributed little to the forces involved. Forces, in addition to those required to overcome the weight of the gate, were the result of friction between the seals and the gate or walls of the conduit and were variable in nature, i.e., repeat tests under identical conditions resulted in different force values attributable only to variable friction values.

50. Air demand tests conducted with the fixed trunnion-type gate revealed that air flow was greatest for a 3-ft gate opening. Restriction of the air vent by throttling orifices, although reducing the flow of air, had practically no effect on hydraulic performance. Applicability of air flow data to other installations is believed limited in view of tailwater conditions affecting flow in the conduit and at the conduit exit portal.

51. The pneumatic seal for the fixed trunnion gate appeared satisfactory with an operating air pressure of 10 to 15 lb per sq in. greater than the water pressure from the reservoir. Initial tests wherein an effort was made to inflate the seals by use of the reservoir head were unsuccessful in stopping leakage. The results of the initial tests were responsible for the decision to construct and test the eccentric

trunnion-type gate to permit better sealing properties. Either type D or type E seal appeared satisfactory for the eccentric trunnion gate.

52. On the basis of the tests conducted at Norfork Dam on the two types of test gates, it can be concluded that:

- a. Either the fixed trunnion- or eccentric trunnion-type gate will operate satisfactorily for all conditions of gate operation.
- b. A pneumatic-type seal is required to insure sealing with the fixed trunnion-type gate. The eccentric trunnion-type gate can be sealed with either of the several types of fixed seals investigated.
- c. Care should be exercised to insure the regularity of the conduit walls and face of the gate in the vicinity of the gate seals to prevent excessive friction losses which have a direct effect on hoist requirements.

Table 1
PRESSURE DATA
GATE OPEN 0.25 FT

Piez No.	Discharge = 115.0 cfs Pressure = 199.7 ft $V^2/2g = 0.4$ ft Head = 200.1 ft		Discharge = 92.0 cfs Pressure = 149.0 ft $V^2/2g = 0.2$ ft Head = 149.2 ft		Discharge = 71.0 cfs Pressure = 99.7 ft $V^2/2g = 0.1$ ft Head = 99.8 ft		Discharge = 58.0 cfs Pressure = 75.5 ft $V^2/2g = 0.1$ ft Head = 75.6 ft		Discharge = 50.0 cfs Pressure = 49.8 ft $V^2/2g = 0.1$ ft Head = 49.9 ft		Average C
	Pressure	C	Pressure	C	Pressure	C	Pressure	C	Pressure	C	
1	195.8	0.979	146.5	0.982	96.0	0.962	72.5	0.959	46.8	0.938	0.964
2	196.9	0.984	146.6	0.983	96.1	0.963	72.5	0.959	46.8	0.938	0.965
3	196.7	0.983	146.4	0.981	96.2	0.964	72.5	0.959	46.8	0.938	0.965
5	199.7	0.998	149.4	1.001	99.3	0.995	75.3	0.996	49.6	0.994	0.997
6	199.7	0.998	149.2	1.000	99.1	0.993	75.3	0.996	49.6	0.994	0.996
7	201.7	1.008	151.2	1.013	101.6	1.018	77.9	1.030	52.4	1.050	1.024
7a	198.1	0.990	149.2	1.000	100.1	1.003	76.7	1.015	----	-----	1.002
8	176.3	0.881	132.6	0.889	89.4	0.896	68.2	0.902	----	-----	0.892
9	2.7	0.013	1.9	0.013	1.2	0.012	1.0	0.013	0.3	0.006	0.011
9a	1.2	0.006	1.2	0.008	0.9	0.009	1.0	0.013	0.8	0.016	0.010
10	-0.3	-0.001	0.1	0.001	0.2	0.002	1.2	0.016	0.2	0.004	0.004
10a	2.0	0.010	1.7	0.011	1.2	0.012	1.2	0.016	0.9	0.018	0.013
11	2.5	0.012	2.3	0.015	1.5	0.015	1.0	0.013	1.1	0.022	0.015
12	1.8	0.009	1.6	0.011	1.2	0.012	1.0	0.013	1.0	0.020	0.013
13	1.8	0.009	1.7	0.011	1.3	0.013	1.1	0.015	0.9	0.018	0.013
14	1.2	0.006	1.0	0.007	0.7	0.007	0.7	0.009	0.6	0.012	0.008
15	1.7	0.008	1.6	0.011	1.3	0.013	1.1	0.015	0.8	0.016	0.013
39	197.8	0.989	147.3	0.987	97.1	0.973	73.2	0.968	47.4	0.950	0.973
40	199.3	0.996	149.0	0.999	98.4	0.986	74.9	0.991	49.1	0.984	0.991
41	200.0	1.000	149.8	1.004	99.5	0.997	76.1	1.007	50.1	1.004	1.002
42	198.9	0.994	148.6	0.995	99.1	0.993	75.8	1.003	50.3	1.008	0.999
43	194.8	0.974	146.4	0.981	97.6	0.978	75.0	0.992	49.9	1.000	0.985
44	186.2	0.931	140.0	0.938	93.8	0.940	72.0	0.952	48.0	0.962	0.945
44a	142.0	0.710	107.5	0.721	72.3	0.724	55.6	0.735	37.2	0.745	0.727
44b	145.3	0.726	109.4	0.733	73.6	0.737	56.6	0.749	37.9	0.760	0.741

Note: Pressures are in prototype feet of water.
Piezometer locations are shown on plate 3.
Figures in heading refer to control piezometer located in the conduit 18.29 ft upstream from the gate trunnion.

$$\text{Pressure coefficient } C = \frac{\text{Pressure at numbered piezometer}}{\text{Pressure} + \frac{V^2}{2g} \text{ at control piezometer}}$$

Table 2

PRESSURE DATA

GATE OPEN 0.50 FT

Piez No.	Discharge = 197.0 cfs Pressure = 198.6 ft $V^2/2g = 1.0$ ft Head = 199.6 ft		Discharge = 156.0 cfs Pressure = 149.1 ft $V^2/2g = 0.7$ ft Head = 149.8 ft		Discharge = 133.0 cfs Pressure = 99.5 ft $V^2/2g = 0.5$ ft Head = 100.0 ft		Discharge = 113.0 cfs Pressure = 74.6 ft $V^2/2g = 0.3$ ft Head = 74.9 ft		Discharge = 89.0 cfs Pressure = 49.6 ft $V^2/2g = 0.2$ ft Head = 49.8 ft		Average C
	Pressure	C	Pressure	C	Pressure	C	Pressure	C	Pressure	C	
	1	195.6	0.980	145.9	0.974	96.7	0.967	71.8	0.959	46.9	
2	195.8	0.981	145.9	0.974	96.8	0.968	71.9	0.960	46.9	0.942	0.965
3	195.8	0.981	146.0	0.975	96.8	0.968	71.9	0.960	46.9	0.942	0.965
5	198.6	0.995	148.6	0.998	99.5	0.995	74.7	0.997	49.9	1.002	0.997
6	198.0	0.992	148.5	0.991	99.4	0.994	74.4	0.993	49.9	1.002	0.994
7	195.0	0.977	146.6	0.979	99.5	0.995	75.3	1.005	51.2	1.028	0.997
7a	182.9	0.916	137.6	0.919	93.5	0.935	70.7	0.944	48.1	0.966	0.936
8	114.2	0.572	85.0	0.567	57.0	0.570	42.8	0.571	28.9	0.580	0.572
9	2.3	0.012	2.0	0.013	1.5	0.015	1.3	0.017	1.1	0.022	0.016
9a	1.1	0.006	1.3	0.009	1.1	0.011	1.0	0.013	0.9	0.018	0.011
10	-0.2	-0.001	0.2	0.001	0.3	0.003	0.4	0.005	0.4	0.008	0.003
10a	2.3	0.012	1.8	0.012	1.5	0.015	1.2	0.016	1.0	0.020	0.015
11	3.2	0.016	2.4	0.016	1.8	0.018	1.5	0.020	1.2	0.024	0.019
12	2.3	0.012	1.8	0.012	1.4	0.014	1.3	0.017	1.1	0.022	0.015
13	2.3	0.012	1.8	0.012	1.4	0.014	1.3	0.017	1.1	0.022	0.015
14	1.1	0.006	1.1	0.007	1.0	0.010	0.9	0.012	1.0	0.020	0.011
15	2.7	0.014	2.2	0.015	1.7	0.017	1.4	0.019	1.2	0.024	0.018
39	196.2	0.983	146.3	0.977	97.5	0.975	72.2	0.964	47.3	0.950	0.970
40	197.9	0.991	147.8	0.987	99.0	0.990	74.0	0.988	49.2	0.988	0.989
41	199.2	0.998	147.0	0.981	98.8	0.988	74.1	0.989	49.7	0.998	0.991
42	191.3	0.958	143.2	0.956	96.7	0.967	72.8	0.972	48.9	0.982	0.967
43	184.3	0.923	138.4	0.924	93.4	0.934	70.4	0.940	47.4	0.952	0.935
44	170.1	0.852	127.8	0.853	86.5	0.865	65.1	0.869	44.1	0.886	0.865
44a	119.4	0.598	89.6	0.598	60.9	0.609	45.7	0.610	30.9	0.620	0.607
44b	122.1	0.612	91.5	0.611	61.8	0.618	46.6	0.622	31.4	0.631	0.619

Note: Pressures are in prototype feet of water.

Piezometer locations are shown on plate 3.

Figures in heading refer to control piezometer located in the conduit 18.29 ft upstream from the gate trunnion.

$$\text{Pressure coefficient } C = \frac{\text{Pressure at numbered piezometer}}{\text{Pressure} + \frac{V^2}{2g} \text{ at control piezometer}}$$

Table 3
PRESSURE DATA
GATE OPEN 0.75 FT

Piez No.	Discharge = 276.0 cfs Pressure = 198.1 ft $V^2/2g = 2.1$ ft Head = 200.2 ft		Discharge = 241.0 cfs Pressure = 149.1 ft $V^2/2g = 1.6$ ft Head = 150.7 ft		Discharge = 194.0 cfs Pressure = 98.5 ft $V^2/2g = 1.0$ ft Head = 99.5 ft		Discharge = 167.0 cfs Pressure = 73.5 ft $V^2/2g = 0.8$ ft Head = 74.3 ft		Discharge = 135.5 cfs Pressure = 48.6 ft $V^2/2g = 0.5$ ft Head = 49.1 ft		Average C
	Pressure	C	Pressure	C	Pressure	C	Pressure	C	Pressure	C	
	1	195.1	0.975	146.1	0.969	95.5	0.960	70.4	0.948	45.6	
2	195.6	0.977	146.8	0.974	96.0	0.965	70.5	0.949	45.7	0.931	0.959
3	195.6	0.977	147.4	0.978	96.0	0.965	70.6	0.950	45.8	0.933	0.961
5	198.6	0.992	149.8	0.994	98.7	0.992	73.3	0.986	48.6	0.990	0.991
6	197.7	0.988	148.7	0.987	99.0	0.995	73.2	0.985	48.5	0.988	0.989
7	186.1	0.930	139.8	0.928	94.3	0.948	70.4	0.947	48.3	0.984	0.947
7a	160.6	0.802	122.4	0.812	81.4	0.818	60.9	0.820	41.6	0.847	0.820
8	72.6	0.363	55.0	0.365	36.2	0.364	26.5	0.357	18.1	0.369	0.364
9	3.2	0.016	2.6	0.017	2.1	0.021	1.9	0.026	1.5	0.031	0.022
9a	0.8	0.004	1.0	0.007	1.1	0.011	1.1	0.015	1.0	0.020	0.011
10	-0.2	-0.001	0.2	0.001	0.4	0.004	0.5	0.007	0.6	0.012	0.005
10a	2.2	0.011	1.8	0.012	1.5	0.015	1.3	0.017	1.2	0.024	0.016
11	2.9	0.014	1.3	0.009	1.7	0.017	1.6	0.022	1.3	0.026	0.018
12	2.3	0.011	1.0	0.007	1.5	0.015	1.4	0.019	1.2	0.024	0.015
13	2.4	0.012	1.0	0.007	1.6	0.016	1.5	0.020	1.3	0.026	0.016
14	0.9	0.004	3.5	0.023	1.2	0.012	1.0	0.013	1.0	0.020	0.014
15	3.1	0.015	2.3	0.015	2.0	0.020	1.6	0.022	1.5	0.031	0.021
38	4.0	0.020	-----	-----	2.2	0.022	1.8	0.024	1.5	0.031	0.024
40	197.4	0.986	149.0	0.989	98.2	0.987	72.6	0.977	47.7	0.971	0.982
41	194.4	0.971	146.3	0.971	96.6	0.971	71.9	0.968	47.7	0.971	0.970
42	186.0	0.929	140.6	0.933	92.7	0.932	69.4	0.934	46.3	0.943	0.934
43	182.5	0.912	134.0	0.889	88.6	0.890	66.1	0.890	44.1	0.898	0.896
44	159.3	0.796	120.9	0.802	80.1	0.805	59.8	0.805	40.1	0.817	0.805
44a	106.7	0.533	81.3	0.539	53.7	0.540	39.9	0.537	26.8	0.546	0.539
44b	109.3	0.546	82.9	0.550	54.6	0.549	40.4	0.544	27.1	0.552	0.548

Note: Pressures are in prototype feet of water.
Piezometer locations are shown on plate 3.
Figures in heading refer to control piezometer located in the conduit 18.29 ft upstream from the gate trunnion.

$$\text{Pressure coefficient } C = \frac{\text{Pressure at numbered piezometer}}{\text{Pressure} + \frac{V^2}{2g} \text{ at control piezometer}}$$

Table 4

PRESSURE DATA

GATE OPEN 1.0 FT

Piez No.	Discharge = 374.0 cfs Pressure = 196.0 ft $V^2/2g = 3.8$ ft Head = 199.8 ft		Discharge = 315.0 cfs Pressure = 146.5 ft $V^2/2g = 2.7$ ft Head = 149.2 ft		Discharge = 257.0 cfs Pressure = 97.1 ft $V^2/2g = 1.8$ ft Head = 98.9 ft		Discharge = 218.0 cfs Pressure = 73.0 ft $V^2/2g = 1.3$ ft Head = 74.3 ft		Discharge = 179.0 cfs Pressure = 48.5 ft $V^2/2g = 0.9$ ft Head = 49.4 ft		Average C
	Pressure C	C	Pressure C	C	Pressure C	C	Pressure C	C	Pressure C	C	
1	193.0	0.966	143.5	0.962	94.1	0.951	70.1	0.943	45.5	0.921	0.949
2	194.4	0.973	144.6	0.969	94.2	0.952	70.6	0.950	45.6	0.923	0.953
3	195.1	0.976	144.6	0.969	94.7	0.958	70.6	0.950	45.7	0.925	0.956
5	197.0	0.986	146.6	0.983	96.8	0.979	73.1	0.984	48.3	0.978	0.982
6	195.1	0.976	145.5	0.975	95.9	0.970	72.7	0.978	47.9	0.970	0.974
7	174.4	0.873	131.1	0.879	87.0	0.880	66.5	0.895	44.9	0.909	0.887
7a	135.8	0.680	101.9	0.683	67.4	0.681	51.7	0.696	34.5	0.698	0.688
8	55.6	0.278	41.6	0.279	27.8	0.281	----	-----	13.9	0.281	0.280
9	4.7	0.024	4.0	0.027	3.0	0.030	3.5	0.047	2.0	0.040	0.034
9a	1.2	0.006	1.3	0.009	1.4	0.014	1.3	0.017	1.3	0.026	0.014
10	0.0	0.000	0.4	0.003	0.7	0.007	0.8	0.011	0.8	0.016	0.007
10a	2.3	0.012	2.2	0.015	1.6	0.016	1.5	0.020	1.3	0.026	0.018
11	3.0	0.015	2.5	0.017	2.0	0.020	1.7	0.023	1.3	0.026	0.020
12	2.5	0.013	2.3	0.015	1.8	0.018	1.6	0.022	1.3	0.026	0.019
13	2.6	0.013	2.3	0.015	1.9	0.019	1.7	0.023	1.5	0.030	0.020
14	1.1	0.006	1.2	0.008	1.2	0.012	1.2	0.016	1.2	0.024	0.013
15	3.5	0.018	3.0	0.020	2.3	0.023	2.1	0.028	1.7	0.034	0.025
38	5.2	0.026	4.0	0.027	2.8	0.028	2.4	0.032	1.8	0.036	0.030
40	197.6	0.989	147.6	0.989	96.4	0.975	72.6	0.977	47.5	0.961	0.978
41	191.1	0.956	143.2	0.960	94.2	0.952	71.8	0.966	47.0	0.951	0.957
42	180.8	0.905	136.0	0.912	89.4	0.904	68.1	0.916	45.0	0.911	0.910
43	170.2	0.852	127.9	0.857	84.4	0.853	64.3	0.865	42.7	0.864	0.858
44	152.4	0.763	114.1	0.765	75.3	0.761	57.3	0.771	38.0	0.769	0.766
44a	99.4	0.497	75.0	0.503	49.8	0.504	38.0	0.511	25.0	0.506	0.504
44b	102.4	0.513	76.3	0.511	49.8	0.504	38.0	0.511	25.0	0.506	0.509

Note: Pressures are in prototype feet of water.
Piezometer locations are shown on plate 3.
Figures in heading refer to control piezometer located in the conduit 18.29 ft upstream from the gate trunnion.

$$\text{Pressure coefficient } C = \frac{\text{Pressure at numbered piezometer}}{\text{Pressure} + \frac{V^2}{2g} \text{ at control piezometer}}$$

Table 5

PRESSURE DATA
GATE OPEN 2.0 FT

Piez No.	Discharge = 665.0 cfs Pressure = 187.5 ft $V^2/2g = 11.9$ ft Head = 199.4 ft		Discharge = 570.0 cfs Pressure = 142.3 ft $V^2/2g = 8.8$ ft Head = 151.1 ft		Discharge = 460.0 cfs Pressure = 94.8 ft $V^2/2g = 5.7$ ft Head = 100.5 ft		Discharge = 404.0 cfs Pressure = 72.0 ft $V^2/2g = 4.4$ ft Head = 76.4 ft		Discharge = 327.0 cfs Pressure = 47.0 ft $V^2/2g = 2.9$ ft Head = 49.9 ft		Average C
	Pressure	C	Pressure	C	Pressure	C	Pressure	C	Pressure	C	
1	184.6	0.926	139.4	0.923	91.8	0.913	69.0	0.903	44.2	0.886	0.910
2	187.6	0.941	142.4	0.942	92.8	0.923	69.5	0.910	45.1	0.904	0.924
3	190.3	0.954	143.8	0.952	94.1	0.936	70.7	0.925	45.7	0.916	0.937
5	186.3	0.934	142.2	0.941	93.7	0.932	71.3	0.933	46.9	0.940	0.936
6	181.8	0.912	138.7	0.918	90.8	0.930	69.6	0.911	45.9	0.920	0.918
7	128.0	0.642	98.0	0.649	65.0	0.647	49.9	0.653	33.5	0.671	0.652
7a	83.9	0.421	64.8	0.429	42.6	0.424	33.0	0.432	22.3	0.447	0.431
8	42.0	0.211	32.1	0.212	----	-----	16.8	0.220	11.2	0.224	0.217
9	10.8	0.054	8.7	0.058	-0.5	-0.005	0.6	0.008	4.2	0.084	0.040
9a	4.5	0.023	4.1	0.027	3.5	0.035	3.1	0.041	2.6	0.052	0.036
10	1.7	0.009	2.0	0.013	2.0	0.020	2.0	0.026	1.9	0.038	0.021
10a	3.2	0.016	2.8	0.019	2.5	0.025	2.3	0.030	2.1	0.042	0.026
11	3.0	0.015	2.7	0.018	2.3	0.023	2.2	0.029	2.0	0.040	0.025
12	3.0	0.015	2.7	0.018	2.4	0.024	2.3	0.030	2.1	0.042	0.026
13	3.5	0.018	3.1	0.021	2.7	0.027	2.4	0.031	2.2	0.044	0.028
14	2.0	0.010	2.0	0.013	2.1	0.021	2.0	0.026	2.0	0.040	0.022
15	4.5	0.023	3.8	0.025	3.2	0.032	2.7	0.035	2.3	0.046	0.032
37	-2.0	-0.010	-1.1	-0.007	-0.1	-0.001	0.2	0.003	0.5	0.010	-0.001
38	10.7	0.054	8.5	0.056	6.2	0.062	5.2	0.068	3.8	0.076	0.063
40	190.9	0.957	145.4	0.962	94.3	0.938	71.4	0.935	45.9	0.920	0.942
41	192.1	0.963	146.6	0.970	95.3	0.948	72.8	0.953	47.3	0.948	0.956
42	176.0	0.883	134.7	0.891	88.1	0.877	67.0	0.877	43.8	0.878	0.881
43	162.0	0.812	124.3	0.823	81.4	0.810	62.1	0.813	40.6	0.814	0.814
44	139.5	0.700	108.7	0.719	71.3	0.709	54.5	0.713	35.6	0.713	0.711
44a	88.7	0.445	70.0	0.463	46.1	0.459	34.8	0.455	22.7	0.455	0.455
44b	89.1	0.447	69.4	0.459	45.5	0.453	34.2	0.448	22.1	0.443	0.450

Note: Pressures are in prototype feet of water.
Piezometer locations are shown on plate 3.
Figures in heading refer to control piezometer located in the conduit 18.29 ft upstream from the gate trunnion.

$$\text{Pressure coefficient } C = \frac{\text{Pressure at numbered piezometer}}{\text{Pressure} + \frac{V^2}{2g} \text{ at control piezometer}}$$

Table 6

PRESSURE DATA
GATE OPEN 3.0 FT

Piez No.	Discharge = 993.0 cfs Pressure = 173.6 ft $V^2/2g = 26.6$ ft Head = 200.2 ft		Discharge = 855.0 cfs Pressure = 129.5 ft $V^2/2g = 19.7$ ft Head = 149.2 ft		Discharge = 705.0 cfs Pressure = 86.9 ft $V^2/2g = 13.4$ ft Head = 100.3 ft		Discharge = 589.0 cfs Pressure = 66.5 ft $V^2/2g = 9.4$ ft Head = 75.9 ft		Discharge = 520.0 cfs Pressure = 51.7 ft $V^2/2g = 7.3$ ft Head = 59.0 ft		Average C
	Pressure	C	Pressure	C	Pressure	C	Pressure	C	Pressure	C	
	1	172.1	0.860	126.9	0.851	84.1	0.838	63.9	0.842	49.1	
2	177.9	0.889	131.7	0.883	87.5	0.872	65.8	0.867	51.0	0.864	0.875
3	183.0	0.914	135.6	0.909	89.6	0.893	68.2	0.899	52.5	0.890	0.901
5	172.4	0.861	128.9	0.864	85.8	0.855	65.9	0.868	51.4	0.871	0.864
6	160.0	0.799	119.7	0.802	80.2	0.800	61.1	0.805	48.3	0.819	0.805
7	97.7	0.488	73.7	0.494	50.4	0.502	38.7	0.510	30.6	0.519	0.503
7a	67.7	0.338	51.0	0.342	34.8	0.347	26.9	0.354	21.3	0.361	0.348
8	41.4	0.207	31.5	0.211	----	-----	16.5	0.217	13.3	0.225	0.215
9	16.5	0.082	13.0	0.087	9.4	0.094	7.9	0.104	6.7	0.114	0.096
9a	8.8	0.044	7.4	0.050	5.7	0.057	5.1	0.067	4.5	0.076	0.059
10	4.2	0.021	4.0	0.027	3.4	0.034	3.3	0.043	3.0	0.051	0.035
10a	3.6	0.018	3.4	0.023	3.0	0.030	2.8	0.037	2.5	0.042	0.030
11	2.4	0.012	2.5	0.017	2.3	0.023	2.3	0.030	2.2	0.037	0.024
12	2.7	0.013	2.7	0.018	2.4	0.024	2.4	0.032	2.3	0.039	0.025
13	3.6	0.018	3.3	0.022	3.0	0.030	2.7	0.036	2.5	0.042	0.030
14	2.3	0.011	2.4	0.016	2.3	0.023	2.4	0.032	2.3	0.039	0.024
15	4.3	0.021	4.0	0.027	3.3	0.033	3.2	0.042	2.7	0.046	0.034
36	14.2	0.071	10.1	0.068	7.0	0.070	5.2	0.069	4.1	0.069	0.069
37	3.0	0.015	5.5	0.023	2.0	0.020	2.2	0.029	2.3	0.039	0.025
38	-----	-----	13.5	0.090	9.7	0.097	8.0	0.105	6.6	0.112	0.101
41	188.6	0.942	140.3	0.940	93.2	0.929	70.9	0.934	54.9	0.931	0.935
42	185.1	0.925	137.4	0.921	92.2	0.919	70.3	0.926	54.7	0.927	0.924
43	170.1	0.850	126.9	0.851	85.9	0.856	65.0	0.856	50.7	0.859	0.854
44	146.6	0.732	110.2	0.739	73.7	0.735	56.4	0.743	43.6	0.739	0.738
44a	93.1	0.465	70.8	0.475	47.0	0.469	35.6	0.469	27.6	0.468	0.469
44b	90.9	0.454	67.4	0.452	44.9	0.448	34.4	0.453	26.7	0.453	0.452

Note: Pressures are in prototype feet of water.
Piezometer locations are shown on plate 3.
Figures in heading refer to control piezometer located in the conduit 18.29 ft upstream from the gate trunnion.

$$\text{Pressure coefficient } C = \frac{\text{Pressure at numbered piezometer}}{\text{Pressure} + \frac{V^2}{2g} \text{ at control piezometer}}$$

Table 7

PRESSURE DATA
GATE OPEN 4.0 FT

Piez No.	Discharge = 1327.0 cfs Pressure = 154.3 ft $V^2/2g = 47.5$ ft Head = 201.8 ft		Discharge = 1140.0 cfs Pressure = 114.6 ft $V^2/2g = 35.0$ ft Head = 149.6 ft		Discharge = 933.0 cfs Pressure = 76.3 ft $V^2/2g = 23.5$ ft Head = 99.8 ft		Discharge = 810.0 cfs Pressure = 57.9 ft $V^2/2g = 17.7$ ft Head = 75.6 ft		Discharge = 635.0 cfs Pressure = 38.3 ft $V^2/2g = 10.9$ ft Head = 49.2 ft		Average C
	Pressure C	Pressure C	Pressure C	Pressure C	Pressure C	Pressure C	Pressure C	Pressure C			
1	151.3	0.750	113.7	0.760	74.3	0.744	56.2	0.743	35.8	0.728	0.745
2	161.1	0.798	120.4	0.805	79.3	0.795	59.9	0.792	38.1	0.774	0.793
3	174.6	0.865	130.0	0.869	85.6	0.858	64.2	0.849	41.1	0.835	0.855
5	152.9	0.758	114.3	0.764	75.8	0.760	58.3	0.771	37.9	0.770	0.765
6	131.6	0.652	100.0	0.668	65.4	0.655	50.4	0.667	33.0	0.671	0.663
7	81.9	0.406	63.0	0.421	41.8	0.419	32.9	0.435	23.2	0.472	0.431
7a	61.5	0.305	47.2	0.316	31.9	0.320	25.4	0.336	17.4	0.354	0.326
8	43.4	0.215	33.5	0.224	22.7	0.227	17.9	0.237	13.0	0.264	0.233
9	23.0	0.114	18.4	0.123	13.0	0.130	10.7	0.142	8.3	0.169	0.136
9a	14.3	0.071	11.8	0.079	9.1	0.091	7.8	0.103	6.3	0.128	0.094
10	8.8	0.044	7.7	0.051	6.3	0.063	5.5	0.073	4.7	0.096	0.065
10a	5.8	0.029	5.6	0.037	4.6	0.046	4.4	0.058	3.9	0.079	0.050
11	3.7	0.018	3.8	0.025	3.6	0.036	3.6	0.048	3.4	0.069	0.039
12	3.6	0.018	3.7	0.025	3.5	0.035	3.5	0.046	3.3	0.067	0.038
13	4.2	0.021	4.3	0.029	3.9	0.039	4.0	0.053	3.7	0.075	0.043
14	3.3	0.016	3.6	0.024	3.4	0.034	3.5	0.046	3.4	0.069	0.038
15	5.3	0.026	5.0	0.033	4.3	0.043	4.3	0.057	3.9	0.079	0.048
35	16.1	0.080	12.1	0.081	8.4	0.084	6.6	0.087	4.3	0.087	0.084
36	18.5	0.092	13.8	0.092	9.8	0.098	8.2	0.108	6.0	0.122	0.102
37	14.2	0.070	11.7	0.078	8.6	0.086	7.2	0.095	5.7	0.116	0.089
38	24.4	0.121	19.2	0.128	13.6	0.136	11.2	0.148	8.3	0.169	0.140
42	182.6	0.905	134.7	0.900	90.6	0.908	67.5	0.893	44.2	0.898	0.901
43	183.1	0.907	140.4	0.939	92.9	0.931	70.7	0.935	37.1	0.754	0.893
44	169.9	0.842	125.5	0.839	84.7	0.849	64.6	0.854	40.9	0.831	0.843
44a	110.1	0.546	84.5	0.565	56.0	0.561	42.5	0.562	28.1	0.571	0.561
44b	107.4	0.532	78.8	0.527	51.6	0.517	38.7	0.512	26.0	0.528	0.523

Note: Pressures are in prototype feet of water.
Piezometer locations are shown on plate 3.
Figures in heading refer to control piezometer located in the conduit 18.29 ft upstream from the gate trunnion.

$$\text{Pressure coefficient } C = \frac{\text{Pressure at numbered piezometer}}{\text{Pressure} + \frac{V^2}{2g} \text{ at control piezometer}}$$

Table 8

PRESSURE DATA
GATE OPEN 5.0 FT

Piez No.	Discharge = 1650.0 cfs Pressure = 99.6 ft $V^2/2g = 73.4$ ft Head = 173.0 ft		Discharge = 1538.0 cfs Pressure = 85.6 ft $V^2/2g = 63.8$ ft Head = 149.4 ft		Discharge = 1155.0 cfs Pressure = 47.8 ft $V^2/2g = 36.0$ ft Head = 83.8 ft		Discharge = 1072.0 cfs Pressure = 43.0 ft $V^2/2g = 31.0$ ft Head = 74.0 ft		Average c
	Pressure	C	Pressure	C	Pressure	C	Pressure	C	
	1	99.0	0.572	83.6	0.560	46.9	0.560	41.1	
2	109.9	0.635	92.8	0.621	50.5	0.603	44.6	0.603	0.616
3	139.0	0.803	115.3	0.772	63.9	0.763	55.5	0.750	0.772
5	100.6	0.581	85.0	0.569	47.3	0.564	42.8	0.578	0.573
6	82.7	0.478	71.6	0.479	40.0	0.477	35.7	0.482	0.479
7	57.7	0.334	49.4	0.331	28.5	0.340	26.7	0.361	0.342
7a	47.4	0.274	40.9	0.274	23.5	0.280	21.6	0.292	0.280
8	36.9	0.213	32.3	0.216	18.8	0.224	17.4	0.235	0.222
9	23.4	0.135	22.8	0.153	13.0	0.155	12.2	0.165	0.152
9a	16.9	0.098	15.2	0.102	10.3	0.123	9.7	0.131	0.114
10	11.9	0.069	11.2	0.075	7.8	0.093	7.5	0.101	0.085
10a	8.6	0.050	8.1	0.054	6.1	0.073	6.1	0.082	0.065
11	5.8	0.034	5.5	0.037	4.7	0.056	4.8	0.065	0.048
12	5.3	0.031	5.0	0.033	4.4	0.053	4.5	0.061	0.045
13	5.6	0.032	5.4	0.036	4.7	0.056	4.8	0.065	0.047
14	4.7	0.027	4.7	0.031	4.2	0.050	4.4	0.059	0.042
15	6.6	0.038	6.2	0.041	5.1	0.061	5.2	0.070	0.053
34	14.0	0.081	12.1	0.081	7.5	0.089	6.8	0.092	0.086
35	23.2	0.134	19.1	0.128	11.0	0.131	9.8	0.132	0.131
36	26.7	0.154	23.3	0.156	13.3	0.159	12.2	0.165	0.159
37	17.7	0.102	15.5	0.104	9.8	0.117	9.3	0.126	0.112
38	24.5	0.142	21.2	0.142	13.1	0.156	12.2	0.165	0.151
44	148.2	0.857	127.6	0.854	69.7	0.832	61.9	0.836	0.845
44a	126.0	0.728	109.8	0.735	58.0	0.692	53.4	0.722	0.719
44b	106.6	0.616	95.0	0.636	52.8	0.630	46.1	0.623	0.626

Note: Pressures are in prototype feet of water.
Piezometer locations are shown on plate 3.
Figures in heading refer to control piezometer located in the conduit 18.29 ft upstream from the gate trunnion.

$$\text{Pressure coefficient } C = \frac{\text{Pressure at numbered piezometer}}{\text{Pressure} + \frac{V^2}{2g} \text{ at control piezometer}}$$

Table 9

PRESSURE DATA
GATE OPEN 6.0 FT

Piez No.	Discharge = 1820.0 cfs Pressure = 16.7 ft $V^2/2g = 89.3$ ft Head = 106.0 ft		Discharge = 1227.0 cfs Pressure = 9.2 ft $V^2/2g = 40.6$ ft Head = 49.8 ft		Average C
	Pressure	C	Pressure	C	
1	13.0	0.123	6.2	0.124	0.124
2	14.8	0.140	6.7	0.135	0.138
3	12.5	0.118	5.2	0.104	0.111
5	17.6	0.166	9.5	0.191	0.179
6	18.1	0.171	9.5	0.191	0.181
7	21.5	0.203	13.2	0.265	0.234
7a	22.7	0.214	13.4	0.269	0.242
8	23.4	0.221	13.4	0.269	0.245
9	23.2	0.219	13.7	0.275	0.247
9a	24.1	0.227	14.0	0.281	0.254
10	24.2	0.228	14.1	0.283	0.256
10a	27.1	0.256	15.2	0.305	0.281
11	28.1	0.265	15.0	0.301	0.283
12	29.0	0.274	15.7	0.315	0.295
13	29.0	0.274	15.6	0.313	0.294
14	23.4	0.221	13.8	0.277	0.249
15	16.3	0.154	10.7	0.215	0.185
19	6.7	0.063	2.2	0.044	0.054
21	37.5	0.354	16.4	0.329	0.342
21a	37.4	0.353	16.1	0.323	0.338
22	32.5	0.307	14.2	0.285	0.296
22a	30.7	0.290	12.8	0.257	0.274
23	26.9	0.254	11.4	0.229	0.242
24	23.1	0.218	9.9	0.199	0.209
25	16.8	0.158	7.4	0.149	0.154
26	10.5	0.099	4.8	0.096	0.098
27	-9.5	-0.090	-4.4	-0.088	-0.089
28	-0.7	-0.007	-0.5	-0.010	-0.009
29	4.3	0.041	1.6	0.032	0.037
30	5.0	0.047	2.0	0.040	0.044
32	12.6	0.119	5.7	0.114	0.117
33	14.6	0.138	7.4	0.149	0.144
34	16.5	0.156	8.7	0.175	0.166
35	18.4	0.174	10.1	0.203	0.189
36	20.4	0.192	11.4	0.229	0.211
37	20.2	0.191	12.1	0.243	0.217
38	22.7	0.214	13.4	0.269	0.242

Note: Pressures are in prototype feet of water.
Piezometer locations are shown on plate 3.
Figures in heading refer to control piezometer located in the conduit
18.29 ft upstream from the gate trunnion.

$$\text{Pressure coefficient } C = \frac{\text{Pressure at numbered piezometer}}{\text{Pressure} + \frac{V^2}{2g} \text{ at control piezometer}}$$

Table 10

HYDRAULIC FORCES TENDING TO ROTATE GATE

Gate Opening ft	Total Head at Control Piezometer	Discharge cfs	Moment Arm to Dynamometer ft	Downpull due to Dry Wt of Gate lb	Total Downpull, lb			Downpull Less Dry Wt of Gate, lb			Torque on Trunnion due to Hydraulic Forces, ft lb		
					Maximum	Minimum	Computed Average	Maximum	Minimum	Computed Average	Maximum	Minimum	Computed Average
0.5	99.6	159	6.126	4363	4968	4493	4730	605	130	367	3706	796	2248
	150.4	200			5141	4363	4752	778	0	389	4766	0	2383
	200.6	237			5162	4277	4752	799	-86	389	4895	-527	2383
1.0	100.1	280	6.127	4514	5184	4601	4860	670	87	346	4105	533	2120
	150.2	345			5249	4536	4838	735	22	324	4503	135	1985
	199.5	400			5443	4385	4903	929	-129	389	5692	-790	2383
2.0	99.0	479	6.017	4817	5443	4752	5119	626	-65	302	3767	-391	1817
	149.5	591			5573	4709	5119	756	-108	302	4549	-650	1817
	199.7	697			5638	4579	5162	821	-238	345	4940	-1432	2076
3.0	102.1	740	5.778	5141	5659	4968	5270	518	-173	129	2993	-1000	745
	150.6	890			5573	4838	5227	432	-303	86	2496	-1751	497
	203.1	1032			5659	4666	5206	518	-475	65	2993	-2745	376
4.0	98.4	950	5.431	5422	5962	5594	5767	540	172	345	2933	934	1874
	152.2	1189			5875	5422	5659	453	0	237	2460	0	1287
	200.7	1362			5918	5227	5594	496	-195	172	2694	-1059	934
5.0	100.0	1264	4.978	5832	6653	5918	6307	821	86	475	4087	428	2365
	145.3	1529			6458	5724	6070	626	-108	238	3116	-538	1185
	180.5	1715			6415	5486	6026	583	-346	194	2902	-1722	966
6.0	42.8	1140	4.418	6394	7625	7344	7474	1231	950	1080	5439	4197	4771
	58.4	1333			7884	7517	7690	1490	1123	1296	6583	4961	5726
	77.2	1542			8705	7884	8273	2311	1490	1879	10,210	6583	8301

Note: Control piezometer located in the conduit 18.29 ft upstream from the gate trunnion.
 Negative values of torque indicate forces tending to open gate.
 Dynamometer location and details shown on plate 4.

Table 11

ELEVATIONS OF PIEZOMETERS INSTALLED IN CONDUIT

<u>Positioned in Roof</u>		<u>Positioned in Side</u>		<u>Positioned in Floor</u>	
<u>Piez No.</u>	<u>Piez Zero</u>	<u>Piez No.</u>	<u>Piez Zero</u>	<u>Piez No.</u>	<u>Piez Zero</u>
		<u>Upstream of Gate</u>			
1	376.2	4	373.2	7	369.1
2	375.8	5	372.8	8	368.9
3	375.3	6	372.4		
		<u>Downstream of Gate</u>			
18	383.4	31	366.3	9	368.6
19	379.3	32	375.1	10	368.3
20	374.8	33	374.0	11	367.7
21	374.6	34	373.8	12	367.4
22	374.1	35	371.8	13	367.0
23	373.7	36	370.6	14	366.4
24	373.3	37	369.6	15	365.7
25	372.7	38	369.1	16	368.6
26	372.0			17	368.6
27	371.5				
28	371.4				
29	371.2				
30	371.1				

Table 12

ELEVATIONS OF PIEZOMETERS INSTALLED ON GATE

Gate Opening ft	Piezometer Numbers and Zeros					
	39	40	41	42	43	44
0.50	374.6	372.7	371.3	370.4	370.0	369.6
0.75	375.0	373.0	371.6	370.7	370.3	369.9
1.00	375.4*	373.4	372.0	371.1	370.6	370.2
2.00	376.7*	374.7	373.3	372.3	371.8	371.4
3.00	377.9*	375.9*	374.4	373.5	373.0	372.5
4.00	379.0*	377.1*	375.6*	374.6	374.1	373.6
5.00	379.9*	378.1*	376.6*	375.6*	375.1*	374.6
5.25	380.1*	378.3*	376.9*	375.9*	375.4*	374.9
5.50	380.3*	378.6*	377.1*	376.1*	375.7*	375.2*
5.75	380.5*	378.8*	377.4*	376.4*	375.9*	375.4*
6.00	380.7*	379.0*	377.6*	376.7*	376.2*	375.7*
Full	380.8*	379.1*	377.7*	376.8*	376.3*	375.8*

Note: Piezometer locations are shown on plate 11.

*Piezometers located in gate well at opening indicated.

Table 13

PRESSURE DATA, AIR VENT UNRESTRICTED

Piez No.	Gate Opening in Feet											
	0.50	0.75	1.00	2.00	3.00	4.00	5.00	5.25	5.50	5.75	6.00	Full
1	173.8	172.6	171.2	161.1	146.4	124.1	86.7	74.2	60.0	40.0	24.9	23.6
2	174.8	173.6	172.5	163.8	150.5	129.2	91.4	77.3	61.8	39.6	20.7	18.8
3	175.3	174.1	173.5	166.0	155.7	141.2	114.0	104.0	89.3	64.0	26.0	17.5
4	175.6	174.5	172.8	162.4	145.9	121.4	83.8	70.6	56.2	36.4	21.3	20.9
5	114.2	114.9	113.2	110.1	101.8	97.1	73.3	67.4	53.4	34.6	20.3	19.6
6	97.1	97.7	96.4	92.8	84.3	77.6	56.4	54.1	43.5	32.8	24.8	26.0
7	175.7	179.7	158.7	111.4	84.2	67.2	49.5	43.2	36.4	26.9	29.1	32.3
8	93.0	61.9	48.4	37.4	37.8	37.5	33.1	30.5	27.2	21.7	31.2	35.9
9	1.6	3.0	4.5	10.5	15.9	19.9	20.8	19.9	18.3	15.1	30.3	35.5
10	5.8	5.9	6.0	6.8	8.9	11.7	13.8	13.8	13.0	11.8	32.8	38.0
11	0.9	1.2	1.5	2.5	3.3	4.7	6.5	7.1	7.5	7.9	39.4	43.3
12	0.7	0.9	1.0	1.9	2.2	3.9	5.4	6.1	6.4	7.2	41.5	44.2
13	*	*	*	1.1	*	*	4.0	4.5	5.0	5.8	41.0	42.4
14	1.7	1.5	1.4	1.3	1.5	2.3	3.4	3.8	4.2	5.1	34.7	34.9
15	-0.1	-1.0	-1.8	-1.1	-0.9	-0.1	0.8	1.4	2.1	3.6	25.1	25.3
16	3.0	3.1	4.9	12.6	18.1	21.6	22.0	21.1	19.8	17.3	32.0	37.2
17	*	*	*	*	*	*	*	*	*	*	*	*
18	**	**	**	**	**	**	**	**	**	**	9.5	18.6
19	**	**	**	**	**	**	**	**	**	**	12.6	21.4
20	**	**	**	**	**	**	**	**	**	**	44.9	62.8
21	**	**	**	**	**	**	**	**	**	**	49.5	49.2
22	**	**	**	**	**	**	**	**	**	**	46.7	46.8
23	**	**	**	**	**	**	**	**	**	**	40.6	40.5
24	**	**	**	**	**	**	**	**	**	**	37.9	38.2
25	**	**	**	**	**	**	**	**	**	**	29.5	29.8
26	**	**	**	**	**	**	**	**	**	**	20.8	21.0
27	**	**	**	**	**	**	**	**	**	**	0.9	0.3
28	**	**	**	**	**	**	**	**	**	**	4.4	3.9
29	**	**	**	**	**	**	**	**	**	**	4.8	4.8
30	**	**	**	**	**	**	**	**	**	**	18.0	18.2
31	6.9	4.8	7.5	9.1	9.2	7.6	8.0	7.6	8.4	11.7	24.3	24.5
32	**	**	**	**	**	**	**	**	**	**	17.5	26.2
33	**	**	**	**	**	**	0.7	0.8	5.1	5.8	19.7	26.0
34	**	**	**	**	**	**	2.9	5.4	5.7	6.6	20.3	26.5
35	**	**	**	**	**	6.0	12.2	15.1	15.0	12.2	23.7	29.2
36	**	**	**	**	15.3	19.6	23.8	22.5	20.4	16.2	27.0	32.0
37	**	**	**	**	6.9	14.7	16.5	15.7	14.6	11.9	26.9	32.2
38	**	0.4	0.9	7.9	14.8	19.6	20.3	19.3	17.5	14.4	29.2	34.5
39	*	*	#	#	#	#	#	#	#	#	8.9#	17.3#
40	178.5	177.0	176.0	168.9	#	#	#	#	#	#	14.0#	22.6#
41	*	*	*	*	*	#	#	#	#	#	*	*
42	173.2	168.9	164.8	156.3	156.3	148.8	#	#	#	#	16.6#	25.3#
43	*	*	*	*	*	*	#	#	#	#	17.2#	26.0#
44	153.8	144.9	138.5	127.2	127.8	133.7	132.0	115.4	#	#	17.6#	26.3#

Note: Piezometer locations are shown on plate 11.
Piezometer zeros are shown in table 11.
Pressures are recorded in feet of water.
Reservoir elevation = 550.8.
Tailwater elevations are shown on plate 12.
*Piezometers blocked.
**Piezometers are in air.
#Gate piezometers are in gate well.

Table 14

PRESSURE DATA, AIR VENT RESTRICTED BY 44.45 PER CENT ORIFICE

Piez No.	Gate Opening in Feet											
	0.50	0.75	1.00	2.00	3.00	4.00	5.00	5.25	5.50	5.75	6.00	Full
1	174.4	172.6	170.9	161.1	146.1	124.1	87.3	74.3	59.5	40.0	25.1	23.6
2	175.4	174.2	172.5	163.2	149.9	128.6	91.6	77.7	62.2	39.7	21.2	18.6
3	175.3	174.7	173.5	166.6	156.2	140.0	114.5	103.7	90.4	64.4	27.7	17.5
4	175.6	174.5	172.8	162.4	145.6	121.9	84.2	70.7	56.5	36.1	21.7	20.7
5	116.2	116.8	116.7	112.2	107.5	96.9	77.8	67.2	54.5	34.6	20.6	19.6
6	98.9	99.4	99.0	94.7	90.2	77.9	60.5	56.0	46.2	32.9	25.0	25.8
7	176.3	179.7	157.8	111.3	83.7	67.0	49.4	43.5	36.7	27.0	28.7	32.1
8	93.0	60.6	48.1	37.1	37.4	37.3	33.0	30.5	27.3	21.6	30.6	35.6
9	1.5	3.0	4.5	10.4	15.9	19.8	20.8	19.9	18.4	15.2	29.6	36.0
10	5.8	6.2	5.8	6.6	8.7	11.3	13.8	13.7	13.1	11.7	31.9	38.1
11	1.2	1.1	1.3	2.4	3.0	4.4	6.4	6.3	7.3	7.5	39.6	43.2
12	0.8	0.9	1.0	1.6	2.5	3.6	5.3	5.9	6.4	6.8	41.0	44.4
13	*	*	*	*	*	*	*	*	*	5.6	40.8	42.4
14	2.2	1.6	1.4	1.2	1.5	2.2	3.5	3.8	4.5	5.3	34.1	34.5
15	0.6	-0.6	-1.0	-1.3	-0.8	-0.3	0.8	2.0	3.0	4.8	25.3	25.1
16	2.5	3.2	5.2	12.5	18.1	21.6	22.0	21.3	19.6	16.9	31.0	37.0
17	*	*	*	*	*	*	*	*	*	*	*	*
18	**	**	**	**	**	**	**	**	**	**	8.1	18.0
19	**	**	**	**	**	**	**	**	**	**	11.3	21.1
20	**	**	**	**	**	**	**	**	**	**	40.5	62.8
21	**	**	**	**	**	**	**	**	**	**	47.9	49.0
22	**	**	**	**	**	**	**	**	**	**	45.8	45.0
23	**	**	**	**	**	**	**	**	**	**	40.7	40.2
24	**	**	**	**	**	**	**	**	**	**	38.2	38.1
25	**	**	**	**	**	**	**	**	**	**	29.6	29.4
26	**	**	**	**	**	**	**	**	**	**	20.7	20.6
27	**	**	**	**	**	**	**	**	**	**	1.0	0.7
28	**	**	**	**	**	**	**	**	**	**	4.6	4.4
29	**	**	**	**	**	**	**	**	**	**	4.9	5.0
30	**	**	**	**	**	**	**	**	**	**	18.0	18.1
31	6.4	4.6	6.9	9.5	9.2	7.4	7.7	7.7	8.5	11.9	24.2	24.7
32	**	**	**	**	**	**	**	**	**	**	15.6	26.0
33	**	**	**	**	**	**	0.7	1.0	4.8	6.1	18.6	25.5
34	**	**	**	**	**	**	3.2	5.6	5.4	7.5	19.2	26.4
35	**	**	**	**	**	5.6	11.9	15.1	14.8	12.8	22.6	28.7
36	**	**	**	**	14.9	18.2	23.8	22.3	20.0	16.1	26.0	31.7
37	**	**	**	**	7.4	14.3	16.3	15.9	14.3	12.2	25.8	32.2
38	**	0.3	1.1	7.8	14.8	19.7	20.1	19.1	17.5	14.8	28.0	34.1
39	177.1	174.4	#	#	#	#	#	#	#	#	16.9#	21.5#
40	178.5	177.6	176.0	170.7	#	#	#	#	#	#	9.9#	17.9#
41	*	*	*	*	*	#	#	#	#	#	*	*
42	173.8	168.9	164.5	*	158.0	148.3	#	#	#	#	13.9#	24.6#
43	168.4	161.2	155.7	*	147.5	148.8	#	#	#	#	15.3#	24.2#
44	154.4	144.9	138.8	127.2	130.1	131.4	128.0	114.8	#	#	16.6#	25.9#

Note: Piezometer locations are shown on plate 11.
Piezometer zeros are shown in table 11.
Pressures are recorded in feet of water.
Reservoir elevation = 550.8.
Tailwater elevations are shown on plate 12.
*Piezometers blocked.
**Piezometers are in air.
#Gate piezometers are in gate well.

Table 15

PRESSURE DATA, AIR VENT RESTRICTED BY 28.44 PER CENT ORIFICE

Piez No.	Gate Opening in Feet												
	0.50	0.75	1.00	2.00	3.00	4.00	5.00	5.25	5.50	5.75	6.00	Full	
1	174.4	172.6	170.9	162.2	146.4	125.3	86.9	73.7	59.6	40.2	24.9	23.5	
2	175.4	174.2	172.5	164.4	150.2	130.3	90.9	77.0	61.3	39.8	21.0	18.5	
3	175.9	174.7	173.5	167.8	155.9	142.4	114.1	103.9	89.8	65.2	27.1	17.4	
4	176.2	175.1	172.8	163.5	146.2	123.1	83.5	70.4	56.2	36.8	21.5	20.1	
5	115.8	116.3	119.4	111.5	106.3	98.2	77.2	67.3	54.0	34.9	20.6	19.2	
6	96.8	97.8	100.7	94.8	89.8	78.1	59.8	52.5	44.9	32.5	24.8	25.5	
7	176.3	167.6	157.8	111.6	83.8	66.9	49.2	42.9	36.4	27.0	28.8	31.7	
8	93.1	60.6	47.8	37.1	37.3	37.2	32.9	30.3	27.0	21.7	31.2	35.0	
9	1.5	2.9	4.3	10.3	15.7	19.5	20.6	19.5	18.1	15.2	30.0	35.2	
10	5.8	5.8	5.7	6.5	8.5	11.3	13.6	13.7	13.2	11.4	32.5	37.9	
11	1.0	0.9	1.2	2.1	2.8	4.0	6.1	7.0	7.3	7.3	39.2	42.9	
12	0.5	0.7	0.7	1.3	2.1	3.3	5.2	5.7	6.4	6.7	41.7	44.1	
13	*	*	*	*	*	*	*	*	*	5.6	40.8	42.2	
14	2.2	1.4	1.2	0.9	1.2	2.0	3.3	3.8	4.2	4.9	34.4	34.5	
15	0.1	-1.0	-1.1	-1.6	-1.1	-0.6	0.9	1.1	1.8	3.1	25.2	25.0	
16	2.0	3.0	5.1	12.3	17.7	21.1	21.8	20.7	19.4	16.9	32.0	36.7	
17	*	*	*	*	*	*	*	*	*	*	*	*	
18	**	**	**	**	**	**	**	**	**	**	9.6	17.9	
19	**	**	**	**	**	**	**	**	**	**	12.7	20.9	
20	**	**	**	**	**	**	**	**	**	**	41.9	63.7	
21	**	**	**	**	**	**	**	**	**	**	48.8	47.8	
22	**	**	**	**	**	**	**	**	**	**	46.1	45.1	
23	**	**	**	**	**	**	**	**	**	**	40.8	40.2	
24	**	**	**	**	**	**	**	**	**	**	38.2	38.0	
25	**	**	**	**	**	**	**	**	**	**	29.7	29.5	
26	**	**	**	**	**	**	**	**	**	**	20.9	20.6	
27	**	**	**	**	**	**	**	**	**	**	1.0	-0.5	
28	**	**	**	**	**	**	**	**	**	**	4.9	3.3	
29	**	**	**	**	**	**	**	**	**	**	5.0	4.0	
30	**	**	**	**	**	**	**	**	**	**	17.9	18.3	
31	8.7	4.1	4.1	9.0	8.4	6.4	7.5	7.5	8.1	9.9	24.3	24.6	
32	**	**	**	**	**	**	**	**	**	**	16.6	25.6	
33	**	**	**	**	**	**	0.9	0.6	4.5	5.4	19.1	25.5	
34	**	**	**	**	**	**	3.2	5.6	5.7	6.8	19.9	26.3	
35	**	**	**	**	**	5.8	11.7	14.9	14.9	12.5	23.3	28.7	
36	**	**	**	**	14.4	19.4	23.3	21.8	20.0	15.8	26.5	31.6	
37	**	**	**	**	7.5	13.9	16.2	15.4	14.2	11.5	26.6	32.4	
38	**	0.2	0.8	7.3	14.6	19.3	19.8	18.8	17.5	14.3	29.1	34.1	
39	177.1	174.4	#	#	#	#	#	#	#	#	16.4#	34.2#	
40	178.5	177.6	176.0	170.1	#	#	#	#	#	#	13.6#	22.4#	
41	*	*	*	*	*	#	#	#	#	#	*	*	
42	173.8	168.9	164.5	157.5	157.2	147.7	#	#	#	#	16.1#	24.7#	
43	168.4	161.2	155.7	147.0	146.9	145.9	#	#	#	#	16.5#	25.2#	
44	154.4	144.9	138.8	128.4	128.1	131.9	129.8	114.0	#	#	17.0#	25.7#	

Note: Piezometer locations are shown on plate 11.
Piezometer zeros are shown in table 11.
Pressures are recorded in feet of water.
Reservoir elevation = 550.8.
Tailwater elevations are shown on plate 12.
*Piezometers blocked.
**Piezometers are in air.
#Gate piezometers are in gate well.

Table 16

PRESSURE DATA, AIR VENT RESTRICTED BY 16.00 PER CENT ORIFICE

Piez No.	Gate Opening in Feet											
	0.50	0.75	1.00	2.00	3.00	4.00	5.00	5.25	5.50	5.75	6.00	Full
1	175.0	173.2	171.5	162.2	146.7	123.6	86.9	74.7	60.0	40.1	25.1	24.0
2	*	*	*	*	150.5	128.6	90.9	78.1	62.0	39.8	21.1	19.3
3	176.4	174.7	174.1	167.2	156.2	140.6	113.7	105.7	92.1	64.7	27.7	19.8
4	*	*	173.3	163.5	146.8	120.9	83.6	71.3	56.7	36.4	22.0	21.5
5	113.7	115.4	118.6	114.2	107.2	97.3	76.9	68.3	54.4	34.6	20.6	20.0
6	96.0	96.1	99.0	95.9	87.6	75.7	56.8	49.9	41.9	29.3	23.0	23.4
7	*	168.8	159.0	110.8	83.0	66.4	48.8	43.3	36.5	26.3	28.7	31.1
8	92.7	60.2	47.3	36.5	36.3	36.5	32.4	30.2	26.9	21.1	30.6	34.3
9	1.0	0.9	3.5	9.5	15.9	18.8	20.2	19.3	17.9	14.6	29.6	34.2
10	5.3	5.3	5.5	5.9	7.7	10.6	13.1	13.0	12.5	11.1	31.9	36.5
11	0.7	0.4	0.7	0.9	1.6	3.3	5.9	6.1	6.8	6.9	38.6	42.2
12	0.5	0.1	0.1	0.6	1.1	2.6	4.4	5.2	5.9	6.3	41.3	44.1
13	*	*	*	*	*	*	*	*	*	*	44.5	45.5
14	1.5	1.1	0.6	-0.1	0.1	1.1	2.8	3.3	3.8	4.6	34.2	35.1
15	0.0	-0.7	-1.1	-2.4	-2.4	-1.5	-0.1	0.9	2.1	2.8	25.3	25.2
16	1.9	2.6	4.2	*	17.3	20.4	21.7	20.9	19.2	16.1	30.9	35.7
17	*	*	*	*	*	*	*	*	*	*	*	*
18	**	**	**	**	**	**	**	**	**	**	8.2	15.9
19	**	**	**	**	**	**	**	**	**	**	11.7	18.7
20	**	**	**	**	**	**	**	**	**	**	42.8	57.8
21	**	**	**	**	**	**	**	**	**	**	48.9	50.9
22	**	**	**	**	**	**	**	**	**	**	46.2	45.8
23	**	**	**	**	**	**	**	**	**	**	40.7	40.4
24	**	**	**	**	**	**	**	**	**	**	38.2	38.7
25	**	**	**	**	**	**	**	**	**	**	29.7	29.6
26	**	**	**	**	**	**	**	**	**	**	20.5	20.4
27	**	**	**	**	**	**	**	**	**	**	0.4	0.6
28	**	**	**	**	**	**	**	**	**	**	4.3	4.4
29	**	**	**	**	**	**	**	**	**	**	4.5	4.6
30	**	**	**	**	**	**	**	**	**	**	18.1	18.1
31	7.9	7.8	7.8	7.6	7.7	6.2	6.7	7.4	8.1	10.3	24.3	24.3
32	**	**	**	**	**	**	**	**	**	**	15.7	23.6
33	**	**	**	**	**	**	0.2	0.7	4.3	4.8	18.5	24.0
34	**	**	**	**	**	**	2.6	4.9	5.6	6.2	19.7	25.1
35	**	**	**	**	**	3.8	11.8	14.8	14.1	10.6	22.7	27.3
36	**	**	**	**	13.8	18.5	23.3	22.1	19.9	15.3	26.5	30.5
37	**	**	**	**	5.2	19.5	16.3	15.4	14.0	10.8	26.2	30.6
38	**	-0.3	-0.3	7.2	13.5	18.6	19.4	18.8	17.3	13.8	28.5	32.8
39	177.7	174.4	#	#	#	#	#	#	#	#	28.8#	34.2#
40	178.9	178.2	176.0	170.7	#	#	#	#	#	#	12.9#	20.1#
41	*	*	*	*	*	#	#	#	#	#	*	*
42	174.4	170.1	165.0	158.6	158.6	146.5	#	#	#	#	15.2#	22.8#
43	169.6	162.4	156.3	147.0	148.7	144.7	#	#	#	#	15.7#	23.3#
44	155.0	145.4	138.2	127.2	129.6	130.2	129.2	117.3	#	#	16.6#	23.8#

Note: Piezometer locations are shown on plate 11.
Piezometer zeros are shown in table 11.
Pressures are recorded in feet of water.
Reservoir elevation = 550.8.
Tailwater elevations are shown on plate 12.
*Piezometers blocked.
**Piezometers are in air.
#Gate piezometers are in gate well.

Table 17

PRESSURE DATA, AIR VENT RESTRICTED BY 7.11 PER CENT ORIFICE

Piez No.	Gate Opening in Feet						
	2.00	3.00	4.00	5.00	5.50	6.00	Full
1	161.1	145.2	123.6	85.4	58.3	25.0	23.4
2	162.6	149.3	128.6	89.8	60.3	20.7	18.6
3	166.0	155.6	140.0	114.3	89.0	26.7	17.0
4	162.4	144.7	119.3	82.0	54.3	21.7	20.8
5	113.7	105.2	95.2	76.1	52.2	20.6	19.5
6	96.0	89.1	77.7	58.7	43.3	25.2	26.0
7	109.6	80.2	63.0	46.6	34.3	29.4	32.2
8	33.0	32.4	33.2	30.2	24.8	31.2	35.9
9	5.1	9.8	14.8	17.3	15.8	30.1	35.9
10	1.5	2.0	6.0	10.2	10.7	32.7	38.6
11	-3.9	-3.1	-1.8	2.8	4.8	39.2	43.4
12	-3.6	-3.8	-2.4	1.9	3.9	41.5	44.8
13	*	*	*	*	*	40.8	42.4
14	-0.7	-0.7	-3.5	0.0	1.7	34.3	34.7
15	-6.4	-6.7	-6.0	-2.5	-0.4	25.3	26.0
16	7.3	12.1	16.4	19.0	17.4	31.7	37.6
17	*	*	*	*	*	*	*
18	**	**	**	**	**	9.0	18.7
19	**	**	**	**	**	12.0	21.8
20	**	**	**	**	**	43.1	63.2
21	**	**	**	**	**	50.0	48.9
22	**	**	**	**	**	46.2	45.3
23	**	**	**	**	**	40.9	40.3
24	**	**	**	**	**	38.5	38.0
25	**	**	**	**	**	29.8	29.4
26	**	**	**	**	**	20.9	20.7
27	**	**	**	**	**	0.5	0.0
28	**	**	**	**	**	4.4	2.6
29	**	**	**	**	**	4.6	4.6
30	**	**	**	**	**	18.2	18.3
31	5.1	3.6	3.9	5.0	6.4	25.4	32.2
32	**	**	**	**	**	16.9	26.7
33	**	**	**	-1.2	2.0	19.4	26.1
34	**	**	**	0.2	2.9	20.2	27.1
35	**	**	-0.2	9.0	12.3	24.2	29.9
36	**	9.1	15.3	20.3	17.7	26.6	31.9
37	**	1.0	9.5	13.2	11.8	26.8	32.7
38	-1.5	9.3	14.5	17.0	15.2	28.5	34.6
39	#	#	#	#	#	*	*
40	170.1	#	#	#	#	13.4#	23.3#
41	*	*	#	#	#	*	*
42	155.8	155.7	148.6	#	#	15.9#	25.6#
43	144.2	144.6	146.4	#	#	*	23.8#
44	123.8	124.4	134.8	127.4	#	16.9#	27.1#

Note: Piezometer locations are shown on plate 11.
Piezometer zeros are shown in table 11.
Pressures are recorded in feet of water.
Reservoir elevation = 550.8.
Tailwater elevations are shown on plate 12.
*Piezometers blocked.
**Piezometers are in air.
#Gate piezometers are in gate well.

Table 18

PRESSURE DATA, AIR VENT RESTRICTED BY 7.11 PER CENT ORIFICE
REDUCED TAILWATER CONDITIONS

Piez No.	Gate Opening in Feet											
	0.50	0.75	1.00	2.00	3.00	4.00	5.00	5.25	5.50	5.75	6.00	Full
1	173.2	*	170.3	161.1	144.9	123.0	85.6	72.5	57.9	36.8	22.8	21.0
2	174.2	*	171.9	162.6	148.8	128.0	90.1	76.1	59.6	36.2	18.5	15.9
3	174.7	*	172.4	166.0	155.1	142.4	114.8	102.2	88.7	60.9	24.5	14.1
4	174.5	*	171.6	160.6	143.3	120.8	82.4	68.8	54.0	33.1	19.4	17.7
5	119.4	*	118.9	113.9	106.1	96.6	76.6	65.8	51.8	31.3	18.7	17.0
6	98.8	*	99.1	95.8	88.2	77.3	59.2	52.2	44.2	29.8	23.4	23.9
7	175.1	*	156.6	109.6	80.6	64.0	47.0	41.0	34.0	23.5	26.9	29.7
8	92.0	*	43.9	33.5	33.5	32.8	30.5	28.1	24.4	18.5	29.1	33.4
9	-1.1	*	-0.9	5.3	10.2	13.7	17.3	17.3	16.7	11.7	28.0	33.5
10	3.1	*	1.0	1.5	3.0	6.0	10.6	11.3	10.5	8.3	30.8	36.6
11	-2.0	*	-2.9	-1.9	-2.3	-2.3	2.8	4.0	4.2	4.0	37.1	41.2
12	-2.3	*	-4.1	-2.8	-2.9	-3.6	1.9	3.0	3.4	3.5	39.3	42.1
13	-2.6	*	-5.0	-2.9	-3.1	-3.2	0.9	1.9	2.1	2.5	39.3	39.9
14	-1.6	*	-0.7	-0.1	-0.9	-4.2	0.2	1.1	1.8	1.8	32.0	32.4
15	-2.6	*	-4.9	-3.2	-2.9	-5.5	-2.5	-1.3	-1.0	-0.2	22.9	23.3
16	-0.2	*	-0.5	8.1	12.7	17.9	19.2	18.6	17.3	13.7	29.6	35.6
17	*	*	*	*	*	*	*	*	*	*	*	*
18	**	**	**	**	**	**	**	**	**	**	6.7	16.9
19	**	**	**	**	**	**	**	**	**	**	9.9	19.8
20	**	**	**	**	**	**	**	**	**	**	41.5	62.4
21	**	**	**	**	**	**	**	**	**	**	48.2	46.4
22	**	**	**	**	**	**	**	**	**	**	44.3	43.1
23	**	**	**	**	**	**	**	**	**	**	38.9	38.1
24	**	**	**	**	**	**	**	**	**	**	36.4	36.2
25	**	**	**	**	**	**	**	**	**	**	27.8	27.4
26	**	**	**	**	**	**	**	**	**	**	18.7	18.6
27	**	**	**	**	**	**	**	**	**	**	-1.8	-2.9
28	**	**	**	**	**	**	**	**	**	**	2.2	1.2
29	**	**	**	**	**	**	**	**	**	**	2.2	1.8
30	**	**	**	**	**	**	**	**	**	**	16.1	16.2
31	6.2	*	3.7	5.3	4.2	5.5	4.3	5.4	6.2	9.0	22.1	21.0
32	**	**	**	**	**	**	**	**	**	**	14.5	25.0
33	**	**	**	**	**	**	-1.2	-0.8	2.6	2.6	17.1	24.4
34	**	**	**	**	**	**	-0.6	2.8	2.8	3.2	17.2	24.8
35	**	**	**	**	**	-1.8	8.3	12.6	12.3	9.1	21.2	27.4
36	**	**	**	**	9.6	15.3	21.0	20.1	17.6	12.7	24.6	30.1
37	**	**	**	**	1.1	8.9	14.0	13.8	12.1	8.4	24.6	30.9
38	**	*	-2.4	3.6	8.9	15.2	16.8	16.8	15.2	11.0	26.7	32.9
39	175.4	*	#	#	#	#	#	#	#	#	9.6#	19.9#
40	177.3	*	175.4	168.4	#	#	#	#	#	#	11.6#	21.4#
41	*	*	*	*	*	#	#	#	#	#	*	*
42	172.7	*	164.5	155.8	158.0	152.3	#	#	#	#	13.8#	24.0#
43	156.3	*	146.5	137.2	141.2	144.7	#	#	#	#	14.4#	23.9#
44	152.7	*	136.5	123.2	126.7	137.1	130.3	113.3	#	#	15.0#	24.9#

Note: Piezometer locations are shown on plate 11.
Piezometer zeros are shown in table 11.
Pressures are recorded in feet of water.
Reservoir elevation = 550.8.
Tailwater elevations are shown on plate 12.
*Piezometers blocked.
**Piezometers are in air.
#Gate piezometers are in gate well.

Table 19

PRESSURE DROP RESULTING FROM AIR VENT RESTRICTIONS

GATE OPEN 3 FEET

Piez No.	Percentage of Open Area in Air Vent								
	100	44.45		28.44		16.00		7.11	
	Pressure	Pressure	Drop	Pressure	Drop	Pressure	Drop	Pressure	Drop
9	15.9	15.9	0.0	15.7	0.2	15.9	0.0	9.8	6.1
10	8.9	8.7	0.2	8.5	0.4	7.7	1.2	2.0	6.9
11	3.3	3.0	0.3	2.8	0.5	1.6	1.7	-3.1	6.4
12	2.2	2.5	-0.3	2.1	0.1	1.1	1.1	-3.8	6.0
14	1.5	1.5	0.0	1.2	0.3	0.1	1.4	----	---
15	-0.9	-0.8	-0.1	-1.1	0.2	-2.4	1.5	-6.7	5.8
16	18.1	18.1	0.0	17.7	0.4	17.3	0.8	12.1	6.0
Average drop			0.0	0.3		1.1		6.2	

Note: Pressures are in feet of water.

Drop is the difference in pressure with the air vent unrestricted and with the various orifices in place.

The unrestricted vent had a diameter of 2.5 ft and an area of 4.91 sq ft.

Table 20

PRESSURE COEFFICIENTS "K" FOR COMPARISON OF MODEL
AND PROTOTYPE DATA, AIR VENT UNRESTRICTED

Piez No.	Gate Opening in Feet						
	0.50	0.75	1.00	2.00	3.00	4.00	5.00
1	0.977	0.972	0.964	0.925	0.856	0.755	0.572
2	0.977	0.976	0.971	0.942	0.886	0.802	0.635
3	0.978	0.978	0.973	0.953	0.912	0.867	0.803
5	0.997	0.993	0.985	0.938	0.863	0.761	0.581
6	0.992	0.988	0.976	0.915	0.801	0.660	0.478
7	0.978	0.929	0.876	0.646	0.491	0.414	0.334
8	0.570	0.364	0.279	0.212	0.209	0.220	0.213
9	0.013	0.017	0.026	0.056	0.085	0.119	0.135
10	0.000	0.000	0.002	0.011	0.024	0.048	0.069
11	0.016	0.012	0.016	0.017	0.015	0.022	0.034
12	0.012	0.009	0.014	0.017	0.016	0.022	0.031
13	0.012	0.010	0.014	0.020	0.020	0.025	0.032
14	0.007	0.014	0.007	0.012	0.014	0.020	0.027
15	0.015	0.015	0.019	0.024	0.024	0.030	0.038
36	*	*	*	*	0.070	0.092	0.154
37	*	*	*	*	0.019	0.074	0.102
38	*	0.020	0.027	0.055	0.090	0.125	0.142
39	0.980	-----	**	**	**	**	**
40	0.989	0.988	0.989	0.960	**	**	**
41	0.990	0.971	0.958	0.967	0.941	**	**
42	0.957	0.931	0.909	0.887	0.923	0.903	**
43	0.924	0.901	0.855	0.818	0.851	0.923	**
44	0.853	0.799	0.764	0.710	0.736	0.841	0.857

Note: $K = \frac{\text{Pressure at piezometer in feet of water}}{\text{Head at center line of conduit}}$; values shown are average of two highest head conditions shown in tables 2-8.

*Piezometers are in air.

**Piezometers are in gate well.

Table 21COMPARISON OF PRESSURES COMPUTED FROM MODEL DATA
AND PRESSURES MEASURED IN THE PROTOTYPE

Gate Open 3 ft Head, 171.0 ft			Gate Open 5 ft Head, 151.6 ft		
Piez No.	Model Pressure	Prototype Pressure	Piez No.	Model Pressure	Prototype Pressure
1	146.4	146.4	1	86.7	86.7
2	151.5	150.5	2	96.3	91.4
3	156.0	155.7	3	121.7	114.0
5	147.6	101.8	5	88.1	73.3
6	137.0	84.3	6	72.5	56.4
7	84.0	84.2	7	50.6	49.5
8	35.7	37.8	8	32.3	33.1
9	14.5	15.9	9	20.5	20.8
10	4.1	8.9	10	10.5	13.8
11	2.6	3.3	11	5.2	6.5
12	2.7	2.2	12	4.7	5.4
13	3.4	-----	13	4.9	4.0
14	2.4	1.5	14	4.1	3.4
15	4.1	-0.9	15	5.8	0.8
38	15.4	14.8	36	23.3	23.8
41	160.9	-----	37	15.5	16.5
42	157.8	156.3	38	21.5	20.3
43	145.5	-----	44	129.9	132.0
44	125.9	127.8			

Note: Pressures are in feet of water.

Table 22

PRESSURE CELL DATA

Gate Opening ft	Air Vent Unrestricted			Air Vent Restricted by 44.45 Per Cent Orifice			Air Vent Restricted by 28.44 Per Cent Orifice			Air Vent Restricted by 16.00 Per Cent Orifice			Air Vent Restricted by 7.11 Per Cent Orifice		
	Max	Min	Avg	Max	Min	Avg	Max	Min	Avg	Max	Min	Avg	Max	Min	Avg
<u>Cell 1</u>															
0.25	----	----	----	----	----	----	----	----	----	----	----	145.9	----	----	----
0.50	----	----	----	----	----	----	----	----	----	----	----	139.2	----	----	----
0.75	----	----	----	----	----	112.0	----	----	----	----	----	124.4	----	----	----
1.00	----	----	----	----	----	100.6	----	----	----	----	----	107.8	----	----	----
2.00	----	----	----	----	----	59.9	----	----	67.9	----	----	64.5	----	----	----
3.00	----	----	----	----	----	46.4	----	----	54.6	----	----	52.2	----	----	45.9
4.00	----	----	----	----	----	41.4	----	----	49.2	----	----	45.3	----	----	39.5
5.00	----	----	----	----	----	33.7	----	----	38.8	----	----	37.1	----	----	31.3
5.25	----	----	----	----	----	31.3	----	----	35.7	----	----	33.1	----	----	27.8
5.50	----	----	----	----	----	24.4	----	----	31.9	----	----	28.3	----	----	24.2
5.75	----	----	----	----	----	18.5	----	----	24.9	----	----	21.1	----	----	16.3
6.00	----	----	----	----	----	22.9	----	----	28.9	----	----	25.2	----	----	19.3
Full	----	----	----	----	----	26.6	----	----	31.6	----	----	29.2	----	----	22.8
<u>Cell 2</u>															
0.25	----	----	----	----	----	----	----	----	1.3	----	----	2.6	----	----	-3.8
0.50	----	----	----	----	----	----	----	----	0.6	----	----	1.5	----	----	-5.7
0.75	----	----	----	----	----	1.2	----	----	-0.3	----	----	1.8	----	----	-7.1
1.00	----	----	----	----	----	-0.8	----	----	-0.1	----	----	1.6	----	----	-7.0
2.00	----	----	----	----	----	1.2	3.9	-0.1	2.5	----	----	3.6	----	----	-6.0
3.00	----	----	----	----	----	7.0	7.9	3.1	5.7	----	----	7.3	0.9	-2.8	-1.0
4.00	----	----	----	11.7	3.7	7.7	11.1	7.1	9.4	----	----	11.2	6.0	4.0	5.0
5.00	----	----	----	----	----	10.4	13.3	9.3	11.6	16.1	13.0	13.4	10.7	-6.3	4.5
5.25	----	----	----	----	----	11.2	13.7	9.2	11.4	----	----	13.6	10.7	7.2	7.9
5.50	----	----	----	15.0	7.0	11.0	13.2	8.2	10.7	14.4	11.0	13.1	9.2	5.6	7.7
5.75	----	----	----	12.6	5.2	8.9	11.5	5.7	8.6	14.4	10.2	12.3	6.9	3.6	4.7
6.00	----	----	----	30.7	18.8	24.8	27.5	20.9	24.2	31.1	26.1	28.6	28.4	23.1	24.9
Full	----	----	----	32.7	23.4	28.1	34.2	28.1	31.2	45.1	41.2	43.2	33.8	27.4	29.5
<u>Cell 3</u>															
0.25	----	----	1.7	----	----	----	12.8	-2.8	5.0	----	----	4.1	2.1	-1.9	0.0
0.50	----	----	0.2	----	----	----	----	----	0.5	----	----	2.5	----	----	-2.8
0.75	----	----	0.2	----	----	7.5	----	----	-0.8	----	----	1.8	----	----	-3.5
1.00	----	----	0.2	----	----	7.1	----	----	2.0	----	----	2.1	-4.6	-6.5	-5.3
2.00	----	----	-0.1	----	----	7.8	----	----	1.7	----	----	1.8	-1.9	-6.7	-5.3
3.00	----	----	2.3	----	----	7.8	----	----	3.5	----	----	3.1	-3.5	-7.4	-5.3
4.00	----	----	2.8	----	----	8.8	----	----	3.8	----	----	4.4	-1.1	-3.3	-2.4
5.00	----	----	6.0	----	----	10.4	----	----	7.1	----	----	7.0	----	----	1.1
5.25	----	----	5.1	----	----	9.9	----	----	6.8	----	----	7.9	3.2	0.0	2.2
5.50	----	----	5.1	----	----	10.4	11.5	8.0	8.4	----	----	8.4	----	----	2.3
5.75	----	----	7.1	13.4	7.1	10.3	12.3	9.1	10.7	----	----	8.1	1.3	-3.0	0.8
6.00	----	----	26.3	34.8	7.5	21.2	33.9	30.3	30.8	----	----	30.7	25.9	21.4	23.4
Full	----	----	32.5	----	----	33.7	39.2	34.4	35.6	----	----	33.6	30.9	28.3	28.8
<u>Cell 4</u>															
0.25	----	----	-8.7	----	----	-3.8	----	----	-3.6	----	----	-3.1	----	----	-3.8
0.50	-2.4	-3.6	-2.7	----	----	-4.0	----	----	-1.1	----	----	-2.0	----	----	-4.1
0.75	----	----	-1.7	----	----	-5.3	----	----	-4.4	----	----	-1.9	----	----	-8.4
1.00	9.1	4.6	6.8	----	----	-4.1	----	----	-2.3	----	----	0.9	----	----	2.5
2.00	----	----	1.1	----	----	2.6	----	----	4.8	----	----	5.5	----	----	-2.2
3.00	----	----	2.2	----	----	3.3	----	----	3.6	----	----	4.8	----	----	-4.2

(Continued)

Note: Pressure cell locations are shown on plate 11.

Pressures are recorded in feet of water.

Reservoir elevation 550.8.

Table 22 (Continued)

Gate Opening ft	Air Vent Unrestricted			Air Vent Restricted by 44.45 Per Cent Orifice			Air Vent Restricted by 28.44 Per Cent Orifice			Air Vent Restricted by 16.00 Per Cent Orifice			Air Vent Restricted by 7.11 Per Cent Orifice		
	Max	Min	Avg	Max	Min	Avg	Max	Min	Avg	Max	Min	Avg	Max	Min	Avg
	<u>Cell 4 (Continued)</u>														
4.00	----	----	2.9	----	----	3.3	----	----	10.6	----	----	5.3	----	----	-3.0
5.00	----	----	-0.4	----	----	2.1	----	----	4.6	----	----	2.6	----	----	-4.4
5.25	----	----	0.4	----	----	0.7	----	----	3.5	----	----	1.4	----	----	-4.3
5.50	----	----	0.3	----	----	1.6	----	----	1.7	----	----	-0.8	----	----	-2.8
5.75	----	----	4.5	----	----	3.7	----	----	4.5	----	----	3.7	----	----	-2.4
6.00	16.7	7.1	11.9	17.7	9.6	13.6	16.9	9.8	13.4	19.4	12.5	16.0	13.4	0.0	6.7
Full	29.5	16.3	22.9	26.0	17.0	21.5	26.7	19.8	23.3	37.7	29.3	33.5	23.7	0.2	11.9
<u>Cell 5</u>															
0.25	----	----	-5.4	----	----	-3.6	----	----	-2.3	----	----	-2.0	----	----	-9.2
0.50	----	----	-2.8	----	----	-3.8	----	----	-1.2	----	----	-0.6	----	----	-8.3
0.75	----	----	-3.9	----	----	-3.4	----	----	-1.5	----	----	-0.2	----	----	-8.5
1.00	----	----	-3.4	----	----	-3.3	----	----	-1.3	----	----	0.3	----	----	-7.7
2.00	----	----	-1.0	----	----	-2.1	----	----	0.3	----	----	2.2	----	----	-8.3
3.00	----	----	-2.3	----	----	-3.6	----	----	-1.4	----	----	0.4	----	----	-8.7
4.00	----	----	-2.2	----	----	-3.5	----	----	-3.8	----	----	0.1	----	----	-8.1
5.00	----	----	-2.2	----	----	-4.3	----	----	-2.3	----	----	-0.4	----	----	-6.5
5.25	----	----	-3.9	----	----	-4.8	----	----	-3.6	----	----	0.8	----	----	-6.2
5.50	----	----	-3.1	----	----	-3.8	----	----	-5.6	----	----	0.8	----	----	-6.0
5.75	----	----	-3.3	----	----	-2.9	----	----	-5.1	----	----	-0.7	----	----	-6.1
6.00	64.6	35.1	49.8	51.7	31.1	41.4	50.1	28.8	39.4	55.4	29.5	42.5	46.3	26.1	36.2
Full	59.6	33.7	46.6	48.0	32.6	40.3	48.8	34.0	41.4	54.5	31.9	43.2	41.4	26.1	33.7
<u>Cell 6</u>															
0.25	----	----	----	----	----	----	----	----	-3.0	----	----	-3.8	----	----	-1.3
0.50	----	----	----	----	----	----	----	----	-2.0	----	----	-4.1	----	----	-1.4
0.75	----	----	----	----	----	----	----	----	-4.2	----	----	-3.1	----	----	1.3
1.00	----	----	----	----	----	-13.7	----	----	-3.7	----	----	-1.5	----	----	-3.8
2.00	----	----	----	----	----	-13.3	----	----	-2.6	----	----	-1.3	----	----	-4.5
3.00	----	----	----	----	----	-12.9	----	----	-4.5	----	----	2.8	----	----	-3.7
4.00	----	----	----	----	----	-14.3	----	----	-5.3	----	----	-4.1	----	----	-3.5
5.00	----	----	----	----	----	-14.7	----	----	-4.4	----	----	-4.5	----	----	-5.3
5.25	----	----	----	----	----	-14.3	----	----	-5.0	----	----	-1.6	----	----	-3.8
5.50	----	----	----	----	----	-9.7	----	----	-5.2	----	----	-2.4	----	----	-4.6
5.75	----	----	----	----	----	-8.6	----	----	-5.5	----	----	0.3	----	----	-7.6
6.00	----	----	----	84.9	22.3	53.6	50.9	29.7	40.3	45.4	30.2	37.8	48.7	27.7	38.2
Full	----	----	----	38.1	23.0	30.6	46.4	29.8	38.1	45.7	32.7	39.2	40.4	28.6	34.5
<u>Cell 7</u>															
0.25	----	----	67.2												
0.50	----	----	55.5												
0.75	----	----	48.0												
1.00	----	----	44.0												
2.00	----	----	35.9												
3.00	----	----	36.2												
4.00	45.2	28.3	36.7												
5.00	57.1	30.9	44.0												
5.25	64.6	37.8	51.2												
5.50	61.5	29.8	45.7												
5.75	62.2	18.8	40.5												
6.00	18.0	2.8	10.4												
Full	----	----	-3.3												

Note: Pressure cell locations are shown on plate 11.

Pressures are recorded in feet of water.

Reservoir elevation 550.8.

Table 23

VIBRATION DATA, TRANSVERSE DIRECTION

Gate Opening, ft	Relative Vibration									
	Air Vent Unrestricted		Air Vent Restricted by 44.45 Per Cent Orifice		Air Vent Restricted by 28.44 Per Cent Orifice		Air Vent Restricted by 16.00 Per Cent Orifice		Air Vent Restricted by 7.11 Per Cent Orifice	
	Gate Being Opened	Gate Being Closed	Gate Being Opened	Gate Being Closed	Gate Being Opened	Gate Being Closed	Gate Being Opened	Gate Being Closed	Gate Being Opened	Gate Being Closed
0.25	-----	36.4	-----	9.1	-----	9.1	---	36.4	0.0	0.0
0.50	45.5	27.3	9.1	27.3	9.1	9.1	9.1	18.2	9.1	9.1
0.75	45.5	36.4	27.3	45.5	9.1	100.0	9.1	9.1	9.1	9.1
1.00	36.4	36.4	27.3	36.4	18.2	91.0	9.1	18.2	0.0	0.0
2.00	63.6	54.6	45.5	54.6	63.6	91.0	18.2	18.2	9.1	0.0
3.00	27.3	45.5	36.4	27.3	9.1	81.8	9.1	18.2	9.1	0.0
4.00	27.3	18.2	27.3	27.3	9.1	81.8	9.1	18.2	9.1	0.0
5.00	27.3	45.5	36.4	27.3	9.1	81.8	9.1	27.3	0.0	0.0
5.25	45.5	36.4	45.5	36.4	9.1	72.7	9.1	27.3	0.0	9.1
5.50	27.3	18.2	36.4	36.4	9.1	36.4	9.1	18.2	0.0	0.0
5.75	18.2	27.3	18.2	18.2	18.2	81.8	9.1	36.4	0.0	9.1
6.00	100.0	100.0	100.0	91.0	9.1	9.1	9.1	18.2	0.0	0.0
Full	91.0	91.0	100.0	100.0	18.2	81.8	9.1	9.1	0.0	9.1

Note: Accelerometer location shown on plate 6.
Relative vibration is per cent of maximum vibration in a transverse direction.

Table 24

VIBRATION DATA, LONGITUDINAL DIRECTION

Gate Opening, ft	Relative Vibration									
	Air Vent Unrestricted		Air Vent Restricted by 44.45 Per Cent Orifice		Air Vent Restricted by 28.44 Per Cent Orifice		Air Vent Restricted by 16.00 Per Cent Orifice		Air Vent Restricted by 7.11 Per Cent Orifice	
	Gate Being Opened	Gate Being Closed	Gate Being Opened	Gate Being Closed	Gate Being Opened	Gate Being Closed	Gate Being Opened	Gate Being Closed	Gate Being Opened	Gate Being Closed
0.25	----	9.1	----	9.1	----	18.2	----	27.3	0.0	9.1
0.50	9.1	9.1	9.1	9.1	9.1	9.1	9.1	9.1	9.1	9.1
0.75	9.1	9.1	9.1	9.1	18.2	9.1	9.1	18.2	9.1	9.1
1.00	9.1	9.1	9.1	9.1	45.5	9.1	9.1	18.2	45.5	9.1
2.00	9.1	9.1	9.1	9.1	27.3	9.1	9.1	36.4	9.1	9.1
3.00	9.1	9.1	9.1	9.1	45.5	9.1	18.2	9.1	9.1	9.1
4.00	27.3	18.2	27.3	27.3	54.6	27.3	18.2	36.4	54.6	27.3
5.00	9.1	9.1	9.1	9.1	36.4	9.1	9.1	9.1	9.1	9.1
5.25	9.1	9.1	9.1	9.1	27.3	9.1	18.2	9.1	9.1	0.0
5.50	9.1	9.1	9.1	9.1	45.5	9.1	9.1	18.2	9.1	0.0
5.75	9.1	9.1	9.1	9.1	36.4	9.1	18.2	18.2	9.1	0.0
6.00	27.3	27.3	27.3	36.4	63.6	18.2	9.1	9.1	9.1	9.1
Full	27.3	27.3	18.2	36.4	36.4	54.6	9.1	9.1	9.1	9.1

Note: Accelerometer location shown on plate 6.

Relative vibration is per cent of maximum vibration in a transverse direction.

Table 25

VIBRATION DATA, VERTICAL DIRECTION

Gate Opening, ft	Relative Vibration									
	Air Vent Unrestricted		Air Vent Restricted by 44.45 Per Cent Orifice		Air Vent Restricted by 28.44 Per Cent Orifice		Air Vent Restricted by 16.00 Per Cent Orifice		Air Vent Restricted by 7.11 Per Cent Orifice	
	Gate Being Opened	Gate Being Closed	Gate Being Opened	Gate Being Closed	Gate Being Opened	Gate Being Closed	Gate Being Opened	Gate Being Closed	Gate Being Opened	Gate Being Closed
0.25	----	63.6	----	81.8	----	63.6	----	72.7	54.6	54.6
0.50	81.8	54.6	72.7	81.8	63.6	54.6	54.6	63.6	45.5	63.6
0.75	54.6	63.6	81.8	81.8	72.7	63.6	45.5	54.6	54.6	54.6
1.00	54.6	72.7	91.0	72.7	54.6	72.7	63.6	45.5	45.5	54.6
2.00	72.7	54.6	63.6	63.6	54.6	72.7	54.6	54.6	45.5	54.6
3.00	54.6	72.7	91.0	54.6	54.6	54.6	54.6	54.6	45.5	54.6
4.00	54.6	63.6	81.8	72.7	45.5	72.7	63.6	45.5	54.6	54.6
5.00	63.6	63.6	63.6	72.7	54.6	63.6	54.6	45.5	54.6	45.5
5.25	63.6	54.6	54.6	81.8	63.6	63.6	63.6	54.6	54.6	45.5
5.50	91.0	45.5	63.6	72.7	54.6	72.7	54.6	54.6	45.5	54.6
5.75	54.6	63.6	63.6	63.6	63.6	63.6	45.5	63.6	45.5	54.6
6.00	81.8	63.6	81.8	81.8	54.6	81.8	63.6	63.6	63.6	63.6
Full	72.7	81.8	72.7	63.6	54.6	54.6	72.7	63.6	45.5	72.7

Note: Accelerometer location shown on plate 6.

Relative vibration is per cent of maximum vibration in a transverse direction.

Table 26

AIR FLOW

Gate Opening ft	Air Vent in Per Cent of Full Open Area					
	<u>100.00</u>	<u>44.45</u>	<u>28.44</u>	<u>16.00</u>	<u>7.11</u>	<u>7.11*</u>
0.25	---	49	26	20	---	43
0.50	101	89	99	71	57	75
0.75	142	113	108	87	92	91
1.00	156	120	127	117	102	103
2.00	161	132	150	125	118	114
3.00	179	159	145	148	125	116
4.00	148	147	135	127	119	109
5.00	114	102	103	88	89	80
5.25	90	89	90	84	79	72
5.50	90	85	86	79	76	68
5.75	101	106	94	96	85	84

Note: Air flow is in cubic feet per second at atmospheric pressure.
 *Low tailwater condition.

Table 27

FORCES ON LIFTING STRUT WITHOUT FLOW THROUGH CONDUIT
ECCENTRIC TRUNNION-TYPE GATE

Run No.	Gate Opening	Force, lb			Remarks	Run No.	Gate Opening	Force, lb			Remarks
		Ring A	Ring B	Average				Ring A	Ring B	Average	
1	0.25	8800	8400	8600	Closed to open	4	6.00	5200	5200	5200	Open to closed
	0.50	7500	7100	7300			5.00	3600	4000	3800	
	1.00	7150	6800	6980			4.00	3200	3200	3200	
	2.00	7000	6800	6900			3.00	2400	2800	2600	
	3.00	6100	6000	6050			2.00	1400	1600	1500	
	4.00	6800	6760	6780			1.00	-400	160	-120	
	5.00	6720	6900	6810			0.50	-1600	-1200	-1400	
	6.00	5100	5400	5250			0.25	-2400	-2000	-2200	
2	6.00	4900	5200	5050	Open to closed	5	0.00	11,200	9600	10,400	Closed to open
	5.00	2100	2900	2500			0.25	10,600	8800	9700	
	4.00	1100	2000	1550			0.50	9760	8240	9000	
	3.00	800	1800	1300			1.00	9800	8000	8900	
	2.00	-200	1160	480			2.00	11,200	9200	10,200	
	1.00	-1600	-200	-900			3.00	9000	7200	8100	
	0.50	-1000	-1400	-1250			4.00	8872	7200	8036	
	0.25	-1640	-1960	-1800			5.00	9200	7200	8200	
3	0.00	----	----	----	Closed to open	6	6.00	5600	4400	5000	Open to closed
	0.25	8800	8800	8800			5.00	4400	3200	3800	
	0.50	7600	8000	7800			4.00	4000	3200	3600	
	1.00	6800	7200	7000			3.00	3800	2980	3390	
	2.00	6400	6800	6600			2.00	3200	2400	2800	
	3.00	5200	4520	4860			1.00	800	400	600	
	4.00	5600	5600	5600			0.50	-1200	-1400	-1300	
	5.00	5600	5600	5600			0.25	-2200	-2400	-2300	
6.00	5200	6000	5600	0.00	-2600	-2400	-2500				

Note: Negative forces indicate the lifting strut is in compression.
All measurements made for continuous motion of gate.

Table 28

VIBRATION AND FORCE CHARACTERISTICS WITH FLOW THROUGH CONDUIT

ECCENTRIC TRUNNION-TYPE GATE

Run No.	Gate Opening	Vibration						Force, lb			Remarks
		Vertical		Longitudinal		Transverse		Ring A	Ring B	Average	
		Max g	Freq cps	Max g	Freq cps	Max g	Freq cps				
1	6.00	-----	----	-----	----	-----	----	7200	4400	5800	Continuous motion, open to closed
	5.00	-----	----	-----	----	-----	----	1600	-200	700	
	4.00	-----	----	-----	----	-----	----	-800	-1800	-1300	
	3.00	-----	----	-----	----	-----	----	-2400	-3200	-2800	
	2.00	-----	----	-----	----	-----	----	-4400	-5000	-4700	
	1.00	-----	----	-----	----	-----	----	-7200	-7800	-7500	
	0.50	-----	----	-----	----	-----	----	-9600	-9800	-9500	
	0.25	-----	----	-----	----	-----	----	-11,400	-11,400	-11,400	
0.00	-----	----	-----	----	-----	----	-22,400	-20,800	-21,600		
2	6.00	-----	----	-----	----	-----	----	7200	5200	6200	Gate sealed in position indicated, open to closed
	5.00	0.0400	28.5	-----	----	0.0300	28.5	10,800	8000	9400	
	4.00	0.0200	34.2	0.045	68.4	0.0325	57.0	4000	3200	3600	
	3.00	0.0200	45.6	0.040	57.0	0.0200	57.0	800	800	800	
	2.00	0.0050	51.3	0.025	68.4	0.0100	51.3	400	000	200	
	1.00	0.0025	----	0.005	68.4	0.0025	----	000	-800	-400	
	0.50	0.0050	----	0.010	74.1	0.0075	----	-400	-800	-600	
3	1.00	0.0000	----	0.015	57.0	0.0100	68.4	18,400	14,240	16,230	Gate sealed in position indicated, closed to open
	2.00	0.0125	74.1	0.020	68.4	-----	----	14,960	10,800	12,880	
	3.00	0.0200	57.0	0.040	51.3	-----	----	13,800	10,000	11,900	
	4.00	0.0350	34.2	0.035	51.3	-----	----	13,280	9600	11,440	
	5.00	0.0450	28.5	0.015	45.6	-----	----	13,600	9760	11,680	
	6.00	0.0150	62.7	-----	----	-----	----	8000	4800	6400	

(Continued)

Note: Negative forces indicate the lifting strut is in compression.

Table 28 (Continued)

Run No.	Gate Opening	Vibration						Force, lb			Remarks
		Vertical		Longitudinal		Transverse		Ring A	Ring B	Average	
		Max g	Freq cps	Max g	Freq cps	Max g	Freq cps				
4	6.00	-----	-----	-----	-----	-----	-----	7360	4400	5880	Continuous motion, open to closed
	5.00	0.0150	62.7	0.015	57.0	-----	-----	4000	1600	2800	
	4.00	0.0150	68.4	0.020	57.0	-----	-----	1200	000	600	
	3.00	0.0150	68.4	0.030	57.0	-----	-----	-1600	-2400	-2000	
	2.00	0.0150	68.4	-----	-----	-----	-----	-3400	-4000	-3700	
	1.00	0.0200	39.9	0.005	-----	-----	-----	-7200	-7200	-7200	
	0.50	0.0150	68.4	0.005	57.0	-----	-----	-9800	-9600	-9700	
5	0.50	0.0100	62.7	0.015	57.0	-----	-----	-1400	-2000	-1700	Gate sealed in position indicated, open to closed
	0.25	0.0100	51.3	0.015	68.4	-----	-----	-800	-1440	-1120	
	0.00	0.0050	57.0	0.015	68.4	-----	-----	-13,000	-12,800	-12,900	
6	0.25	0.0050	62.7	0.015	62.7	-----	-----	24,000	18,000	21,000	Gate sealed in position indicated
7	1.00	0.0050	45.6	0.015	57.0	-----	-----	7200	10,400	8800	Continuous motion, closed to open
	2.00	0.0050	45.6	0.015	62.7	-----	-----	11,840	7600	9720	
	3.00	0.0050	45.6	0.030	57.0	-----	-----	10,400	6800	8600	
	4.00	0.0050	39.9	0.020	57.0	-----	-----	9000	5440	7220	
	5.00	0.0050	39.9	-----	-----	-----	-----	9600	5600	7600	
	6.00	0.0050	57.0	-----	-----	-----	-----	8400	4800	6600	

Note: Negative forces indicate the lifting strut is in compression.

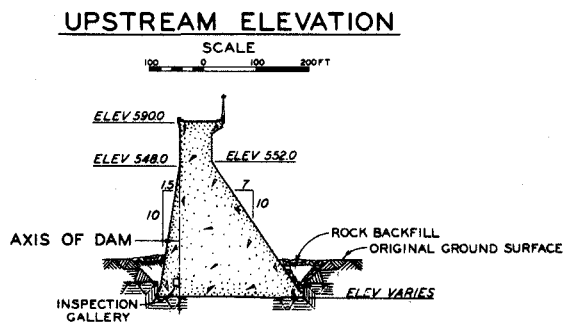
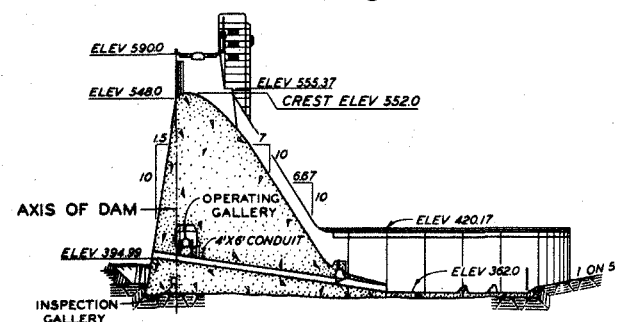
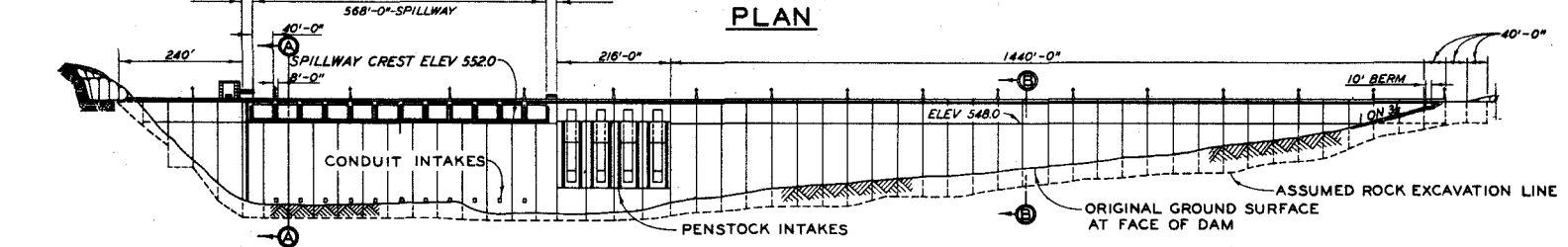
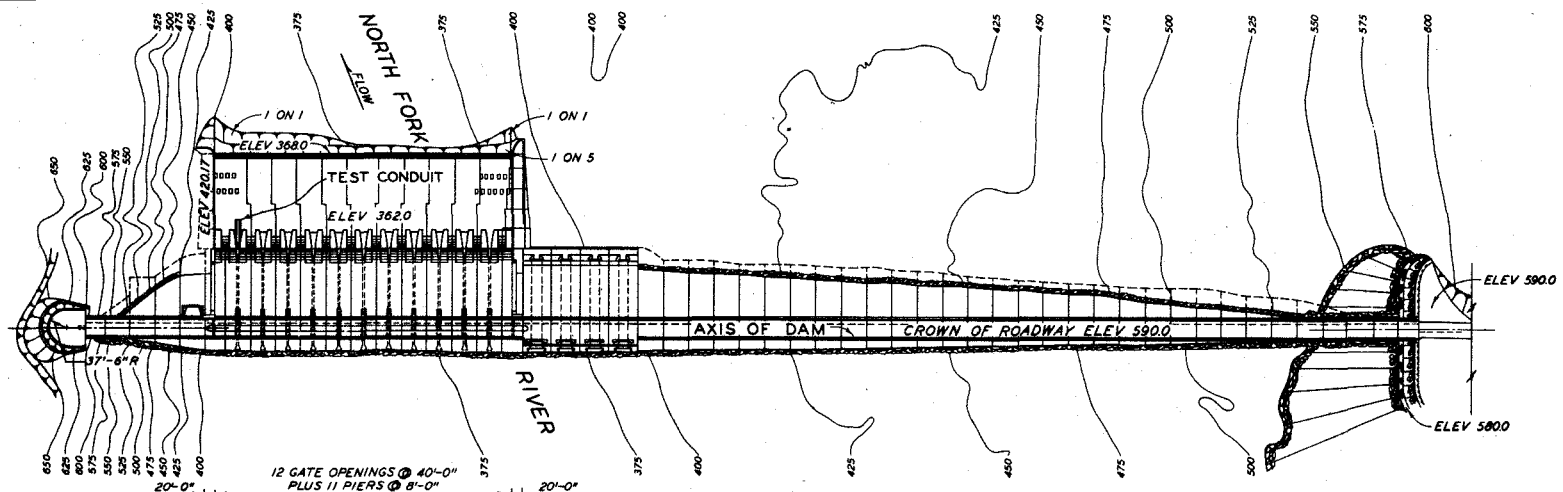

GENERAL DETAILS OF DAM

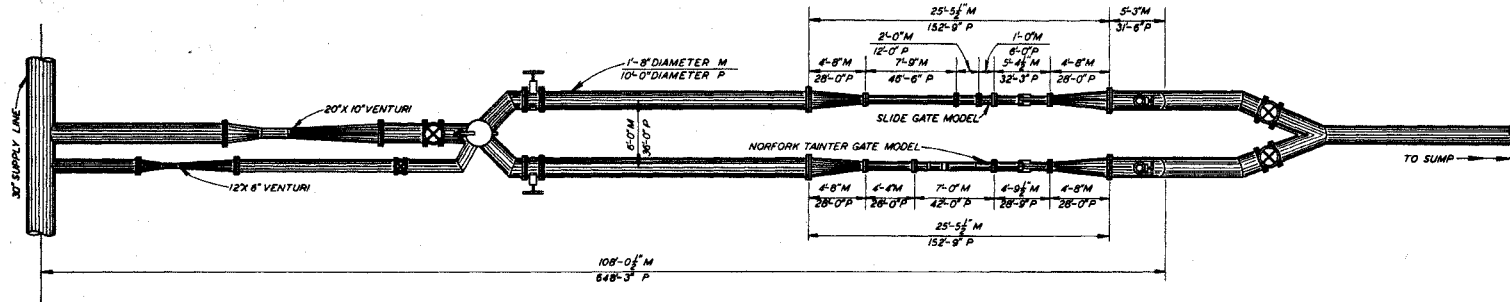

PLAN

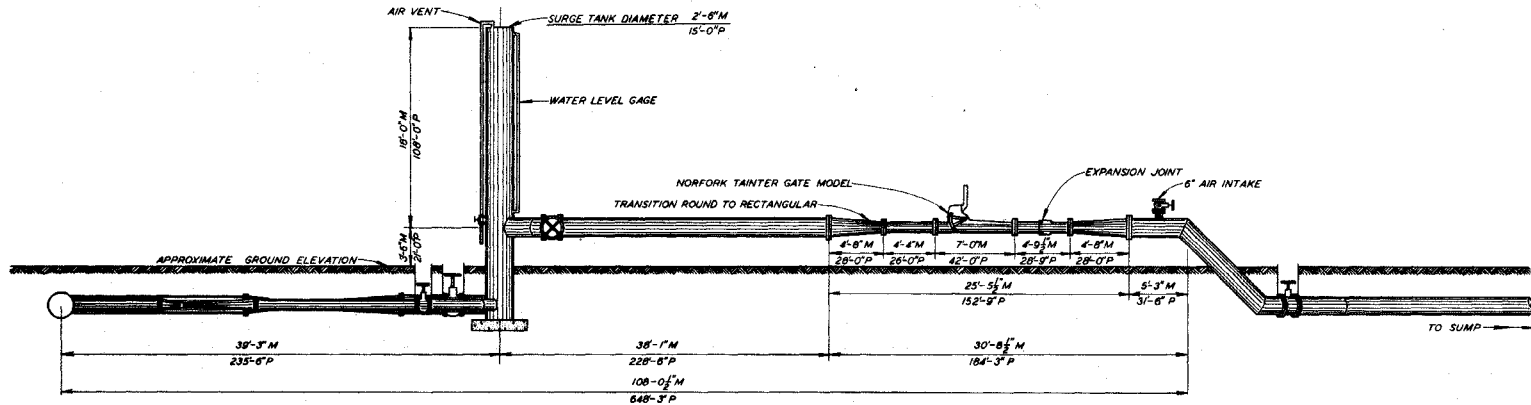

ELEVATION

GENERAL MODEL LAYOUT

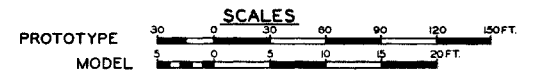

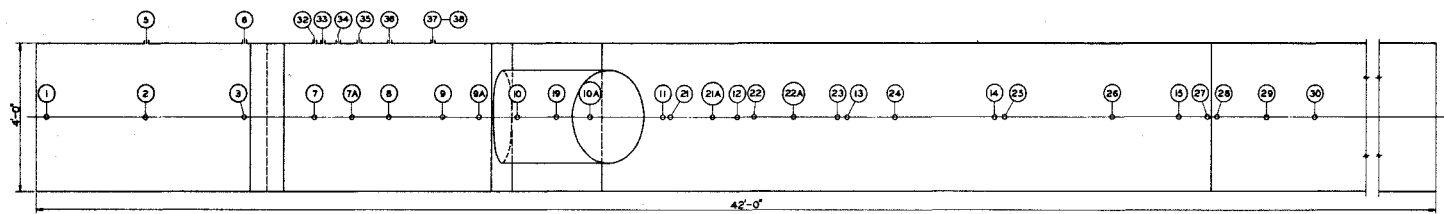

PLAN
(WITHOUT GATE)

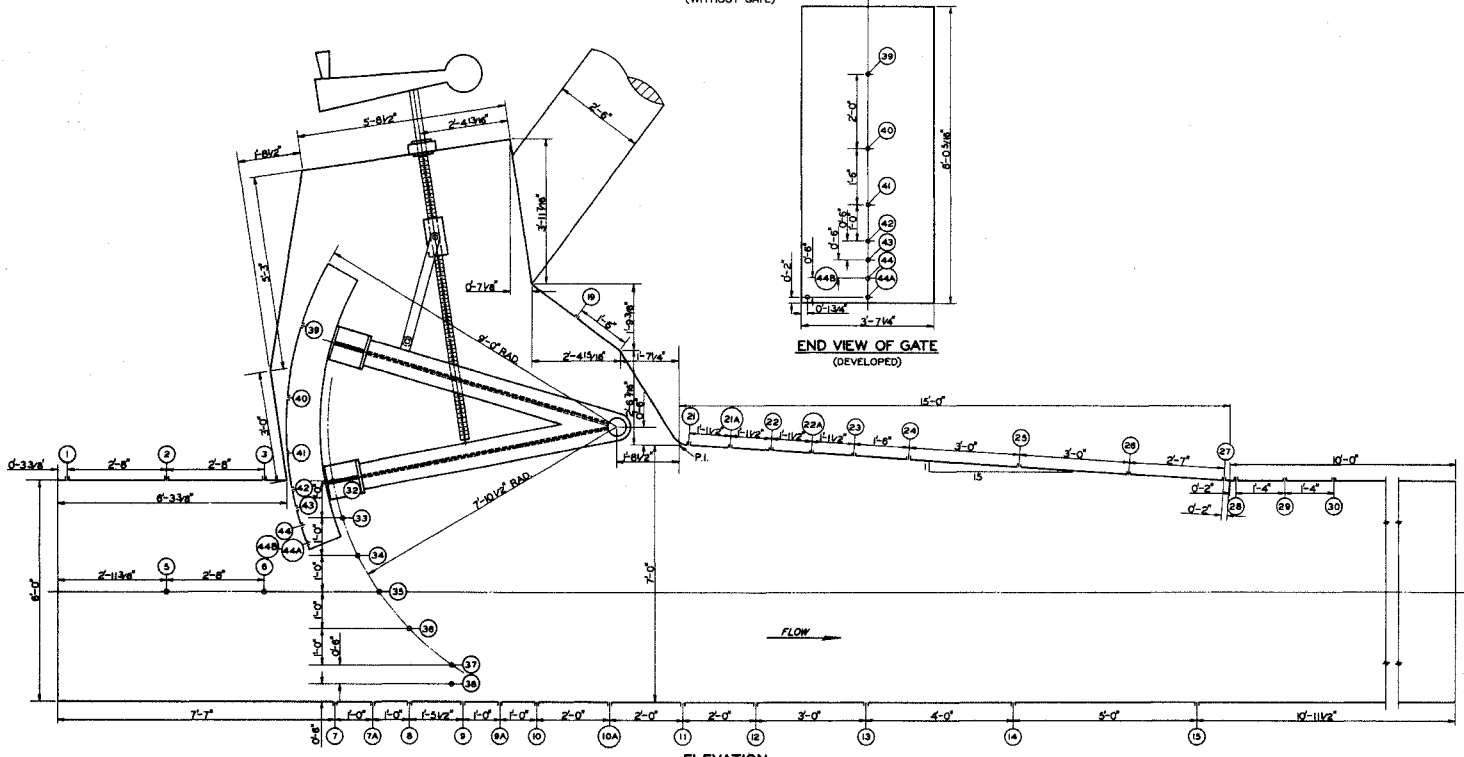

ELEVATION

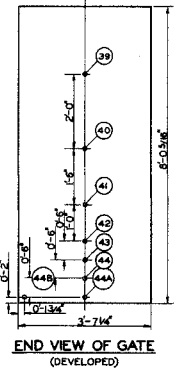

END VIEW OF GATE
(DEVELOPED)

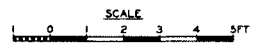

PIEZOMETER LOCATIONS
TAINTER GATE AND CONDUIT

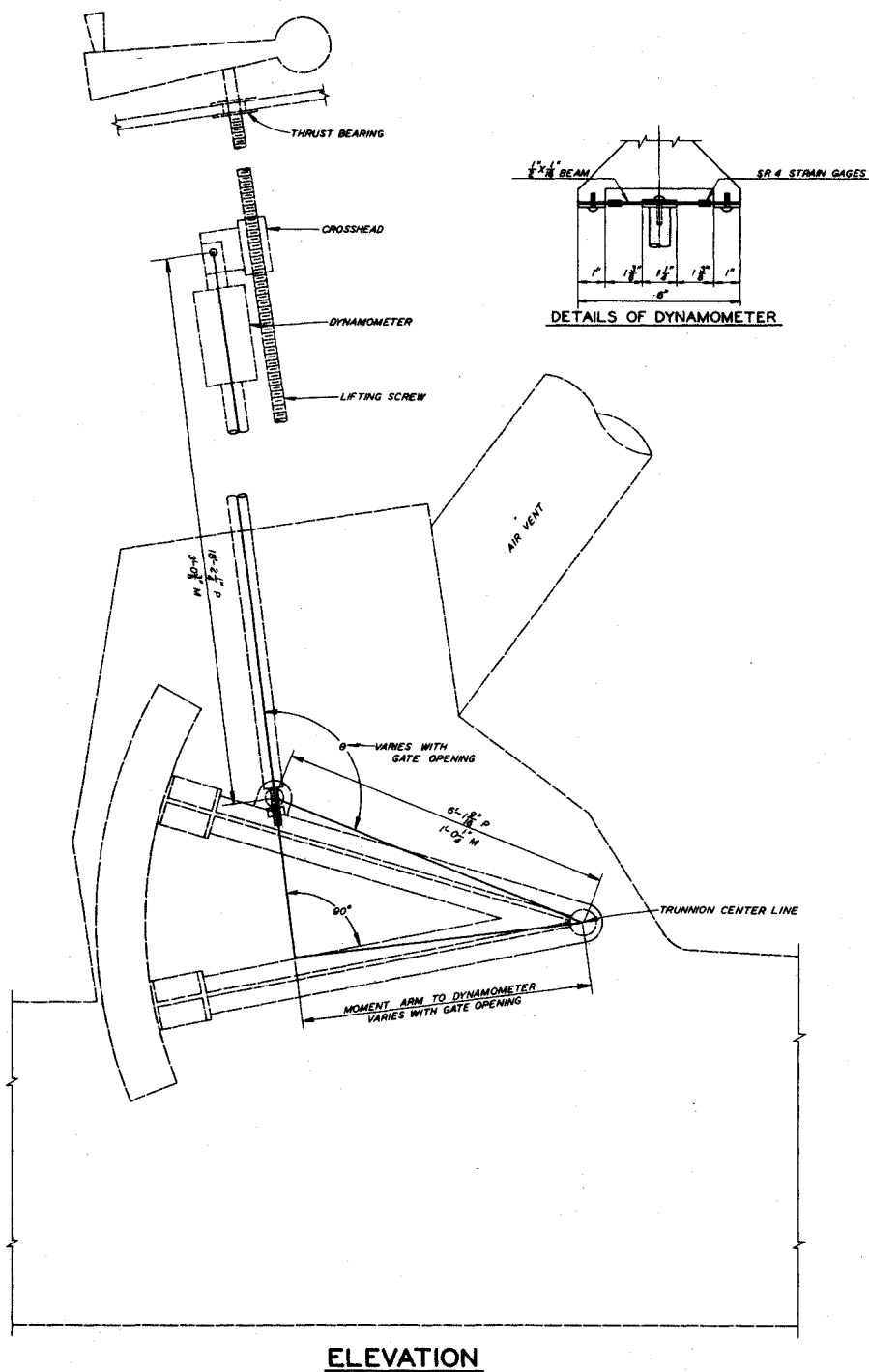

DETAILS AND LOCATION OF DYNAMOMETER

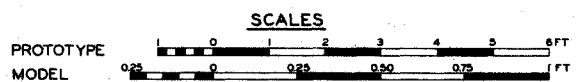

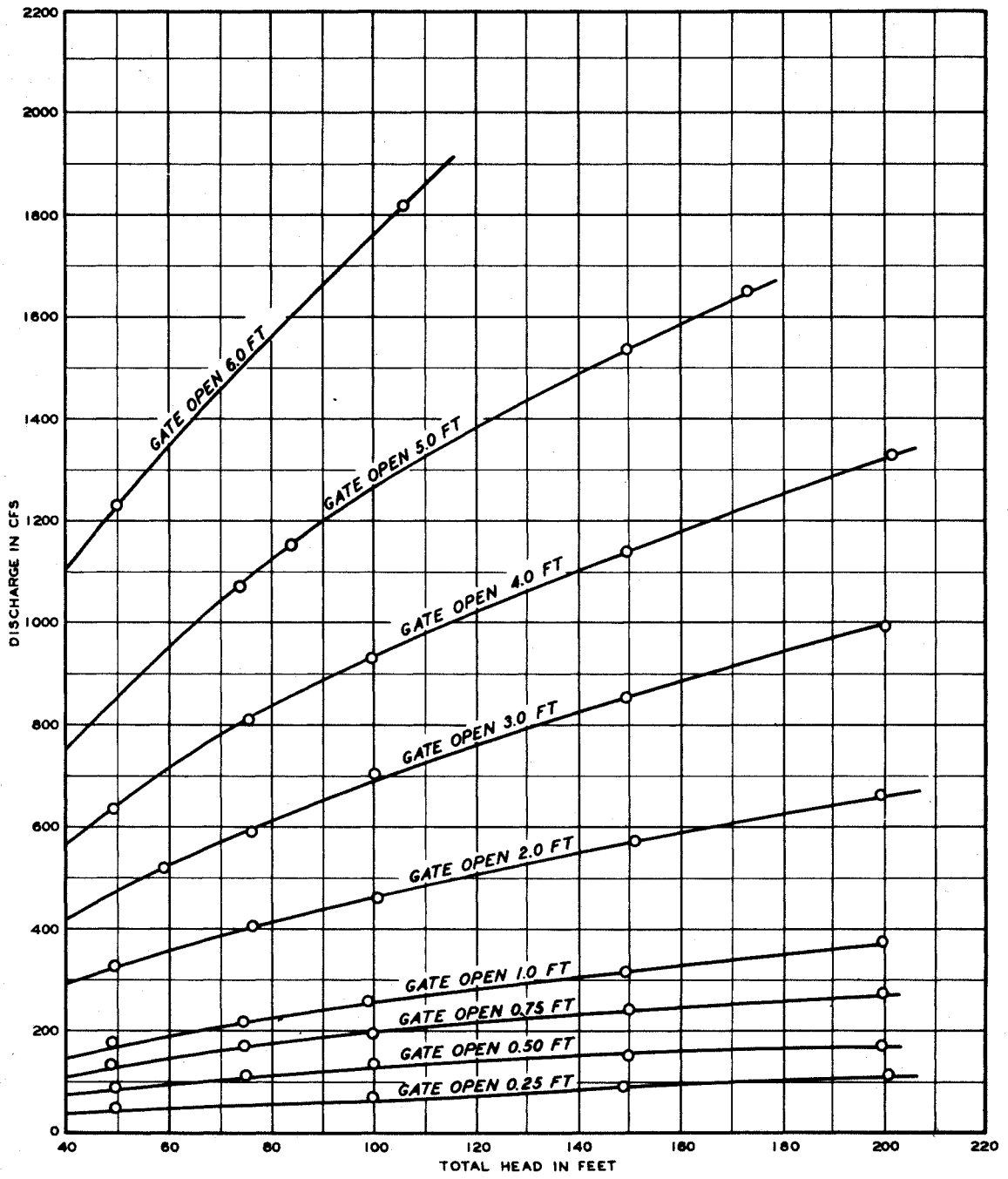

RATING CURVES

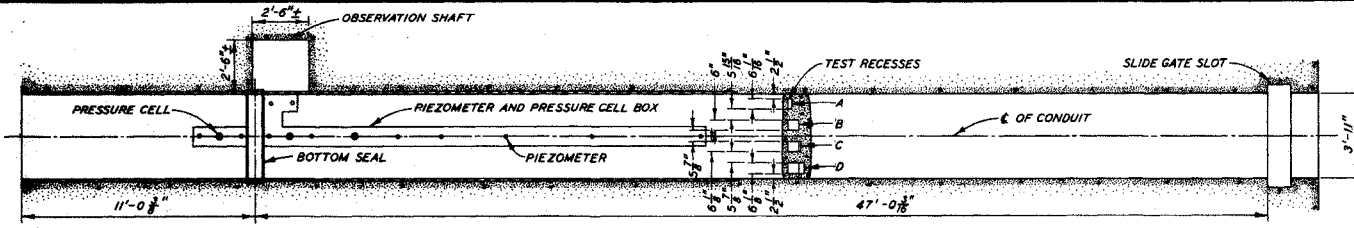

SECTION A-A

SCALE
1 0 1 2 3 4 5 FT

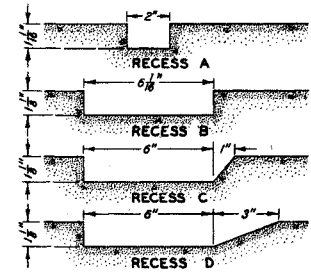

DETAILS OF TEST RECESSES

SCALE
1 0 1 2 3 4 5 IN.

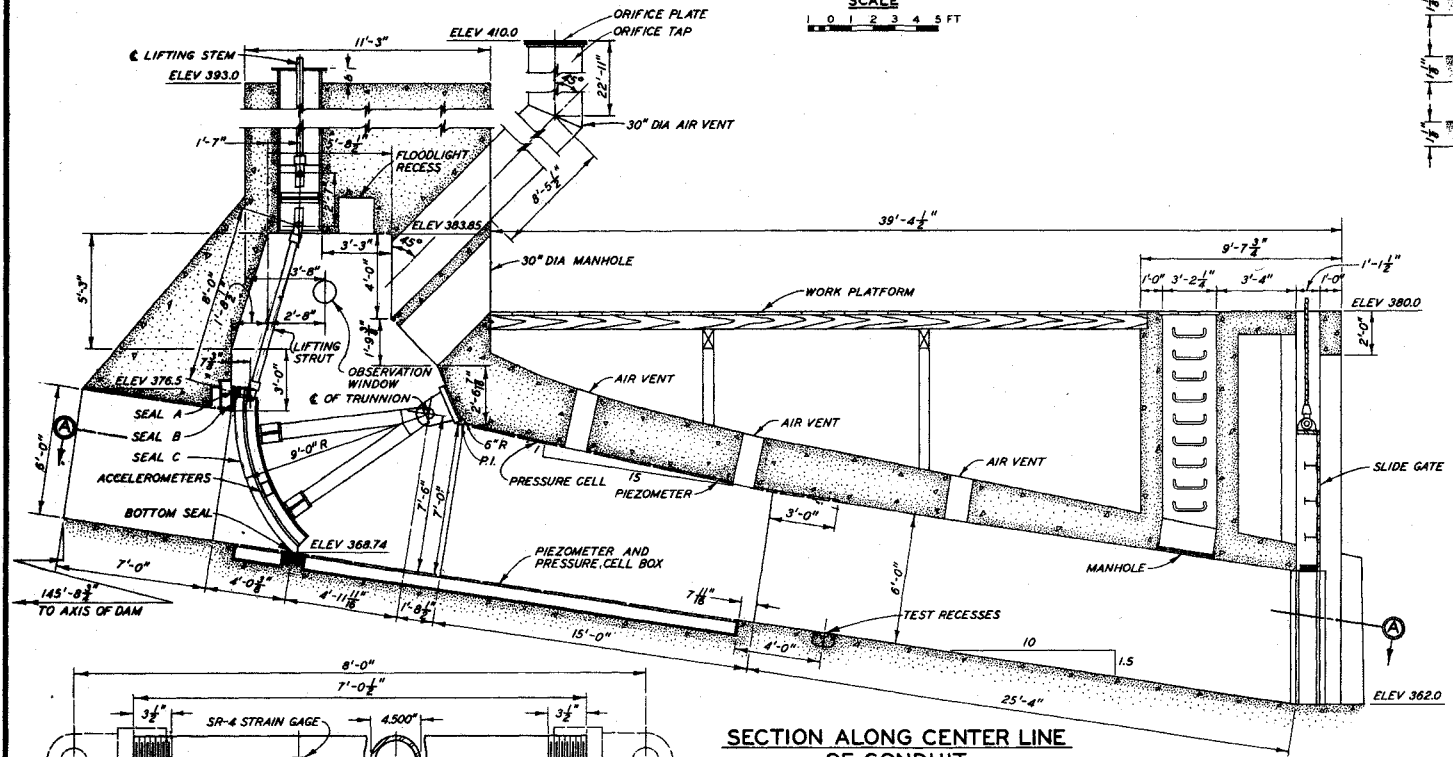

SECTION ALONG CENTER LINE OF CONDUIT

SCALE
1 0 1 2 3 4 5 FT

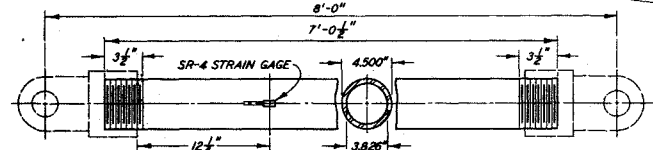

DETAILS OF LIFTING STRUT

SCALE
3 0 3 6 9 12 IN.

DETAILS OF TEST CONDUIT

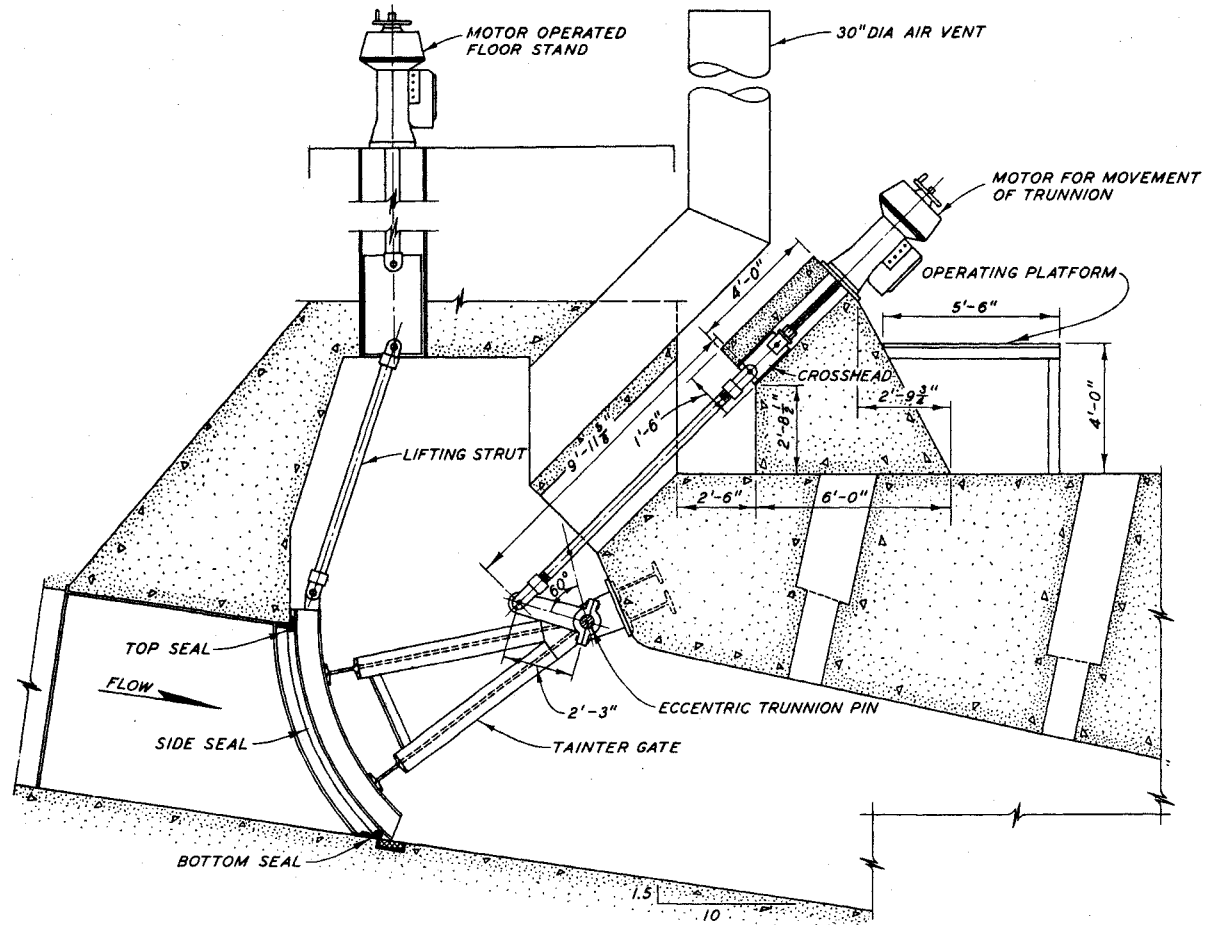

DETAILS OF ECCENTRIC TRUNNION-TYPE GATE

SCALE IN FEET



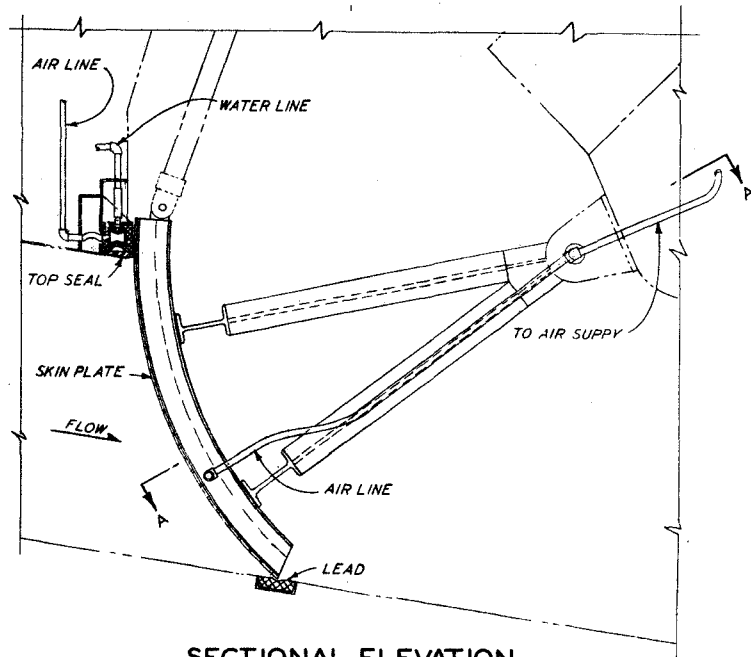

SECTIONAL ELEVATION

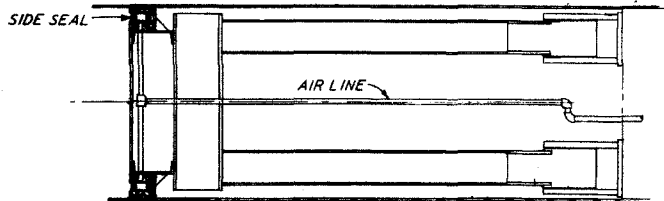

SECTION A-A

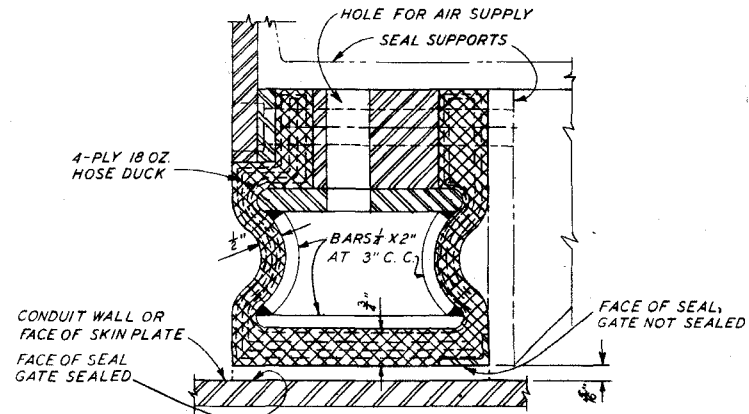
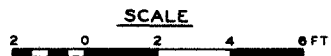

TYPICAL SECTION THROUGH SEAL

SCALE



**DETAILS OF
PNEUMATIC-TYPE GATE SEAL
FIXED-TRUNNION-TYPE GATE**

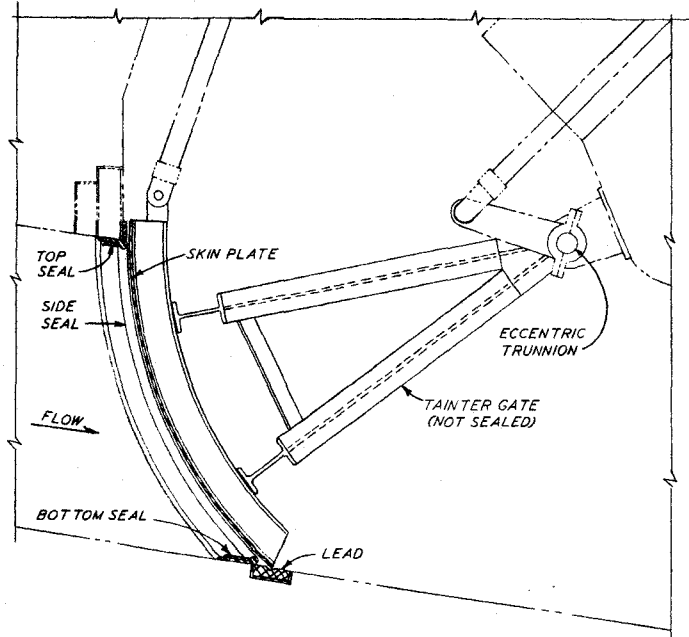

SECTIONAL ELEVATION

SCALE

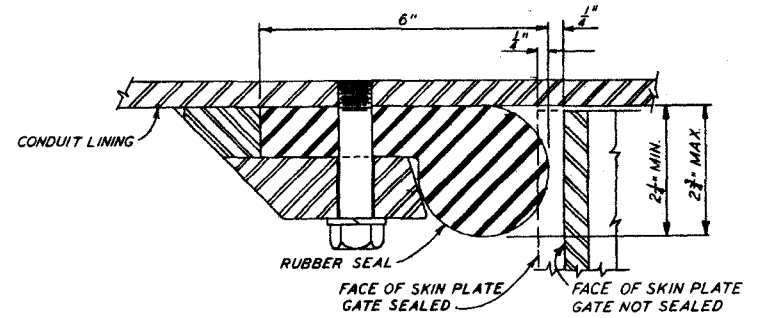
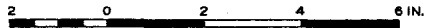

TYPE D

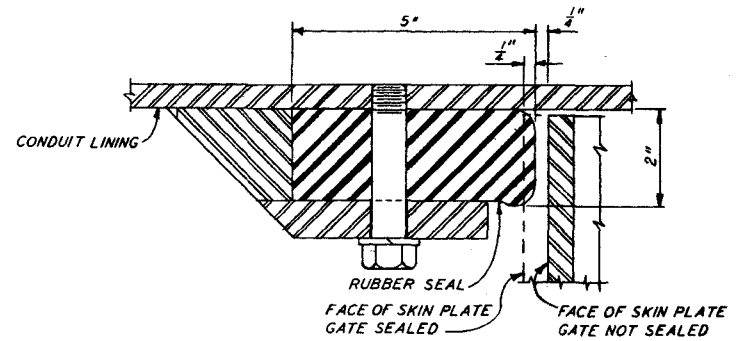

TYPE E

TYPICAL SECTIONS THROUGH SEALS

SCALE



**DETAILS OF GATE SEALS
ECCENTRIC TRUNNION-TYPE GATE**

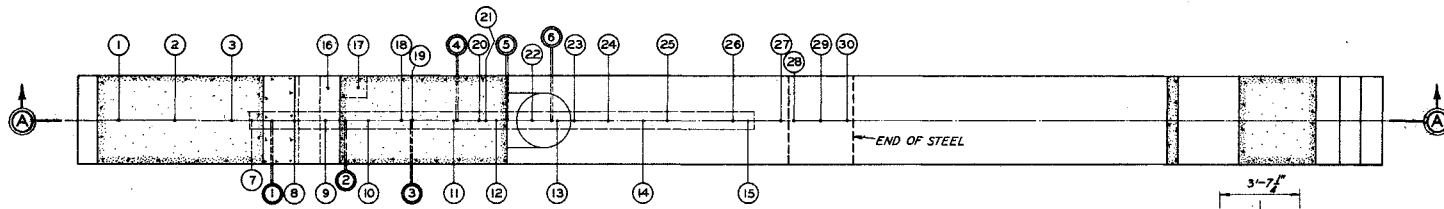

PLAN
(WITHOUT GATE)

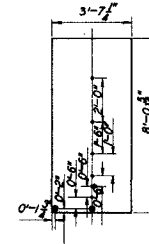

END VIEW OF GATE
(DEVELOPED)

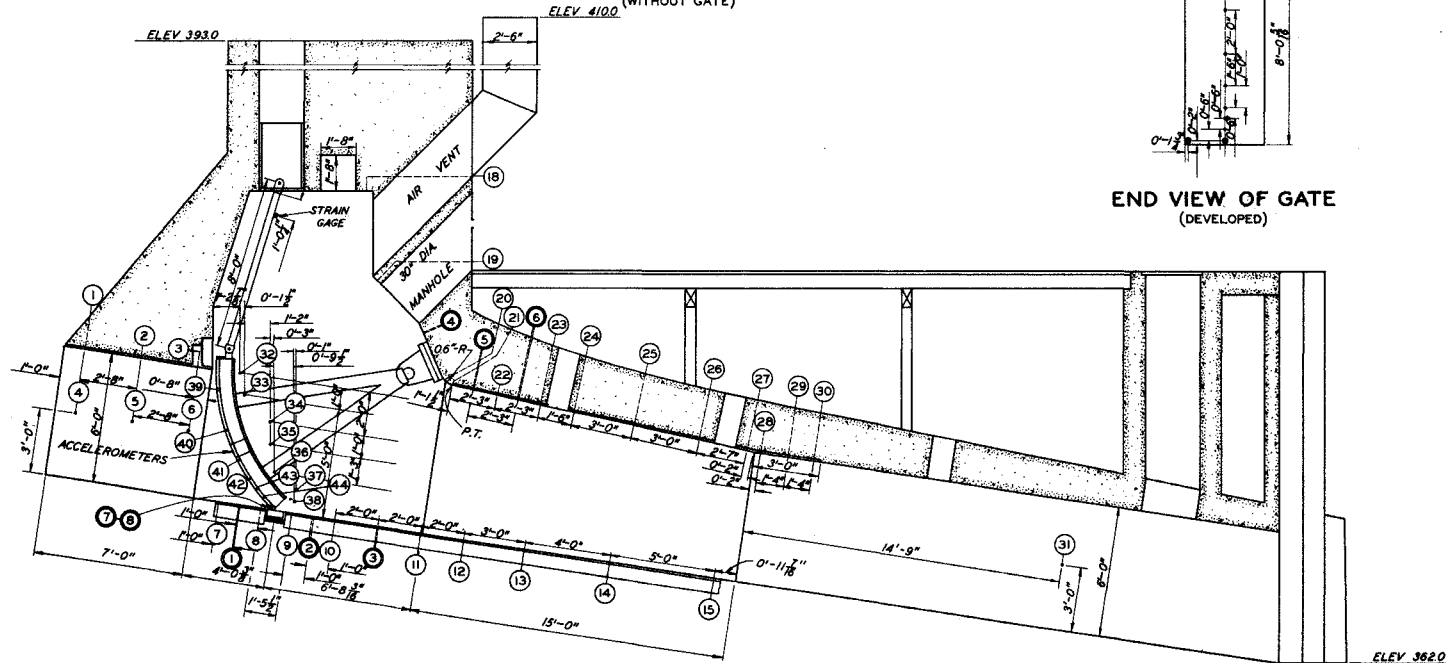

SECTION A-A

NOTE: (4) DENOTES PIEZOMETER LOCATION.
(3) DENOTES PRESSURE CELL LOCATION.

LOCATIONS OF TESTING
EQUIPMENT

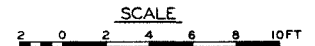

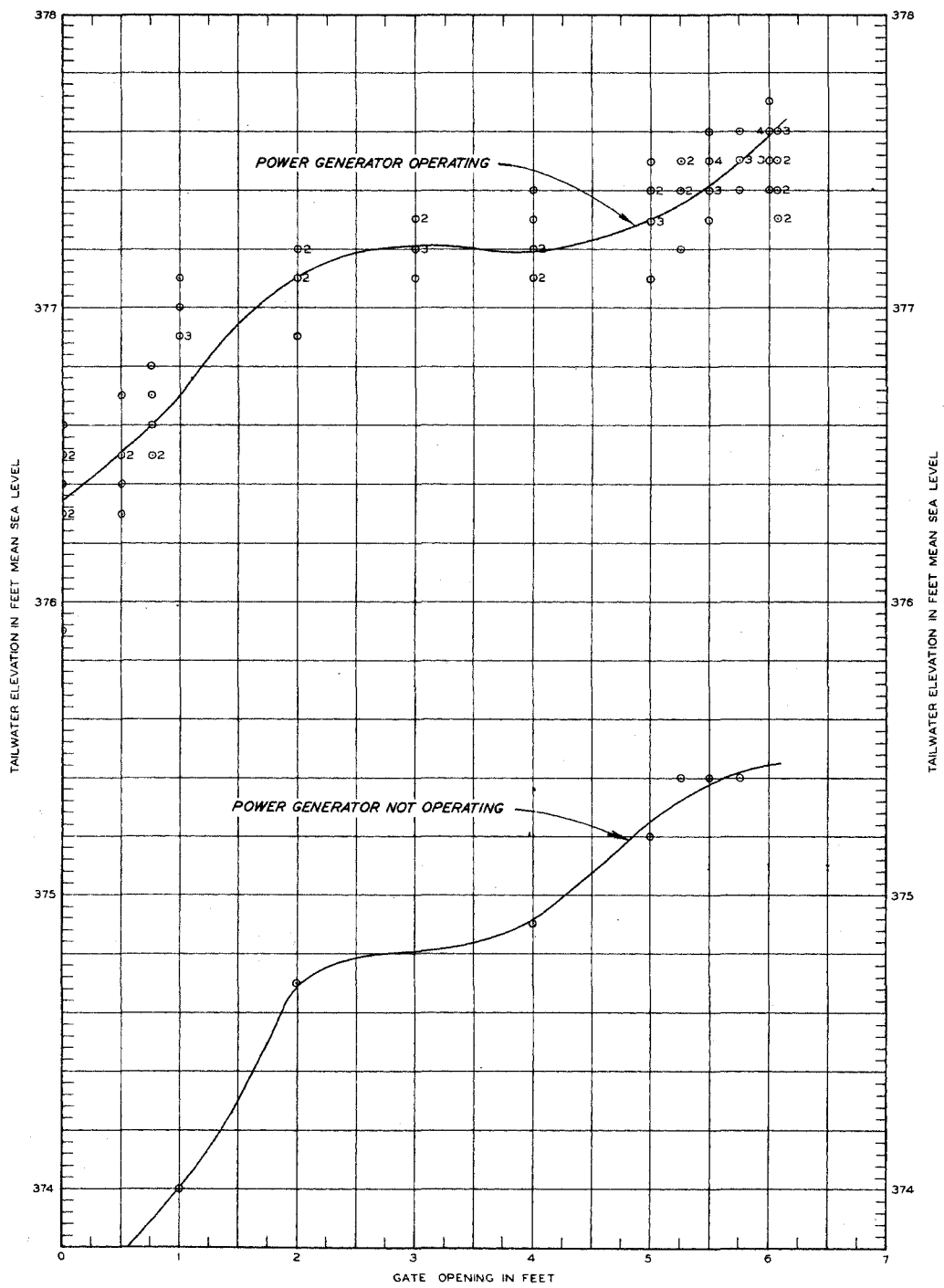

TAILWATER CURVES

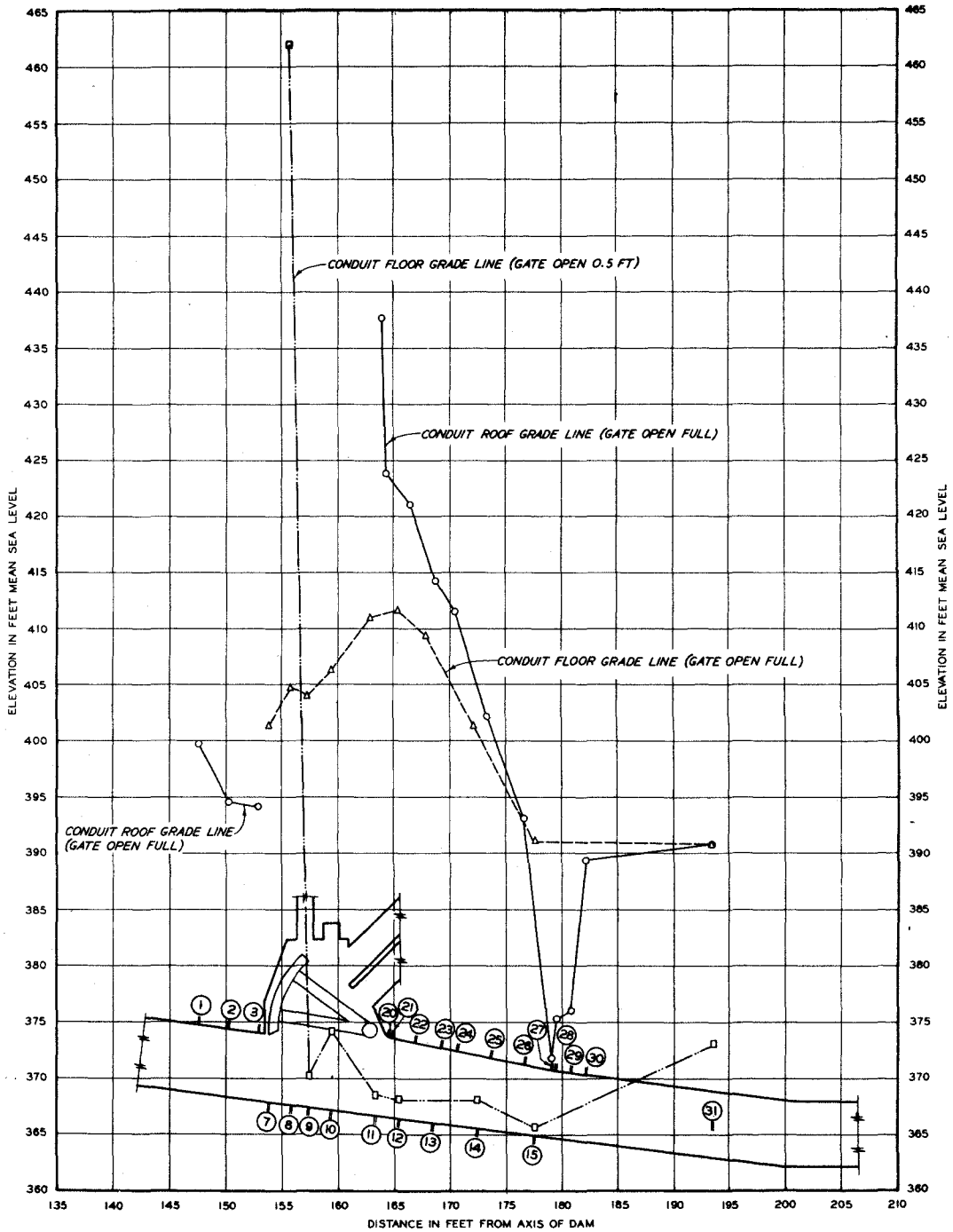

PRESSURE GRADE LINES

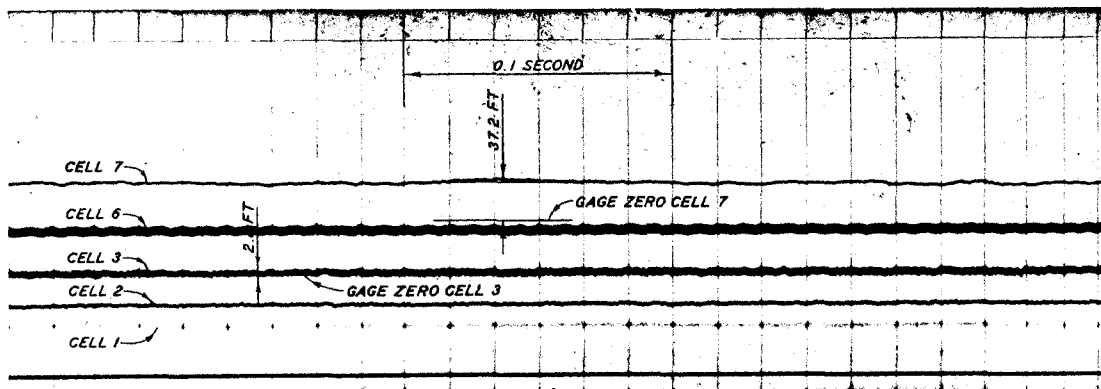

GATE OPEN 3.0 FEET

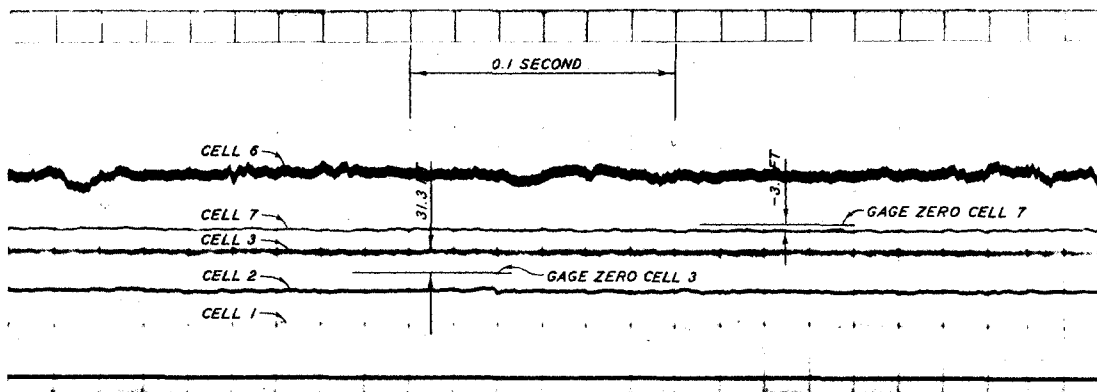

GATE OPEN FULL

NOTE: PRESSURES ARE IN FEET OF WATER.
AIR VENT OPEN FULL.

TYPICAL OSCILLOGRAPH RECORD
PRESSURE DATA

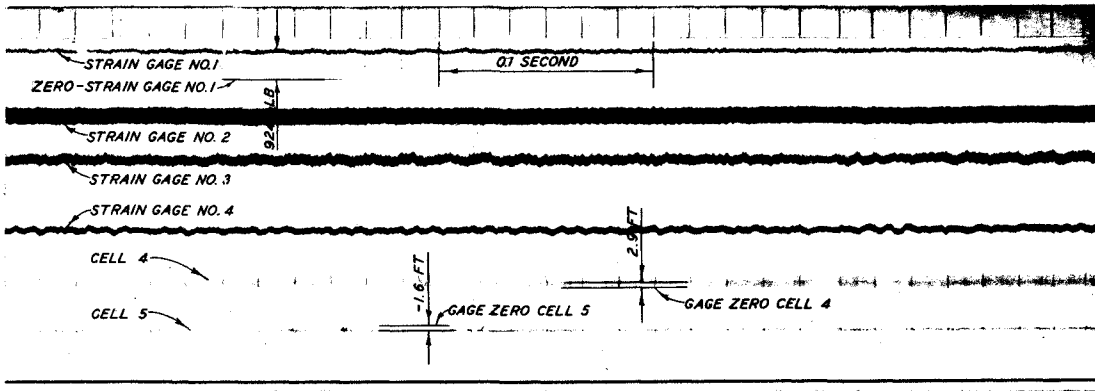

GATE OPEN 3.0 FEET

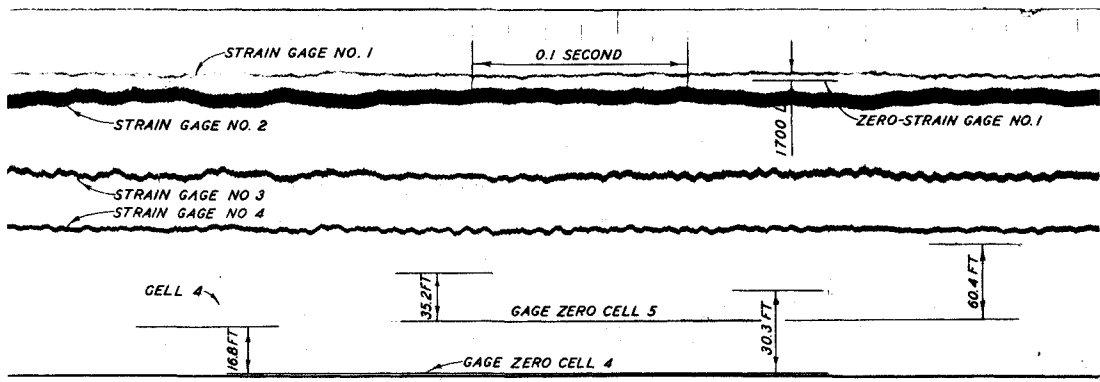

GATE OPEN FULL

NOTE: PRESSURES ARE IN FEET OF WATER.
 STRAIN IS IN POUNDS INCLUDING
 WEIGHT OF GATE.
 AIR VENT OPEN FULL.

TYPICAL OSCILLOGRAPH RECORD
 PRESSURE AND STRAIN DATA

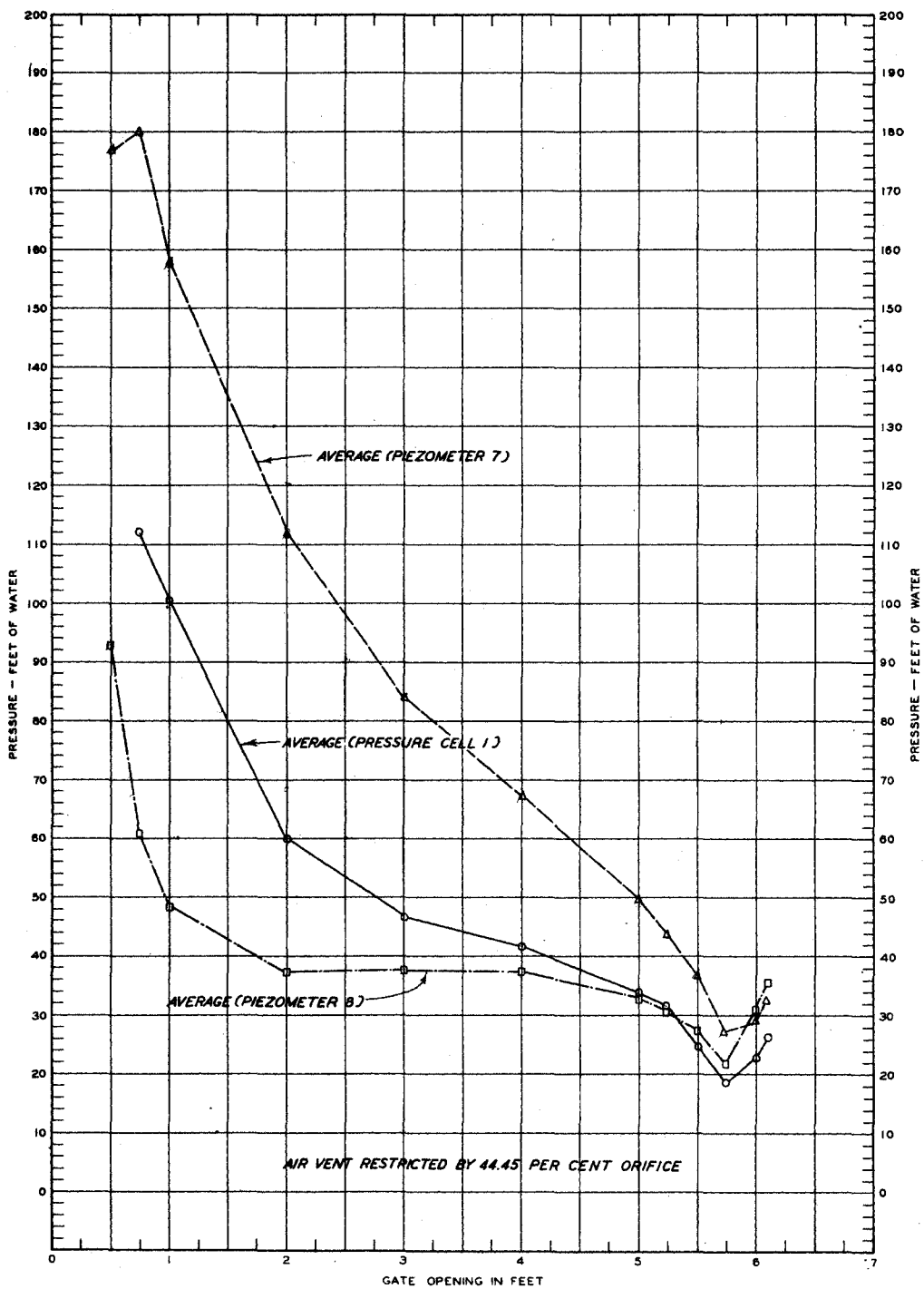

PRESSURE COMPARISONS
 PRESSURE CELL 1
 PIEZOMETERS 7 AND 8

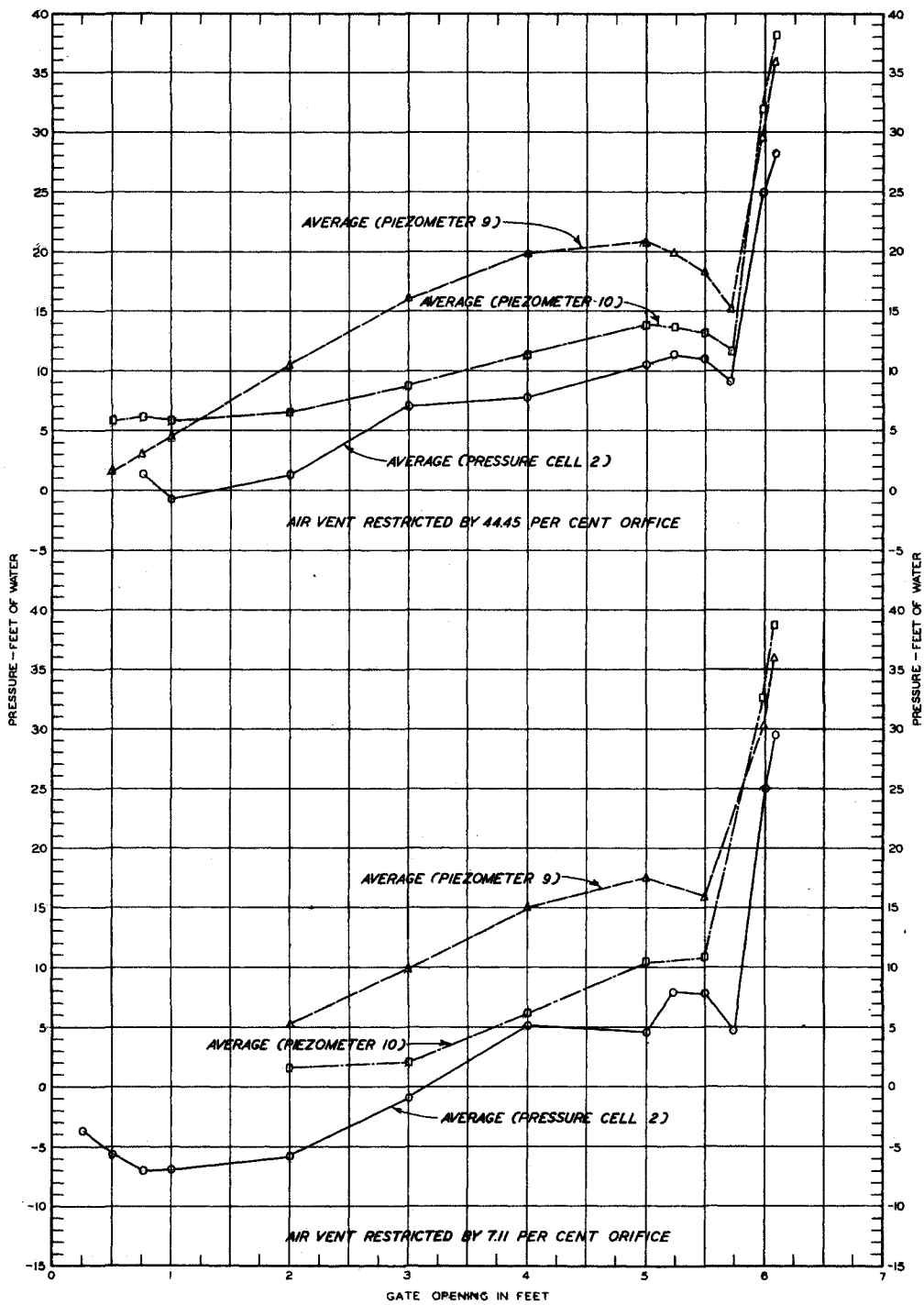

PRESSURE COMPARISONS
PRESSURE CELL 2
PIEZOMETERS 9 AND 10

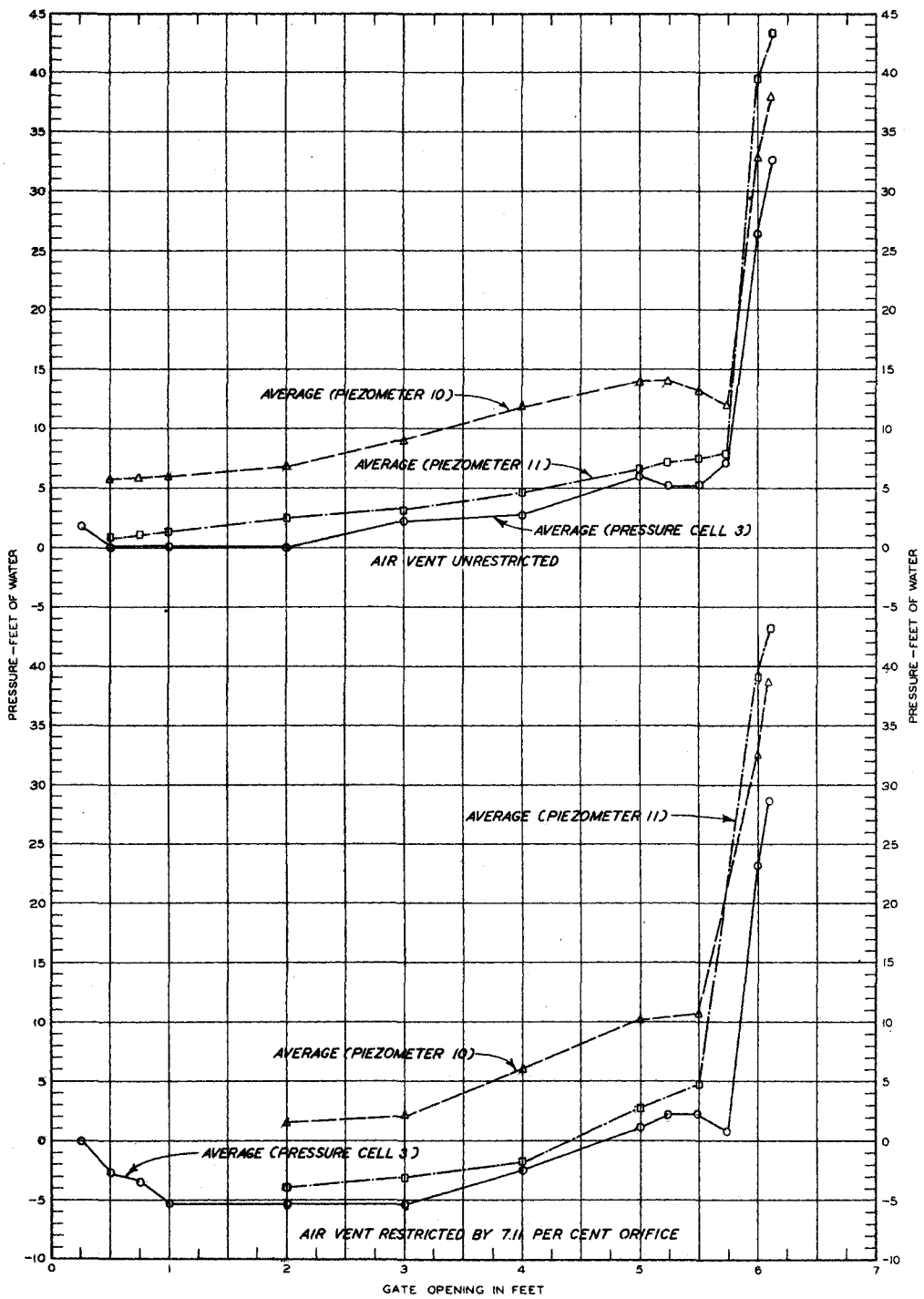

PRESSURE COMPARISONS
 PRESSURE CELL 3
 PIEZOMETERS 10 AND 11

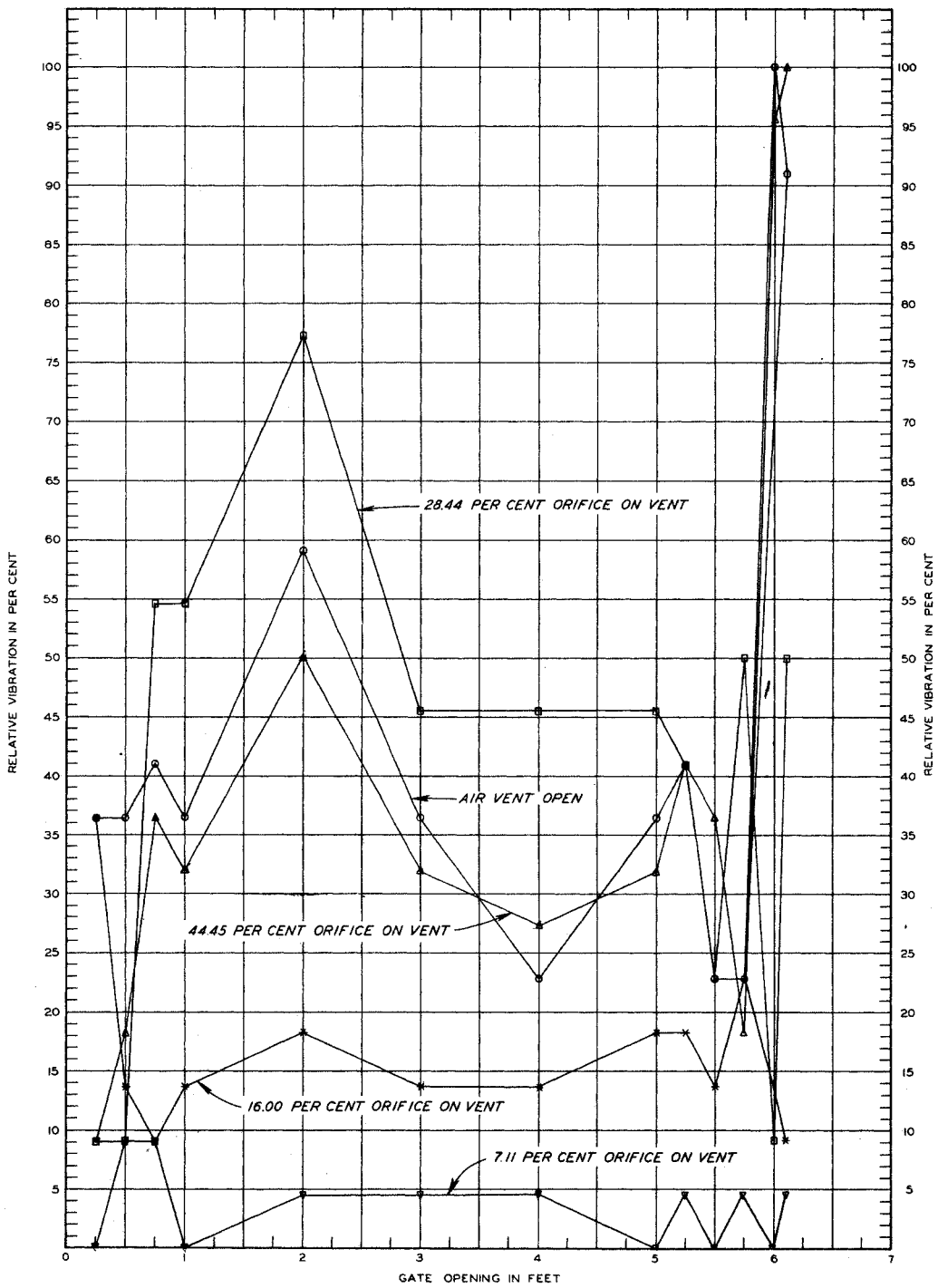

NOTE: RELATIVE VIBRATION IS IN PER CENT OF MAXIMUM
 VIBRATION IN A TRANSVERSE DIRECTION
 ACCELEROMETER LOCATION SHOWN ON PLATE 2

VIBRATION AMPLITUDE TRANSVERSE DIRECTION

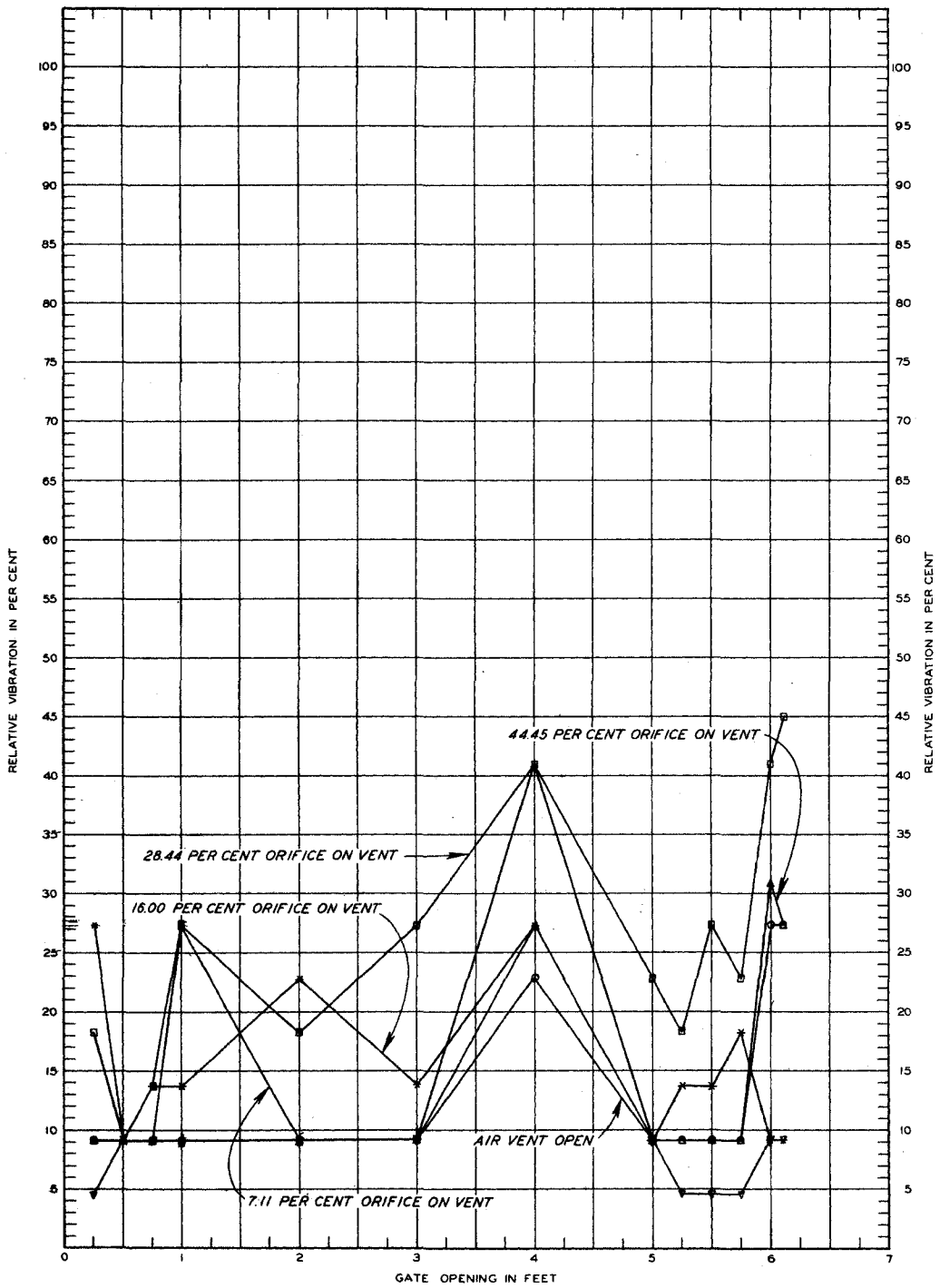

NOTE: RELATIVE VIBRATION IS IN PER CENT OF MAXIMUM VIBRATION IN A TRANSVERSE DIRECTION
ACCELEROMETER LOCATION SHOWN ON PLATE 2

VIBRATION AMPLITUDE LONGITUDINAL DIRECTION

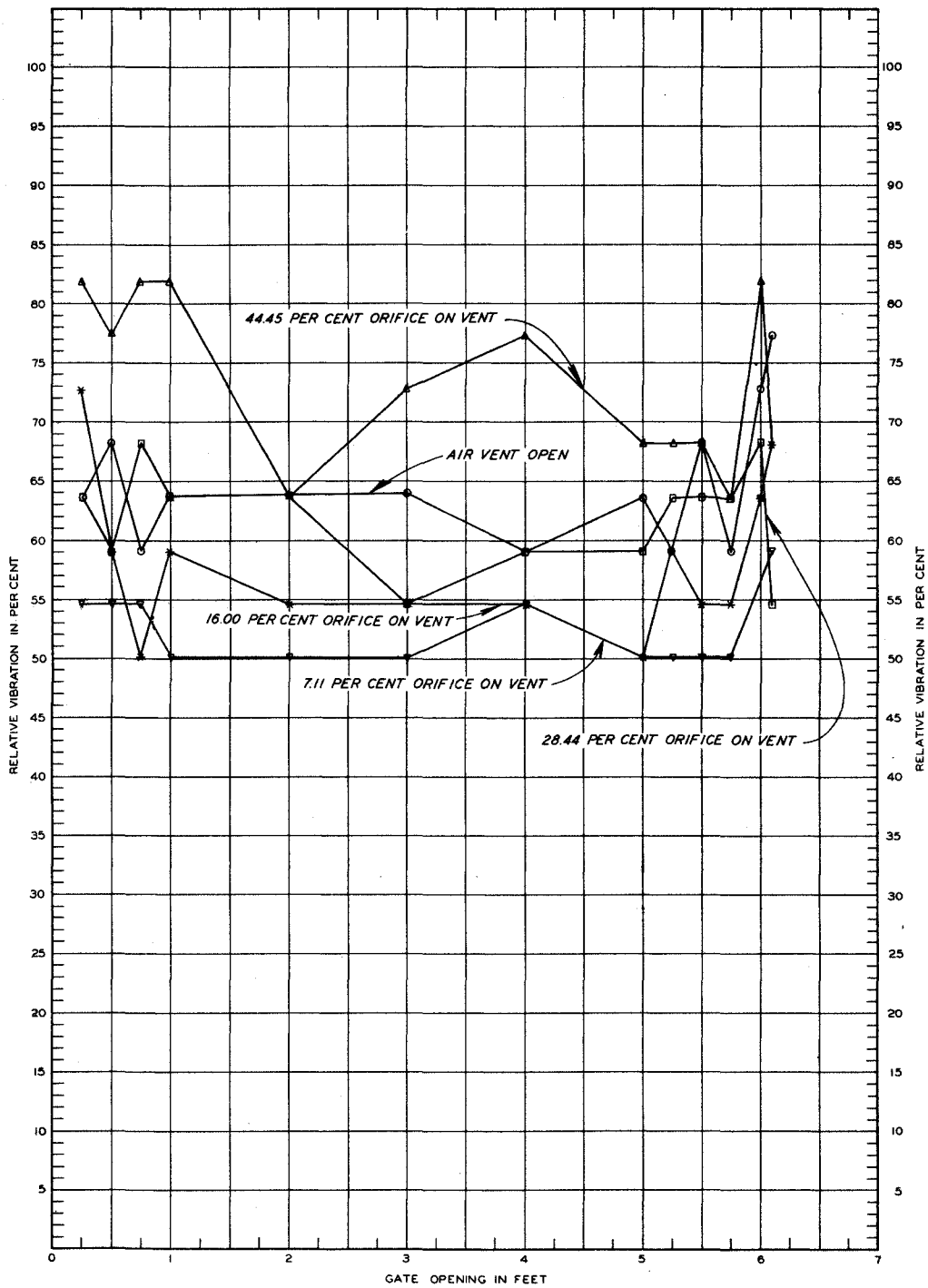

NOTE: RELATIVE VIBRATION IS IN PER CENT OF MAXIMUM VIBRATION IN A TRANSVERSE DIRECTION. ACCELEROMETER LOCATION SHOWN ON PLATE 2.

VIBRATION AMPLITUDE VERTICAL DIRECTION

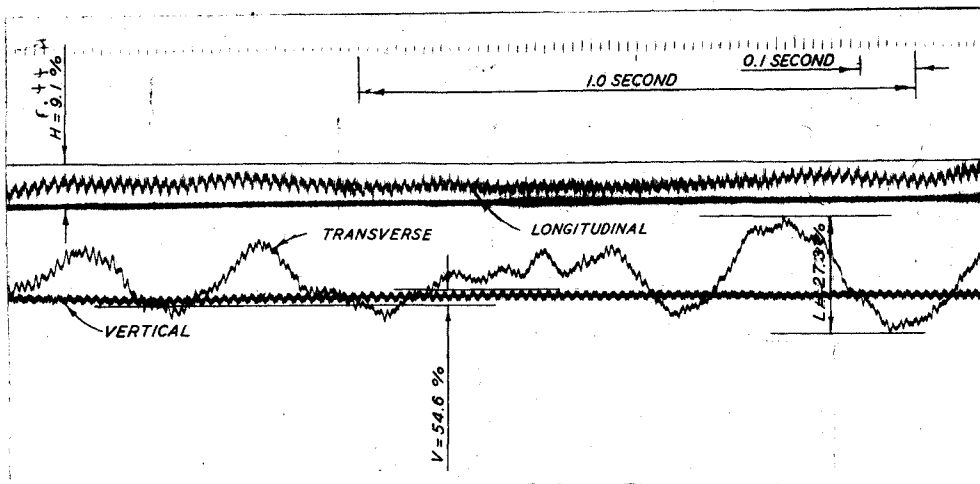

GATE OPEN 3.0 FEET

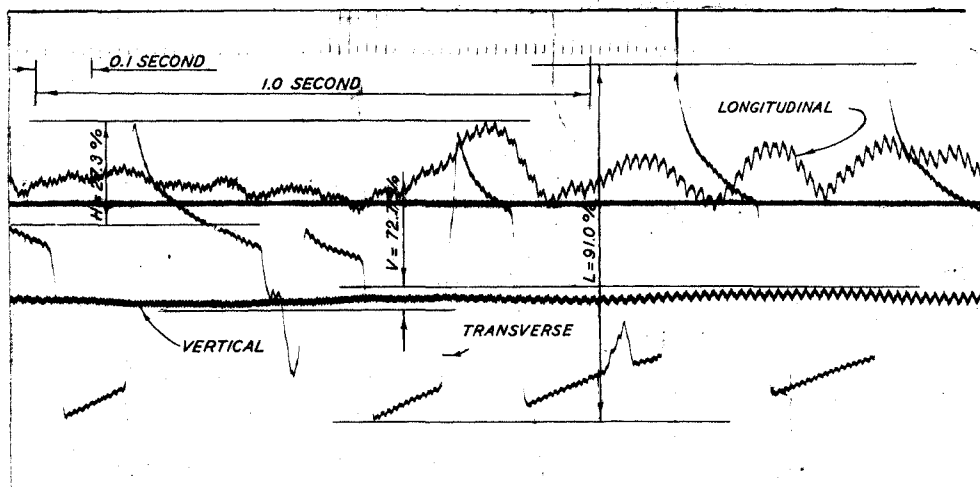

GATE OPEN FULL

NOTE: RELATIVE VIBRATION IS IN
 PERCENT OF MAXIMUM VIBRATION
 IN A TRANSVERSE DIRECTION
 AIR VENT OPEN FULL.

TYPICAL OSCILLOGRAPH RECORD
 VIBRATION AMPLITUDE

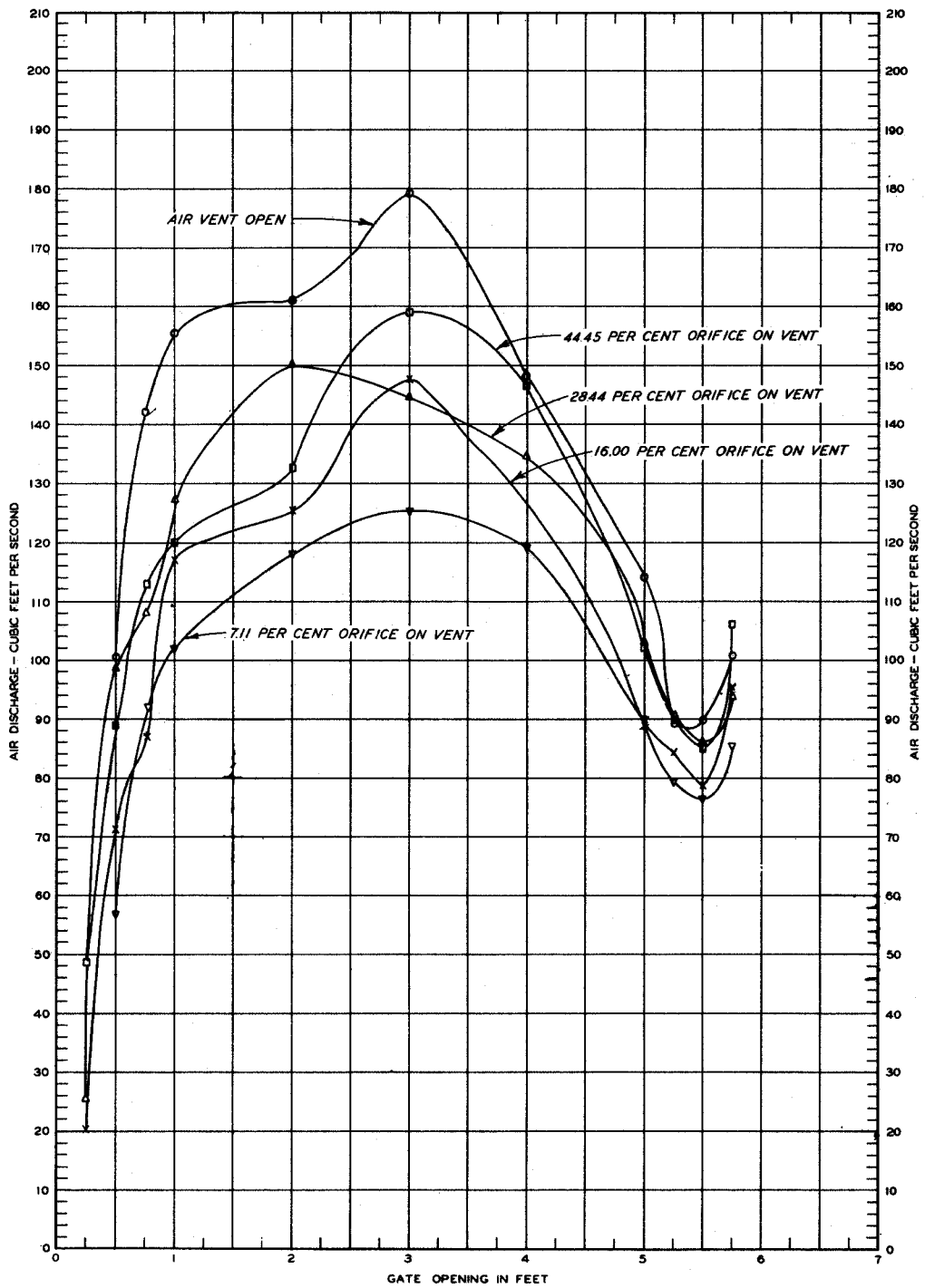

NOTE: ORIGINAL AIR VENT 30 INCHES
IN DIAMETER.

AIR FLOW

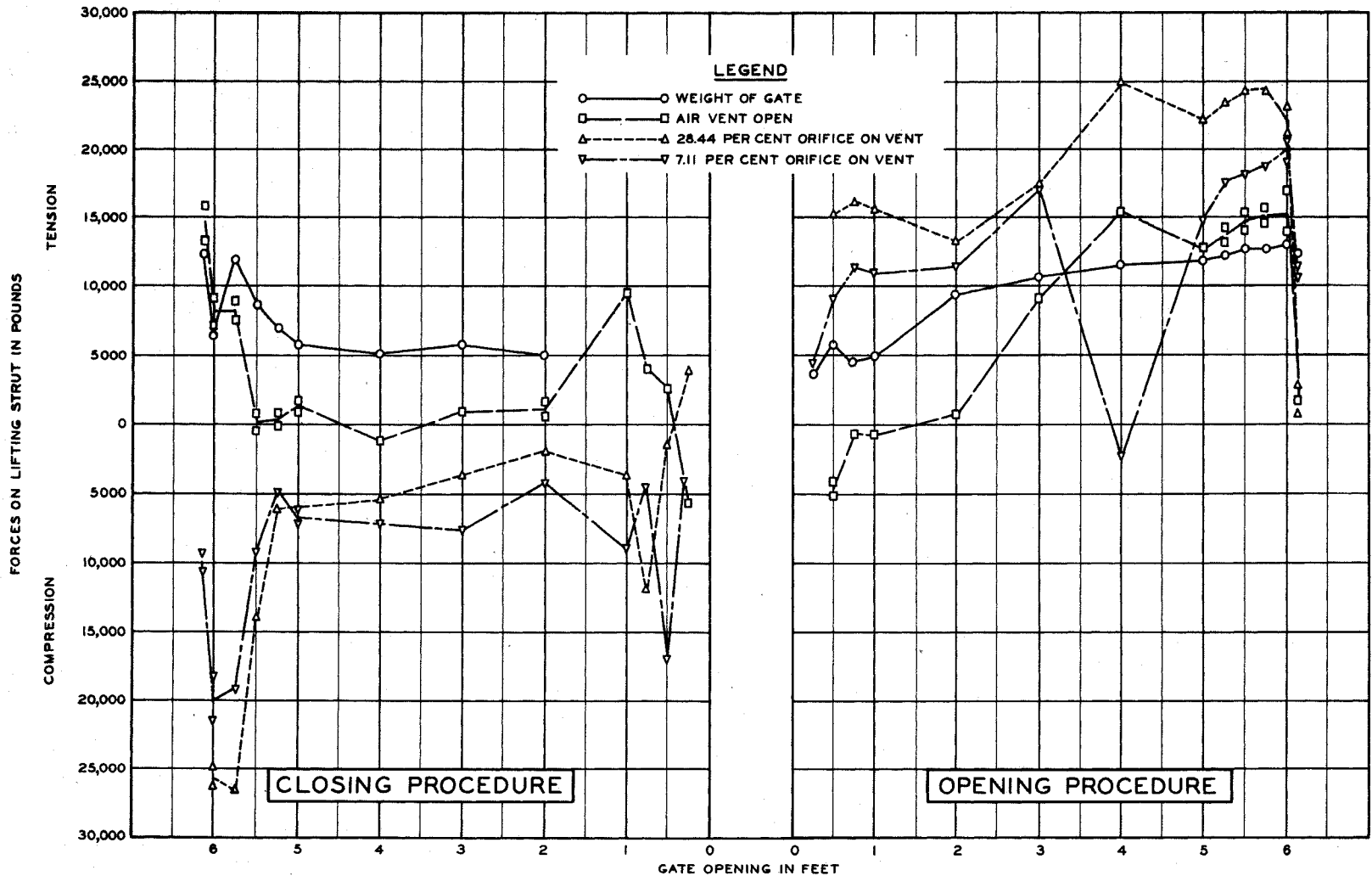

FORCES ON LIFTING STRUT
FIXED TRUNNION-TYPE GATE

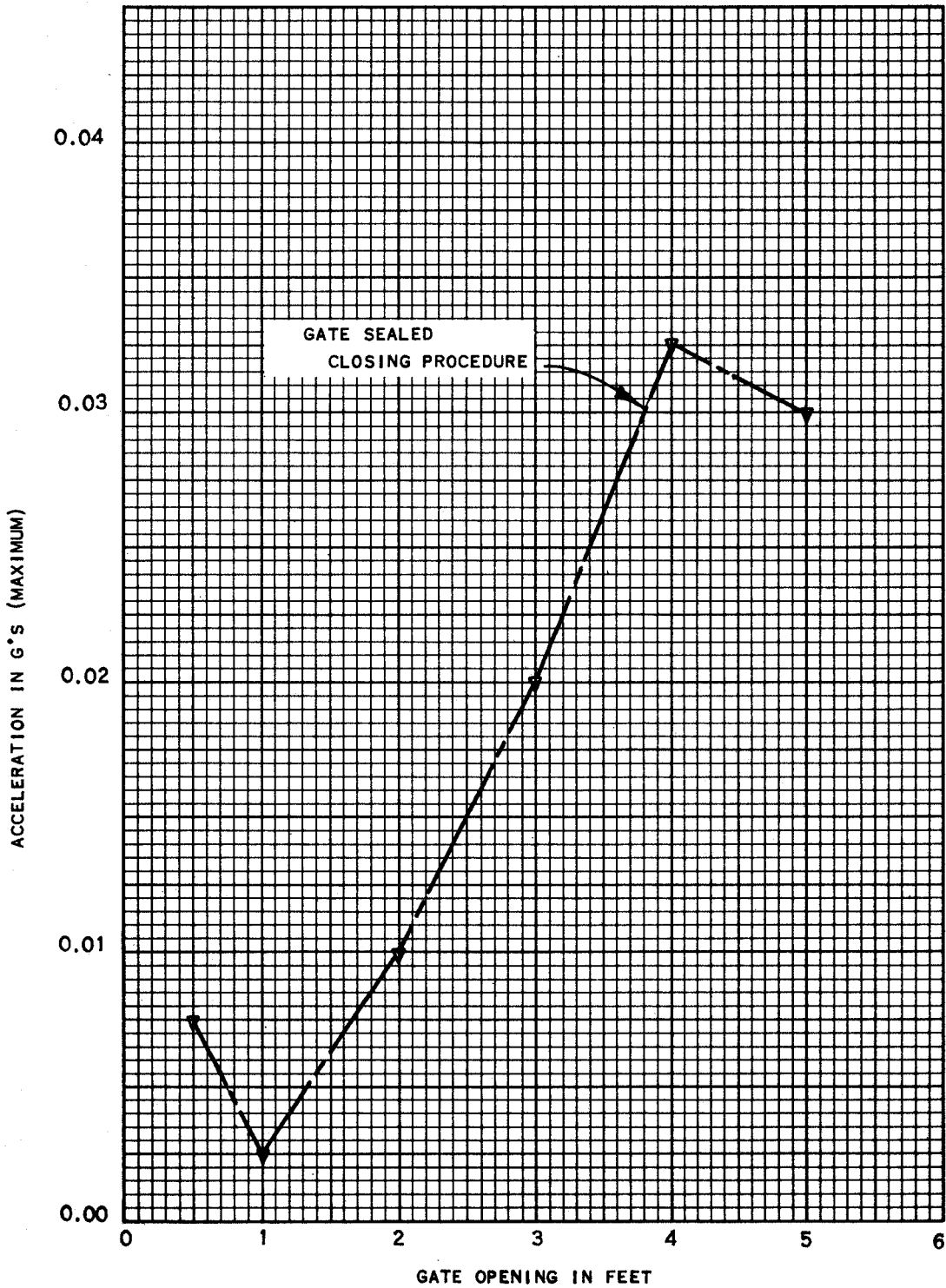

VIBRATION CHARACTERISTICS
TRANSVERSE DIRECTION
ECCENTRIC TRUNNION-TYPE GATE

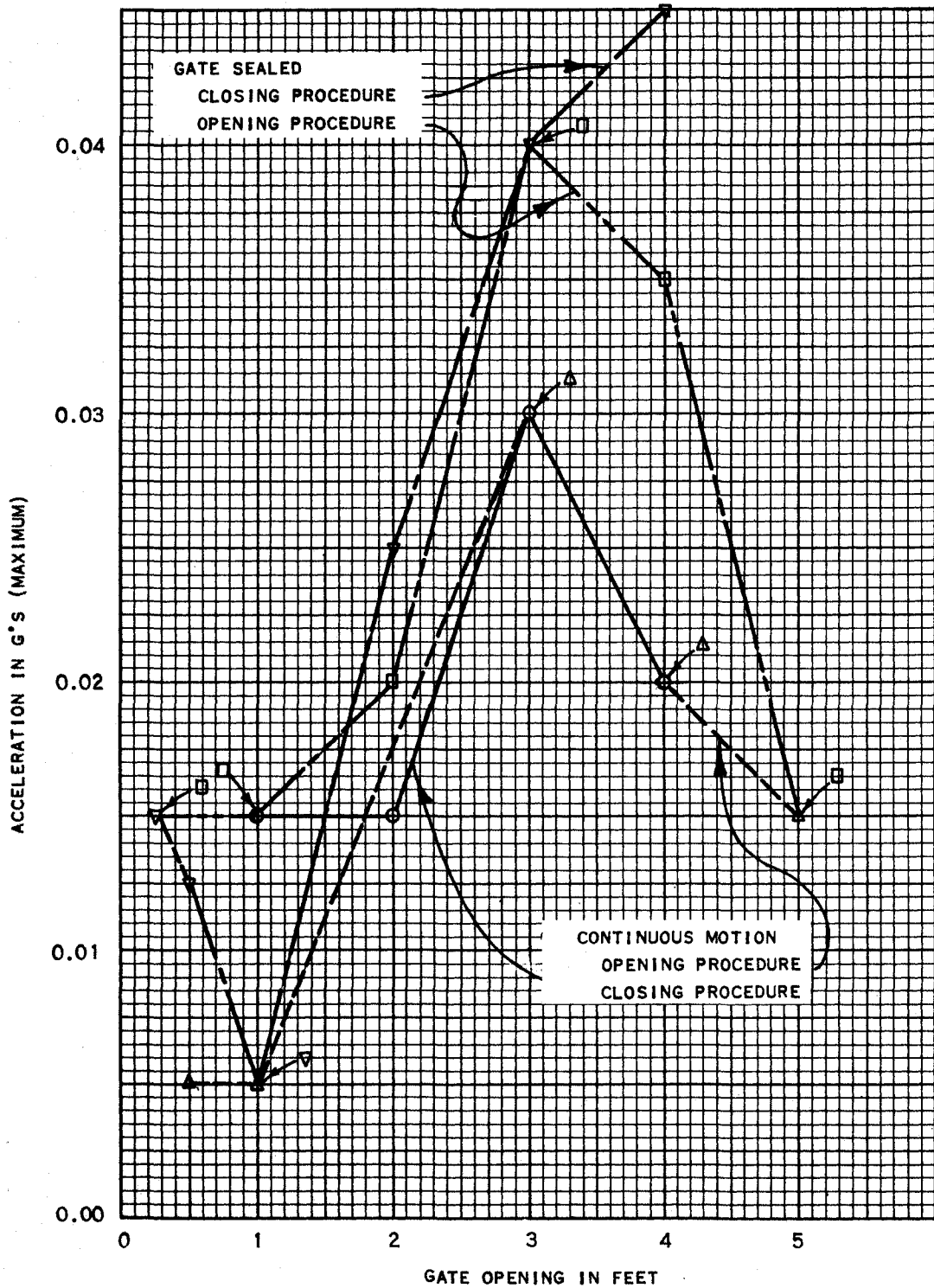

VIBRATION CHARACTERISTICS
 LONGITUDINAL DIRECTION
 ECCENTRIC TRUNNION-TYPE GATE

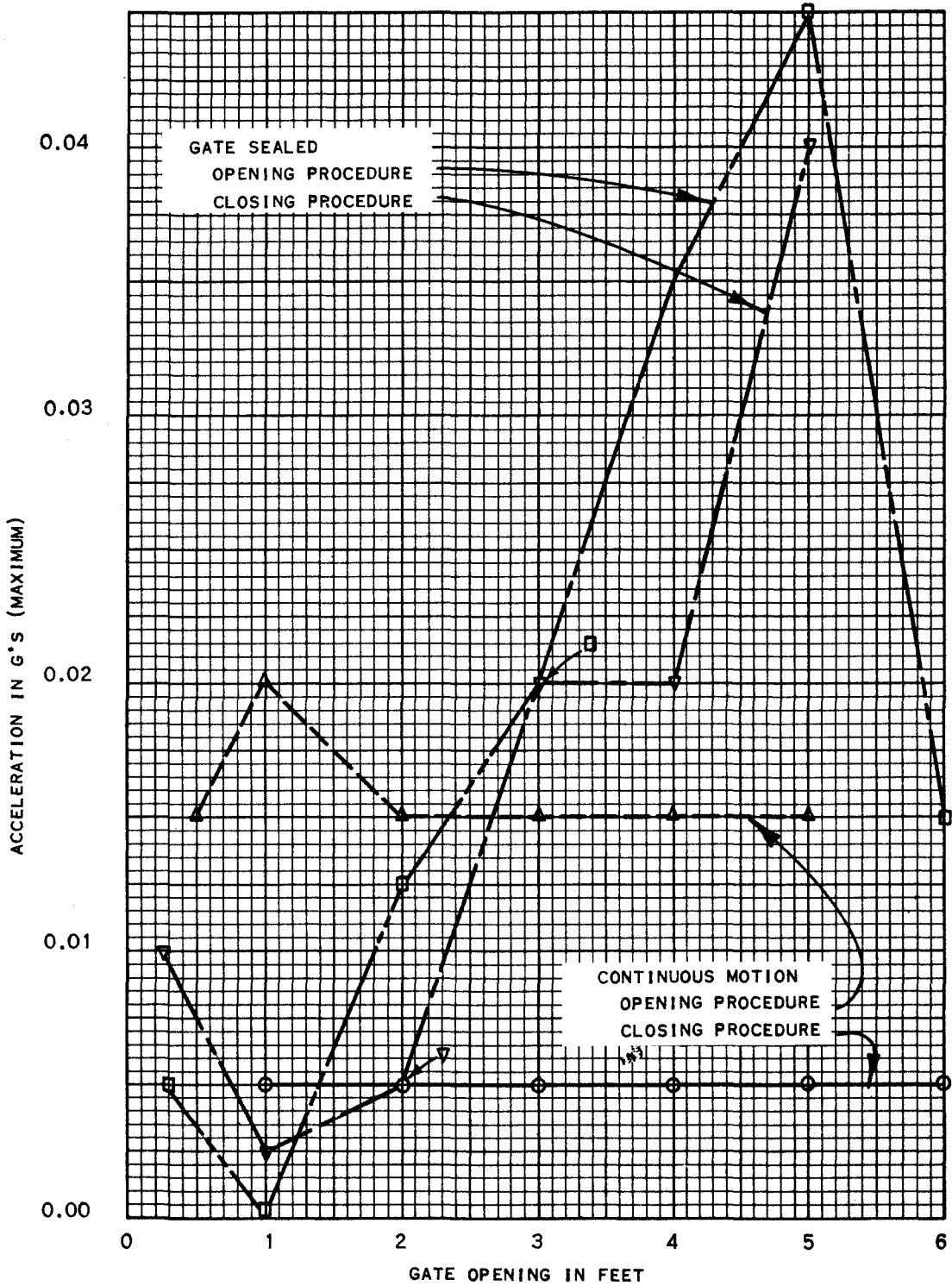

VIBRATION CHARACTERISTICS
 VERTICAL DIRECTION
 ECCENTRIC TRUNNION-TYPE GATE

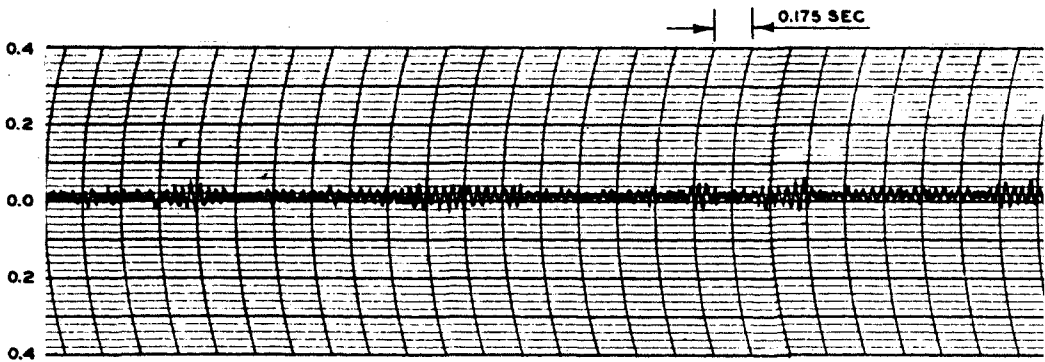

VERTICAL VIBRATION

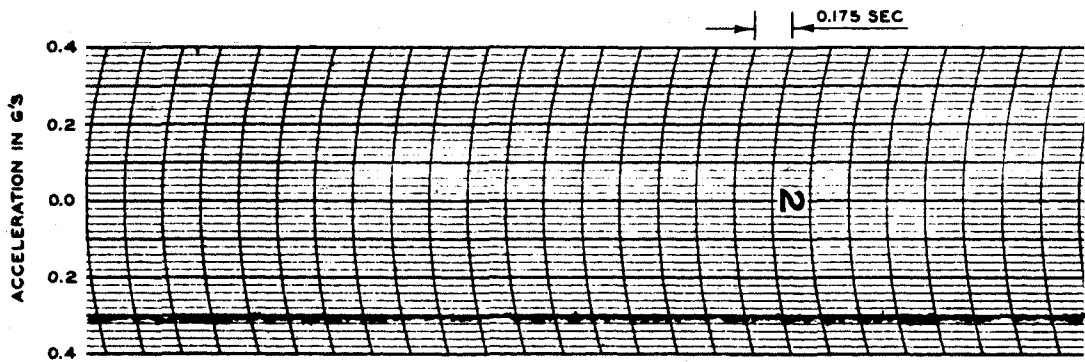

LONGITUDINAL VIBRATION

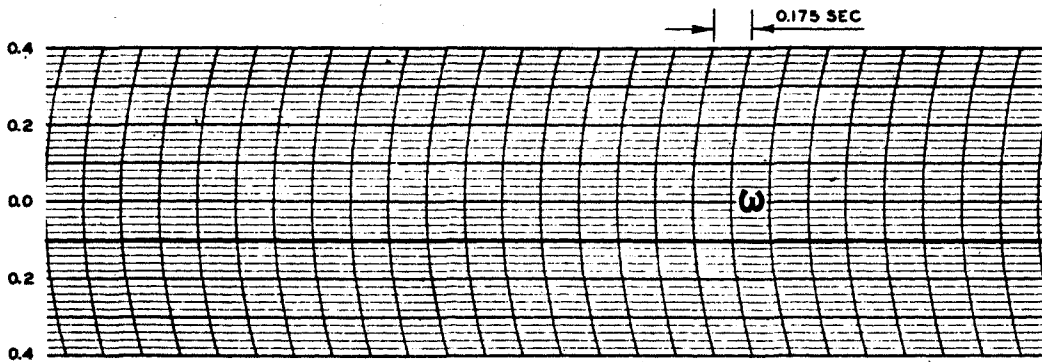

TRANSVERSE VIBRATION

TYPICAL VIBRATION RECORDS
 GATE SEALED AT 5-FT OPENING
 OPENING PROCEDURE

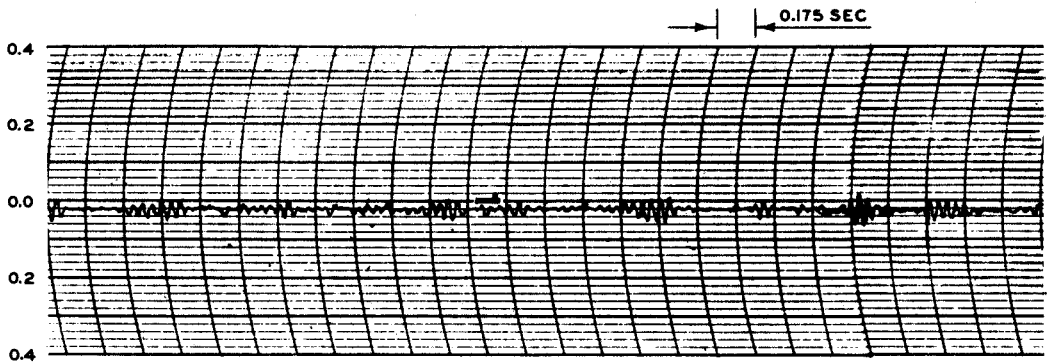

VERTICAL VIBRATION

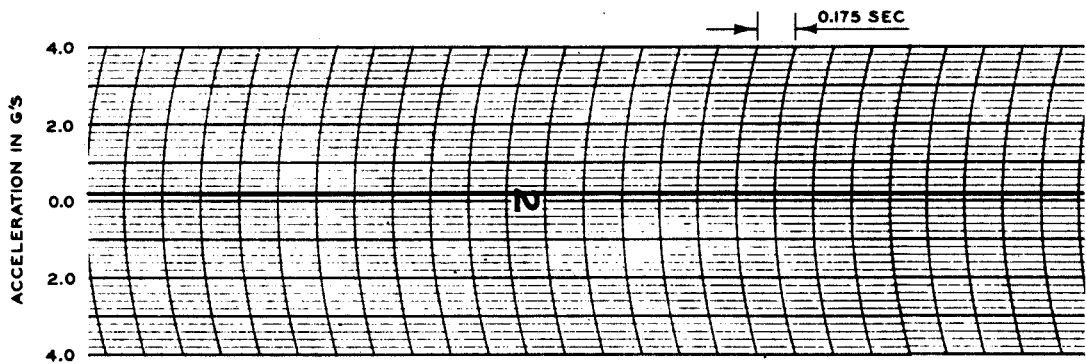

LONGITUDINAL VIBRATION

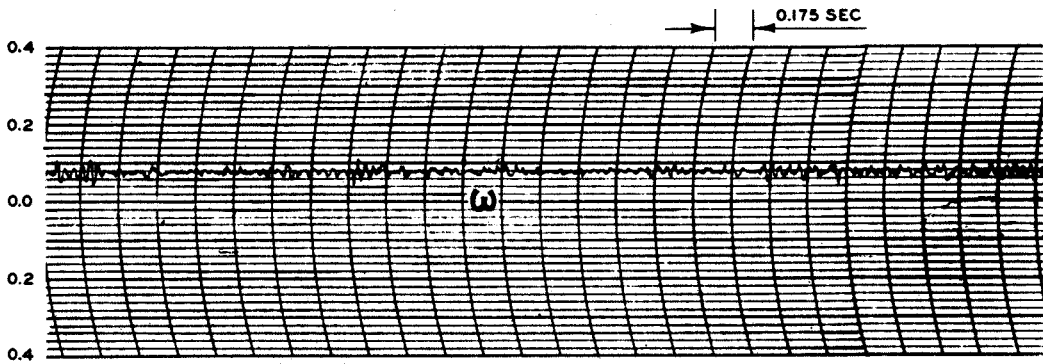

TRANSVERSE VIBRATION

TYPICAL VIBRATION RECORDS
 GATE SEALED AT 5-FT OPENING
 CLOSING PROCEDURE

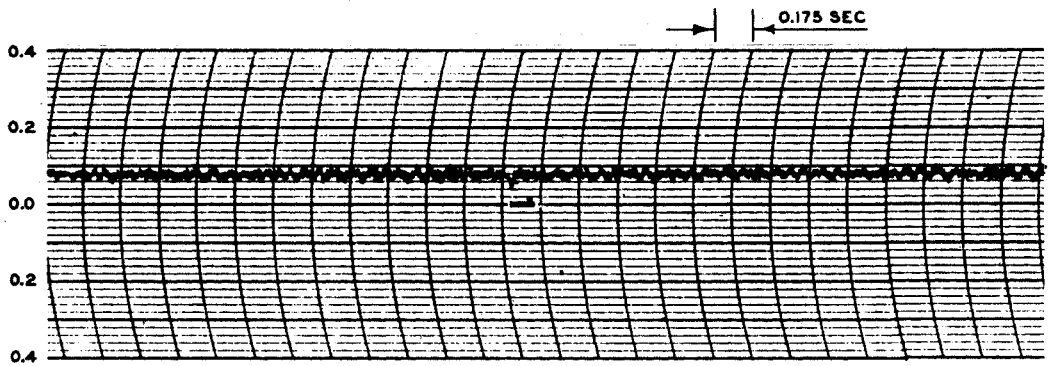

VERTICAL VIBRATION

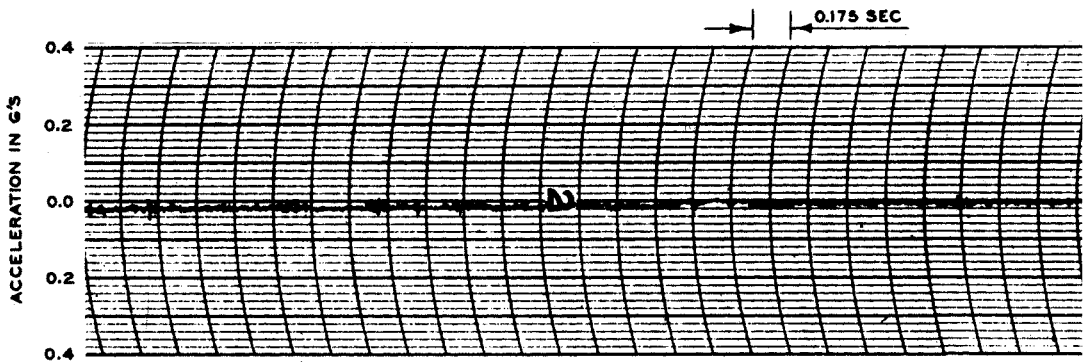

LONGITUDINAL VIBRATION

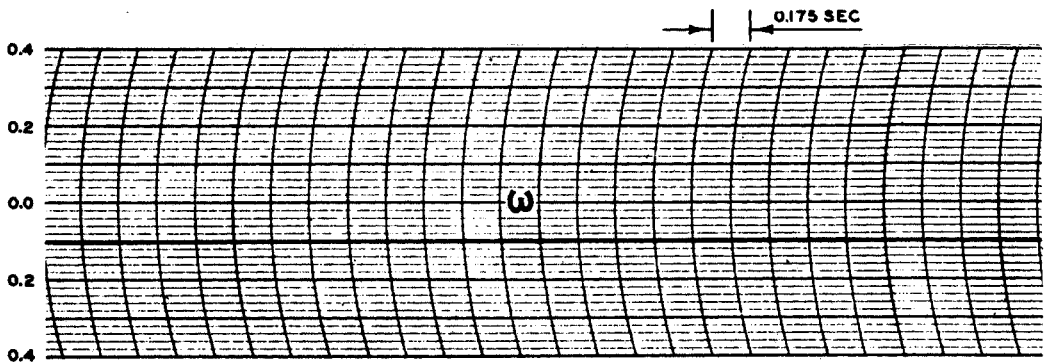

TRANSVERSE VIBRATION

TYPICAL VIBRATION RECORDS
CONTINUOUS MOTION
5-FT GATE OPENING
CLOSING PROCEDURE

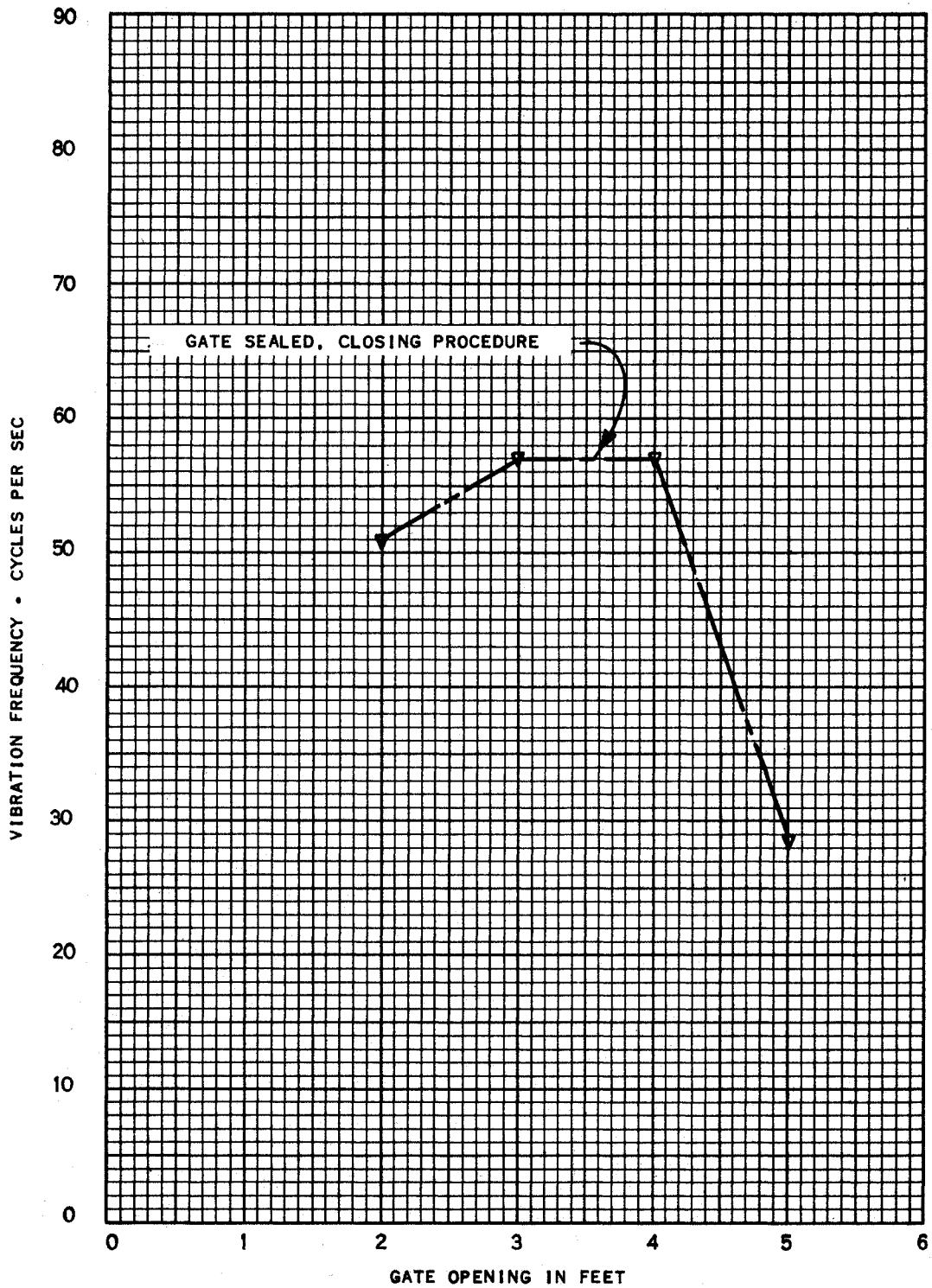

VIBRATION FREQUENCY CHARACTERISTICS
 TRANSVERSE DIRECTION
 ECCENTRIC TRUNNION-TYPE GATE

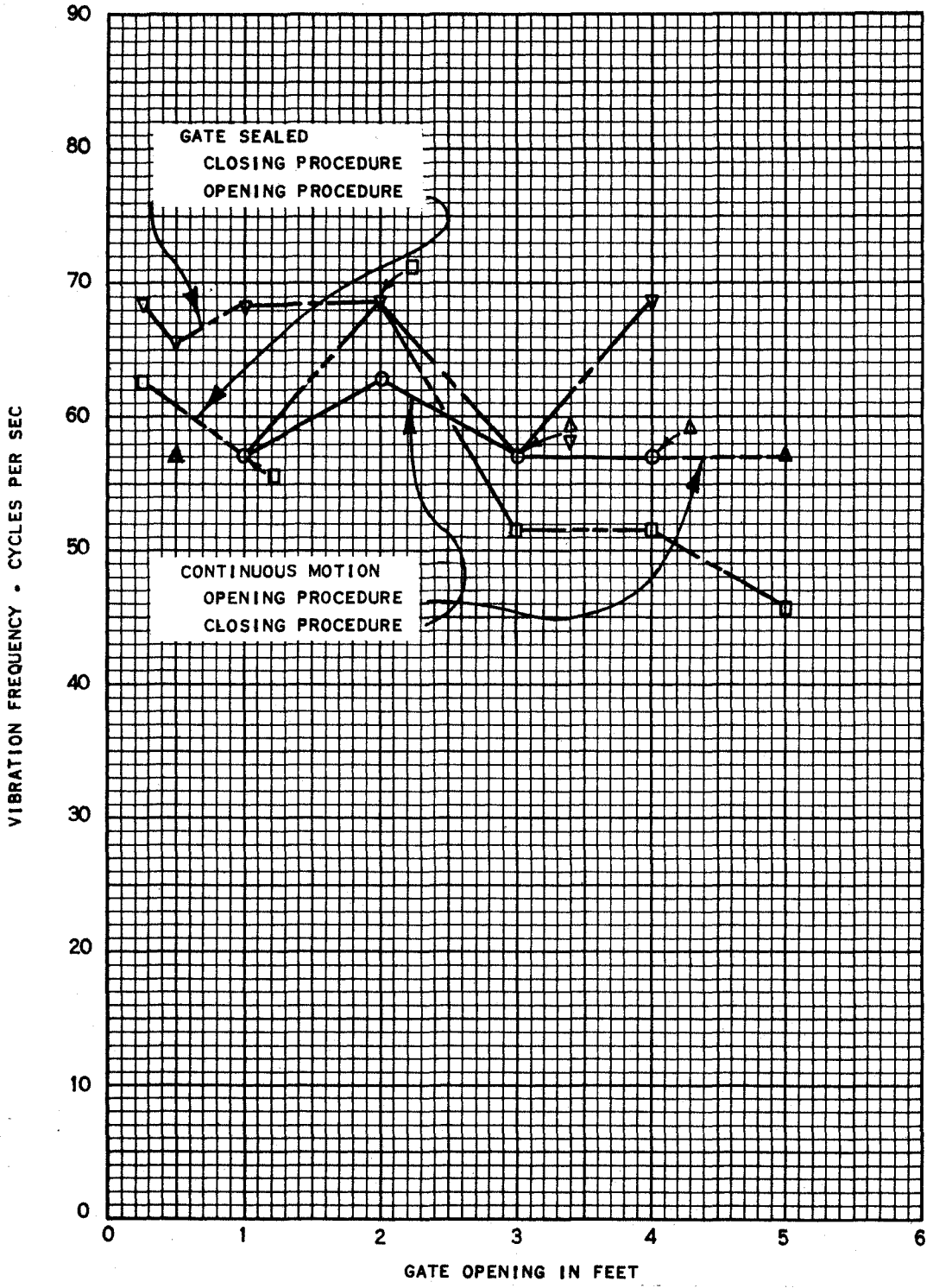

VIBRATION FREQUENCY CHARACTERISTICS
 LONGITUDINAL DIRECTION
 ECCENTRIC TRUNNION-TYPE GATE

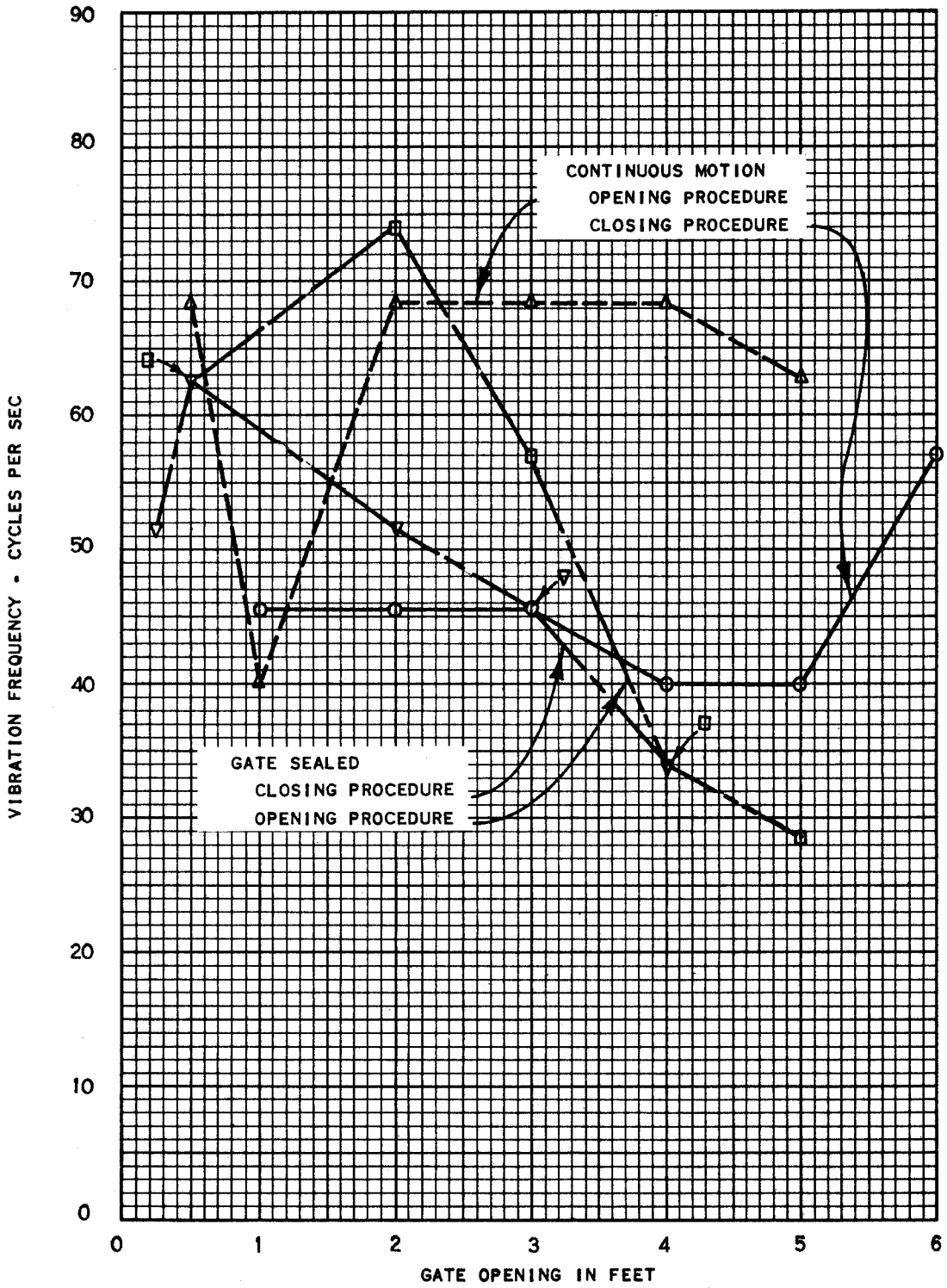

VIBRATION FREQUENCY CHARACTERISTICS
 VERTICAL DIRECTION
 ECCENTRIC TRUNNION-TYPE GATE

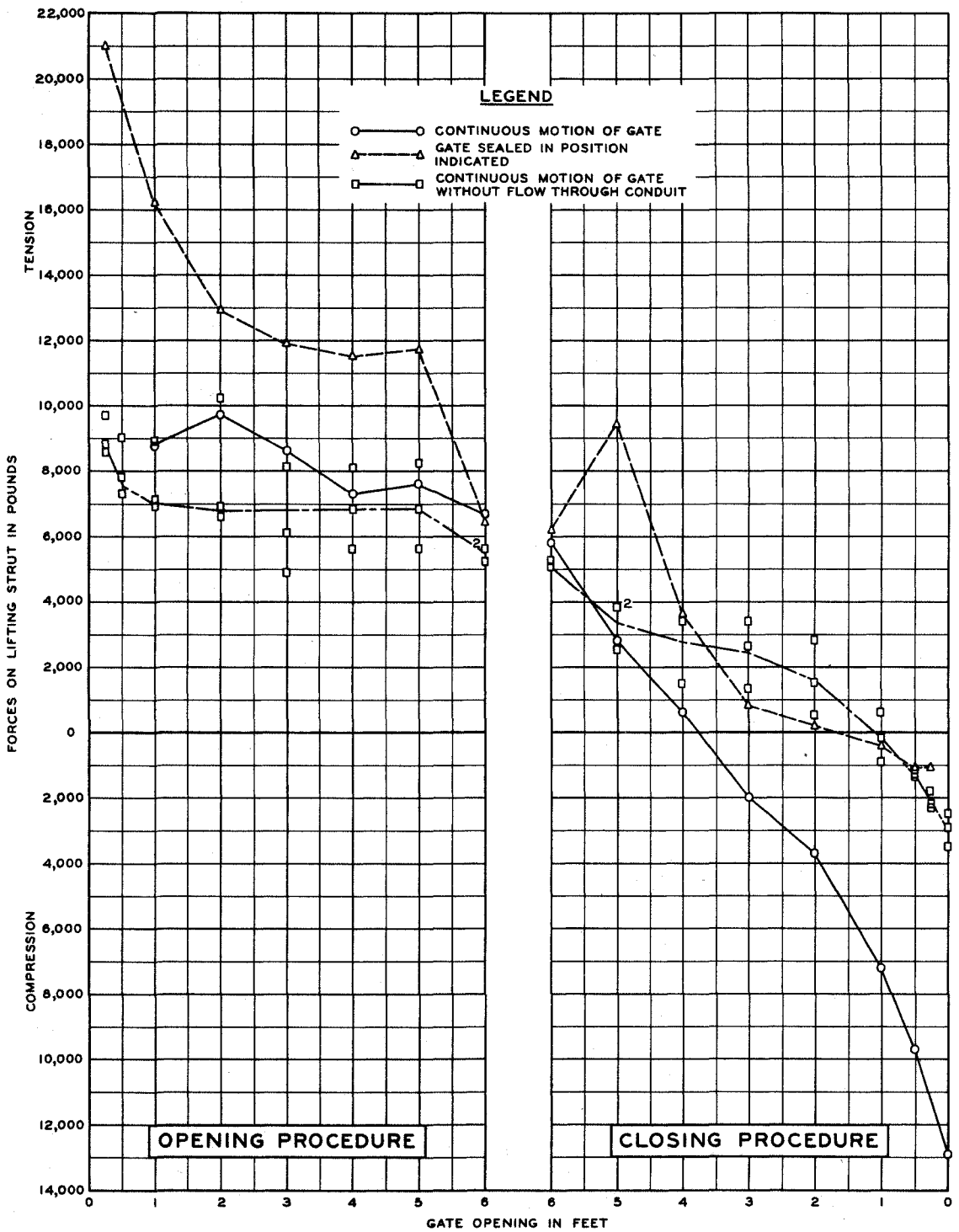

**FORCES ON LIFTING STRUT
ECCENTRIC TRUNNION-TYPE GATE**