

DEVELOPMENT OF A 600 kV MARX MODULE FOR A
HIGH-DENSITY Z-PINCH EXPERIMENT

Ralph W. Kewish, Jr.
Los Alamos National Laboratory
Mail Stop 644
Los Alamos, New Mexico 87545

Summary

A 600 kV Marx generator has been designed with a self-inductance of $1.4 \mu\text{H}$. Two generators in parallel form a module with a self-inductance of 700 nH . Initial operation will be with twelve $0.2 \mu\text{f}$ capacitors giving 12 kJ of stored energy and capable of a short circuit current of 125 kA . These capacitors may be exchanged for $0.43 \mu\text{f}$ units to double the stored energy and current capability. Criteria for switch operating conditions with the working gas, air, and operating pressure, $< 50 \text{ psig}$, were achieved.

Introduction

For several years, personnel at the Los Alamos National Laboratory have operated a small high-density Z-pinch experiment powered by a 5-ohm water transmission line, 60 ns long, operating at 600 kV . They have demonstrated successful initiation of plasma channels (200μ diameter) and have measured plasma temperatures of 250 eV and plasma densities of $\sim 10^{20} \text{ cm}^{-3}$. Further, the expansion of the plasma arc channel described by MHD calculations is in agreement with the Schlieren photography measurements.

In this experiment, the current reached 90 kA in about 20 ns then began to deviate from the signature required to maintain plasma equilibrium.¹ Following the achievements of this experiment and because of the reactor possibilities, a proposal was submitted to build a machine with an initial phase reaching $300\text{--}500 \text{ kA}$ in $\sim 200 \text{ ns}$ with the proper waveform for plasma field pressure balance.

Energy Source

Pulse charging the water transmission line requires a 600 kV power source of about 12 kJ . A further requirement is that the power source be capable of charging the transmission line in less than 500 ns . The obvious choice for the power source was a Marx generator with the following design requirements:

$$\begin{aligned} V &= 600 \text{ kV} \\ L &< 750 \text{ nH} \\ E &= 12 \text{ kJ} \end{aligned}$$

The stringent requirement on the inductance grew out of a desire to eliminate a pulse charged stage common to other HDZP designs and charge the water transmission line directly.

Marx Generator Design

Marx generators are convenient for pulsed power applications for a number of reasons. The most obvious is that the dc power supply used for charging the capacitors can be considerably lower in voltage than the output voltage of the erected Marx. Likewise, the components are generally all rated for a voltage much lower than the erected Marx voltage. A simple Marx generator is shown in Figure 1. An

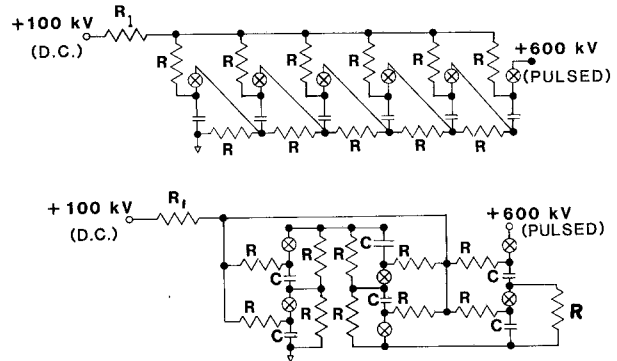
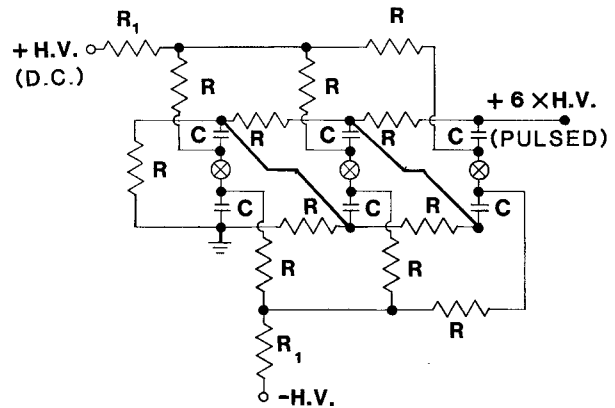

Figure 1
Simple Marx generator.



H.V. MARX GENERATOR

Figure 2
Marx design using \pm H. V. charging.

alternative design, shown in Figure 2, reduces the number of switches by half. The advantage in this second design is that there is less jitter in the Marx erection and possibly less total inductance. Since the switches carry almost equivalent currents, there is no advantage in having more switches. Also, there is no greater electrical stress on the capacitors in the second design. The major problem is that the switches must hold off twice the voltage so, consequently, designs had to be carefully scrutinized to avoid possible prefire problems. The choice of this design necessitated the development of a 200 kV switch.

Report Documentation Page

Form Approved
OMB No. 0704-0188

Public reporting burden for the collection of information is estimated to average 1 hour per response, including the time for reviewing instructions, searching existing data sources, gathering and maintaining the data needed, and completing and reviewing the collection of information. Send comments regarding this burden estimate or any other aspect of this collection of information, including suggestions for reducing this burden, to Washington Headquarters Services, Directorate for Information Operations and Reports, 1215 Jefferson Davis Highway, Suite 1204, Arlington VA 22202-4302. Respondents should be aware that notwithstanding any other provision of law, no person shall be subject to a penalty for failing to comply with a collection of information if it does not display a currently valid OMB control number.

1. REPORT DATE JUN 1981	2. REPORT TYPE N/A	3. DATES COVERED -	
4. TITLE AND SUBTITLE Development Of A 600 Kv Marx Module For A High-Density Z-Pinch Experiment		5a. CONTRACT NUMBER	
		5b. GRANT NUMBER	
		5c. PROGRAM ELEMENT NUMBER	
6. AUTHOR(S)		5d. PROJECT NUMBER	
		5e. TASK NUMBER	
		5f. WORK UNIT NUMBER	
7. PERFORMING ORGANIZATION NAME(S) AND ADDRESS(ES) Los Alamos National Laboratory Mail Stop 644 Los Alamos, New Mexico 87545		8. PERFORMING ORGANIZATION REPORT NUMBER	
9. SPONSORING/MONITORING AGENCY NAME(S) AND ADDRESS(ES)		10. SPONSOR/MONITOR'S ACRONYM(S)	
		11. SPONSOR/MONITOR'S REPORT NUMBER(S)	
12. DISTRIBUTION/AVAILABILITY STATEMENT Approved for public release, distribution unlimited			
13. SUPPLEMENTARY NOTES See also ADM002371. 2013 IEEE Pulsed Power Conference, Digest of Technical Papers 1976-2013, and Abstracts of the 2013 IEEE International Conference on Plasma Science. Held in San Francisco, CA on 16-21 June 2013. U.S. Government or Federal Purpose Rights License.			
14. ABSTRACT			
15. SUBJECT TERMS			
16. SECURITY CLASSIFICATION OF:			17. LIMITATION OF ABSTRACT SAR
a. REPORT unclassified	b. ABSTRACT unclassified	c. THIS PAGE unclassified	
			18. NUMBER OF PAGES 4
			19a. NAME OF RESPONSIBLE PERSON

Switch Development

Because of its symmetry, a field distortion switch design was chosen. We pooled the empirical knowledge of a number of people to obtain the mechanical design. After several sessions, we agreed upon the design in Figure 3 as the most probable for success in the given situation.²

The electrodes of the switch are adapted from Scyllac spark gap electrodes having a radius of curvature of 7.5 cm over the portion where arc channels are expected to occur. Two designs were tested having electrode separations of 1.9 cm and 2.54 cm. The pressure chamber is cylindrical, 15.2 cm in diameter and 21.6 cm long. All sharp edges except for the trigger electrode have been relieved to minimize poor performance and arcing to other components in this high field stress situation.

We ascertained the criteria for considering a design acceptable were threefold. First, the jitter of the switch, defined later, should be on the order of 10 ns. Second, the operating pressure be less than 50 psig (350 kPa) with a potential difference across the switch of 200 kV. Third, the working gas should be air, a personal prejudice of the users of the Marx generators.

Figure 4 shows the test configuration we used to determine the switch's static breakdown curve. The biasing resistors ranged from 0Ω to several hundred megohms. On one data run, the trigger electrode was allowed to float, and no appreciable difference from results with bias was observed.

Encouraging results were obtained from the first static breakdown curves, 2.54 cm electrode spacing, as shown in Figure 5. A curve for the 1.9 cm spacing is also shown, Figure 5. An empirical rule of thumb for operating a field distortion switch at a desired voltage is that the ratio of the operating pressure to the self-breakdown pressure be on the order of 1.25;

$$\frac{P_{\text{operating}}}{P_{\text{self-break}}} \sim 1.25 .$$

From these results we could predict that (provided jitter was acceptable) the switch could be run at less than 50 psig (350 kPa) fill pressure.

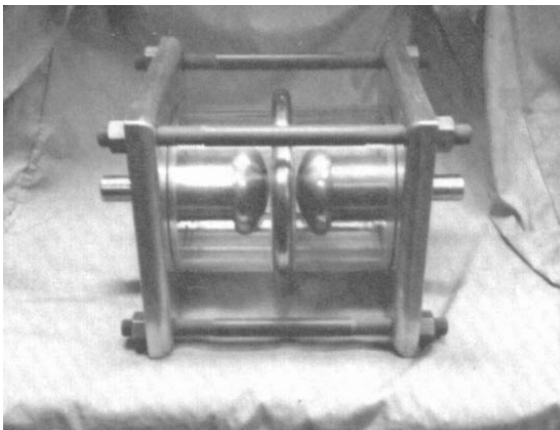

Figure 3
200 kV field distortion switch.

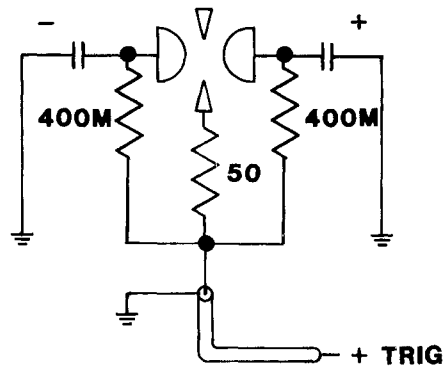

Figure 4
Static breakdown test circuit.

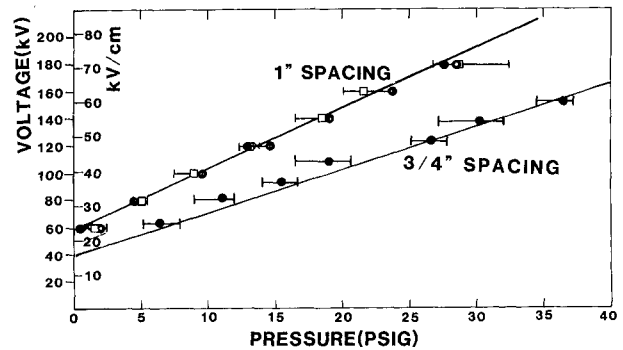

Figure 5
Static breakdown curve for 2.54 cm (1") and 1.9 cm (3/4") electrode spacing.

Triggering of the gap is accomplished by using a high-voltage pulse from a small trigger Marx generator ("micro-Marx") that is low energy (~ 10 J) and high-voltage (200 kV). This Marx triggering unit has the advantage of producing a voltage pulse that is fully erect before the field distortion switch begins to conduct. Lab tests show the trigger Marx pulse rises at a rate of about 50 kV/ns.

Figure 6 shows the test arrangement for determining the switch jitter. Because the switch triggers so soon after the Marx trigger, the beginning of the light pulse trace cannot be seen on the measuring oscilloscope. An extra 30.5 meters of fiber optic cable was included to approximately center the pulse in the oscilloscope screen, thus avoiding the use of a Delay generator.

The switch's jitter is defined as two times the standard deviation as determined from the variation of the measured delay between the output of the trigger Marx ("micro-Marx" triggering unit) and the onset of detectable light from the triggered field distortion switch. A typical trace is shown in Figure 7. Measurements were made for 2.54 cm and 1.9 cm spacing

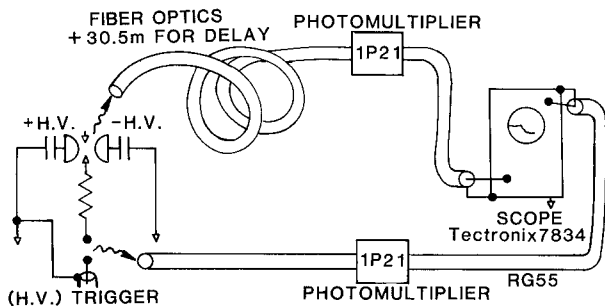

Figure 6
Schematic for jitter tests.

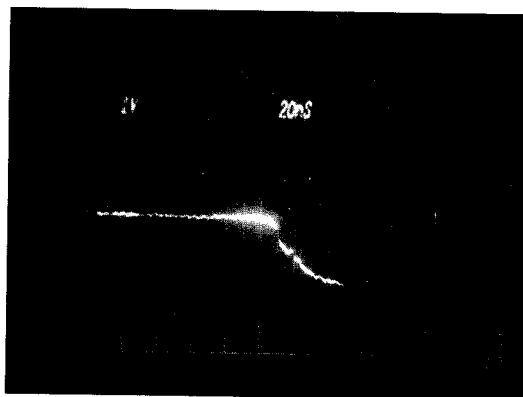

Figure 7
Oscilloscope trace showing the output of a photo-multiplier tube indicating switch closure.

at optimum operating pressure. The following results were obtained:

Spacing	Jitter
2.54 cm	11.3 ns
1.9 cm	9.8 ns

Marx Model

From early estimates, we determined that the minimum inductance of the design in Figure 2 would be 1.3 μH . Therefore, it was imperative to keep all clearances between components in the mechanical assembly to a minimum. A more exact measurement of the inductance was desirable to calculate the charge time of the water transmission line. A full scale model using six .43 μf capacitors was built to measure the inductance, Figure 8.

Since this was a test circuit, it was not put in a tank and submerged in insulating oil as the actual Marx generator would be. So the charge voltage was much lower than the voltage in the working system. The charge voltage for the tests was ± 9.0 kV, giving a full erected Marx voltage of 54 kV. With no load, the

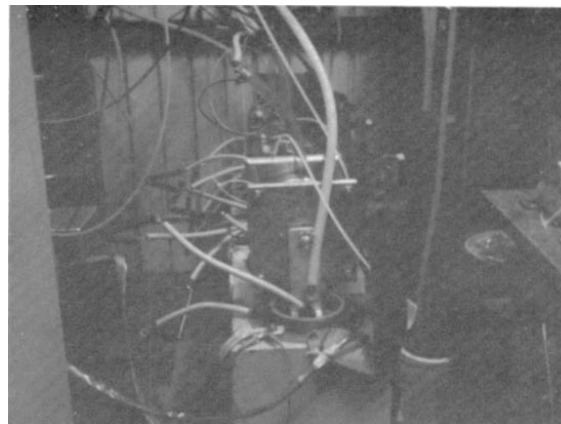

Figure 8
Full scale Marx model for checking inductance.

short circuit ringing period was 2.0 μs giving a self-inductance of

$$L = 1.4 \mu\text{H} .$$

HDZP Marx Module

With a reliable switch fairly well established and a model with an inductance which was within a factor of two of that desired, a Marx for actual use could be designed. To reduce the inductance of the Marx, Figure 2, two Marx units were connected in parallel, Figure 9, forming a module and thus reducing the inductance by a factor of two.

Figure 10 and 11 show the HDZP Marx module before the tank was filled with insulating oil. Notice that the output electrode consists of two wide metal bars connected at the high voltage output folded back and tapering together toward the low voltage and toward the Marx output. This configuration reduced the inductance while at the same time maintaining voltage hold off capability. In Figure 11, the vertical metal cylinder is the trigger micro-Marx for initiating HDZP Marx erection. The risetime of this trigger Marx, different from the Marx used in switch testing, is > 80 kV/ns.³

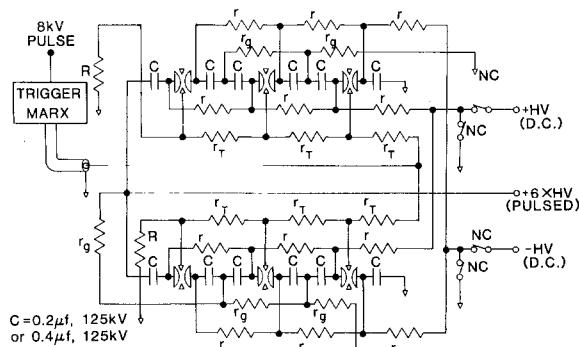

Figure 9
HDZP Marx module circuit diagram.

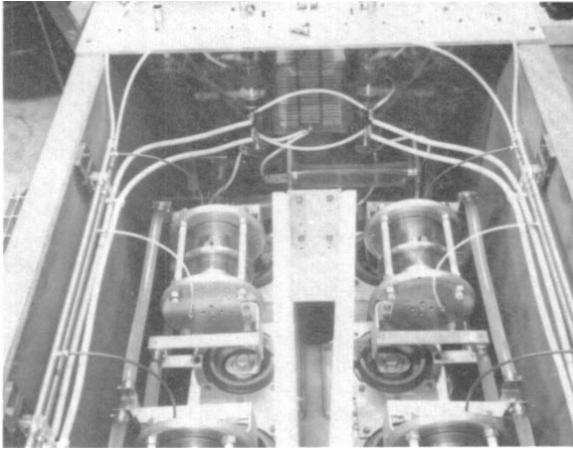

Figure 10
Marx module showing connection between
Marx unit outputs.

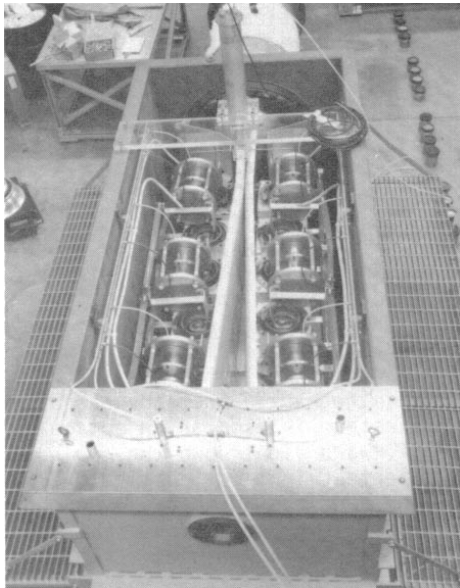

Figure 11
Marx module with trigger Marx unit.³

Acknowledgements

I wish to thank Alex Velasquez for his valuable technical assistance.

Work performed under the auspices of the U. S. Department of Energy.

References

1. J. S. Schlachter and J. E. Hammel, "Observations on Laser Initiated High-Density Z-Pinch Plasmas," Los Alamos National Laboratory 5E3, 22nd Annual Meeting of the Division of Plasma Physics, San Diego, 1980.
2. R. F. Gribble, J. E. Hammel, C. F. Hammer, J. S. Schlachter, private communication.

3. D. A. Platts, "10 Joule High-Voltage Trigger Micro Marx," Los Alamos National Laboratory, Paper 26.2, 3rd IEEE International Pulsed Power Conference, Albuquerque, 1981.