

TC 58
45882
TM-2-256

DEPARTMENT OF THE ARMY
CORPS OF ENGINEERS
MISSISSIPPI RIVER COMMISSION

IMPROVEMENT OF FREEBOARD CONDITIONS
ON PONTONS IN HIGH-VELOCITY FLOW

MODEL INVESTIGATION

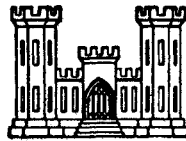

TECHNICAL MEMORANDUM NO. 2-256

WATERWAYS EXPERIMENT STATION
VICKSBURG, MISSISSIPPI

1 JUL 1948

12 JUL 1948

MRC-WES-200-6-48

JUNE 1948

Report Documentation Page

Form Approved
OMB No. 0704-0188

Public reporting burden for the collection of information is estimated to average 1 hour per response, including the time for reviewing instructions, searching existing data sources, gathering and maintaining the data needed, and completing and reviewing the collection of information. Send comments regarding this burden estimate or any other aspect of this collection of information, including suggestions for reducing this burden, to Washington Headquarters Services, Directorate for Information Operations and Reports, 1215 Jefferson Davis Highway, Suite 1204, Arlington VA 22202-4302. Respondents should be aware that notwithstanding any other provision of law, no person shall be subject to a penalty for failing to comply with a collection of information if it does not display a currently valid OMB control number.

1. REPORT DATE JUN 1948	2. REPORT TYPE	3. DATES COVERED 00-00-1948 to 00-00-1948			
4. TITLE AND SUBTITLE Improvement of Freeboard Conditions on Pontons in High-velocity Flow: Model Investigation		5a. CONTRACT NUMBER			
		5b. GRANT NUMBER			
		5c. PROGRAM ELEMENT NUMBER			
6. AUTHOR(S)		5d. PROJECT NUMBER			
		5e. TASK NUMBER			
		5f. WORK UNIT NUMBER			
7. PERFORMING ORGANIZATION NAME(S) AND ADDRESS(ES) U.S. Army Corps of Engineers, Waterway Experiment Station, 3903 Halls Ferry Road, Vicksburg, MS, 39180		8. PERFORMING ORGANIZATION REPORT NUMBER			
9. SPONSORING/MONITORING AGENCY NAME(S) AND ADDRESS(ES)		10. SPONSOR/MONITOR'S ACRONYM(S)			
		11. SPONSOR/MONITOR'S REPORT NUMBER(S)			
12. DISTRIBUTION/AVAILABILITY STATEMENT Approved for public release; distribution unlimited					
13. SUPPLEMENTARY NOTES					
14. ABSTRACT					
15. SUBJECT TERMS					
16. SECURITY CLASSIFICATION OF:			17. LIMITATION OF ABSTRACT	18. NUMBER OF PAGES	19a. NAME OF RESPONSIBLE PERSON
a REPORT unclassified	b ABSTRACT unclassified	c THIS PAGE unclassified	Same as Report (SAR)	103	

CONTENTS

	<u>Page</u>
SYNOPSIS	
PART I: INTRODUCTION	
History.	3
Problem.	4
Authorization and Personnel.	6
PART II: THE MODELS	
Model-Prototype Scale Relationships.	8
Description.	8
Test Procedure	10
Presentation of Test Results	12
PART III: DESCRIPTION OF TESTS	
M4 Ponton.	14
Modified M4 Ponton	19
Hollow "V" Ponton.	20
Double "V" Ponton.	25
Type "A" Scow Bow Ponton	30
Type "B" Scow Bow Ponton	35
PART IV: DISCUSSION OF TEST RESULTS	
TABLES 1-23	
PLATES 1-34	

IMPROVEMENT OF FREEBOARD CONDITIONS ON PONTONS

IN HIGH-VELOCITY FLOW

Model Investigation

SYNOPSIS

Model studies of pontoons used in the construction of floating military bridges were conducted at the Waterways Experiment Station during 1945-1946 for the Engineer Board, Fort Belvoir, Virginia. The general purpose of the studies was to develop a ponton bow shape to increase freeboard on the bow and sides when used with (a) individual pontoons, (b) pontoons normally spaced in a bridge (15-ft centers), and (c) pontoons closely spaced in a fully reinforced bridge (7.5-ft centers). Of particular concern was the improvement of side freeboard conditions on the M4 ponton when used in a raft or bridge.

All tests were conducted on pontoons constructed to a scale of 1:15 and located in a flume 4 ft wide with the flow maintained at a depth equivalent to 20 ft in the prototype. To investigate the expected performance of adjacent pontoons in a floating bridge, rafts of four- and seven-ponton units were constructed and tested in the model.

It was determined from the model study that, while the present M4 ponton performed satisfactorily as a single ponton unit, its performance in high-velocity flow when used as a support for rafts or bridges was inadequate. The wave formed by the bow of the pontoons, being restricted to the narrow space between pontoons, resulted in a rapid loss of freeboard in this area. In order to improve conditions when the pontoons are

used in a raft or bridge, it was found necessary to flatten the rake of the bow and to increase the frontal area so as to direct a larger percentage of the flow under the pontoons rather than along the sides. The flat rake and increased frontal area resulted in full use of the dynamic force of the stream as a lifting factor. The design providing best freeboard conditions at the bow and on the sides of pontoons in a raft incorporated a scow bow shape and has been designated in this report as the type "B" scow bow ponton.

PART I: INTRODUCTION

History

1. The use of floating bridges constructed of vessels having a roadway of beams and planks has long been an important factor in the ability of an army to successfully move troops and equipment from place to place. So long as rolling equipment was drawn by animals the weight of vehicles was limited and consequently the strength required of military bridges remained approximately constant until the beginning of the twentieth century. With the introduction of motor vehicles and tanks, weights increased rapidly and all bridging standards had to be reconsidered. During World War II, further advances were made in the development of heavy equipment. Bridging standards, however, failed to keep stride with the rapid advancement of heavy equipment and it was discovered that the standard 25-ton American ponton used as support in floating bridges was incapable of supporting such equipment, especially over streams where high-velocity flow existed. As the pontons were subjected to the tremendous weight of large tanks or heavy artillery pieces, little or no freeboard existed and, when loading occurred in high-velocity flow, the blunt shape of the bow resulted in a large bow wave which sank the ponton. It therefore became necessary to redesign ponton equipment.

2. As the 25-ton American ponton was to be the basis for the redesign of ponton equipment, exhaustive testing of full-scale pontons was carried on at the Desert Test Section of the Engineer Board at Yuma, Arizona. During June 1943 concurrent tests on model pontons were

undertaken at the Experiment Station* to develop a bow shape that would improve freeboard conditions on the pontoons under heavy loading and high-velocity flow; tests concerning design improvement of the M1 pneumatic float were also undertaken. All model tests were conducted, as described herein, on single pontoons and floats without bridge superstructure and constructed to a linear scale of 1:8.

3. Results of the initial test series with single pontoons revealed that to increase freeboard conditions at the bow either of two methods could be used: (a) the rake of the bow could be flattened or (b) the height of the bow could be increased. The test data further revealed that the shape of the bow in plan (streamlining) had little effect in improving freeboard conditions. Subsequent tests conducted at the Stevens Institute of Technology under the direction of Sparkman and Stephens, Incorporated, indicated that if the bow were streamlined in plan from the bottom to the top of the ponton, some improvement in freeboard would be effected. The resulting ponton was the M4 design described in paragraph 13.

Problem

4. Following the development and construction of the M4 type ponton, full-scale tests conducted by the Engineer Board at the Desert Test Section, Yuma, Arizona, revealed that streamlining the bow in plan had certain disadvantages that were not apparent with pontoons having about the same rake of bow but rectangular in plan (see fig. 1). Although the

* Waterways Experiment Station T.M. 215-1, "Model Study of Pontoons and Pneumatic Floats", March 1945.

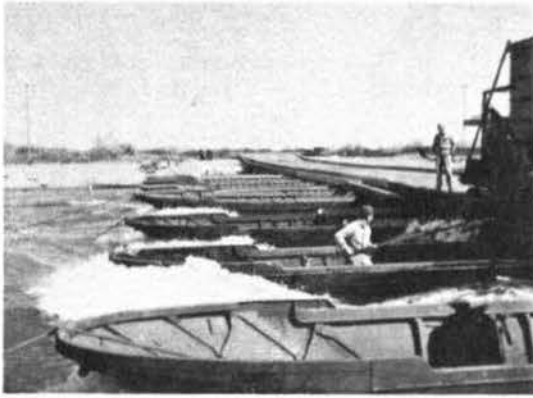

45-ton load on center line
 Current of approximately 11 fps
 Side freeboard, still water, 15 in.



55-ton load on center line
 Current of approximately 10 fps
 Side freeboard, still water, 11 in.

Load on center line of normal floating bridge M4



Two-ponton M4 raft -- normal spacing
 Pontons with 10-in. freeboard in still water being towed about 8 fps



Two-ponton M4 raft -- normal spacing
 Pontons with 14-in. freeboard in still water being towed about 12 fps

Figure 1. Floating bridge, M4

curved bow of the M4 ponton resulted in increased freeboard at the bow, when placed in a raft or in a bridge, the wave from the bows of adjacent pontons resulted in a build-up of flow between pontons immediately upstream from the bridge decking which overtopped the sides of the pontons. In the case of pontons rectangular in plan the build-up of flow between pontons when used in a bridge or raft was not as great and considerably more freeboard existed on the sides. Therefore, the general purpose of the present series of model tests was to study various types of ponton bows proposed by the Engineer Board when used with: (a) individual pontons, (b) pontons spaced in the standard bridge, and (c) pontons spaced as in a fully reinforced bridge.

Authorization and Personnel

5. Authority to conduct the model study of pontons was granted by the Chief of Engineers, U. S. Army, in a letter dated 13 August 1945. The investigation was conducted by the Waterways Experiment Station during the period September 1945 to August 1946. All details of the pontons and superstructure were furnished by the Engineer Board, Fort Belvoir, Virginia. During the course of the model study close liaison was maintained between the Experiment Station, the Engineer Board, Fort Belvoir, Virginia, and the Engineer Board, Bridge Branch, Desert Test Section, Yuma, Arizona. Interim reports on each type ponton tested were forwarded to the Engineer Board as test results became available. Lt. Colonels Kelseth and G. W. Howard, Major Cowley, and Mr. H. A. Alvig visited the Experiment Station in an advisory capacity at intervals during the testing program. Personnel of the Experiment Station

concerned with the model studies were Messrs. F. R. Brown, J. W. Bolin, E. S. Melsheimer, engineers, and Messrs. S. B. Burns and J. M. Mitchell, engineering aides.

PART II: THE MODELS

Model-Prototype Scale Relationships

6. The accepted equations of hydraulic similitude, based upon the Froudian relationships, were used to express the mathematical relationships between the dimensions and hydraulic quantities of the model and the prototype. The general relationships existing for the models of the pontons are listed below:

<u>Dimension</u>	<u>Scale Ratio</u>
Length	$L_r = 1:15$
Area	$A_r = L_r^2 = 1:225$
Velocity	$V_r = L_r^{1/2} = 4$
Discharge	$Q_r = L_r^{5/2} = 1:872$
Weight	$W_r = L_r^3 = 1:3375$

7. As the previous series of ponton tests at the Experiment Station was conducted on a 1:8 scale and the presently described series on a 1:15 scale, a check test was made to study the effect of scale. This check was made by developing freeboard-velocity curves on the bow and side of an American 25-ton ponton constructed to a scale of 1:15. Comparison of freeboards obtained with the 1:8-scale ponton and the 1:15-scale ponton revealed similar results, indicating that scale effect was negligible.

Description

8. The models of the pontons and the superstructure of the raft

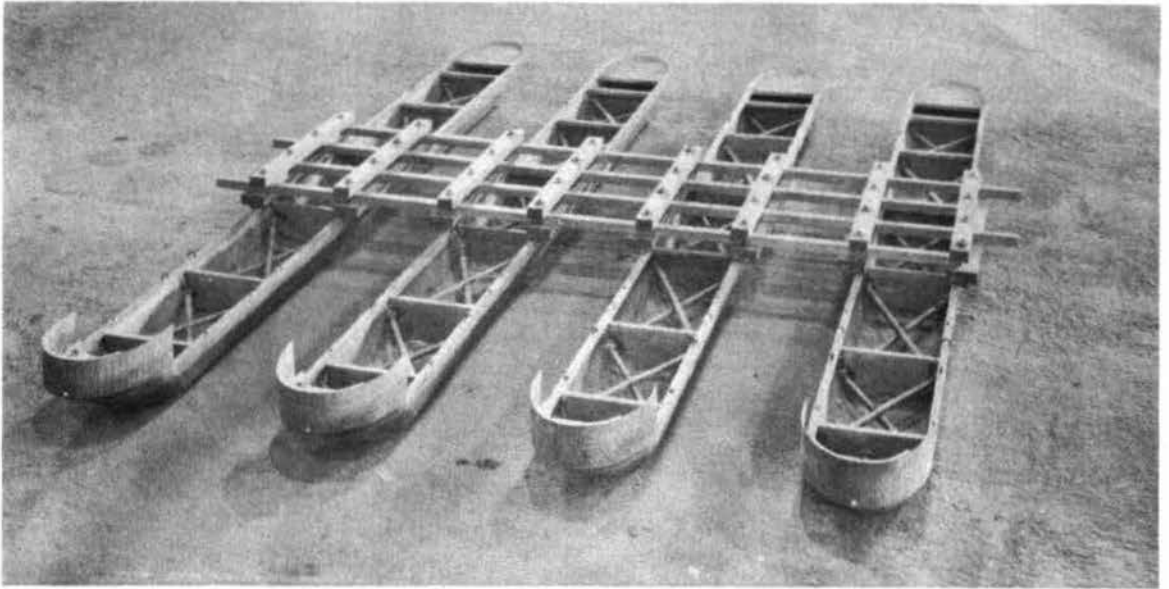

Figure 2. M5 raft with four M4 ponton units

or bridge were constructed to a linear scale ratio of 1:15 (see fig. 2). Initial plans called for the pontoons to be constructed of transparent plastic as had been the practice on the previous model studies. However, it was discovered that while plastic material was suitable for construction of the pontoons when testing was confined to single units, its weight prevented reproduction of prototype deflection characteristics when such pontoons were used as supports in the four-ponton or seven-ponton rafts. To simulate computed prototype raft deflections it became necessary to construct the pontoons of thin zinc sheeting, which was light in weight and easily fabricated. In the construction of the pontoons no attempt was made to reproduce separately each ponton. Instead, each ponton support was constructed as a single over-all unit. As a model testing expedient to procure minimum freeboards without sinking the pontoons, a vertical extension or shield was attached to each bow of the pontoons; this attachment will be noted in all photographs.

flume with the flow maintained at a depth equivalent to 20 ft in the prototype.

11. Various measuring and control devices were used to obtain the necessary data and to control the several variables in the operation.

These variables and the methods of control and measurement were as follow:

- a. Discharge. The correct discharges to secure the desired velocities were introduced into the model flume by means of a battery of pumps discharging through a venturi meter.
- b. Depth of flow. An adjustable tailgate was provided at the end of the flume to maintain the desired depth (20 ft prototype) for all conditions of loading and velocity.
- c. Velocity. All velocity measurements were made with a pitot tube located 16 ft (prototype) upstream from the bow of the ponton. Velocities were measured 18 in. (prototype) below the surface of the water to correspond to prototype measurements and were recorded on a manometer gage containing a fluid which magnified all head differentials, thus minimizing errors in the velocity measurements.
- d. Loading. Prior to the start of a test the pontons, when tested as single units, were loaded to freeboards of 14, 10, or 6 in. on the sides in still water. The loading was accomplished by placing small lead billets in the bottom of the ponton midsection. In testing the four-ponton raft the loading was accomplished by placing lead billets on a 17.5-ft (prototype) base located along the transverse center line of the raft so that freeboards of 14, 10, or 6 in. obtained in still water on the inboard sides of the two center pontons in the raft. In testing the seven-ponton raft loading was accomplished by placing lead billets on a 24-ft (prototype) base located along the transverse center line of the raft so that freeboards of 14, 10, or 6 in. obtained in still water on the sides of the center ponton in the raft. The freeboards on the other pontons in the four-ponton and seven-ponton rafts were governed by deflection of the raft superstructure.
- e. Anchoring. In testing a single ponton an anchor line with a length ten times the depth of flow was connected to the bow of the ponton. A bracket arrangement connected to the ponton and attached to the walls of the flume kept the ponton parallel to the flow and permitted

vertical and horizontal movement with the force of the current. Anchoring the four-ponton or seven-ponton raft was accomplished by using a halter arrangement with an anchor line attached to the bow of each of the outside pontoons. The extension of the raft's superstructure on each side of the outer pontoons until it was almost in contact with the flume wall kept the raft parallel to the flow yet permitted it to move vertically or horizontally with the force of the current.

- f. Freeboard. Freeboard at the bows and sides of the pontoons was measured by means of small aluminum gages made for this purpose; all measurements were made in a vertical direction. Since the pontoons under test moved up and down with the flow, precise measurement of freeboard could not be secured with a single gage reading. Accordingly, the minimum, maximum and average freeboards were obtained at the bows and sides for most test conditions. The minimum and maximum freeboards were based on the mathematical average of several sets of separate gage readings, whereas the average freeboard was based on a series of observed average gage readings. Since the average freeboard was recorded at a particular location on the ponton at which the freeboard appeared to be the least, it has been designated throughout this report as the average minimum freeboard. The minimum and maximum freeboards were secured as a matter of record and the observed average minimum for comparative purposes. The location of the point of measurement at the bow was on the center line of the ponton; the point of measurement of freeboard on the sides of the pontoons varied with different velocities.

Presentation of Test Results

12. Practically all model data are presented in the form of average minimum freeboard-velocity curves or tables based on similar data recorded on the bow and sides of the pontoons. Comparison of these freeboard-velocity data indicates the improvement effected by alterations to the M4 ponton design. In the analysis of data, emphasis also should be given to the lowest average minimum freeboard points measured on the sides of pontoons when used in a raft. In some instances the wave action

between the pontons was more violent, and, although the average wave measurements still indicated considerable freeboard, minimum freeboards were zero.

PART III: DESCRIPTION OF TESTS

M4 PontonDescription

13. The standard M4 ponton has a length of 29 ft 7-5/8 in. (29.635 ft), a width of 6 ft 10-1/2 in. (6.875 ft), and a midsection height of 3 ft 4-1/2 in. (3.375 ft), increased to 3 ft 9-1/16 in. (3.755 ft) at the bow (see fig. 4 and plate 1). The bow has a sloping rake and in plan is elliptical in shape. In common with all the pontons tested the stern is square and provided with connections which permit the use of two pontons connected in tandem to carry heavier loads. In the case at hand the load to be tested was such as to require an additional center section with a square bow and stern. Thus, as tested, the M4 ponton unit consisted of two M4 pontons plus a 21-ft-9-1/8-in. (21.760 ft) center section, making an over-all length of 81 ft 0-3/8 in. (81.031 ft). The above supports plus the superstructure were ultimately to be called the Floating Bridge

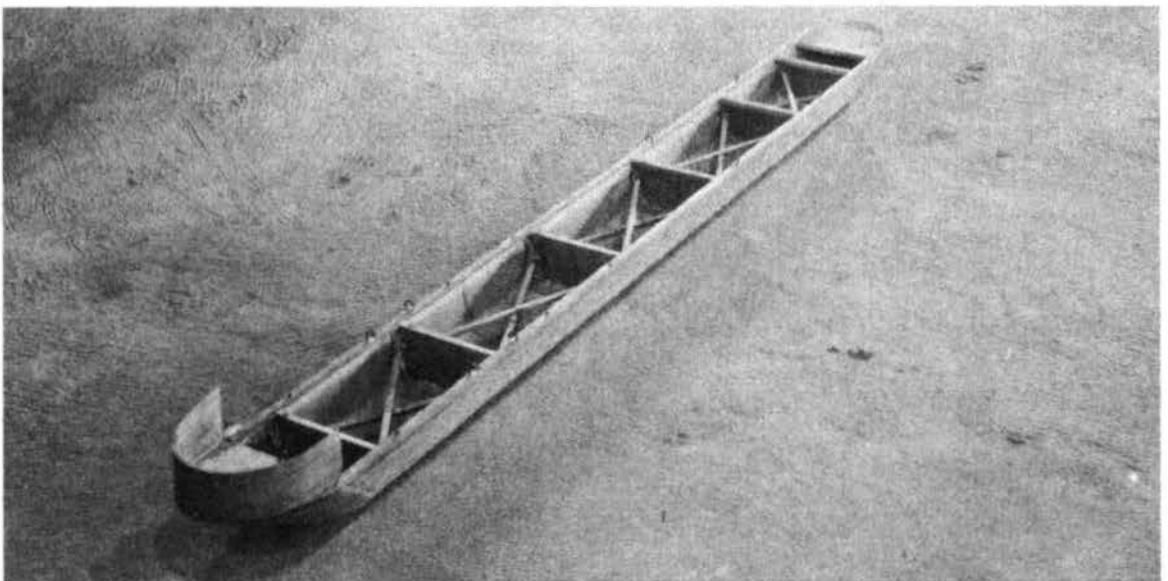

Figure 4. M4 ponton unit

M5. Although the model tests were concerned with this type of bridge, no further work has been done toward its development.

Test results

14. The results of tests with the single M4 ponton are shown on table 1, fig. 5, and plate 1. Average minimum freeboard-velocity curves were developed for the bow and sides of the single ponton under various conditions of velocity and loading for freeboards of 14, 10, and 6 in. on the sides in still water. The tests conducted with the single ponton revealed that the bow was the most critical point in that zero freeboard existed first in this area. Average freeboards on the bow were zero for velocities of 14.4, 11.3, and 8.4 ft per second for loadings of 14, 10, and 6 in., respectively. At the above-mentioned velocities freeboards of 6.7, 4.1, and 2.9 in. still existed on the sides of the ponton. At



Figure 5. Flow conditions for single M4 ponton
Freeboards for velocity of 10.8 fps and 14-in. loading
Bow 10.0 in. Side 10.5 in.

the critical velocity of 12 ft per second freeboards of 7.0 and -1.9 in. existed at the bow and 9.2 and 3.2 in. at the sides for loadings of 14 and 10 in. in still water.

15. Prior to the investigation of the proposed M5 raft, an attempt was made to reproduce in the model the computed prototype raft deflection under a load of 80 tons. A description of the raft superstructure and the method of loading has been presented previously in paragraphs 9 and 11d, and shown on fig. 3. In order to reproduce the desired deflection under load, it was necessary to adjust the flexibility of the decking by loosening or tightening the top cleats holding the pine slats in place. Inspection of plate 2 will show that although the flexural characteristics of the model were not as computed, a close agreement obtained between model and computed prototype deflections.

16. In testing the four-ponton M5 raft with the M4 pontoons as supports (fig. 2), average minimum freeboard-velocity curves were developed with the raft loaded in still water to produce freeboards of 14, 10, and 6 in. on the inboard sides of the two center pontoons. The tests revealed that the average minimum freeboard along the inboard sides of the two center pontoons was 5.5 in. for a velocity of 10.8 ft per second and 14-in. loading; 4.6 in. for a velocity of 8.9 ft per second and a 10-in. loading; and 3.4 in. for a velocity of 7.7 ft per second and a 6-in. loading; the minimum freeboards on the sides for the above conditions of velocity and loading were zero. Also for the above-mentioned velocities and conditions of loading average freeboards of 9.7, 2.6, and 3.1 in. existed on the bow (see plate 3). The freeboard-velocity curves shown on plate 3 were not continued beyond the highest velocity shown because

at that point wave action resulted in a minimum freeboard on the sides of the pontons of zero even though the average minimum freeboard was still several inches. Velocity conditions at which the minimum freeboards on sides were zero are shown in table 23. It is to be noted that at a freeboard loading of 14 in. on the side in still water the side of the ponton was the most critical area in that it was submerged before the bow; at freeboards of 10 and 6 in. on the side in still water the bow and side submerged at about the same time. The location and magnitude of the average minimum freeboard on the inboard side of the center pontons are shown in table 1. As shown on fig. 6, the wave between the pontons, resulting from the bow wave, was clearly discernible. Although the freeboard data developed for the bows and inboard sides of the two outer pontons were not as critical as for the two center pontons, they are presented as a matter of record on plate 4. Average freeboards for the outboard sides of all pontons in the raft may be found in table 2.

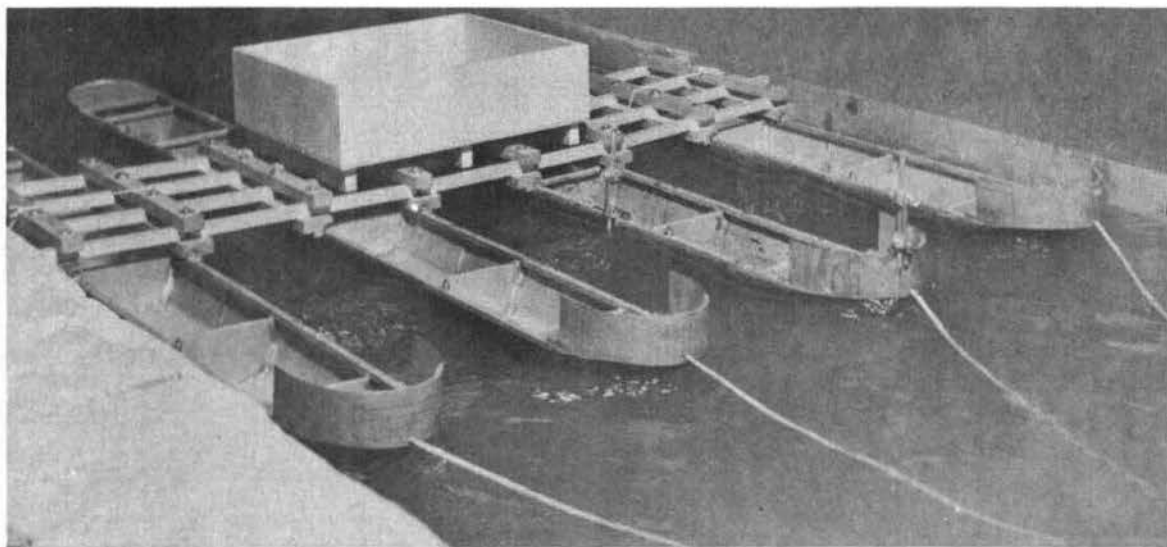

Figure 6. Flow conditions for four-ponton M5 raft
Freeboards for velocity of 10.8 fps and 14-in. loading
Ponton No. 2 bow 9.7 in. Ponton No. 2 starboard side 5.5 in.

17. In order to check the applicability of model results, the freeboard-velocity data procured on the two center pontoons of the four-ponton raft were compared with field data procured by towing a two-ponton raft through still water. In both instances the pontoons were loaded to freeboards of 14, 10, and 6 in. on the side in still water. The data reveal (plate 5) that for still-water loadings of 10 and 6 in. on the side, the freeboards at the bow were in close agreement, whereas the freeboards on the side of the prototype pontoons were less than those recorded in the model under similar conditions. For a still-water loading of 14 in. on the side the freeboards at both bow and sides were less with the prototype pontoons. Check runs of model data gave the same results as previous tests and it was concluded that model measurements were accurate.

18. Although it is difficult to account for the discrepancies in model and prototype results, they might be attributed in part to the following: There may have been less freeboard on the side of the prototype ponton under load resulting from the bending of the ponton and the slack in the connection at the stern of the pontoons. Also, the prototype raft was made up of two ponton units with the decking 21.75 ft downstream from the bow, whereas in the model the ponton units were longer and the decking located 33.6 ft downstream from the bow. Thus, the wave between the two prototype pontoons impinged on the raft superstructure, resulting in a probable build-up of the wave, whereas in the model the wave between the pontoons crested upstream from the superstructure. In addition the prototype pontoons were towed through water while in the model the pontoons remained in one position and flow at the desired velocity passed between the pontoons. Whether discrepancies between model and prototype results

exist or not, the fact that all data are on a comparable basis permits solution of the problem at hand.

Modified M4 Ponton

Description

19. The modified M4 ponton design developed had a length of 29 ft 7-5/8 in. (29.635 ft), a width of 6 ft 10-1/2 in. (6.875 ft), and a mid-section height of 3 ft 10-3/8 in. (3.865 ft) increased to 4 ft 3 in. (4.25 ft) at the bow. The bow had a sloping rake and in plan was elliptical in shape. The stern was square and provided with connections which permitted the use of additional pontoons. As tested, the modified M4 ponton unit consisted of two modified M4 pontoons plus a 21-ft-9-1/8-in. (21.760 ft) center section, making a total length of 81 ft 0-3/8 in. (81.031 ft). From the above dimensions and description it can be seen that the modified M4 ponton was similar to the standard M4 ponton, the exception being that the depth to the knuckle line of the latter was increased from 3 ft 1-1/8 in. (3.093 ft) to 3 ft 6-3/8 in. (3.531 ft).

Test results

20. Despite the extra depth of the modified M4 ponton, the ponton was loaded to freeboards of 14, 10, and 6 in. on the side in still water prior to the start of tests. Thus, a direct comparison was possible to determine the effect of the greater submerged depth. Comparative velocity-freeboard curves for the single standard M4 ponton and the modified M4 ponton are shown on plate 6. These data reveal almost identical freeboard conditions on the side of the pontoons and only slightly less freeboard on the bow of the modified M4 ponton. As a result of the

similarity of freeboard conditions, no tests were conducted with the modified M4 pontoons in rafts.

Hollow "V" Ponton

Description

21. The Hollow "V" ponton design called for a length of 31 ft 10-3/16 in. (31.849 ft), a width of 6 ft 10-1/2 in. (6.875 ft) and a mid-section height of 3 ft 10-3/8 in. (3.865 ft) increased to 4 ft 3 in. (4.25 ft) at the bow. The bow had a flat sloping rake and in plan was rather blunt (fig. 7 and plate 7). As in previous designs, the stern was square and provided with connections to permit the use of another ponton connected in tandem for heavier loads. In the case at hand an additional center section with square bow and stern was used. Thus the Hollow "V" ponton unit as tested consisted of two Hollow "V" pontoons plus a 21-ft-9-1/8-in. (21.760 ft) center section, which resulted in an overall length of 85 ft 5-1/2 in. (85.458 ft). Comparison of the Hollow "V"

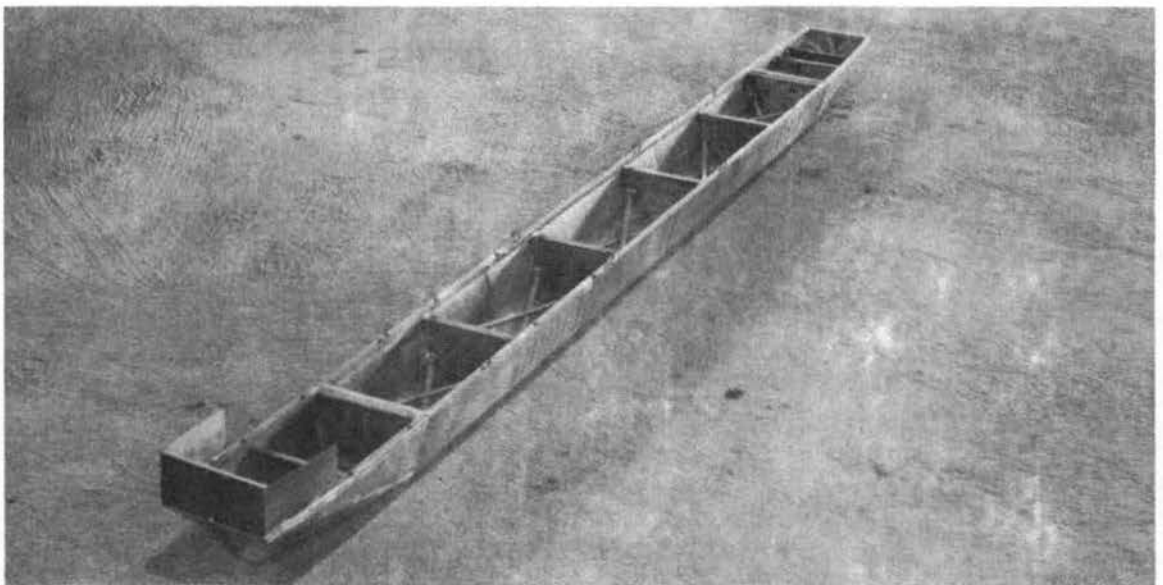

Figure 7. Hollow "V" ponton unit

ponton unit with the M4 ponton unit previously described indicates that the Hollow "V" unit was about 4 ft 5-1/8 in. (4.427 ft) longer. The length of the ponton unit was increased to secure the same displacement as the M4 ponton unit at a 2-ft-6-3/8-in. (2.531 ft) draft.

Test results

22. The results of tests with the single Hollow "V" ponton are shown in table 3, on fig. 8 and plate 7. Tests conducted with the single ponton revealed that, like the M4 ponton, the bow was the most critical point in that zero freeboard occurred first in this area. However, less freeboard existed at the bow for equivalent velocities than was observed with the M4 ponton. This is attributed to the larger frontal area of the Hollow "V" ponton.

23. Tests of the four-ponton M5 raft with the Hollow "V" pontons

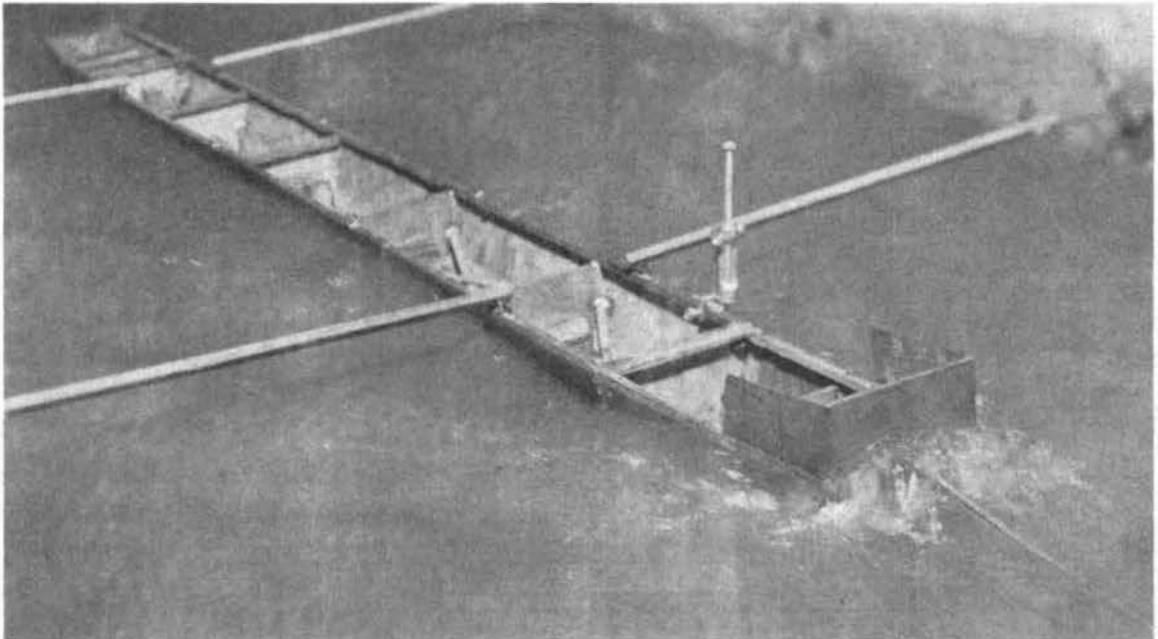

Figure 8. Flow conditions for single Hollow "V" ponton
Freeboards for velocity of 16.0 fps and 14-in. loading
Bow -9.4 in. Side 4.9 in.

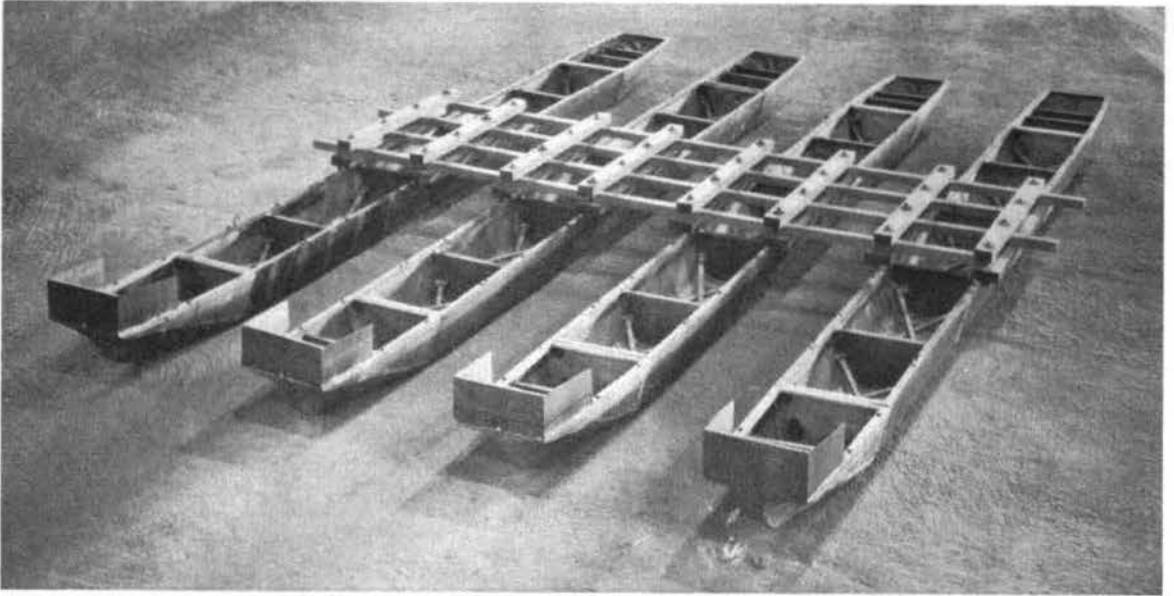

Figure 9. M5 raft with four Hollow "V" ponton units

as supports (fig. 9) revealed no improvement in freeboard conditions at the bow or sides. As in the case of the single ponton, freeboards at the bow were less with the Hollow "V" ponton than with the M4 ponton. Freeboard results on the sides of the pontoons were somewhat similar, although the wave between the pontoons appeared to be farther downstream with the Hollow "V" ponton raft (compare fig. 6 and 10). Freeboard-velocity curves at the three test loadings in still water are shown on plate 8. The location and magnitude of the average minimum freeboard on the inboard side of one of the center pontoons in the raft are shown in table 4. Average minimum freeboard curves also were developed for the inboard sides of the two outer pontoons (pontoons 1 and 4) in the raft and are presented on plate 9. Freeboards for the outboard sides of all pontoons in the raft are shown in table 5.

24. Prior to testing the seven-ponton raft with the Hollow "V" pontoons as supports (fig. 11) a check was made against the computed

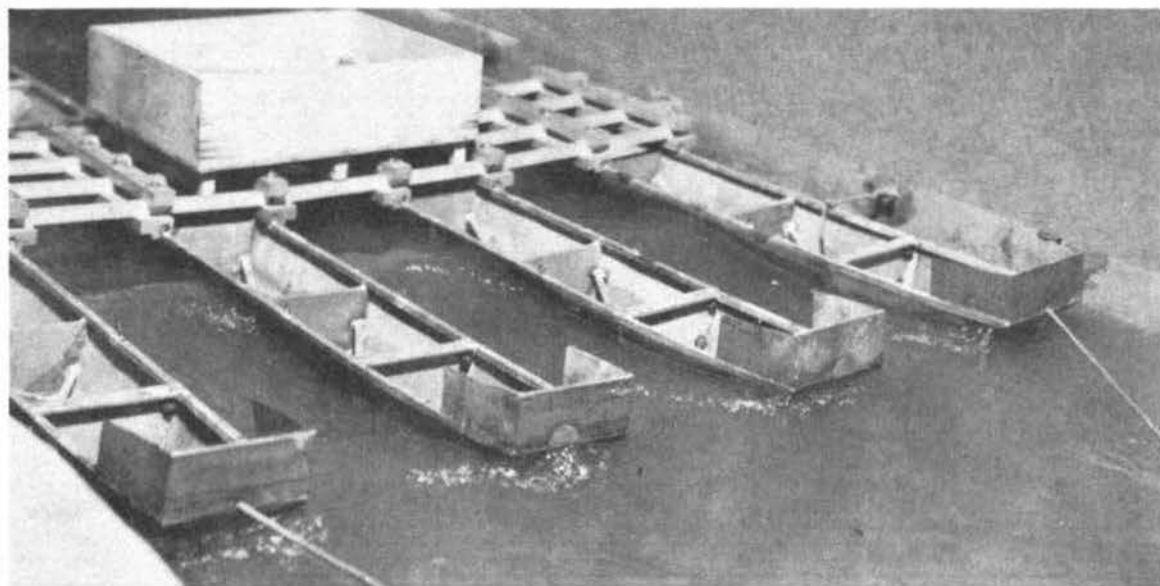

Figure 10. Flow conditions for four Hollow "V" ponton M5 raft
 Freeboards for velocity of 10.8 fps and 14-in. loading
 Ponton No. 2 bow 1.7 in. Ponton No. 2 starboard side 2.9 in.

deflection of the raft under a load of 150 tons on a base of 24 ft. A similar check was made on the four-ponton raft described in paragraph 15. Whereas close agreement between model and computed deflections obtained for the four-ponton raft, a considerable difference existed for the seven-ponton raft (see plate 9A). This variation in deflection is attributed to the extra rigidity of the raft superstructure caused by the close spacing of the pontoons and a slight discrepancy in the dead load weight of the model pontoons and raft superstructure. However, the inability of the model superstructure to reproduce the computed flexibility of the seven-ponton raft does not vitiate the model results, since the center ponton in the raft presented the most critical condition and was loaded at the start of a test to the desired freeboard.

25. In testing the seven-ponton M5 raft with the Hollow "V" pontoons as supports (fig. 11), average minimum freeboard-velocity curves were

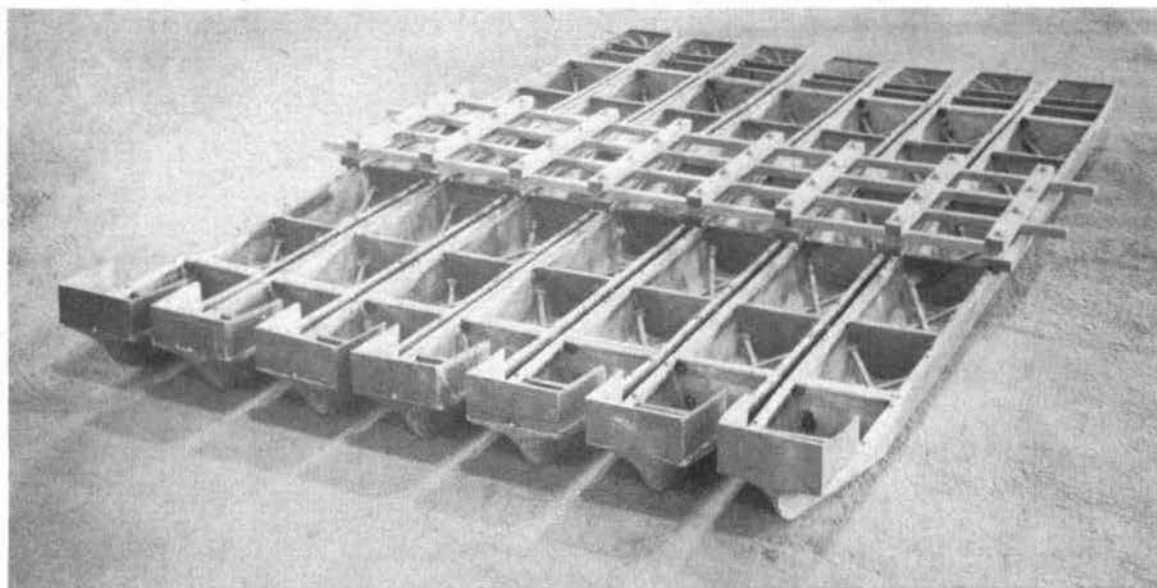

Figure 11. M5 raft with seven Hollow "V" ponton units

developed with the raft loaded in still water to produce freeboards of 14, 10, and 6 in. on the port and starboard sides of the center ponton of the raft. Tests revealed that the average minimum freeboards along the sides of the center ponton in the raft were 4.3 in. for a velocity of 12.0 ft per second and a 14-in. loading; 2.6 in. for a velocity of 10.8 ft per second and a 10-in. loading; and 2.7 in. for a velocity of 8.9 ft per second and a 6-in. loading (plate 10). Minimum freeboards on the sides for the above conditions of velocity were zero. Also, for the above-mentioned velocities and conditions of loading average minimum freeboards of -14.8, -11.0, and -10.1 in. existed on the bow. Fig. 12 shows flow conditions for the seven Hollow "V" ponton raft under a velocity of 12 ft per second and a still-water loading of 14 in. It will be noted from the test data that for all conditions of loading the bow of the center ponton was the most critical area. The location and magnitude of the average minimum freeboard on the starboard side of the center

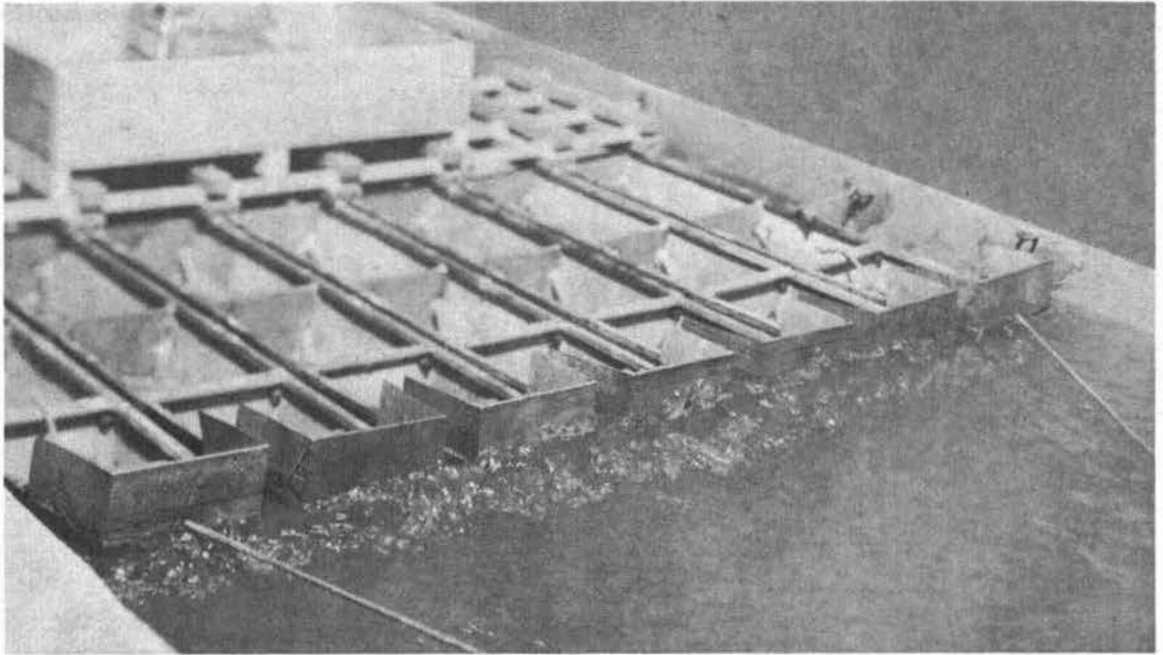

Figure 12. Flow conditions for seven Hollow "V" ponton M5 raft
 Freeboards for velocity of 12.0 fps and 14-in. loading
 Ponton No. 4 bow -14.8 in. Ponton No. 4 starboard side 4.3 in.

ponton in the seven-ponton raft are shown in table 6. Average minimum freeboard curves also were developed on the port and starboard sides of all other pontons in the raft. The freeboard data on inboard sides of the pontons are shown on plates 11-13. Freeboard data on the outboard sides of the pontons in the seven-ponton raft are shown in table 7. The freeboards for the outermost pontons of the raft are more critical than those which would have resulted if the computed deflections had been reproduced. The data have been presented, however, for comparative purposes.

Double "V" Ponton

Description

26. The Double "V" ponton had a length of 32 ft 0-5/8 in. (32.052 ft), a width of 6 ft 10-1/2 in. (6.875 ft), a midsection height of 3 ft

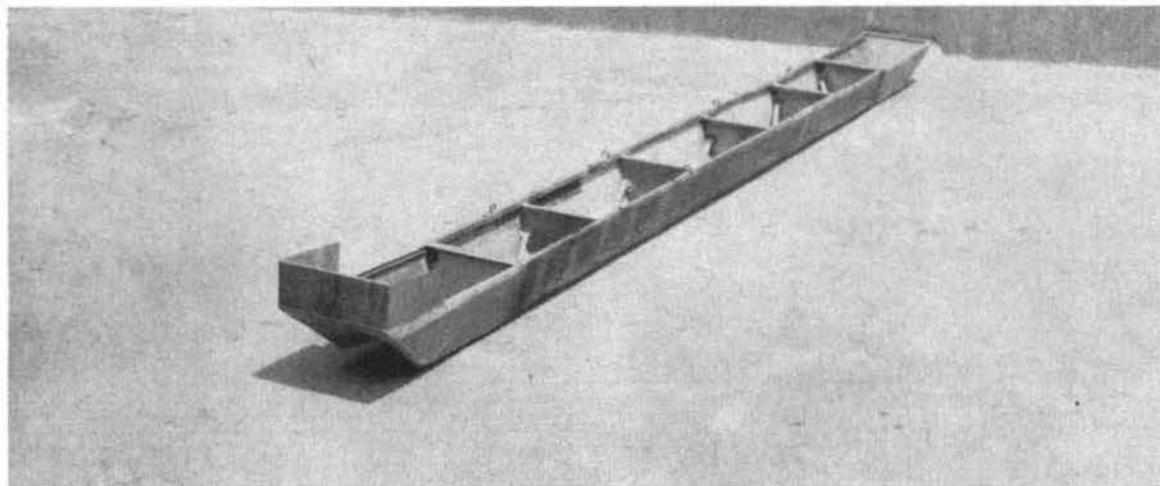

Figure 13. Double "V" ponton unit

10-3/8 in. (3.865 ft) increased to 4 ft 3 in. (4.25 ft) at the bow (fig. 13 and plate 14). The Double "V" ponton unit tested consisted of two Double "V" pontoons plus a 21-ft-9-1/8-in. (21.760 ft) center section resulting in an over-all length of 85 ft 10-3/8 in. (85.865 ft).

Test results

27. The results of tests with the single Double "V" ponton are shown in table 3, on fig. 14 and plate 14. Average minimum freeboard-velocity curves indicated that, like previous types of pontoons tested, the bow was the most critical area in that zero freeboards occurred first in this area. Average minimum freeboards on the bow and side of the Hollow "V" and Double "V" pontoons were similar for still-water loadings of 14 and 10 in. and slightly less for the Double "V" ponton under 6-in. loading. Neither type as a single ponton was an improvement over the standard M4 ponton. During testing of the Double "V" ponton as a single unit, it was noted that for a 14-in. freeboard loading and a velocity of 16.0 ft per second the ponton had a tendency to plane. This planing

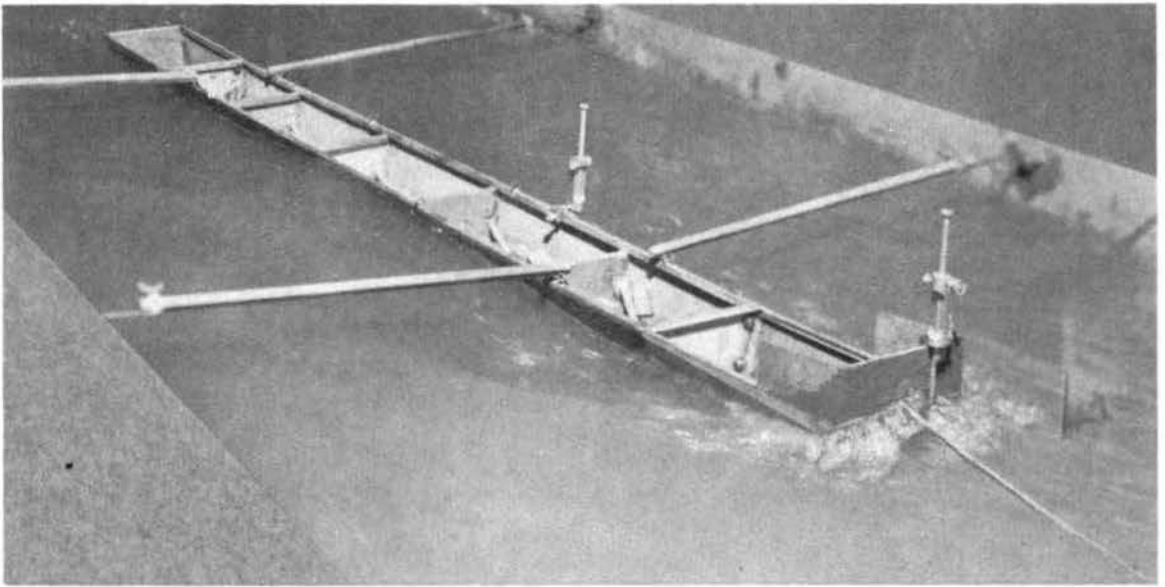

Figure 14. Flow conditions for single Double "V" ponton
 Freeboards for velocity of 16.0 fps and 14-in. loading
 Bow -3.1 in. Side 9.5 in.

action resulted in an increase of freeboard over the 14.5 ft per second velocity (last velocity before planing begins) of 1.2 in. on the side and 6.2 in. on the bow (see plate 14). This increase in freeboard is believed to result from the lifting effect of the high-velocity flow being funneled under the bow of the Double "V" ponton unit. Planing action occurred only on the single ponton with a 14-in. freeboard loading at velocities above 14.5 ft per second.

28. In testing the four-ponton M5 raft with the Double "V" ponton as supports (fig. 15), average minimum freeboard-velocity curves (plate 15) revealed that a considerable improvement in freeboard conditions was effected over the Hollow "V" ponton, especially at the bow. Freeboard conditions were about the same as observed previously with the M4 ponton raft. The wave between the pontons resulting from bow conditions was still present, although not as clearly defined as in previous tests

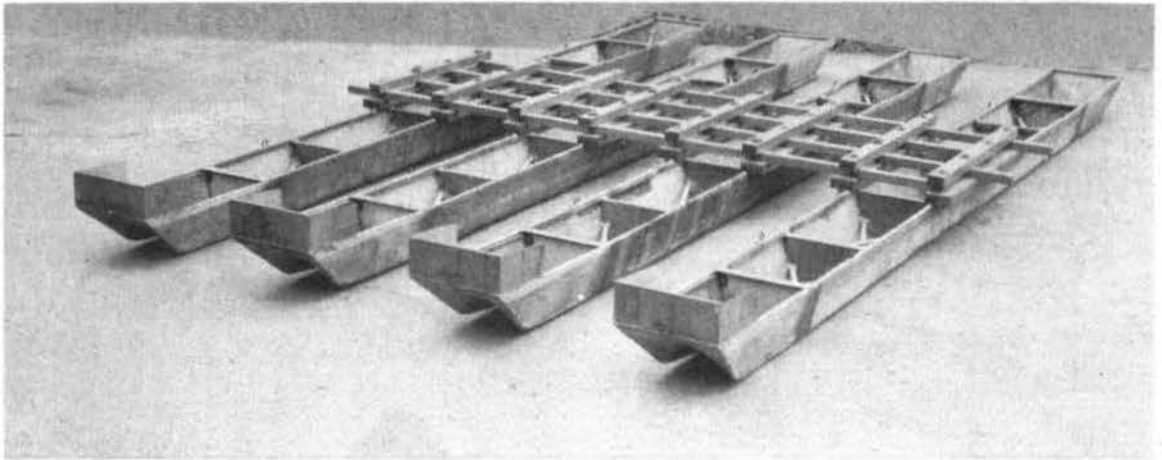

Figure 15. M5 raft with four Double "V" ponton units

(fig. 16). The location and magnitude of the average minimum freeboard on the inboard sides of the two center pontons are shown in table 4. Average minimum freeboard curves developed for the inboard sides of the two outer pontons (pontons 1 and 4) in the raft are shown on plate 16, while similar data obtained for the outboard sides of all pontons in the four-ponton raft are presented in table 8.

29. Average minimum freeboard-velocity curves developed for the seven-ponton M5 raft with the Double "V" pontons as supports (fig. 17) are shown on plate 17, while the location and magnitude of the average minimum freeboard on the port and starboard sides of the center ponton in the seven-ponton raft are shown in table 6. Results were similar to those procured with the four ponton raft in that freeboard conditions were improved both at the bow and at the sides of the pontons. Average minimum freeboard curves also were developed on the port and starboard sides of all other pontons in the raft. Freeboard data on the inboard sides of the pontons are shown on plates 18-20. Freeboard data on the outboard sides are presented in table 9. Fig. 18 shows flow conditions

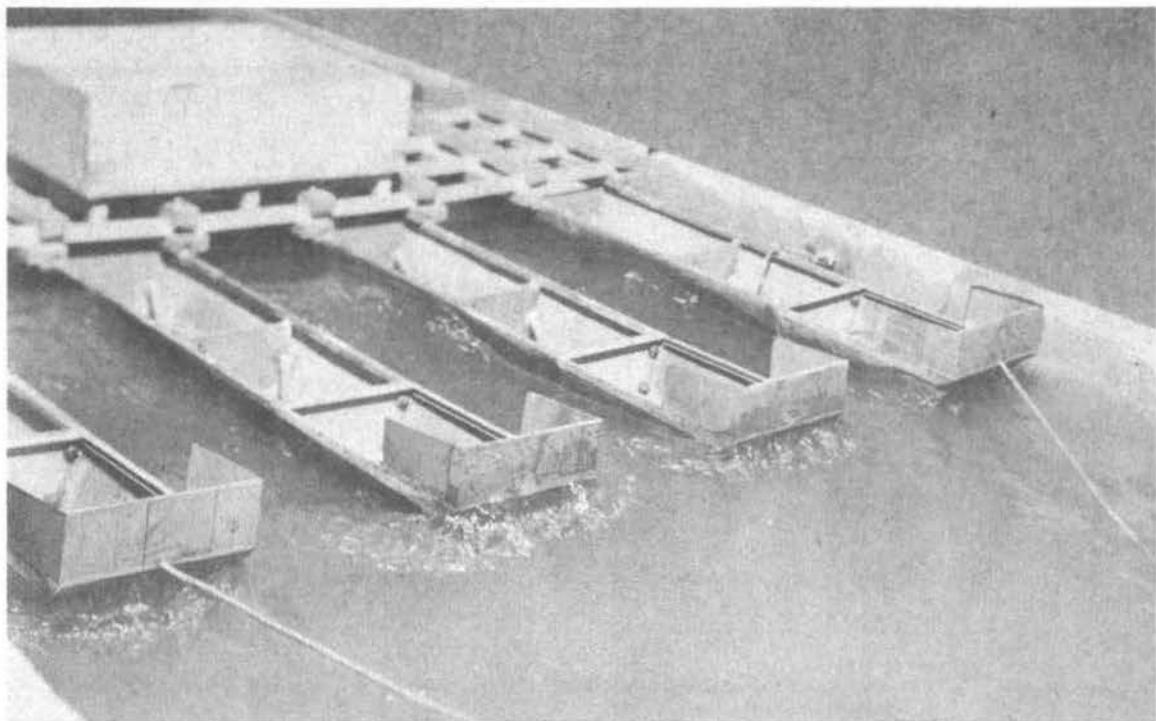

Figure 16. Flow conditions for four Double "V" ponton M5 raft
Freeboards for velocity of 11.7 fps and 14-in. loading
Ponton No. 2 bow 2.6 in. Ponton No. 2 starboard side 3.6 in.

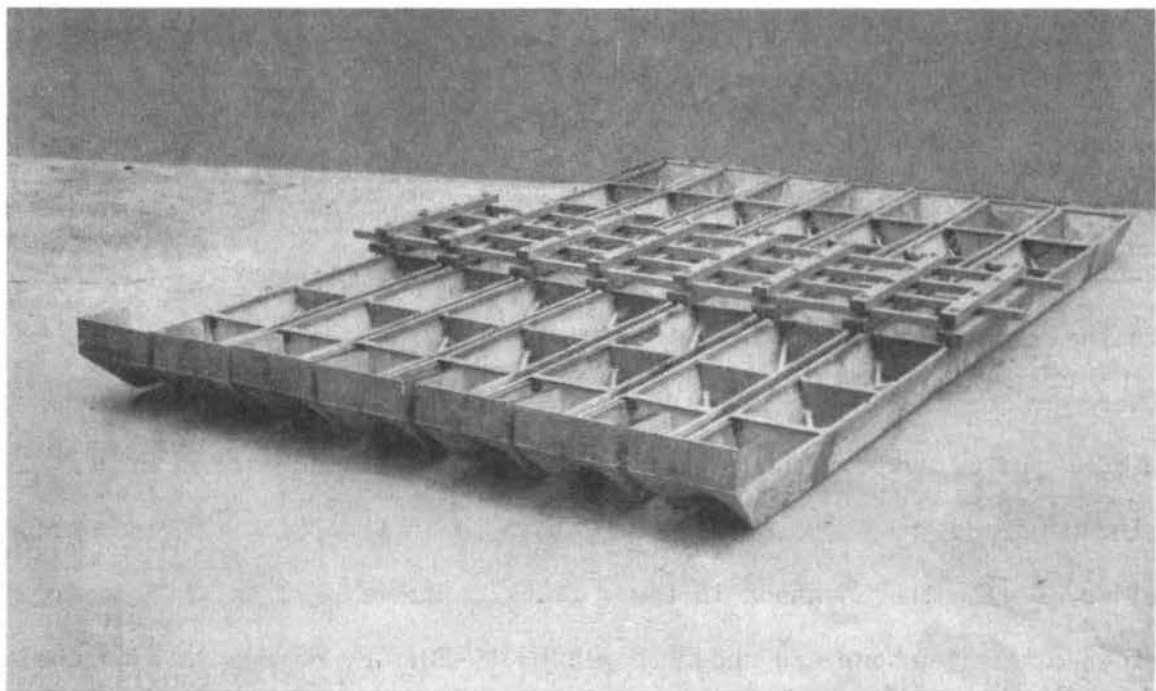

Figure 17. M5 raft with seven Double "V" ponton units

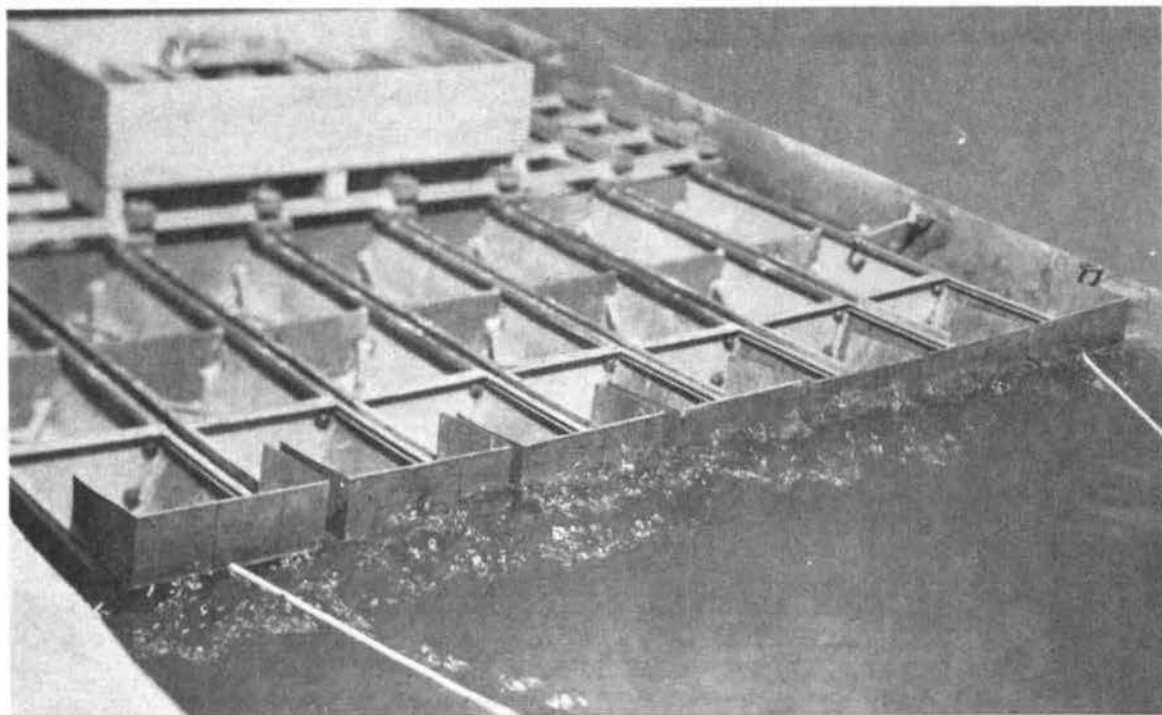

Figure 18. Flow conditions for seven Double "V" ponton M5 raft
 Freeboards for velocity of 12.0 fps and 14-in. loading
 Ponton No. 4 bow -13.9 in. Ponton No. 4 starboard side 6.3 in.

for the seven Double "V" ponton M5 raft for a velocity of 12 ft per second and a still-water loading of 14 in.

Type "A" Scow Bow Ponton

Description

30. The type "A" scow bow ponton design had a length of 31 ft 5-11/16 in. (31.474 ft), a width of 6 ft 10-1/2 in. (6.875 ft), and a mid-section height of 3 ft 10-3/8 in. (3.865 ft) increased to 4 ft 3 in. (4.25 ft) at the bow (see fig. 19 and plate 21). The bow had a flat sloping rake which intersected the bottom of the ponton at an angle of 150 degrees, and in plan was rectangular in shape. The type "A" scow bow ponton unit tested consisted of two type "A" scow bow pontons with an

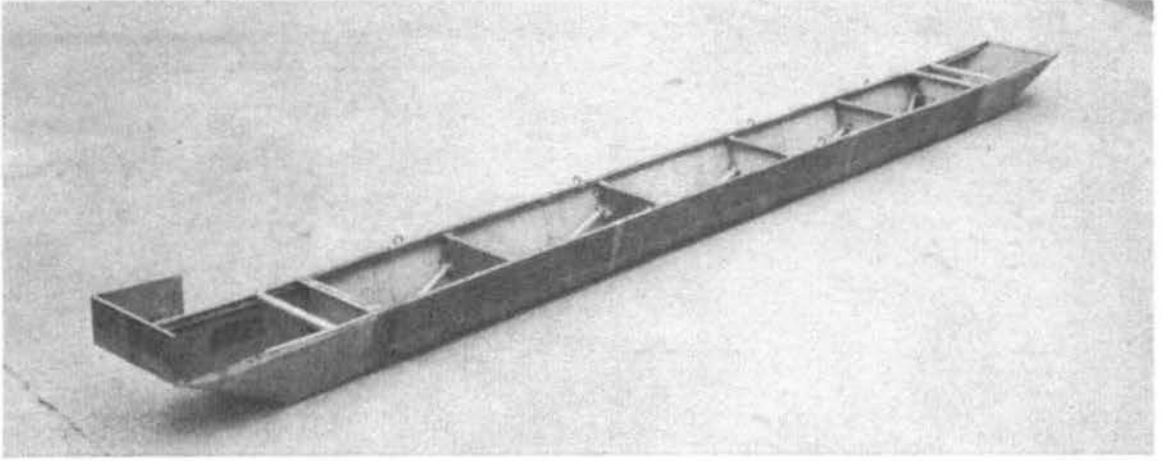

Figure 19. Type "A" scow bow ponton unit

additional 21-ft-9-1/8-in. (21.760 ft) center section, which resulted in an over-all length of 84 ft 8-1/2 in. (84.708 ft).

Test results

31. Results of tests with the single type "A" scow bow ponton are shown in table 10, on fig. 20 and plate 21. Average minimum freeboard-

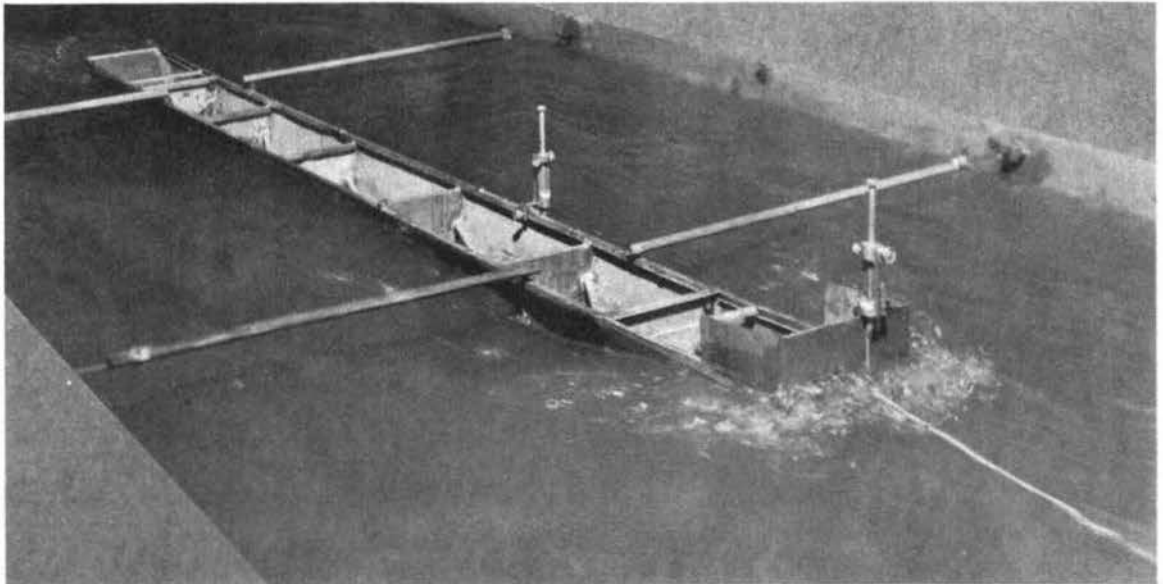

Figure 20. Flow conditions for a single type "A" scow bow ponton
 Freeboards for velocity of 16.0 fps and 14-in. loading
 Bow -13.7 in. Side 1.0 in.

velocity curves developed for the three test loadings in still water revealed results similar to those previously observed with the Hollow "V" and Double "V" type pontoons. Also, as in the case of the single Double "V" ponton, it was noted that for the 14-in. and 10-in. freeboard loadings and for flows approaching the critical velocity of 12 ft per second the ponton had a tendency to plane. This planing action is attributed to the lifting effect of the high-velocity flow against the flat sloping bow and bottom of this type ponton. Examination of plate 21 indicates a slight increase in freeboard for the 14-in. loading during planing action and a less rapid loss in freeboard for the 10-in. loading.

32. Tests of the four-ponton M5 raft with the type "A" scow bow pontoons as supports (fig. 21) revealed that the scow-type bow shape resulted in greater freeboard conditions at both bow and sides than for any of the previous ponton designs investigated. Average minimum freeboard curves developed throughout the range of velocities are shown on plate 22. Although the wave between the pontoons observed in previous tests was still present, it was definitely lower and broader than any previously observed (fig. 22). The location and magnitude of the average minimum freeboards

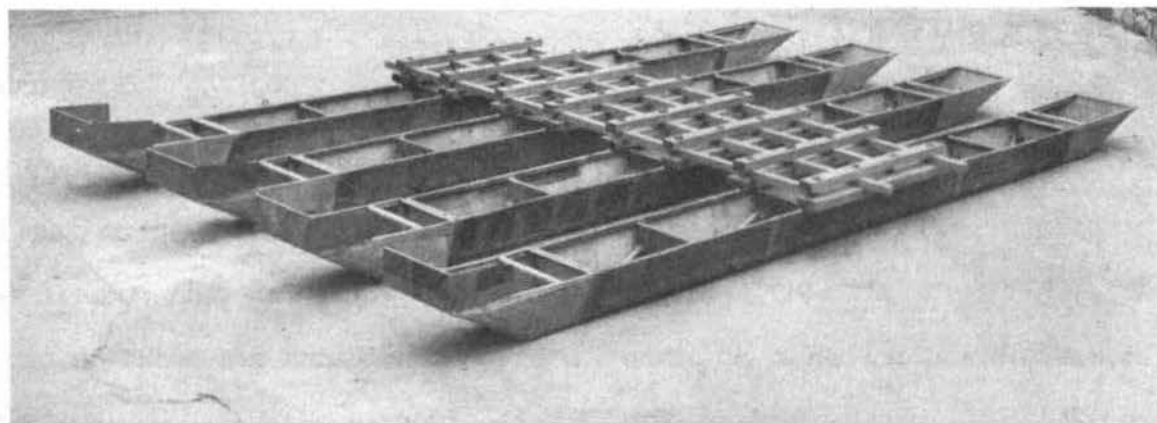

Figure 21. M5 raft with four type "A" scow bow pontoons

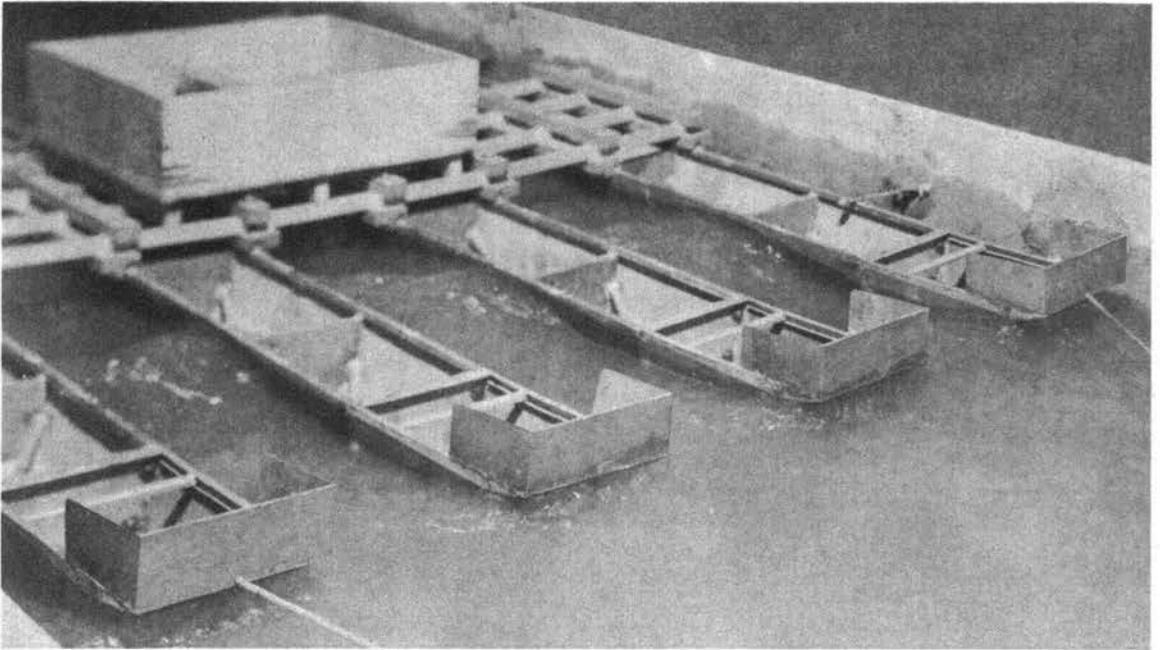

Figure 22. Flow conditions for four type "A" scow bow ponton M5 raft
 Freeboards for velocity of 11.3 fps and 14-in. loading
 Ponton No. 2 bow 4.1 in. Ponton No. 2 starboard side 3.4 in.

on the inboard side of one of the center pontoons are shown in table 11. Average minimum freeboard curves, developed for the inboard sides of the two outer pontoons (pontoons 1 and 4), are shown on plate 23. The average minimum freeboards for the outboard sides of all pontoons in the raft may be found in table 12.

33. Tests of the seven-ponton M5 raft with the type "A" scow bow ponton as supports (fig. 23) resulted in freeboard conditions about the same as those recorded with the seven Double "V" ponton raft. Although freeboard conditions at the bow were slightly better with the scow bow shape, they were slightly worse on the sides. Average minimum freeboard-velocity curves are shown on plate 24. Flow conditions are shown on fig. 24. The location and magnitude of the average minimum freeboard on the port and starboard sides of the center ponton in the seven-ponton

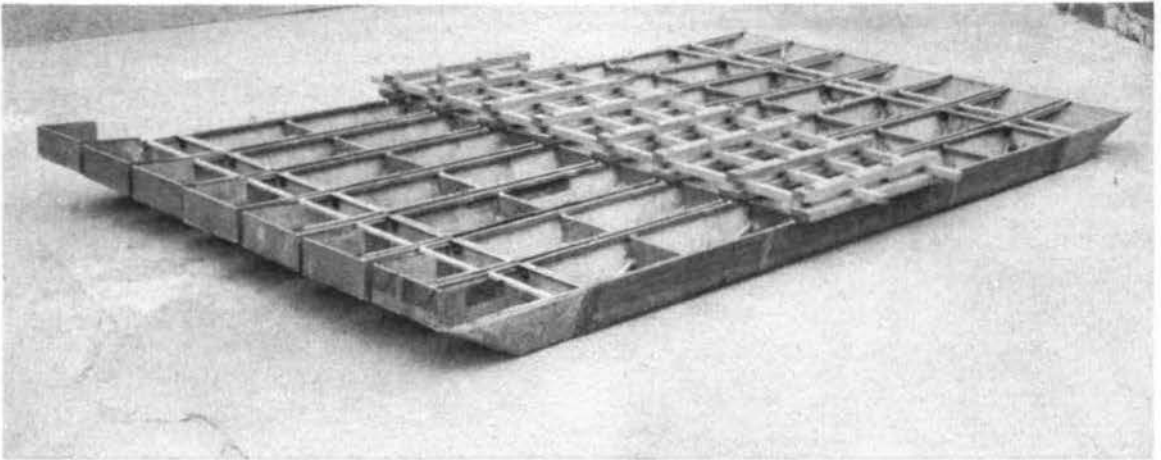

Figure 23. M5 raft with seven type "A" scow bow ponton units

raft are shown in table 13. Average minimum freeboard curves were also developed on the port and starboard sides of all other pontoons in the raft. Freeboard data on the inboard sides of the pontoons are shown on plates 25-27. Freeboard data on the outboard sides of the pontoons in the seven-ponton raft are shown in table 14.

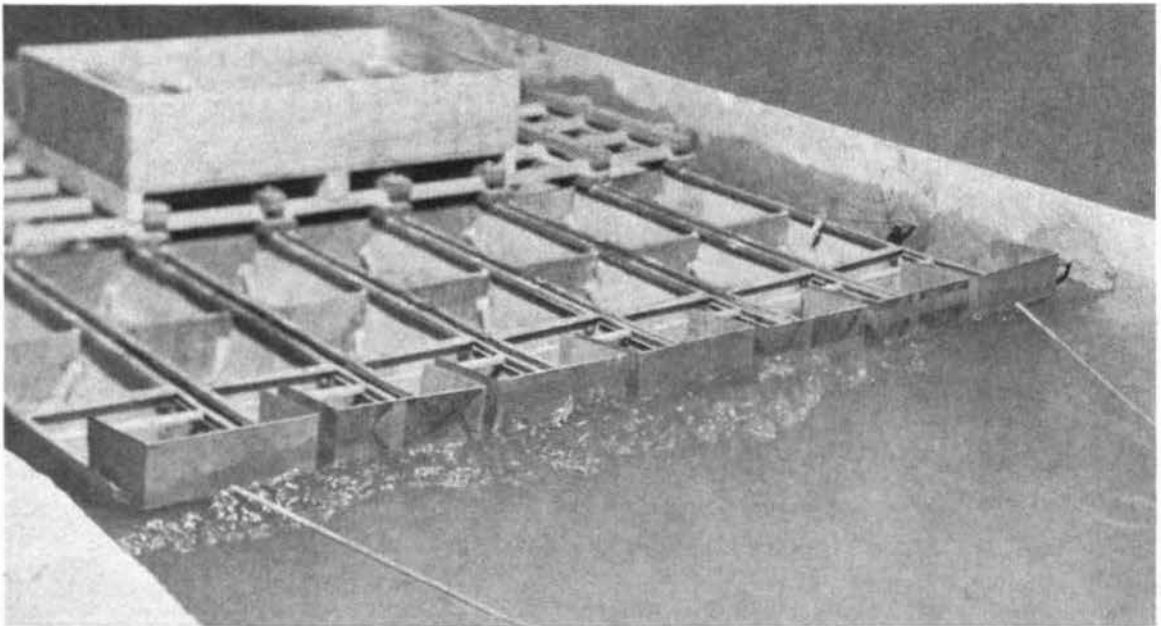

Figure 24. Flow conditions for seven type "A" scow bow ponton M5 raft
 Freeboards for velocity of 12.0 fps and 14-in. loading
 Ponton No. 4 bow -12.5 in. Ponton No. 4 starboard side 5.6 in.

Type "B" Scow Bow PontonDescription

34. The type "B" scow bow ponton design had a length of 31 ft 8-7/16 in. (31.703 ft), a width of 6 ft 10-1/2 in. (6.875 ft), a midsection height of 3 ft 10-3/8 in. (3.865 ft) increased to 4 ft 3 in. (4.25 ft) at the bow (see fig. 25). From the above dimensions and a comparison of plates 21 and 28 it will be noted that the type "A" and "B" scow bow pontons were somewhat similar in design. The exceptions were that the type "A" ponton was shorter in length by 5-1/2 in. and that the rake of the bow intersected the bottom of the ponton at an angle rather than on an 8-ft radius as in the case of the type "B" ponton. The type "B" scow bow ponton unit tested consisted of two type "B" pontons plus a 21-ft-9-1/8-in. (21.760 ft) center section, resulting in an over-all length of 85 ft 2 in. (85.166 ft).

Test results

35. Results of tests with the single type "B" scow bow ponton are

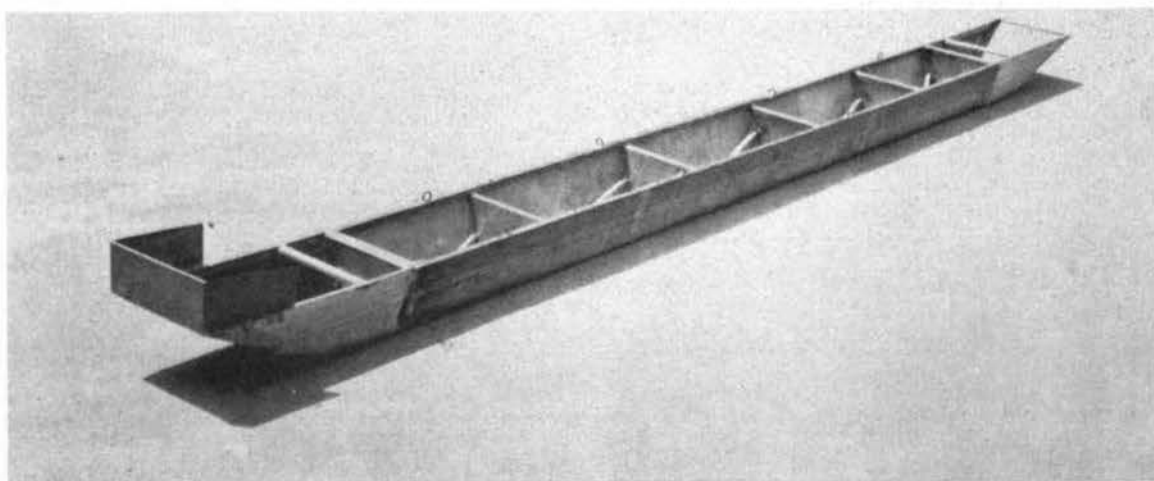

Figure 25. Type "B" scow bow ponton unit

shown in table 10, on fig. 26, and on plate 28. Average minimum freeboard-velocity curves developed for the bow and sides of a single ponton (plate 28) reveal a slight increase in freeboards at the bow over those observed with the type "A" scow bow. Little difference was noted in side freeboards. Flow past a single ponton is shown on fig. 26. As in the case of the type "A" scow bow ponton unit, planing action was observed on the type "B" scow bow ponton unit for velocities in excess of 12 ft per second. This planing action resulted in a slight gain in freeboard for the 14-in. loading and a less rapid loss in freeboard for the 10- and 6-in. loadings.

36. Average minimum freeboard-velocity data procured with the four-ponton M5 raft and the type "B" scow bow pontoons as supports (fig. 27 and plate 29) were similar to the data procured with the type "A" scow bow ponton. Flow conditions (fig. 28) are also comparable. The location and magnitude of the average minimum freeboard on the inboard side of one of

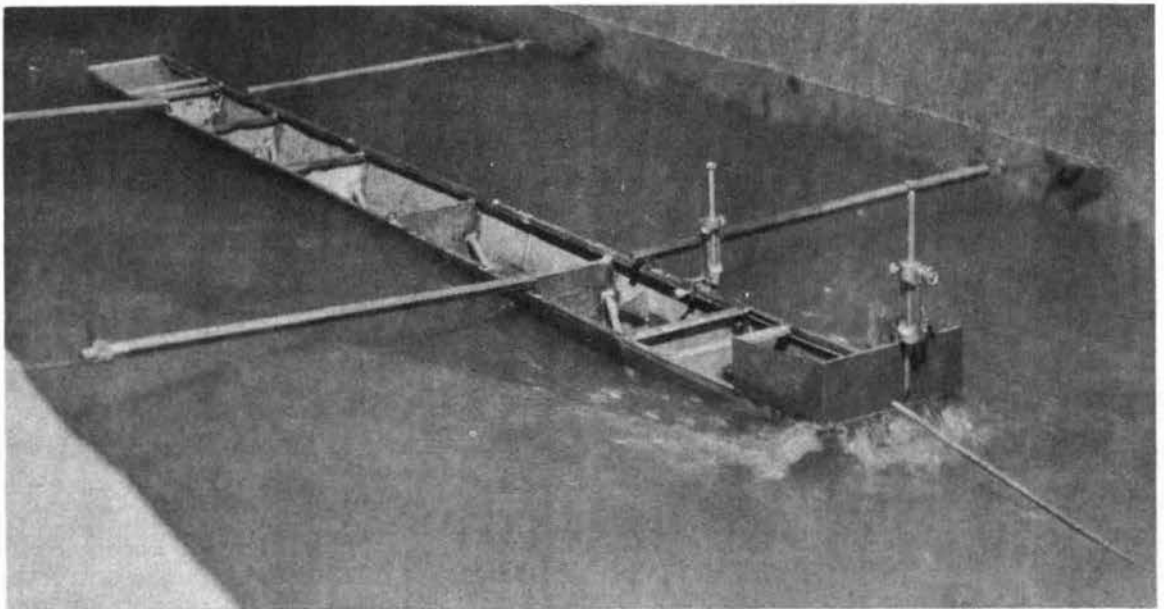

Figure 26. Flow conditions for single type "B" scow bow ponton
 Freeboards for velocity of 16.0 fps and 14-in. loading
 Bow -14 in. Side 1.25 in.

the two center pontoons are shown in table 11. Average minimum freeboard curves, developed for the inboard sides of the two outer pontoons (pontoons 1 and 4) in the raft, are shown on plate 30. Average minimum freeboards obtained for the outboard sides of all pontoons in the four-pontoon raft are given in table 15.

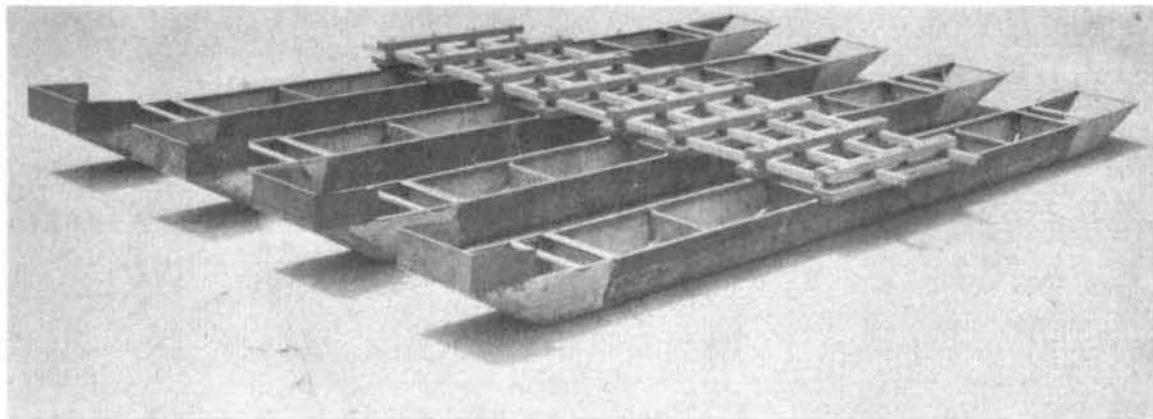

Figure 27. M5 raft with four type "B" scow bow ponton units

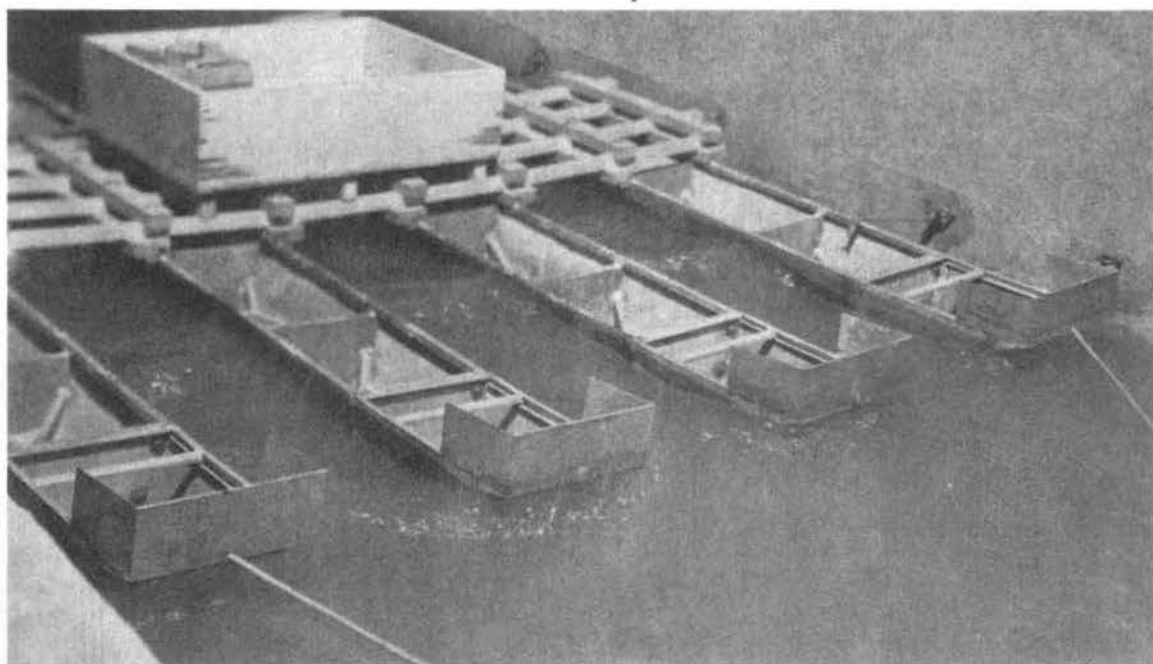

Figure 28. Flow conditions for four type "B" scow bow ponton M5 raft
 Freeboards for velocity of 10.8 fps and 14-in. loading
 Ponton No. 2 bow 4.0 in. Ponton No. 2 starboard side 3.3 in.

37. Average minimum freeboard-velocity curves (plate 31) developed with the seven-ponton M5 raft and the type "B" scow bow pontons as supports (fig. 29) revealed side freeboard results about similar to those recorded with the type "A" scow bow. Freeboards at the bow of the type "B" scow bow ponton appeared slightly greater at still-water loadings of 14 and 10 in. than those observed with the type "B" scow bow ponton. Flow conditions (fig. 30) were still most critical at the bow. The location and magnitude of the average minimum freeboard on the port and starboard sides of the center ponton in the seven-ponton raft are shown in table 13. Average minimum freeboard curves also were developed on the port and starboard sides of all the other pontons in the raft. Freeboard data on the inboard sides of the pontons are shown on plates 32-34. Freeboard data on the outboard sides are presented in table 16.

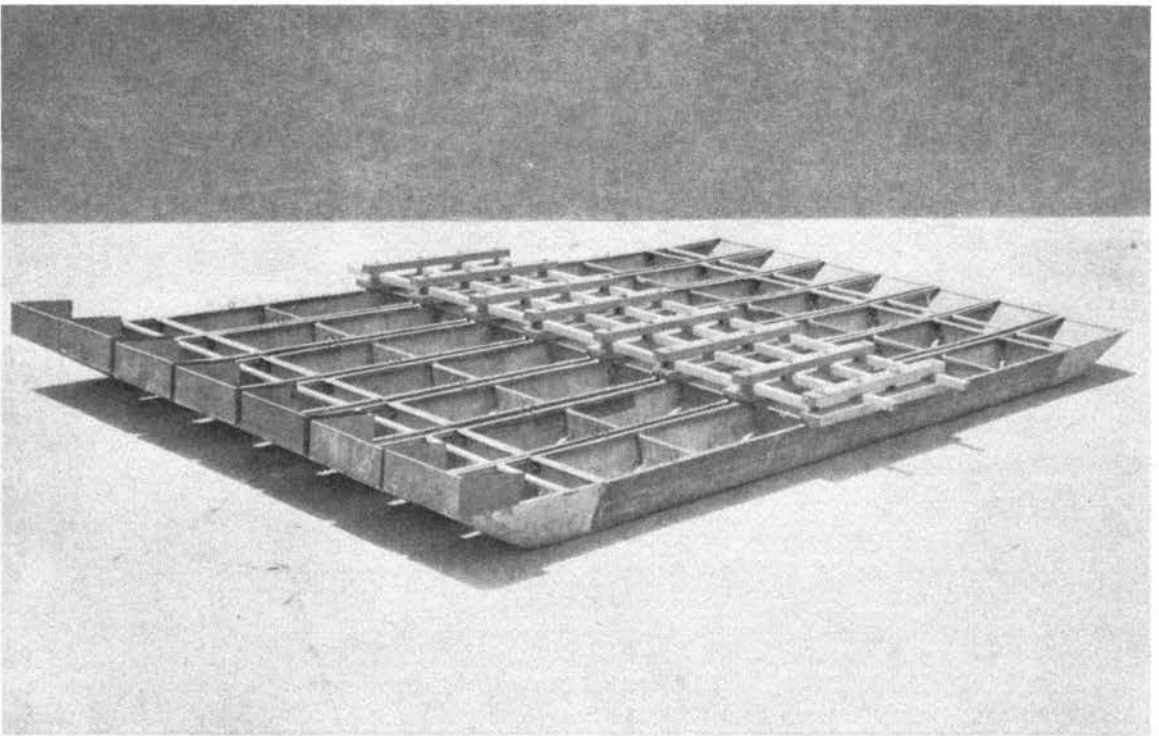

Figure 29. M5 raft with seven type "B" scow bow ponton units

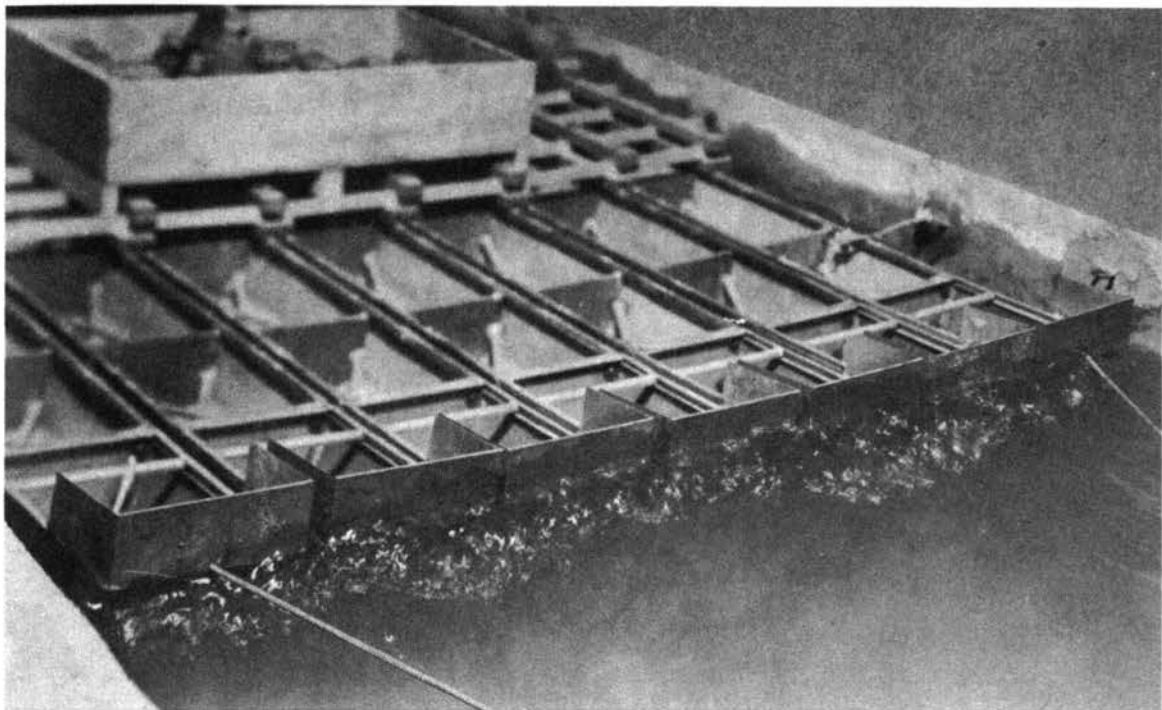

Figure 30. Flow conditions for seven type "B" scow bow ponton M5 raft
Freeboards for velocity of 12.0 fps and 14-in. loading
Ponton No. 4 bow -13.5 in. Ponton No. 4 starboard side 7.0 in.

PART IV: DISCUSSION OF TEST RESULTS

38. Although tests of the standard M4 ponton unit revealed satisfactory performance as a single ponton, its performance in the four-ponton raft confirmed previous prototype observations of unsatisfactory conditions. The waves created by flow passing the ponton bows crested between the pontoons with a considerable loss of freeboard on the side. Improved freeboard conditions were secured with several of the other types of ponton bows investigated wherein the bow had a flatter rake and presented more frontal area to the path of flow.

39. Presented in tables 17-23 are detailed comparisons of the average minimum freeboards for the M4, Hollow "V", Double "V", and the types "A" and "B" scow bow pontoons as single floating units and as supports for the four- and seven-ponton rafts. As a single ponton the M4 type provided best freeboard conditions both at the bow and on the side; the other types of single pontoons investigated were about equal in performance, although inferior to the M4 single ponton.

40. The four-ponton raft created the most critical freeboard conditions on the side. For low velocities, freeboard conditions at the bow and on the sides of the pontoons in the raft were similar. However, as the velocity of flow increased the superiority of the types "A" and "B" scow bows and the Double "V" pontoons was demonstrated by the ability of these pontoons to operate in high-velocity flows with a less rapid loss of freeboard on the bow and sides than was evidenced by the M4 or Hollow "V" type pontoons. The types "A" and "B" scow bow pontoons were superior in performance to the Double "V" type ponton. The superiority of the

types "A" and "B" scow bow shapes is attributed to the flat rake of bow and broad frontal area which caused flow striking the bow to be forced under the ponton rather than to the sides where the adjacent pontons restricted flow to such a degree that the flow built up between the pontons causing the rapid loss of freeboard observed with the M4 and Hollow "V" type pontons.

41. In comparing the performance of the ponton units in the seven-ponton raft, no data were procured on the M4 ponton raft, as the performance with the four-ponton raft had indicated that revisions to the bow shape were necessary. The performance of the types "A" and "B" scow bow pontons and the Double "V" and Hollow "V" pontons in the seven-ponton raft was similar to that observed with the four-ponton raft, in that best freeboard conditions resulted with the types "A" or "B" scow bow shapes. Unlike the results of tests with the four-ponton raft, however, the use of the seven-ponton raft caused freeboard at the bow to be more critical than on the sides. This is attributed to the small space remaining between the pontons of the reinforced raft and the large frontal area presented to flow by the ponton bows.

42. Of the five types of ponton bow shapes investigated, best all-around performance was observed with the types "A" and "B" scow bow shapes; the type "B" scow bow with the rounded transition from bow to the bottom of the ponton was slightly superior to the type "A" scow bow shape. The types "A" and "B" scow bow shapes have the added advantage that the simplicity of lines should make them more economical to construct.

TABLES

TABLE 1

LOCATION AND MAGNITUDE OF AVERAGE MINIMUM FREEBOARD ON SIDE OF PONTONS

14-Inch Freeboard Loading on Side in Still Water

Single M4 Ponton Unit			M5 Raft with Four M4 Ponton Units*		
Velocity Ft/Sec	Distance from Bow on Side in Feet	Observed Average Freeboard in Inches	Velocity Ft/Sec	Distance from Bow on Side in Feet	Observed Average Freeboard in Inches
1.6	12.0	14.00	1.6	12.0	14.00
3.2	12.0	13.90	3.2	12.0	13.90
5.1	12.0	13.70	5.1	12.0	13.60
7.0	12.0	13.25	7.0	13.5	13.00
8.9	15.0	11.90	8.9	18.5	10.75
10.8	19.5	10.50	10.8	21.0	5.50
12.5	22.5	8.75			
13.9	25.5	7.25			
16.0	27.0	4.85			
10-Inch Freeboard Loading on Side in Still Water					
1.6	12.0	10.00	1.6	12.0	10.00
3.2	12.0	9.85	3.2	12.0	9.90
5.1	12.0	9.45	5.1	12.0	9.50
7.0	12.0	8.75	7.0	15.0	8.10
8.9	16.5	7.15	8.9	18.0	4.60
10.8	21.0	4.70			
12.5	24.0	2.75			
6-Inch Freeboard Loading on Side in Still Water					
1.6	12.0	5.95	1.6	12.0	6.00
3.2	12.0	5.70	3.2	12.0	5.85
5.1	12.0	5.20	5.1	15.0	5.60
7.0	21.0	4.45	7.0	24.0	4.85
8.9	24.0	2.15	7.7	27.0	3.40

* The freeboard data for the M5 raft are the average minimum freeboards measured on the starboard side of ponton No. 2.

TABLE 2

AVERAGE MINIMUM FREEBOARDS ON OUTBOARD SIDES
OF M4 PONTONS IN THE 4-PONTON M5 RAFT

Velocity Ft/Sec	M5 Raft Loaded to 14-Inch Freeboard in Still Water *				M5 Raft Loaded to 10-Inch Freeboard in Still Water *				M5 Raft Loaded to 6-Inch Freeboard in Still Water *			
	Ponton No. 1 Port Side	Ponton No. 2 Port Side	Ponton No. 3 Starboard Side	Ponton No. 4 Starboard Side	Ponton No. 1 Port Side	Ponton No. 2 Port Side	Ponton No. 3 Starboard Side	Ponton No. 4 Starboard Side	Ponton No. 1 Port Side	Ponton No. 2 Port Side	Ponton No. 3 Starboard Side	Ponton No. 4 Starboard Side
1.6	22.1	14.2	14.2	22.5	18.3	10.0	9.8	18.5	17.5	6.6	6.5	17.1
3.2	21.7	14.0	13.9	22.1	18.2	9.9	9.7	18.4	17.2	6.5	6.1	17.0
5.1	21.2	13.7	13.5	21.7	17.8	9.8	9.5	18.0	17.0	6.3	5.8	16.8
7.0	19.4	13.0	13.1	21.1	16.7	8.6	7.9	17.0	16.4	5.9	5.4	16.5
7.7									15.6	4.7	4.2	15.6
8.9	17.5	10.8	11.2	20.0	14.6	5.0	4.9	14.9				
10.8	13.3	5.9	6.0	14.5								

* Prior to conducting tests pontoons numbers 2 and 3 in the M5 raft were loaded in still water to 14-, 10-, and 6-in. freeboards on the starboard and port sides, respectively.
All freeboard measurements are in prototype inches.

TABLE 3

LOCATION AND MAGNITUDE OF AVERAGE MINIMUM FREEBOARD ON SIDE OF PONTONS

14-Inch Freeboard Loading on Side in Still Water

Hollow "V" Ponton Unit			Double "v" Ponton Unit		
Velocity Ft/Sec	Distance from Bow on Side in Feet	Observed Average Freeboard in Inches	Velocity Ft/Sec	Distance from Bow on Side in Feet	Observed Average Freeboard in Inches
1.6	15.0	14.00	1.6	13.5	14.00
3.2	15.0	13.90	3.2	13.5	13.90
5.1	15.0	13.70	5.1	13.5	13.50
7.0	15.0	13.30	7.0	16.0	12.80
8.9	16.5	12.20	8.9	18.0	11.50
10.8	21.0	10.60	10.8	18.0	10.80
12.5	27.0	9.00	12.5	25.5	9.40
15.2	33.0	6.80	14.5	42.0	8.30
16.0	36.0	4.90	16.0	46.0	9.50
10-Inch Freeboard Loading on Side in Still Water					
1.6	15.0	10.00	1.6	13.5	10.00
3.2	15.0	9.90	3.2	13.5	9.90
5.1	15.0	9.70	5.1	13.5	9.70
7.0	16.5	9.40	7.0	16.5	9.00
8.9	19.5	8.10	8.9	18.5	7.40
10.8	21.0	6.10	10.8	21.0	5.20
13.5	25.0	2.50	13.5	33.0	3.40
6-Inch Freeboard Loading on Side in Still Water					
1.6	15.0	6.00	1.6	13.5	6.00
3.2	15.0	5.80	3.2	13.5	5.80
5.1	15.0	5.60	5.1	18.0	5.40
7.0	16.5	5.20	7.0	19.5	4.50
8.9	19.0	4.30	8.9	13.5	2.30
10.8	22.5	2.20			

TABLE 4

LOCATION AND MAGNITUDE OF AVERAGE MINIMUM FREEBOARD ON SIDE OF PONTONS

14-Inch Freeboard Loading on Side in Still Water

M5 Raft with Four Hollow "Y" Ponton Units*			M5 Raft with Four Double "Y" Ponton Units*		
Velocity Ft/Sec	Distance from Bow on Side in Feet	Observed Average Freeboard in Inches	Velocity Ft/Sec	Distance from Bow on Side in Feet	Observed Average Freeboard in Inches
1.6	15.0	14.00	1.6	13.5	14.00
3.2	15.0	13.90	3.2	13.5	13.90
5.1	15.0	13.70	5.1	16.5	13.70
7.0	18.0	12.80	7.0	21.0	12.60
8.9	22.5	8.80	8.9	21.0	10.60
10.8	27.0	2.90	11.7	25.5	3.60
10-Inch Freeboard Loading on Side in Still Water					
1.6	15.0	10.00	1.6	13.5	10.00
3.2	15.0	9.90	3.2	13.5	9.90
5.1	16.5	9.70	5.1	16.5	9.70
7.0	18.0	9.20	7.0	21.0	7.90
8.9	22.5	5.90			
9.8	24.0	3.20	9.8	19.5	3.40
6-Inch Freeboard Loading on Side in Still Water					
1.6	12.0	6.00	1.6	13.5	6.00
3.2	12.0	5.80	3.2	15.0	5.80
5.1	15.0	5.30	5.1	16.5	5.40
7.0	19.0	4.70	7.0	19.5	4.10
8.6	22.5	1.60	8.1	16.5	2.20

* The freeboard data for the M5 raft are the average minimum freeboards measured on the starboard side of ponton No. 2.

TABLE 5

AVERAGE MINIMUM FREEBOARDS ON OUTBOARD SIDES
OF HOLLOW "V" PONTONS IN THE 4-PONTON M5 RAFT

Velocity Ft/Sec	M5 Raft Loaded to 14-Inch Freeboard in Still Water*				M5 Raft Loaded to 10-Inch Freeboard in Still Water*				M5 Raft Loaded to 6-Inch Freeboard in Still Water*			
	Ponton No. 1 Port Side	Ponton No. 2 Port Side	Ponton No. 3 Starboard Side	Ponton No. 4 Starboard Side	Ponton No. 1 Port Side	Ponton No. 2 Port Side	Ponton No. 3 Starboard Side	Ponton No. 4 Starboard Side	Ponton No. 1 Port Side	Ponton No. 2 Port Side	Ponton No. 3 Starboard Side	Ponton No. 4 Starboard Side
1.6	26.6	16.7	17.5	26.6	25.6	13.3	13.5	24.8	22.3	9.4	9.4	22.0
3.2	26.4	16.6	17.3	26.4	25.4	13.1	13.4	24.6	22.3	9.2	9.2	22.0
5.1	26.2	16.2	17.1	26.2	25.2	13.0	13.1	24.4	21.9	8.8	9.0	21.8
7.0	25.7	15.7	16.6	25.3	24.7	12.4	12.4	23.9	21.2	8.3	8.3	20.7
8.6									20.7	5.8	7.1	17.1
8.9	22.5	10.3	12.5	21.9	22.0	9.9	9.4	21.2				
9.8					18.2	9.0	9.7	18.5				
10.8	18.5	6.1	7.2	16.3								

* Prior to conducting tests pontons numbers 2 and 3 in the M5 raft were loaded in still water to 14-, 10-, and 6-in. freeboards on the starboard and port sides, respectively. All freeboard measurements are in prototype inches.

TABLE 6

LOCATION AND MAGNITUDE OF AVERAGE MINIMUM FREEBOARD ON SIDE OF PONTONS

14-Inch Freeboard Loading on Side in Still Water

M5 Raft with Seven Hollow "V" Ponton Units*			M5 Raft with Seven Double "V" Ponton Units*		
Velocity Ft/Sec	Distance from Bow on Side in Feet	Observed Average Freeboard in Inches	Velocity Ft/Sec	Distance from Bow on Side in Feet	Observed Average Freeboard in Inches
1.6	16.5	14.00	1.6	15.0	14.00
3.2	16.5	13.90	3.2	15.0	13.90
5.1	16.5	13.50	5.1	16.5	13.20
7.0	16.5	12.40	7.0	18.5	12.40
8.9	18.0	10.40	8.9	21.0	10.80
10.8	18.0	7.60	10.8	23.0	8.80
12.0	21.0	4.30	12.0	26.5	6.30
10-Inch Freeboard Loading on Side in Still Water					
1.6	13.5	10.00	1.6	13.5	10.00
3.2	13.5	9.70	3.2	13.5	9.90
5.1	15.0	9.40	5.1	21.5	9.70
7.0	18.0	8.30	7.0	25.5	9.20
8.9	18.5	5.60	8.9	25.5	7.70
10.8	19.5	2.50	10.8	24.0	5.00
6-Inch Freeboard Loading on Side in Still Water					
1.6	15.0	6.00	1.6	13.5	6.00
3.2	15.0	5.60	3.2	13.5	5.80
5.1	16.5	5.00	5.1	22.5	5.20
7.0	18.0	4.10	7.0	27.5	4.10
8.9	18.5	2.90	9.8	13.5	2.20

* The freeboard data for the M5 raft are the average minimum freeboards measured on starboard side of ponton No. 4.

TABLE 7

AVERAGE MINIMUM FREEBOARDS ON OUTBOARD SIDES
OF HOLLOW "V" PONTONS IN THE 7-PONTON M5 RAFT

Velocity Ft/Sec	M5 Raft Loaded to 14-Inch Freeboard in Still Water*						M5 Raft Loaded to 10-Inch Freeboard in Still Water*						M5 Raft Loaded to 6-Inch Freeboard in Still Water*					
	Ponton No. 1 Port Side	Ponton No. 2 Port Side	Ponton No. 3 Port Side	Ponton No. 5 Starboard Side	Ponton No. 6 Starboard Side	Ponton No. 7 Starboard Side	Ponton No. 1 Port Side	Ponton No. 2 Port Side	Ponton No. 3 Port Side	Ponton No. 5 Starboard Side	Ponton No. 6 Starboard Side	Ponton No. 7 Starboard Side	Ponton No. 1 Port Side	Ponton No. 2 Port Side	Ponton No. 3 Port Side	Ponton No. 5 Starboard Side	Ponton No. 6 Starboard Side	Ponton No. 7 Starboard Side
1.6	24.3	19.1	15.7	16.0	19.4	24.7	21.4	15.7	11.3	11.5	15.1	20.7	18.5	11.2	6.5	8.6	12.2	18.9
3.2	24.1	18.9	15.5	15.8	19.2	24.5	21.2	15.5	11.3	11.3	14.9	20.5	18.1	11.0	6.5	8.4	12.2	18.7
5.1	23.9	18.4	15.0	15.1	19.0	24.2	20.9	15.3	10.8	10.8	14.4	20.2	17.6	10.8	5.4	7.6	11.5	18.4
7.0	23.2	17.7	13.9	14.0	17.8	23.1	20.0	13.9	9.7	9.7	13.5	19.3	15.8	9.8	4.3	6.0	10.0	17.2
8.9	21.7	15.9	13.7	12.2	14.5	21.4	18.0	12.1	7.9	8.1	11.7	16.9	14.2	7.6	3.1	3.7	8.6	15.3
10.8	16.9	13.3	9.9	9.9	13.6	16.6	14.4	9.2	3.9	4.1	7.7	14.0						
12.0	13.3	11.5	7.6	7.5	10.9	13.2												

* Prior to conducting tests ponton No. 4 in the M5 raft was loaded in still water to 14-, 10-, and 6-in. freeboards on the starboard and port sides, respectively. All freeboard measurements are in prototype inches.

TABLE 8

AVERAGE MINIMUM FREEBOARDS ON OUTBOARD SIDES
OF DOUBLE "V" PONTONS IN THE 4-PONTON M5 RAFT

Velocity Ft/Sec	M5 Raft Loaded to 14-Inch Freeboard in Still Water*				M5 Raft Loaded to 10-Inch Freeboard in Still Water*				M5 Raft Loaded to 6-Inch Freeboard in Still Water*			
	Ponton No. 1 Port Side	Ponton No. 2 Port Side	Ponton No. 3 Starboard Side	Ponton No. 4 Starboard Side	Ponton No. 1 Port Side	Ponton No. 2 Port Side	Ponton No. 3 Starboard Side	Ponton No. 4 Starboard Side	Ponton No. 1 Port Side	Ponton No. 2 Port Side	Ponton No. 3 Starboard Side	Ponton No. 4 Starboard Side
1.6	26.6	16.7	15.7	25.6	23.0	13.0	11.9	22.5	21.4	8.6	7.6	20.2
3.2	26.4	16.6	15.5	25.4	22.8	12.8	11.7	22.3	21.1	8.5	7.4	20.0
5.1	26.2	16.4	15.3	25.2	22.6	12.6	11.5	22.1	20.9	8.3	7.2	18.8
7.0	25.3	15.5	13.9	24.3	21.4	11.2	10.5	21.1	20.3	7.4	6.3	18.4
8.1									17.3	5.2	3.8	17.3
8.9	23.9	13.7	12.6	22.9								
9.8					18.0	7.0	6.3	16.9				
10.8												
11.7	19.8	7.0	6.0	18.8								

* Prior to conducting tests pontoons numbers 2 and 3 in the M5 raft were loaded in still water to 14-, 10-, and 6-in. freeboards on the starboard and port sides, respectively. All freeboard measurements are in prototype inches.

TABLE 9

AVERAGE MINIMUM FREEBOARDS ON OUTBOARD SIDES
OF DOUBLE "V" PONTONS IN THE 7-PONTON M5 RAFT

Velocity Ft/Sec	M5 Raft Loaded to 14-Inch Freeboard in Still Water*						M5 Raft Loaded to 10-Inch Freeboard in Still Water*						M5 Raft Loaded to 6-Inch Freeboard in Still Water*					
	Ponton No. 1 Port Side	Ponton No. 2 Port Side	Ponton No. 3 Port Side	Ponton No. 5 Starboard Side	Ponton No. 6 Starboard Side	Ponton No. 7 Starboard Side	Ponton No. 1 Port Side	Ponton No. 2 Port Side	Ponton No. 3 Port Side	Ponton No. 5 Starboard Side	Ponton No. 6 Starboard Side	Ponton No. 7 Starboard Side	Ponton No. 1 Port Side	Ponton No. 2 Port Side	Ponton No. 3 Port Side	Ponton No. 5 Starboard Side	Ponton No. 6 Starboard Side	Ponton No. 7 Starboard Side
1.6	23.4	18.5	14.2	14.2	17.8	23.6	19.6	14.2	10.1	10.0	14.2	18.9	16.6	10.8	6.5	7.0	10.8	16.0
3.2	23.2	18.5	14.0	14.0	17.6	23.4	19.4	14.0	9.9	9.6	14.0	18.7	16.4	10.8	6.5	7.0	10.6	15.8
5.1	23.0	18.0	13.7	13.6	17.4	23.2	19.2	13.8	9.7	9.6	13.8	18.4	16.2	10.6	6.3	6.8	10.6	15.6
7.0	21.0	17.2	13.1	13.0	16.4	22.2	18.3	13.5	9.2	8.9	13.5	17.6	14.6	9.9	5.4	5.7	9.9	14.0
8.9	19.1	14.4	11.1	11.0	13.5	19.3	16.2	11.7	7.6	7.5	11.7	15.5	11.7	8.1	3.6	4.1	8.1	11.1
9.8													10.1	7.6	2.9	3.2	7.6	9.5
10.8	16.2	11.7	9.0	8.8	10.8	16.4	12.4	9.2	5.4	5.3	9.2	11.7						
12.0	13.5	9.0	6.8	6.8	8.1	13.7												

* Prior to conducting tests ponton No. 4 in the M5 raft was loaded in still water to 14-, 10-, and 6-in. freeboards on the starboard and portsides, respectively. All freeboard measurements are in prototype inches.

TABLE 10

LOCATION AND MAGNITUDE OF AVERAGE MINIMUM FREEBOARD ON SIDE OF PONTONS

14-Inch Freeboard Loading on Side in Still Water

Type "A" Scow Bow Ponton Unit			Type "B" Scow Bow Ponton Unit		
Velocity Ft/Sec	Distance from Bow on Side in Feet	Observed Average Freeboard in Inches	Velocity Ft/Sec	Distance from Bow on Side in Feet	Observed Average Freeboard in Inches
1.6	15.0	14.00	1.6	15.0	14.00
3.2	15.0	13.90	3.2	15.0	13.90
5.1	15.0	13.70	5.1	15.0	13.75
7.0	18.0	12.60	7.0	16.5	12.75
8.9	16.5	10.40	8.9	13.5	10.85
10.8	19.5	9.40	11.6	21.0	9.25
12.5	22.5	8.50	13.6	25.5	10.25
14.5	28.5	8.80	15.1	28.5	9.90
16.0	28.5	1.00	16.0	28.5	1.25
10-Inch Freeboard Loading on Side in Still Water					
1.6	15.0	10.00	1.6	15.0	10.00
3.2	15.0	9.90	3.2	15.0	9.90
5.1	15.0	9.75	5.1	15.0	9.75
7.0	13.5	8.50	7.0	16.5	9.00
8.9	16.5	6.15	8.9	13.5	6.75
10.8	18.0	4.80	11.6	21.0	4.75
12.5	22.5	4.10	14.0	27.0	4.40
14.5	27.0	3.75	14.6	28.5	3.00
6-Inch Freeboard Loading on Side in Still Water					
1.6	15.0	6.00	1.6	15.0	6.00
3.2	15.0	5.85	3.2	15.0	5.75
5.1	16.5	5.50	5.1	15.0	5.50
7.0	22.5	4.30	7.0	16.5	4.75
9.3	18.0	1.40	8.9	22.5	2.25
			11.6	20.0	1.25

TABLE 11

LOCATION AND MAGNITUDE OF AVERAGE MINIMUM FREEBOARD ON SIDE OF PONTONS

14-Inch Freeboard Loading on Side in Still Water

M5 Raft with Four Type "A" Scow Bow Ponton Units*			M5 Raft with Four Type "B" Scow Bow Ponton Units*		
Velocity Ft/Sec	Distance from Bow on Side in Feet	Observed Average Freeboard in Inches	Velocity Ft/Sec	Distance from Bow on Side in Feet	Observed Average Freeboard in Inches
1.6	15.0	14.00	1.6	15.0	14.00
3.2	15.0	13.90	3.2	15.0	13.90
5.1	15.0	13.65	5.1	15.0	13.60
7.0	19.5	12.80	7.0	20.0	12.10
8.9	21.5	10.40	8.9	22.0	9.60
11.3	27.0	3.40	10.8	27.0	3.30
10-Inch Freeboard Loading on Side in Still Water					
1.6	15.0	10.00	1.6	15.0	10.00
3.2	15.0	9.90	3.2	15.0	9.90
5.1	15.0	9.50	5.1	15.0	9.60
7.0	18.0	8.50	7.0	20.0	8.50
8.9	21.0	5.80	8.9	22.0	6.00
10.3	21.0	2.00	10.2	22.0	2.00
6-Inch Freeboard Loading on Side in Still Water					
1.6	15.0	6.00	1.6	15.0	6.00
3.2	15.0	5.85	3.2	15.0	5.90
5.1	15.0	5.65	5.1	15.0	5.50
7.0	18.0	4.30	7.0	19.5	5.00
8.9	21.0	1.30	8.9	22.5	1.50

* The freeboard data for the M5 raft are the average minimum freeboards measured on the starboard side of ponton No. 2.

TABLE 12

AVERAGE MINIMUM FREEBOARDS ON OUTBOARD SIDES
OF TYPE "A" SCOW BOW PONTONS IN THE 4-PONTON M5 RAFT

Velocity Ft/Sec	M5 Raft Loaded to 14-Inch Freeboard in Still Water*				M5 Raft Loaded to 10-Inch Freeboard in Still Water*				M5 Raft Loaded to 6-Inch Freeboard in Still Water*			
	Ponton No. 1 Port Side	Ponton No. 2 Port Side	Ponton No. 3 Starboard Side	Ponton No. 4 Starboard Side	Ponton No. 1 Port Side	Ponton No. 2 Port Side	Ponton No. 3 Starboard Side	Ponton No. 4 Starboard Side	Ponton No. 1 Port Side	Ponton No. 2 Port Side	Ponton No. 3 Starboard Side	Ponton No. 4 Starboard Side
1.6	25.7	16.7	16.6	25.6	23.6	12.8	12.8	23.2	20.9	8.8	8.6	20.3
3.2	25.5	16.6	16.4	25.4	23.4	12.6	12.6	23.0	20.7	8.6	8.4	19.9
5.1	25.3	16.4	16.2	25.2	22.9	12.4	12.4	22.8	20.4	8.3	8.1	19.6
7.0	24.8	15.8	15.7	24.9	22.0	11.5	11.4	21.4	19.8	7.6	7.3	19.0
8.9	21.7	13.1	13.0	21.8	18.9	8.6	8.5	18.5	16.9	4.7	4.3	16.2
10.3					15.3	5.2	5.2	14.9				
11.3	16.0	6.7	6.3	16.1								

* Prior to conducting tests pontons numbers 2 and 3 in the M5 raft were loaded in still water to 14-, 10-, and 6-in. freeboards on the starboard and port sides, respectively. All freeboard measurements are in prototype inches.

TABLE 13

LOCATION AND MAGNITUDE OF AVERAGE MINIMUM FREEBOARD ON SIDE OF PONTONS

14-Inch Freeboard Loading on Side in Still Water

M5 Raft with Seven Type "A" Scow Bow Ponton Units*			M5 Raft with Seven Type "B" Scow Bow Ponton Units*		
Velocity Ft/Sec	Distance from Bow on Side in Feet	Observed Average Freeboard in Inches	Velocity Ft/Sec	Distance from Bow on Side in Feet	Observed Average Freeboard in Inches
1.6	15.0	14.00	1.6	15.0	14.00
3.2	15.0	13.90	3.2	15.0	13.85
5.1	30.0	13.30	5.1	30.0	13.40
7.0	30.0	12.60	7.0	30.0	12.60
9.4	16.5	11.00	8.9	21.0	11.50
10.8	18.0	8.65	10.8	22.5	9.80
12.0	19.0	5.60	12.0	19.5	7.00
10-Inch Freeboard Loading on Side in Still Water					
1.6	13.5	10.00	1.6	15.0	10.00
3.2	13.5	9.90	3.2	15.0	9.90
5.1	27.5	9.50	5.1	30.0	9.50
7.0	30.0	8.30	7.0	30.0	8.50
9.4	16.5	6.00	8.9	19.5	6.75
11.0	18.0	4.00	10.8	18.0	4.00
			12.0	18.0	2.00
6-Inch Freeboard Loading on Side in Still Water					
1.6	13.5	6.00	1.6	13.5	6.00
3.2	13.5	5.80	3.2	13.5	5.70
5.1	13.5	5.45	5.1	13.5	4.70
7.0	25.0	4.35	7.0	30.0	3.30
9.4	16.5	2.00	8.9	30.0	1.50
			10.3	16.5	0.30

* The freeboard data for the M5 raft are the average minimum freeboards measured on the starboard side of ponton No. 4.

TABLE 14
 AVERAGE MINIMUM FREEBOARDS ON OUTBOARD SIDES
 OF TYPE "A" SCOW BOW PONTONS IN THE 7-PONTON M5 RAFT

Velocity Ft/Sec	M5 Raft Loaded to 14-Inch Freeboard in Still Water*						M5 Raft Loaded to 10-Inch Freeboard in Still Water*						M5 Raft Loaded to 6-Inch Freeboard in Still Water*					
	Ponton No. 1 Port Side	Ponton No. 2 Port Side	Ponton No. 3 Port Side	Ponton No. 5 Starboard Side	Ponton No. 6 Starboard Side	Ponton No. 7 Starboard Side	Ponton No. 1 Port Side	Ponton No. 2 Port Side	Ponton No. 3 Port Side	Ponton No. 5 Starboard Side	Ponton No. 6 Starboard Side	Ponton No. 7 Starboard Side	Ponton No. 1 Port Side	Ponton No. 2 Port Side	Ponton No. 3 Port Side	Ponton No. 5 Starboard Side	Ponton No. 6 Starboard Side	Ponton No. 7 Starboard Side
1.6	22.1	17.5	14.4	15.1	18.0	21.8	19.8	14.4	10.6	11.2	14.6	19.1	15.3	10.1	6.3	6.7	10.3	14.8
3.2	21.9	17.3	14.2	14.9	17.8	21.6	19.6	14.2	10.4	11.0	14.4	18.9	15.1	9.9	6.1	6.5	10.1	14.6
5.1	21.7	17.0	14.0	14.7	17.5	21.4	19.4	14.0	10.2	10.8	14.2	18.7	14.8	9.7	5.9	6.3	9.9	14.3
7.0	21.0	16.1	13.3	14.0	16.6	20.7	18.0	13.0	9.2	9.8	13.2	17.1	14.5	9.0	5.0	5.3	9.2	14.1
9.4	17.6	14.6	11.5	12.2	15.1	17.3	15.3	10.8	7.2	7.8	11.0	14.6	11.3	6.5	2.9	3.1	6.7	10.8
10.8	12.7	10.7	8.5	9.0	11.2	12.4												
11.0							10.3	7.7	4.7	5.3	7.9	9.6						
12.0	11.0	7.8	5.6	6.3	8.3	10.8												

* Prior to conducting test* ponton No. 4 in the M5 raft was loaded in still water to 14-, 10-, and 6-in. freeboards on the starboard and port sides, respectively. All freeboard measurements are in prototype inches.

TABLE 15

AVERAGE MINIMUM FREEBOARDS ON OUTBOARD SIDES
OF TYPE "B" SCOW BOW PONTONS IN THE 4-PONTON M5 RAFT

Velocity Ft/Sec	M5 Raft Loaded to 14-Inch Freeboard in Still Water*				M5 Raft Loaded to 10-Inch Freeboard in Still Water*				M5 Raft Loaded to 6-Inch Freeboard in Still Water*			
	Ponton No. 1 Port Side	Ponton No. 2 Port Side	Ponton No. 3 Starboard Side	Ponton No. 4 Starboard Side	Ponton No. 1 Port Side	Ponton No. 2 Port Side	Ponton No. 3 Starboard Side	Ponton No. 4 Starboard Side	Ponton No. 1 Port Side	Ponton No. 2 Port Side	Ponton No. 3 Starboard Side	Ponton No. 4 Starboard Side
1.6	28.6	17.3	17.1	27.7	25.9	13.3	13.5	24.8	23.9	9.5	9.9	22.7
3.2	28.4	17.1	16.9	27.5	25.7	13.1	13.3	24.6	23.7	9.4	9.7	22.5
5.1	28.2	16.8	16.6	27.3	25.3	12.8	13.1	24.5	23.5	9.2	9.4	22.3
7.0	27.2	15.1	15.3	26.4	25.0	11.5	11.7	23.9	23.2	8.9	8.1	22.0
8.9	23.7	11.7	12.0	22.8	22.5	7.9	8.5	21.4	19.2	4.0	4.3	18.6
10.2					19.8	4.0	4.2	18.6				
10.8	20.5	4.1	4.4	19.6								

* Prior to conducting tests pontoons numbers 2 and 3 in the M5 raft were loaded in still water to 14-, 10-, and 6-in. freeboards on the starboard and port sides, respectively. All freeboard measurements are in prototype inches.

TABLE 16

AVERAGE MINIMUM FREEBOARDS ON OUTBOARD SIDES
OF TYPE "B" SCOW BOW PONTONS IN THE 7-PONTON M5 RAFT

Velocity Ft/Sec	M5 Raft Loaded to 14-Inch Freeboard in Still Water*						M5 Raft Loaded to 10-Inch Freeboard in Still Water*						M5 Raft Loaded to 6-Inch Freeboard in Still Water*					
	Ponton No. 1 Port Side	Ponton No. 2 Port Side	Ponton No. 3 Port Side	Ponton No. 5 Starboard Side	Ponton No. 6 Starboard Side	Ponton No. 7 Starboard Side	Ponton No. 1 Port Side	Ponton No. 2 Port Side	Ponton No. 3 Port Side	Ponton No. 5 Starboard Side	Ponton No. 6 Starboard Side	Ponton No. 7 Starboard Side	Ponton No. 1 Port Side	Ponton No. 2 Port Side	Ponton No. 3 Port Side	Ponton No. 5 Starboard Side	Ponton No. 6 Starboard Side	Ponton No. 7 Starboard Side
1.6	26.5	20.7	16.0	16.5	20.5	25.7	23.9	17.5	12.4	12.8	16.7	22.7	18.7	11.9	7.2	7.9	12.4	18.7
3.2	26.3	20.5	15.8	16.3	20.3	25.5	23.7	17.3	12.2	12.6	16.5	22.1	18.5	11.7	7.0	7.7	12.2	18.5
5.1	25.8	20.3	15.1	16.1	20.1	25.0	23.0	17.1	11.7	12.3	16.3	21.5	17.8	11.0	6.3	6.8	11.7	17.8
7.0	23.6	18.5	13.7	14.0	18.3	22.8	22.3	16.6	11.5	11.9	15.8	20.6	15.1	9.6	4.1	4.8	10.1	15.3
8.9	20.6	17.6	12.4	12.6	17.4	19.8	18.3	15.0	10.4	10.6	14.2	17.3	12.6	7.0	2.5	2.9	7.7	12.3
10.3													9.2	5.4	0.9	1.2	6.1	9.0
10.8	19.5	15.8	10.1	10.4	15.6	18.3	15.3	11.4	7.7	8.1	10.6	14.6						
12.0	9.6	8.7	5.6	5.9	8.6	9.0	11.3	8.9	4.1	4.5	8.4	10.6						

* Prior to conducting tests ponton No. 4 in the M5 raft was loaded in still water to 14-, 10-, and 6-in. freeboards on the starboard and port sides, respectively. All freeboard measurements are in prototype inches.

TABLE 17

COMPARISON OF AVERAGE MINIMUM FREEBOARDS ON BOW OF PONTONS

14-Inch Freeboard Loading on Side in Still Water**					
Velocity Ft/Sec	M4 Ponton Unit*	Hollow "V" Ponton Unit*	Double "V" Ponton Unit*	Type "A" Scow Bow Ponton Unit*	Type "B" Scow Bow Ponton Unit*
	Observed Average Freeboard in Inches				
1.6	18.60	18.35	18.35	18.35	18.35
3.2	18.35	17.50	17.75	17.55	17.80
5.1	17.65	16.15	16.25	16.65	16.95
7.0	16.30	13.35	14.00	14.60	15.15
8.9	13.75	9.55	10.00	11.25	12.15
10.8	10.70	5.00	4.00	5.10	5.00
12.0	7.00	2.00	0.00	0.00	4.60
12.7	5.00	0.00			3.50
14.1	0.75				0.00
14.4	0.00				
10-Inch Freeboard Loading on Side in Still Water**					
Observed Average Freeboard in Inches					
1.6	14.40	14.25	14.25	14.25	14.25
3.2	14.10	13.25	13.65	13.50	13.65
5.1	13.15	11.75	12.35	12.10	12.65
7.0	11.00	8.75	9.35	9.00	10.30
8.9	7.15	3.00	1.85	4.15	6.35
9.3	6.25	2.00	0.00	3.50	5.25
9.8	4.75	0.00		2.10	3.80
10.5	2.75			0.00	1.75
11.0	1.05				0.00
11.3	0.00				
6-Inch Freeboard Loading on Side in Still Water**					
Observed Average Freeboard in Inches					
1.6	10.35	10.35	10.35	10.35	10.35
3.2	9.85	9.40	9.00	9.50	9.65
5.1	8.40	7.60	6.00	7.60	8.65
7.0	4.65	2.85	1.35	2.85	5.45
7.4	3.65	1.90	0.00	1.25	4.10
7.7	2.75	0.75		0.00	3.00
7.9	2.00	0.00			2.25
8.4	0.00				0.00

** Prior to conducting tests the ponton was loaded in still water to 14-, 10-, and 6-in. freeboards on the starboard and port sides, respectively.
 * The freeboard data for the ponton are the average minimum freeboard measured on the bow of the ponton.
 All freeboards are in prototype inches.

TABLE 18

COMPARISON OF AVERAGE MINIMUM FREEBOARDS ON SIDE OF PONTONS

14-Inch Freeboard Loading on Side in Still Water*					
Velocity Ft/Sec	M4 Ponton Unit	Hollow "V" Ponton Unit	Double "V" Ponton Unit	Type "A" Scow Bow Ponton Unit	Type "B" Scow Bow Ponton Unit
	Observed Average Freeboard in Inches				
1.6	14.00	14.00	14.00	14.00	14.00
3.2	13.90	13.90	13.90	13.90	13.90
5.1	13.70	13.70	13.50	13.70	13.75
7.0	13.25	13.30	12.80	12.60	12.75
8.9	11.90	12.20	11.50	10.40	10.85
10.8	10.50	10.60	10.80	9.40	9.65
12.5	8.75	9.60	9.40	8.50	9.50
13.9	7.25	7.70	8.35	8.50	10.20
14.5	6.65	7.10	8.30	8.80	10.20
15.1	5.90	6.40	8.50	7.50	9.90
16.0	4.85	4.85	9.50	1.00	1.25
10-Inch Freeboard Loading on Side in Still Water*					
Observed Average Freeboard in Inches					
1.6	10.00	10.00	10.00	10.00	10.00
3.2	9.85	9.90	9.90	9.90	9.90
5.1	9.45	9.70	9.70	9.75	9.75
7.0	8.75	9.40	9.00	8.50	9.00
8.9	7.15	8.10	7.40	6.15	6.75
10.8	4.70	6.10	5.20	4.80	4.95
11.6	3.75	5.10	4.90	4.25	4.75
12.5	2.75	3.90	4.00	4.00	4.60
13.5		2.50	3.40	3.85	4.60
14.5				3.75	3.00
6-Inch Freeboard Loading on Side in Still Water*					
Observed Average Freeboard in Inches					
1.6	5.95	6.00	6.00	6.00	6.00
3.2	5.70	5.80	5.80	5.85	5.75
5.1	5.20	5.60	5.40	5.50	5.50
7.0	4.45	5.20	4.50	4.30	4.75
8.9	2.10	4.30	4.50	2.00	2.25
9.3		3.85	2.30	1.40	2.00
10.8		2.20			1.35
11.6					1.25

* Prior to conducting tests the ponton was loaded in still water to 14-, 10-, and 6-in. freeboards on the starboard and port sides, respectively. All freeboards are in prototype inches.

TABLE 19

COMPARISON OF AVERAGE MINIMUM FREEBOARDS ON BOWS
OF TWO CENTER PONTONS IN THE 4-PONTON M5 RAFT

14-Inch Freeboard Loading on Side in Still Water**					
Velocity Ft/Sec	Four M ₄ Ponton Units*	Four Hollow "V" Ponton Units*	Four Double "V" Ponton Units*	Four Type "A" Scow Bow Ponton Units*	Four Type "B" Scow Bow Ponton Units*
	Observed Average Freeboard in Inches				
1.6	18.45	20.00	19.40	19.80	19.90
3.2	18.20	19.00	18.60	19.25	19.35
5.1	17.50	17.10	17.75	18.40	18.80
7.0	16.10	14.00	16.20	17.00	17.50
8.9	13.55	8.50	11.50	13.10	13.60
10.5	9.70	3.00	6.85	7.50	6.00
10.8		1.70	5.75	6.35	4.10
11.3			3.75	4.25	
11.7			2.40		
10-Inch Freeboard Loading on Side in Still Water**					
Velocity Ft/Sec	Four M ₄ Ponton Units*	Four Hollow "V" Ponton Units*	Four Double "V" Ponton Units*	Four Type "A" Scow Bow Ponton Units*	Four Type "B" Scow Bow Ponton Units*
	Observed Average Freeboard in Inches				
1.6	14.50	15.90	15.80	15.80	16.10
3.2	14.20	15.00	15.00	15.25	15.80
5.1	12.75	11.75	14.00	14.35	15.10
7.0	9.25	8.35	11.50	12.00	13.00
8.9	2.60	2.40	9.50	6.35	8.85
9.5		0.00	4.50	3.50	6.15
9.8			3.50	2.35	4.60
10.2				0.50	2.60
10.3				0.35	
6-Inch Freeboard Loading on Side in Still Water**					
Velocity Ft/Sec	Four M ₄ Ponton Units*	Four Hollow "V" Ponton Units*	Four Double "V" Ponton Units*	Four Type "A" Scow Bow Ponton Units*	Four Type "B" Scow Bow Ponton Units*
	Observed Average Freeboard in Inches				
1.6	10.60	12.00	11.25	11.75	12.10
3.2	10.25	10.30	10.65	11.10	11.70
5.1	8.75	7.50	9.25	9.75	10.40
7.0	4.60	2.10	5.00	6.75	7.60
7.7	3.10	0.50	2.00	4.75	6.00
7.9		0.00	1.00	4.00	5.50
8.1			0.00	3.50	4.85
8.6				1.65	3.50
8.9				0.85	2.65

** Prior to conducting tests pontons No. 2 and 3 in the M5 raft were loaded in still water to 14-, 10-, and 6-in. freeboards on the starboard and port sides, respectively.

* The freeboard data for the M5 raft are the average minimum freeboards measured on the bows of pontons No. 2 and 3.

All freeboard measurements are in prototype inches.

TABLE 20

COMPARISON OF AVERAGE MINIMUM FREEBOARDS ON INBOARD SIDES
OF TWO CENTER PONTONS IN THE 4-PONTON M5 RAFT

14-Inch Freeboard Loading on Side in Still Water**					
Velocity Ft/Sec	Four M4 Ponton Units*	Four Hollow "V" Ponton Units*	Four Double "V" Ponton Units*	Four Type "A" Scow Bow Ponton Units*	Four Type "B" Scow Bow Ponton Units*
	Observed Average Freeboard in Inches				
1.6	14.00	14.00	14.00	14.00	14.00
3.2	13.85	13.90	13.80	13.85	13.80
5.1	13.40	13.50	13.50	13.70	13.60
7.0	13.00	13.00	12.50	13.00	11.85
8.9	11.00	8.50	10.50	10.60	9.50
10.8	5.50	3.25	5.90	5.30	3.30
11.3			4.50	3.60	
11.7			3.50		
10-Inch Freeboard Loading on Side in Still Water**					
Observed Average Freeboard in Inches					
1.6	10.00	10.00	10.00	10.00	10.00
3.2	9.90	9.80	9.95	9.90	9.85
5.1	9.50	9.70	9.85	9.35	9.70
7.0	8.10	9.10	8.20	8.60	8.40
8.9	4.60	6.00	5.50	5.65	6.00
9.8		3.20	3.90	3.25	3.65
10.2				2.10	2.20
10.3				1.80	
6-Inch Freeboard Loading on Side in Still Water**					
Observed Average Freeboard in Inches					
1.6	6.00	6.00	6.00	6.00	6.00
3.2	5.85	5.70	6.00	5.80	5.70
5.1	5.60	5.35	5.65	5.50	5.40
7.0	4.85	4.50	4.00	4.50	5.20
7.7	3.40	3.50	2.80	3.60	3.75
8.1		2.75	2.30	1.90	3.20
8.6		1.80		1.95	2.15
8.9				1.35	1.30

** Prior to conducting tests pontoons No. 2 and 3 in the M5 raft were loaded in still water to 14-, 10-, and 6-in. freeboards on the starboard and port sides, respectively.
* The freeboard data for the M5 raft are the average minimum freeboards measured on starboard side of ponton No. 2 and the port side of ponton No. 3.
All freeboard measurements are in prototype inches.

TABLE 21

COMPARISON OF AVERAGE MINIMUM FREEBOARDS ON BOW
OF CENTER PONTON IN THE 7-PONTON M5 RAFT

14-Inch Freeboard Loading on Side in Still Water**				
Velocity Ft/Sec	Seven Hollow "V" Ponton Units*	Seven Double "V" Ponton Units*	Seven Type "A" Scow Bow Ponton Units*	Seven Type "B" Scow Bow Ponton Units*
	Observed Average Freeboard in Inches			
1.6	18.35	18.35	18.35	18.25
3.2	17.25	17.80	18.00	17.80
5.1	14.50	16.25	16.65	16.75
7.0	10.50	11.75	14.00	14.40
8.9	2.50	4.65	8.65	10.50
9.4	0.00	2.10	6.35	8.30
9.8		0.00	3.90	6.35
10.3			0.00	3.75
10.9				0.00
10-Inch Freeboard Loading on Side in Still Water**				
Observed Average Freeboard in Inches				
1.6	14.20	14.30	14.30	14.35
3.2	12.75	13.45	13.50	13.95
5.1	9.65	11.35	11.25	12.50
7.0	4.00	7.00	7.25	9.25
8.1	0.00	2.30	3.00	5.50
8.6		0.00	0.60	3.65
8.7			0.00	3.25
9.4				0.00
6-Inch Freeboard Loading on Side in Still Water**				
Observed Average Freeboard in Inches				
1.6	10.10	10.25	10.20	10.35
3.2	8.85	9.35	9.25	9.25
5.1	4.25	6.75	7.25	6.85
6.5	0.00	2.80	3.00	2.50
7.0		1.15	0.85	0.30
7.1		0.95	0.50	0.00
7.2		0.60	0.00	
7.4		0.00		

** Prior to starting tests ponton No. 4 in the M5 raft was loaded in still water to 14-, 10-, and 6-in. freeboards on the starboard and port sides, respectively.

* The freeboard data for the M5 raft are the average minimum freeboards measured on the bow of ponton No. 4.
All freeboard measurements are in prototype inches.

TABLE 22

COMPARISON OF AVERAGE MINIMUM FREEBOARDS ON SIDE
OF CENTER PONTON IN THE 7-PONTON M5 RAFT

14-Inch Freeboard Loading on Side in Still Water**				
Velocity Ft/Sec	Seven Hollow "V" Ponton Units*	Seven Double "V" Ponton Units*	Seven Type "A" Scow Bow Ponton Units*	Seven Type "B" Scow Bow Ponton Units*
	Observed Average Freeboard in Inches			
1.6	14.00	14.00	14.00	14.00
3.2	13.90	13.90	13.90	13.85
5.1	13.50	13.20	13.30	13.40
7.0	12.40	12.40	12.60	12.60
8.9	10.40	10.80	11.30	11.50
9.4	9.95	10.60	11.00	11.00
10.3	8.25	9.50	9.50	10.20
10.8	7.60	8.80	8.65	9.80
11.0	7.25	8.55	8.30	9.25
12.0	4.30	6.30	5.60	7.00
10-Inch Freeboard Loading on Side in Still Water**				
Observed Average Freeboard in Inches				
1.6	10.00	10.00	10.00	10.00
3.2	9.70	9.90	9.90	9.90
5.1	9.40	9.70	9.50	9.50
7.0	8.30	9.20	8.30	8.50
8.9	5.60	7.70	6.50	6.75
9.4	4.80	7.00	6.00	6.00
10.8	2.50	5.00	4.10	4.00
11.0			4.00	3.75
12.0				2.00
6-Inch Freeboard Loading on Side in Still Water**				
Observed Average Freeboard in Inches				
1.6	6.00	6.00	6.00	6.00
3.2	5.60	5.80	5.80	5.70
5.1	5.00	5.20	5.45	4.70
7.0	4.10	4.10	4.35	3.30
8.9	2.90	2.90	2.50	1.50
9.4		2.65	2.00	1.10
9.8		2.20		0.70
10.3				0.30

** Prior to conducting tests ponton No. 4 in the M5 raft was loaded in still water to 14-, 10-, and 6-in. freeboards on the starboard and port sides, respectively.

* The freeboard data for the M5 raft are the average minimum freeboards measured on the starboard side of ponton No. 4.
All freeboards are in prototype inches.

TABLE 23

VELOCITIES AT WHICH MINIMUM FREEBOARD
ON SIDE OF CRITICAL PONTON IN RAFT BECOMES ZERO

Freeboard	4-Ponton Raft			7-Ponton Raft		
	14 Inch	10 Inch	6 Inch	14 Inch	10 Inch	6 Inch
M4 Ponton	10.7	8.9	7.7	-	-	-
Hollow "V" Ponton	10.7	9.6	8.5	11.8	10.7	8.9
Double "V" Ponton	11.6	9.7	8.0	12.0	10.7	9.6
Type "A" Scow Bow	11.3	10.1	8.9	12.0	11.0	9.4
Type "B" Scow Bow	10.8	10.1	8.9	12.5	12.0	10.1

VELOCITIES AT WHICH MINIMUM FREEBOARD
ON BOW OF CRITICAL PONTON IN RAFT BECOMES ZERO*

Freeboard	4-Ponton Raft			7-Ponton Raft		
	14 Inch	10 Inch	6 Inch	14 Inch	10 Inch	6 Inch
M4 Ponton	*	8.6	*	-	-	-
Hollow "V" Ponton	10.5	8.9	7.0	8.5	7.2	5.6
Double "V" Ponton	10.7	9.3	7.7	8.3	7.9	6.9
Type "A" Scow Bow	11.0	9.5	8.2	9.0	8.0	7.0
Type "B" Scow Bow	11.0	9.8	8.9	10.0	8.5	7.0

* Side of ponton submerged before zero freeboard at bow obtained.

Note: No tests run with M4 ponton in 7-ponton raft.

PLATES

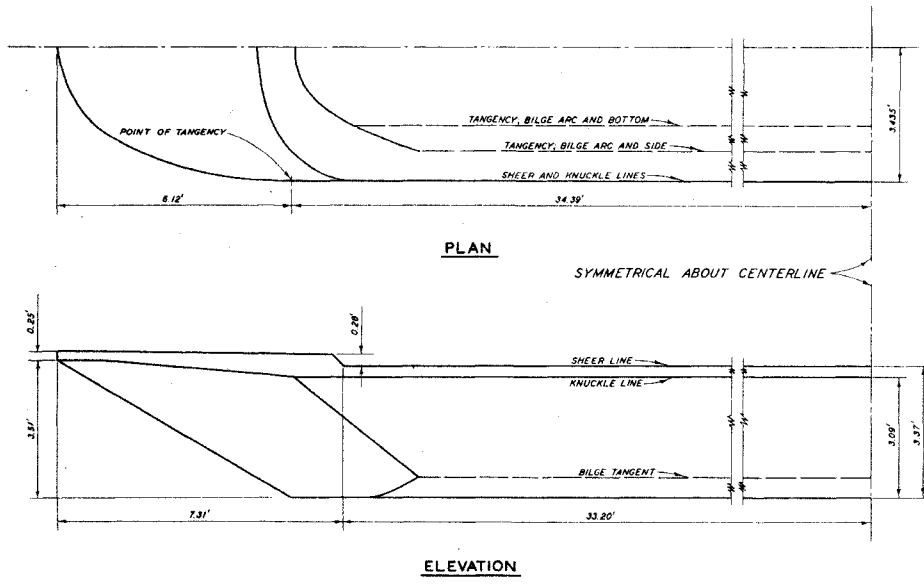

TEST CONDITIONS

PONTON LOADED IN STILL WATER TO FREEBOARDS OF 14, 10, AND 6 INCHES, RESPECTIVELY, ON THE SIDE AT START OF TEST.
 PONTON ANCHORED BY LINE OVER BOW CONNECTED TO CAPSTAN.
 LENGTH OF ANCHOR LINE EQUALS 10 TIMES DEPTH OF FLOW
 DEPTH OF FLOW EQUALS 20 FEET.

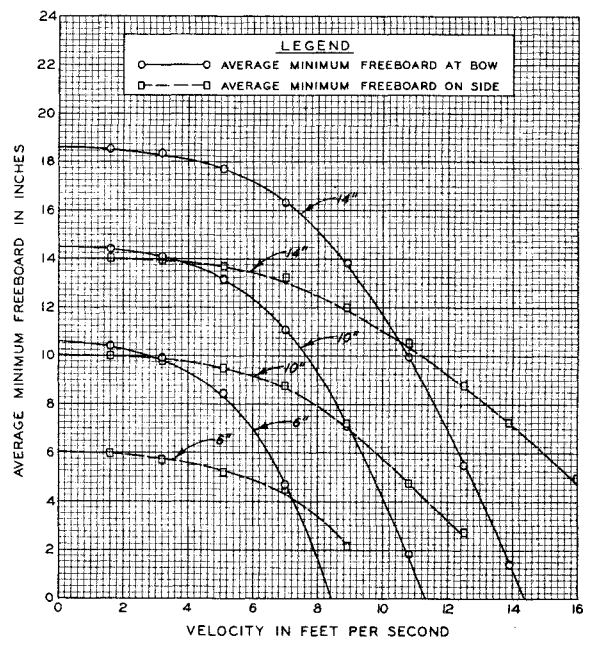

MODEL STUDY OF
 PONTONS FOR M5 BRIDGE
**AVERAGE MINIMUM FREEBOARD
 VELOCITY CURVES**

M4 PONTON - SINGLE PONTON
 SCALE

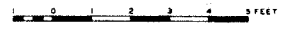

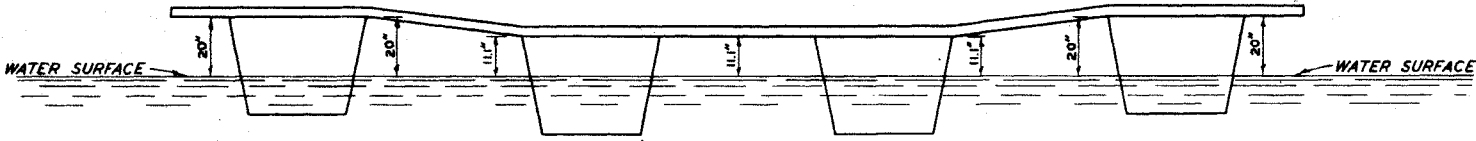

COMPUTED PROTOTYPE RAFT DEFLECTIONS

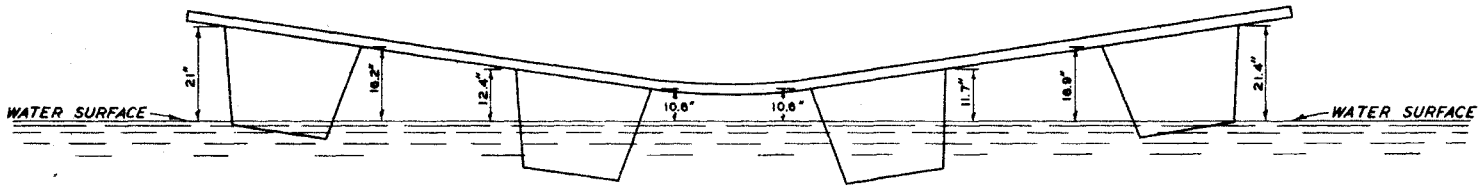

ACTUAL MODEL RAFT DEFLECTIONS

NOTES: COMPUTED PROTOTYPE RAFT DEFLECTIONS FURNISHED BY
ENGINEER BOARD, FORT BELVOIR, VIRGINIA.
ALL MODEL RAFT DEFLECTIONS MEASURED IN A VERTICAL
DIRECTION IN STILL WATER.
MEASUREMENTS ARE IN PROTOTYPE INCHES.
RAFT LOADING-80-TONS ON 17.5-FOOT BASE.

MODEL STUDY OF
PONTONS FOR M5 BRIDGE
M5 RAFT DEFLECTIONS
M4 PONTONS IN RAFT

SCALE



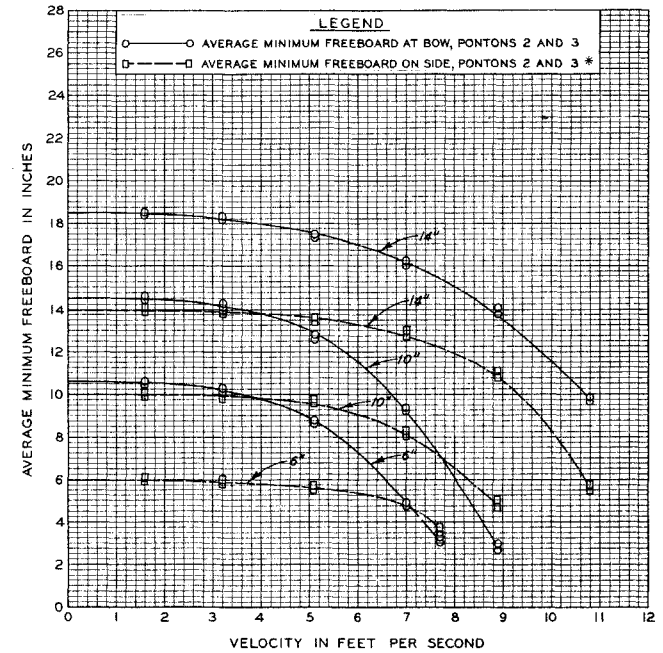
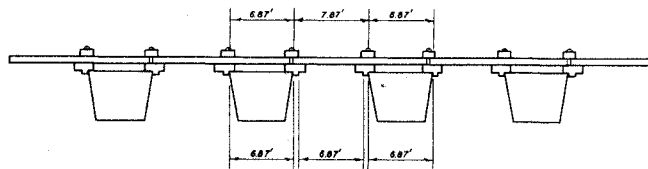
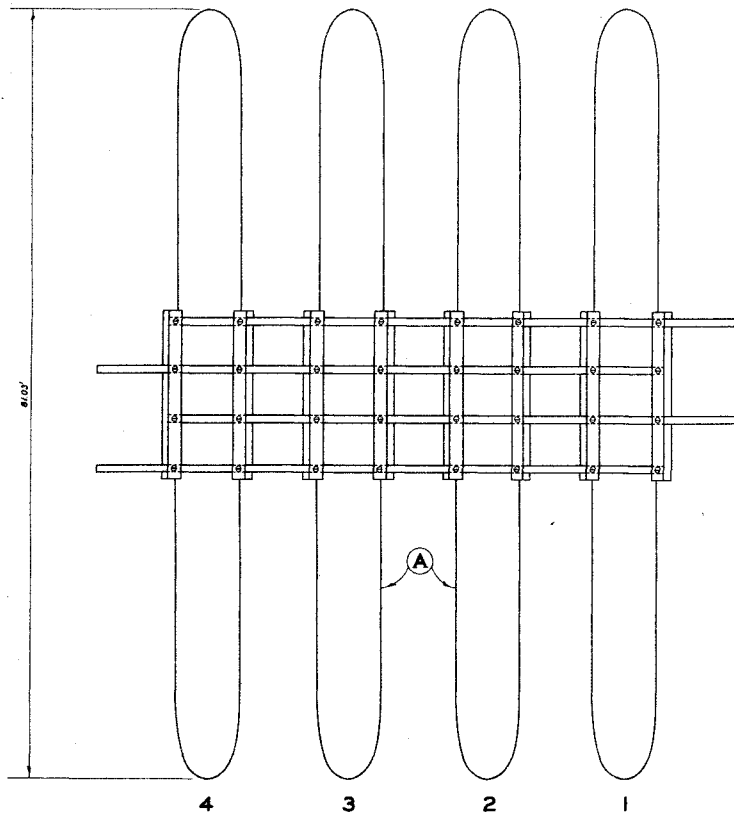

* FREEBOARD MEASUREMENTS TAKEN ALONG SIDES DENOTED BY SYMBOL (A)

TEST CONDITIONS

PONTONS ANCHORED BY LINES OVER BOW CONNECTED TO CAPSTANS.
 LENGTH OF ANCHOR LINE EQUALS 10 TIMES DEPTH OF FLOW.
 DEPTH OF FLOW EQUALS 20 FEET.
 PONTONS NUMBERS 2 AND 3 IN THE M5 RAFT WERE LOADED IN STILL WATER TO 14, 10, AND 6 INCHES FREEBOARDS ON THE STARBOARD AND PORT SIDES, RESPECTIVELY, AT START OF TEST.

MODEL STUDY OF
 PONTONS FOR M5 BRIDGE
**AVERAGE MINIMUM FREEBOARD
 VELOCITY CURVES**
 M4 PONTON—FOUR PONTON M5 RAFT

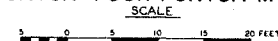

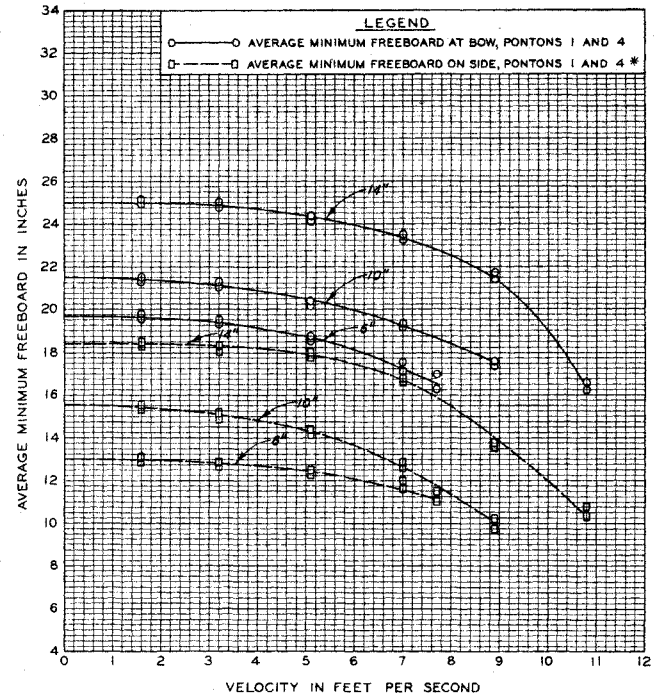
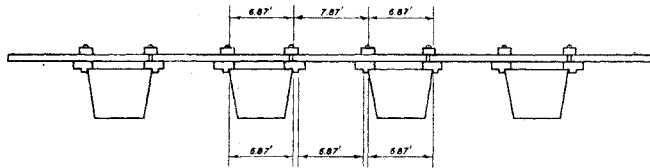
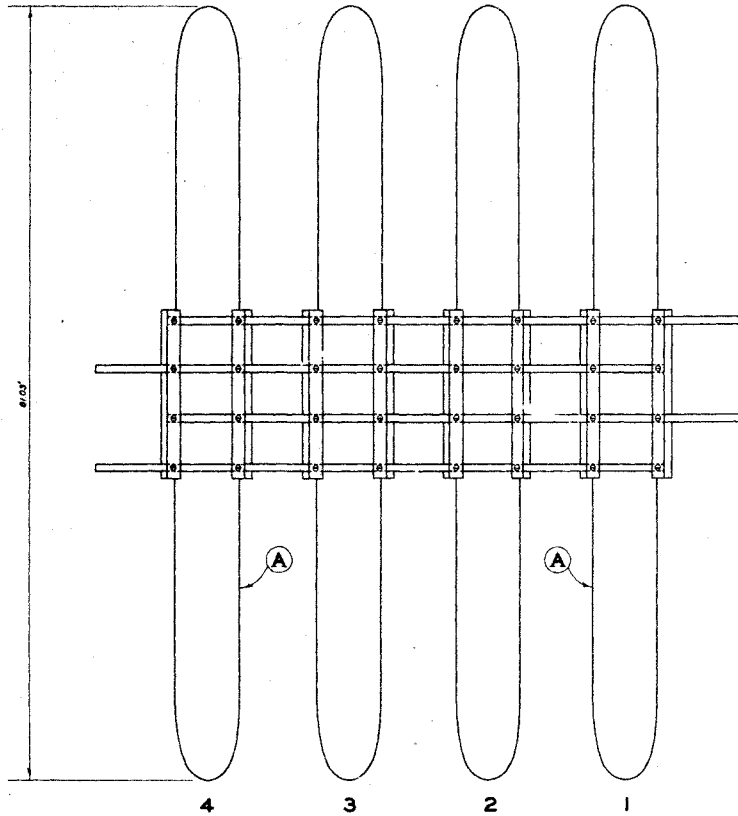

* FREEBOARD MEASUREMENTS TAKEN ALONG SIDES DENOTED BY SYMBOL (A)

TEST CONDITIONS

PONTONS ANCHORED BY LINES OVER BOW CONNECTED TO CAPSTANS.
 LENGTH OF ANCHOR LINE EQUALS 10 TIMES DEPTH OF FLOW.
 DEPTH OF FLOW EQUALS 20 FEET.
 PONTONS NUMBERS 2 AND 3 IN THE M5 RAFT WERE LOADED IN STILL WATER TO 14, 10, AND 6 INCHES FREEBOARDS ON THE STARBOARD AND PORT SIDES, RESPECTIVELY, AT START OF TEST.

MODEL STUDY OF
 PONTONS FOR M5 BRIDGE
**AVERAGE MINIMUM FREEBOARD
 VELOCITY CURVES**
 M4 PONTON-FOUR PONTON M5 RAFT
 SCALE



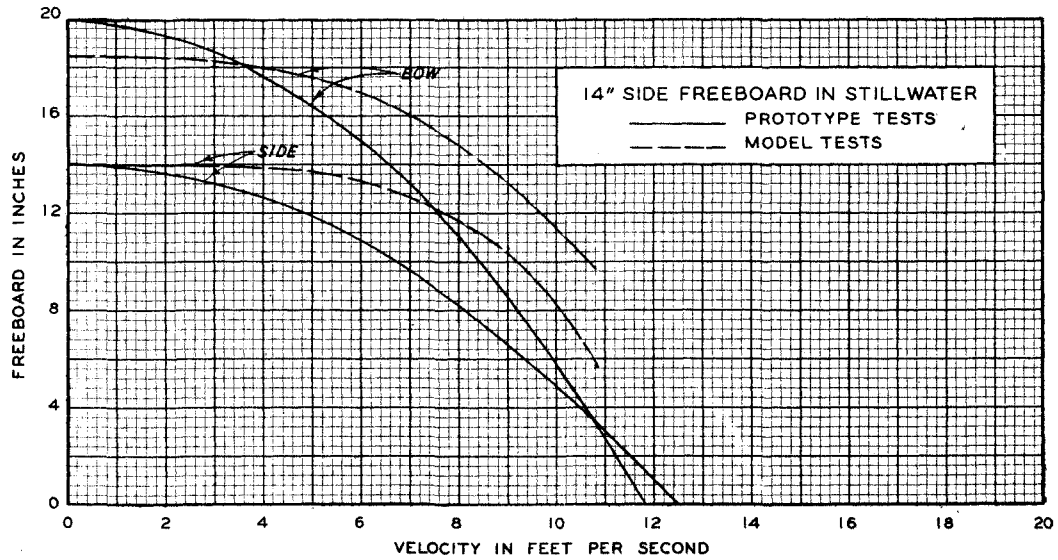
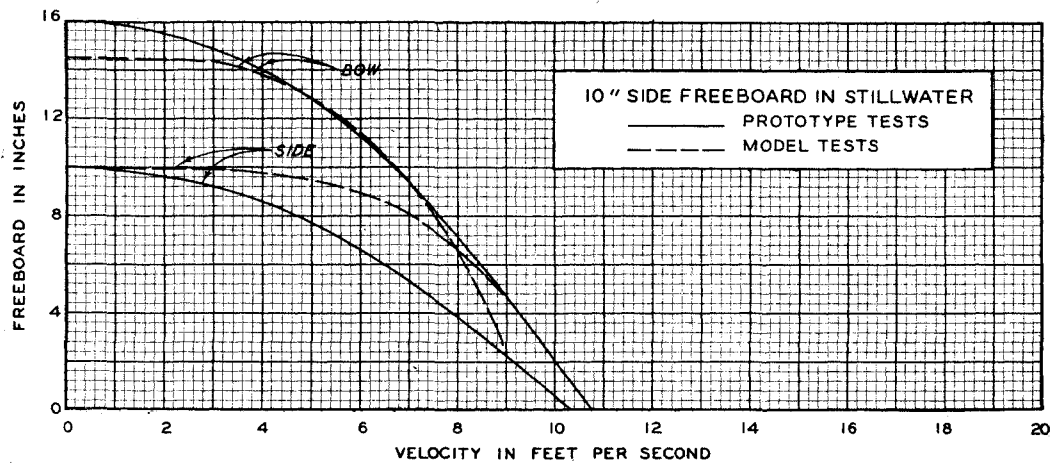
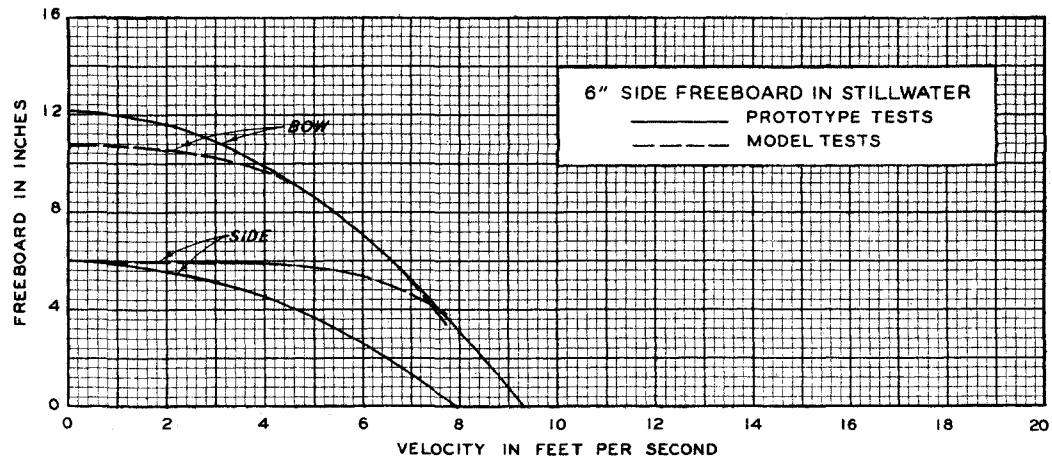

VELOCITY-FREEBOARD CURVES
COMPARISON BETWEEN PROTOTYPE AND MODEL TESTS OF M4 PONTON IN FOUR PONTON RAFT

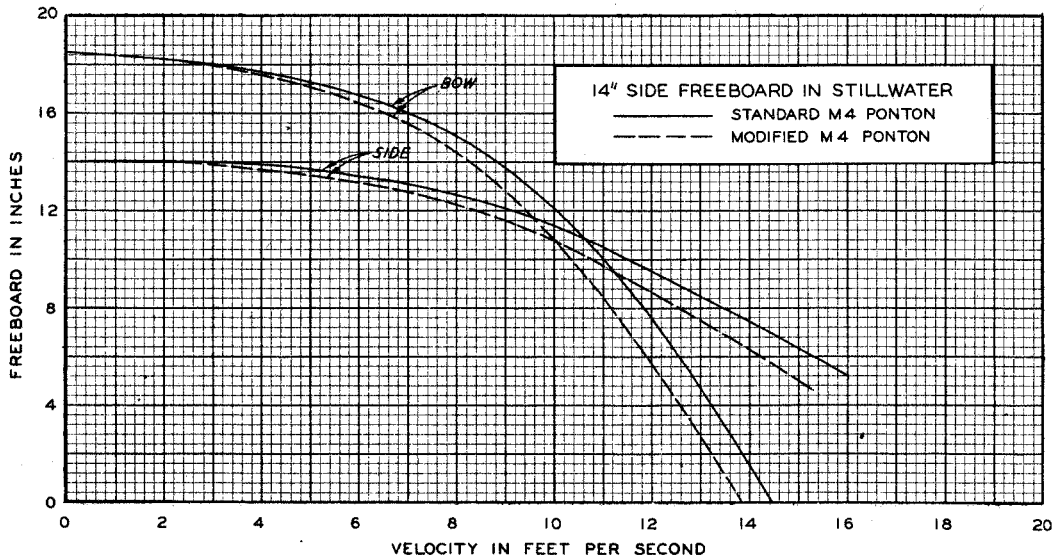
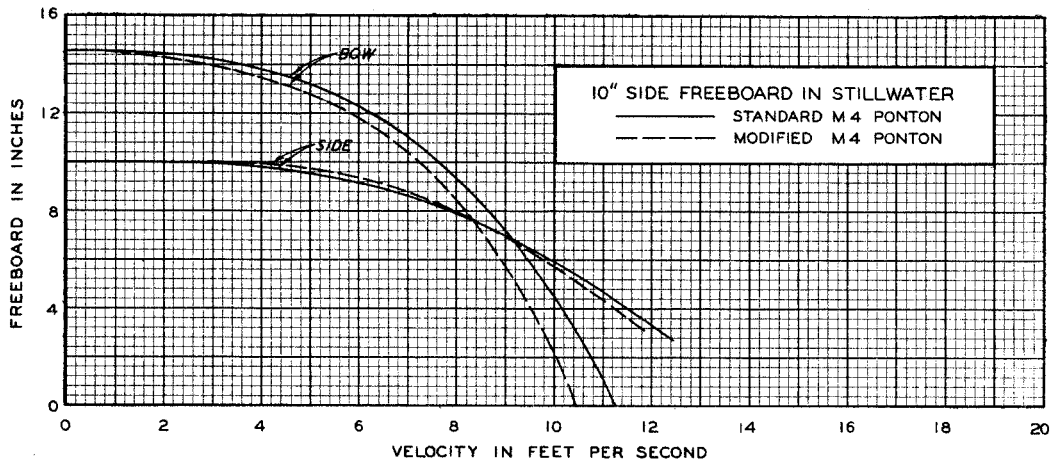
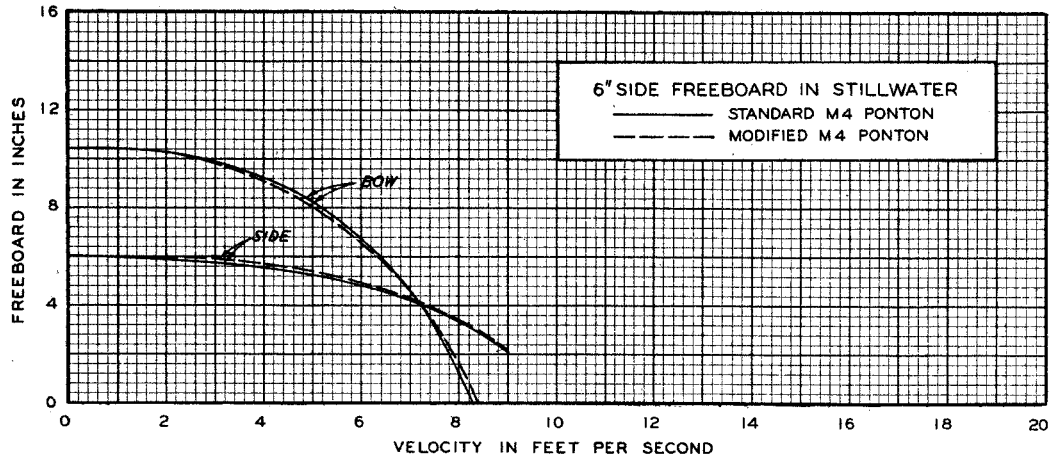

VELOCITY-FREEBOARD CURVES
COMPARISON BETWEEN STANDARD
M4 PONTON AND MODIFIED M4 PONTON

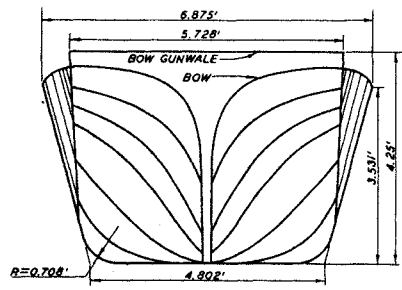
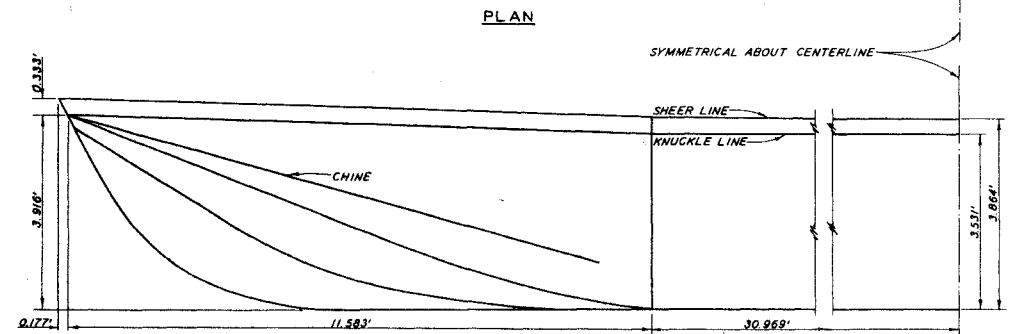
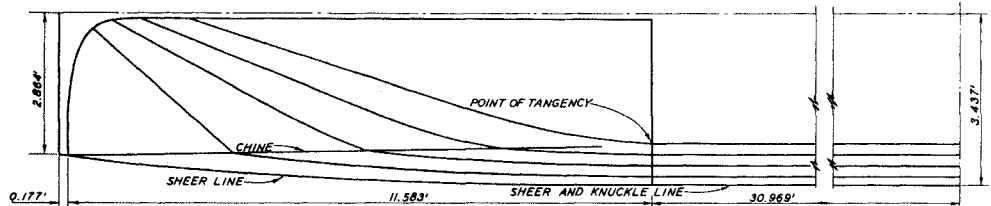

TEST CONDITIONS

PONTON LOADED IN STILL WATER TO FREEBOARDS OF 14, 10, AND 6 INCHES, RESPECTIVELY ON THE SIDE AT START OF TEST.
 PONTON ANCHORED BY LINE OVER BOW CONNECTED TO CAPSTAN.
 LENGTH OF ANCHOR LINE EQUALS 10 TIMES DEPTH OF FLOW.
 DEPTH OF FLOW EQUALS 20 FEET.

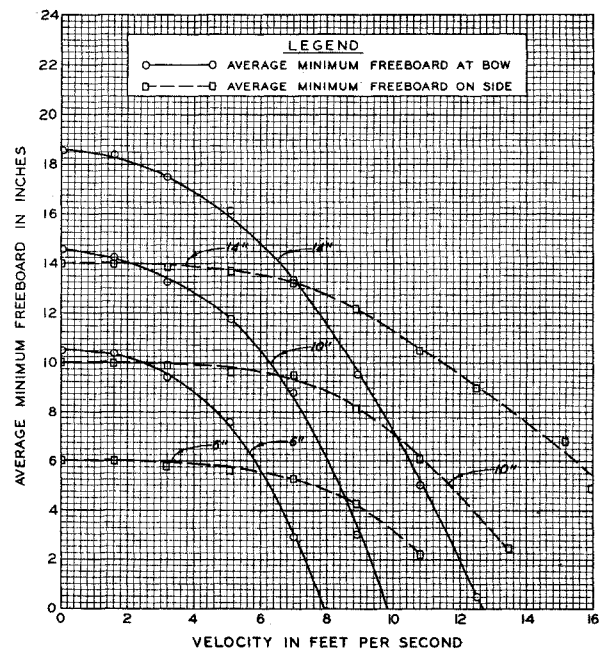

MODEL STUDY OF
 PONTONS FOR M5 BRIDGE
**AVERAGE MINIMUM FREEBOARD
 VELOCITY CURVES**

HOLLOW "V" PONTON-SINGLE PONTON

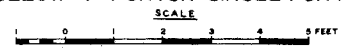

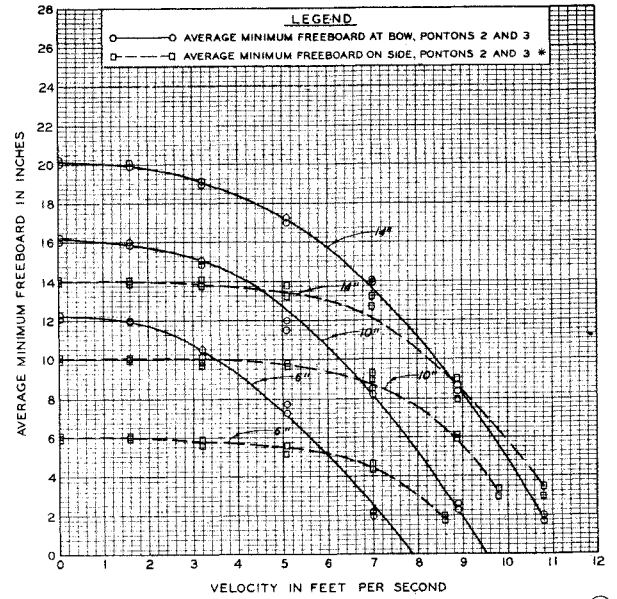
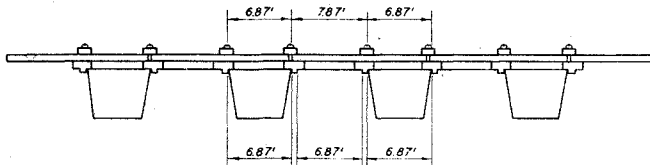
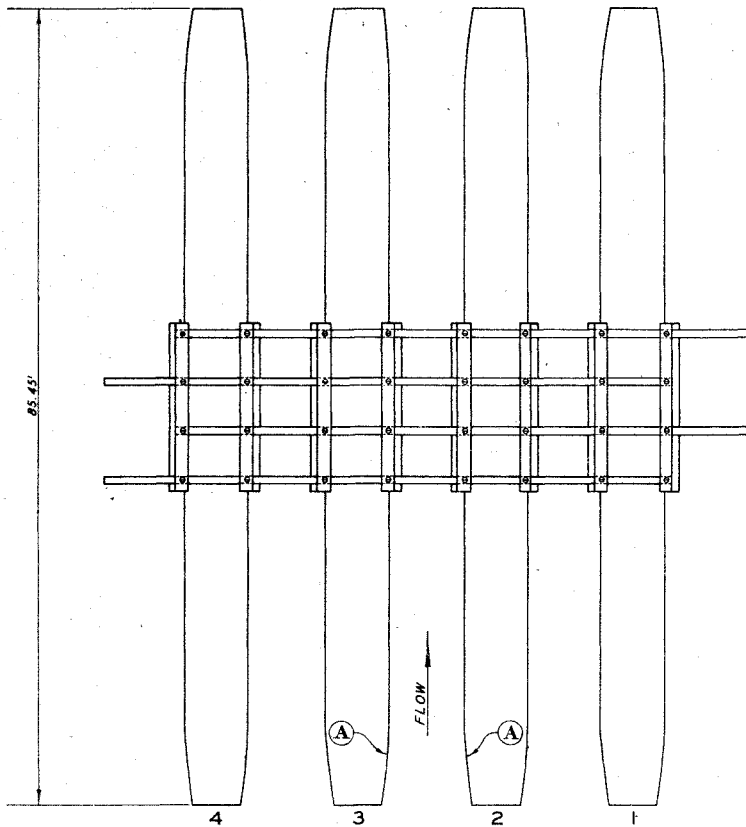

* FREEBOARD MEASUREMENTS TAKEN ALONG SIDES DENOTED BY SYMBOL (A)

TEST CONDITIONS

PONTONS ANCHORED BY LINES OVER BOW CONNECTED TO CAPSTANS. LENGTH OF ANCHOR LINE EQUALS 10 TIMES DEPTH OF FLOW. DEPTH OF FLOW EQUALS 20 FEET.

PONTONS NUMBERS 2 AND 3 IN THE M5 RAFT WERE LOADED IN STILL WATER TO 14, 10, AND 6 INCHES FREEBOARDS ON THE STARBOARD AND PORT SIDES, RESPECTIVELY, AT START OF TEST.

**MODEL STUDY OF
PONTONS FOR M5 BRIDGE
AVERAGE MINIMUM FREEBOARD
VELOCITY CURVES**

HOLLOW "V" PONTON - FOUR PONTON M5 RAFT

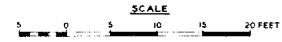

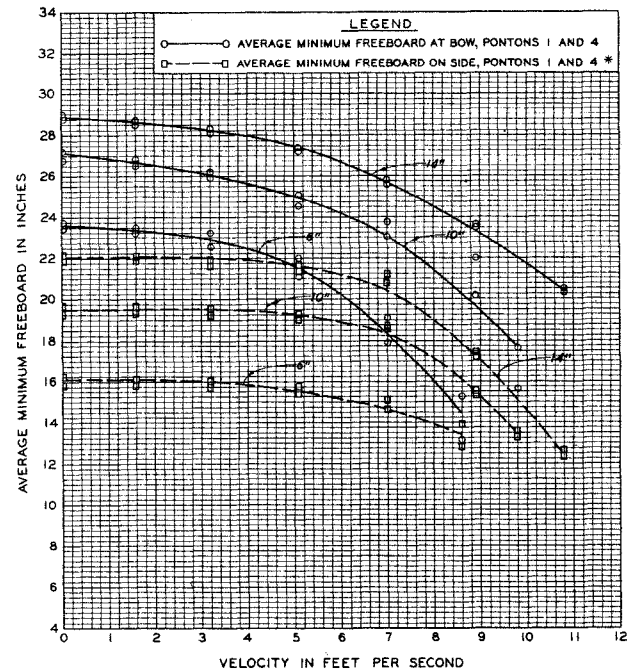
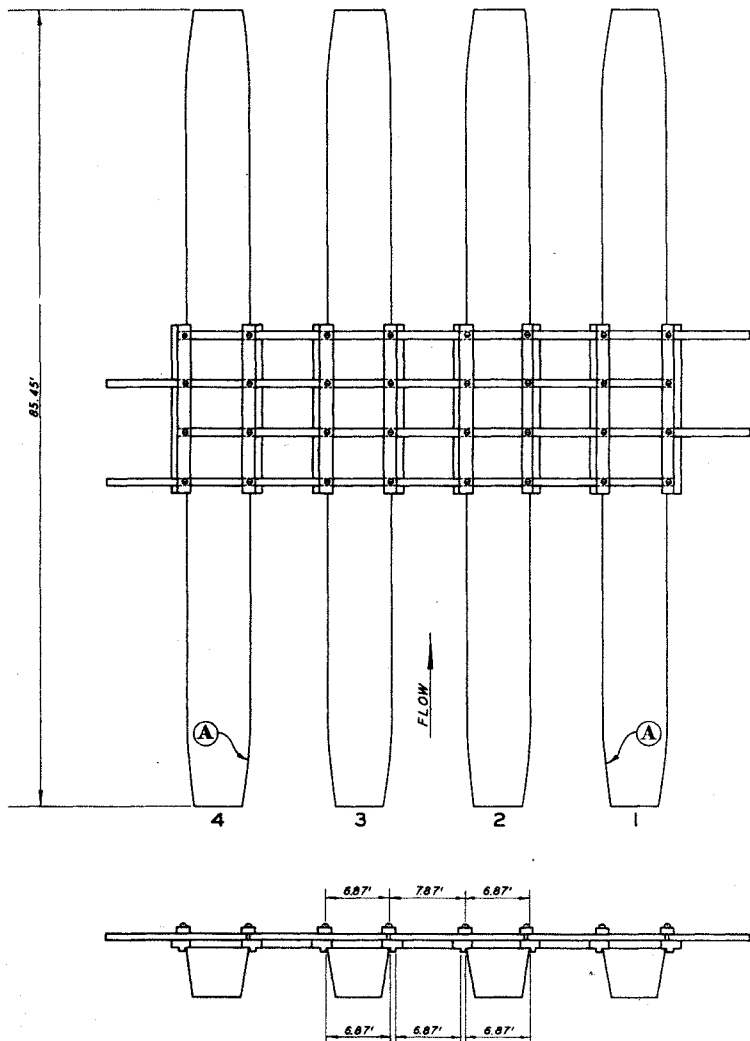

* FREEBOARD MEASUREMENTS TAKEN ALONG SIDES DENOTED BY SYMBOL (A)

TEST CONDITIONS

PONTONS ANCHORED BY LINES OVER BOW CONNECTED TO CAPSTANS.
 LENGTH OF ANCHOR LINE EQUALS 10 TIMES DEPTH OF FLOW.
 DEPTH OF FLOW EQUALS 20 FEET.
 PONTONS NUMBERS 2 AND 3 IN THE M5 RAFT WERE LOADED IN STILL WATER TO 14, 10, AND 6 INCHES FREEBOARDS ON THE STARBOARD AND PORT SIDES, RESPECTIVELY, AT START OF TEST.

MODEL STUDY OF
 PONTONS FOR M5 BRIDGE
**AVERAGE MINIMUM FREEBOARD
 VELOCITY CURVES**
 HOLLOW "V" PANTON - FOUR PANTON M5 RAFT

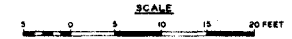

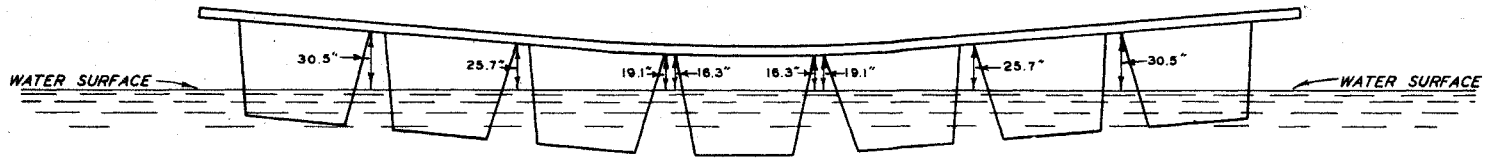

COMPUTED PROTOTYPE RAFT DEFLECTIONS

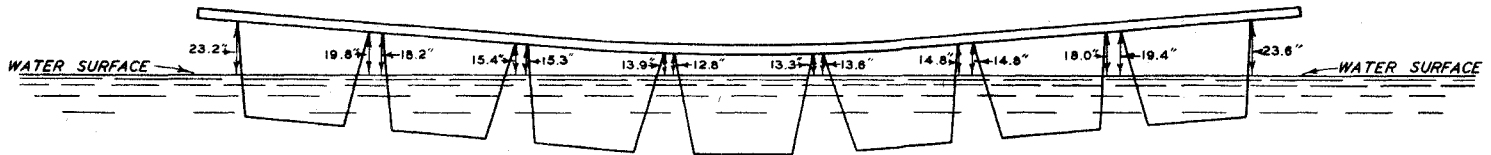

ACTUAL MODEL RAFT DEFLECTIONS

NOTES: COMPUTED PROTOTYPE RAFT DEFLECTIONS FURNISHED BY
ENGINEER BOARD, FORT BELVOIR, VIRGINIA.
ALL MODEL RAFT DEFLECTIONS MEASURED IN A VERTICAL
DIRECTION IN STILL WATER.
MEASUREMENTS ARE IN PROTOTYPE INCHES
RAFT LOADING -150-TONS ON 24.0 FOOT BASE.

MODEL STUDY OF
PONTONS FOR M5 BRIDGE
M5 RAFT DEFLECTIONS
HOLLOW "V" PONTONS IN RAFT

SCALE

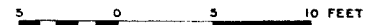

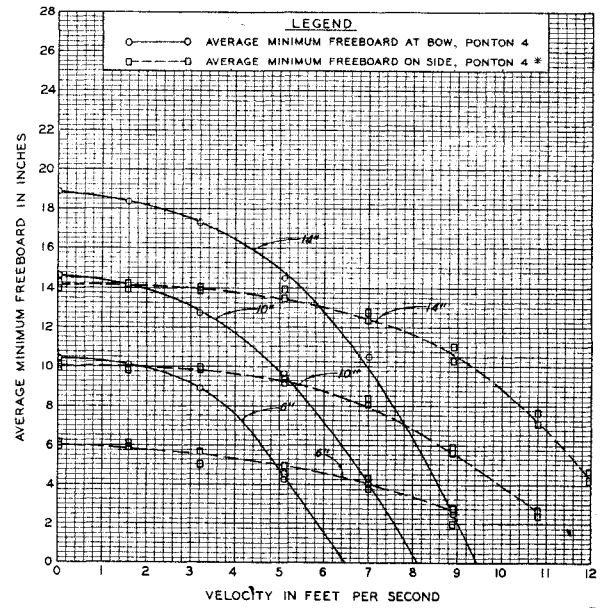
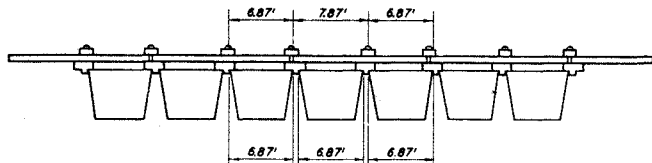
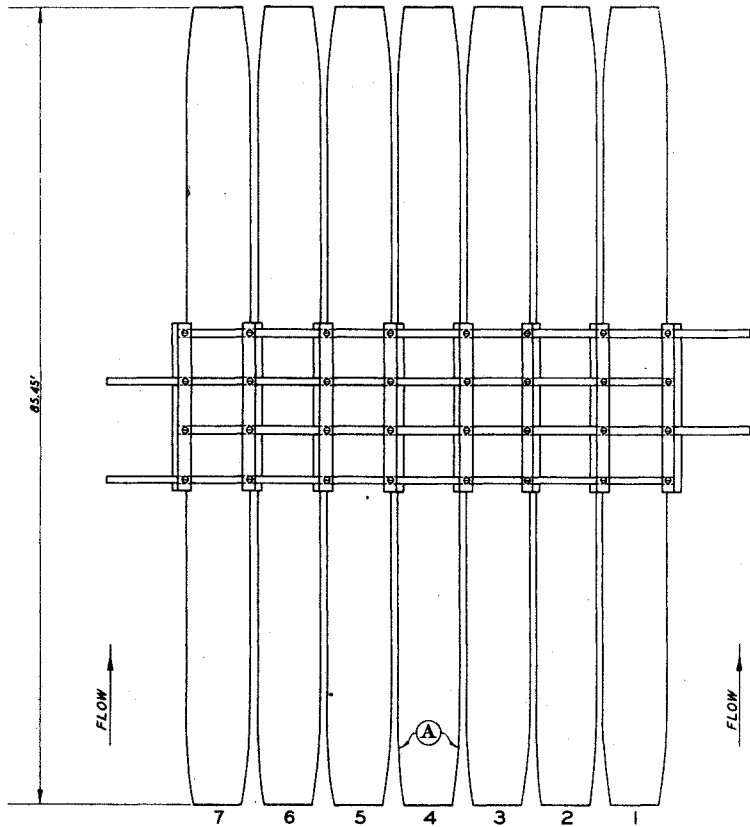

* FREEBOARD MEASUREMENTS TAKEN ALONG SIDES DENOTED BY SYMBOL (A)

TEST CONDITIONS

PONTONS ANCHORED BY LINES OVER BOW CONNECTED TO CAPSTANS.
 LENGTH OF ANCHOR LINE EQUALS 10 TIMES DEPTH OF FLOW.
 DEPTH OF FLOW EQUALS 20 FEET.
 PONTON NUMBER 4 IN THE M5 RAFT WAS LOADED IN STILL WATER
 TO 14, 10, AND 6 INCHES FREEBOARDS ON THE STARBOARD
 AND PORT SIDES, RESPECTIVELY, AT START OF TEST.

MODEL STUDY OF
 PONTONS FOR M5 BRIDGE
**AVERAGE MINIMUM FREEBOARD
 VELOCITY CURVES**
 HOLLOW "V" PONTON-SEVEN PONTON M5 RAFT



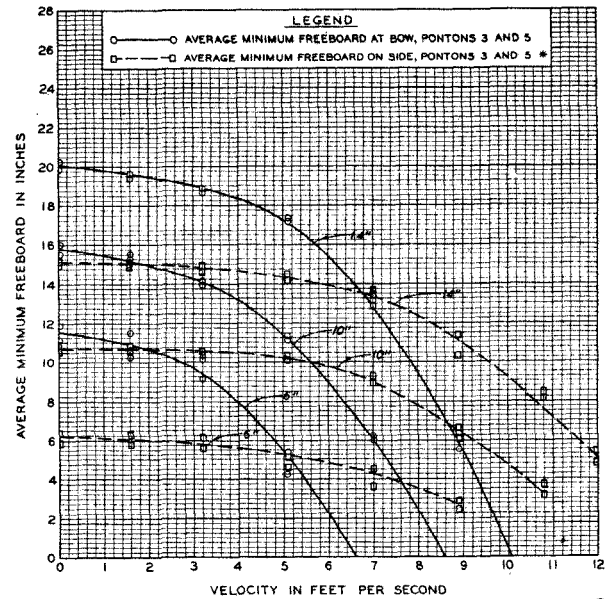
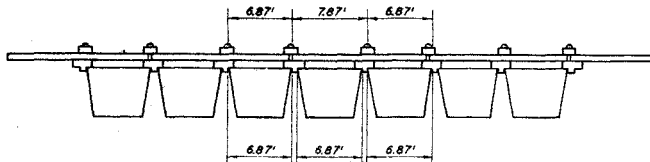
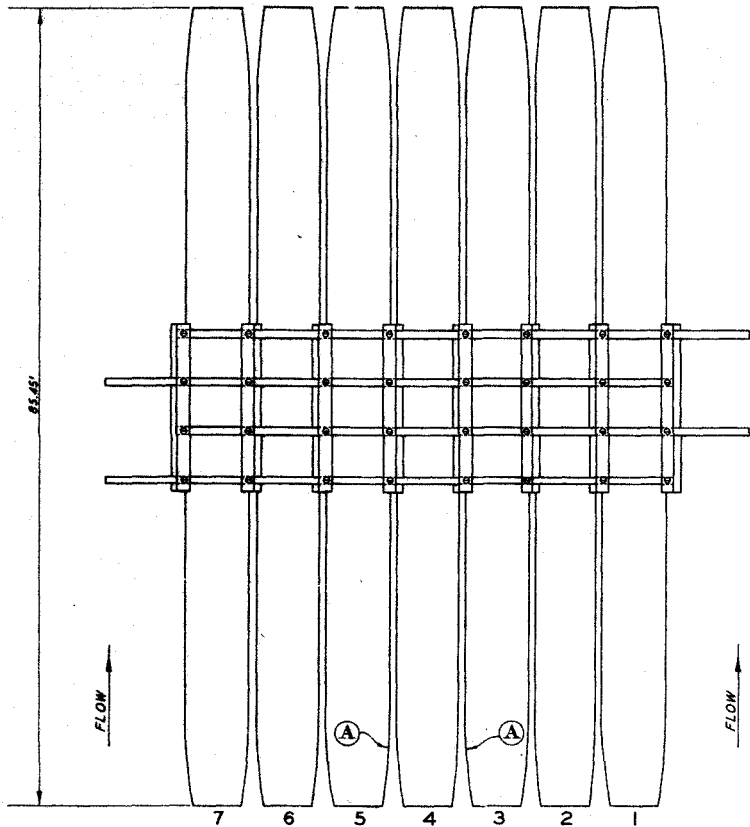

* FREEBOARD MEASUREMENTS TAKEN ALONG SIDES DENOTED BY SYMBOL (A)

TEST CONDITIONS

PONTONS ANCHORED BY LINES OVER BOW CONNECTED TO CAPSTANS. LENGTH OF ANCHOR LINE EQUALS 10 TIMES DEPTH OF FLOW. DEPTH OF FLOW EQUALS 20 FEET.

PANTON NUMBER 4 IN THE M5 RAFT WAS LOADED IN STILL WATER TO 14, 10, AND 6 INCHES FREEBOARDS ON THE STARBOARD AND PORT SIDES, RESPECTIVELY, AT START OF TEST.

MODEL STUDY OF
PONTONS FOR M5 BRIDGE
**AVERAGE MINIMUM FREEBOARD
VELOCITY CURVES**

HOLLOW "V" PANTON-SEVEN PANTON M5 RAFT

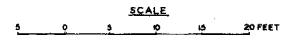

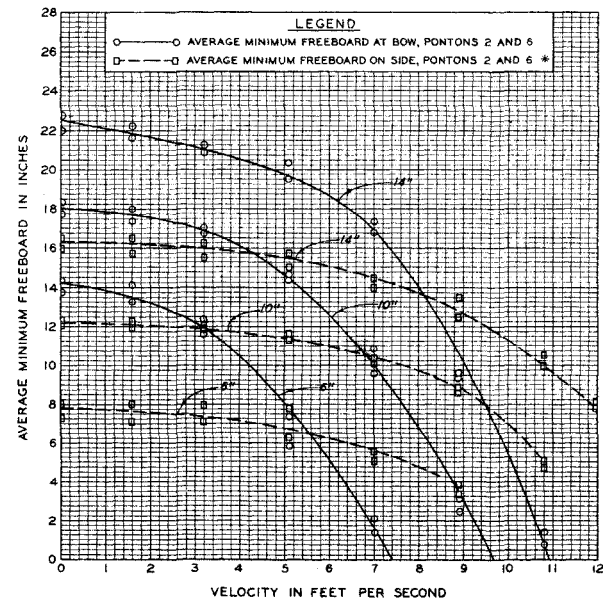
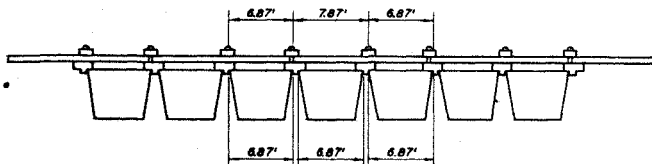
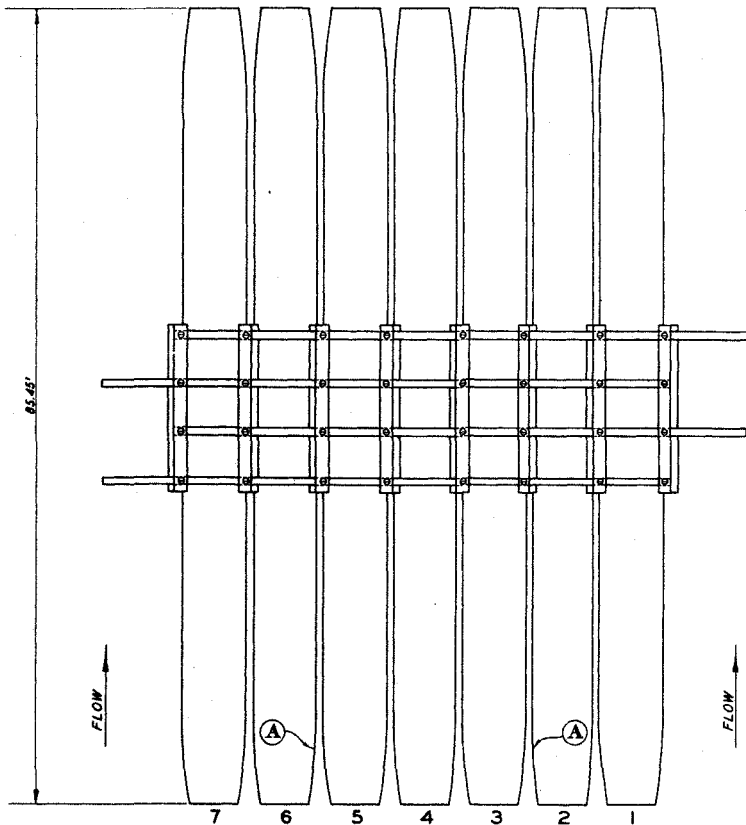

* FREEBOARD MEASUREMENTS TAKEN ALONG SIDES DENOTED BY SYMBOL (A)

TEST CONDITIONS

PONTONS ANCHORED BY LINES OVER BOW CONNECTED TO CAPSTANS.
 LENGTH OF ANCHOR LINE EQUALS 10 TIMES DEPTH OF FLOW.
 DEPTH OF FLOW EQUALS 20 FEET.
 PONTON NUMBER 4 IN THE M5 RAFT WAS LOADED IN STILL WATER
 TO 14, 10, AND 6 INCHES FREEBOARDS ON THE STARBOARD
 AND PORT SIDES, RESPECTIVELY, AT START OF TEST.

**MODEL STUDY OF
 PONTONS FOR M5 BRIDGE
 AVERAGE MINIMUM FREEBOARD
 VELOCITY CURVES**

HOLLOW "V" PONTON—SEVEN PONTON M5 RAFT

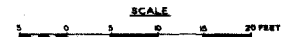

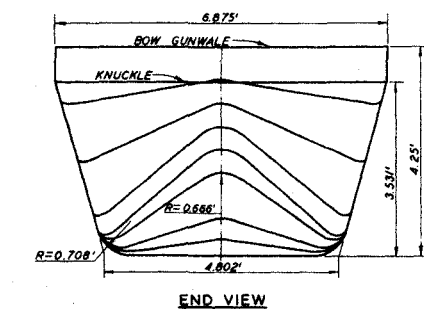
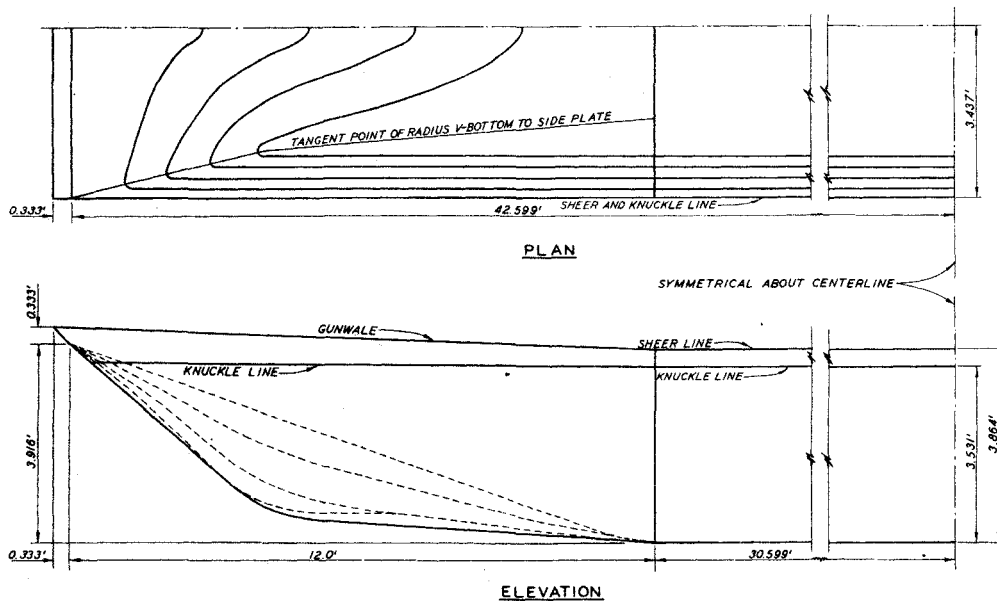

TEST CONDITIONS

PONTON LOADED IN STILL WATER TO FREEBOARDS OF 14, 10, AND 6 INCHES, RESPECTIVELY ON THE SIDE AT START OF TEST.

PONTON ANCHORED BY LINE OVER BOW CONNECTED TO CAPSTAN.

LENGTH OF ANCHOR LINE EQUALS 10 TIMES DEPTH OF FLOW.

DEPTH OF FLOW EQUALS 20 FEET.

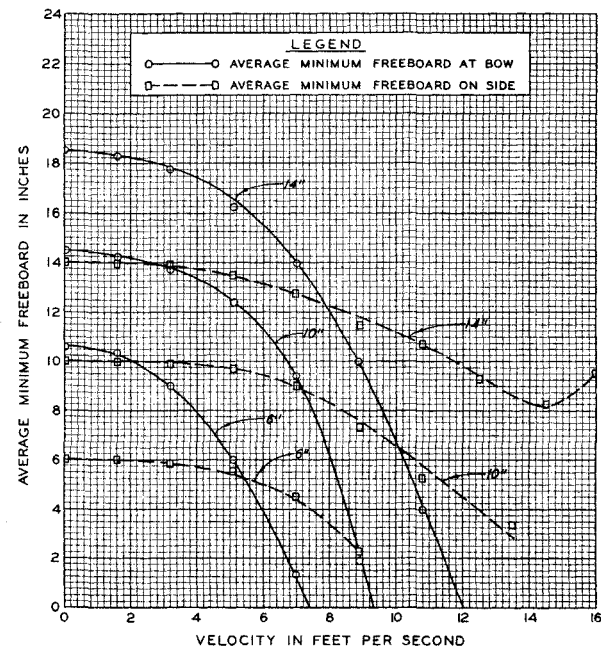

MODEL STUDY OF
PONTONS FOR M5 BRIDGE
**AVERAGE MINIMUM FREEBOARD
VELOCITY CURVES**

DOUBLE "V" PONTON-SINGLE PONTON

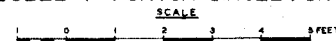

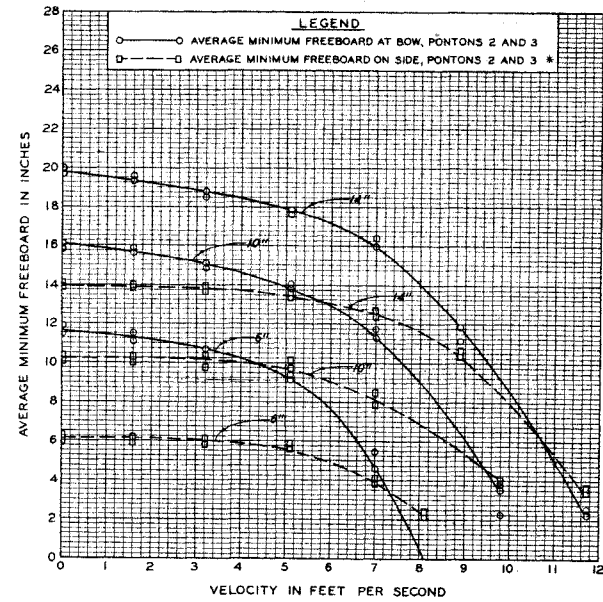
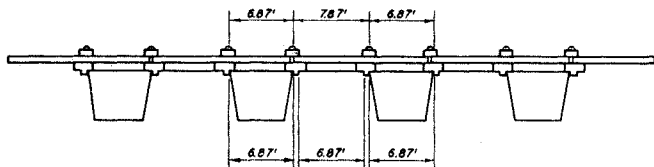
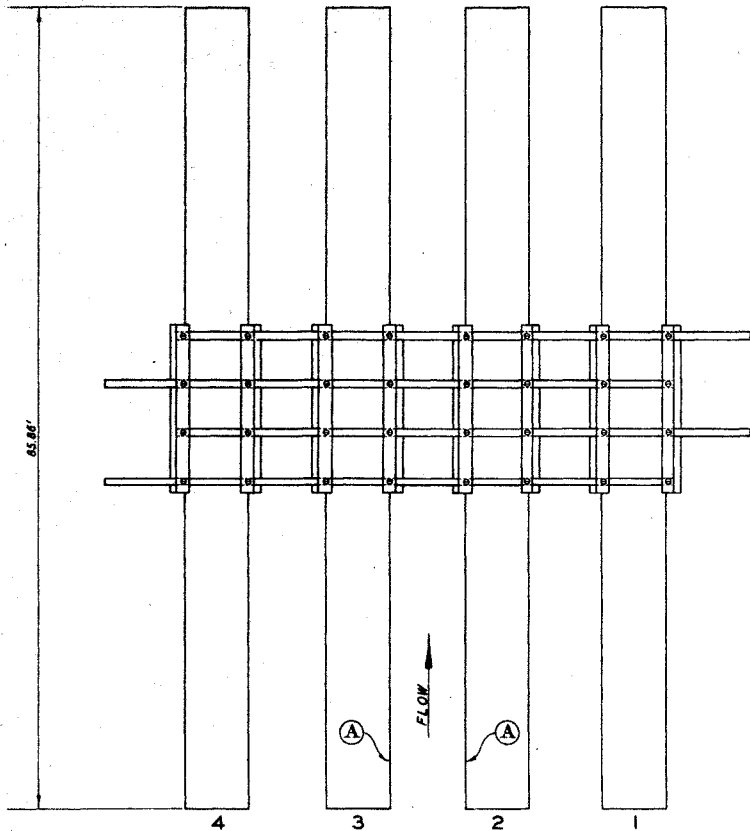

* FREEBOARD MEASUREMENTS TAKEN ALONG SIDES DENOTED BY SYMBOL (A)

TEST CONDITIONS

PONTONS ANCHORED BY LINES OVER BOW CONNECTED TO CAPSTANS.
 LENGTH OF ANCHOR LINE EQUALS 10 TIMES DEPTH OF FLOW.
 DEPTH OF FLOW EQUALS 20 FEET.
 PONTONS NUMBERS 2 AND 3 IN THE M5 RAFT WERE LOADED IN STILL WATER TO 14, 10, AND 6 INCHES FREEBOARDS ON THE STARBOARD AND PORT SIDES, RESPECTIVELY, AT START OF TEST.

MODEL STUDY OF
 PONTONS FOR M5 BRIDGE
**AVERAGE MINIMUM FREEBOARD
 VELOCITY CURVES**
 DOUBLE "V" PONTON - FOUR PONTON M5 RAFT

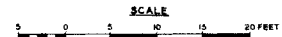

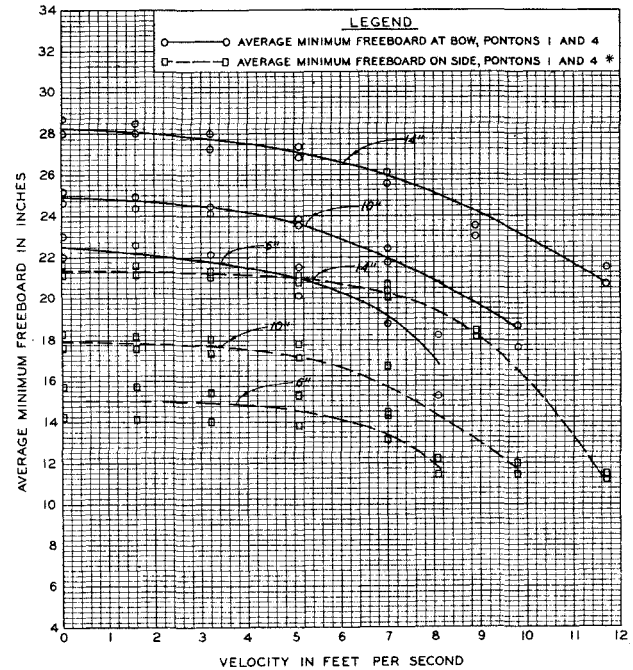
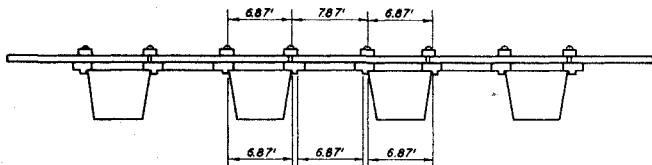
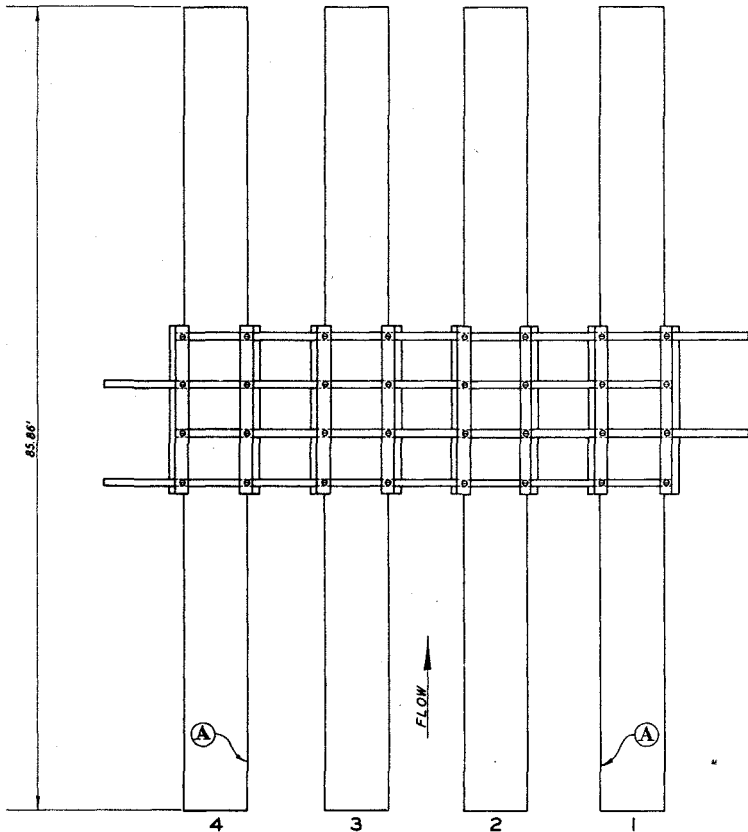

* FREEBOARD MEASUREMENTS TAKEN ALONG SIDES DENOTED BY SYMBOL (A)

TEST CONDITIONS

PONTONS ANCHORED BY LINES OVER BOW CONNECTED TO CAPSTANS.
 LENGTH OF ANCHOR LINE EQUALS 10 TIMES DEPTH OF FLOW.
 DEPTH OF FLOW EQUALS 20 FEET.
 PONTONS NUMBERS 2 AND 3 IN THE M5 RAFT WERE LOADED IN
 STILL WATER TO 14, 10, AND 6 INCHES FREEBOARDS ON THE
 STARBOARD AND PORT SIDES, RESPECTIVELY, AT START OF TEST.

MODEL STUDY OF
 PONTONS FOR M5 BRIDGE
**AVERAGE MINIMUM FREEBOARD
 VELOCITY CURVES**
 DOUBLE "V" PONTON - FOUR PONTON M5 RAFT

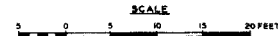

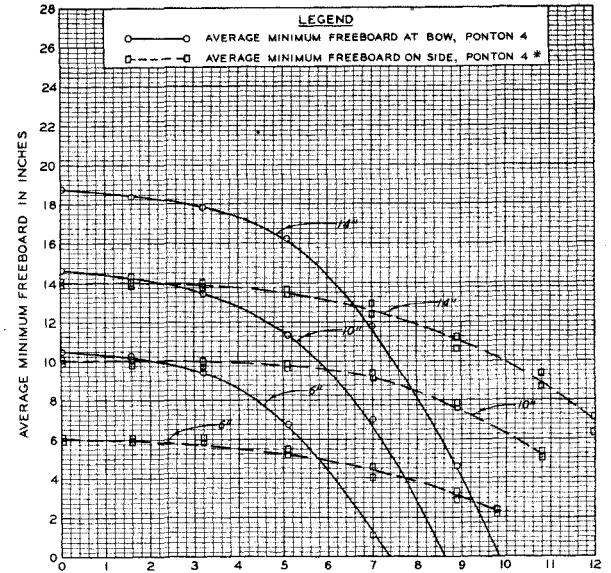
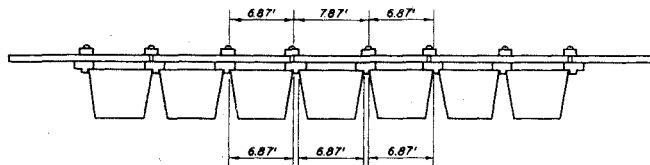
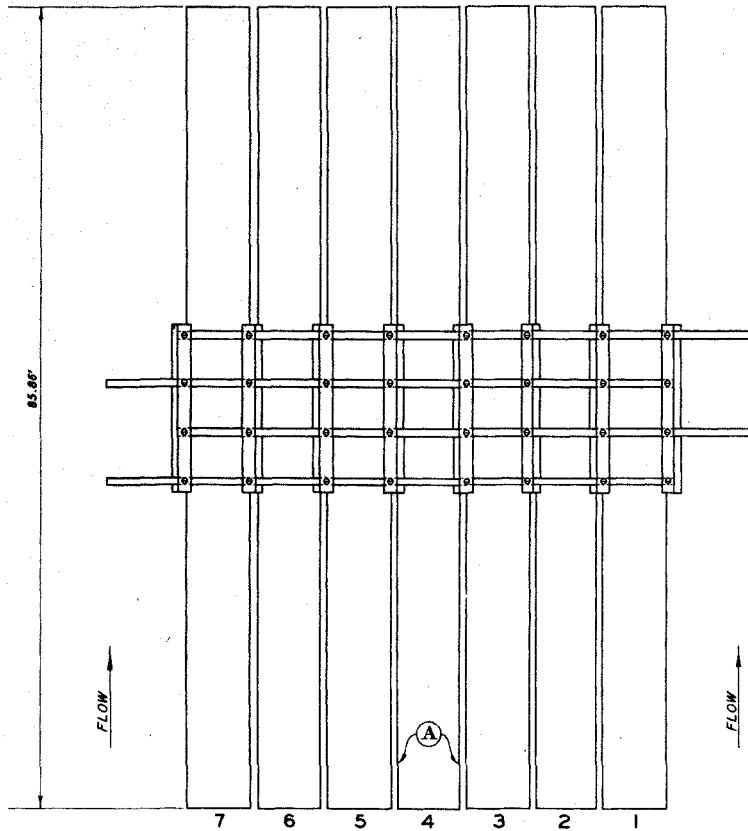

* FREEBOARD MEASUREMENTS TAKEN ALONG SIDES DENOTED BY SYMBOL (A)

TEST CONDITIONS

PONTONS ANCHORED BY LINES OVER BOW CONNECTED TO CAPSTANS. LENGTH OF ANCHOR LINE EQUALS 10 TIMES DEPTH OF FLOW. DEPTH OF FLOW EQUALS 20 FEET.

PONTON NUMBER 4 IN THE M5 RAFT WAS LOADED IN STILL WATER TO 14, 10, AND 6 INCHES FREEBOARDS ON THE STARBOARD AND PORT SIDES, RESPECTIVELY, AT START OF TEST.

MODEL STUDY OF
PONTONS FOR M5 BRIDGE
**AVERAGE MINIMUM FREEBOARD
VELOCITY CURVES**
DOUBLE "V" PONTON-SEVEN PONTON M5 RAFT

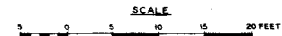

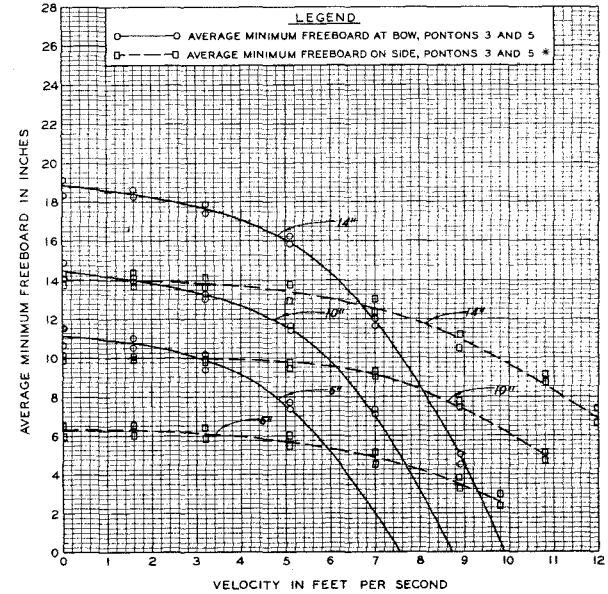
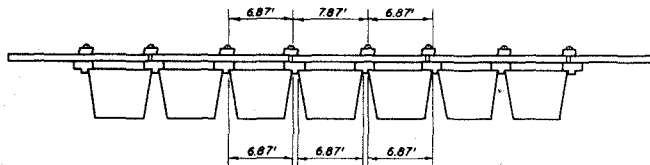
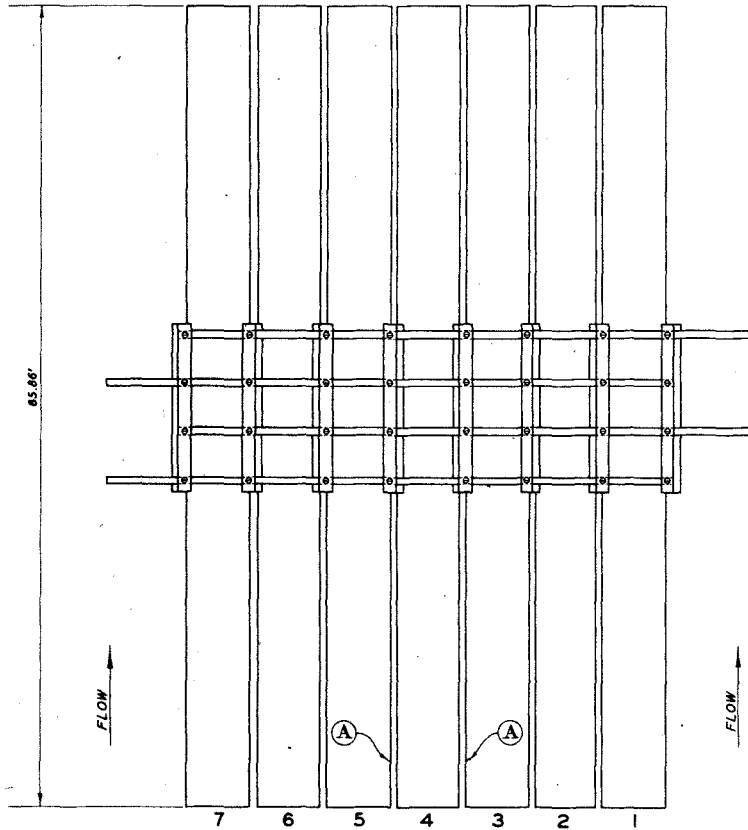

* FREEBOARD MEASUREMENTS TAKEN ALONG SIDES DENOTED BY SYMBOL (A)

TEST CONDITIONS

PONTOONS ANCHORED BY LINES OVER BOW CONNECTED TO CAPSTANS. LENGTH OF ANCHOR LINE EQUALS 10 TIMES DEPTH OF FLOW. DEPTH OF FLOW EQUALS 20 FEET.

PONTOON NUMBER 4 IN THE M5 RAFT WAS LOADED IN STILL WATER TO 14, 10, AND 6 INCHES FREEBOARDS ON THE STARBOARD AND PORT SIDES, RESPECTIVELY, AT START OF TEST.

MODEL STUDY OF
 PONTOONS FOR M5 BRIDGE
**AVERAGE MINIMUM FREEBOARD
 VELOCITY CURVES**
 DOUBLE "V" PONTOON-SEVEN PONTOON M5 RAFT



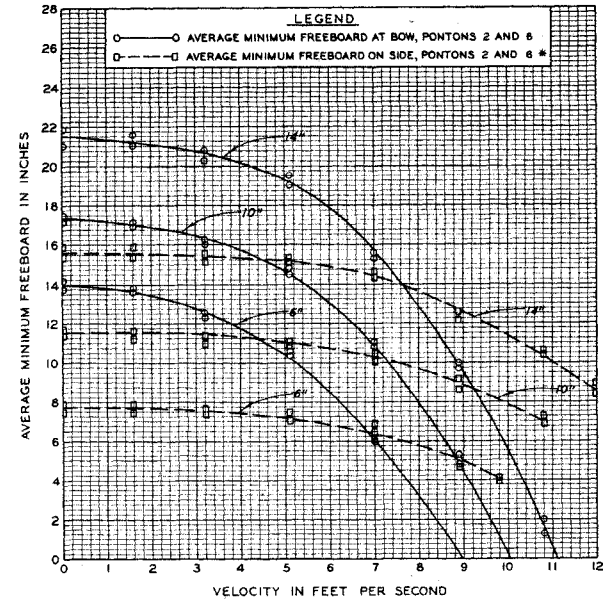
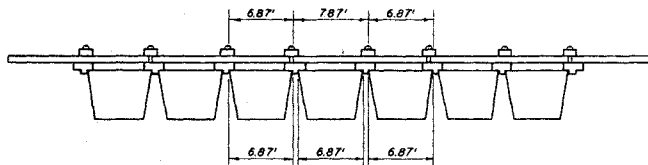
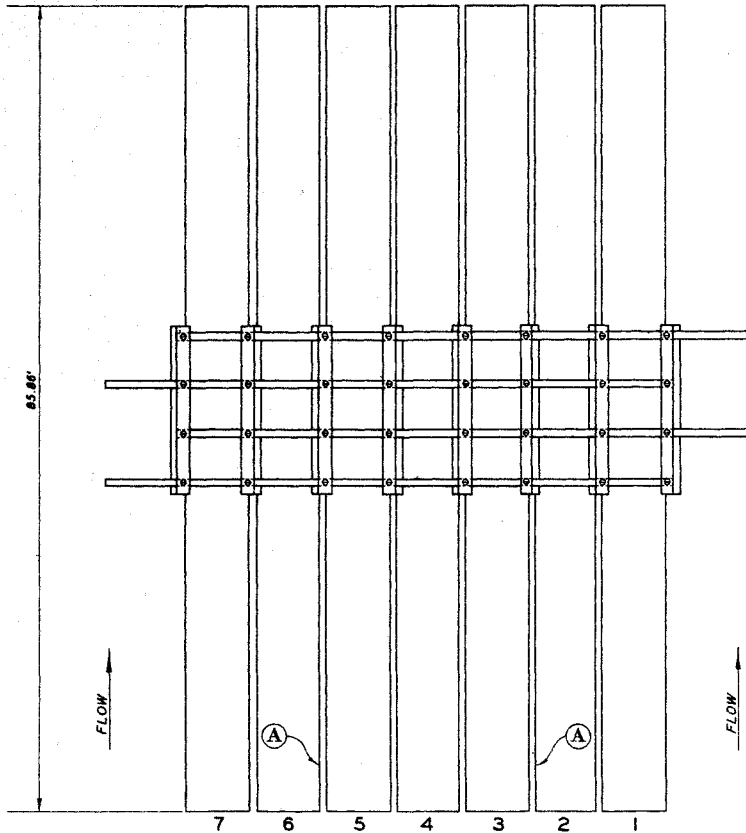

* FREEBOARD MEASUREMENTS TAKEN ALONG SIDES DENOTED BY SYMBOL (A)

TEST CONDITIONS

PONTONS ANCHORED BY LINES OVER BOW CONNECTED TO CAPSTANS. LENGTH OF ANCHOR LINE EQUALS 10 TIMES DEPTH OF FLOW. DEPTH OF FLOW EQUALS 20 FEET. PONTON NUMBER 4 IN THE M5 RAFT WAS LOADED IN STILL WATER TO 14, 10, AND 6 INCHES FREEBOARDS ON THE STARBOARD AND PORT SIDES, RESPECTIVELY, AT START OF TEST.

MODEL STUDY OF
PONTONS FOR M5 BRIDGE
**AVERAGE MINIMUM FREEBOARD
VELOCITY CURVES**
DOUBLE "V" PONTON-SEVEN PONTON M5 RAFT

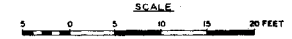

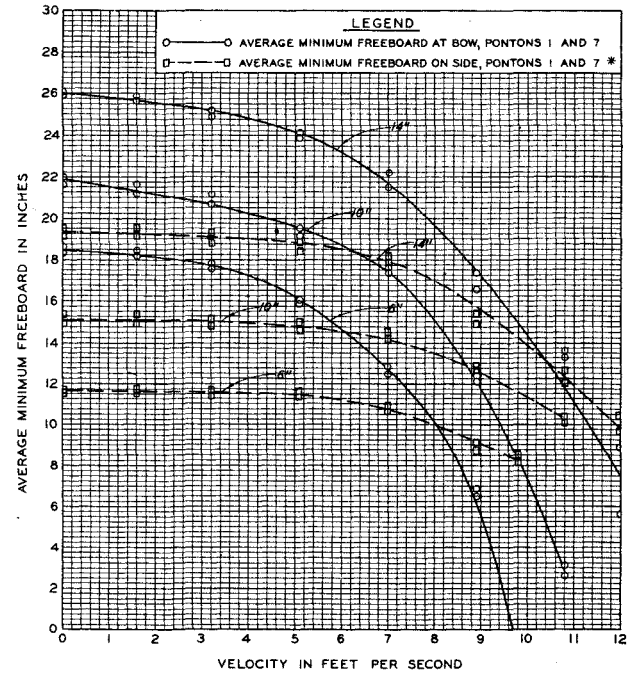
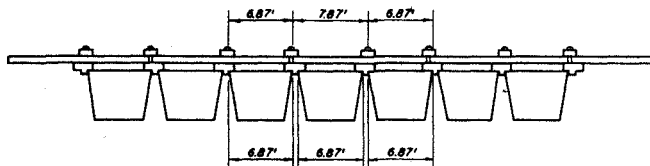
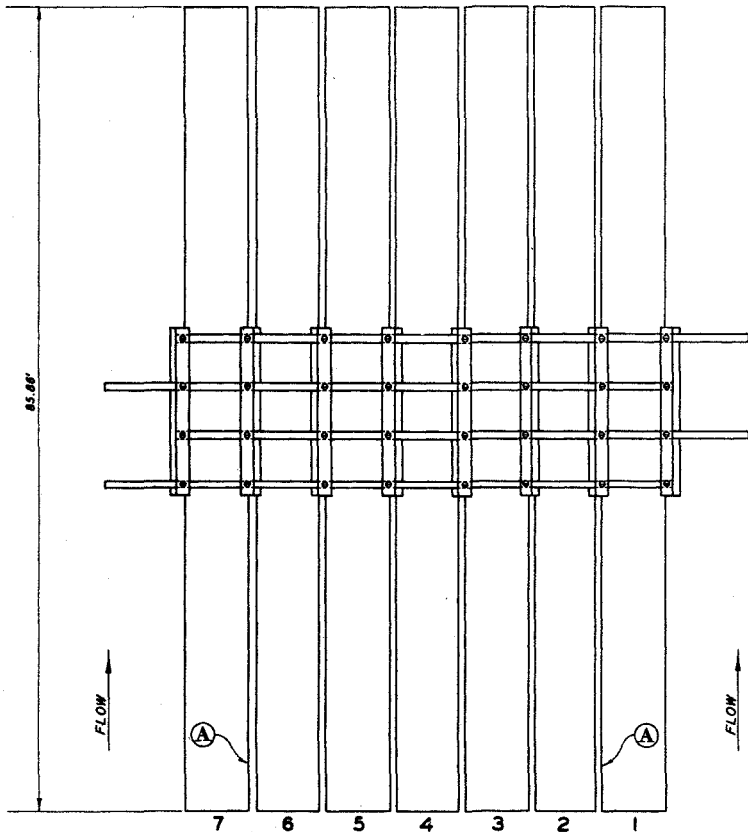

* FREEBOARD MEASUREMENTS TAKEN ALONG SIDES DENOTED BY SYMBOL (A)

TEST CONDITIONS

PONTOONS ANCHORED BY LINES OVER BOW CONNECTED TO CAPSTANS.
 LENGTH OF ANCHOR LINE EQUALS 10 TIMES DEPTH OF FLOW.
 DEPTH OF FLOW EQUALS 20 FEET.
 PONTON NUMBER 4 IN THE M5 RAFT WAS LOADED IN STILL WATER
 TO 14, 10, AND 6 INCHES FREEBOARDS ON THE STARBOARD
 AND PORT SIDES, RESPECTIVELY, AT START OF TEST.

MODEL STUDY OF
 PONTOONS FOR M5 BRIDGE
**AVERAGE MINIMUM FREEBOARD
 VELOCITY CURVES**
 DOUBLE "V" PONTON-SEVEN PONTON M5 RAFT



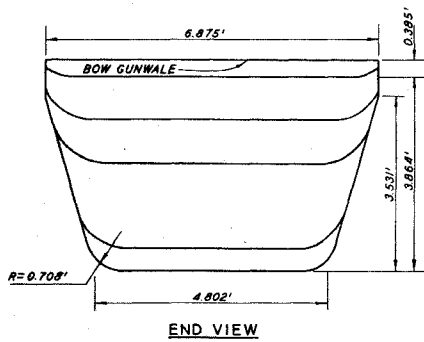
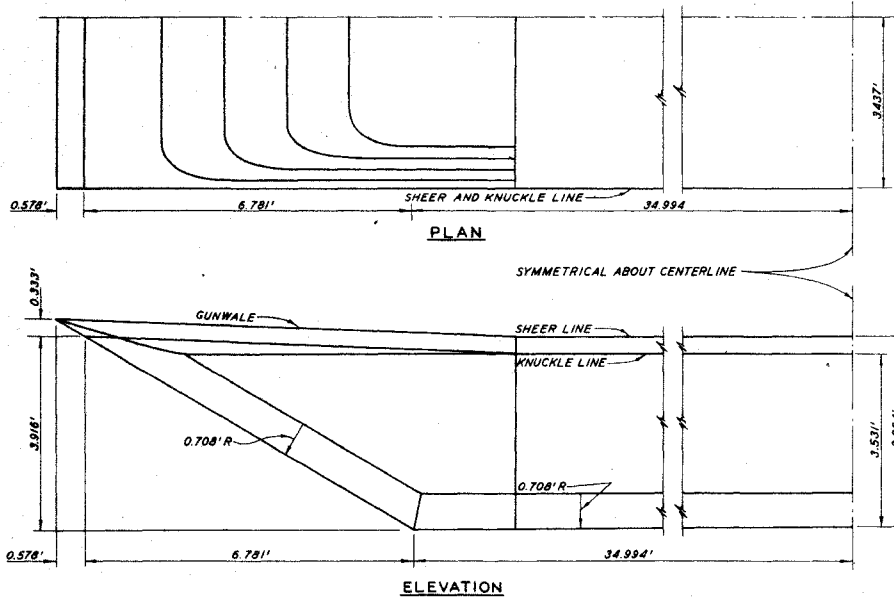

TEST CONDITIONS

- PONTON LOADED IN STILL WATER TO FREEBOARDS OF 14, 10, AND 6 INCHES, RESPECTIVELY ON THE SIDE AT START OF TEST.
- PONTON ANCHORED BY LINE OVER BOW CONNECTED TO CAPSTAN.
- LENGTH OF ANCHOR LINE EQUALS 10 TIMES DEPTH OF FLOW.
- DEPTH OF FLOW EQUALS 20 FEET.

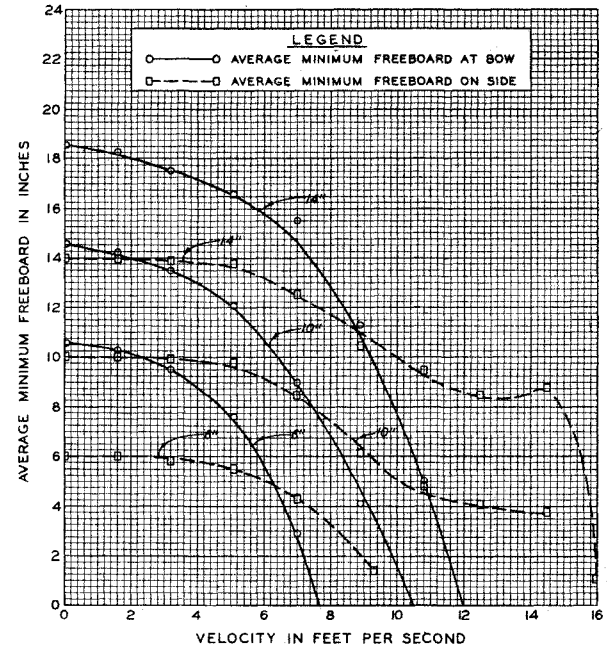

MODEL STUDY OF
PONTONS FOR M5 BRIDGE
**AVERAGE MINIMUM FREEBOARD
VELOCITY CURVES**

TYPE "A" SCOW BOW PONTON-SINGLE PONTON

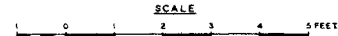

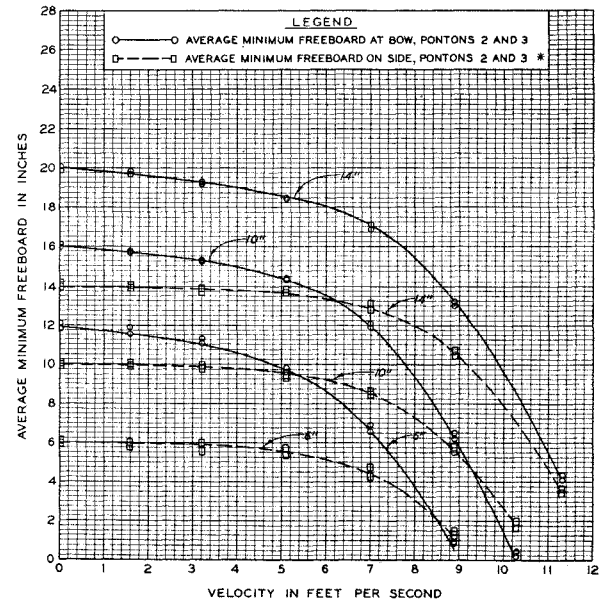
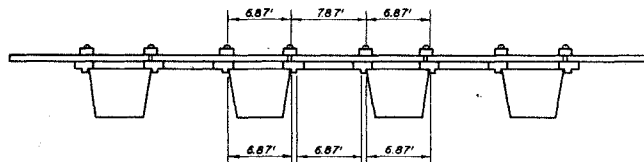
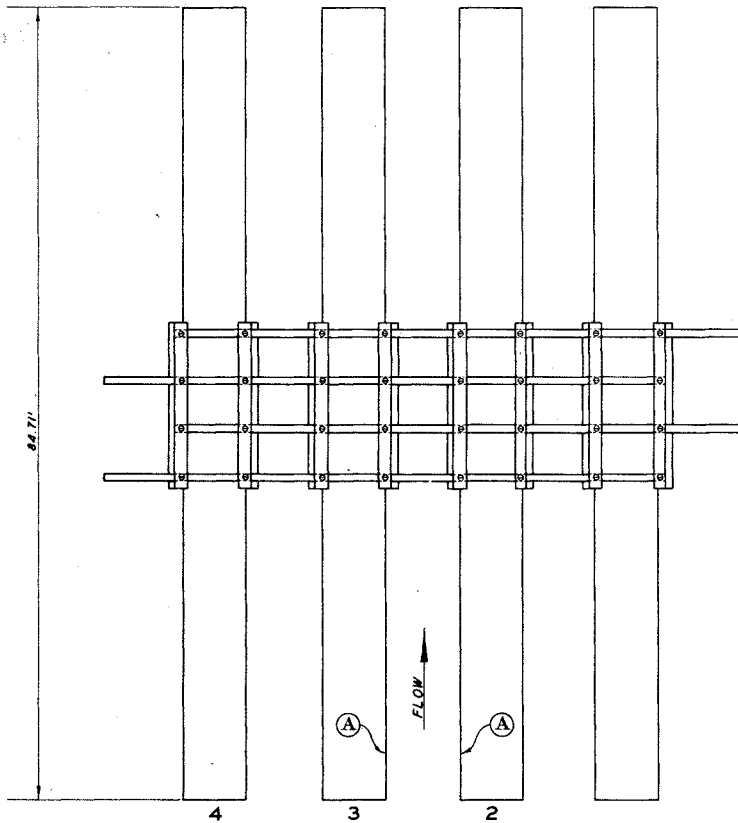

* FREEBOARD MEASUREMENTS TAKEN ALONG SIDES DENOTED BY SYMBOL (A)

TEST CONDITIONS

PONTONS ANCHORED BY LINES OVER BOW CONNECTED TO CAPSTANS.
 LENGTH OF ANCHOR LINE EQUALS 10 TIMES DEPTH OF FLOW.
 DEPTH OF FLOW EQUALS 20 FEET.
 PONTONS NUMBERS 2 AND 3 IN THE M5 RAFT WERE LOADED IN STILL WATER TO 14, 10, AND 6 INCHES FREEBOARDS ON THE STARBOARD AND PORT SIDES, RESPECTIVELY, AT START OF TEST.

MODEL STUDY OF
 PONTONS FOR M5 BRIDGE
**AVERAGE MINIMUM FREEBOARD
 VELOCITY CURVES**
 TYPE "A" SCOW BOW PONTON-FOUR PONTON M5 RAFT

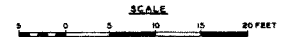

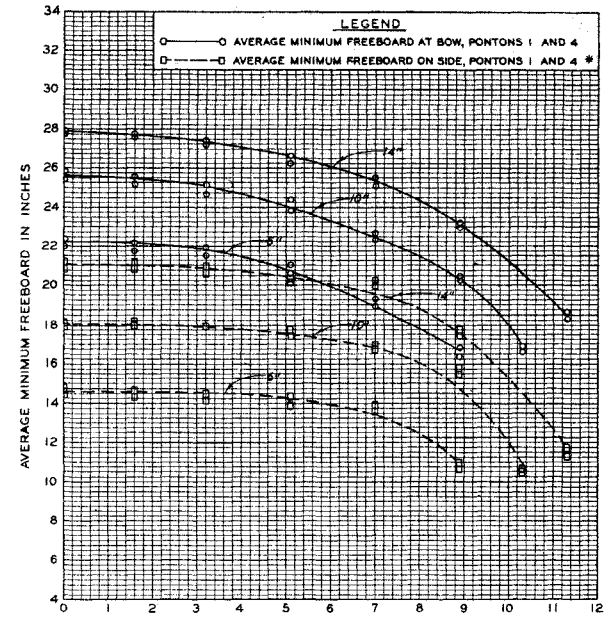
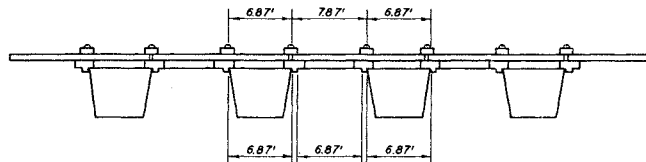
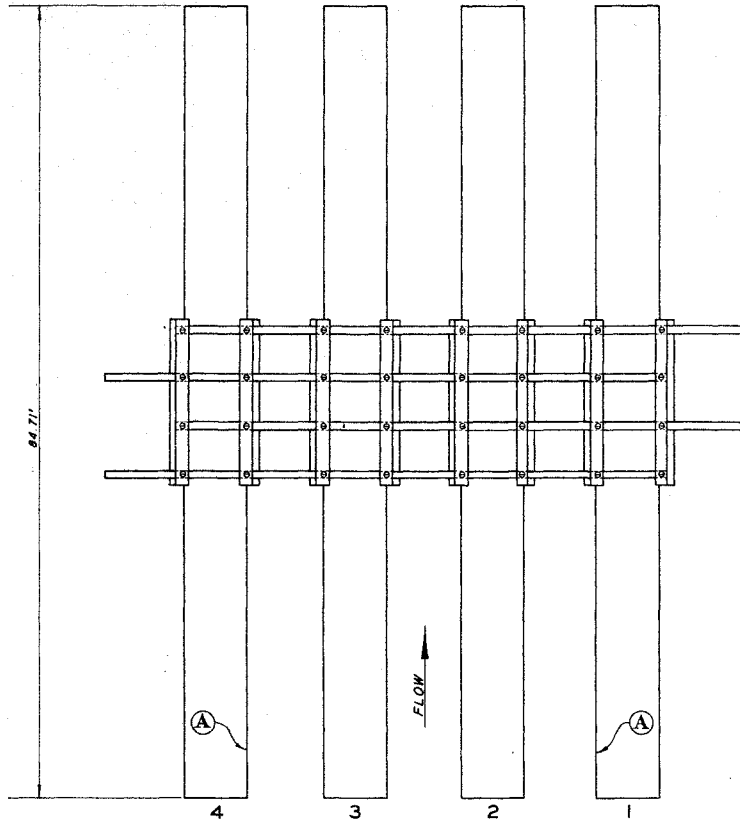

* FREEBOARD MEASUREMENTS TAKEN ALONG SIDES DENOTED BY SYMBOL (A)

TEST CONDITIONS

PONTONS ANCHORED BY LINES OVER BOW CONNECTED TO CAPSTANS.
 LENGTH OF ANCHOR LINE EQUALS 10 TIMES DEPTH OF FLOW.
 DEPTH OF FLOW EQUALS 20 FEET.
 PONTONS NUMBERS 2 AND 3 IN THE M5 RAFT WERE LOADED IN STILL WATER TO 14, 10, AND 6 INCHES FREEBOARDS ON THE STARBOARD AND PORT SIDES, RESPECTIVELY, AT START OF TEST.

MODEL STUDY OF
 PONTONS FOR M5 BRIDGE
**AVERAGE MINIMUM FREEBOARD
 VELOCITY CURVES**

TYPE "A" SCOW BOW PONTON-FOUR PONTON M5 RAFT

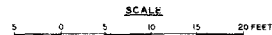

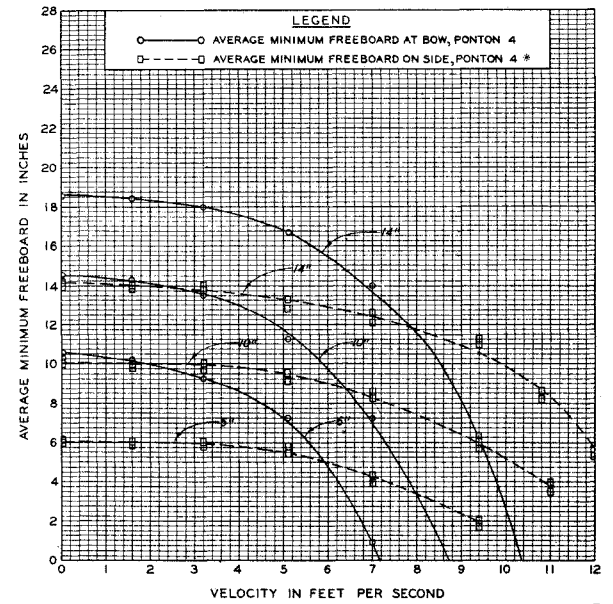
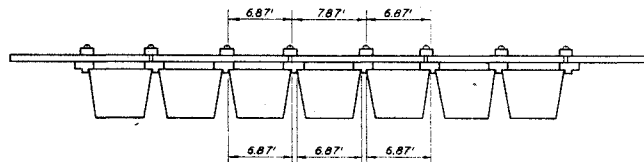
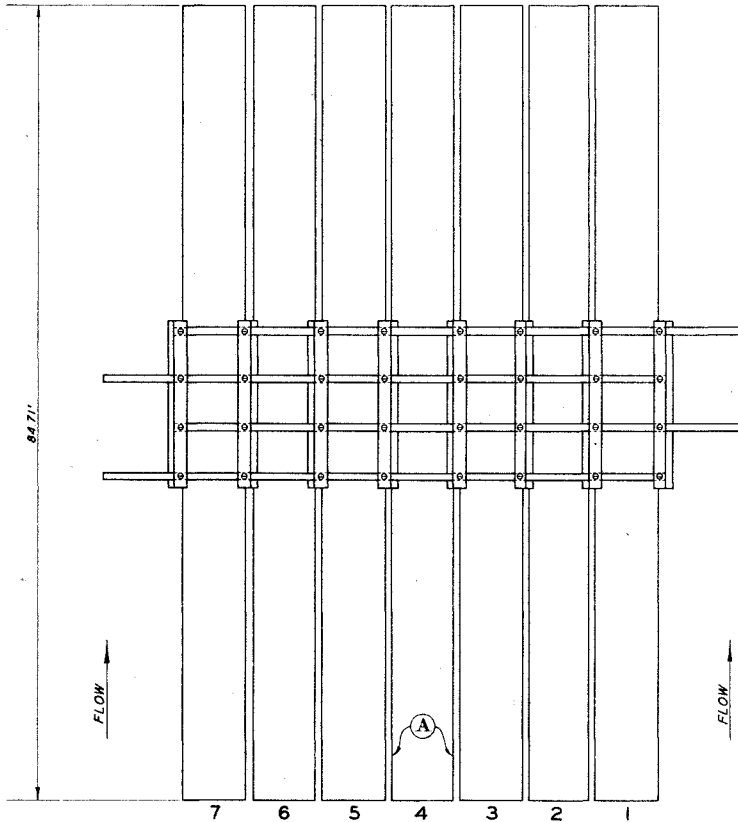

* FREEBOARD MEASUREMENTS TAKEN ALONG SIDES DENOTED BY SYMBOL (A)

TEST CONDITIONS

PONTOONS ANCHORED BY LINES OVER BOW CONNECTED TO CAPSTANS.
 LENGTH OF ANCHOR LINE EQUALS 10 TIMES DEPTH OF FLOW.
 DEPTH OF FLOW EQUALS 20 FEET.
 PONTON NUMBER 4 IN THE M5 RAFT WAS LOADED IN STILL WATER
 TO 14, 10, AND 6 INCHES FREEBOARDS ON THE STARBOARD
 AND PORT SIDES, RESPECTIVELY, AT START OF TEST.

MODEL STUDY OF
 PONTOONS FOR M5 BRIDGE
**AVERAGE MINIMUM FREEBOARD
 VELOCITY CURVES**
 TYPE "A" SCOW BOW PONTON-SEVEN PONTON M5 RAFT

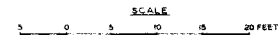

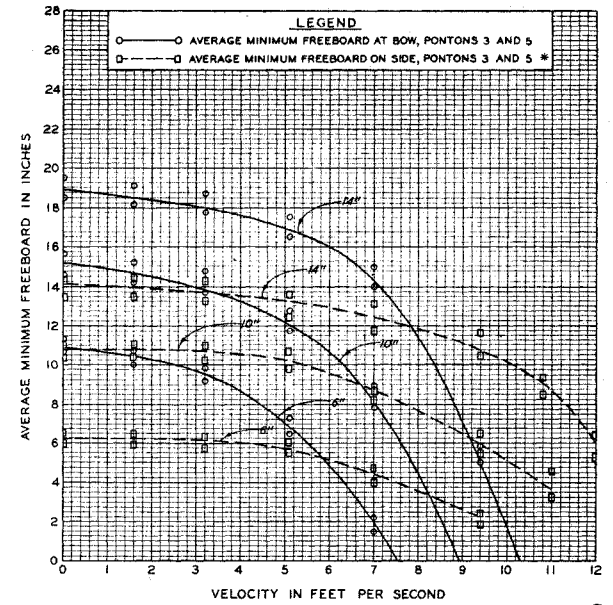
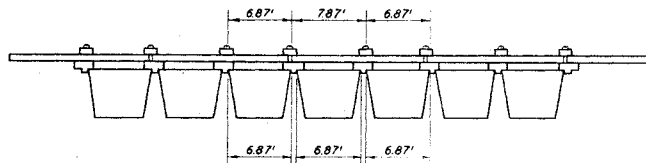
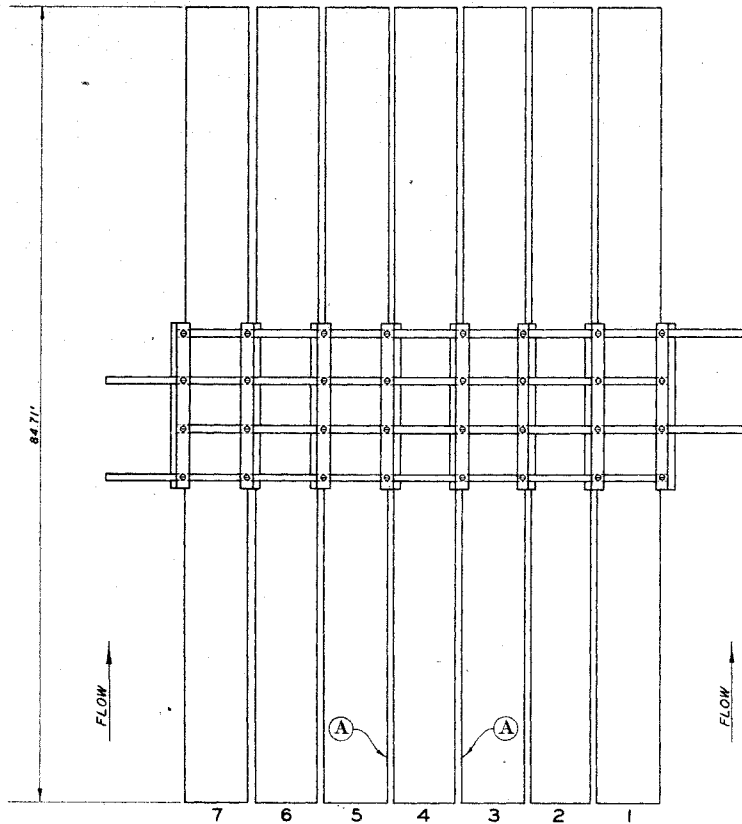

* FREEBOARD MEASUREMENTS TAKEN ALONG SIDES DENOTED BY SYMBOL (A)

TEST CONDITIONS

PONTONS ANCHORED BY LINES OVER BOW CONNECTED TO CAPSTANS.
 LENGTH OF ANCHOR LINE EQUALS 10 TIMES DEPTH OF FLOW.
 DEPTH OF FLOW EQUALS 20 FEET.
 PONTON NUMBER 4 IN THE M5 RAFT WAS LOADED IN STILL WATER
 TO 14, 10, AND 6 INCHES FREEBOARDS ON THE STARBOARD
 AND PORT SIDES, RESPECTIVELY, AT START OF TEST.

MODEL STUDY OF
 PONTONS FOR M5 BRIDGE
**AVERAGE MINIMUM FREEBOARD
 VELOCITY CURVES**
 TYPE "A" SCOW BOW PONTON-SEVEN PONTON M5 RAFT

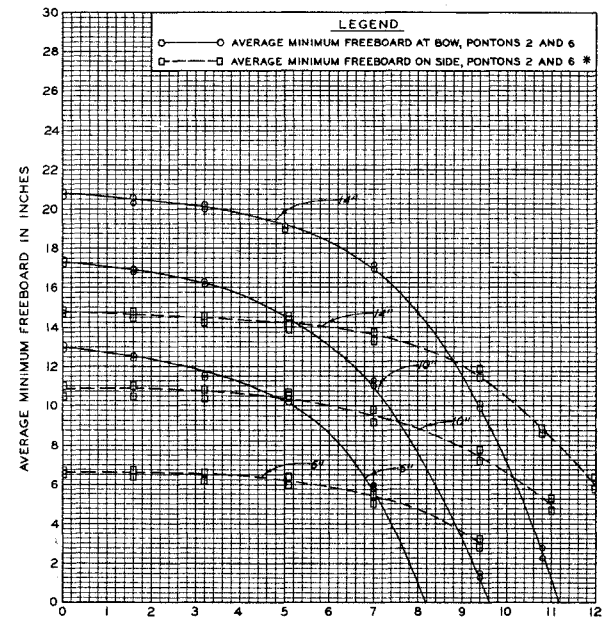
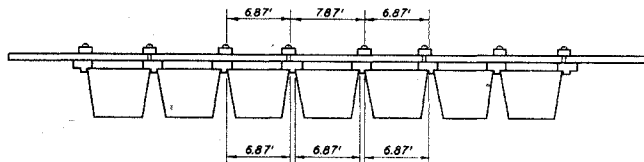
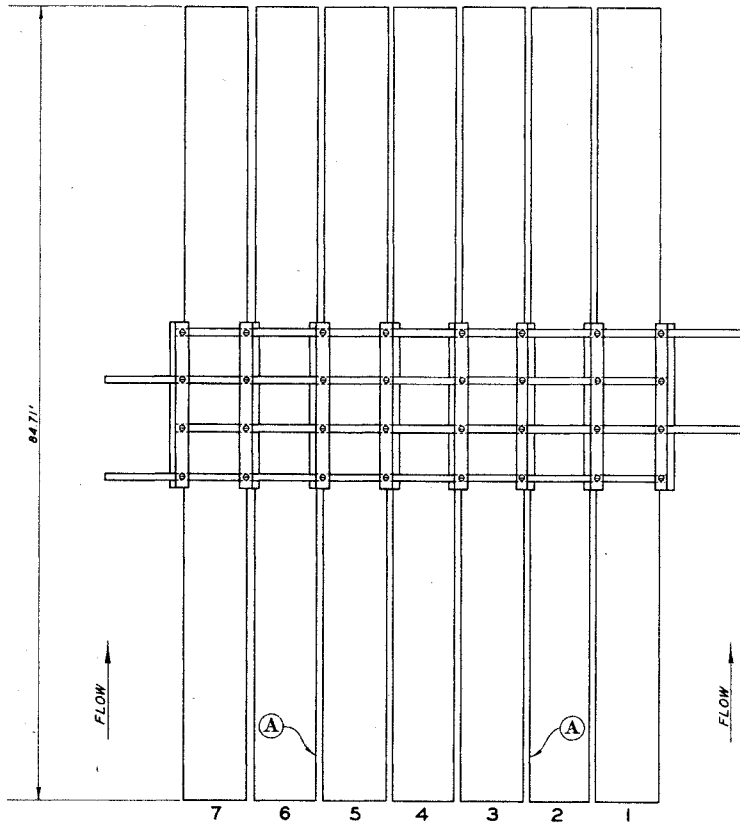

* FREEBOARD MEASUREMENTS TAKEN ALONG SIDES DENOTED BY SYMBOL (A)

TEST CONDITIONS

PONTONS ANCHORED BY LINES OVER BOW CONNECTED TO CAPSTANS.
 LENGTH OF ANCHOR LINE EQUALS 10 TIMES DEPTH OF FLOW.
 DEPTH OF FLOW EQUALS 20 FEET.
 PONTON NUMBER 4 IN THE M5 RAFT WAS LOADED IN STILL WATER
 TO 14, 10, AND 6 INCHES FREEBOARDS ON THE STARBOARD
 AND PORT SIDES, RESPECTIVELY, AT START OF TEST.

MODEL STUDY OF
 PONTONS FOR M5 BRIDGE
**AVERAGE MINIMUM FREEBOARD
 VELOCITY CURVES**

TYPE "A" SCOW BOW PONTON-SEVEN PONTON M5 RAFT

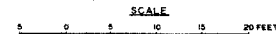

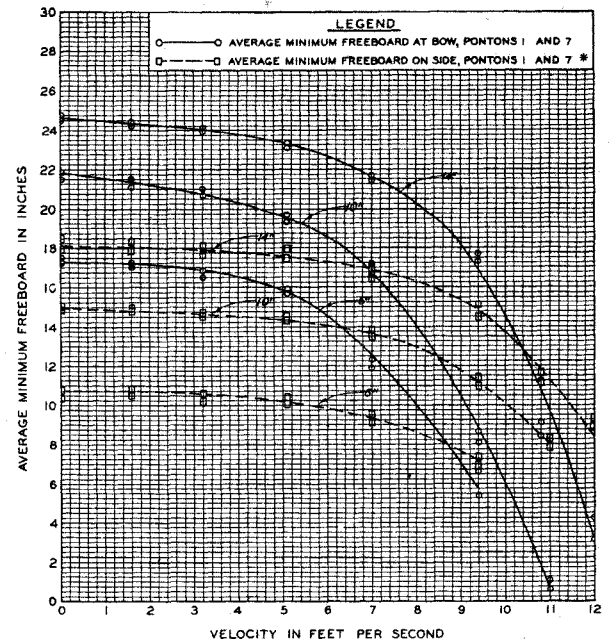
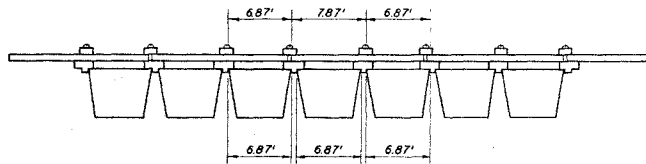
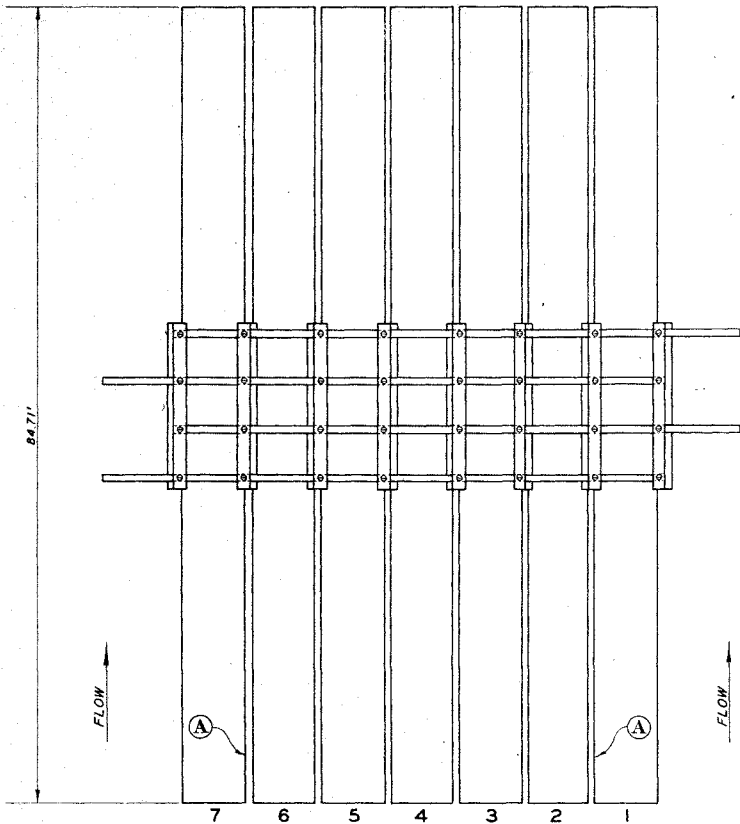

* FREEBOARD MEASUREMENTS TAKEN ALONG SIDES DENOTED BY SYMBOL (A)

TEST CONDITIONS

PONTOONS ANCHORED BY LINES OVER BOW CONNECTED TO CAPSTANS.
 LENGTH OF ANCHOR LINE EQUALS 10 TIMES DEPTH OF FLOW.
 DEPTH OF FLOW EQUALS 20 FEET.

PONTOON NUMBER 4 IN THE M5 RAFT WAS LOADED IN STILL WATER
 TO 14, 10, AND 6 INCHES FREEBOARDS ON THE STARBOARD
 AND PORT SIDES, RESPECTIVELY, AT START OF TEST.

MODEL STUDY OF
 PONTOONS FOR M5 BRIDGE
**AVERAGE MINIMUM FREEBOARD
 VELOCITY CURVES**
 TYPE "A" SCOW BOW PONTOON-SEVEN PONTOON M5 RAFT

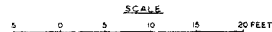

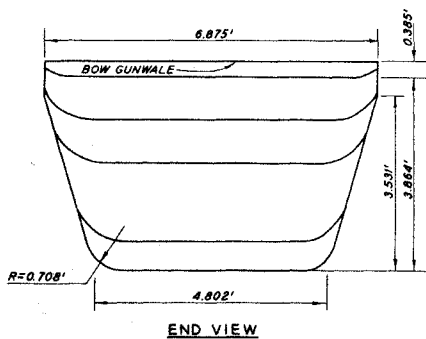
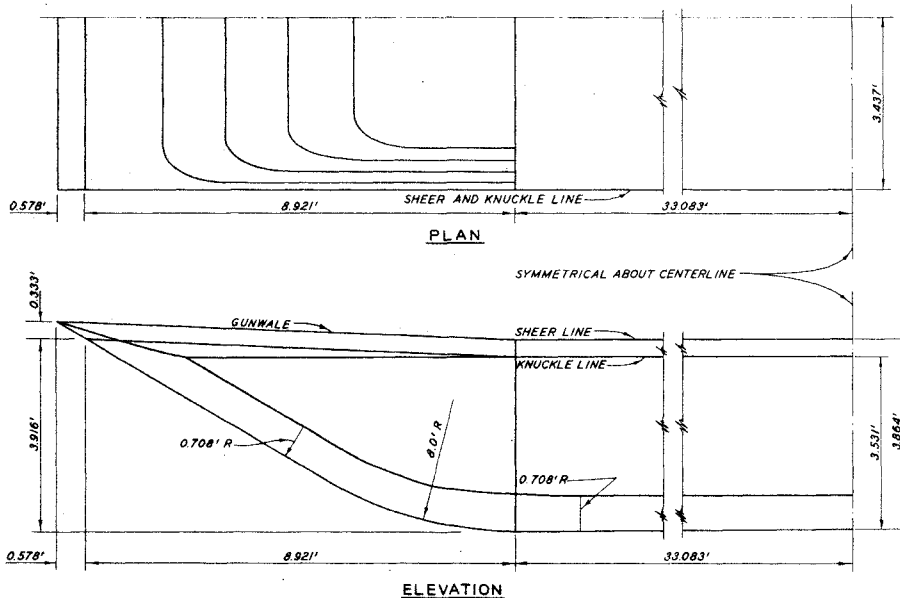

TEST CONDITIONS

PONTON LOADED IN STILL WATER TO FREEBOARDS OF 14, 10, AND 6 INCHES, RESPECTIVELY ON THE SIDE AT START OF TEST.

PONTON ANCHORED BY LINE OVER BOW CONNECTED TO CAPSTAN.

LENGTH OF ANCHOR LINE EQUALS 10 TIMES DEPTH OF FLOW.

DEPTH OF FLOW EQUALS 20 FEET.

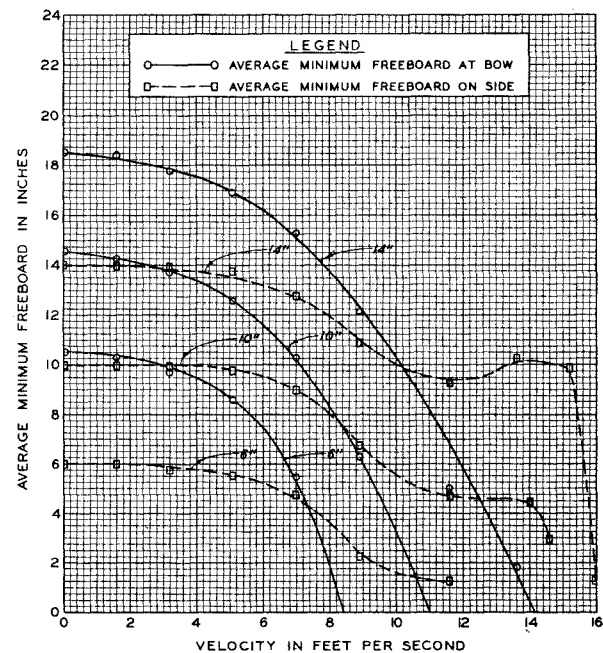

MODEL STUDY OF
PONTONS FOR M5 BRIDGE
**AVERAGE MINIMUM FREEBOARD
VELOCITY CURVES**

TYPE "B" SCOW BOW PONTON-SINGLE PONTON

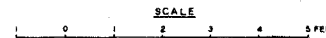

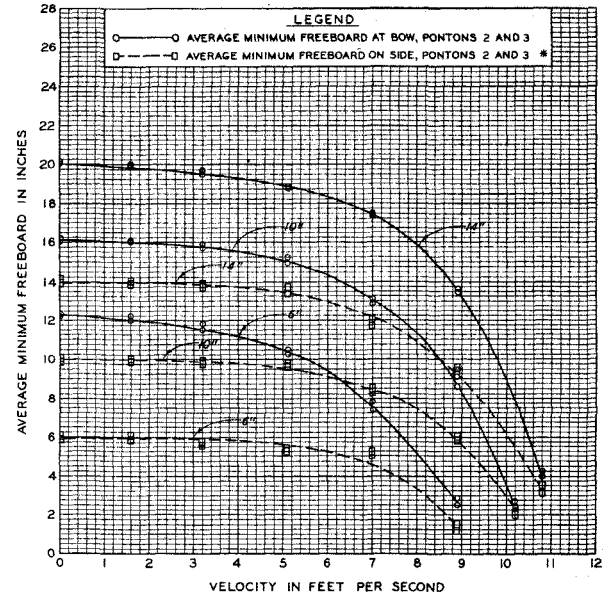
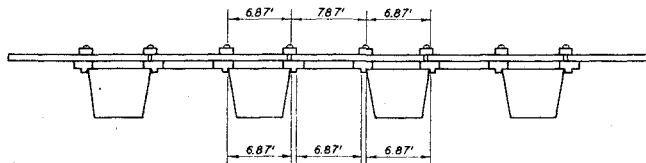
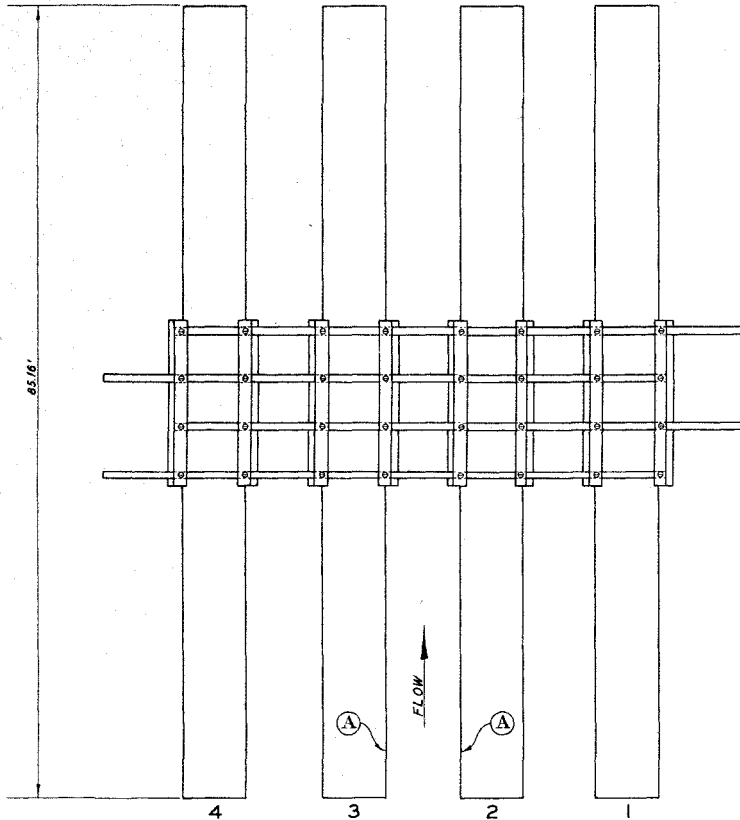

* FREEBOARD MEASUREMENTS TAKEN ALONG SIDES DENOTED BY SYMBOL (A)

TEST CONDITIONS

PONTONS ANCHORED BY LINES OVER BOW CONNECTED TO CAPSTANS.
 LENGTH OF ANCHOR LINE EQUALS 10 TIMES DEPTH OF FLOW.
 DEPTH OF FLOW EQUALS 20 FEET.
 PONTONS NUMBERS 2 AND 3 IN THE M5 RAFT WERE LOADED IN STILL WATER TO 14, 10, AND 6 INCHES FREEBOARDS ON THE STARBOARD AND PORT SIDES, RESPECTIVELY, AT START OF TEST.

MODEL STUDY OF
 PONTONS FOR M5 BRIDGE
**AVERAGE MINIMUM FREEBOARD
 VELOCITY CURVES**

TYPE "B" SCOW BOW PONTON-FOUR PONTON M5 RAFT

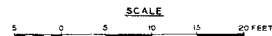

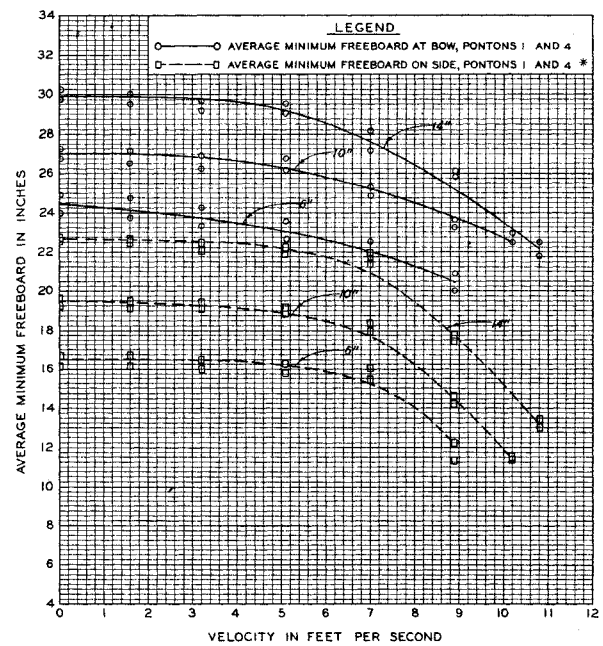
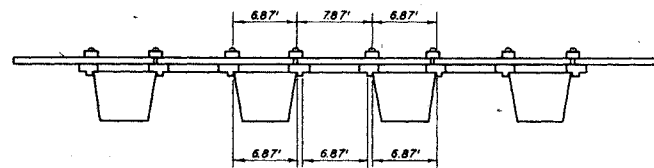
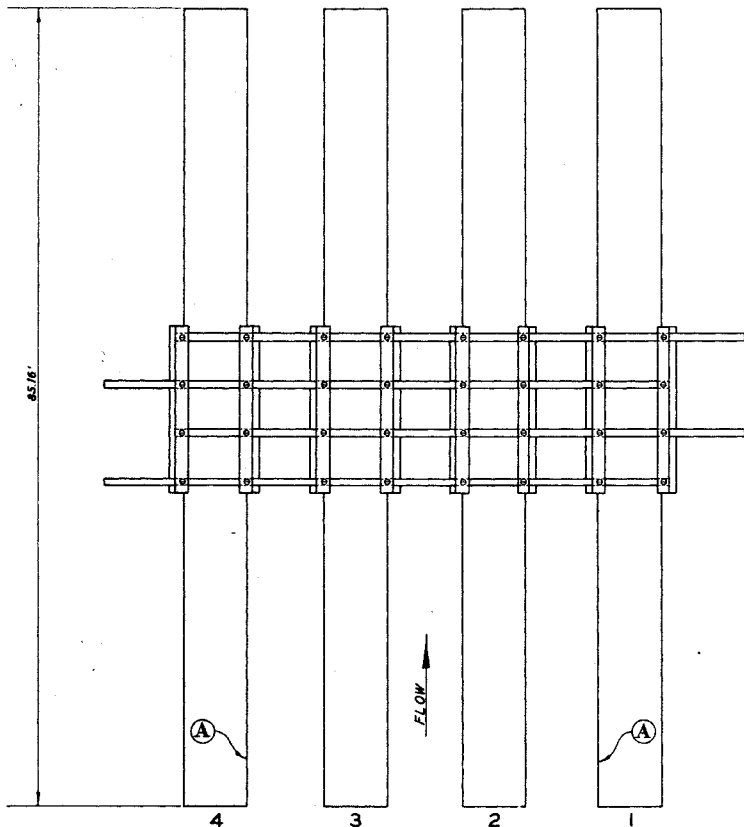

* FREEBOARD MEASUREMENTS TAKEN ALONG SIDES DENOTED BY SYMBOL (A)

TEST CONDITIONS

PONTONS ANCHORED BY LINES OVER BOW CONNECTED TO CAPSTANS.
 LENGTH OF ANCHOR LINE EQUALS 10 TIMES DEPTH OF FLOW.
 DEPTH OF FLOW EQUALS 20 FEET.
 PONTONS NUMBERS 2 AND 3 IN THE M5 RAFT WERE LOADED IN STILL WATER TO 14, 10, AND 6 INCHES FREEBOARDS ON THE STARBOARD AND PORT SIDES, RESPECTIVELY, AT START OF TEST.

MODEL STUDY OF
 PONTONS FOR M5 BRIDGE
**AVERAGE MINIMUM FREEBOARD
 VELOCITY CURVES**
 TYPE 'B' SCOW BOW PONTON-FOUR PONTON M5 RAFT

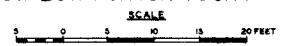

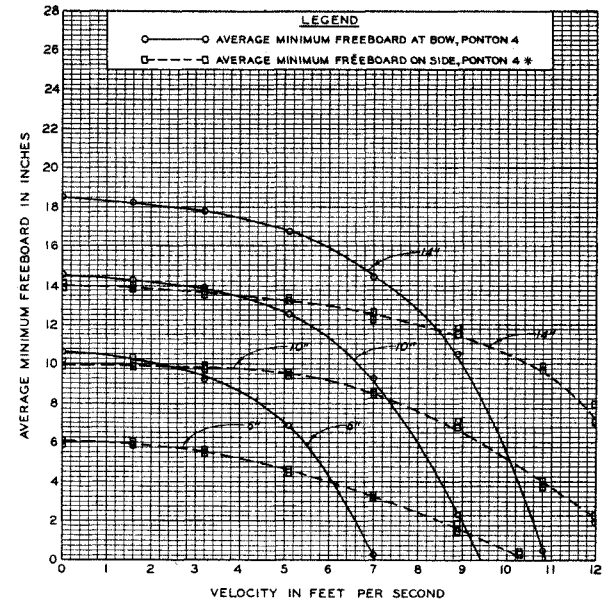
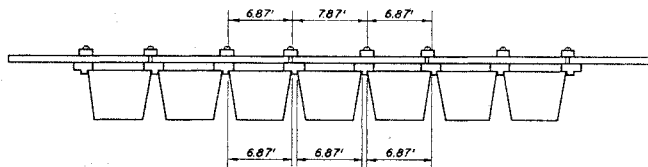
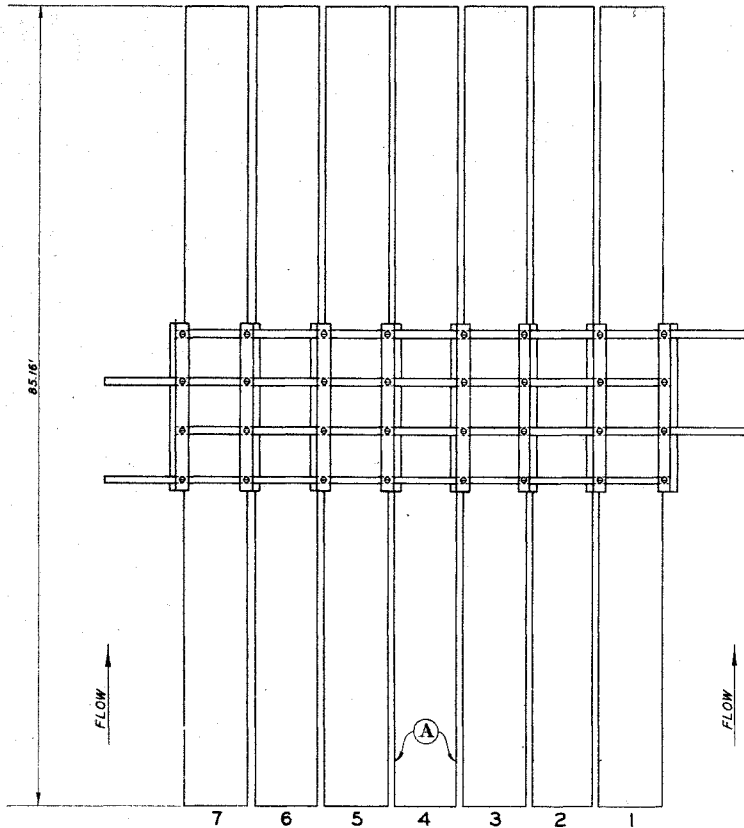

* FREEBOARD MEASUREMENTS TAKEN ALONG SIDES DENOTED BY SYMBOL (A)

TEST CONDITIONS

PONTONS ANCHORED BY LINES OVER BOW CONNECTED TO CAPSTANS.
 LENGTH OF ANCHOR LINE EQUALS 10 TIMES DEPTH OF FLOW.
 DEPTH OF FLOW EQUALS 20 FEET.
 PONTON NUMBER 4 IN THE M5 RAFT WAS LOADED IN STILL WATER
 TO 14, 10, AND 6 INCHES FREEBOARDS ON THE STARBOARD
 AND PORT SIDES, RESPECTIVELY, AT START OF TEST.

MODEL STUDY OF
 PONTONS FOR M5 BRIDGE
**AVERAGE MINIMUM FREEBOARD
 VELOCITY CURVES**

TYPE "B" SCOW BOW PONTON—SEVEN PONTON M5 RAFT

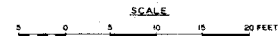

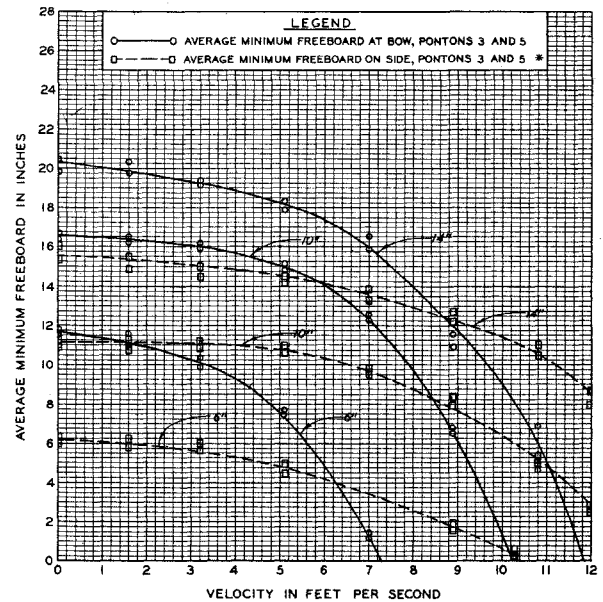
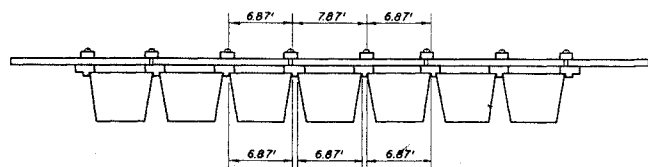
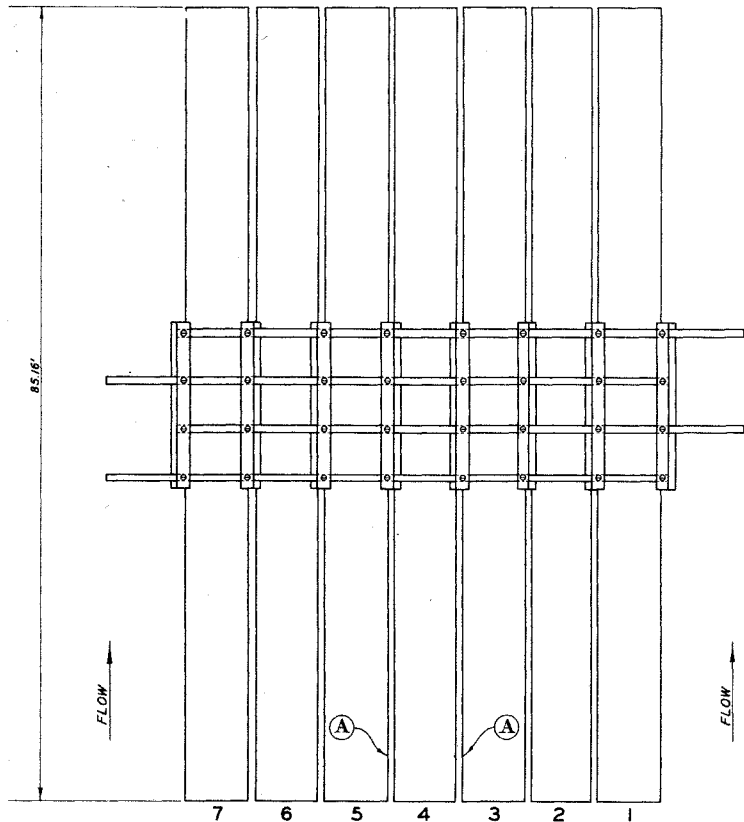

* FREEBOARD MEASUREMENTS TAKEN ALONG SIDES DENOTED BY SYMBOL (A)

TEST CONDITIONS

PONTONS ANCHORED BY LINES OVER BOW CONNECTED TO CAPSTANS.
 LENGTH OF ANCHOR LINE EQUALS 10 TIMES DEPTH OF FLOW.
 DEPTH OF FLOW EQUALS 20 FEET.
 PONTON NUMBER 4 IN THE M5 RAFT WAS LOADED IN STILL WATER
 TO 14, 10, AND 6 INCHES FREEBOARDS ON THE STARBOARD
 AND PORT SIDES, RESPECTIVELY, AT START OF TEST.

MODEL STUDY OF
 PONTONS FOR M5 BRIDGE
**AVERAGE MINIMUM FREEBOARD
 VELOCITY CURVES**

TYPE "B" SCOW BOW PONTON-SEVEN PONTON M5 RAFT

SCALE



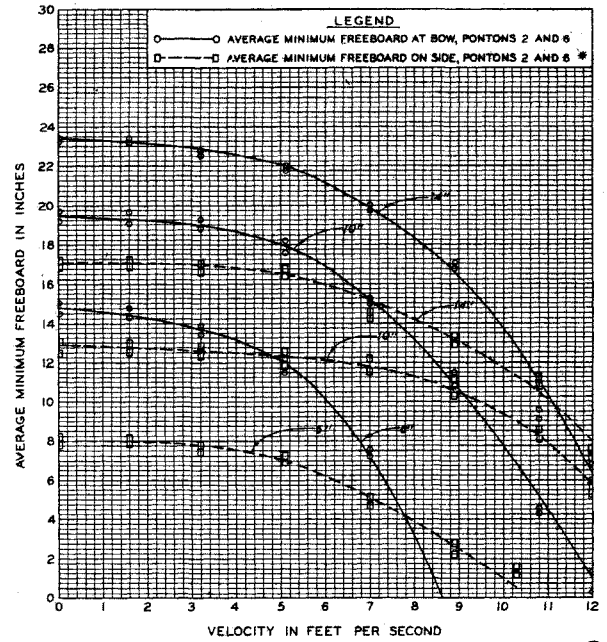
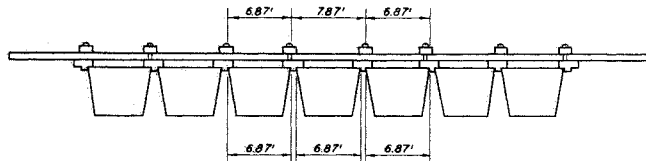
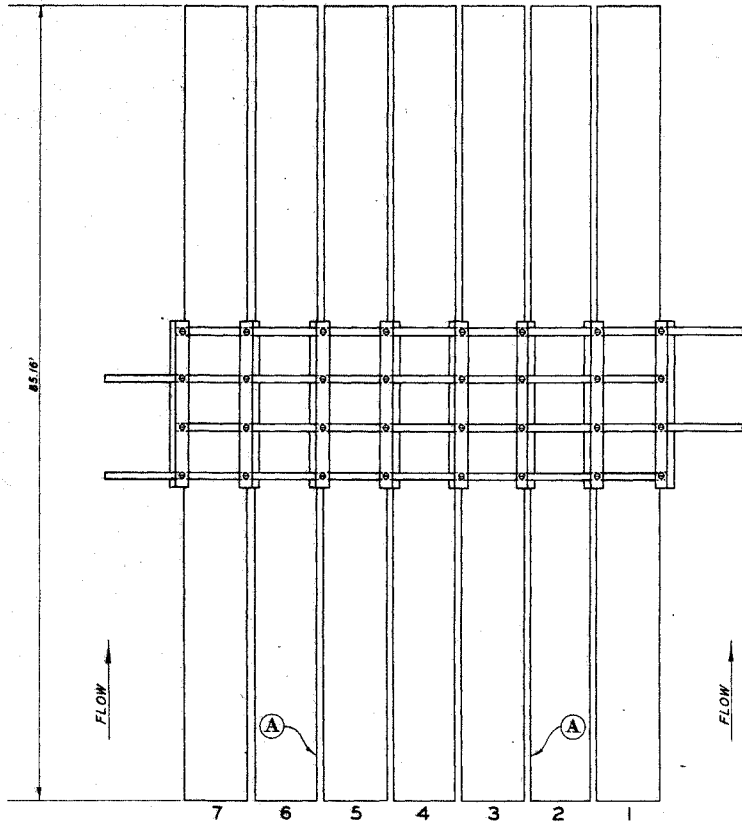

* FREEBOARD MEASUREMENTS TAKEN ALONG SIDES DENOTED BY SYMBOL (A)

TEST CONDITIONS

PONTONS ANCHORED BY LINES OVER BOW CONNECTED TO CAPSTANS. LENGTH OF ANCHOR LINE EQUALS 10 TIMES DEPTH OF FLOW. DEPTH OF FLOW EQUALS 20 FEET.

PONTON NUMBER 4 IN THE M5 RAFT WAS LOADED IN STILL WATER TO 14, 10, AND 6 INCHES FREEBOARDS ON THE STARBOARD AND PORT SIDES, RESPECTIVELY, AT START OF TEST.

**MODEL STUDY OF
PONTONS FOR M5 BRIDGE
AVERAGE MINIMUM FREEBOARD
VELOCITY CURVES**

TYPE "B" SCOW BOW PONTON-SEVEN PONTON M5 RAFT



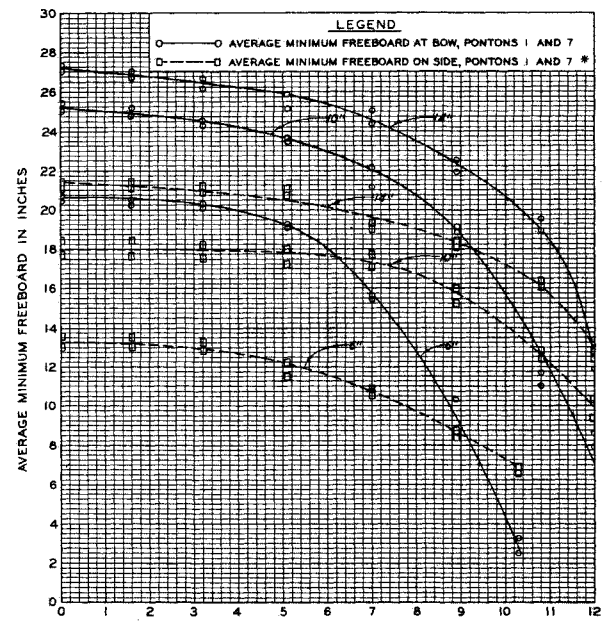
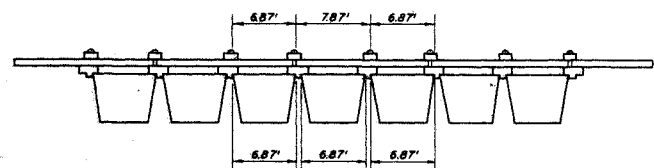
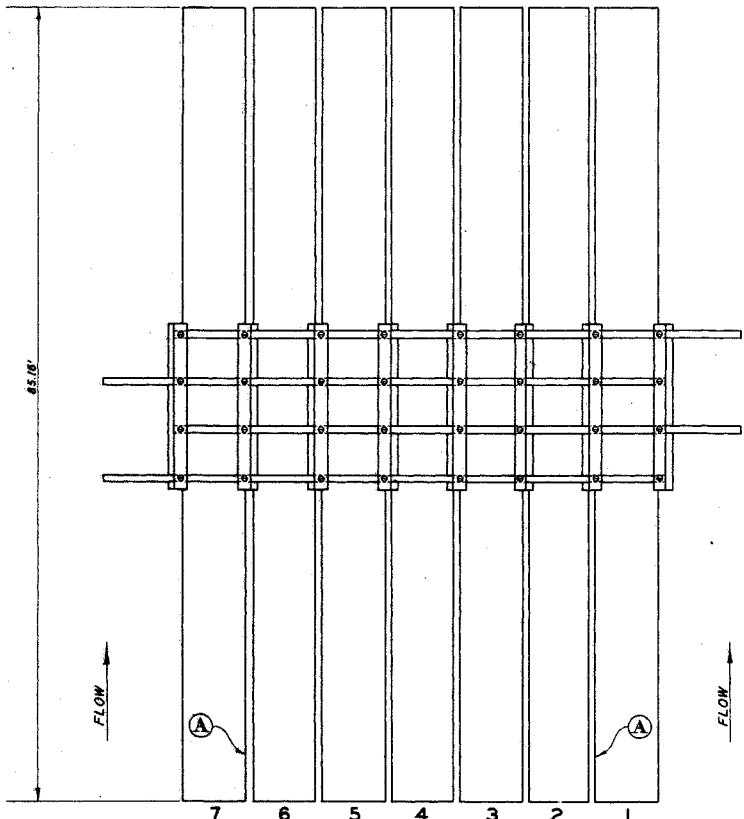

* FREEBOARD MEASUREMENTS TAKEN ALONG SIDES DENOTED BY SYMBOL (A)

TEST CONDITIONS

PONTONS ANCHORED BY LINES OVER BOW CONNECTED TO CAPSTANS.
 LENGTH OF ANCHOR LINE EQUALS 10 TIMES DEPTH OF FLOW.
 DEPTH OF FLOW EQUALS 20 FEET.
 PONTON NUMBER 4 IN THE M5 RAFT WAS LOADED IN STILL WATER
 TO 14, 10, AND 6 INCHES FREEBOARDS ON THE STARBOARD
 AND PORT SIDES, RESPECTIVELY, AT START OF TEST.

MODEL STUDY OF
 PONTONS FOR M5 BRIDGE
**AVERAGE MINIMUM FREEBOARD
 VELOCITY CURVES**
 TYPE "B" SCOW BOW PONTON-SEVEN PONTON M5 RAFT

