

TA7
.W34
no. 2-236

EQ

WAR DEPARTMENT
CORPS OF ENGINEERS
MISSISSIPPI RIVER COMMISSION

MODEL STUDY
OF
SPILLWAY AND STILLING BASIN
HARLAN COUNTY DAM, REPUBLICAN RIVER, NEBRASKA

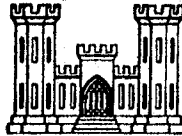

TECHNICAL MEMORANDUM NO. 2-236

WATERWAYS EXPERIMENT STATION
VICKSBURG, MISSISSIPPI

MRC-WES-150 10-47

SEPTEMBER 1947

PROPERTY OF U. S. ARMY
OFFICE CHIEF OF ENGINEERS
LIBRARY

Report Documentation Page

Form Approved
OMB No. 0704-0188

Public reporting burden for the collection of information is estimated to average 1 hour per response, including the time for reviewing instructions, searching existing data sources, gathering and maintaining the data needed, and completing and reviewing the collection of information. Send comments regarding this burden estimate or any other aspect of this collection of information, including suggestions for reducing this burden, to Washington Headquarters Services, Directorate for Information Operations and Reports, 1215 Jefferson Davis Highway, Suite 1204, Arlington VA 22202-4302. Respondents should be aware that notwithstanding any other provision of law, no person shall be subject to a penalty for failing to comply with a collection of information if it does not display a currently valid OMB control number.

1. REPORT DATE SEP 1947		2. REPORT TYPE		3. DATES COVERED 00-00-1947 to 00-00-1947	
4. TITLE AND SUBTITLE Model Study of Spillway and Stilling Basin, Harlan County Dam, Republican River, Nebraska				5a. CONTRACT NUMBER	
				5b. GRANT NUMBER	
				5c. PROGRAM ELEMENT NUMBER	
6. AUTHOR(S)				5d. PROJECT NUMBER	
				5e. TASK NUMBER	
				5f. WORK UNIT NUMBER	
7. PERFORMING ORGANIZATION NAME(S) AND ADDRESS(ES) U.S. Army Corps of Engineers, Waterway Experiment Station, 3903 Halls Ferry Road, Vicksburg, MS, 39180				8. PERFORMING ORGANIZATION REPORT NUMBER	
9. SPONSORING/MONITORING AGENCY NAME(S) AND ADDRESS(ES)				10. SPONSOR/MONITOR'S ACRONYM(S)	
				11. SPONSOR/MONITOR'S REPORT NUMBER(S)	
12. DISTRIBUTION/AVAILABILITY STATEMENT Approved for public release; distribution unlimited					
13. SUPPLEMENTARY NOTES					
14. ABSTRACT					
15. SUBJECT TERMS					
16. SECURITY CLASSIFICATION OF:			17. LIMITATION OF ABSTRACT	18. NUMBER OF PAGES	19a. NAME OF RESPONSIBLE PERSON
a REPORT unclassified	b ABSTRACT unclassified	c THIS PAGE unclassified			

CONTENTS

	<u>Page</u>
SYNOPSIS	
PART I: INTRODUCTION	
PART II: THE HARLAN COUNTY DAM PROJECT	
Design Features of Dam and Reservoir.....	5
Use of Model Analyses.....	9
PART III: THE MODEL	
Model-Prototype Scale Ratios.....	10
Interpretation of Model Results.....	10
Description of Model.....	11
PART IV: NARRATIVE OF TESTS	
Tests of Approach Area.....	14
Tests of Spillway Weir.....	14
Tests of Stilling Basin.....	16
Tests of Training Walls.....	39
PART V: DISCUSSION OF RESULTS	
PLATES 1-80	

MODEL STUDY OF SPILLWAY AND STILLING BASIN
HARLAN COUNTY DAM, REPUBLICAN RIVER, NEBRASKA

SYNOPSIS

The model study of the spillway and stilling basin for Harlan County Dam, proposed for construction on Republican River, Nebraska, was conducted primarily to ensure the adequacy of the structures as originally designed. Model tests verified the sufficiency of the initial design to pass all spillway flows; however, subsequent analysis by engineers of the Kansas City District, combined with the results of model tests and recommendations by the Office, Chief of Engineers, led to development of a revised design which performed satisfactorily and was more economical to construct.

Although the spillway crest shape as originally designed was found to be satisfactory, a reduction in gate width, necessitating an increased number of crest piers and a corresponding increase in over-all crest width, was made to provide better structural conditions. No alterations to the original spillway section were made during the course of the model study. However in several tests the discharge per foot of crest width was adjusted to simulate flow over the slightly wider crest.

The performance of the original stilling basin, incorporating a concrete apron, subdam, two rows of baffle piers, and an end sill, was very satisfactory in the dissipation of all spillway discharges. However, six alternate designs were investigated in an attempt to effect economies in construction costs. Although it was found that satisfactory stilling-basin conditions would exist with a standard hydraulic-jump type basin at

elevation 1850*, the rock excavation required was considered too costly. A basin design (type 6) was finally developed in which the exit channel downstream from the end sill was paved for a distance of about 105 ft, thus forming a control sill which artificially regulated the tailwater in the stilling basin and permitted the basin elevation to be raised. Other features of the basin were a horizontal apron 136 ft long at elevation 1862, two rows of baffle piers 8 ft high, and an end sill 15 ft in height. The model tests also indicated that a considerable reduction could be effected in the length of the training walls on either side of the stilling basin without affecting the efficiency of the basin.

* Feet above mean sea level.

PART I: INTRODUCTION

1. Authority to conduct model studies of the spillway and stilling basin of the proposed Harlan County Dam was granted by the Chief of Engineers, U. S. Army, in the second indorsement dated 7 December 1943 to a letter of the District Engineer, Kansas City District, C. E., dated 24 November 1943. The model study was conducted by the Waterways Experiment Station during the period August 1944 to July 1945.

2. The original design of the proposed Harlan County structures as tested at the Experiment Station was furnished by the Kansas City District. The model testing program also included various design modifications originating in the Office, Chief of Engineers, the Kansas City District, and the Experiment Station. During the course of the study Colonel W. E. Potter, District Engineer, Mr. L. D. MacDonald, Mr. D. H. McCoskey, and Mr. D. E. Abramowitz, Engineers of the Kansas City District, and Mr. J. P. Edstrand and Mr. F. B. Slichter, Engineers of the Missouri River Division, visited the Experiment Station at frequent intervals to discuss test results and to correlate these results with design work concurrently being carried on in the District Office. Interim reports on each phase of the test program were forwarded the District Engineer as test data became available.

3. The model study was conducted in the Hydraulics Division under the supervision of Mr. F. R. Brown, Chief of the Structures Branch. Mr. Brown was assisted by Mr. J. W. Bolin and Mr. E. S. Melsheimer, Engineers.

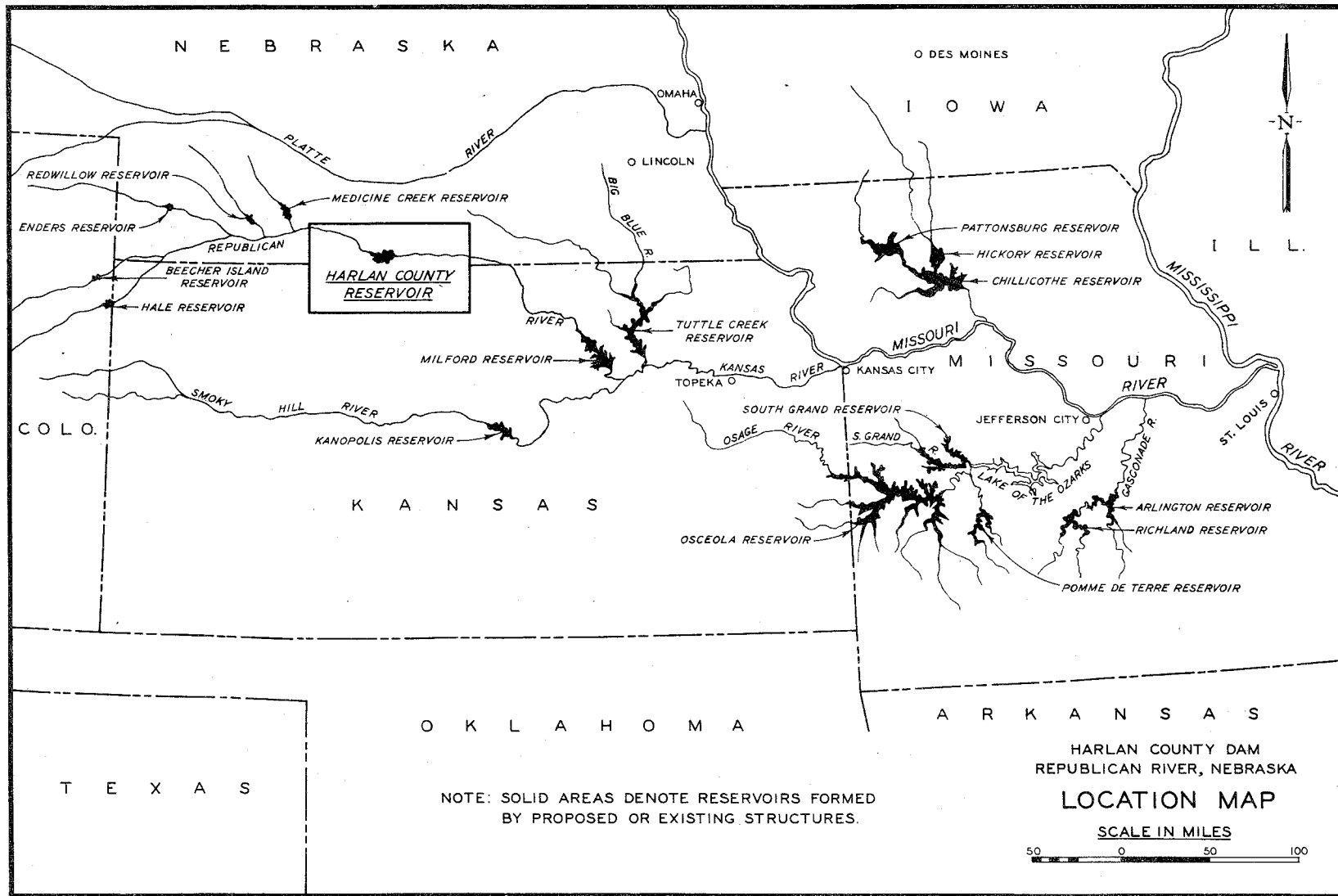

Figure 1

PART II: THE HARLAN COUNTY DAM PROJECT*

Design Features of Dam and Reservoir

4. The Harlan County Dam is proposed for construction on the Republican River, approximately three miles east of Republican City, Nebraska, and thirteen miles west of Franklin, Nebraska. Figure 1 is a location map of the area and plate 1 shows general features of the dam. The proposed dam, one of the projects in the comprehensive plan for flood control on the Missouri and Lower Mississippi Rivers, will consist of a rolled-fill earthen embankment section and a gravity-type concrete structure which will include a gate-controlled spillway, sluices, irrigation outlets, a bulkhead section to effect connection with the earth embankment, and provisions for future power installations. The main section of the dam will be about 11,150 ft long and will rise to a maximum height of 106 ft above the bed of the stream. The reservoir will provide a total storage of 850,000 acre-ft with pool at top of gates (elevation 1973.5**), of which 350,000 acre-ft is proposed for irrigation and silting allowance, and 500,000 acre-ft for flood control. The contributing drainage area for these storages is 10,043 sq mi.

Spillway

5. The original spillway design consisted of eleven crest gates, each 64 ft wide and 30 ft high, with ten 10-ft-wide piers mounted on the

* Information on prototype structures was obtained from the "Definite Project Report, Harlan County Dam, Republican River, Nebraska."

** All elevations are in ft above mean sea level.

crest, which gave gross and net spillway widths of 804 and 704 ft, respectively. Details of the original spillway and stilling basin design are presented on figure 4 and on plates 1, 2 and 8. At the request of the Office, Chief of Engineers, a buttress-type ogee spillway controlled by eighteen 40-ft-wide and 30-ft-high crest gates, with seventeen 9-ft-wide piers, also was considered. The gross and net spillway widths of this plan were 873 and 720 ft, respectively. The buttress-type spillway, however, was later supplanted by the adopted plan described below.

6. The adopted plan provides for an ogee, gravity-type spillway located in the left bank terrace. Eighteen crest gates, each 40 ft wide and 30 ft high, will control discharge over the spillway. The plan and profile of the spillway are shown on figure 2. The gross crest width is 856 ft with a net crest width of 720 ft. Seventeen 8-ft-wide piers will support the crest gates and roadway across the structure and will house the gate hoist machinery. The crest gates will be of the tainter type and will be controlled by individually-operated hoists.

7. The adopted spillway crest shape is based on the formula $Y = \frac{X^{1.85}}{39.98}$ downstream from the crest and on the formula

$$\frac{X^2}{(9.32)^2} + \frac{(5.0 - Y)^2}{(5.0)^2} = 1$$

upstream from the crest with the origin at the crest, and differs only slightly from the original design spillway crest shape on which all model tests were conducted. Coordinates for the spillway crest shape of the original design were interpolated by the Kansas City Engineer District from tables in "Davis Handbook of Applied Hydraulics" and were

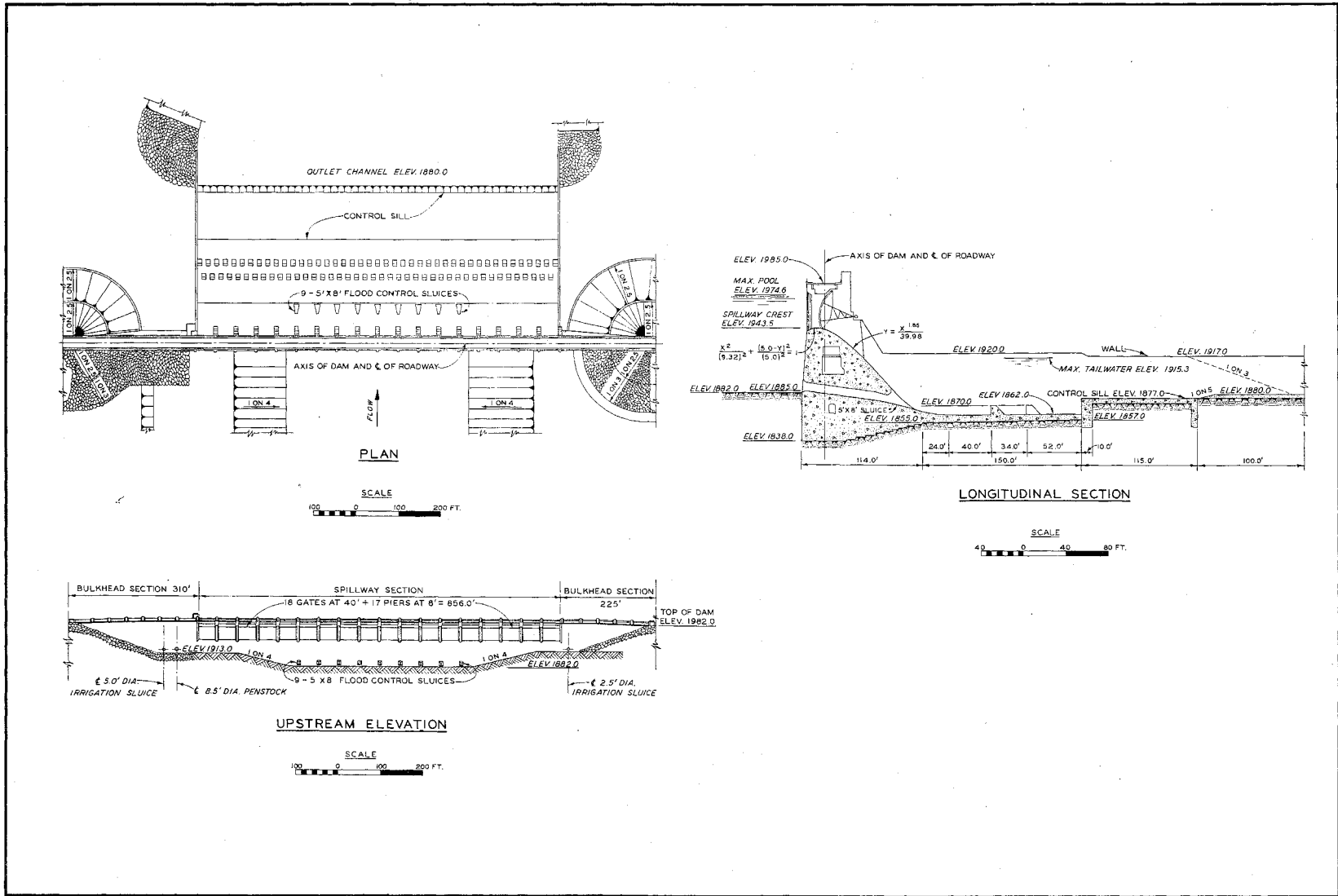

Figure 2. Details of spillway and stilling basin -- adopted design

based on a head of 30.7 ft increased by 10 per cent to 33.7 ft (plate 2) to assure positive pressure on the spillway surface.

8. The adopted stilling-basin design is designated hereafter as type 6 design and consists of a horizontal apron 136 ft long at elevation 1862, two rows of baffle piers 8 ft high, a vertical end sill 15 ft high, and a concrete control sill 105 ft long at elevation 1877 located immediately downstream from the end sill (see figure 4 for details of the design). The type 6 design is the net development of tests made on various types of stilling basins beginning with the original design (plate 8) which consisted of a concrete apron 332.69 ft long and sloping from elevation 1864.5 to elevation 1858.5, a subdam 31.1 ft high, two rows of baffle piers 10 ft high, and a stepped end sill 2 ft high.

9. Data pertaining to the adopted spillway design, and to controlling hydraulic flow conditions, are tabulated below:

a. Structural

Width of spillway crest (gross)	856 ft
Width of spillway crest (net)	720 ft
Elevation of spillway crest	1943.5 ft
Height of spillway (crest to basin)	81.5 ft
Number of crest gates (tainter)	18
Size of gates	40 ft wide by 30 ft high
Elevation of top of gates	1973.5 ft
Elevation of stilling basin	1862.0 ft

b. Hydraulic

Maximum discharge	462,000 cfs
Maximum recorded flood	260,000 cfs
Head for which crest was designed	33.7 ft
Tailwater elevation (maximum discharge)	1899.5 ft
Range in tailwater depth over control sill	22.5 ft

Regulating sluices

10. Plans for Harlan County Dam provide nine sluices through the

spillway, each 5 ft wide by 8 ft high, to regulate normal flows. The computed discharge capacity for all nine sluices with pool at top of tainter gates (elevation 1973.5 ft) is 20,000 cfs. No model tests of sluice performance were conducted.

Power structures

11. The original design for Harlan County Dam does not call for a powerhouse. However, the project plan provides a steel-lined, circular conduit 8 ft 8 in. in diameter in the event power development later becomes desirable.

Use of Model Analyses

12. Although the original design of the spillway and stilling basin for Harlan County Dam was in accord with good hydraulic design practice, and although it was not expected that model tests would indicate any appreciable changes, model analyses of the proposed structures were desired to ensure adequacy of the design. The model studies not only proved the adequacy of the original design, but were instrumental in development of an alternate, more economical stilling-basin design.

PART III: THE MODEL

Model-Prototype Scale Ratios

13. The accepted equations of hydraulic similitude, based upon the Froudian relationships, were used to express the mathematical relationships between the dimensions and hydraulic quantities of the model and the prototype. The general relationships existing for the Harlan County Dam model are presented in the following table:

<u>Dimension</u>	<u>Relationship</u>
Length	$L_r = 1:80$
Area	$A_r = L_r^2 = 1:6400$
Velocity	$V_r = L_r^{1/2} = 1:8.94$
Rate of discharge	$Q_r = L_r^{5/2} = 1:57,240$
Roughness	$n_r = L_r^{1/6} = 1:2.076$

Interpretation of Model Results

14. The lack of complete dynamic similitude, and the inability to reproduce accurately some properties of the prototype materials, impose certain limitations on model results. In general, however, the model provides data which are quantitatively applicable to the prototype. For example, measurements in the model of discharges, water-surface elevations, velocities, and pressures (all positive pressures and negative pressures corresponding to pressures above the cavitation range in the prototype) can be transferred quantitatively from model to prototype equivalents by means of the previously-mentioned scale relationships.

Evidences of scour however, are to be considered as only qualitatively reliable, since it has not been found possible to reproduce quantitatively in a model the resistance to erosion of a prototype bed material. The data on scour tendencies provide a basis for resolving the question as to the relative effectiveness of types and placement of basin elements, and indicate areas most subject to attack. Determination of the actual depth of scour to be expected in the prototype should be predicated upon the magnitude of bottom velocities and characteristics of the prototype bed material.

Description of the Model

15. The model of the spillway for Harlan County Dam, shown by figure 3, was constructed to a linear-scale ratio of 1:80. There were reproduced in the model 2000 ft of approach area, a portion of the dam,

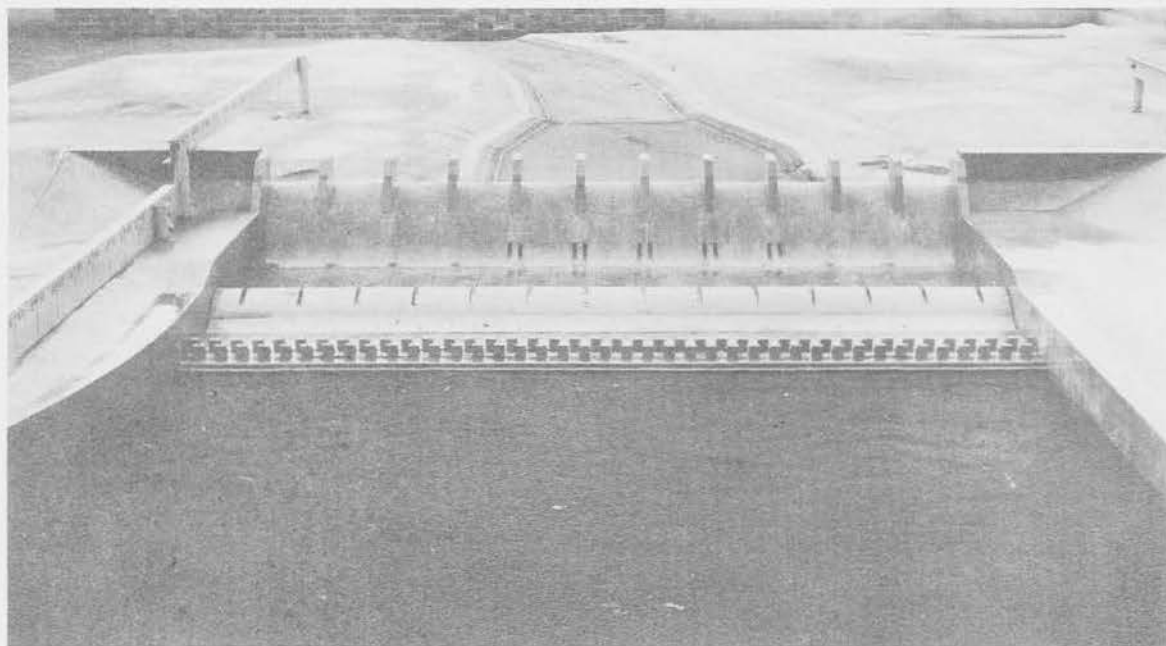

Figure 3. General view of model showing original design of structures

the spillway and sluices, the stilling basin, and 4400 ft of the exit area. The tainter gates were reproduced schematically by curved pieces of sheet metal fitted in slots in the wooden piers. The sluices were of sheet metal and were also reproduced schematically. The spillway, non-overflow sections, and the dam were molded in cement mortar to sheet-metal templates. That portion of the model downstream from the stilling basin was either fixed in cement mortar or molded in sand or coal, depending upon the type of test being conducted. Those elements representing concrete structures in the prototype were given a very smooth finish, while the remaining fixed structures or areas were given a brushed finish.

Model appurtenances and their application

16. Water used in the operation of the model was supplied by centrifugal and axial-flow pumps connected in such manner as to allow for flexibility of pump operation. The water was pumped from a large sump and measured by means of venturi meters; flow from the supply lines spilled into the model headbay where it was stilled by baffles prior to passage into the model. After passing through the model, the water returned to the sump by gravity flow through a pipeline. The tailwater in the lower end of the model was maintained at the desired depth by means of an adjustable tailgate. Steel rails set to grade in and along the sides of the model provided reference planes for measuring devices. Water-surface elevations were measured both by means of a portable point gage, mounted on an aluminum beam and supported by the above-mentioned steel rails, and by means of piezometers. Velocities were measured with

a pitot tube, the tube and its manometers also being supported by the aluminum beam. Pressures over the spillway crest and chute were measured in manometers connected by tubes to piezometer openings in the model. Soundings over the movable bed downstream from the stilling basin were taken by means of a portable sounding rod.

PART IV: NARRATIVE OF TESTS

Tests of Approach Area

17. Tests of the spillway approach area were confined to observations of flow conditions and a few velocity measurements along the upstream face of the dam. Flow conditions in the approach area were satisfactory, although there was some disturbance of flow at the two gate bays adjacent to each nonoverflow section. Velocities along the upstream face of the dam adjacent to the right spillway abutment were in the range of 4 to 9 ft per sec at the maximum discharge of 462,000 cfs.

Tests of Spillway WeirDescription

18. The original spillway design has been described in Part II of this report. Although this spillway was designed to pass a flood of 462,000 cfs under a head of 30.7 ft, actual coordinates of the weir profile as shown on plate 2 were based on a head of 33.7 ft. No alterations to the original weir section were made during the course of the model study. However, in testing the types 5 and 6 stilling-basin designs (designs recommended by the Office, Chief of Engineers), model discharges were adjusted at the request of the Kansas City District to simulate the less severe basin conditions which would exist with the buttress-type 18-gate structure under consideration at the time. This was accomplished by reducing the maximum discharge from 575 cfs per

linear ft of basin width for the 11-gate spillway to 529 cfs for the 18-gate spillway. Other discharges were reduced by corresponding amounts.

Results

19. Flow conditions. Satisfactory flow conditions obtained over the spillway weir throughout the range in discharge. It was noted that the 10-ft-wide gate piers kept overflow jets from each gate separated throughout the greater part of their descent toward the stilling basin. The drawdown created by spillway flow caused currents of considerable magnitude along the left and right spillway abutment sections, especially at high discharges. However, the safety of the dam would not be compromised by this condition, inasmuch as these nonoverflow sections would be of concrete construction.

20. Weir calibration. The rating curve as determined in the model is shown on plate 3, together with the curve computed by engineers of the Kansas City District. The relation of reservoir pool elevation to discharge was determined in increments of 50,000 cfs up to the maximum discharge of 462,000 cfs. It will be noted that the computed curve shows a slightly higher spillway efficiency than the model curve. At the maximum discharge of 462,000 cfs, the pool elevation as determined in the model was 1974.4 (30.9-ft head) as compared with the computed elevation of 1974.2 (30.7-ft head). Also shown on plate 3 is a plot of the discharge coefficients based on model data and computed from the formula

$$Q = C (L - KNH)H^{3/2}, \text{ in which}$$

Q = discharge in cfs

C = coefficient of discharge

L = net width of spillway crest (total width less pier widths)

K = a constant, the value of which depends upon the shape of the abutments and piers (assumed to be 0.015 for the Harlan County spillway)

N = the number of contractions, depending upon number and shape of the crest piers.

H = head on spillway crest

The coefficient of discharge C corresponding to the maximum discharge of 462,000 cfs was found to be 3.88. With flows adjusted to simulate the action of the buttress-type spillway as described in paragraph 18, the maximum discharge of 462,000 cfs was passed under a head of 29.3 ft. However, this is an unnatural condition in that discharge was based on flow per ft of basin width to study basin performance. For this reason and the fact that the correct number of crest piers was not reproduced for the portion of the spillway simulated, a rating curve for the buttress-type 18-gate structure was not procured. Neither was an attempt made to simulate conditions for the 18-gate structure of adopted design.

21. Water-surface and pressure profiles. Measurements of water-surface and pressure profiles along the center line of the spillway are shown on plates 4-6. The water-surface profiles permit the determination of the height of the abutment walls to contain maximum flood flows. Pressure data indicate that positive pressures would exist on the weir surface for all conditions of discharge with full-gate opening. No observations of pressure on the crest were made at partial-gate opening.

Tests of Stilling Basin

22. Figure 4 is a summary of all stilling-basin designs tested on

Design	Section Through Stilling Basin	References	Remarks
Original		<p>Figures 3, 5, 6 Plates 9-23</p>	<p>Stilling basin of original design. 332.69 ft sloping apron, 31.1 ft high subdam, 2 rows 10 ft high baffle piers and a 2 ft high end sill.</p>
Type 1		<p>Figure 7 Plates 25-31</p>	<p>122 ft apron, 2 rows 8 ft high baffle piers and a 10 ft high end sill.</p>
Type 2		<p>Figure 8 Plates 33-40</p>	<p>186 ft apron, 2 rows 11 ft high baffle piers and 3 ft high end sill.</p>
Type 3		<p>Figure 9 Plates 42-44</p>	<p>153 ft apron, 2 rows 8 ft high baffle piers and 5 ft high end sill.</p>
Type 4		<p>Figure 9 Plates 46-52</p>	<p>Same as Type 3 design, except apron elevation 5 ft lower.</p>
Type 5		<p>Figure 10 Plates 54-71</p>	<p>136 ft apron, 2 rows 8 ft high baffle piers, 10 ft high stepped end sill and a 105 ft control sill.</p>
Type 6		<p>Figures 11-12 Plates 72-75</p>	<p>Same as Type 5 design, except the 15 ft vertical end sill.</p>

Figure 4. Stilling basin designs investigated

the model, with references to figures and plates on which data pertinent to each design are presented. Tests were conducted with flows of 462,000, 300,000, 200,000 and 50,000 cfs and consisted of (a) observations of flow conditions, (b) determinations of water-surface profiles, (c) qualitative determinations of scour below the stilling basin, and (d) measurements of velocities over the apron and in the exit area. Tailwater elevations were set in accordance with the normal tailwater curve (plate 7) furnished by the Kansas City District except in certain tests in which the tailwater depth was set above and below normal depths to determine effects on basin performance.

Description -- original design

23. The stilling basin of original design, shown by figure 3 and plates 1 and 8, consisted of an apron 332.69 ft in length, sloping from elevation 1864.5 at the toe of the spillway crest section to elevation 1858.5 at the downstream extremity. Inasmuch as this apron was placed at an elevation higher than that required for formation of a hydraulic jump, a 31.1-ft-high subdam was located 157.14 ft from the toe of the spillway to provide required tailwater depths. A secondary stilling basin was provided below the subdam, containing two rows of baffle piers 10 ft high and a stepped end sill 2 ft high.

Results -- original design

24. Flow conditions. Figures 5 and 6 show flow conditions in the stilling basin of original design. Flow conditions appeared to be satisfactory throughout the range in discharge. The subdam created the necessary tailwater depths for formation of the hydraulic jump in the



Subdam elev 1890.6



Subdam elev 1885.6



Subdam elev 1880.6

Figure 5. Flow conditions in original design stilling basin showing effect of subdam elevation
Discharge 462,000 cfs; tailwater elev 1899.5



Discharge 300,000 cfs; tailwater elev 1896.5



Discharge 200,000 cfs; tailwater elev 1894.5

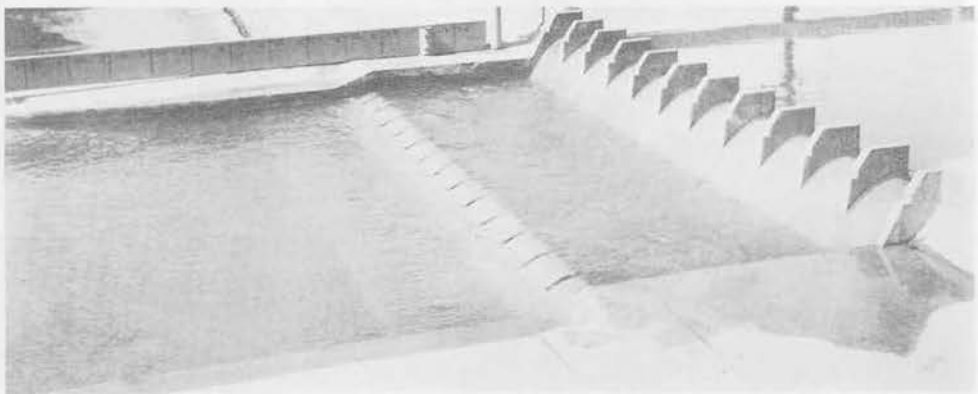

Discharge 50,000 cfs; tailwater elev 1888.5

Figure 6. Flow conditions in original design stilling basin

primary basin, and the secondary stilling basin satisfactorily dissipated all flows over the subdam. The subdam elevation was lowered 5 ft to elevation 1885.6, and later 10 ft to elevation 1880.6 to observe the effect on flow conditions. A 5-ft decrease in the height of the subdam did not change the location of the jump, although surface turbulence over the weir section was increased (figure 5). As shown in figure 5 a 10-ft reduction in the height of the subdam caused the jump to move away from the toe of the spillway at a discharge of 462,000 cfs.

25. Water-surface profiles. Average water-surface profiles measured through the stilling basin and exit channel are shown on plates 9-11. The profiles indicate that the sidewalls of the stilling basin would be sufficient to contain all flows. At the maximum discharge of 462,000 cfs, however, an occasional wave overtopped by several feet the left wall downstream from the end sill.

26. Scour. Initial tests to obtain scour patterns were conducted with the exit channel molded in sand to excavated configurations shown on plate 1. At the maximum discharge of 462,000 cfs and with the bed molded as shown on plate 1, the elevation of the exit area was such that no control could be exercised over tailwater elevations by means of the model tailgate. A tailwater elevation of 1907 was the lowest obtainable at the start of the test, whereas the computed tailwater elevation for this discharge was 1899.5. In order to obtain the computed tailwater depth, it became necessary to subject the exit channel to the erosive effect of spillway flow for some time before the estimated tailwater elevation could be attained. Plate 12 shows the scour pattern obtained during this test. In an effort to provide a more suitable

basis for comparison of test results, a test was conducted with the exit channel molded flat in sand to apron elevation of 1858.5. For the maximum discharge of 462,000 cfs the computed tailwater elevation of 1899.5 was readily attained, but the actual velocity of flow in the model was so small that movement of the sand bed was negligible (see plate 13). Accordingly, crushed coal was selected as the movable-bed material, since it is a lighter-weight material and more susceptible of movement than sand. The coal bed was molded flat to the apron elevation of 1858.5. Plates 14-16 show scour patterns obtained for discharges of 462,000, 300,000 and 200,000 cfs, respectively. The area subjected to the greatest amount of erosion was that adjacent to the left training wall. The area of deepest scour advanced downstream as the discharge increased. Additional scour tests were conducted with the subdam crest elevation lowered 5 ft and 10 ft, and despite increased turbulence in the primary basin, scour patterns (plates 17 and 18) are comparable to that observed with the original crest elevation (plate 14). It is emphasized that, as mentioned in paragraph 14, erosion tests indicate areas most subject to scouring rather than the actual depth of prototype scour to be expected.

27. Velocities. Bottom velocities over the exit channel for discharges of 462,000, 300,000 and 200,000 cfs, respectively, are shown on plates 19-21. (On all velocity plates the point of measurement is indicated by the tail of the arrow.) Bottom velocities over the exit channel varied from 1.5 to 12 ft per sec for a discharge of 462,000 cfs, from 1.5 to 9 ft per sec for a discharge of 300,000 cfs, and from 1 to 4.5 ft per sec for a discharge of 200,000 cfs. Plate 22 presents the distribution of velocities in a cross section over the end sill at

maximum discharge and indicates that a uniform distribution of flow over the end sill obtained. Supplementary tests were conducted in which the pitot tube was placed in the center of the basin immediately over the end sill to determine the effect on bottom velocities of varying the tailwater elevation. Discharges of 462,000, 300,000 and 100,000 cfs were set, the tailwater varied for each, and the resulting velocities recorded. These data are presented on plate 23. In general, the magnitude of velocities decreased as the tailwater depth was increased. However, in view of results obtained from model tests of other structures it is believed that had it been possible to increase the tailwater depths beyond those shown, the magnitude of velocities probably would have increased as a result of submergence of the hydraulic jump. For the three discharges, the velocity of flow over the end sill at normal tailwater was only 2.5 to 3 ft per sec. Bottom velocities measured in the vicinity of or over the end sill are horizontal components only of the actual velocities existing in this area.

Description -- type 1 design

28. Although the stilling basin of original design had operated satisfactorily in the dissipation of spillway flow, the Office, Chief of Engineers, requested that a standard type stilling basin be developed which would be more economical to construct. Accordingly, the type 1 stilling-basin design was tested. This design consisted of a horizontal apron 122 ft in length at elevation 1855, two rows of baffle piers 8 ft high, and a stepped end sill 10 ft high. Figures 4 and 7 and plate 24 present details of the type 1 design.

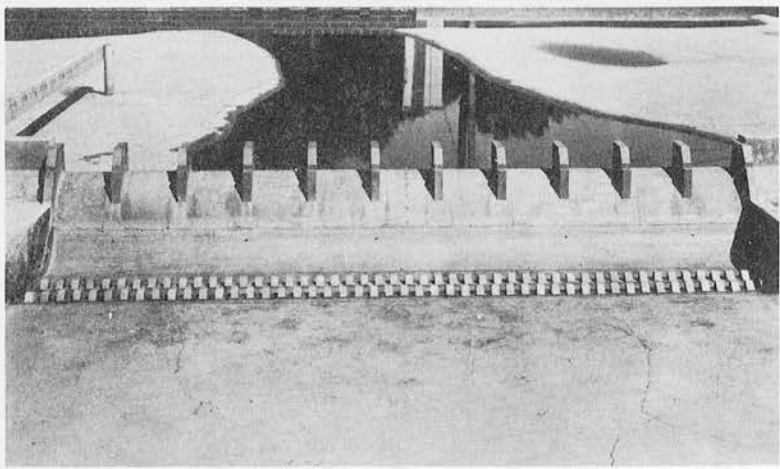

Type 1 design stilling basin

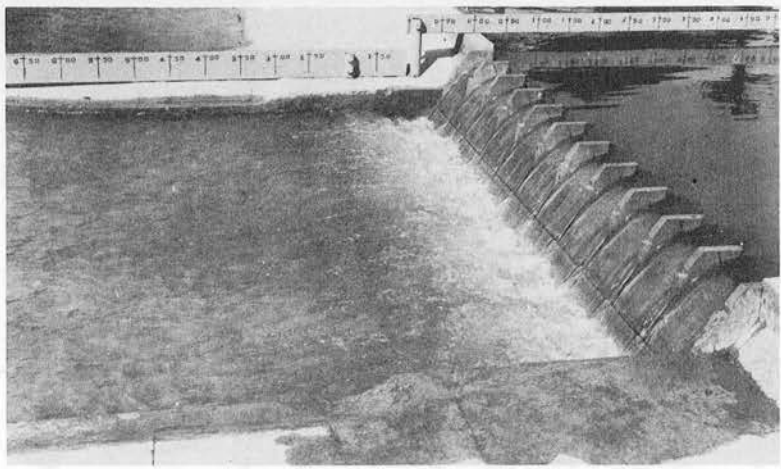

Discharge 300,000 cfs; tailwater elev 1896.5

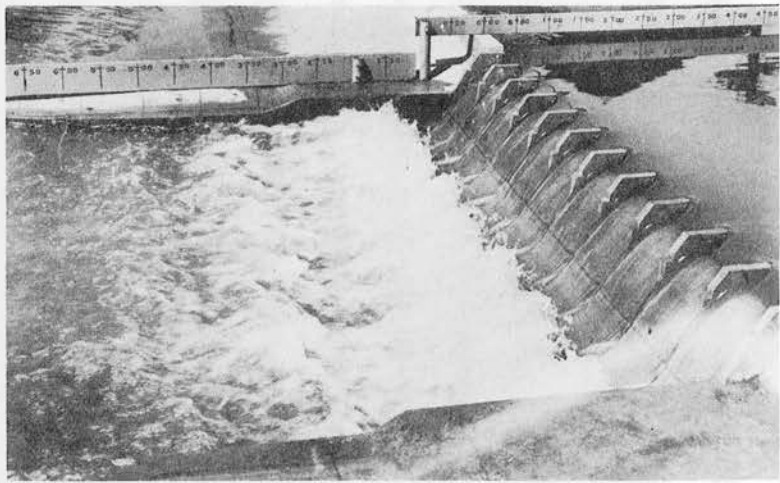

Discharge 462,000 cfs; tailwater elev 1899.5



Discharge 462,000 cfs; tailwater elev 1899.5
Baffle piers removed from apron

Figure 7. Elements and hydraulic performance of type 1 design stilling basin

Results -- type 1 design

29. Flow conditions. Flow conditions for the stilling basin of type 1 design are shown by figure 7. At the maximum discharge of 462,000 cfs, flow over the spillway impinged directly on the upstream row of baffle piers, resulting in spray action. To eliminate spray action it was necessary to increase the tailwater 3.5 ft to elevation 1903. For discharges less than the maximum, flow conditions were satisfactory, although the proximity of the baffle piers to the toe of the spillway resulted in considerable impact on the baffle piers. Several observation tests made with baffle piers removed from the apron indicated that for discharges up to 200,000 cfs, with normal tailwater elevations corresponding thereto, a good jump existed on the apron. For a discharge of 300,000 cfs the jump remained on the apron, but moved away from the toe of the spillway; while for the maximum discharge the jump, as shown in figure 7, was swept out of the apron, and flow impinged directly on the end sill. An increase of 7.5 ft and 8.5 ft in tailwater depth above normal for discharges of 300,000 and 462,000 cfs, respectively, permitted the formation of a good hydraulic jump.

30. Water-surface profiles. An average water-surface profile through the stilling basin and exit channel for a discharge of 300,000 cfs is shown on plate 25. This profile defines the position of the hydraulic jump with respect to the toe of the spillway and stilling-basin elements. The sudden change from subcritical to supercritical depth indicates that the baffle piers were subjected to considerable impact. No profile is presented for conditions of the maximum discharge since spray action existed at normal tailwater elevation.

31. Scour. Plates 26-28 show the results of scour tests conducted on the stilling basin of type 1 design at discharges of 300,000 and 200,000 cfs. Comparison of these scour results with those for the original design (plates 15 and 16) reveals that the tendency to scour was more severe with the stilling basin of type 1 design installed. In the comparison of scour patterns, it should be noted that, for the most part, the bed of the exit area is molded at different elevations at the start of each series of tests, depending on the type basin being investigated. In order to note the effect of the baffle piers on erosion tendencies, the baffle piers were removed from the apron and a scour pattern was obtained for a discharge of 200,000 cfs. As shown on plate 28, the magnitude of scour was almost double that obtained for the same discharge with baffle piers in place.

32. Velocities. Bottom velocities over the exit channel, recorded for discharges of 300,000 and 200,000 cfs, are presented on plates 29 and 30. Bottom velocities in the exit channel varied from 8 to 20 ft per sec for a discharge of 300,000 cfs, and at a discharge of 200,000 cfs they were in the range from 7.5 to 16 ft per sec. These velocities were much higher than the velocities obtained for similar discharges on the original design stilling basin (plates 20 and 21). The reduction in cross-sectional area of the exit channel probably was responsible in part for the higher velocities. For discharges of 462,000, 300,000 and 200,000 cfs, the tailwater elevation was varied and the velocity over the end sill was measured. These data, presented on plate 31, indicate that velocities over the sill at normal tailwater elevation for the above discharges varied from about 6 to 18 ft per sec, whereas similar tests

conducted with the original design (plate 23) produced velocities of from 2.5 to 3 ft per sec.

Description -- type 2 design

33. The type 2 design stilling basin was developed by the Kansas City District after the Office, Chief of Engineers, had requested revision of the original design. In this design, details of which are shown by figure 4 and on plate 32, the basin consisted of an apron 186 ft in length, sloping from elevation 1847 at the toe of the spillway to elevation 1842 at the downstream end, two rows of 11-ft baffle piers, and a 3-ft stepped end sill.

Results -- type 2 design

34. Flow conditions. Flow conditions in the type 2 design stilling basin appeared to be satisfactory for all conditions of discharge. At discharges of 462,000 and 300,000 cfs, shown by figure 8, a good hydraulic jump occurred. At lower flows the jump tended to submerge; however, the baffle piers and end sill deflected all high velocity currents away from the bed of the exit channel. At the maximum discharge of 462,000 cfs, the tailwater was lowered 4 ft without appreciable effect on stilling-basin action and was lowered 12 ft before spray action occurred.

35. Water-surface profiles. Reference is made to plate 33, which shows the water-surface profile through the stilling basin and exit channel for a flow of 462,000 cfs. This profile indicates the position of the hydraulic jump with respect to the toe of the spillway, baffle piers and end sill. As in the case of the original basin design, the

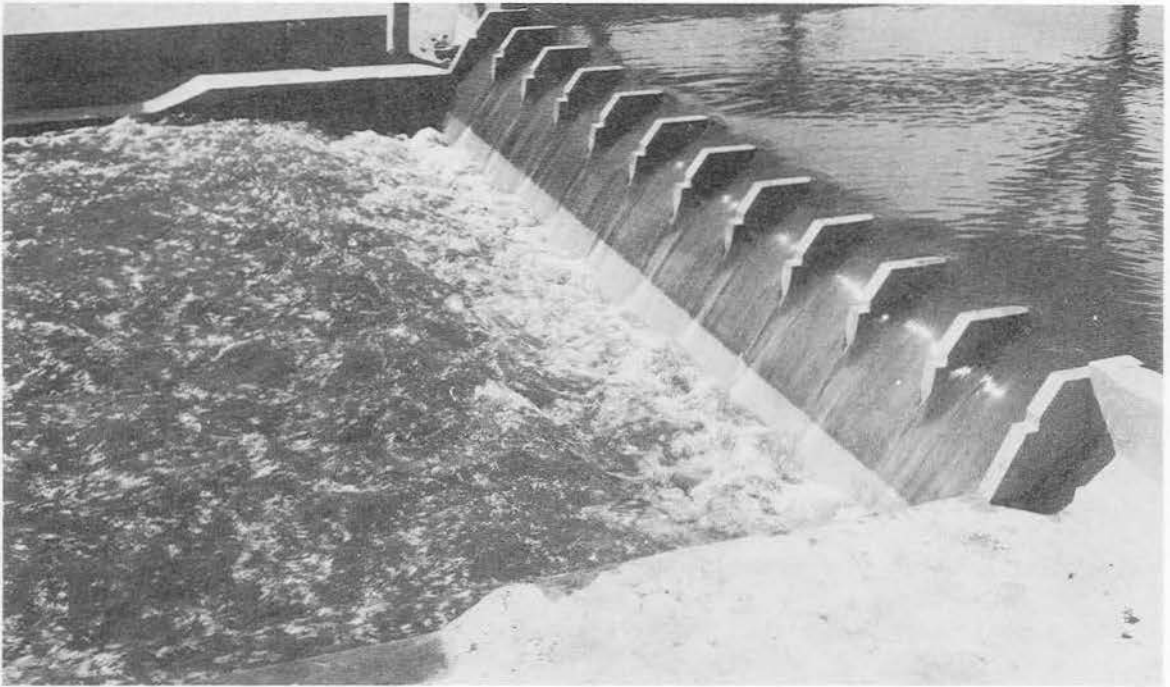

Discharge 462,000 cfs; tailwater elev 1899.5

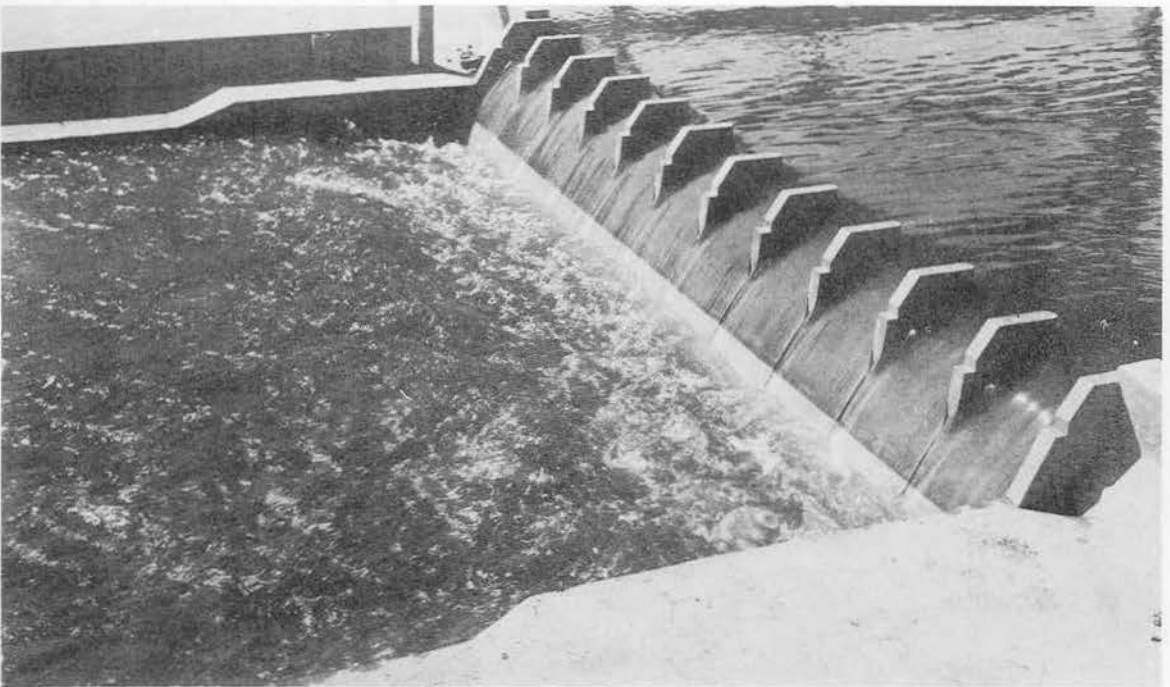

Discharge 300,000 cfs; tailwater elev 1896.5

Figure 8. Flow conditions in type 2 design stilling basin

left training wall was overtopped by occasional waves at the maximum discharge of 462,000 cfs.

36. Scour. Plates 34-36 present the results of scour tests conducted at discharges of 462,000, 300,000 and 200,000 cfs. Comparison of scour tests on the type 2 design stilling basin with those obtained on the previously-described stilling-basin designs (plates 14-16 and 26-27) indicates that the type 2 design is the most satisfactory of the three designs.

37. Velocities. Bottom velocities over the exit channel recorded for discharges of 462,000, 300,000 and 200,000 cfs are presented on plates 37-39. Bottom velocities in the exit channel varied from 5 to 10 ft per sec for a discharge of 462,000 cfs. For a discharge of 300,000 cfs bottom velocities varied from 3 to 8 ft per sec, and at a discharge of 200,000 cfs, from 2 to 5.5 ft per sec. Bottom velocities for this design were comparable to those of the original design (plates 19-21) and were much lower than those of the type 1 design (plates 29-30). For discharges of 462,000, 300,000 and 200,000 cfs the tailwater elevation was varied and the corresponding velocity over the end sill was measured. These data are shown on plate 40. Velocities over the end sill at normal tailwater elevation varied from 2 ft per sec for a discharge of 100,000 cfs to 6 ft per sec for a discharge of 462,000 cfs.

Description -- types 3 and 4 designs

38. The types 3 and 4 designs were developed in an attempt to raise the elevation of the stilling basin of type 2 design and thereby reduce the amount of excavation required. The stilling basins of types

3 and 4 designs were similar, except that the type 3 design basin was located at elevation 1855 and the type 4 design basin at elevation 1850. As shown on plates 41 and 45, each of these basins consisted of a horizontal apron 153 ft long with two rows of baffle piers 8 ft high and a stepped end sill 5 ft high.

Results -- types 3 and 4 designs

39. Flow conditions. Figure 9 shows flow conditions in the types 3 and 4 stilling basins for discharges of 462,000 and 300,000 cfs. Flow conditions with the type 3 stilling basin and the maximum discharge were unsatisfactory in that flow from the spillway impinged directly on the baffle piers. For a discharge of 300,000 cfs and lower, good stilling-basin performance resulted. The 5-ft reduction in basin elevation of the type 4 design was successful in providing good flow conditions at all discharges. The additional 5 ft of tailwater over the basin caused the jump to form at the toe of the spillway, thus providing some tailwater cushion over the baffle piers.

40. Water-surface profiles. Shown on plates 42 and 46 are water-surface profiles through the types 3 and 4 stilling basins for discharges of 300,000 and 462,000 cfs, respectively. These data supplement figure 9 in demonstrating that good jump action obtained in the type 3 basin with a discharge of 300,000 cfs and in the type 4 basin at all flows, including the maximum.

41. Scour. Plates 43 and 47-49 show the results of scour tests conducted with the types 3 and 4 basins. Only the scour results at a discharge of 300,000 cfs are presented with the type 3 basin for

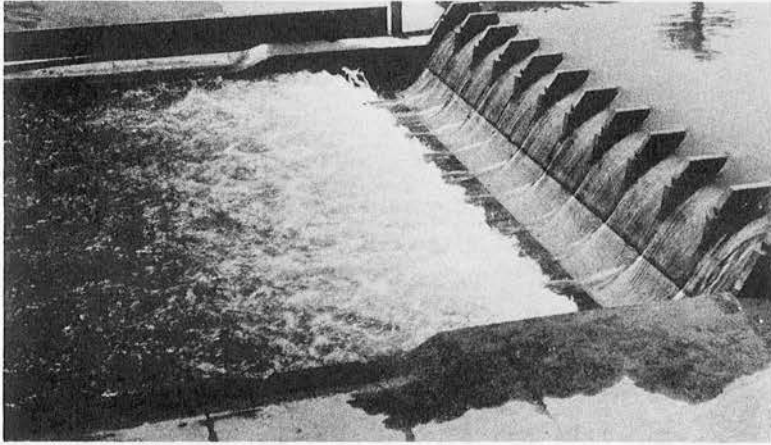

Type 3 design
Discharge 462,000 cfs; tailwater elev 1899.5

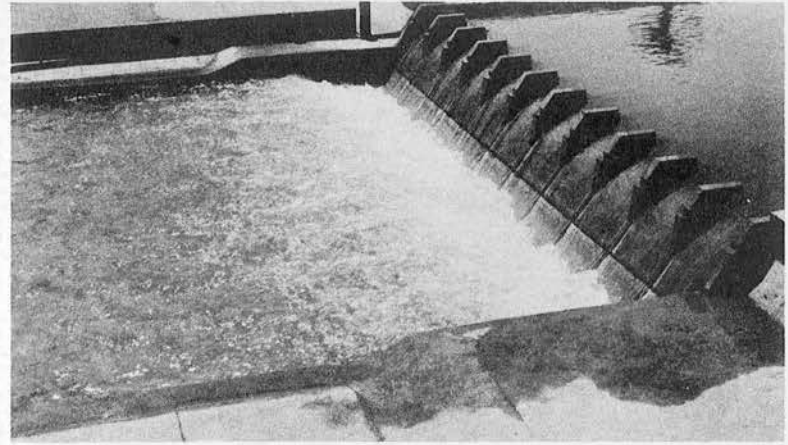

Discharge 300,000 cfs; tailwater elev 1896.5

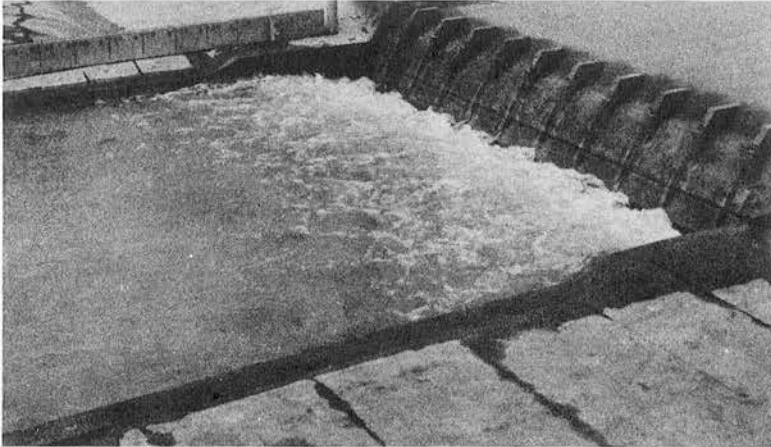

Type 4 design
Discharge 462,000 cfs; tailwater elev 1899.5

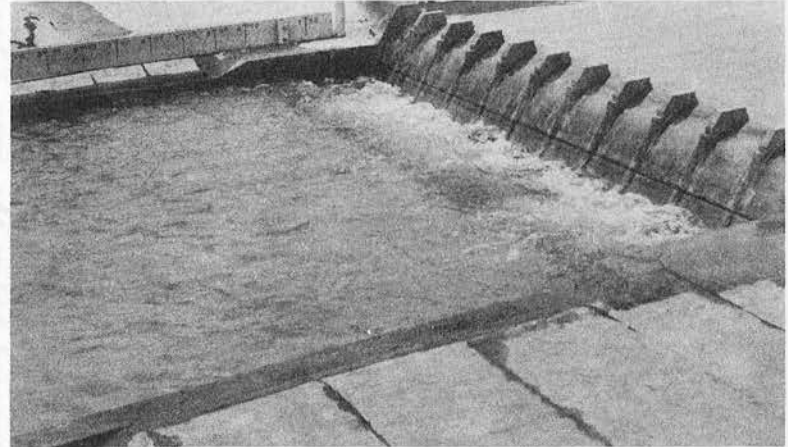

Discharge 300,000 cfs; tailwater elev 1896.5

Figure 9. Flow conditions in types 3 and 4 design stilling basins

comparison with the results of the type 4 basin. Inasmuch as flow conditions were unsatisfactory at the maximum discharge with the type 3 basin, this design was not considered worthy of extensive investigation. Scour results secured with the type 4 basin indicate that this design is comparable to the original and type 2 designs but more efficient than the basin of type 1 design.

42. Velocities. Bottom velocities recorded for a discharge of 300,000 cfs with the type 3 basin and at all flows with the type 4 basin are presented on plates 44 and 50-52. These data reveal that bottom velocities in the exit area immediately below the type 4 design basin were about 8 ft per sec at the maximum discharge and decreased in magnitude as the discharge was reduced. Comparison of these results with the data secured below the type 3 basin indicates that velocities below the type 4 basin were slightly lower. No velocities were recorded with the type 3 basin and the maximum discharge because of the undesirable flow conditions described previously. As demonstrated by the erosion tests, velocities below the type 4 basin were comparable to those recorded below the original and type 2 basins and somewhat less than those recorded below the type 1 basin.

Description -- types 5 and 6 designs

43. Although previous model tests had indicated superiority of the type 4 stilling-basin design from the standpoint of hydraulic performance, the types 5 and 6 stilling-basin designs were investigated on instructions from the Office, Chief of Engineers, in an effort to effect still further economies in construction. These designs were unlike the

type 4 design in principle, in that the elevation of the type 4 basin was such as to cause a hydraulic jump to form with existing tailwater, whereas in the types 5 and 6 designs the basin was raised 12 ft and the formation of a jump in the stilling basin was dependent upon the prevention of scour in the exit channel. To maintain the elevation of the exit channel at 1877, it was planned to pave about 100 ft of the area below the end sill. It was believed that downstream from the paved area, or control sill, the quality of the prototype bed rock is such that the maximum amount of erosion would not be below elevation 1865. The types 5 and 6 designs were similar except that the type 5 design had a 10-ft stepped end sill whereas the type 6 design had a 15-ft vertical end sill. Each design incorporated a horizontal apron 136 ft long at elevation 1862, with two rows of 8-ft baffle piers. Details of the types 5 and 6 designs are shown by figure 4 and on plate 53.

Results -- types 5 and 6 designs

44. Flow conditions. Figure 10 shows flow conditions in the type 5 stilling basin. For normal tailwater conditions, with the bed of the exit channel fixed at elevation 1877, the control sill provided sufficient tailwater over the basin area for the formation of a hydraulic jump in the basin. It was observed, however, that the baffle piers were subjected to considerable impact. A second series of tests, conducted to study the effect of lowering the elevation of the exit channel below the control sill to elevation 1865, indicated that a secondary jump formed immediately downstream from the control sill for the condition of maximum discharge. A partial jump occurred in this area for discharges

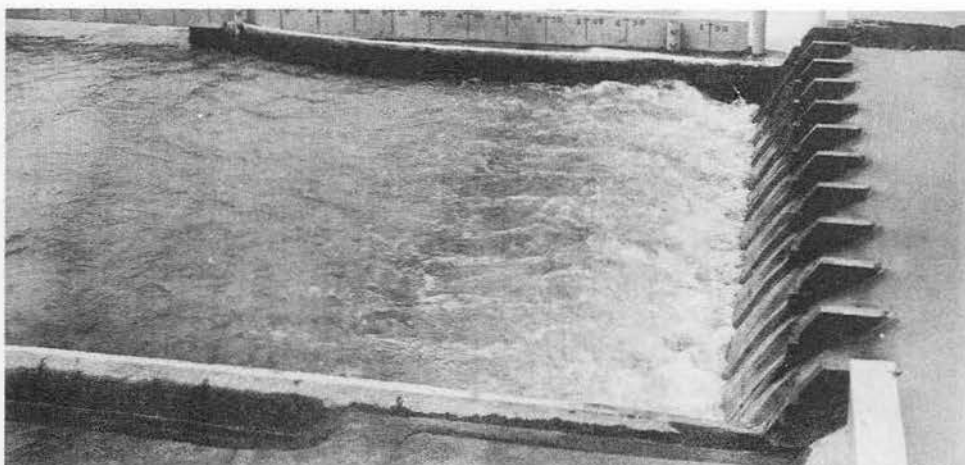

Exit channel elev 1877; discharge 462,000 cfs; tailwater elev 1899.5

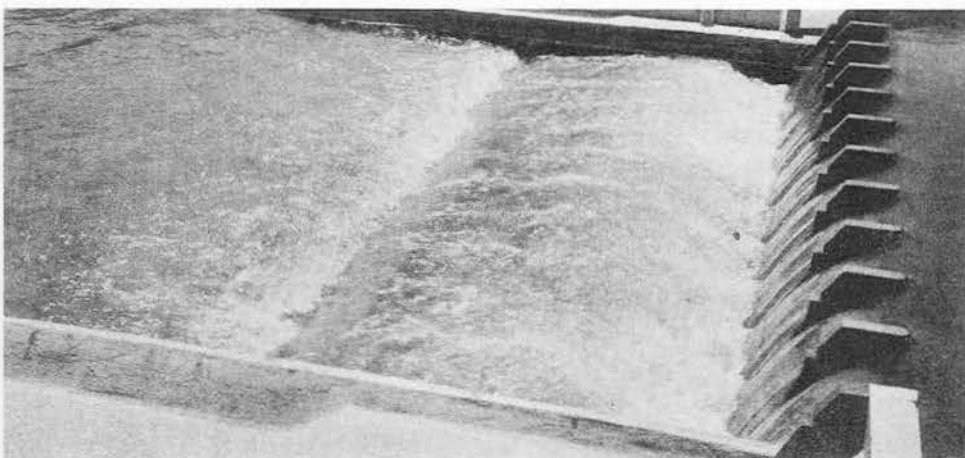

Exit channel elev 1865; discharge 462,000 cfs; tailwater elev 1899.5

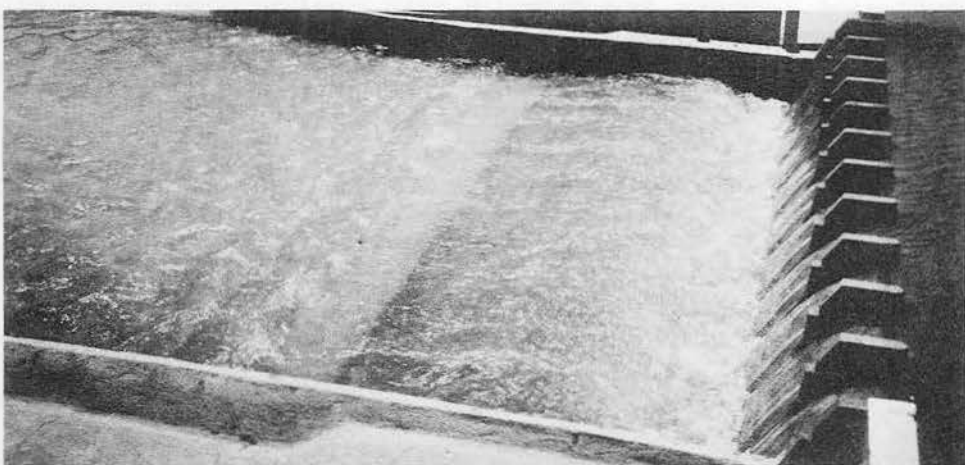

Exit channel elev 1865; discharge 300,000 cfs; tailwater elev 1896.5

Figure 10. Flow conditions in type 5 design stilling basin

of 300,000 and 200,000 cfs. An increase in tailwater depth to about 2 to 6 ft above normal elevation eliminated the secondary jump and standing waves. In tests conducted with the baffle piers removed, the jump was swept from the apron. However, the model indicated that if the paved control sill should fail and erosion of the area occur, the backwater effect gained through roller action was sufficient to maintain a jump in the basin. Figure 11 shows flow conditions in the type 6 stilling basin which were similar to those obtained with the type 5 design basin. It is to be noted that shorter training walls developed during the investigation of the type 5 design basin were used. Tests concerning training wall lengths are discussed later in paragraph 48. For maximum discharge conditions and with the exit channel below the control sill at elevation 1865, a secondary jump occurred downstream from the control sill; for discharges of 300,000 and 200,000 cfs standing waves were formed in this area. With the baffle piers removed from the apron and maximum discharge conditions, the 15-ft vertical end sill was sufficient to prevent the loss of the jump, although it did move away from the toe of the spillway. With baffle piers installed, however, failure of the control sill would result in spray action at maximum discharge. To ensure satisfactory performance of the stilling basin with baffle piers installed, it would appear to be desirable to pave the control sill during initial construction.

45. Water-surface profiles. Average water-surface profiles obtained during tests of the type 5 stilling basin are presented on plates 54-60. No profiles were measured with the type 6 stilling basin installed, as observations showed that the two designs produced similar

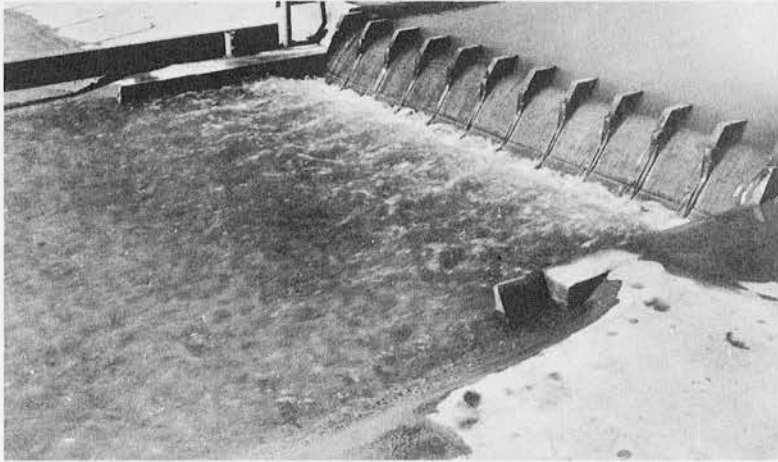

Exit channel elev 1877 (top of control sill)
Discharge 462,000 cfs; tailwater elev 1899.5

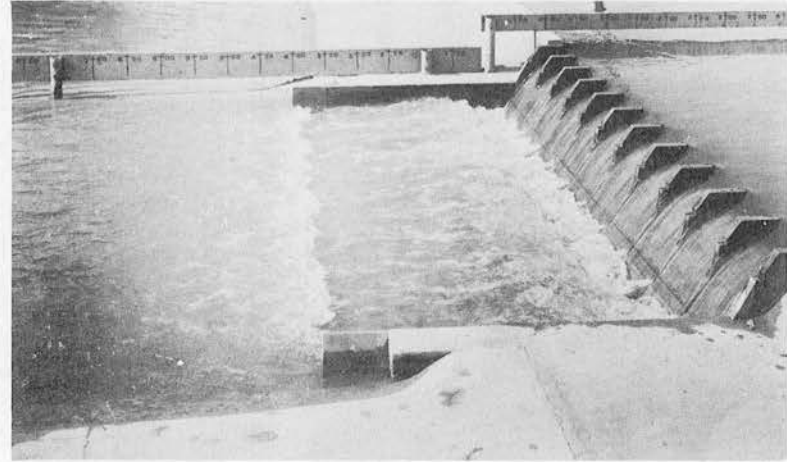

Exit channel downstream from control sill elev 1865
Discharge 462,000 cfs; tailwater elev 1899.5

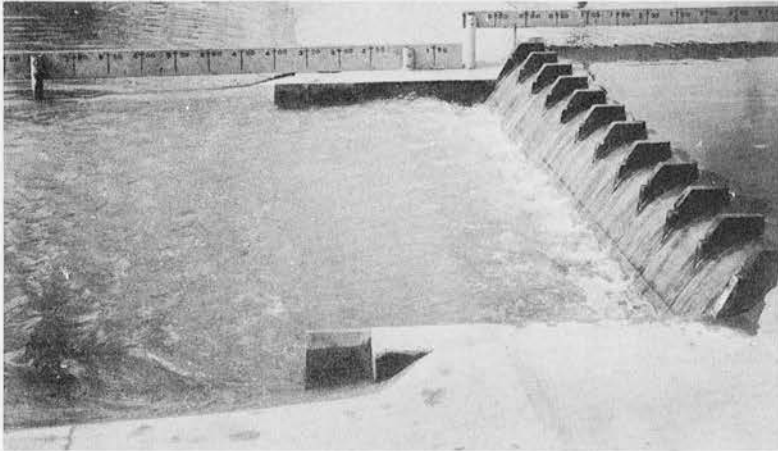

Exit channel downstream from control sill elev 1865
Discharge 300,000 cfs; tailwater elev 1896.5

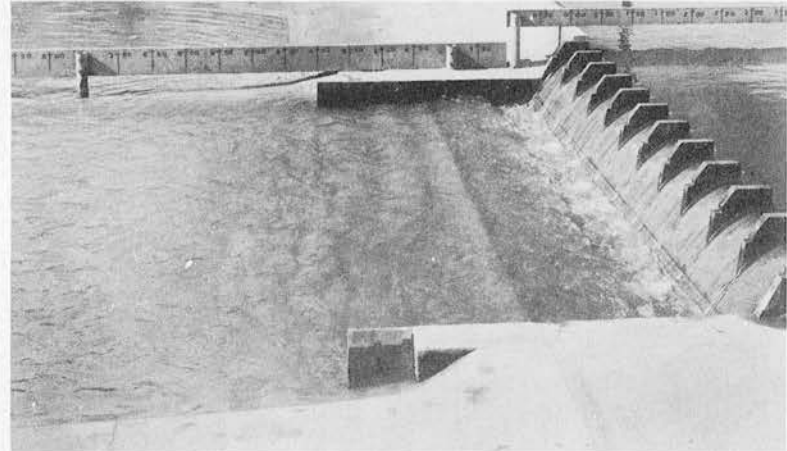

Exit channel downstream from control sill elev 1865
Discharge 200,000 cfs; tailwater elev 1864.5

Figure 11. Flow conditions in type 6 design stilling basin

profiles. Profiles taken for the type 5 basin demonstrate the effectiveness of stilling-basin elements and the sufficiency of the sidewalls to contain all flows. The sudden change from subcritical to supercritical depth, as shown on plates 54-56, indicates that the baffle piers may be subjected to heavy impact. Plate 57 shows the effect on water-surface profiles of increasing the tailwater elevation. Should the exit area below the control sill erode to elevation 1865, a secondary jump would occur (plates 58-60).

46. Scour. During all scour tests with the types 5 and 6 designs, the exit channel immediately downstream from the control sill was molded flat in sand to elevation 1877. For these tests sand replaced the crushed coal, which had been used as movable-bed material in the other basin designs tested. The use of sand as a movable-bed material was made necessary by the fact that crushed coal moved too readily under velocities existing in the exit channel with the types 5 and 6 design basins in place. Plates 61-63 show the results of scour tests with the type 5 design basin and discharges of 462,000, 300,000 and 200,000 cfs. Plates 72 and 73 show the results of scour tests for discharges of 462,000 and 200,000 cfs with the type 6 design basin. Comparison of scour results for the types 5 and 6 designs indicates that for the maximum discharge conditions slightly less erosion was recorded with the type 6 design than with the type 5 design, while at a discharge of 200,000 cfs about the same degree of protection was afforded the exit channel. Although erosion tendencies below the control sill were greater with the types 5 and 6 designs than with the other basin designs investigated, paving the control sill should prevent any damage to the stilling

basin proper by erosion.

47. Velocities. Bottom velocities over the exit channel (bed elevation 1877) for the type 5 stilling basin were recorded at discharges of 462,000 and 200,000 cfs for normal tailwater elevation, and at a discharge of 462,000 cfs with raised tailwater elevation. These data are presented on plates 64-66. With the exit channel molded to elevation 1877 and normal tailwater elevations, bottom velocities were in the range of 18 to 24 ft per sec for a discharge of 462,000 cfs, and 14 to 18.5 ft per sec for a discharge of 200,000 cfs. An increase in tailwater elevation to 17.5 ft above normal at the 462,000 cfs discharge reduced bottom velocities by approximately 50 per cent. Additional tests were conducted in which the exit channel was molded to elevation 1865. Plates 67-69 show results of these tests for discharges of 462,000, 300,000 and 200,000 cfs. Bottom velocities for a discharge of 462,000 cfs varied from 12 to 31.5 ft per sec. For a discharge of 300,000 cfs bottom velocities varied from 7.5 to 24.5 ft per sec, and at a discharge of 200,000 cfs they were in the range of 5 to 19 ft per sec. Examination of plates 67-69 reveals that the drop from the top of the control sill (elevation 1877) to the bed of the exit channel (elevation 1865) increased velocities over the end of the control sill; however, the additional depth of water downstream from the control sill reduced velocities in this area. Immediately downstream from the control sill velocities were upstream in direction. In order to determine the effect of baffle piers on velocities, tests were conducted in which bottom velocities were measured in the stilling basin, with and without baffle piers, for discharges of 462,000, 300,000 and 200,000 cfs. These data are presented on plate 70. With baffle

piers installed, bottom velocities in the stilling basin were lower than with baffle piers removed. For maximum discharge conditions, with both normal and raised tailwater elevations, the distribution of velocities over the channel cross section at the top of the upstream end of the control sill is presented on plate 71. The few observations with raised tailwater elevations were made to investigate the effect of greater depth on bottom velocities. Bottom velocities for the type 6 stilling basin were measured for discharges of 462,000 and 200,000 cfs with the exit channel molded to elevation 1877. These data are presented on plates 74 and 75. Further investigation of velocities with the type 6 design were discontinued because of the similarity to the type 5 design.

Tests of Training Walls

48. During the course of the model study the feasibility of reducing the lengths of the training walls was considered, and while testing the type 5 design basin this phase of the design was studied in detail. In all previous designs the training walls extended approximately 872 ft downstream from the axis of the dam. As the end sill of the type 5 basin was located at sta 2+52.95, the length of the training walls beyond the end sill was about 620 ft. Visual observations and scour patterns (figure 12 and plates 76-80) indicated that shortening the training walls by about 415 ft had no appreciable effect on erosion below the stilling basin. Although the walls were reduced in length, they still extended 205 ft downstream from the end sill or 100 ft downstream from the control sill. Extension of the training walls beyond the control sill was considered necessary to ensure

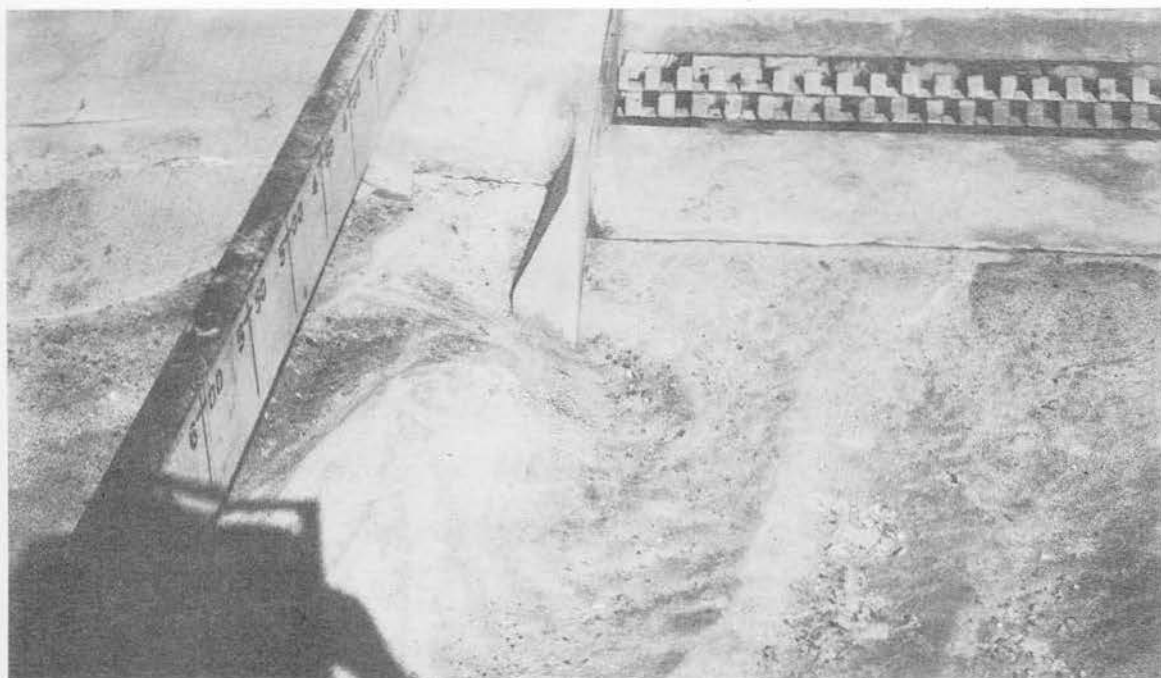

Upstream view showing scour below the right training wall
after 1 hr of operation



Upstream view showing scour below the left training wall
after 1 hr of operation

Figure 12. Scour results -- type 6 design basin, length of training wall reduced 415 ft; discharge 462,000 cfs; tailwater elev 1899.5

protection to the sill in the event that the tailwater dropped below the computed depth. It was noted during tests of the training walls that eddy action in the vicinity of the ends of the walls was intensified as the length was reduced. However, indications are that eddy action would not be troublesome so long as the walls extended as much as 100 ft downstream from the control sill.

PART V: DISCUSSION OF RESULTS

49. The model study of Harlan County Dam served its purpose by verifying the adequacy of the structures as originally designed and providing the answers to questions arising in connection with the design of various elements of the spillway and stilling basin. The model tests also demonstrated the performance of alternate basin designs, which, when reviewed in the light of hydraulic performance and economic considerations, provide the basis for establishment of the revised design of the Harlan County Dam structures.

50. The spillway crest shape as originally designed was found to be satisfactory; however, a reduction in gate width was made to improve structural conditions. This decrease in the width of the gates from 64 to 40 ft necessitated an increase in the number of crest piers and a correspondingly greater over-all crest width. Pressures over the spillway crest were positive for all conditions of free overflow. The drawdown effect of the spillway resulted in some high-velocity currents over the earth embankment at the right abutment of the spillway, but heavy riprap placed in this area should provide adequate protection.

51. The performance of the stilling basin as originally designed was satisfactory at all discharges. Good hydraulic-jump action obtained and bottom velocities over the exit area were negligible even at the maximum discharge of 462,000 cfs. However, in comparing the performance of the stilling basin as originally designed with that of other basins tested, the extreme length of the original design basin should be considered.

52. At the request of the Office, Chief of Engineers, attempts to design a standard hydraulic-jump type basin were undertaken to effect economies in construction. Tests conducted with the basin at elevation 1844 (type 2 design) -- the elevation providing the necessary tailwater depth for the natural formation of a hydraulic jump at maximum discharge -- indicated satisfactory flow conditions at all discharges. However, because of the additional rock excavation required, attempts were made to raise the elevation of the basin as much as possible without endangering the safety of the structure. Tests of the types 3 and 4 basins, with elevations of 1855 and 1850, respectively, indicated the maximum elevation of basin was 1850. At higher elevations, baffle piers or an end sill were necessary to maintain a hydraulic jump on the apron at the maximum discharge. Therefore, of the basins tested, the type 4 design is believed to be the most satisfactory of the standard jump-type basins. With this design, bottom velocities in the exit channel did not exceed 12 ft per sec at the maximum discharge.

53. Although model tests revealed the type 4 design to be satisfactory, the desire for further reduction in construction costs resulted in the development of the types 5 and 6 designs. In these designs, the control sill formed by paving the exit channel downstream from the end sill, regulated tailwater in the stilling basin and permitted use of a basin elevation of 1862. Actually the types 5 and 6 design basins were similar in action to the original basin design, inasmuch as the control sill served the same purpose as the subdam. However, either the type 5 or type 6 design would be more economical to construct than the original design or any of the jump-type basins investigated. The paved area

immediately downstream from the end sill provided sufficient tailwater depths to form a hydraulic jump in the stilling basin, but velocities over the paved area were high and were in the range of 18 to 24 ft per sec in the exit area for conditions of maximum discharge. The vertical sill of the type 6 design provided more satisfactory conditions in the stilling basin than the stepped sill of the type 5 design, since with the former design the baffle piers could be removed and the hydraulic jump would remain within the basin area. It is recommended, however, that baffle piers be used to provide additional protection to the stilling basin and the exit area immediately downstream.

54. The length of the training walls extending downstream from the stilling basin had little or no effect on basin performance. The long walls of the original design appear unnecessary, and it is recommended that the walls be shortened 415 ft to a point 100 ft downstream from the control sill. The shortened walls were tested in conjunction with the types 5 and 6 basin designs, and should provide the necessary protection to the control sill. They also would confine the secondary wave or jump which existed in the area downstream from the control sill under certain test conditions.

PLATES

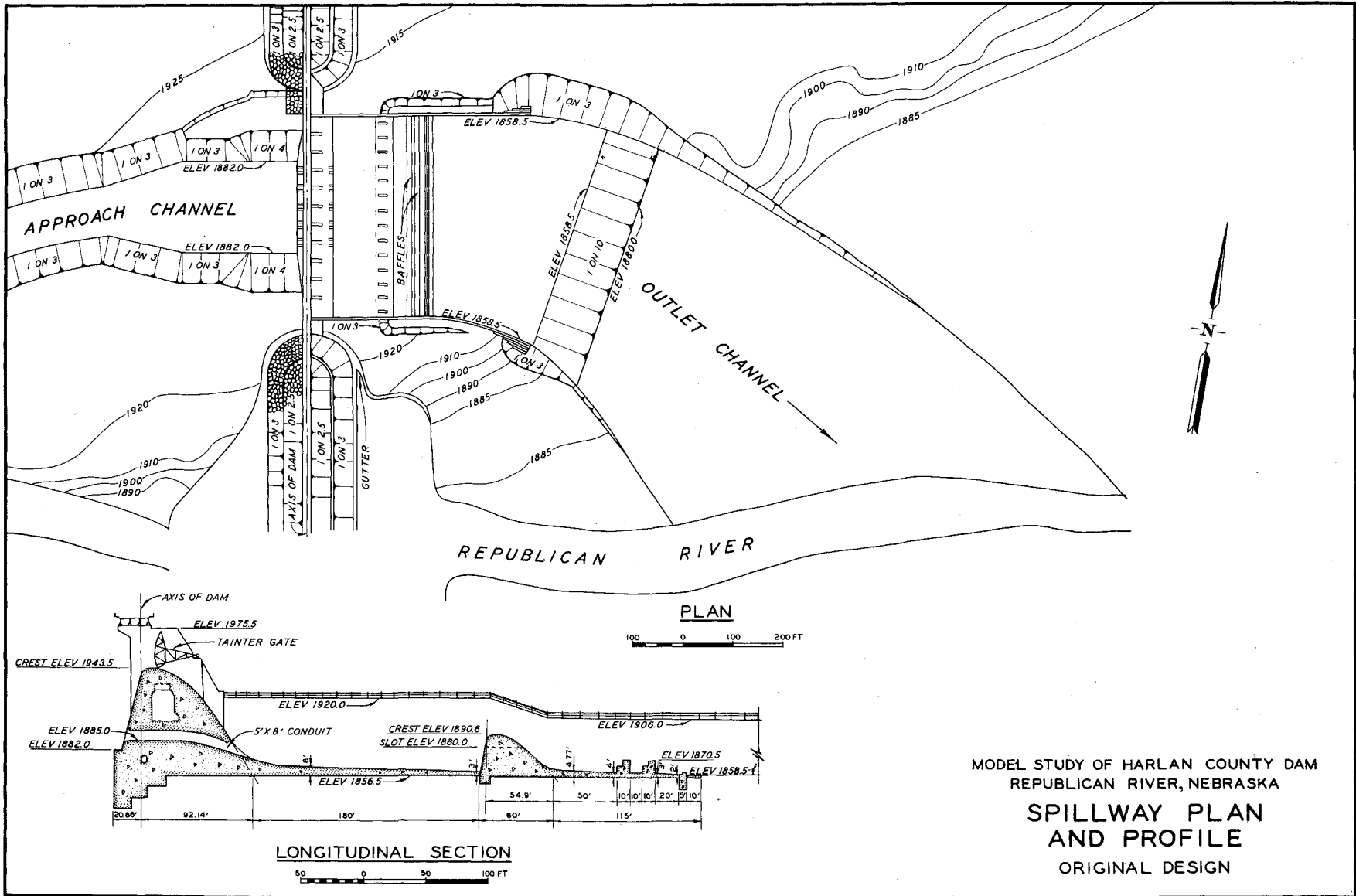
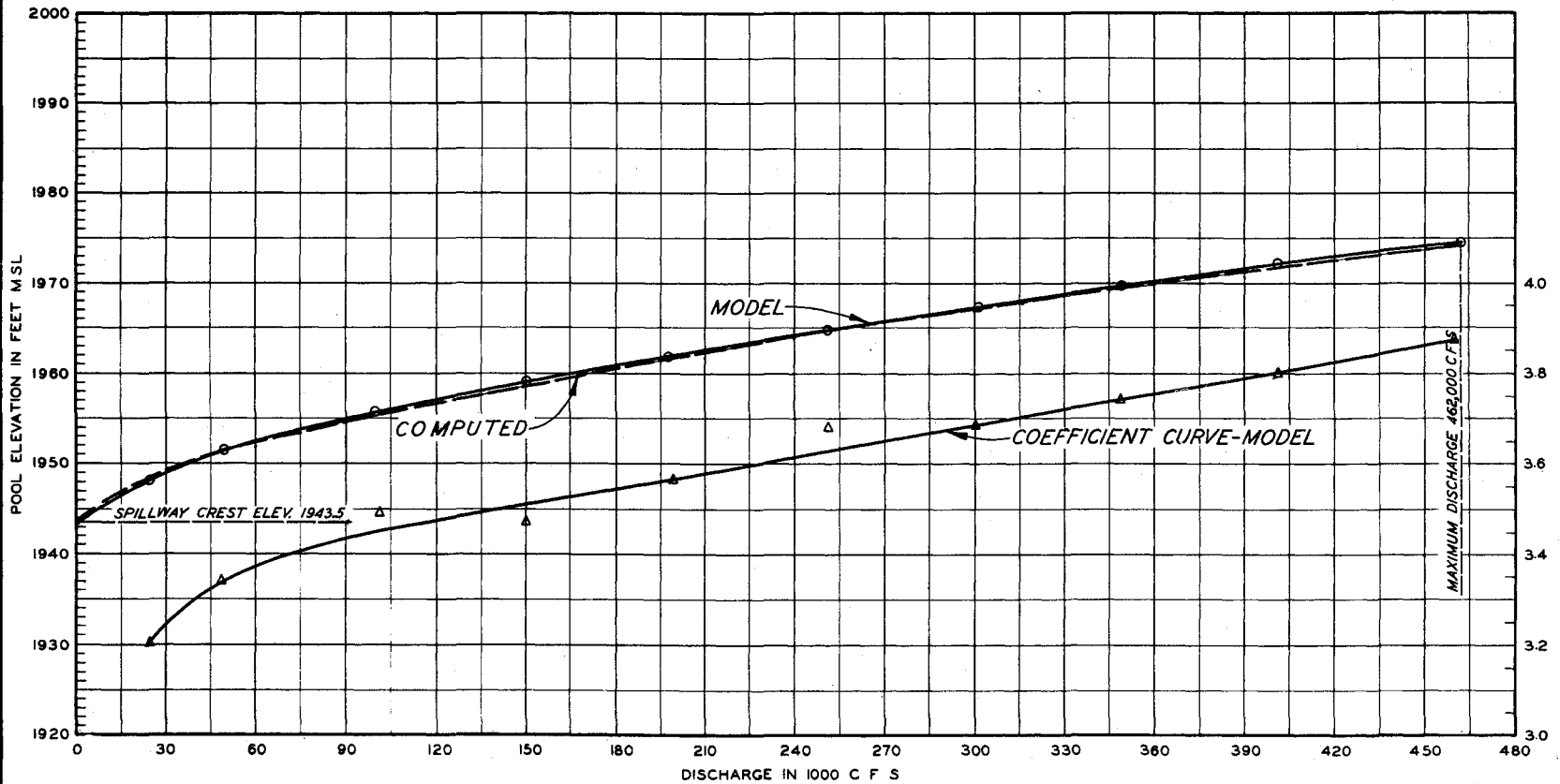
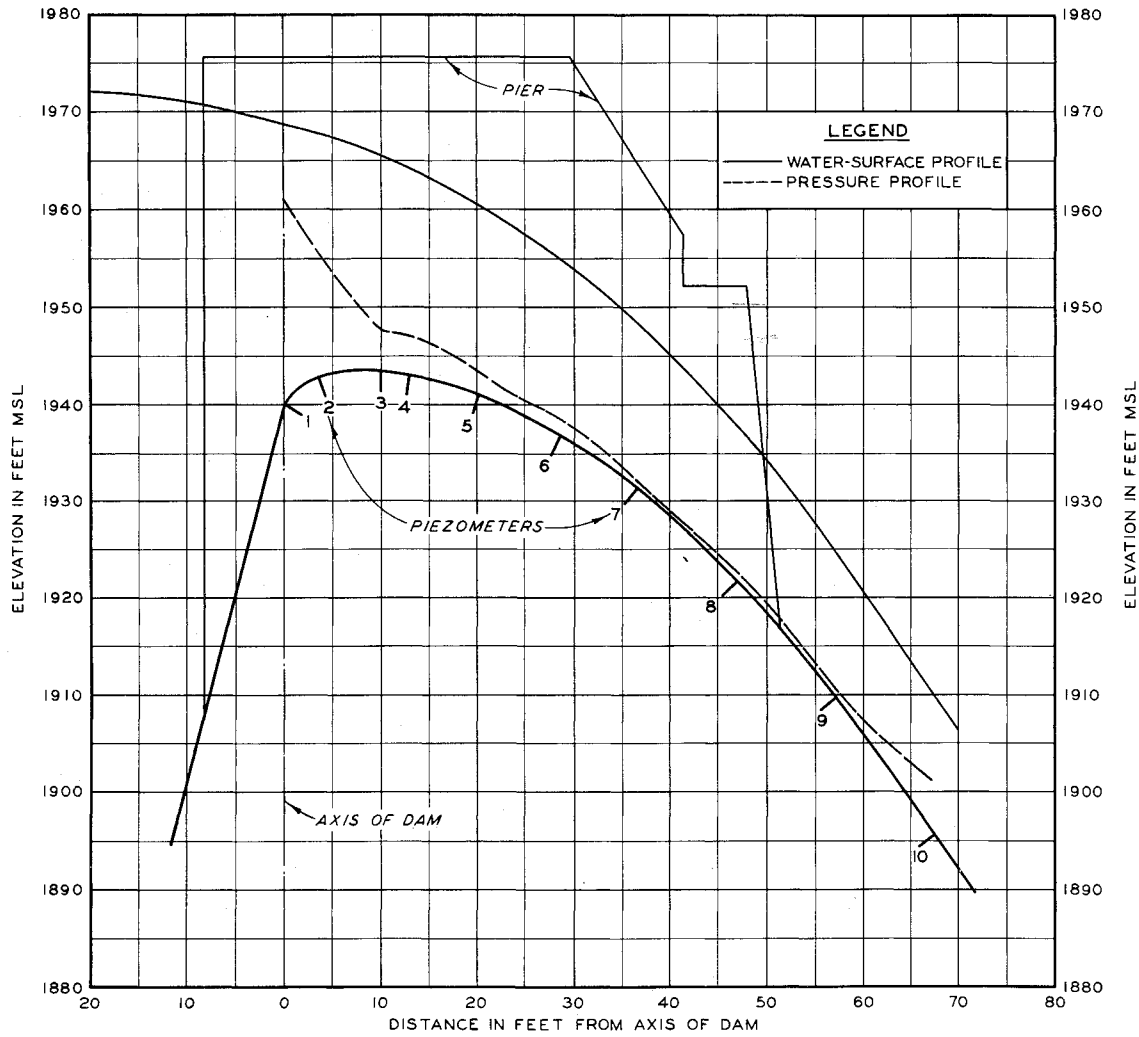

PLATE 1



MODEL STUDY OF HARLAN COUNTY DAM
 REPUBLICAN RIVER, NEBRASKA
SPILLWAY RATING CURVES
 ORIGINAL DESIGN



PIEZ. NO.	PIEZ. ZERO	PIEZ. READING	PRESSURE
1	1939.96	1962.0	22.0
3	1943.50	1947.5	4.0
4	1943.12	1947.0	4.0
5	1941.04	1943.5	2.5
6	1936.88	1938.5	1.5
7	1931.28	1932.0	0.5
8	1921.76	1922.5	0.5
9	1909.76	1910.5	0.5
10	1895.60	1901.0	5.5

NOTE: PRESSURES ARE RECORDED IN FEET OF WATER IN PROTOTYPE, TO THE NEAREST 0.5 FOOT.

MODEL STUDY OF HARLAN COUNTY DAM
REPUBLICAN RIVER, NEBRASKA

**WATER-SURFACE AND
PRESSURE PROFILES
ORIGINAL DESIGN**

DISCHARGE 462,000 C F S
TAILWATER ELEV. 1899.5

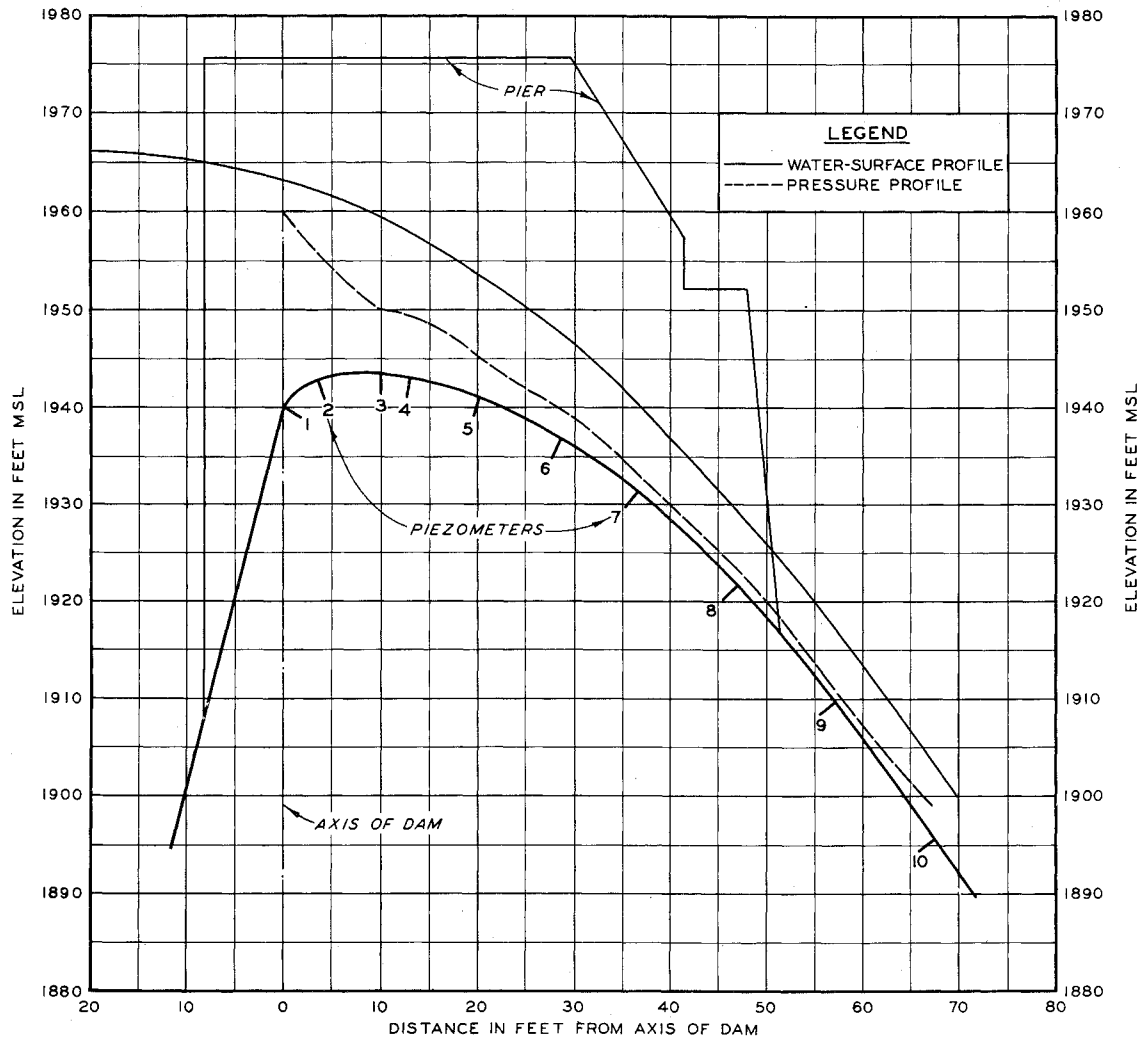

PIEZ. NO.	PIEZ. ZERO	PIEZ. READING	PRESSURE
1	1939.96	1960.0	20.0
3	1943.50	1950.0	6.5
4	1943.12	1949.5	6.5
5	1941.04	1945.0	4.0
6	1936.88	1940.0	3.0
7	1931.28	1933.0	1.5
8	1921.76	1923.5	1.5
9	1909.76	1911.0	1.0
10	1895.60	1899.0	3.5

NOTE: PRESSURES ARE RECORDED IN FEET OF WATER IN PROTOTYPE, TO THE NEAREST 0.5 FOOT.

MODEL STUDY OF HARLAN COUNTY DAM
 REPUBLICAN RIVER, NEBRASKA
**WATER-SURFACE AND
 PRESSURE PROFILES**
 ORIGINAL DESIGN

DISCHARGE 300,000 C F S
 TAILWATER ELEV. 1896.5

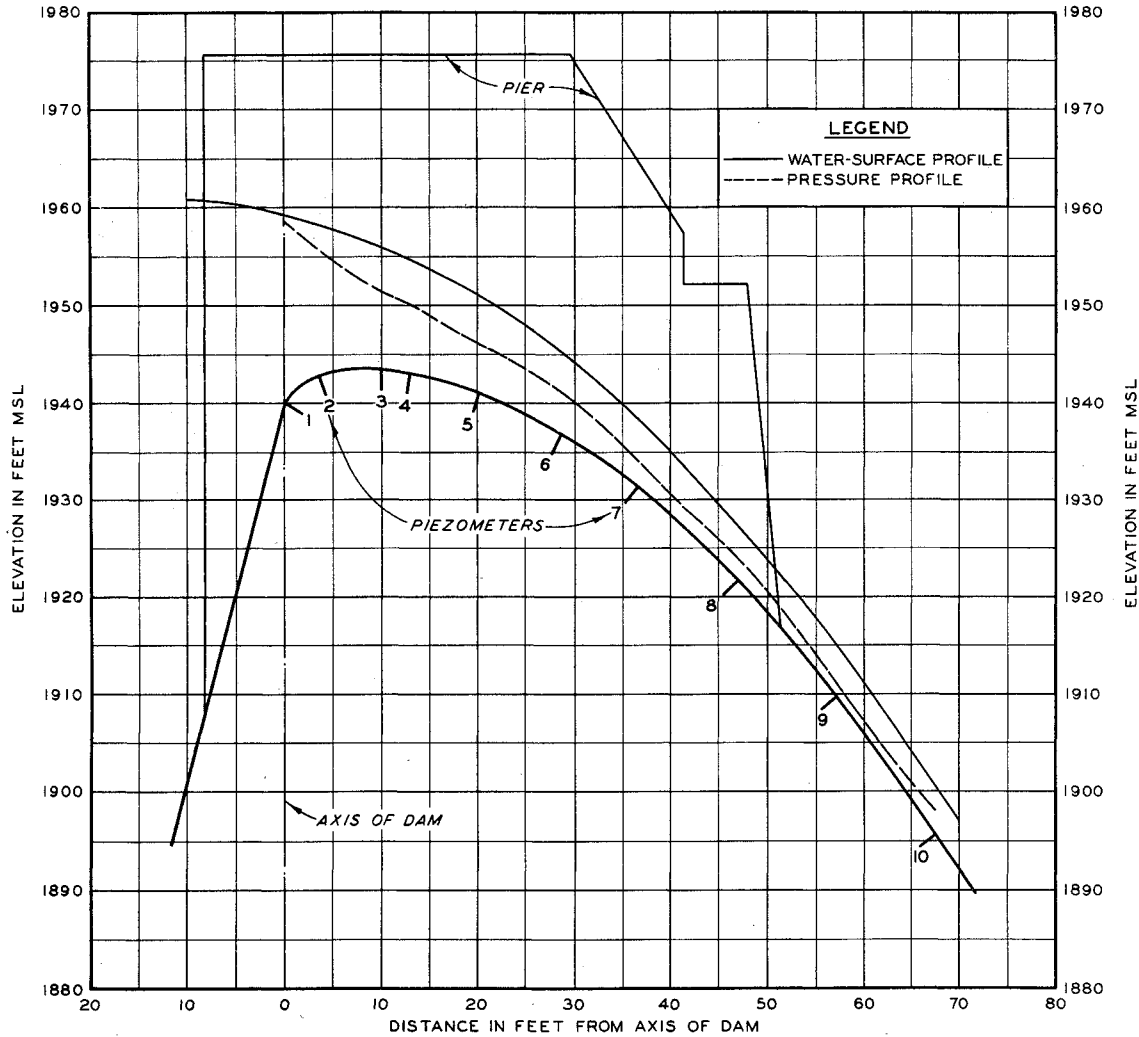

PIEZ. NO.	PIEZ. ZERO	PIEZ. READING	PRESSURE
1	1939.96	1958.5	18.5
3	1943.50	1951.0	7.5
4	1943.12	1950.0	7.0
5	1941.04	1946.0	5.0
6	1936.88	1941.0	4.0
7	1931.28	1934.0	2.5
8	1921.76	1924.0	2.0
9	1909.76	1911.0	1.0
10	1895.60	1898.0	2.5

NOTE: PRESSURES ARE RECORDED IN FEET OF WATER IN PROTOTYPE, TO THE NEAREST 0.5 FOOT.

MODEL STUDY OF HARLAN COUNTY DAM
 REPUBLICAN RIVER, NEBRASKA
**WATER-SURFACE AND
 PRESSURE PROFILES**
 ORIGINAL DESIGN

DISCHARGE 200,000 CFS
 TAILWATER ELEV. 1894.5

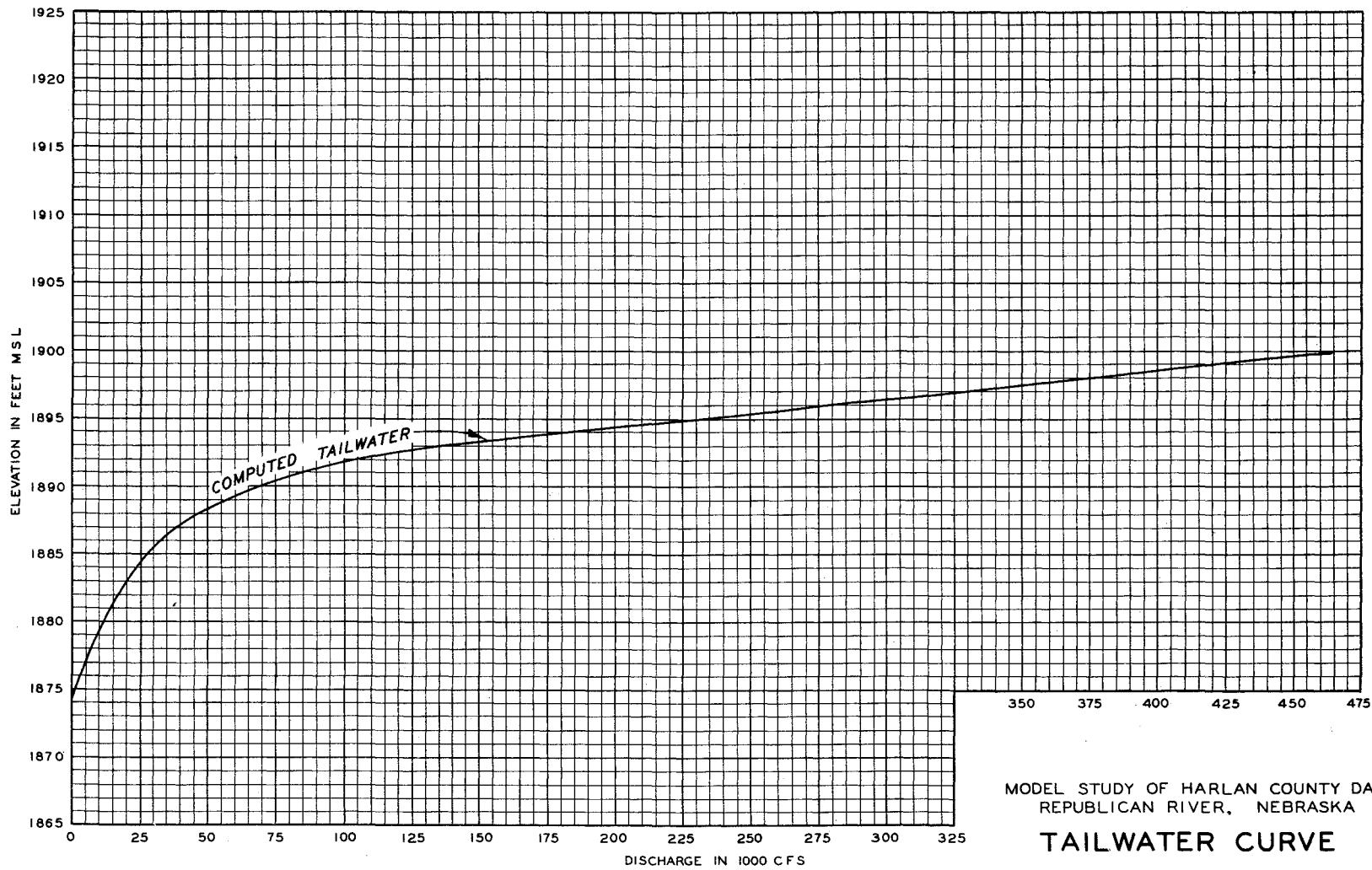

MODEL STUDY OF HARLAN COUNTY DAM
REPUBLICAN RIVER, NEBRASKA

TAILWATER CURVE

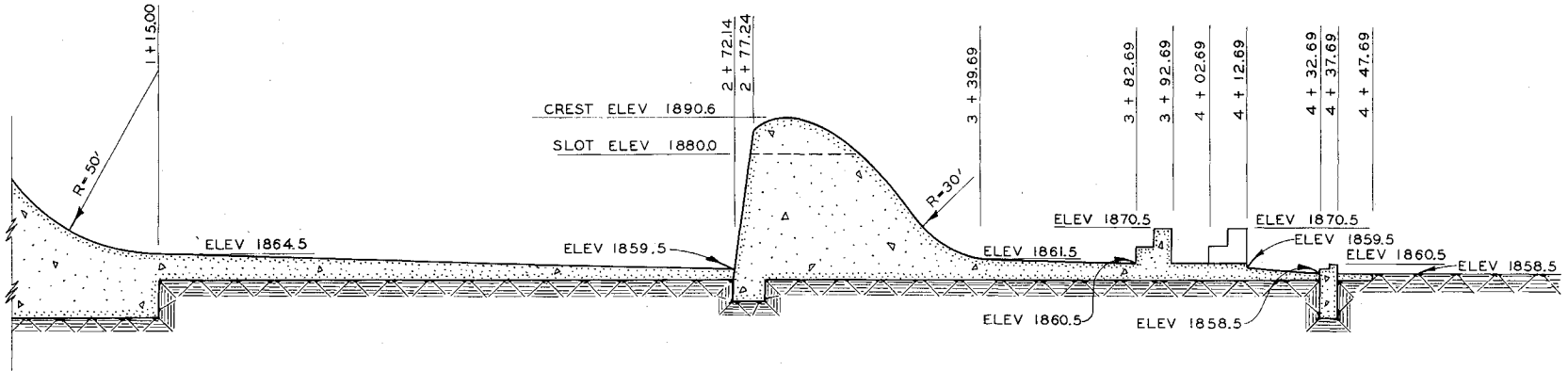

PROFILE

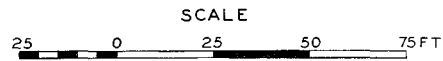

NOTE: ELEVATIONS ARE IN FEET REFERRED TO M.S.L.

MODEL STUDY OF HARLAN COUNTY DAM
REPUBLICAN RIVER, NEBRASKA

ORIGINAL DESIGN
STILLING BASIN

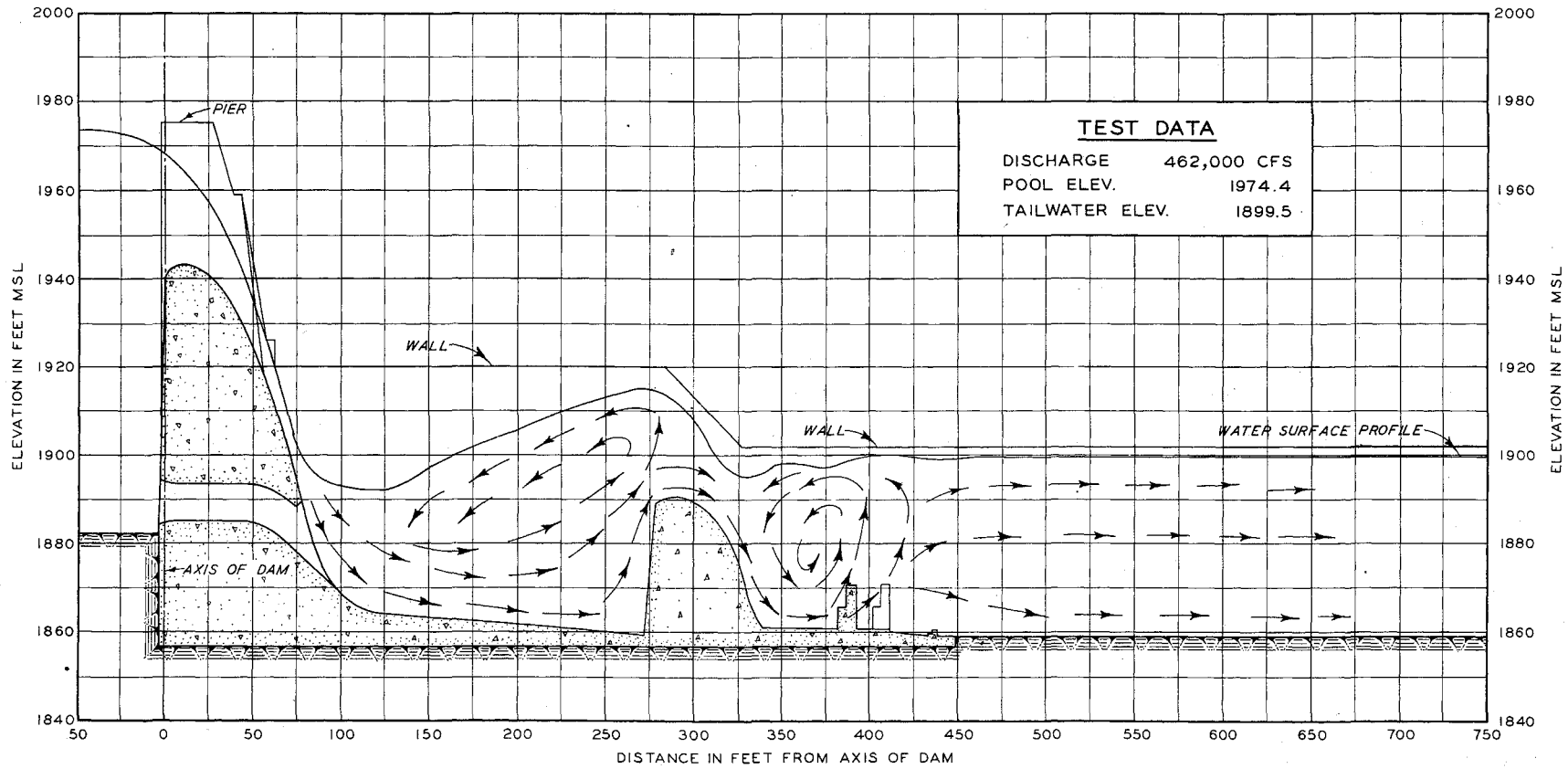

NOTE: WATER-SURFACE PROFILES MEASURED ALONG CENTERLINE OF SPILLWAY.

MODEL STUDY OF HARLAN COUNTY DAM
 REPUBLICAN RIVER, NEBRASKA
WATER-SURFACE PROFILE
 ORIGINAL DESIGN

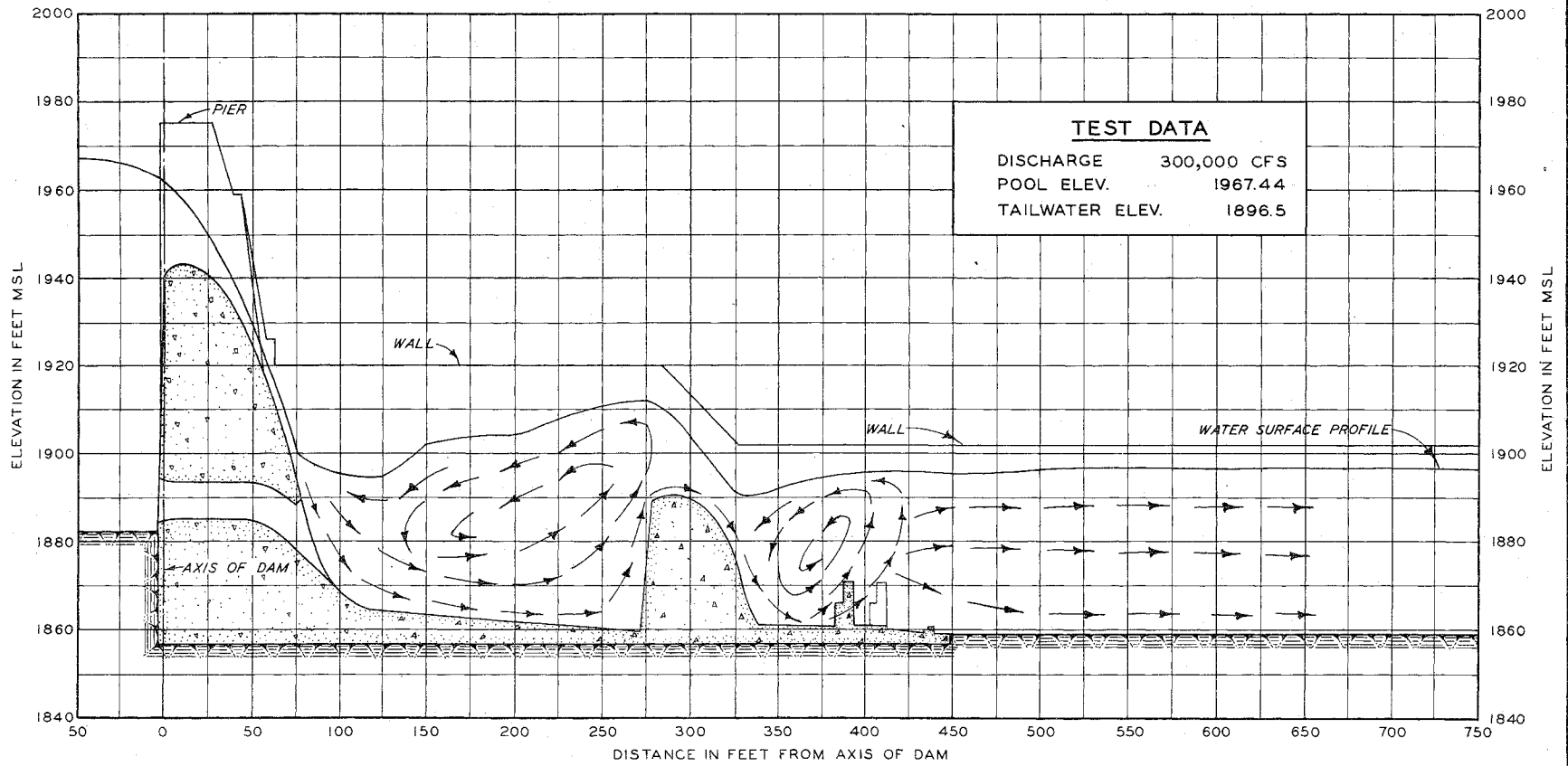

NOTE: WATER-SURFACE PROFILES MEASURED ALONG CENTERLINE OF SPILLWAY.

MODEL STUDY OF HARLAN COUNTY DAM
REPUBLICAN RIVER, NEBRASKA

**WATER-SURFACE PROFILE
ORIGINAL DESIGN**

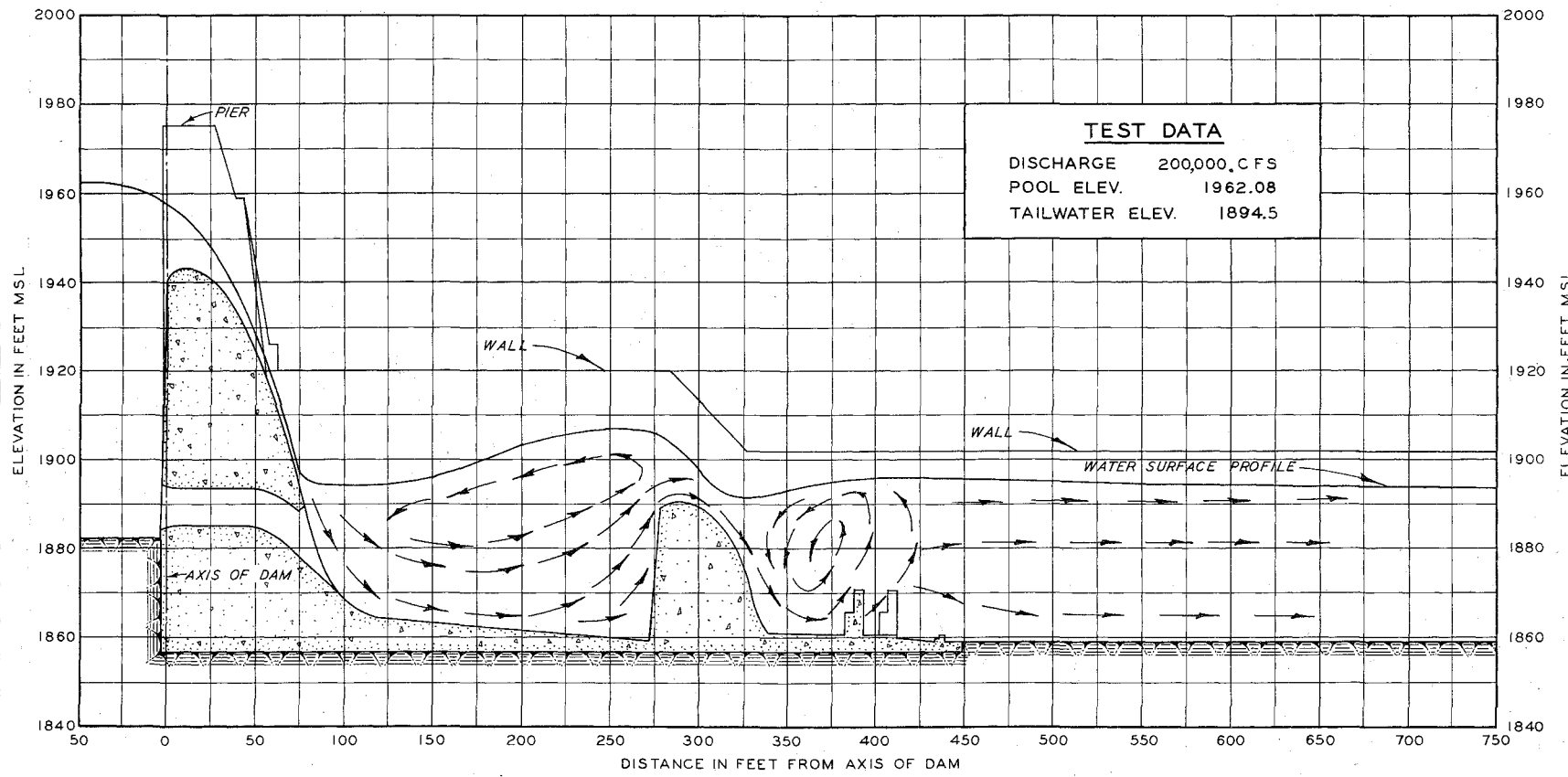

NOTE: WATER-SURFACE PROFILES MEASURED ALONG CENTERLINE OF SPILLWAY.

MODEL STUDY OF HARLAN COUNTY DAM
 REPUBLICAN RIVER, NEBRASKA
WATER-SURFACE PROFILE
 ORIGINAL DESIGN

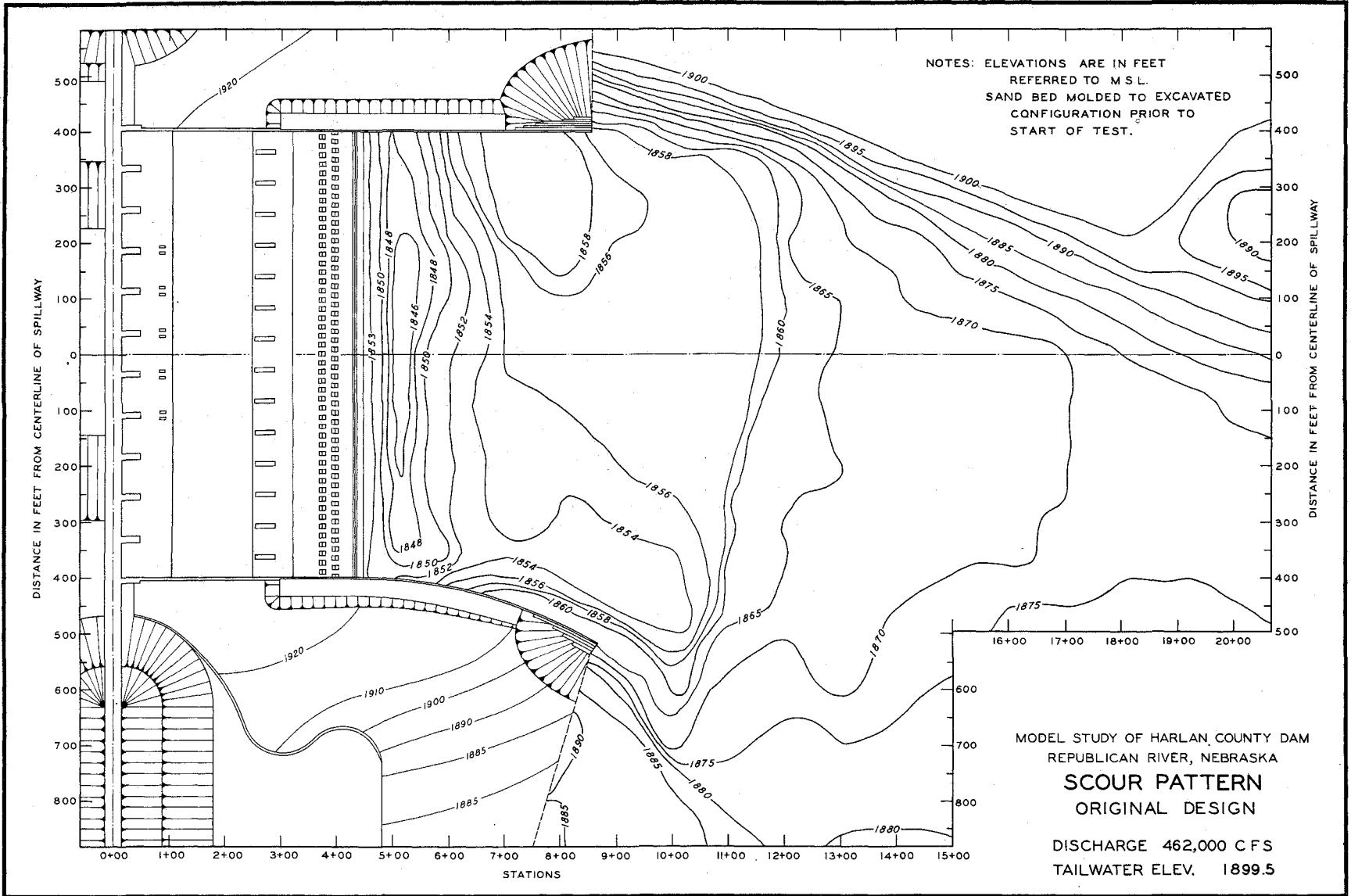

NOTES: ELEVATIONS ARE IN FEET
REFERRED TO M.S.L.
SAND BED MOLDED TO EXCAVATED
CONFIGURATION PRIOR TO
START OF TEST.

MODEL STUDY OF HARLAN, COUNTY DAM
REPUBLICAN RIVER, NEBRASKA
SCOUR PATTERN
ORIGINAL DESIGN
DISCHARGE 462,000 CFS
TAILWATER ELEV. 1899.5

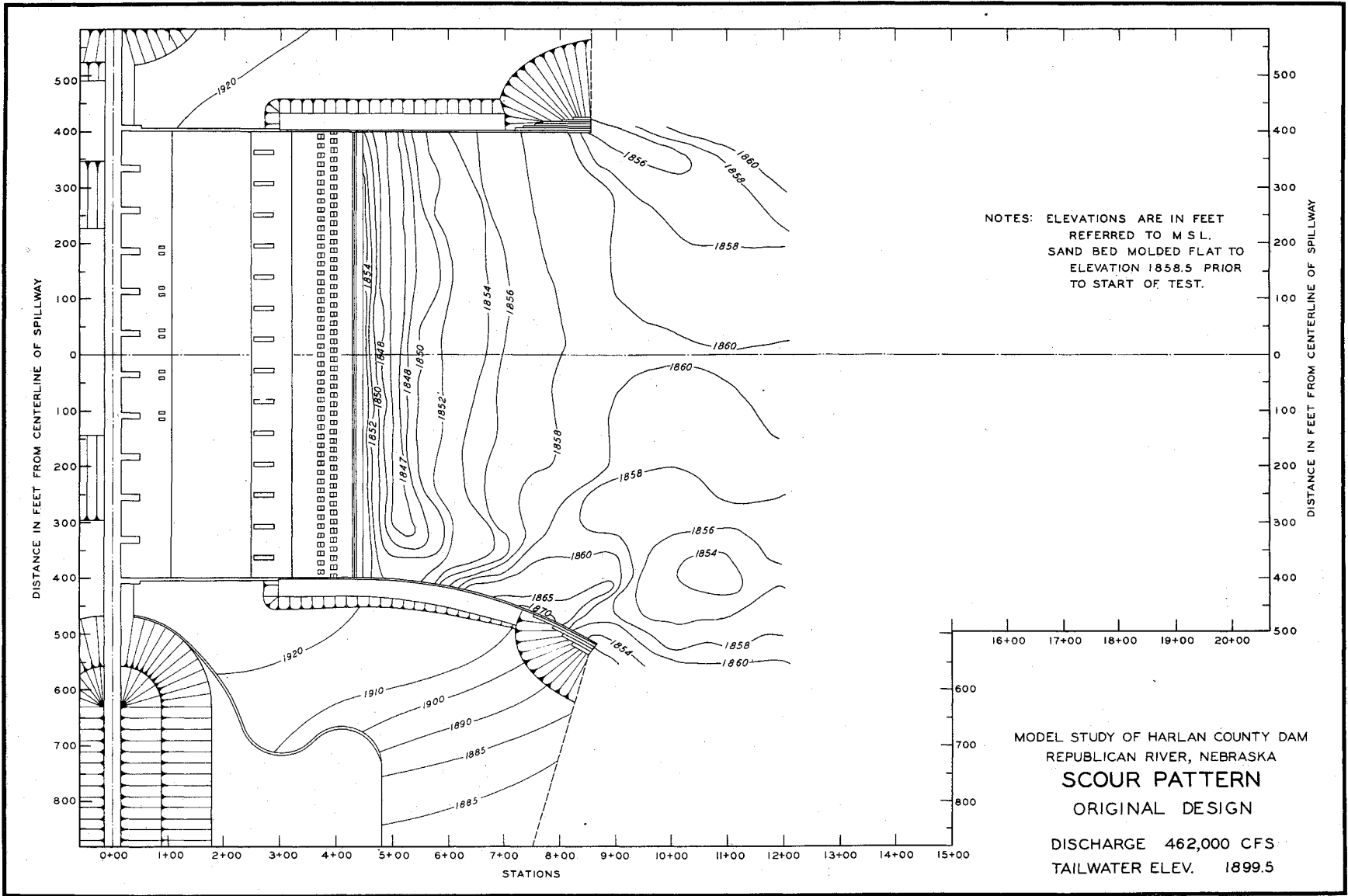

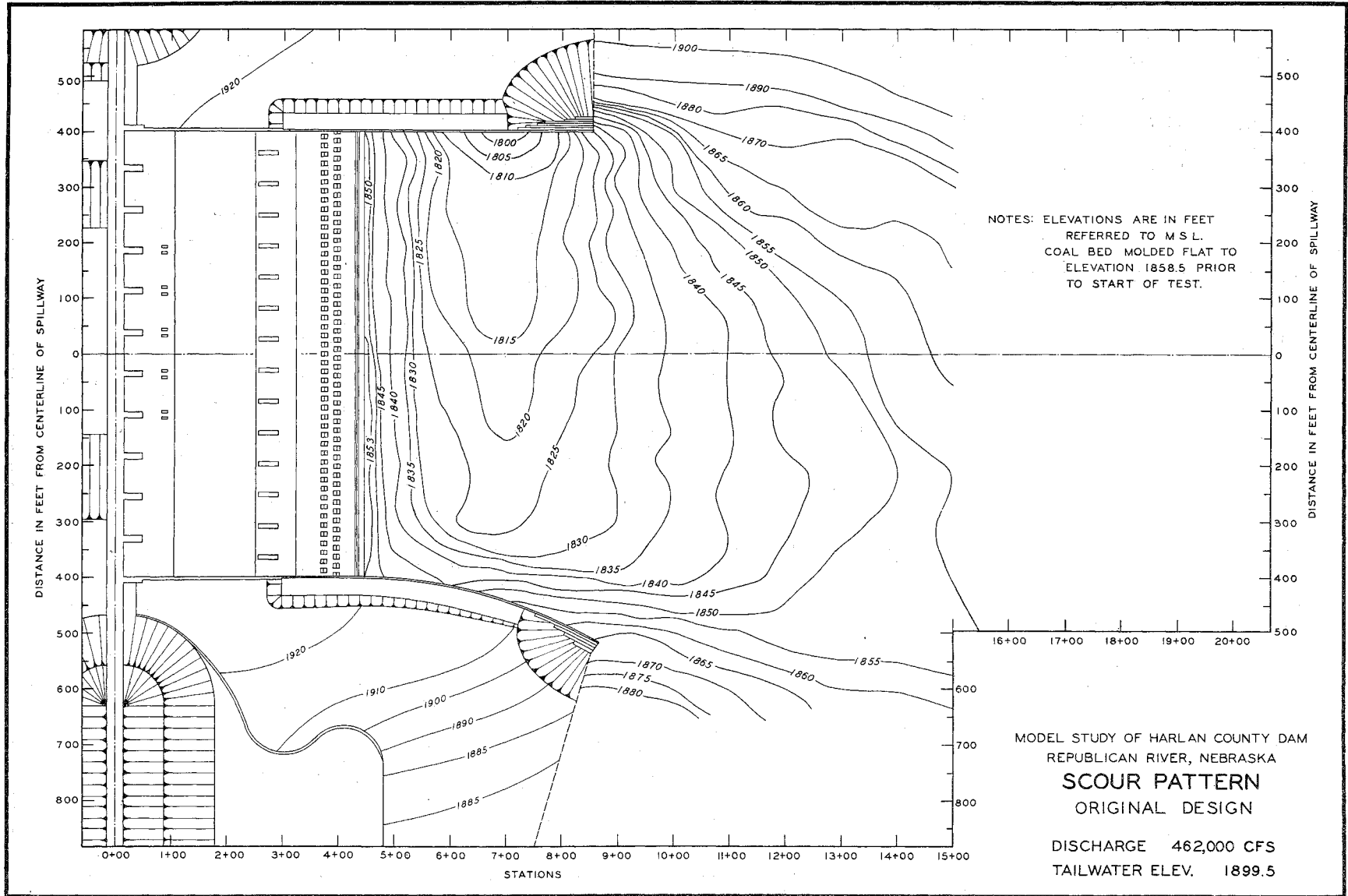

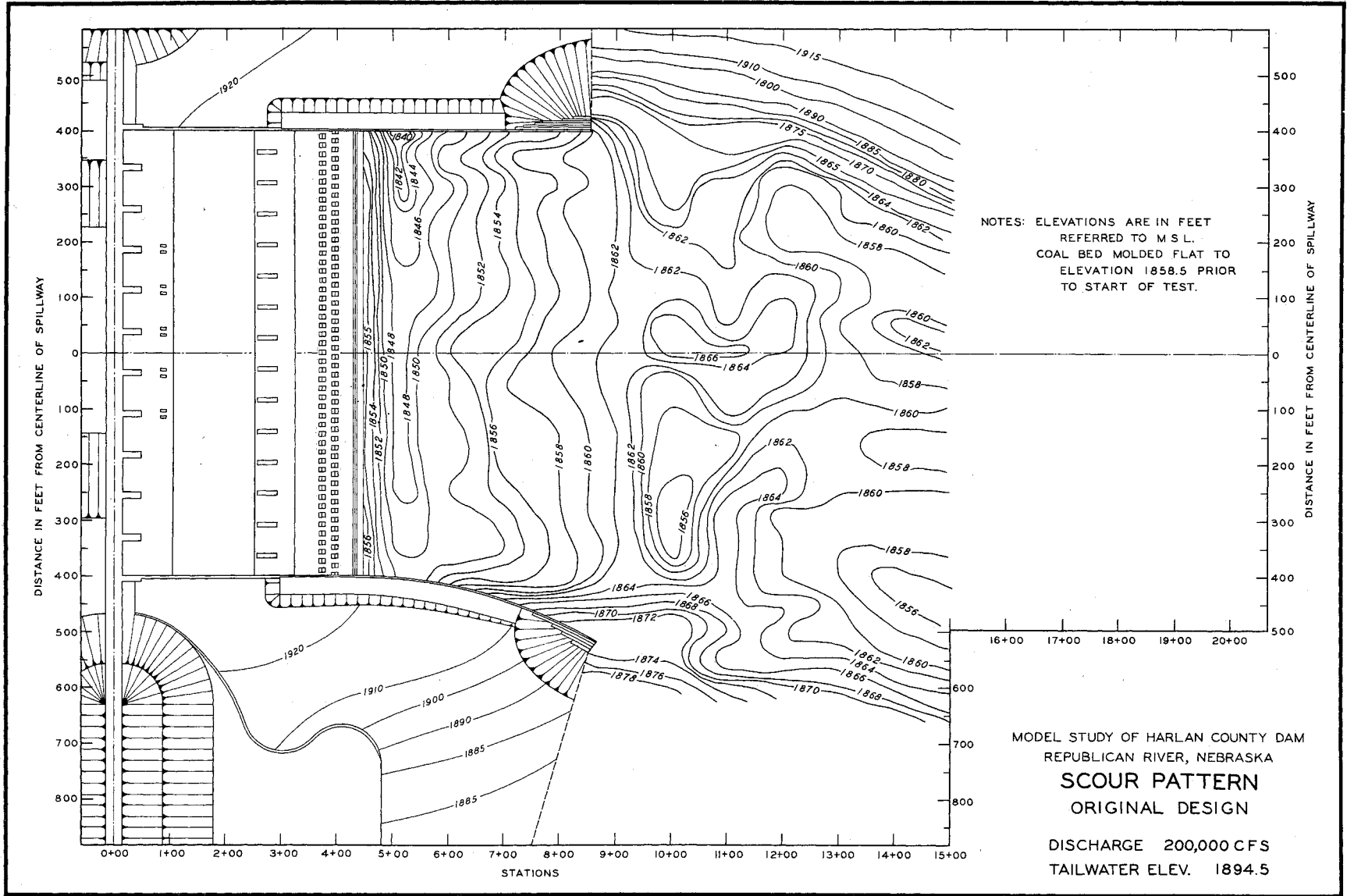

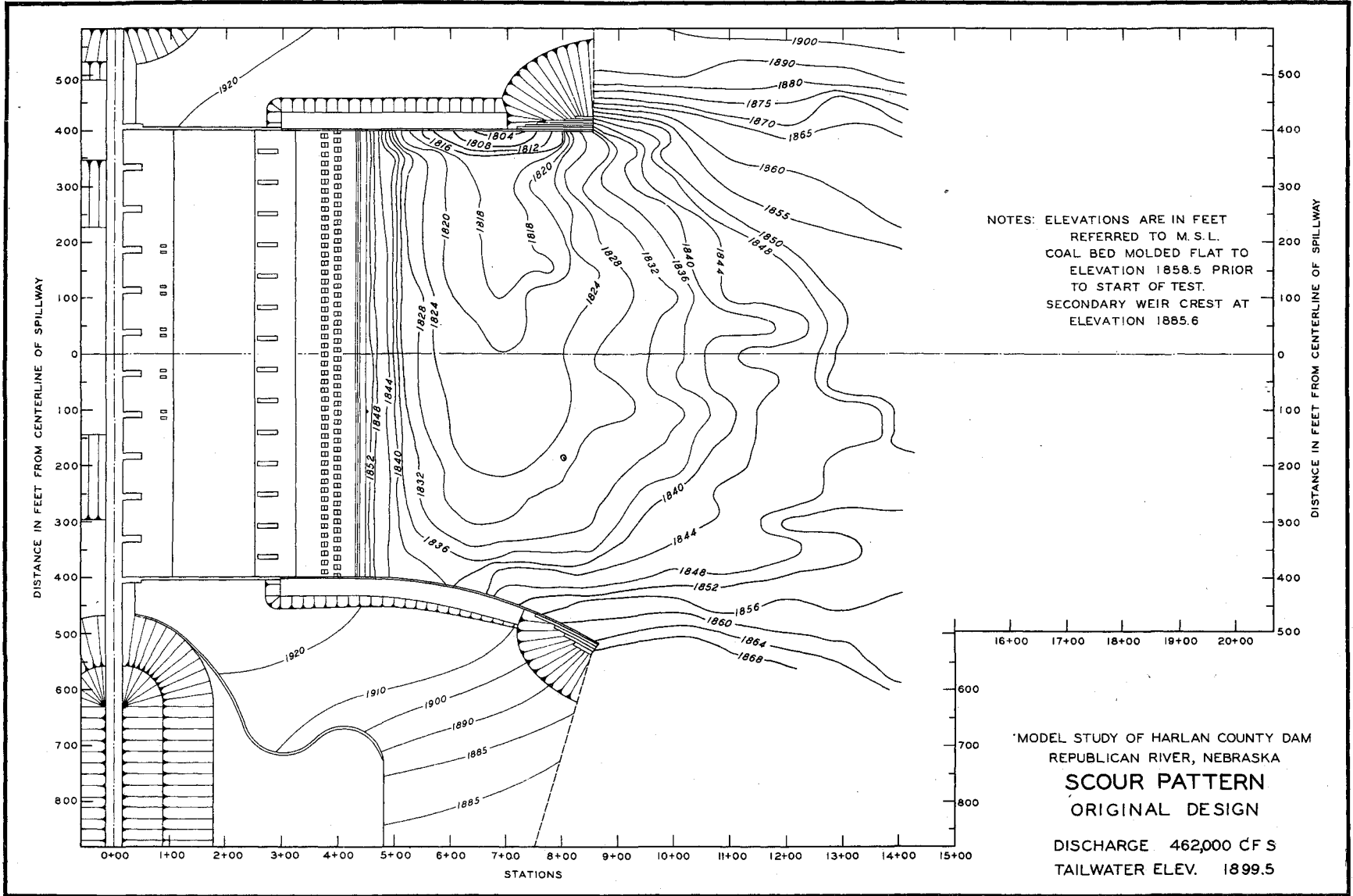

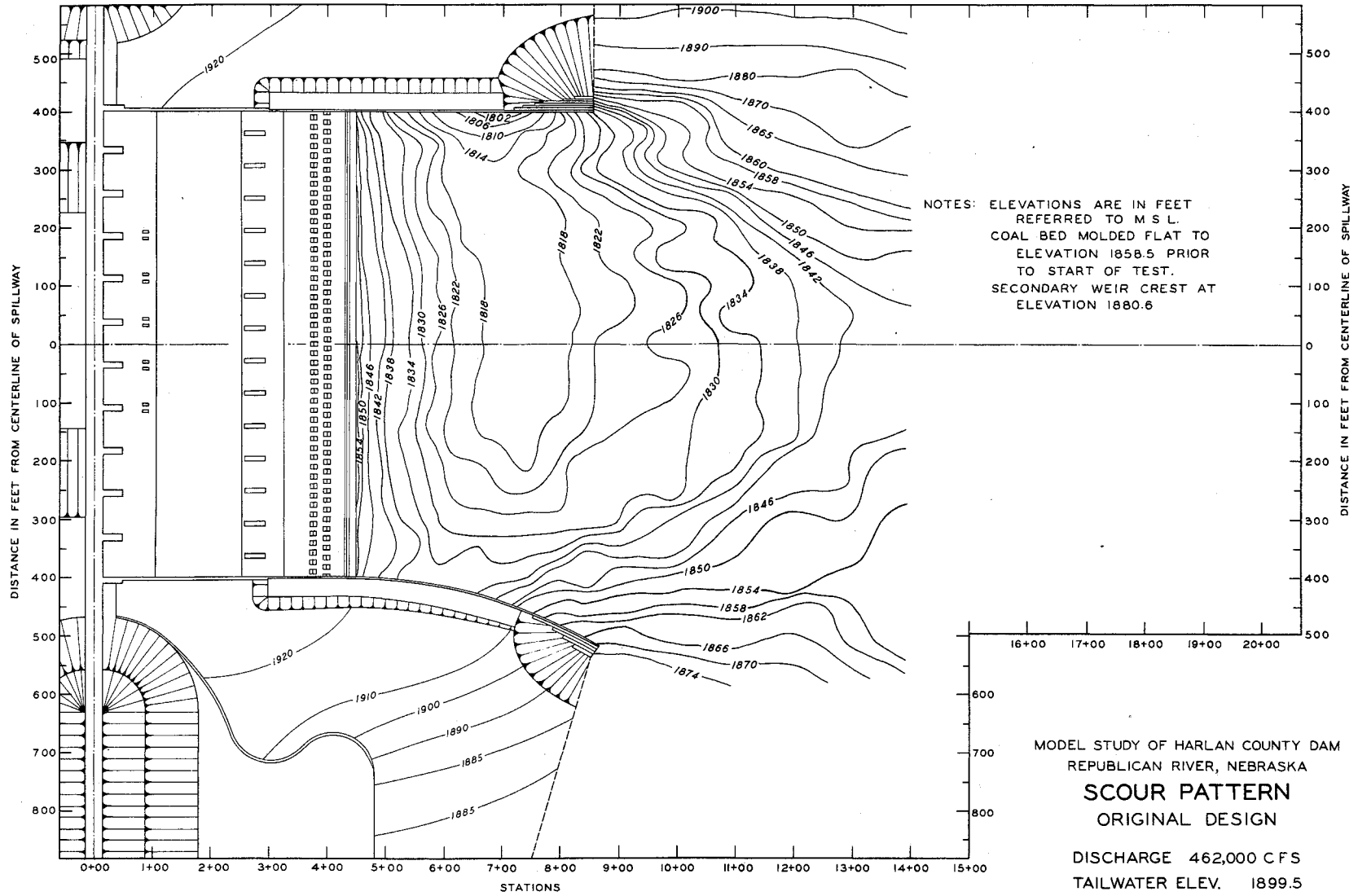

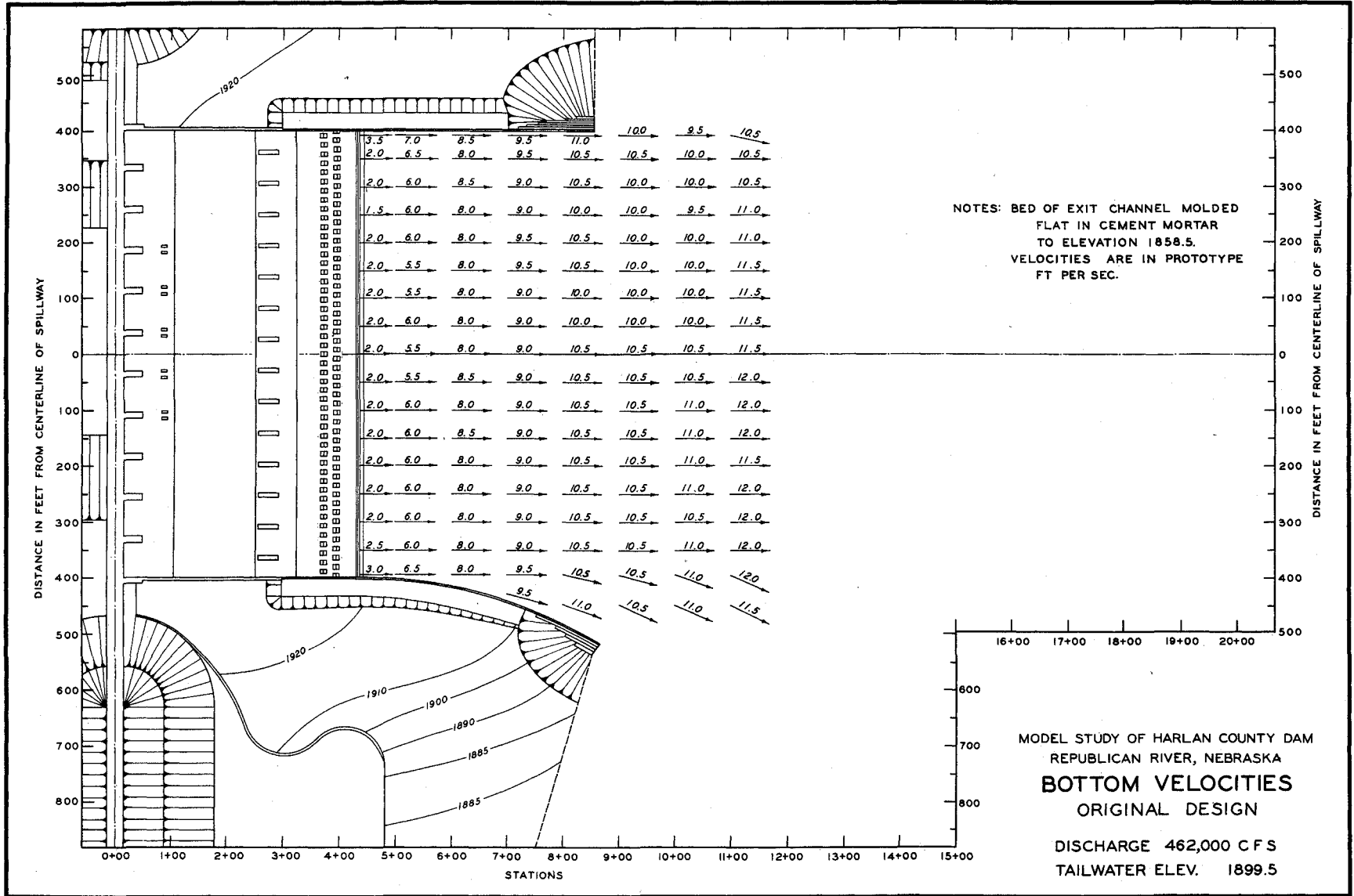

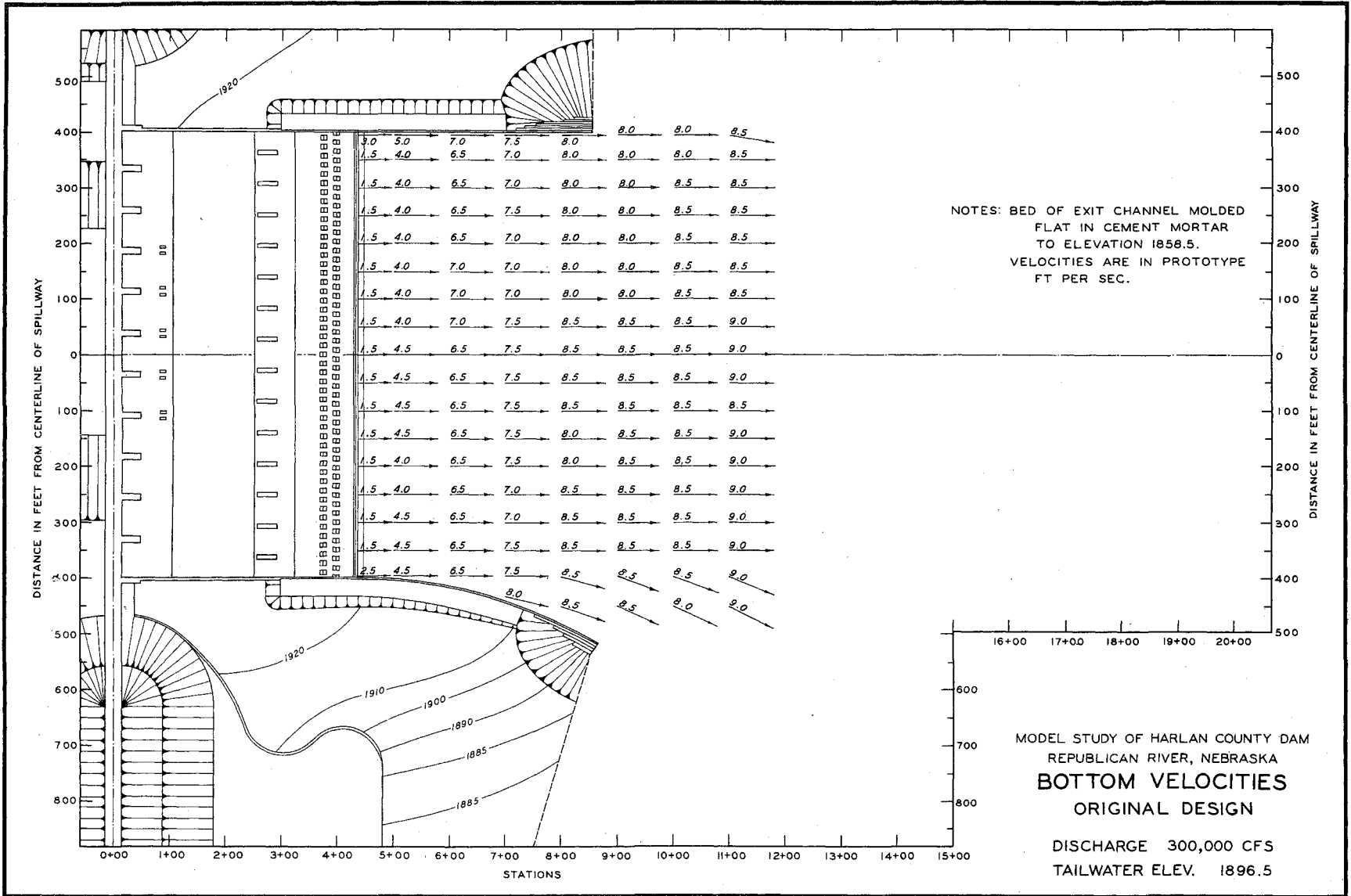

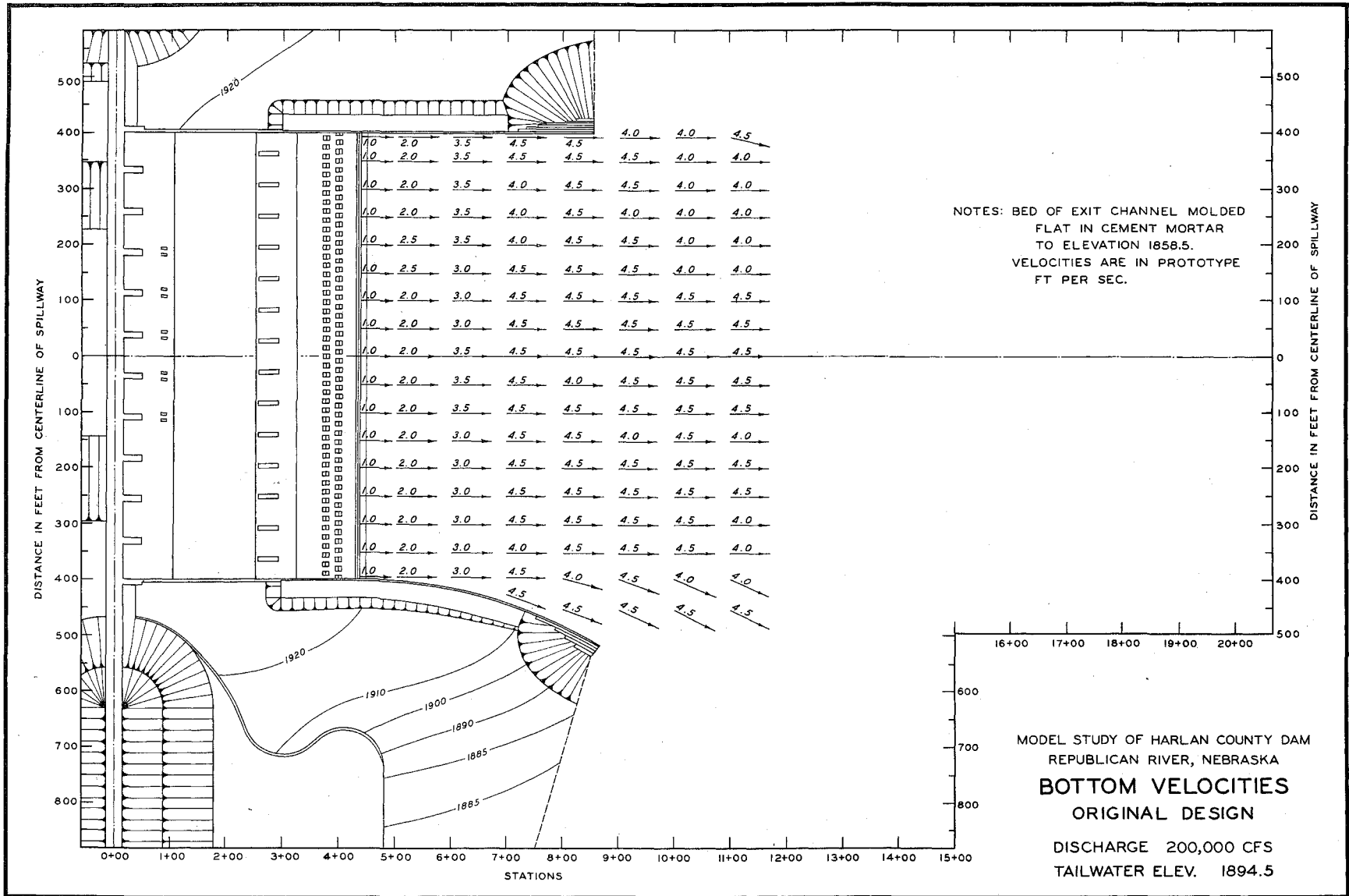

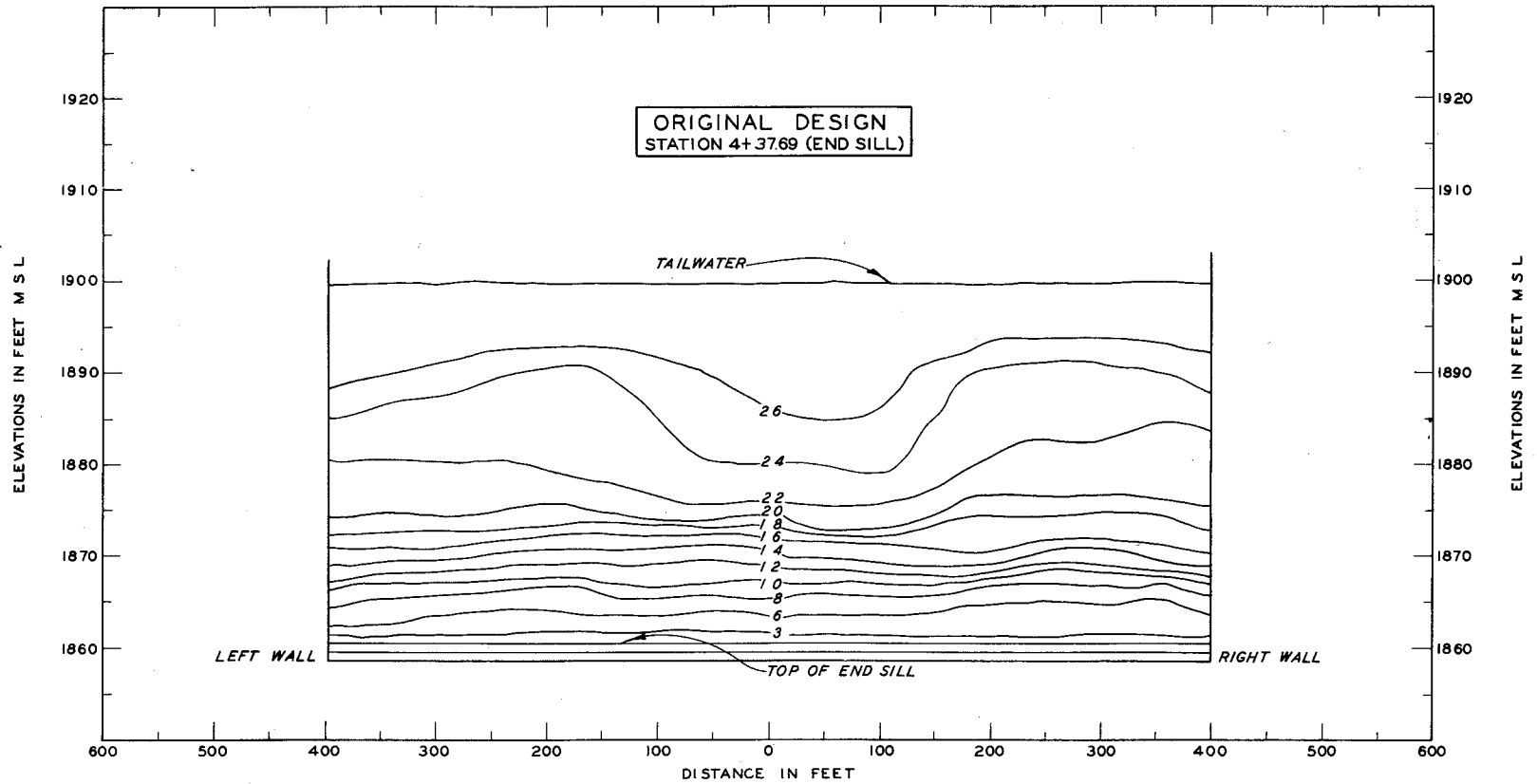

NOTE: VELOCITIES ARE IN PROTOTYPE FT PER SEC.

MODEL STUDY OF HARLAN COUNTY DAM
REPUBLICAN RIVER, NEBRASKA

VELOCITY DISTRIBUTION
AT END SILL

DISCHARGE 462,000 CFS
TAILWATER ELEV. 1899.5

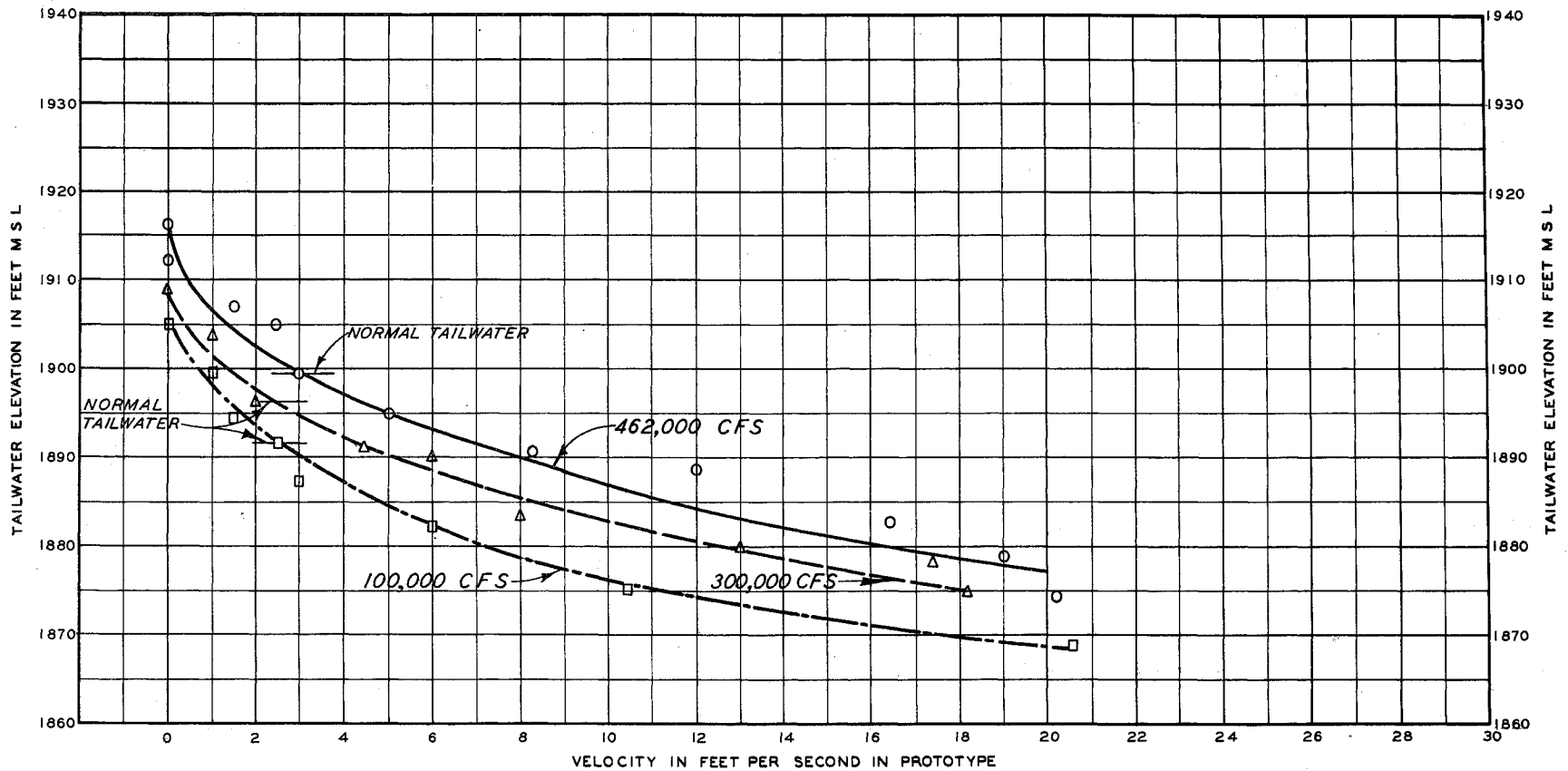

NOTES: VELOCITIES MEASURED 1.0 FT ABOVE END SILL . STA. 4 + 37.69
 END SILL AT ELEVATION 1860.5
 ALL BASIN ELEMENTS REMAINED ON APRON.

MODEL STUDY OF HARLAN COUNTY DAM
 REPUBLICAN RIVER, NEBRASKA
VELOCITY-TAILWATER CURVES
 ORIGINAL DESIGN

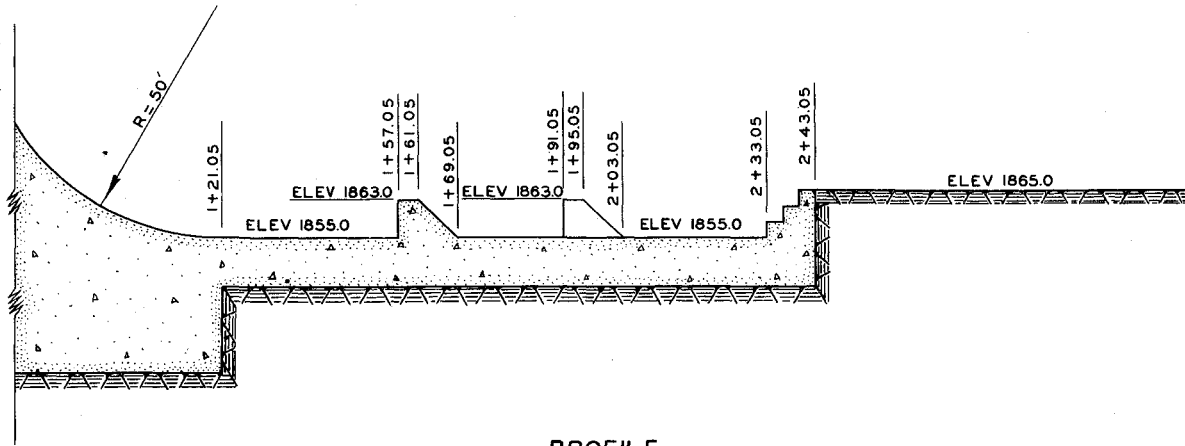

PROFILE

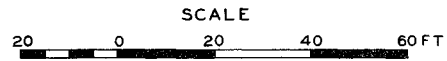

NOTE: ELEVATIONS ARE IN FEET REFERRED TO MSL.

MODEL STUDY OF HARLAN COUNTY DAM
REPUBLICAN RIVER, NEBRASKA

**TYPE I DESIGN
STILLING BASIN**

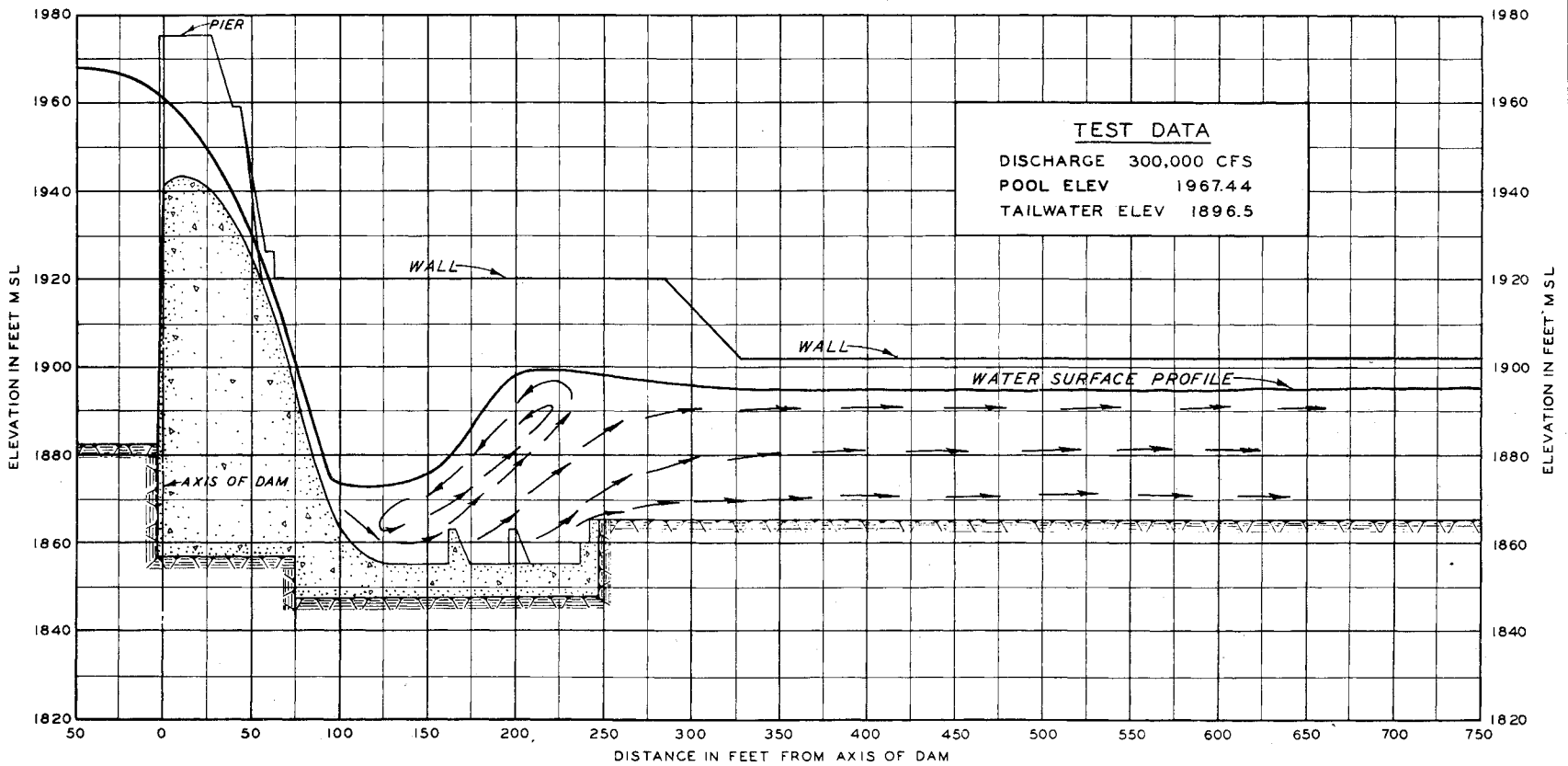

NOTE: WATER-SURFACE PROFILES MEASURED ALONG CENTERLINE OF SPILLWAY.

MODEL STUDY OF HARLAN COUNTY DAM
 REPUBLICAN RIVER, NEBRASKA
WATER-SURFACE PROFILE
 TYPE I DESIGN

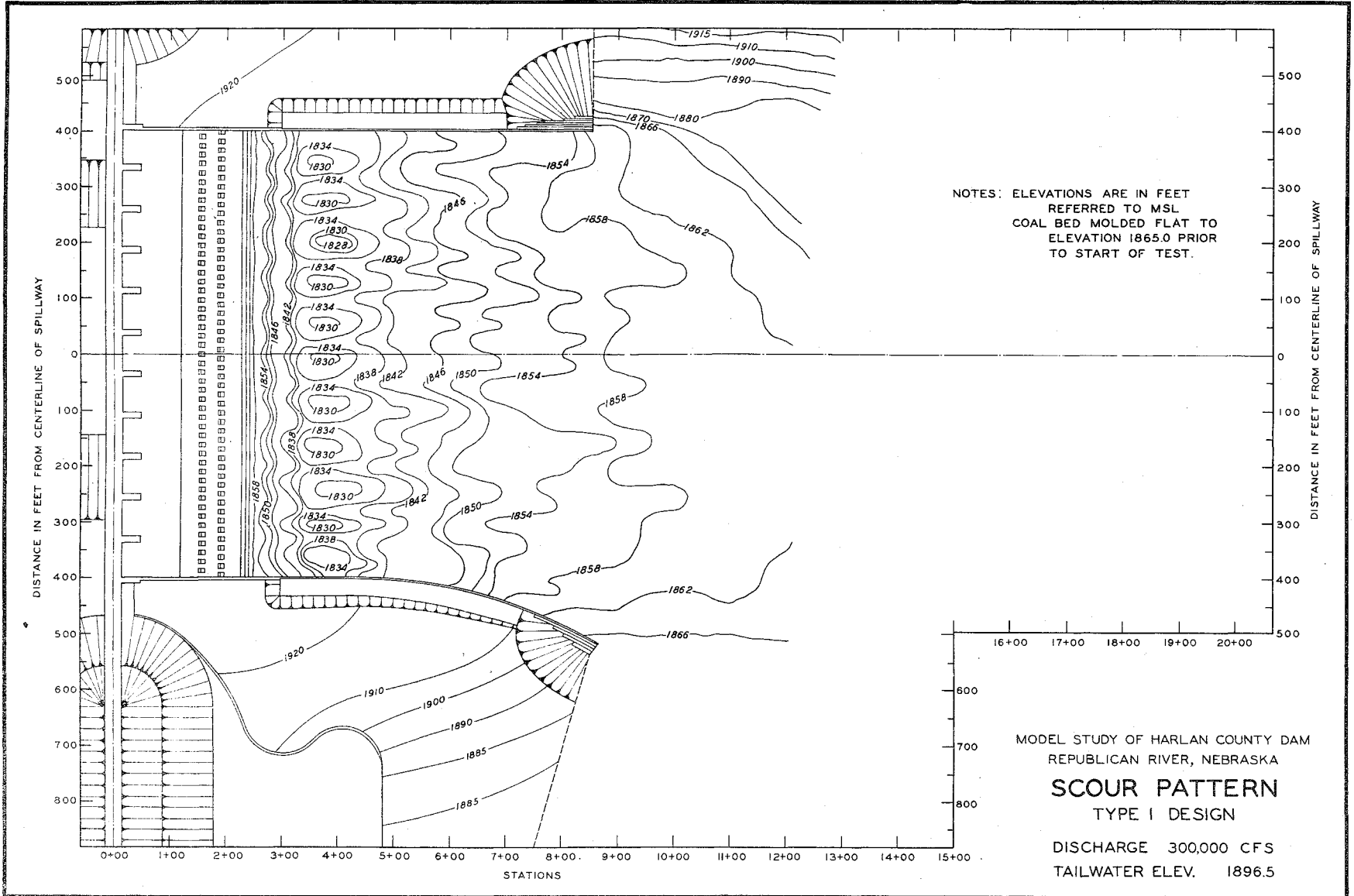

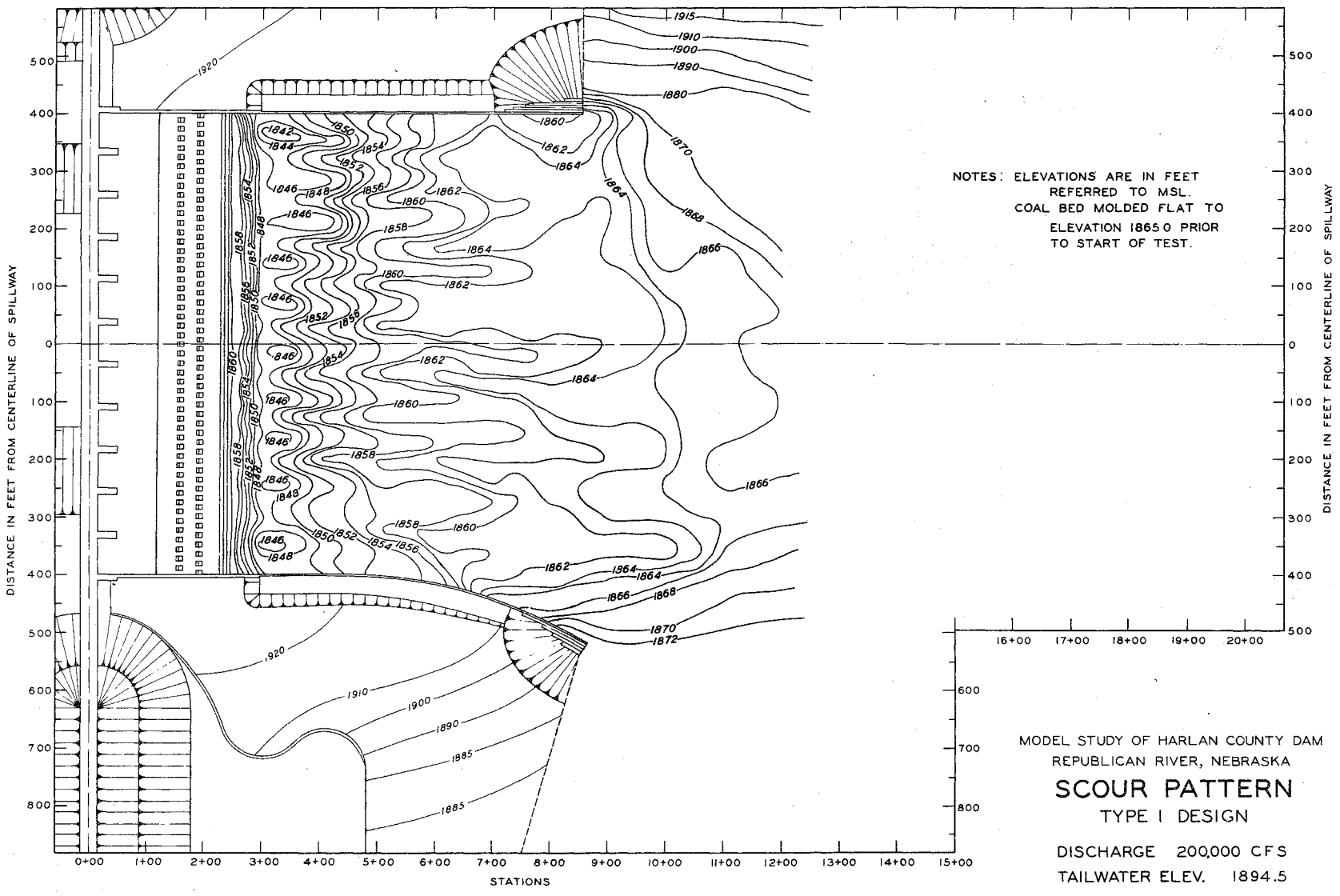

NOTES: ELEVATIONS ARE IN FEET
 REFERRED TO MSL.
 COAL BED MOLDED FLAT TO
 ELEVATION 1865.0 PRIOR
 TO START OF TEST.

MODEL STUDY OF HARLAN COUNTY DAM
 REPUBLICAN RIVER, NEBRASKA
SCOUR PATTERN
 TYPE I DESIGN
 DISCHARGE 200,000 CFS
 TAILWATER ELEV. 1894.5

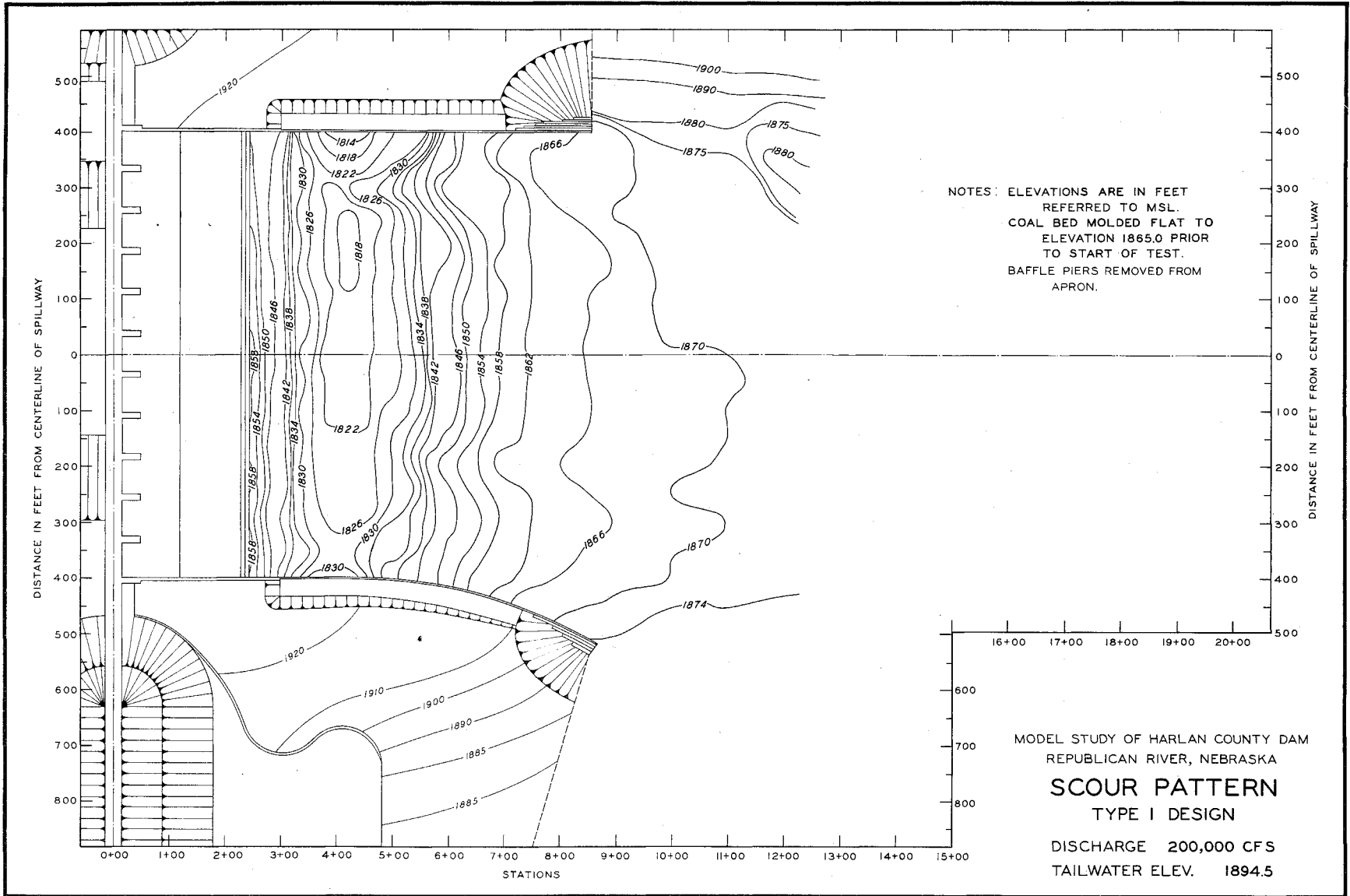

NOTES: ELEVATIONS ARE IN FEET
 REFERRED TO MSL.
 COAL BED MOLDED FLAT TO
 ELEVATION 1865.0 PRIOR
 TO START OF TEST.
 BAFFLE PIERS REMOVED FROM
 APRON.

MODEL STUDY OF HARLAN COUNTY DAM
 REPUBLICAN RIVER, NEBRASKA
SCOUR PATTERN
 TYPE I DESIGN
 DISCHARGE 200,000 CFS
 TAILWATER ELEV. 1894.5

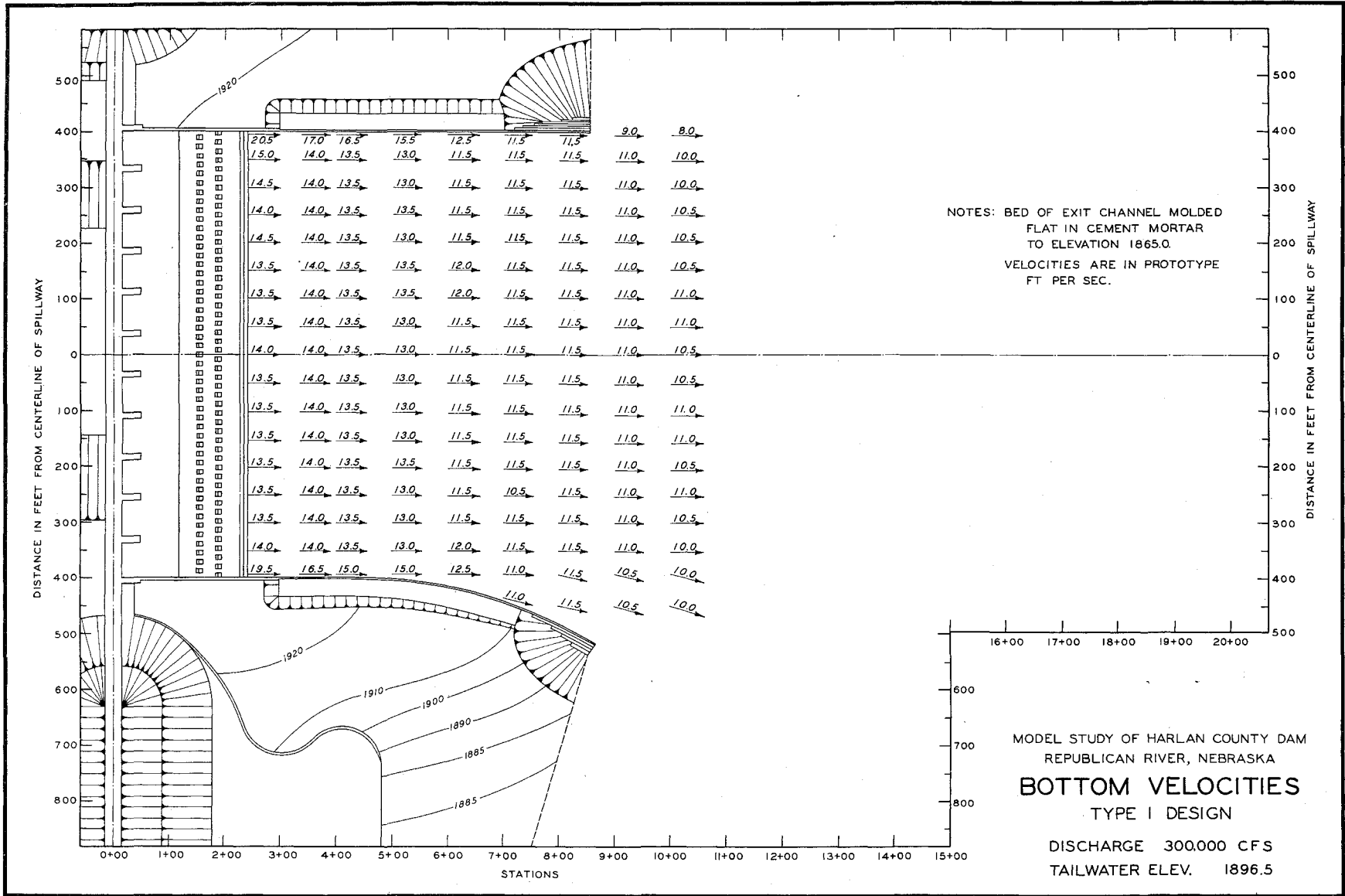

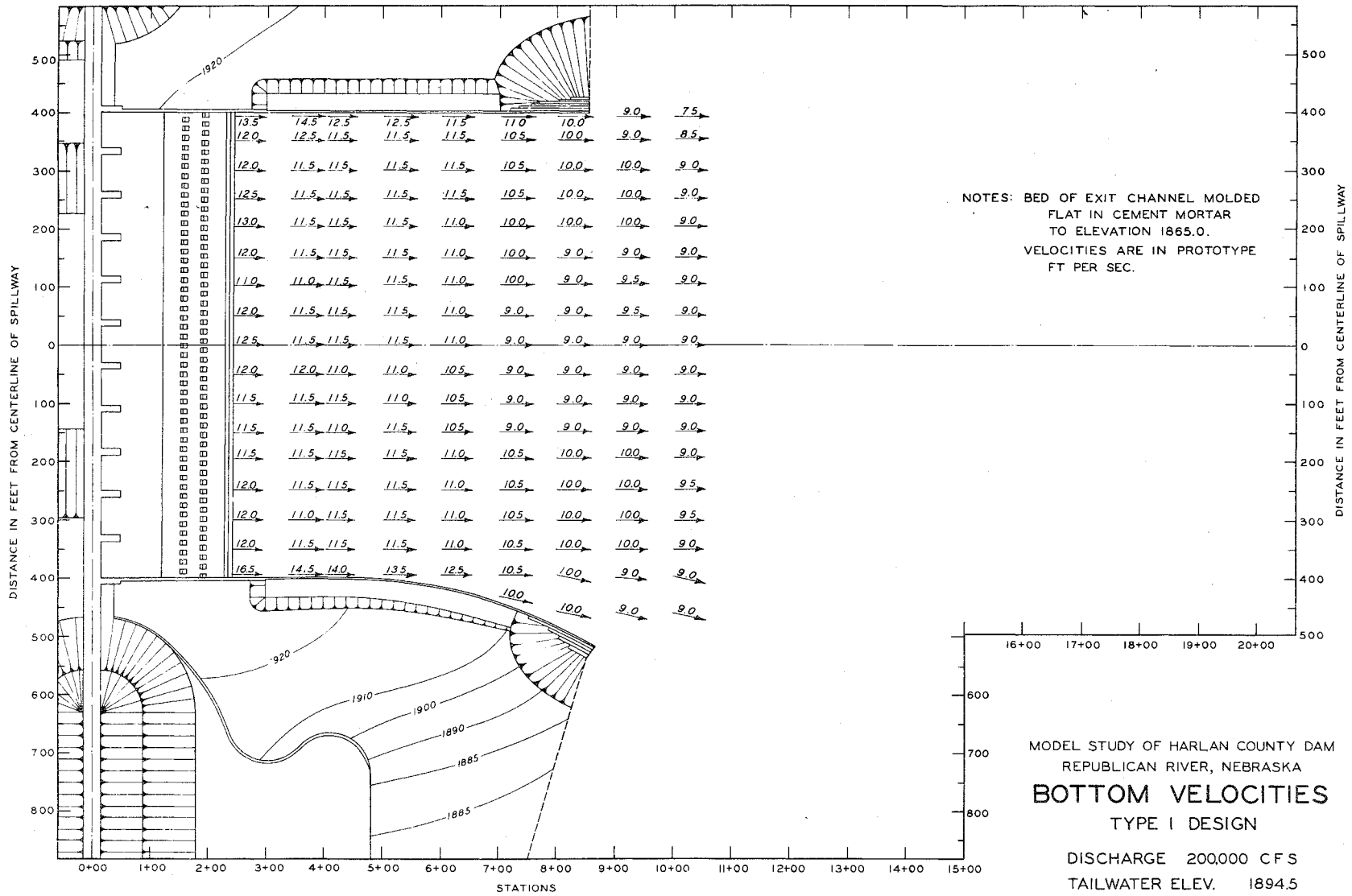

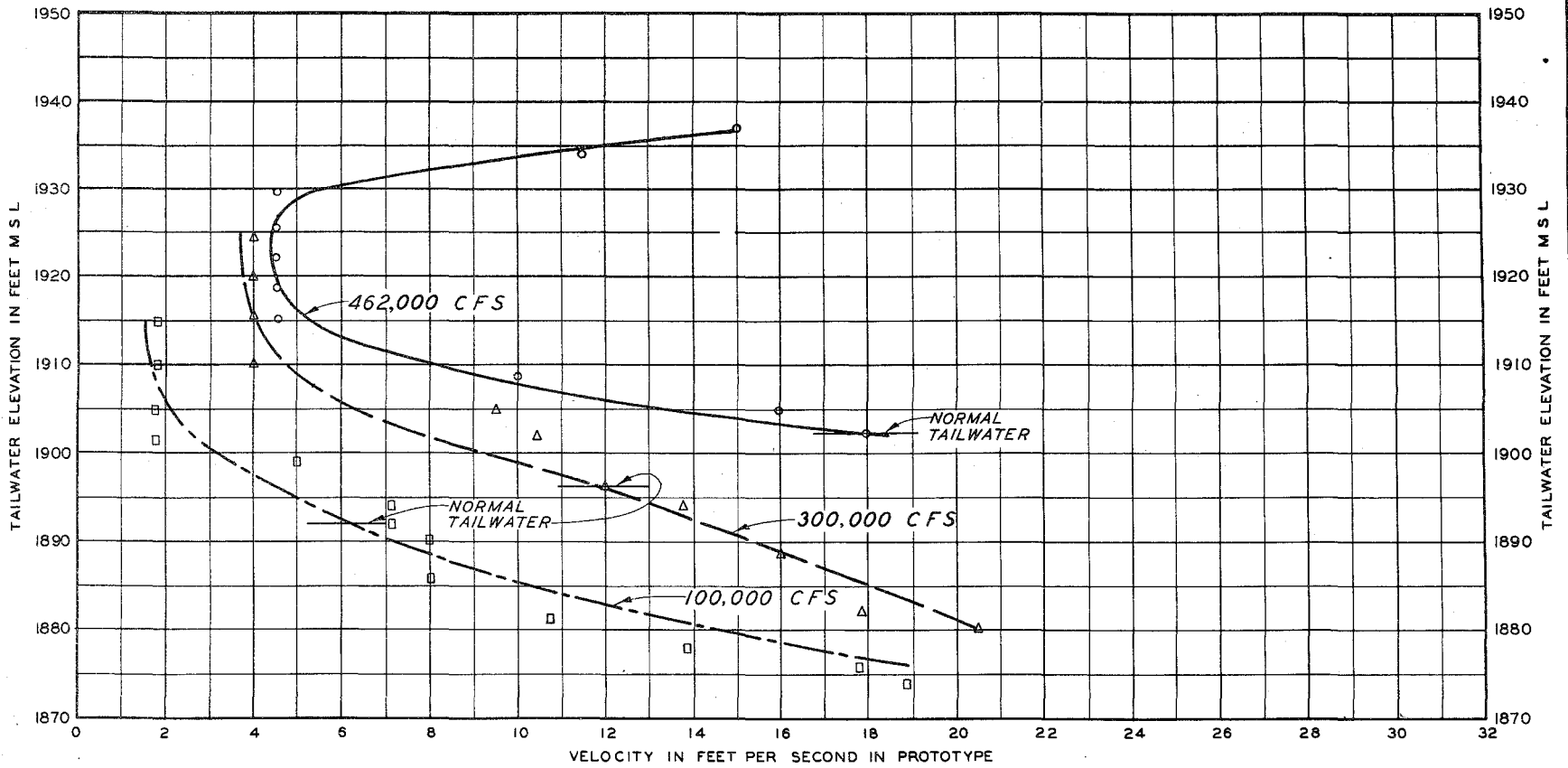

NOTES: VELOCITIES MEASURED 1.0 FT ABOVE END SILL, STA. 2+47.5
 END SILL AT ELEVATION 1865.0
 ALL BASIN ELEMENTS REMAINED ON APRON.

MODEL STUDY OF HARLAN COUNTY DAM
 REPUBLICAN RIVER, NEBRASKA
VELOCITY-TAILWATER CURVES
 TYPE I DESIGN

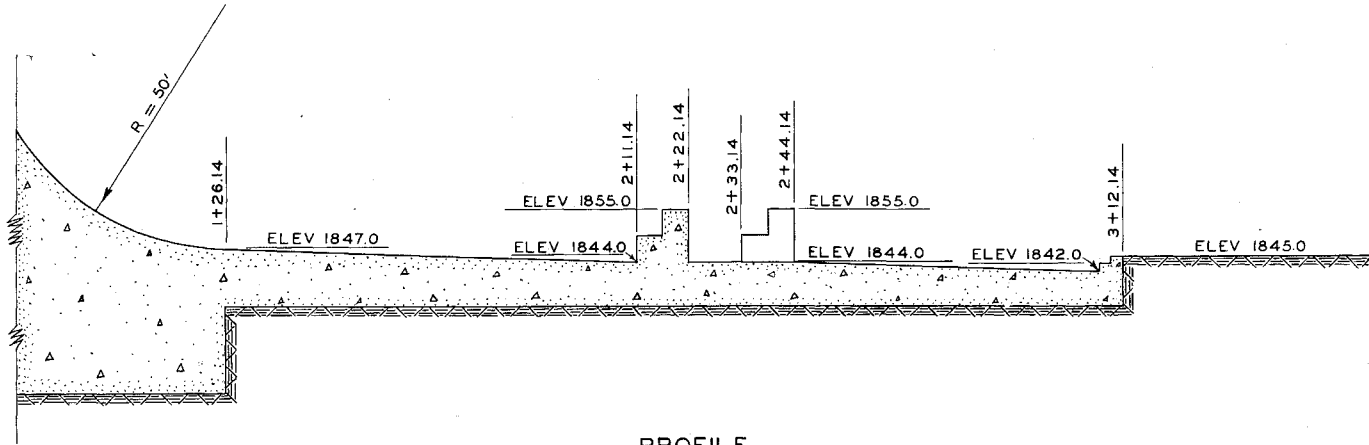

PROFILE

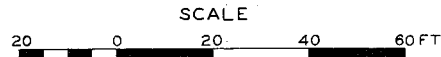

NOTE: ELEVATIONS ARE IN FEET REFERRED TO MSL.

MODEL STUDY OF HARLAN COUNTY DAM
REPUBLICAN RIVER, NEBRASKA

**TYPE 2 DESIGN
STILLING BASIN**

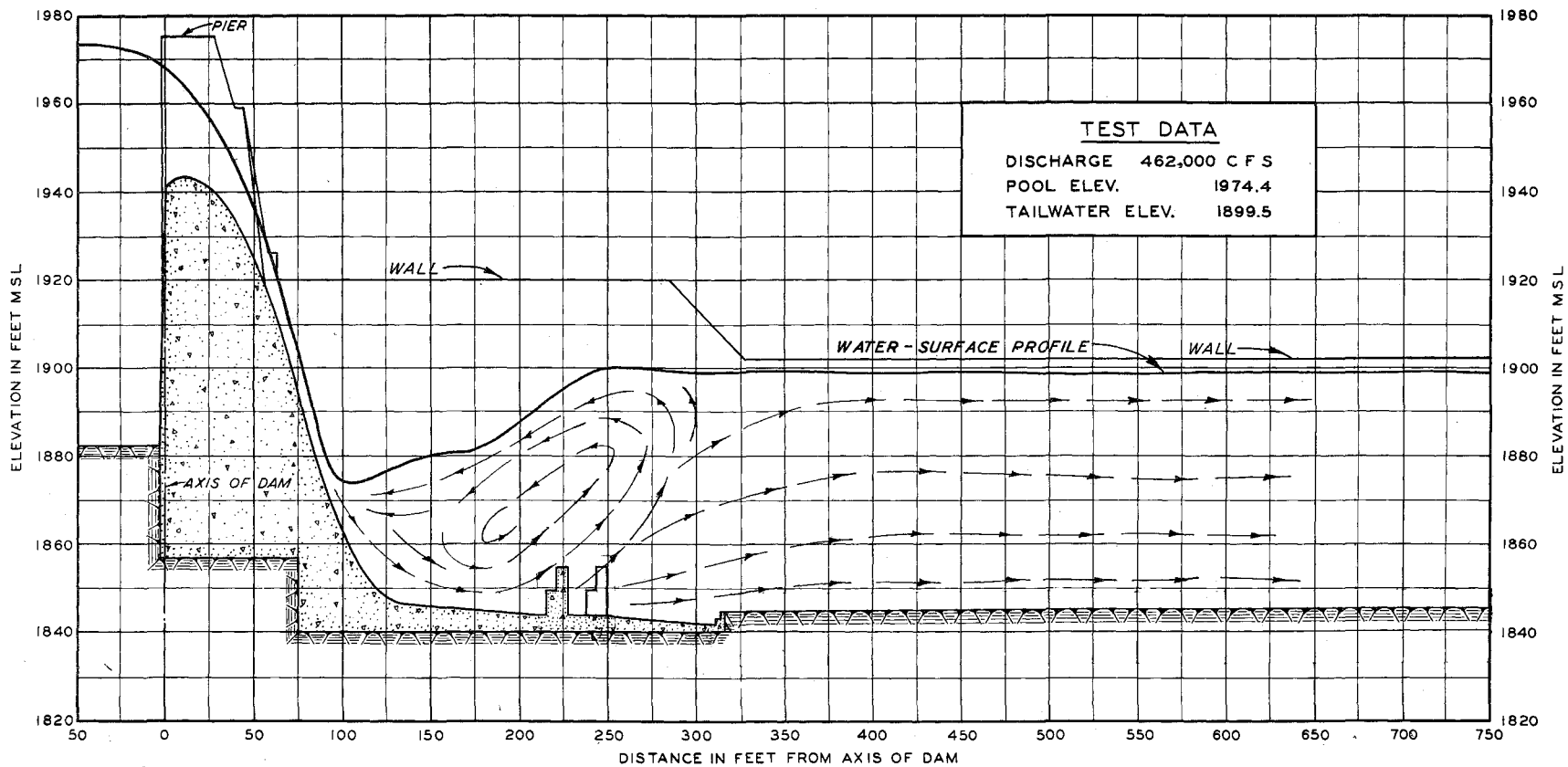

NOTE: WATER-SURFACE PROFILES MEASURED ALONG CENTERLINE OF SPILLWAY.

MODEL STUDY OF HARLAN COUNTY DAM
 REPUBLICAN RIVER, NEBRASKA
WATER-SURFACE PROFILE
 TYPE 2 DESIGN

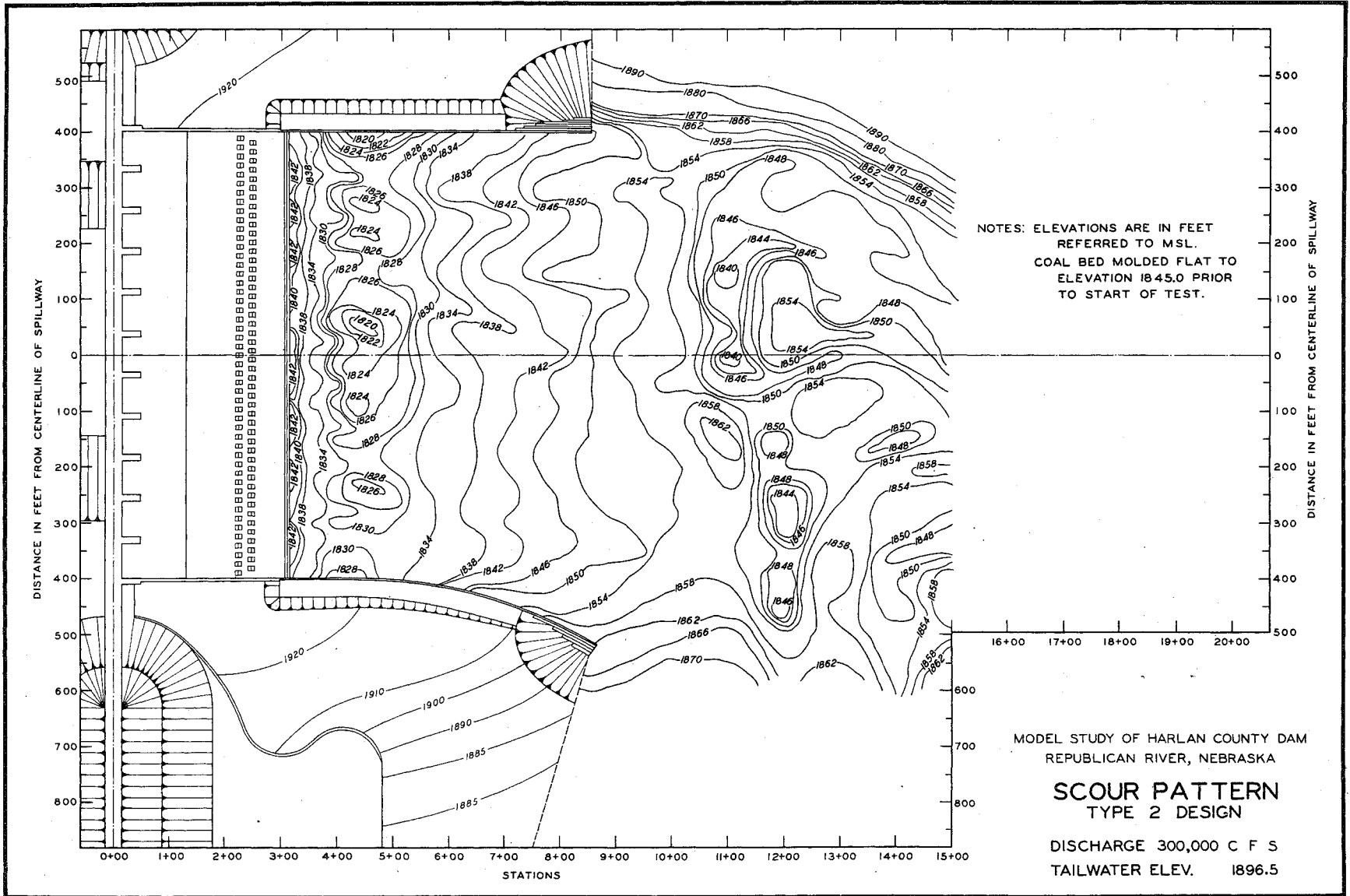

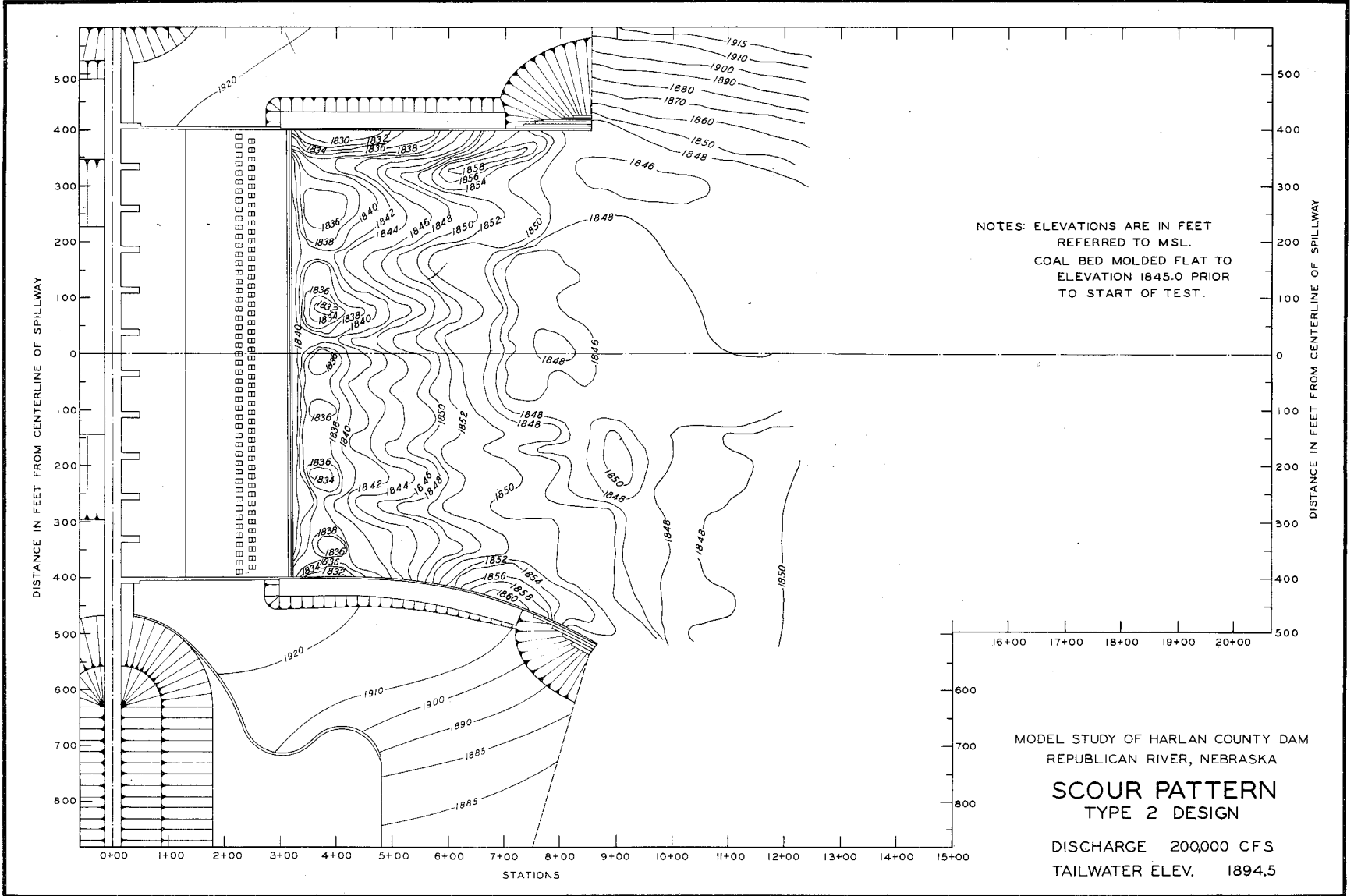

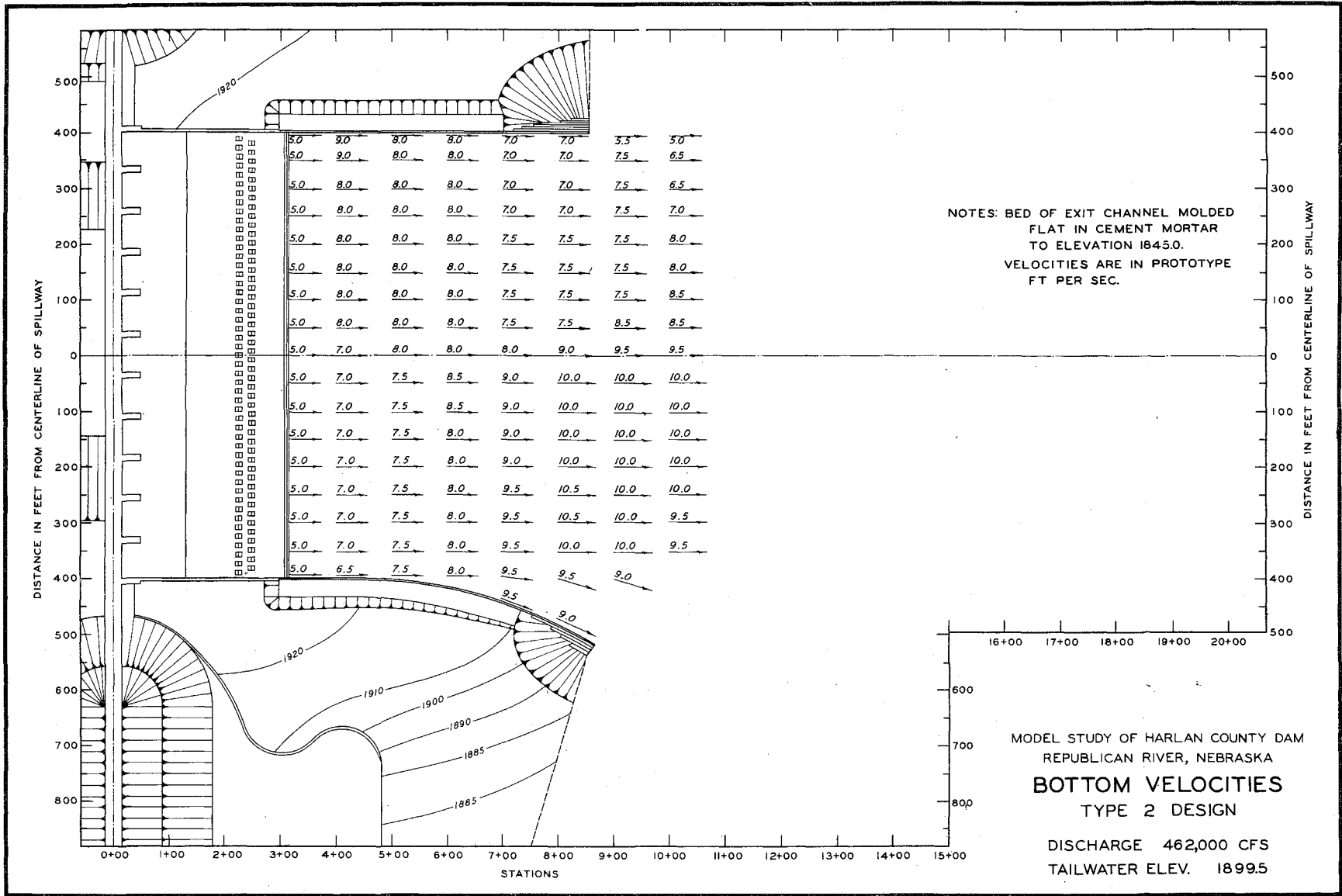

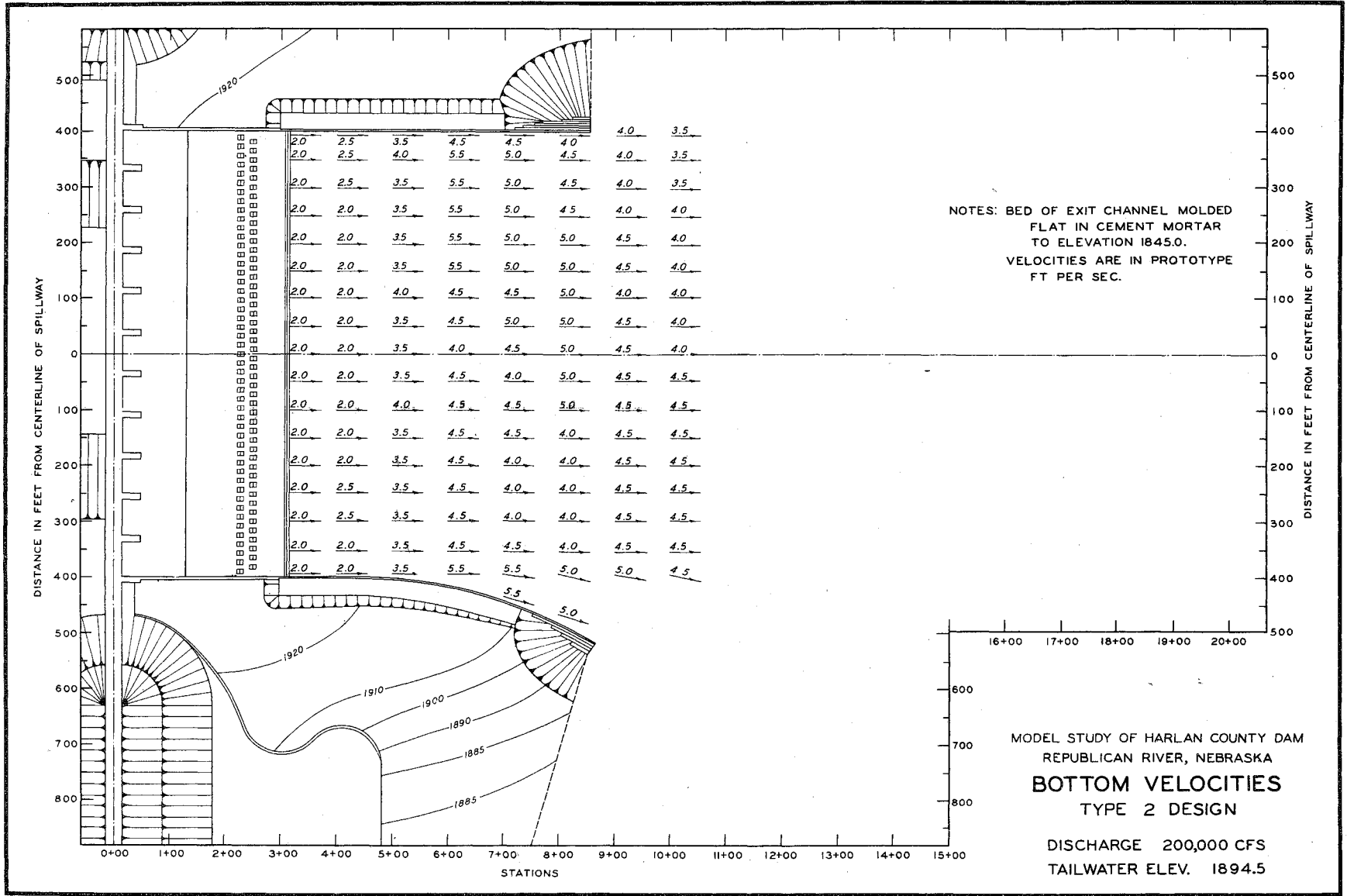

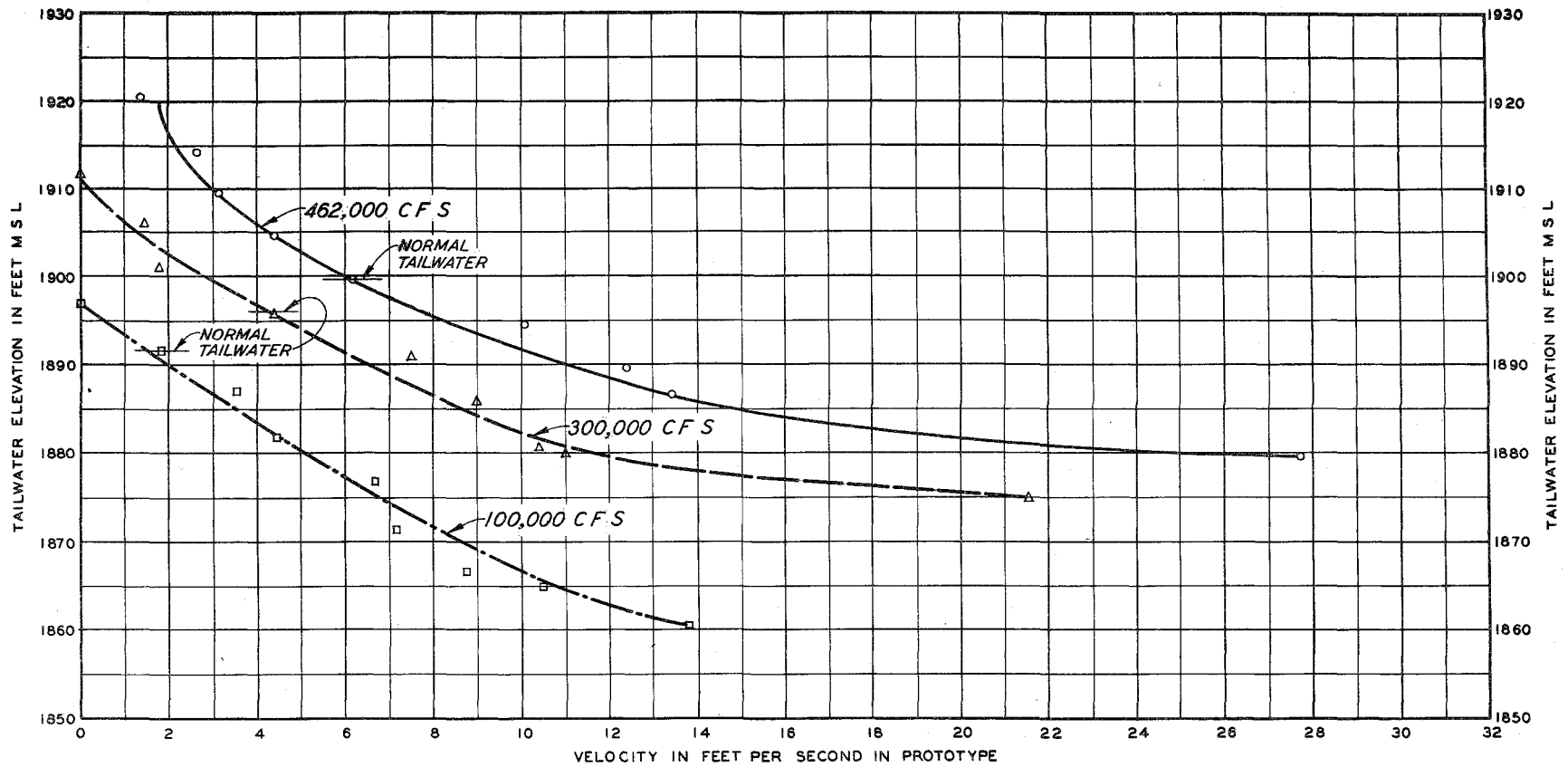

NOTES: VELOCITIES MEASURED 10 FT ABOVE END SILL, STA. 3+16.64
 END SILL AT ELEVATION 1845.0
 ALL BASIN ELEMENTS REMAINED ON APRON.

MODEL STUDY OF HARLAN COUNTY DAM
 REPUBLICAN RIVER, NEBRASKA
VELOCITY-TAILWATER CURVES
 TYPE 2 DESIGN

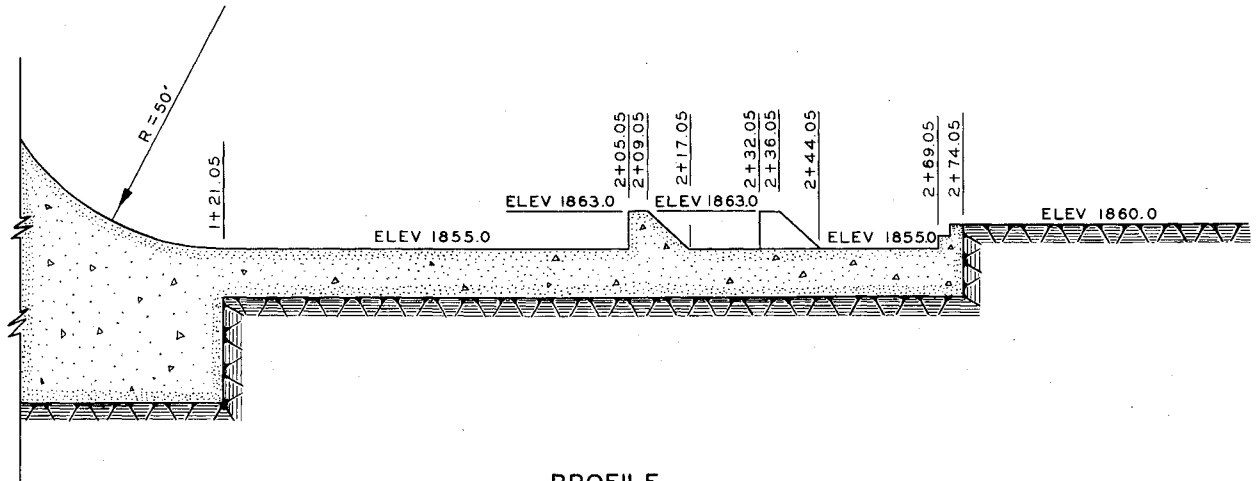

PROFILE

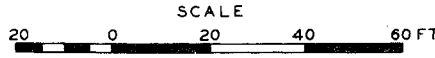

NOTE: ELEVATIONS ARE IN FEET REFERRED TO MSL.

MODEL STUDY OF HARLAN COUNTY DAM
 REPUBLICAN RIVER, NEBRASKA
TYPE 3 DESIGN
STILLING BASIN

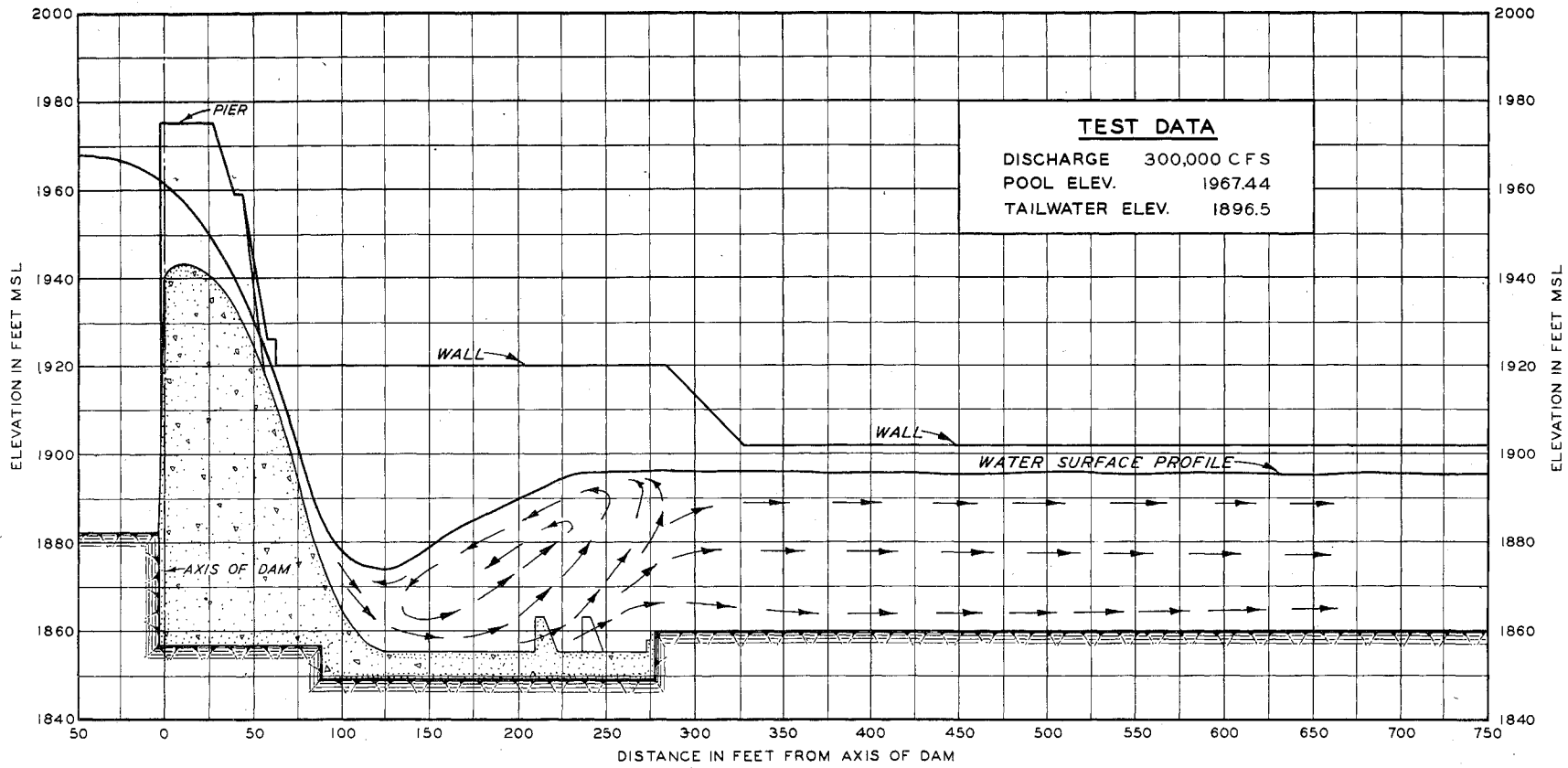

NOTE: WATER-SURFACE PROFILES MEASURED ALONG CENTERLINE OF SPILLWAY.

MODEL STUDY OF HARLAN COUNTY DAM
 REPUBLICAN RIVER, NEBRASKA
WATER-SURFACE PROFILE
 TYPE 3 DESIGN

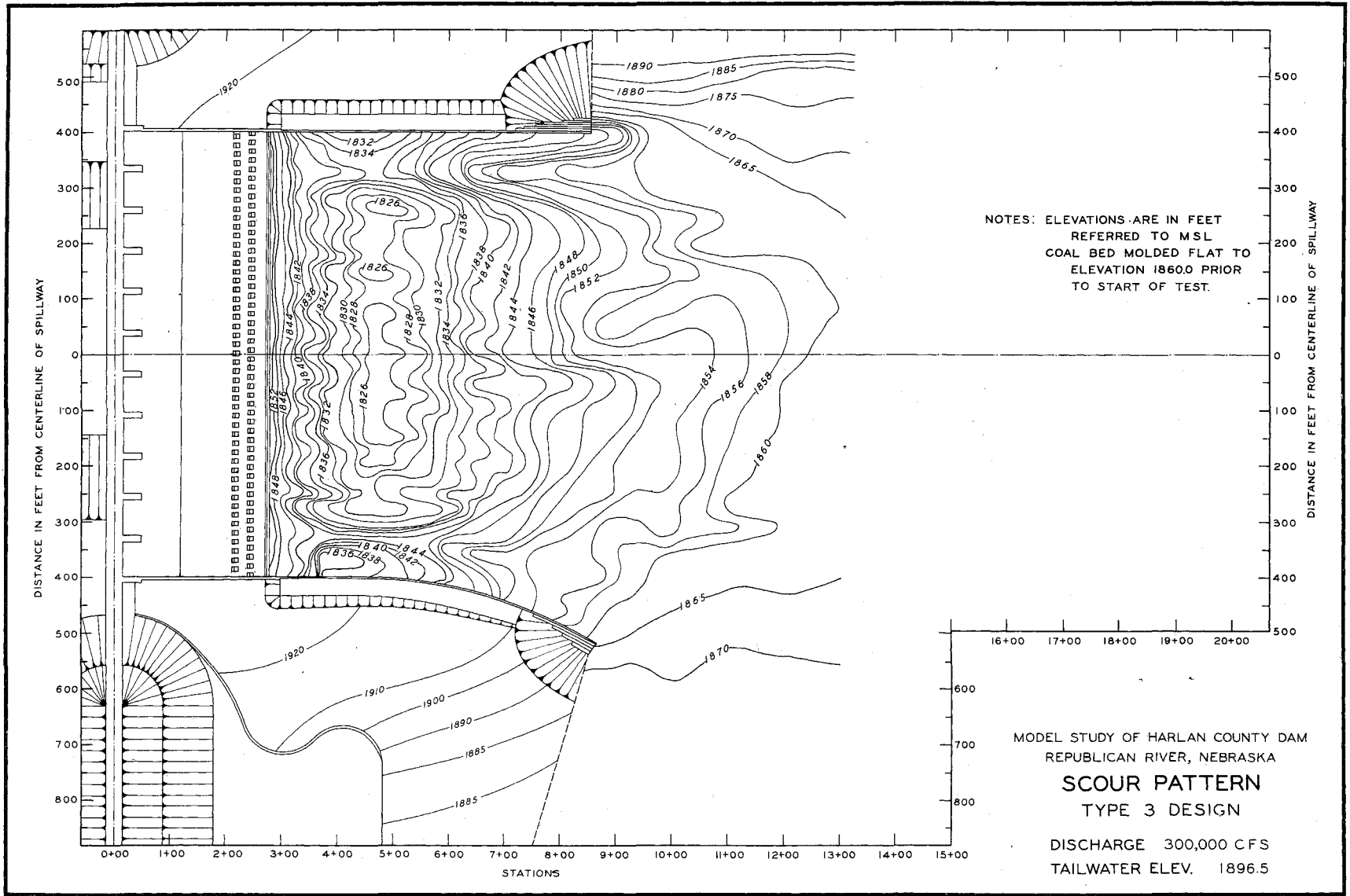

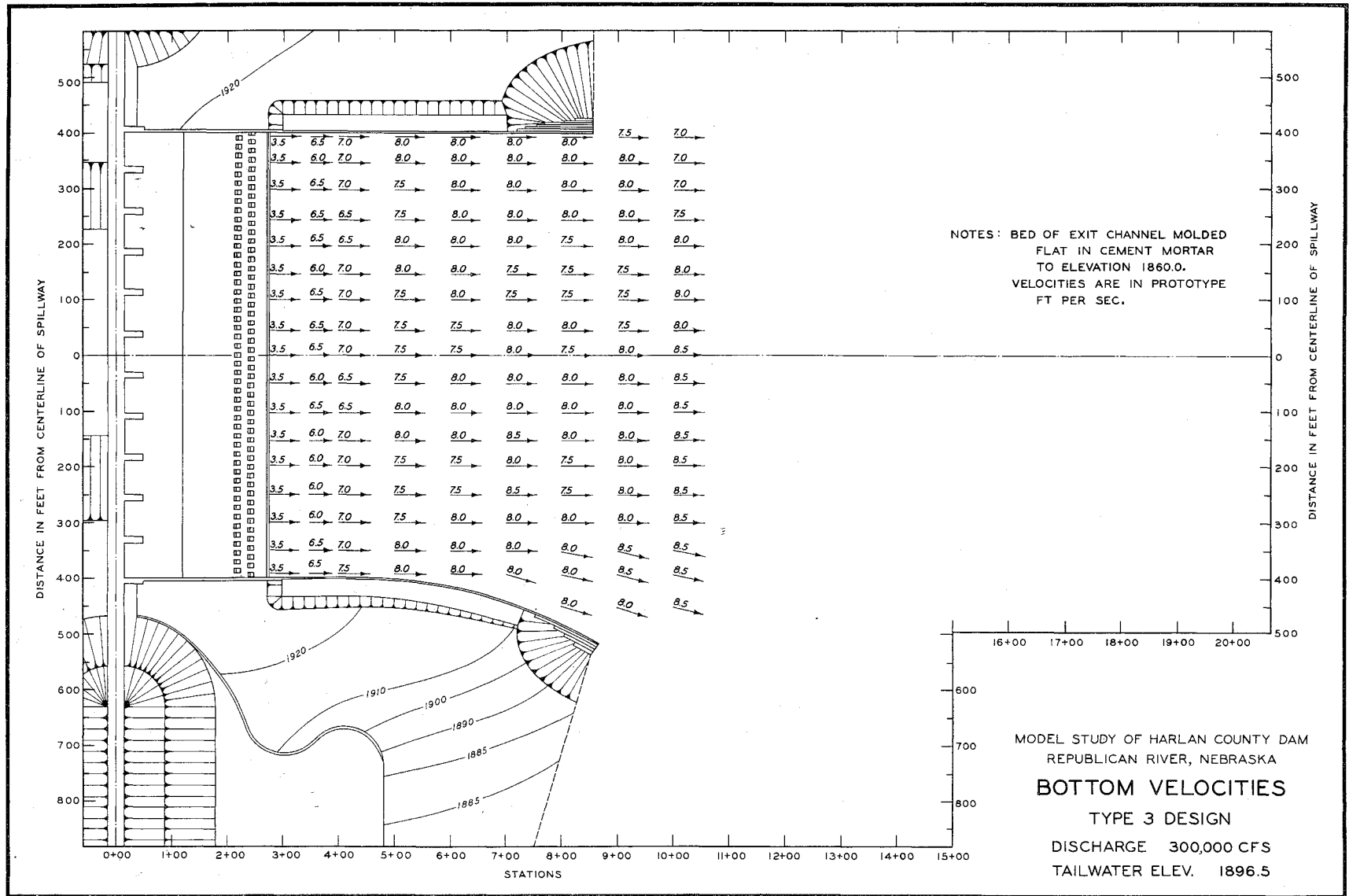

NOTES: BED OF EXIT CHANNEL MOLDED
 FLAT IN CEMENT MORTAR
 TO ELEVATION 1860.0.
 VELOCITIES ARE IN PROTOTYPE
 FT PER SEC.

16+00 17+00 18+00 19+00 20+00

MODEL STUDY OF HARLAN COUNTY DAM
 REPUBLICAN RIVER, NEBRASKA
BOTTOM VELOCITIES
 TYPE 3 DESIGN
 DISCHARGE 300,000 CFS
 TAILWATER ELEV. 1896.5

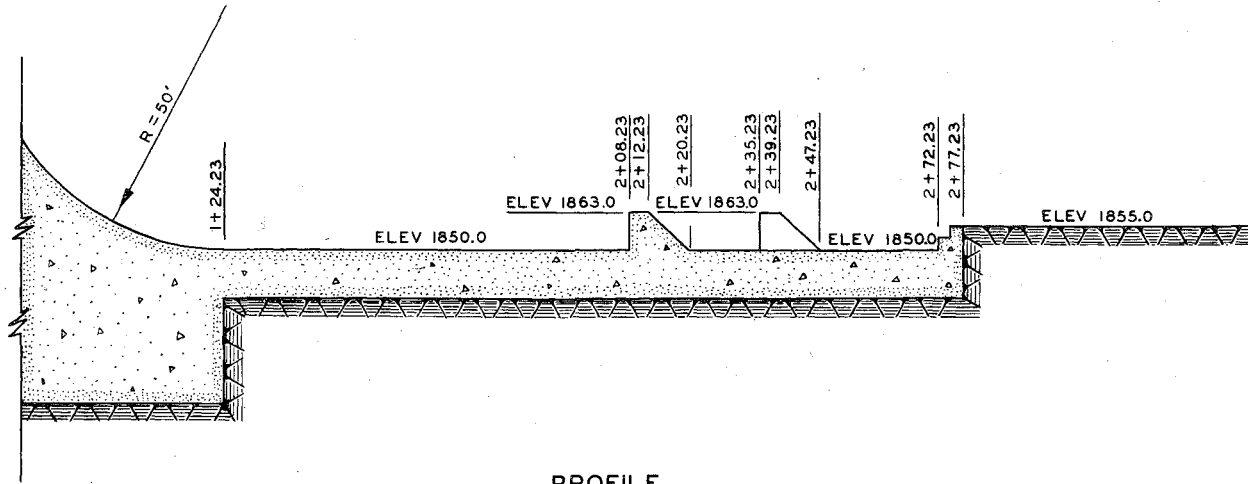

PROFILE

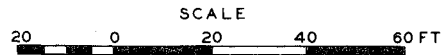

NOTE: ELEVATIONS ARE IN FEET REFERRED TO MSL.

MODEL STUDY OF HARLAN COUNTY DAM
REPUBLICAN RIVER, NEBRASKA

**TYPE 4 DESIGN
STILLING BASIN**

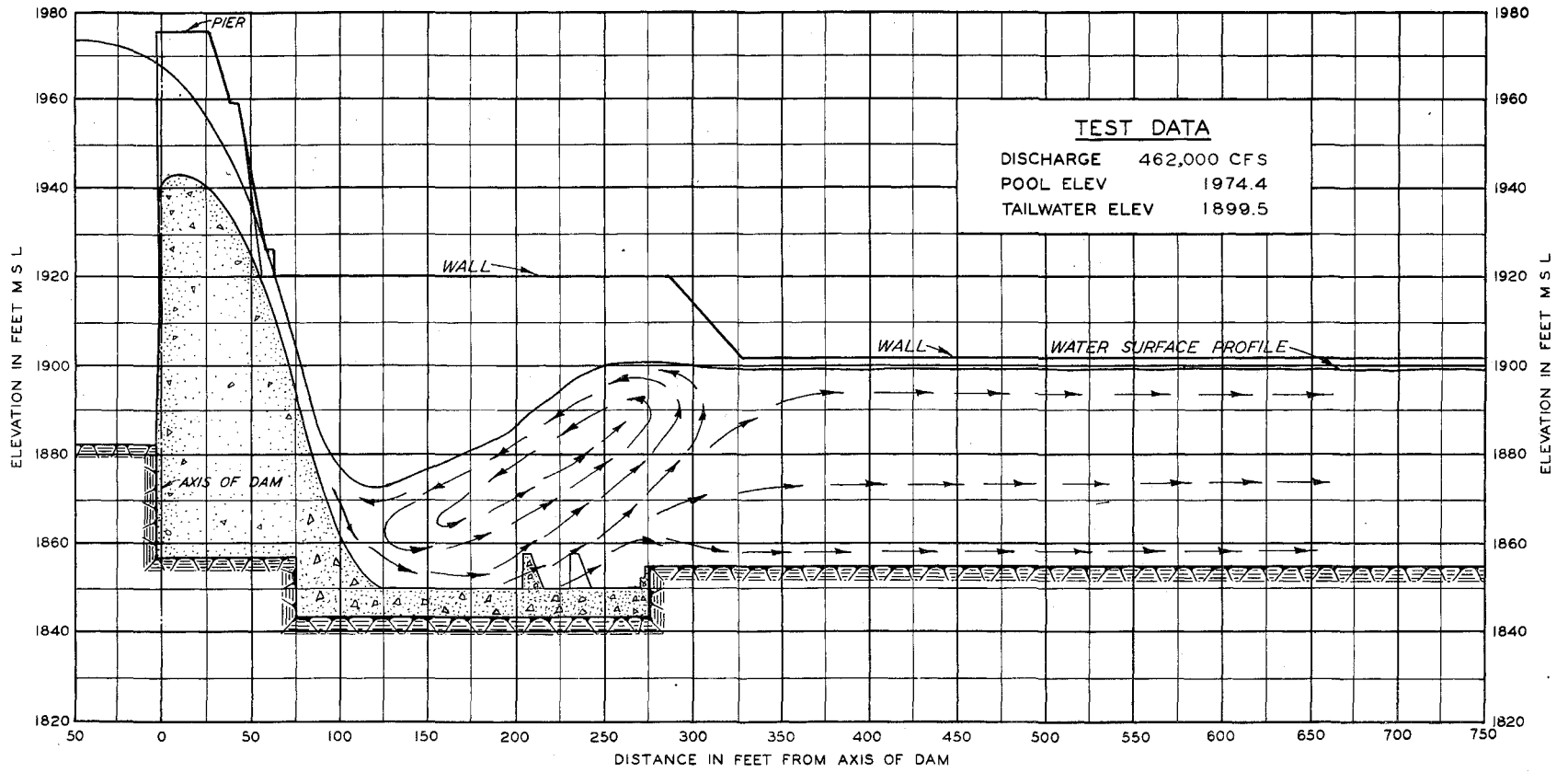

NOTE: WATER-SURFACE PROFILES MEASURED ALONG CENTERLINE OF SPILLWAY.

MODEL STUDY OF HARLAN COUNTY DAM
 REPUBLICAN RIVER, NEBRASKA.
WATER-SURFACE PROFILE
 TYPE 4 DESIGN

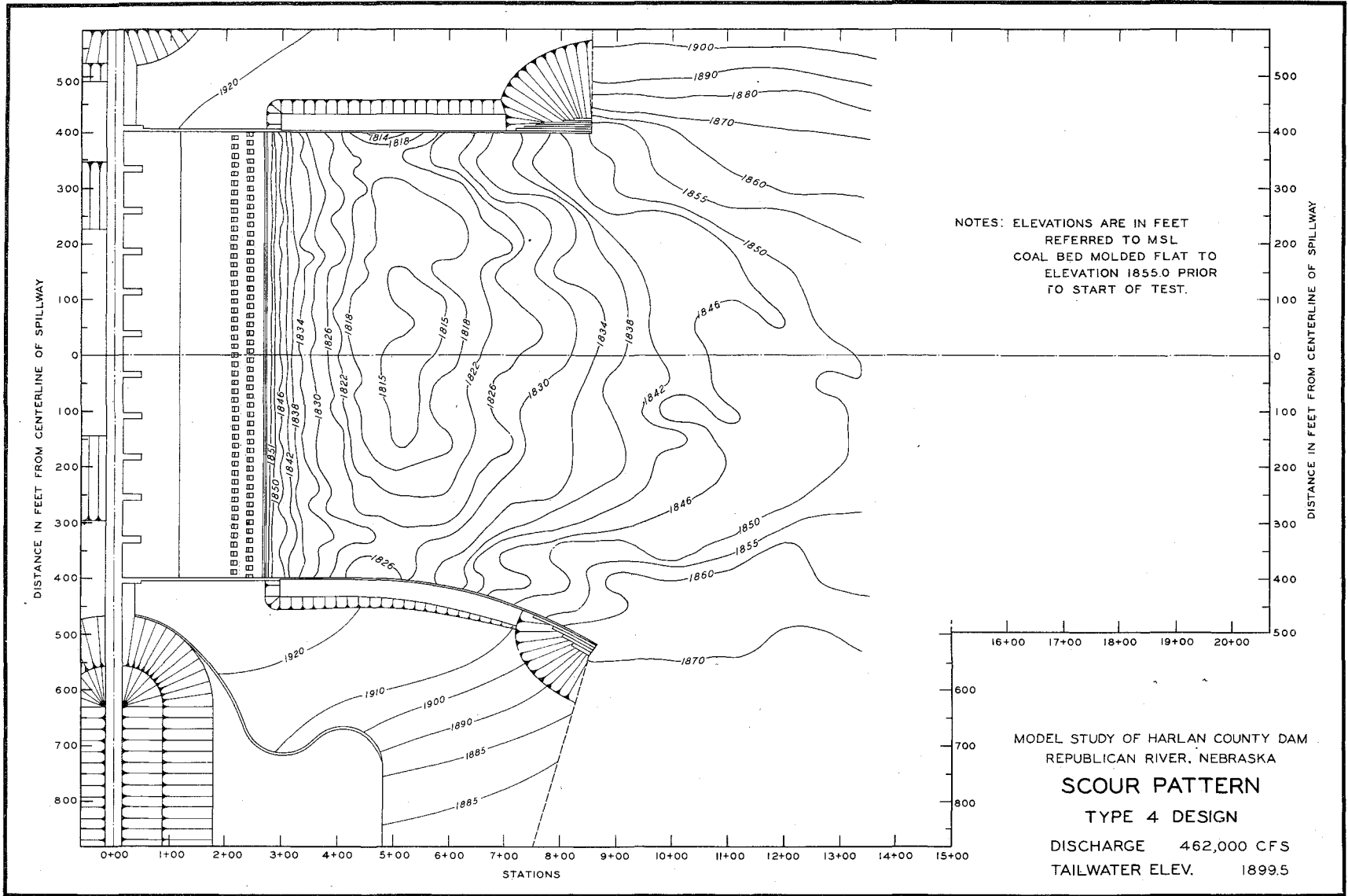

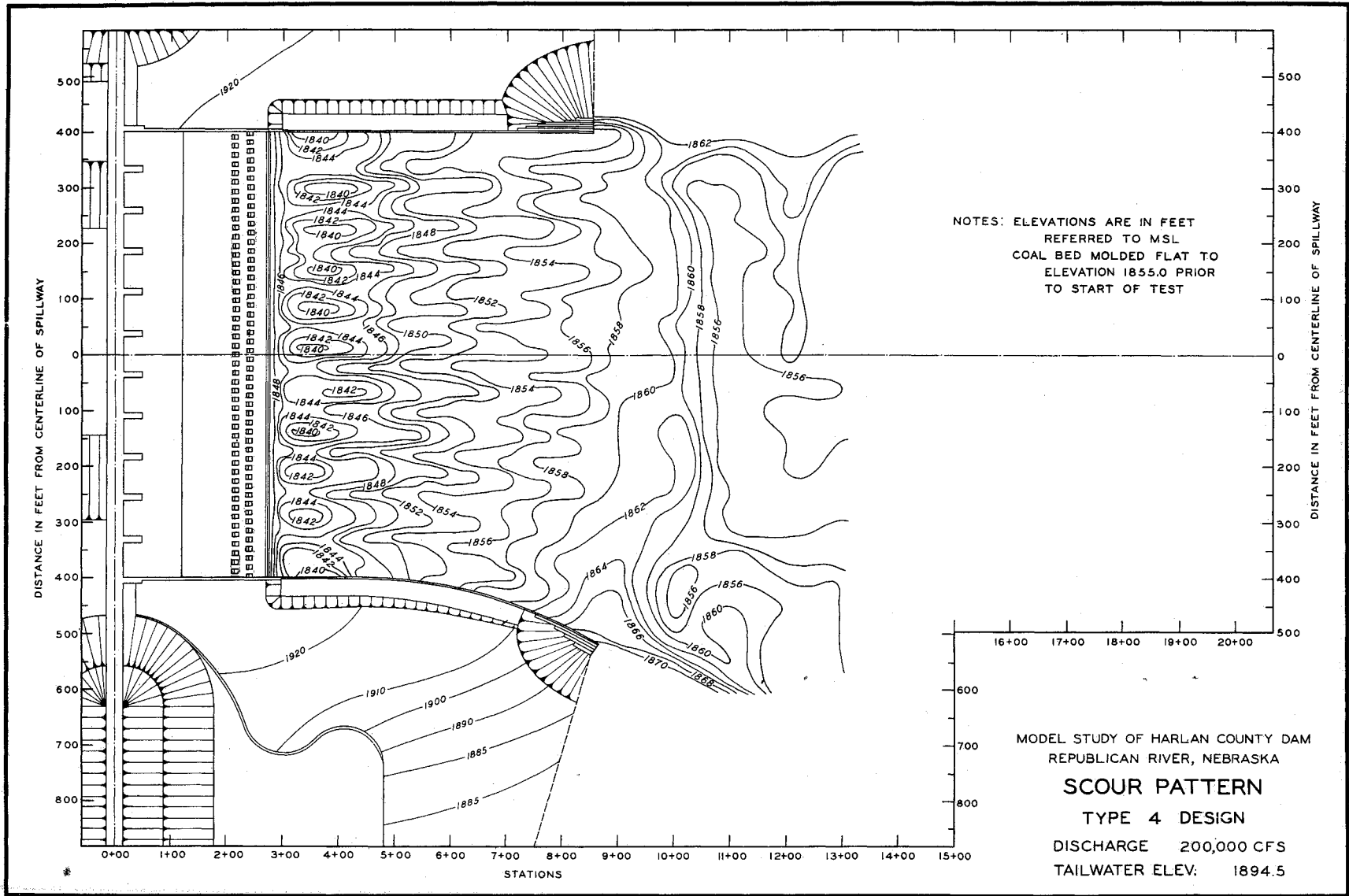

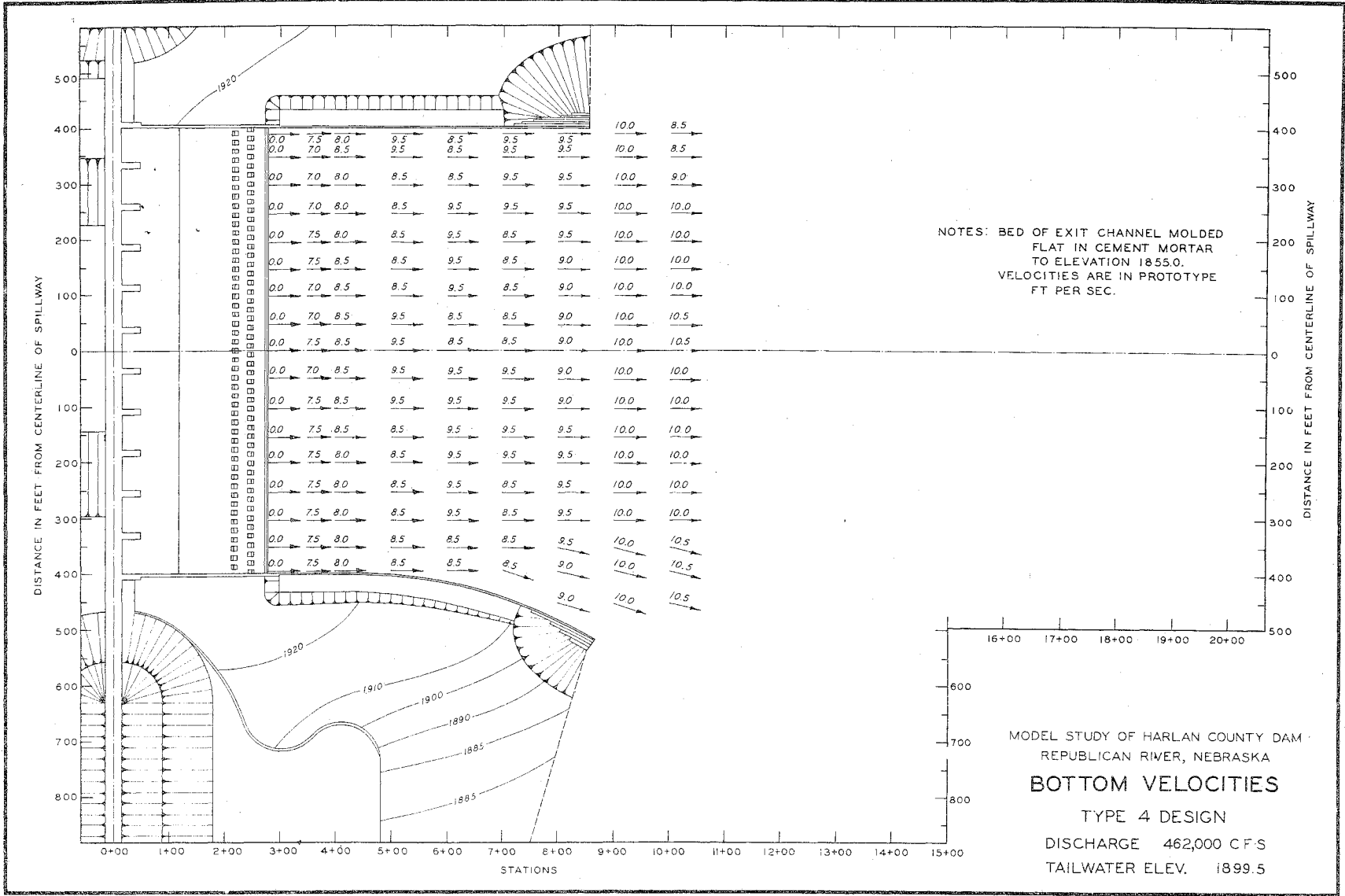

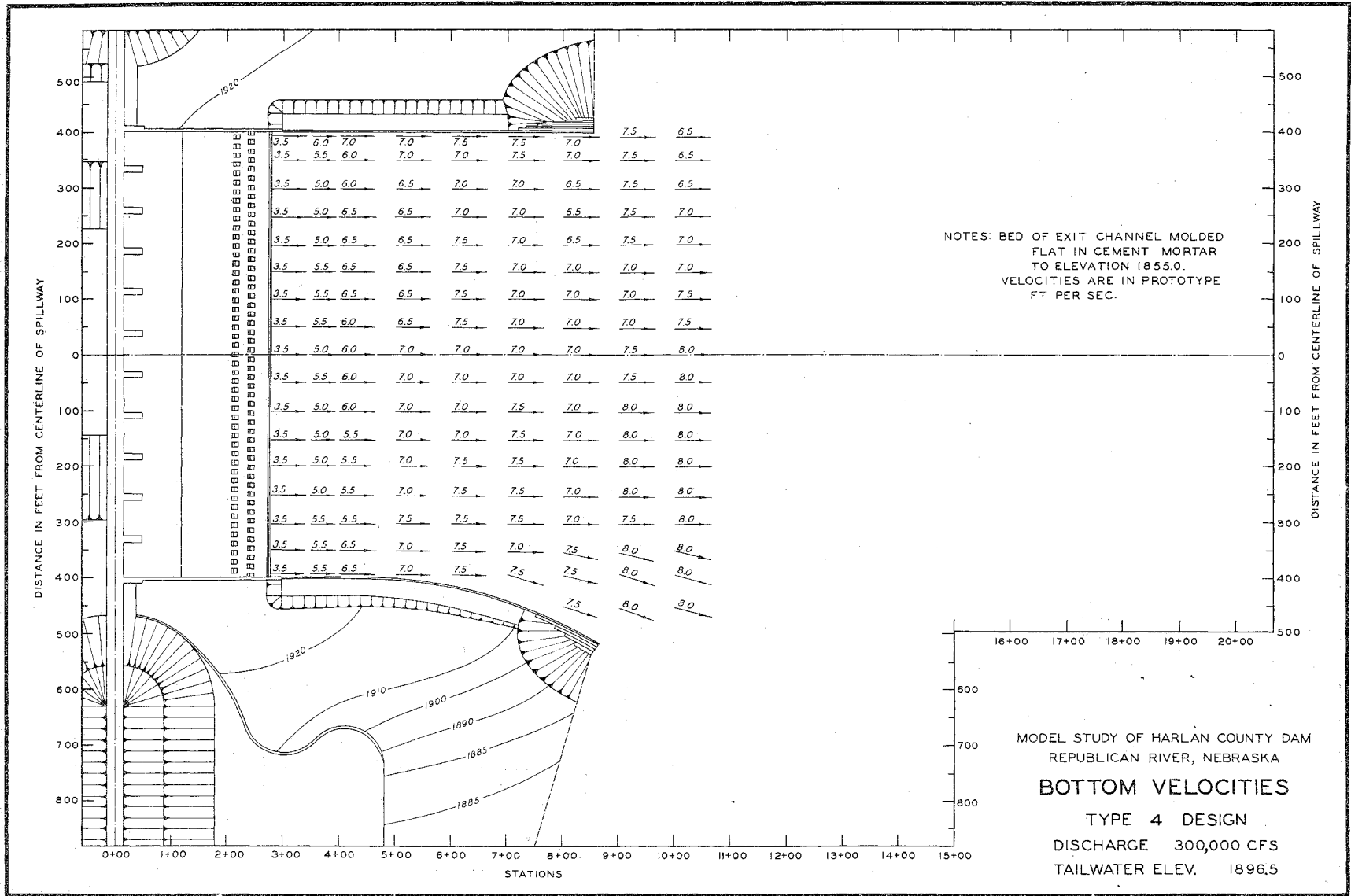

MODEL STUDY OF HARLAN COUNTY DAM
 REPUBLICAN RIVER, NEBRASKA
BOTTOM VELOCITIES
 TYPE 4 DESIGN
 DISCHARGE 300,000 CFS
 TAILWATER ELEV. 1896.5

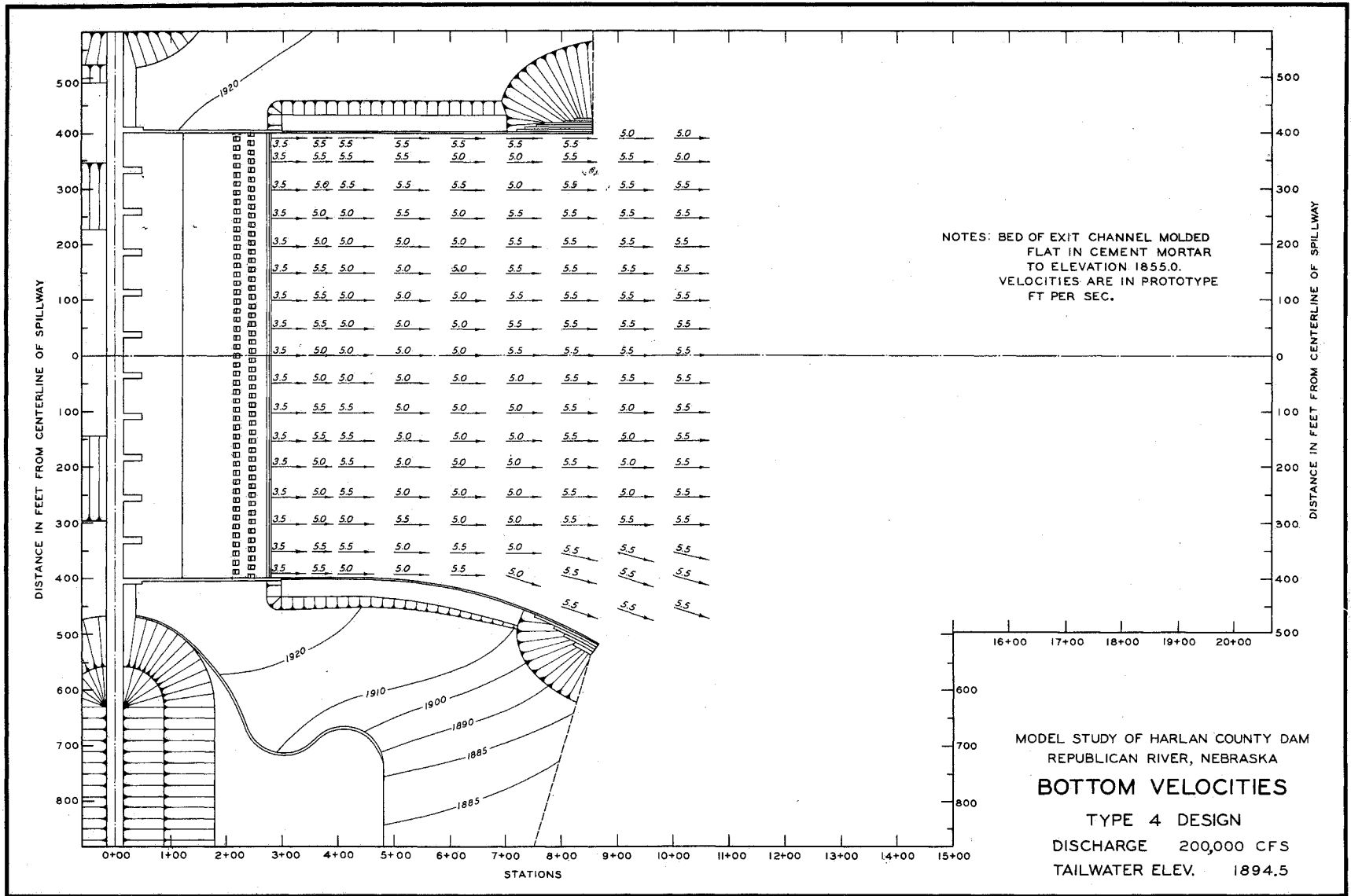

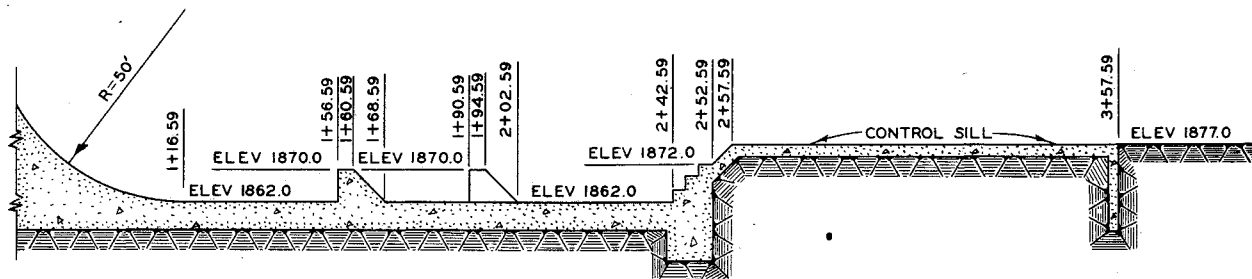

PROFILE

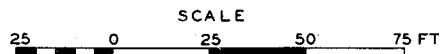

NOTE: ELEVATIONS ARE IN FEET REFERRED TO MSL.

MODEL STUDY OF HARLAN COUNTY DAM
REPUBLICAN RIVER, NEBRASKA

**TYPE 5 DESIGN
STILLING BASIN**

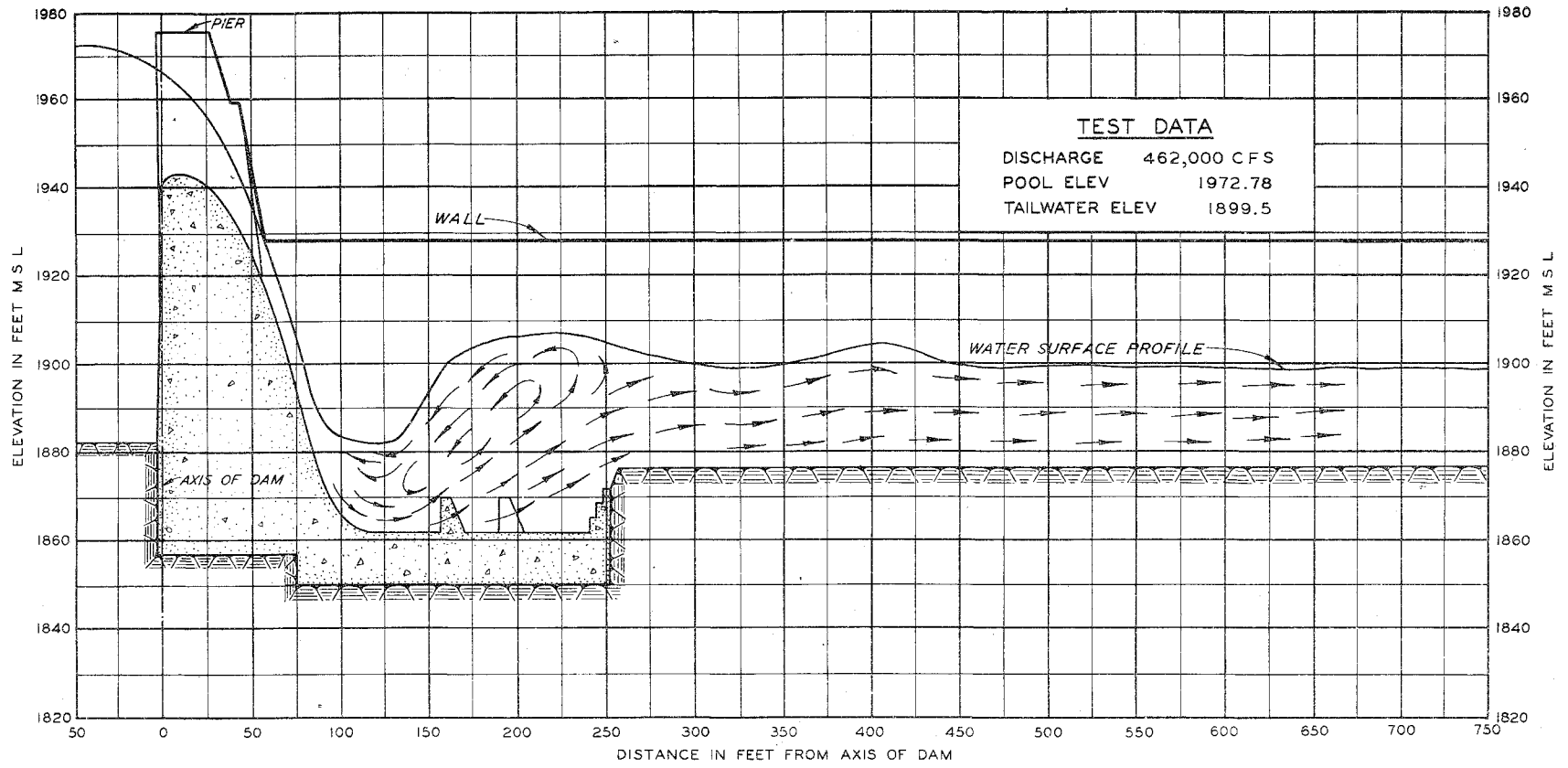

NOTE: WATER-SURFACE PROFILES MEASURED ALONG CENTERLINE OF SPILLWAY.

MODEL STUDY OF HARLAN COUNTY DAM
REPUBLICAN RIVER, NEBRASKA.

WATER-SURFACE PROFILE
TYPE 5 DESIGN

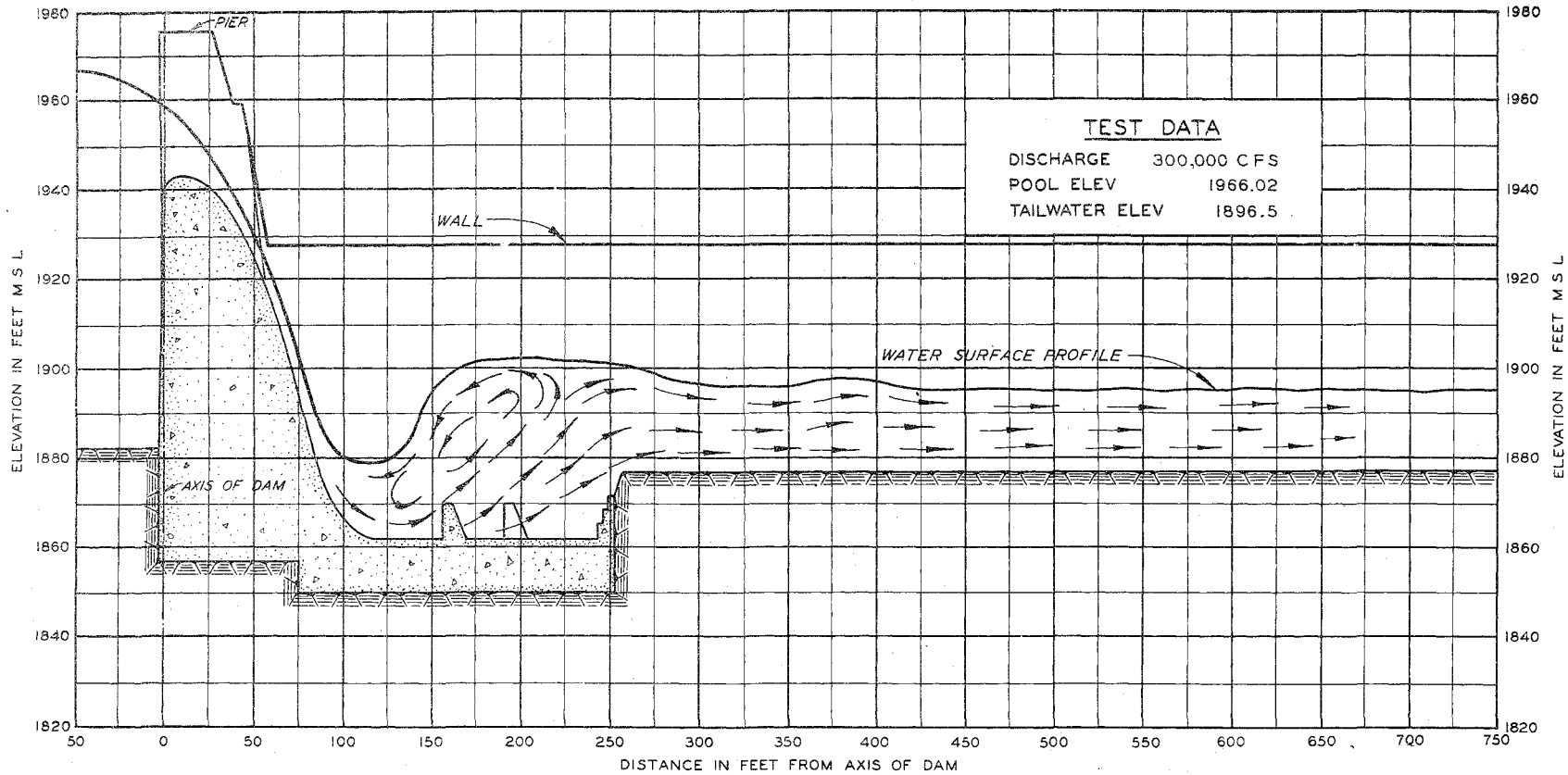

NOTE: WATER-SURFACE PROFILES MEASURED ALONG CENTERLINE OF SPILLWAY.

MODEL STUDY OF HARLAN COUNTY DAM
 REPUBLICAN RIVER, NEBRASKA.
WATER-SURFACE PROFILE
 TYPE 5 DESIGN

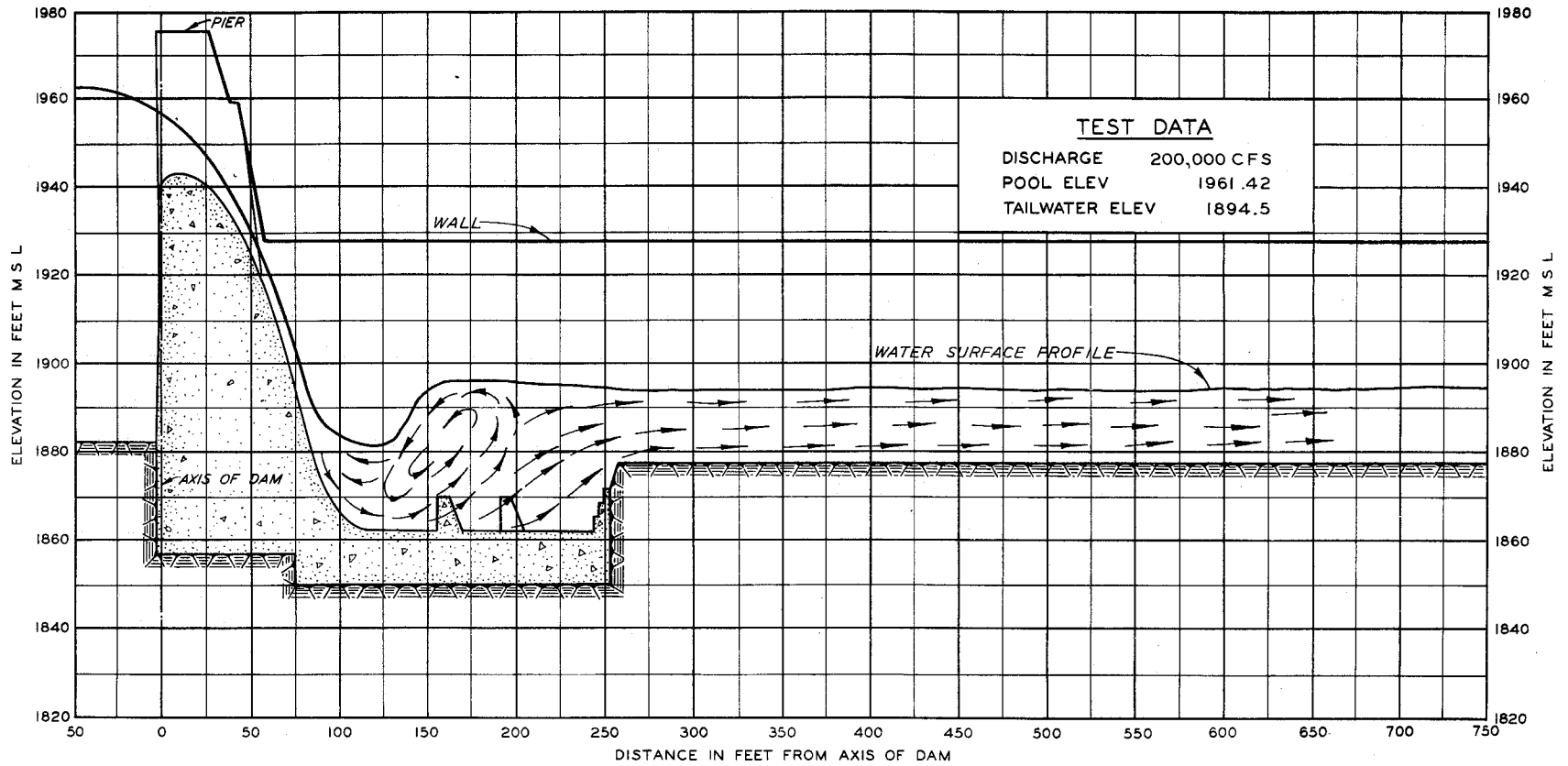

NOTE: WATER-SURFACE PROFILES MEASURED ALONG CENTERLINE OF SPILLWAY.

MODEL STUDY OF HARLAN COUNTY DAM
 REPUBLICAN RIVER, NEBRASKA.
WATER-SURFACE PROFILE
 TYPE 5 DESIGN

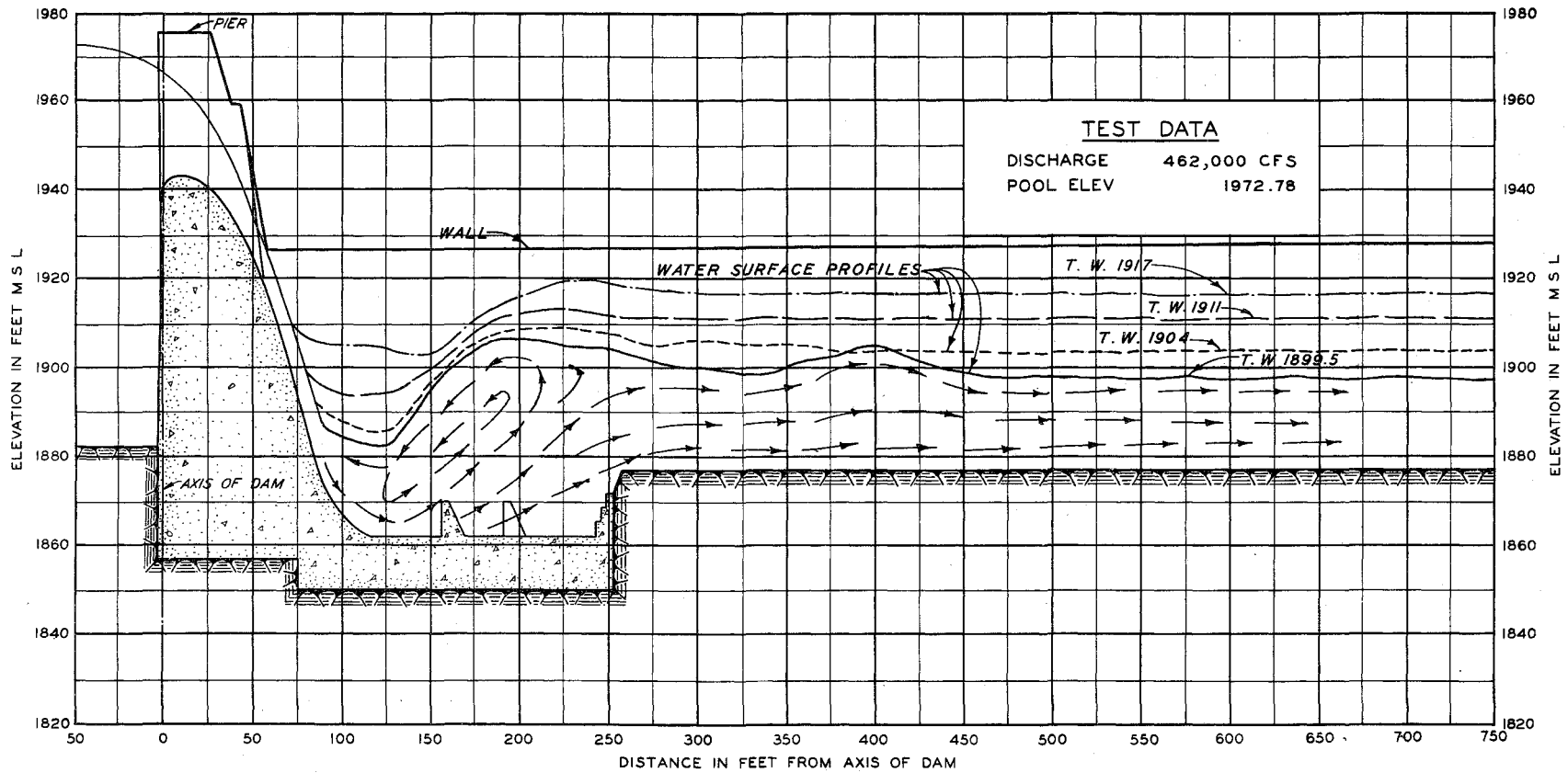

NOTE: WATER-SURFACE PROFILES MEASURED ALONG CENTERLINE OF SPILLWAY.

MODEL STUDY OF HARLAN COUNTY DAM
REPUBLICAN RIVER, NEBRASKA.
WATER-SURFACE PROFILES
TYPE 5 DESIGN

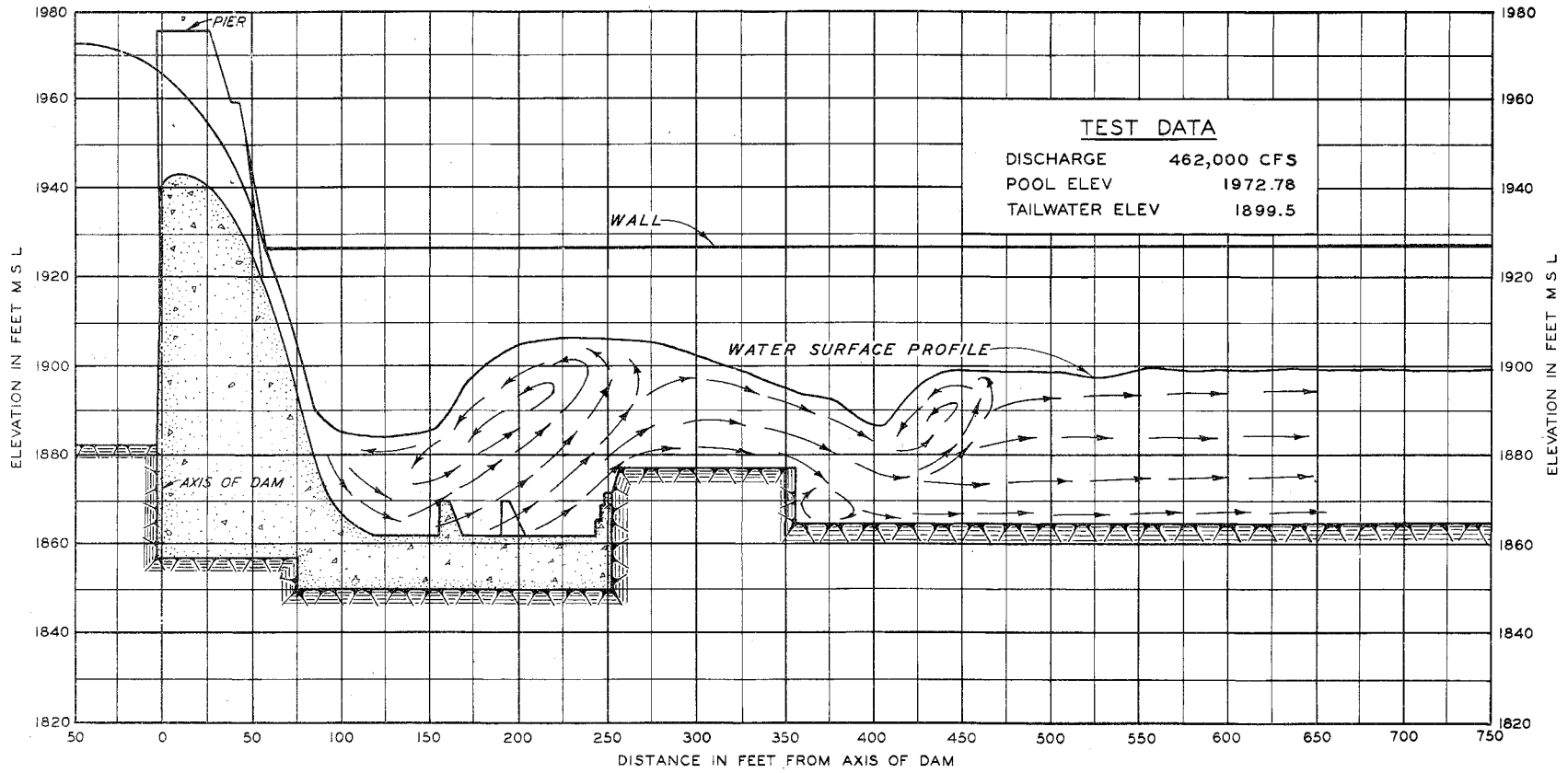

NOTE: WATER-SURFACE PROFILES MEASURED ALONG CENTERLINE OF SPILLWAY.

MODEL STUDY OF HARLAN COUNTY DAM
 REPUBLICAN RIVER, NEBRASKA.
WATER-SURFACE PROFILE
 TYPE 5 DESIGN

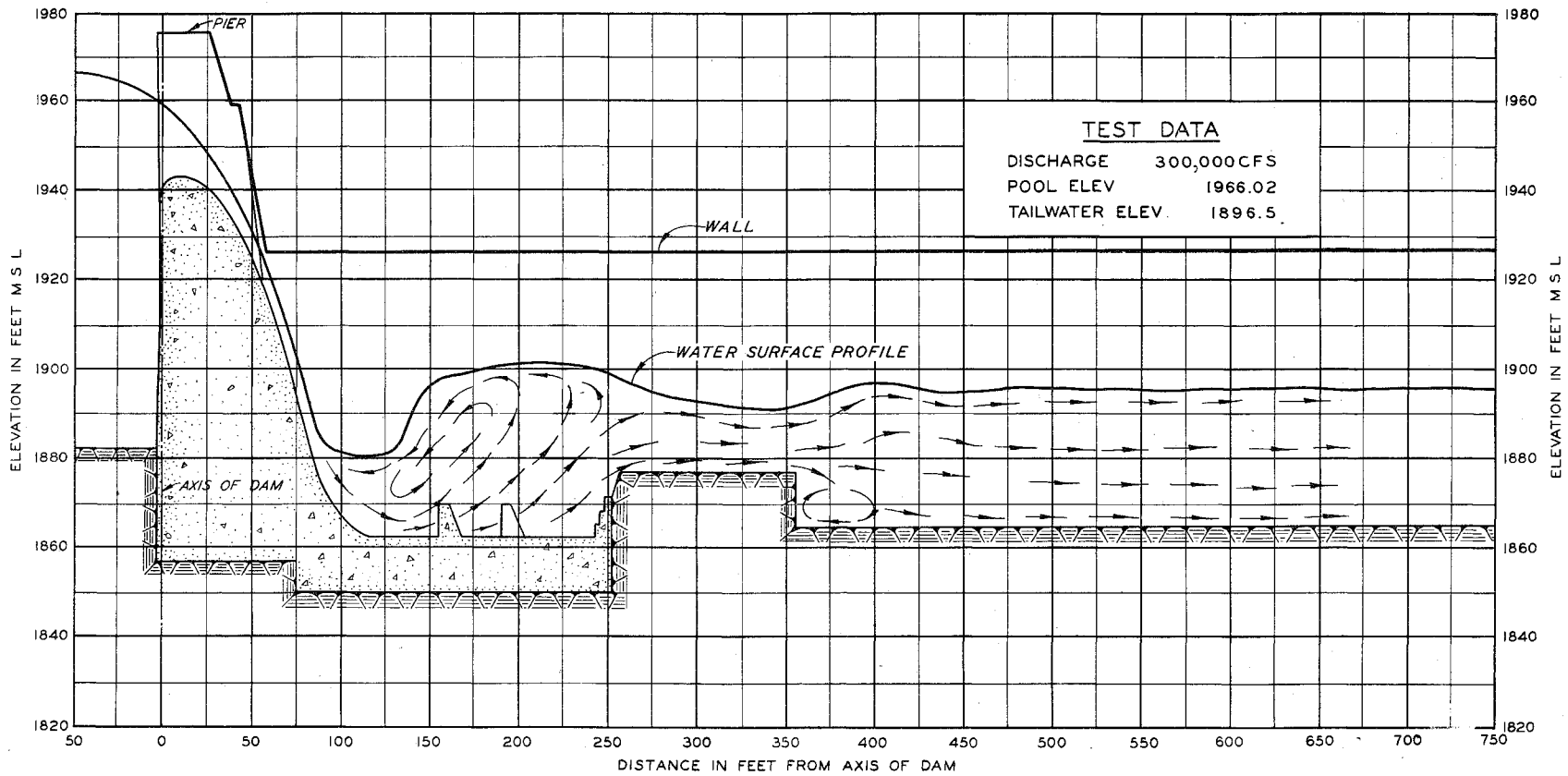

NOTE: WATER-SURFACE PROFILES MEASURED ALONG CENTERLINE OF SPILLWAY.

MODEL STUDY OF HARLAN COUNTY DAM
 REPUBLICAN RIVER, NEBRASKA.
WATER-SURFACE PROFILE
 TYPE 5 DESIGN

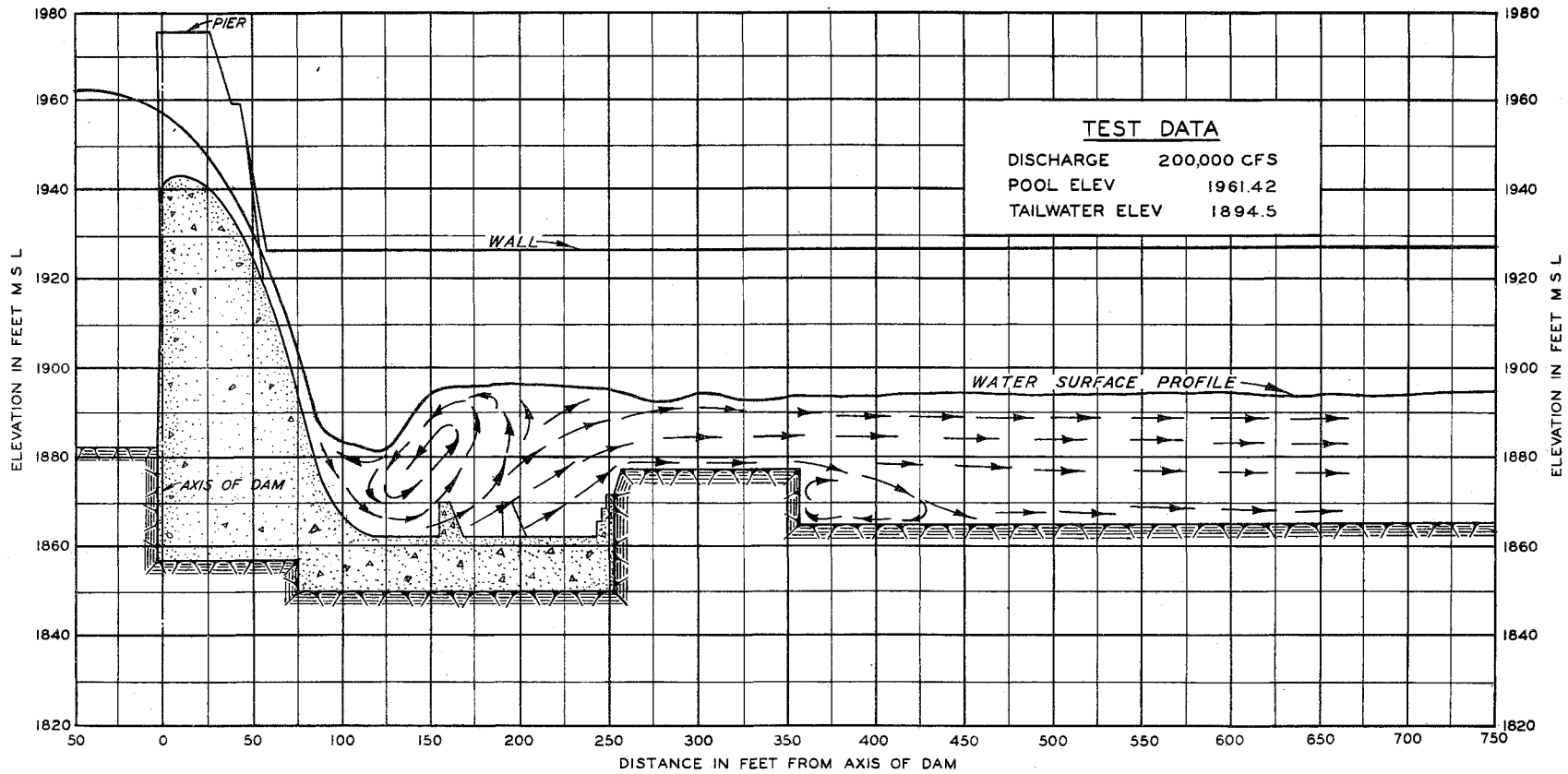

NOTE: WATER-SURFACE PROFILES MEASURED ALONG CENTERLINE OF SPILLWAY.

MODEL STUDY OF HARLAN COUNTY DAM
 REPUBLICAN RIVER, NEBRASKA.
WATER-SURFACE PROFILE
 TYPE 5 DESIGN

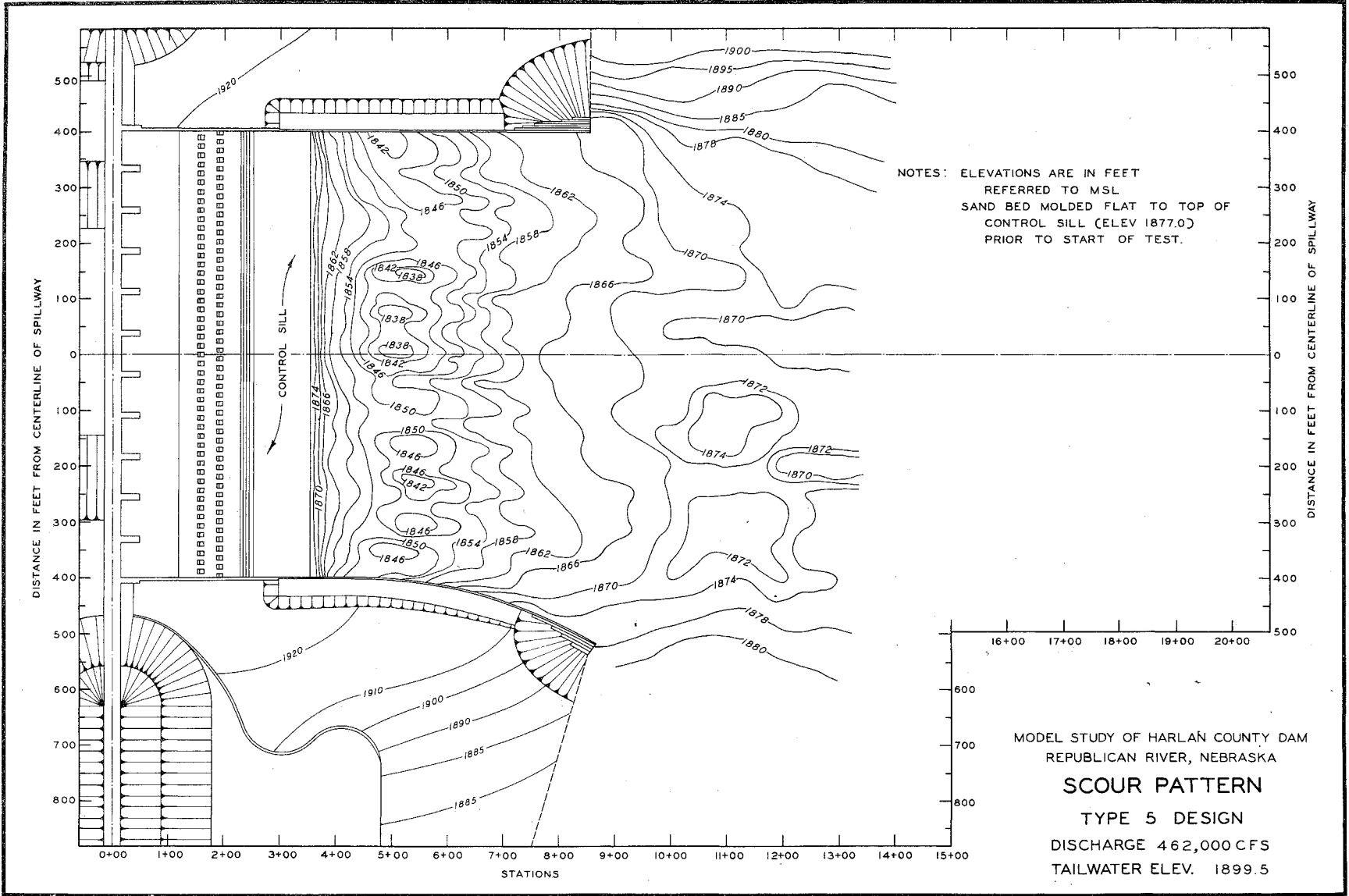

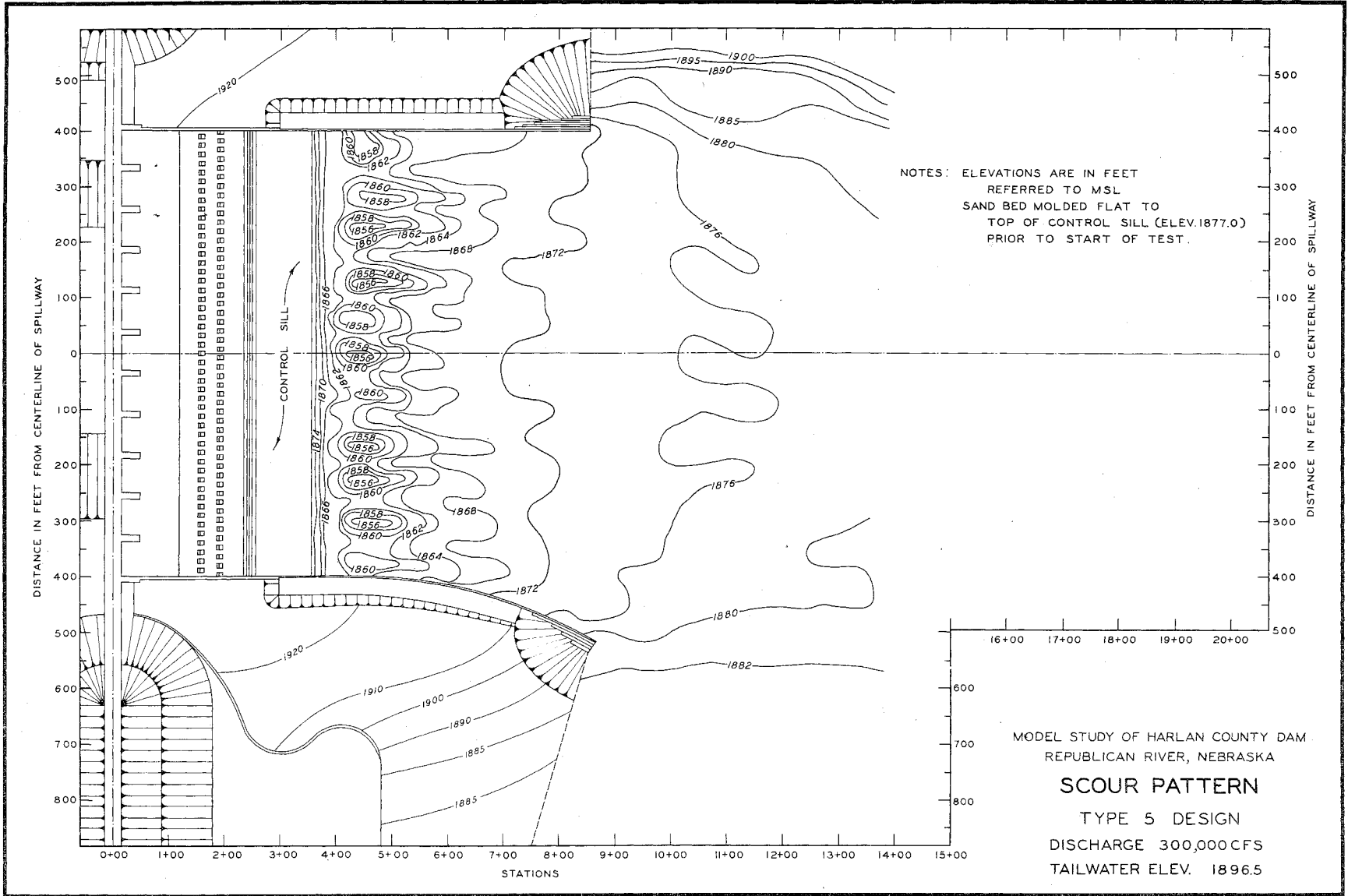

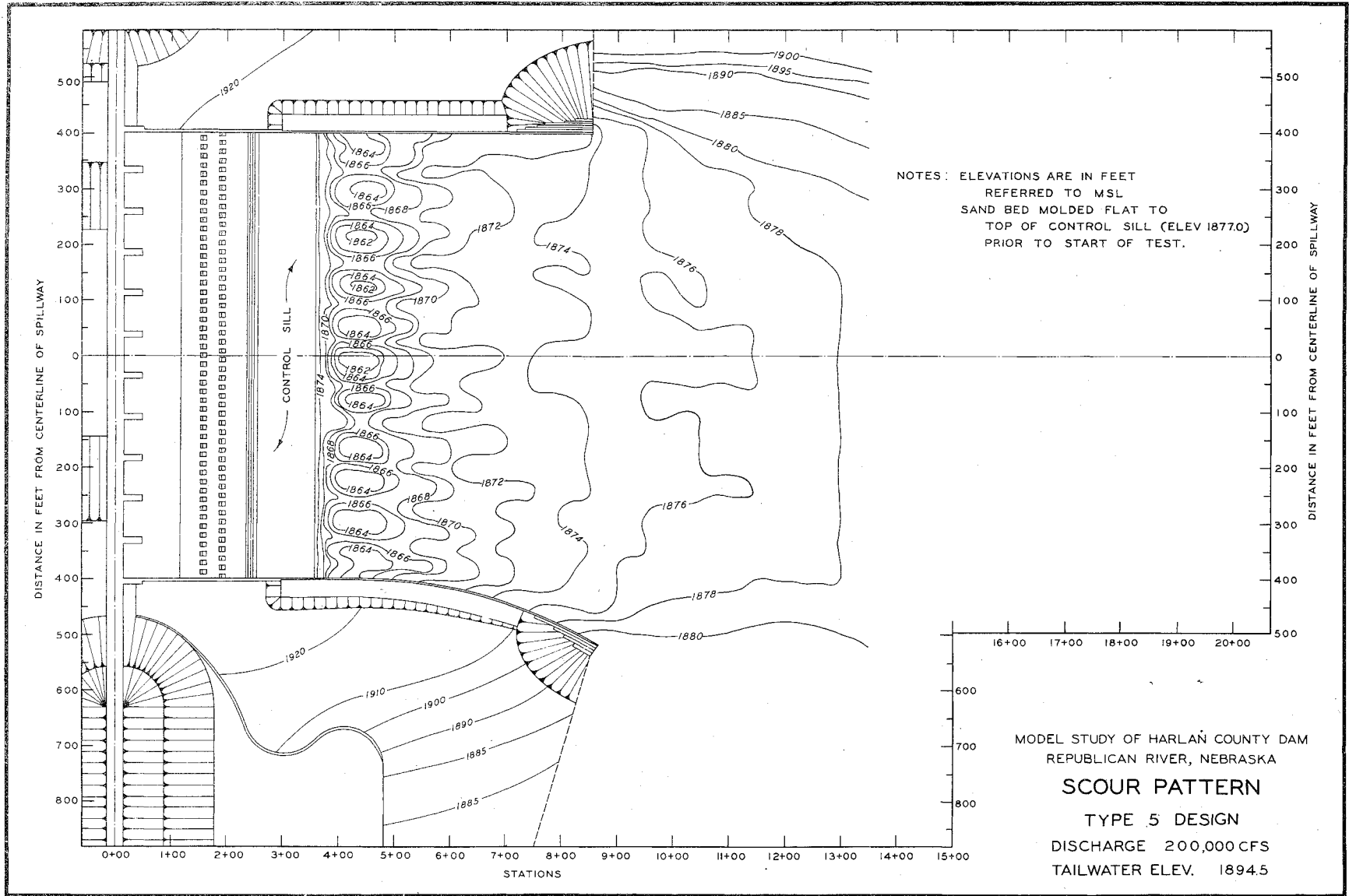

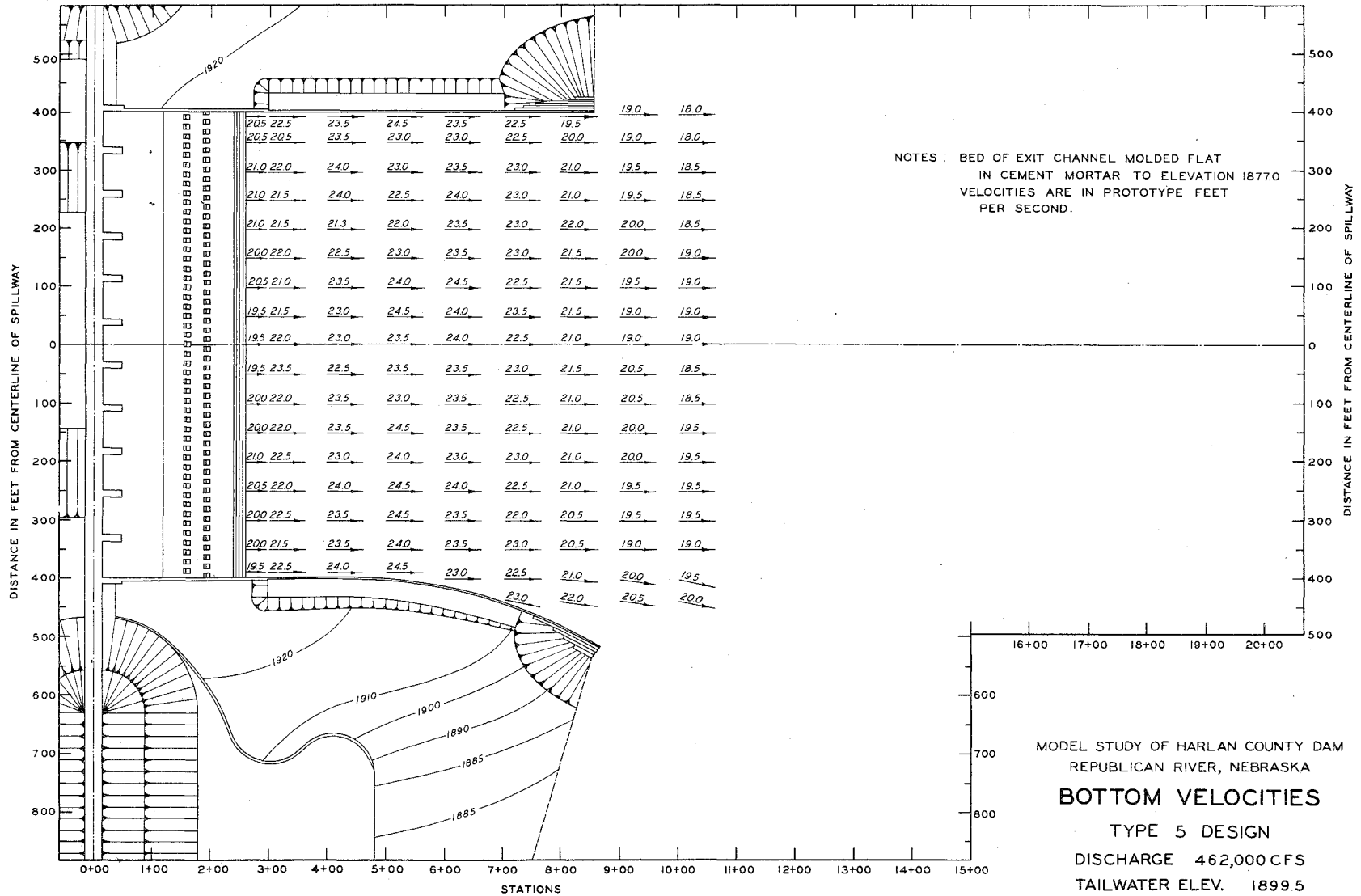

MODEL STUDY OF HARLAN COUNTY DAM
REPUBLICAN RIVER, NEBRASKA
BOTTOM VELOCITIES
TYPE 5 DESIGN
DISCHARGE 462,000 CFS
TAILWATER ELEV. 1899.5

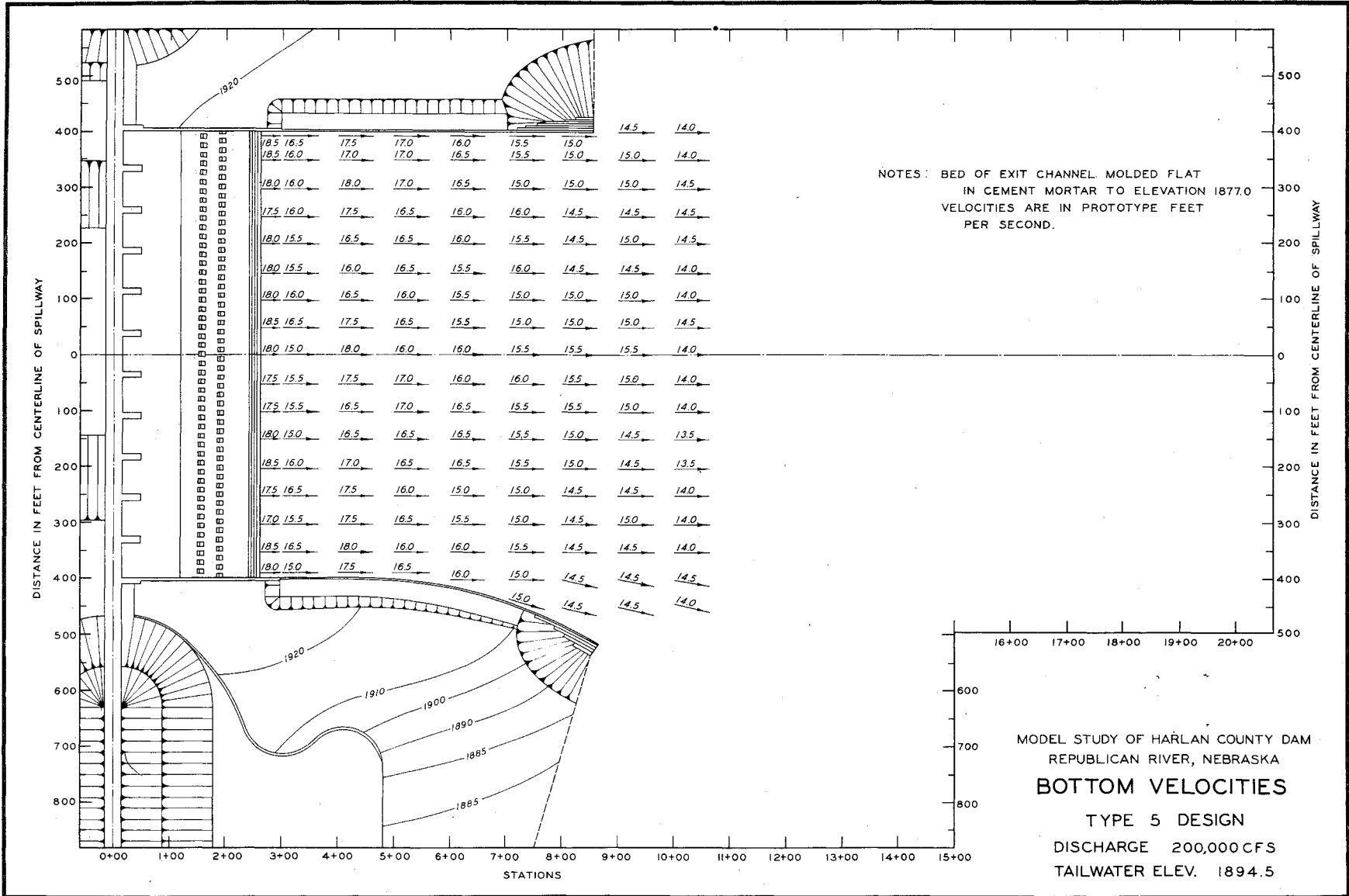

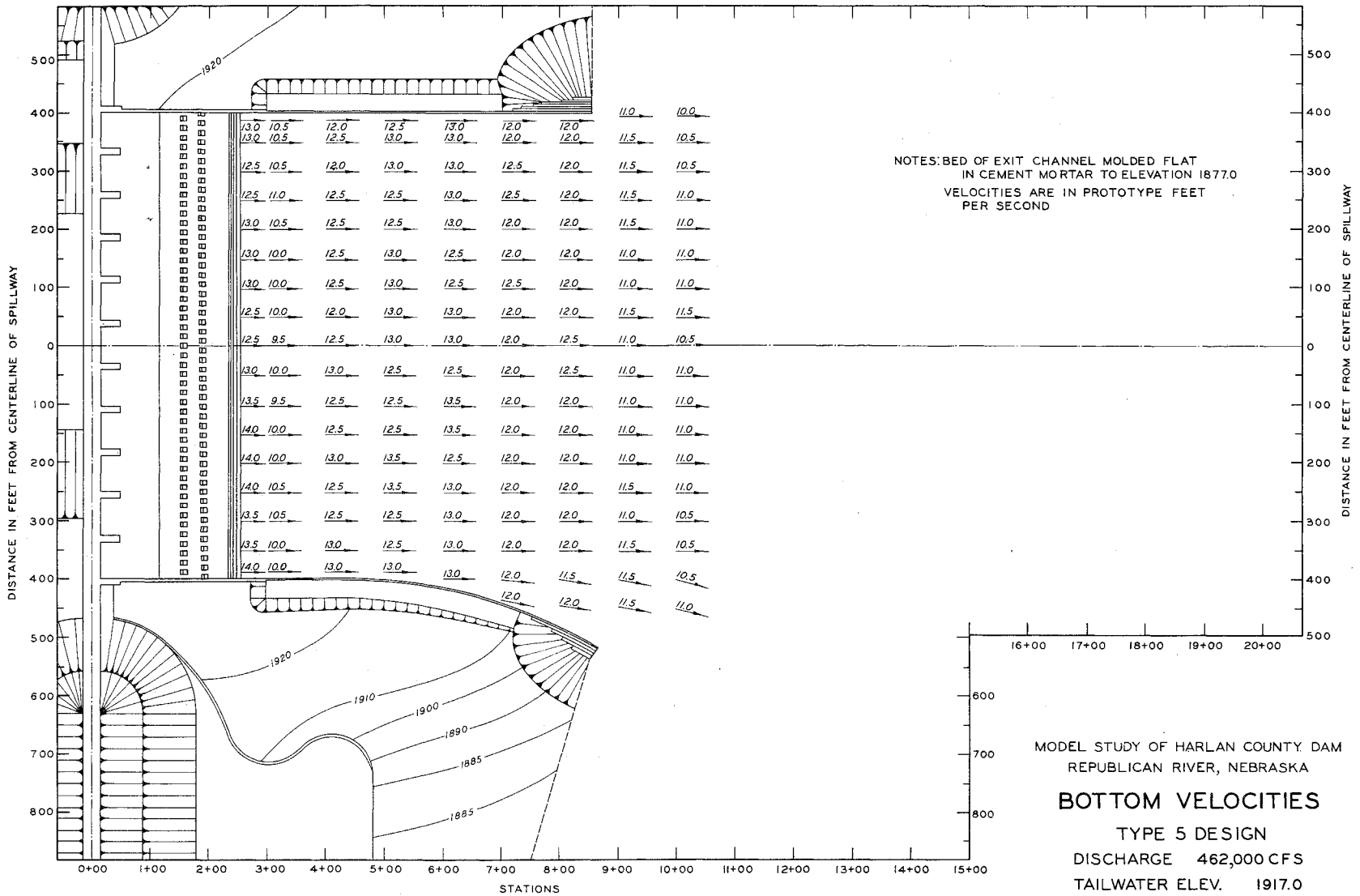

MODEL STUDY OF HARLAN COUNTY DAM
REPUBLICAN RIVER, NEBRASKA
BOTTOM VELOCITIES
TYPE 5 DESIGN
DISCHARGE 462,000 CFS
TAILWATER ELEV. 1917.0

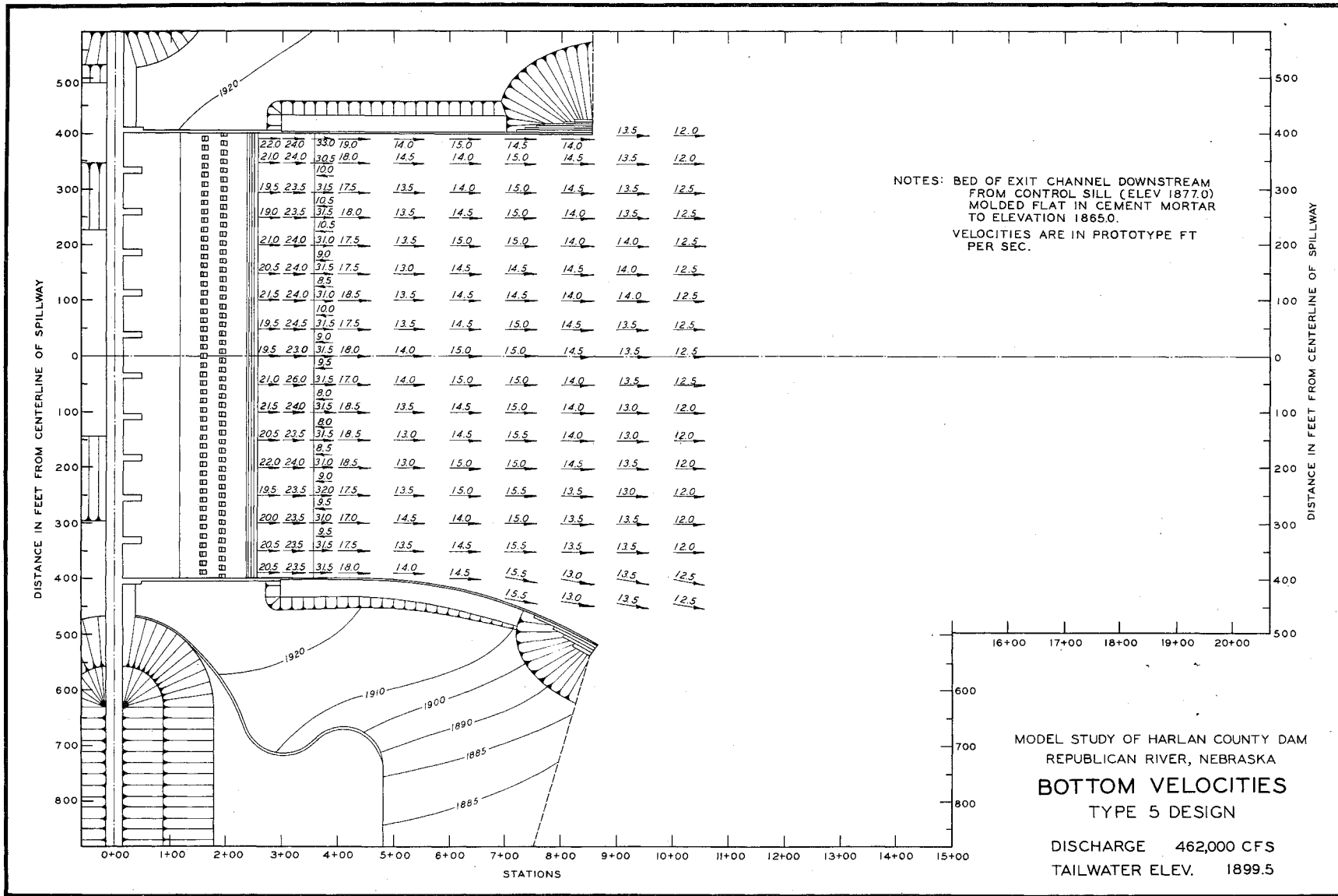

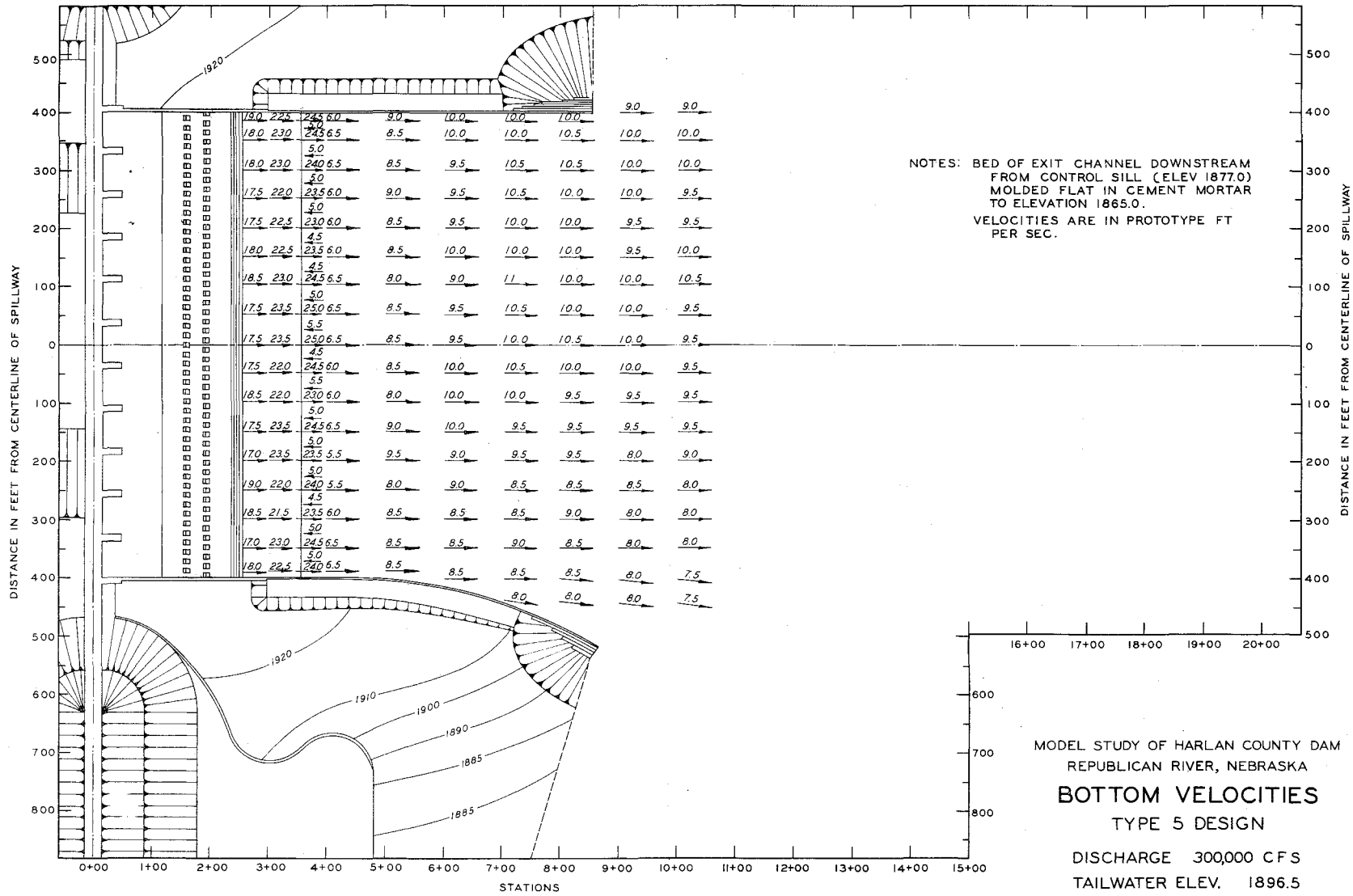

NOTES: BED OF EXIT CHANNEL DOWNSTREAM FROM CONTROL SILL (ELEV 1877.0) MOLDED FLAT IN CEMENT MORTAR TO ELEVATION 1865.0. VELOCITIES ARE IN PROTOTYPE FT PER SEC.

MODEL STUDY OF HARLAN COUNTY DAM
 REPUBLICAN RIVER, NEBRASKA
BOTTOM VELOCITIES
 TYPE 5 DESIGN
 DISCHARGE 300,000 CFS
 TAILWATER ELEV. 1896.5

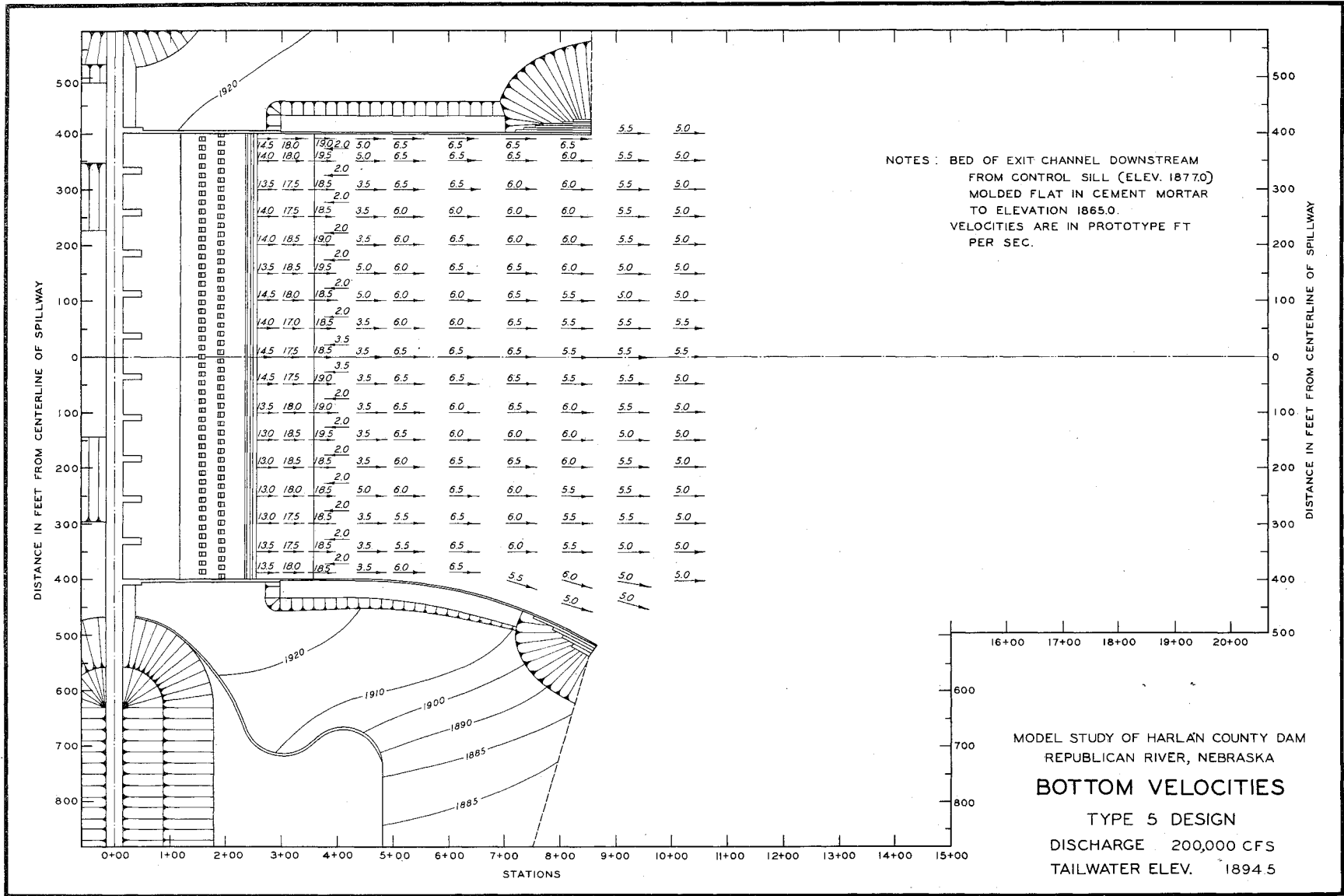

TEST DATA

DISCHARGE 462,000 CFS
TAILWATER ELEV 1899.5

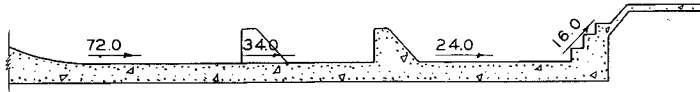

TEST DATA

DISCHARGE 462,000 CFS
TAILWATER ELEV 1899.5

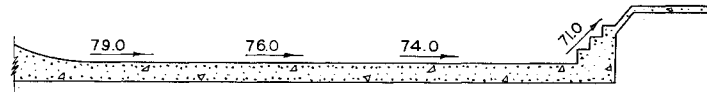

TEST DATA

DISCHARGE 300,000 CFS
TAILWATER ELEV 1896.5

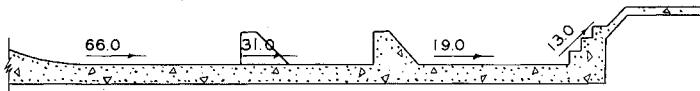

TEST DATA

DISCHARGE 300,000 CFS
TAILWATER ELEV 1896.5



TEST DATA

DISCHARGE 200,000 CFS
TAILWATER ELEV 1894.5

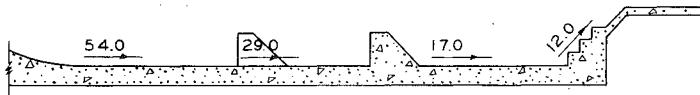

TEST DATA

DISCHARGE 200,000 CFS
TAILWATER ELEV 1894.5

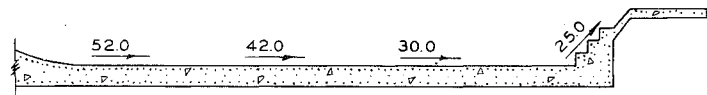

NOTES: VELOCITIES ARE AVERAGE VELOCITIES FOR TOTAL WIDTH
OF STILLING BASIN.
VELOCITIES ARE IN PROTOTYPE FEET PER SECOND.

MODEL STUDY OF HARLAN COUNTY DAM
REPUBLICAN RIVER, NEBRASKA

BOTTOM VELOCITIES
TYPE 5 DESIGN

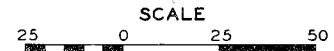

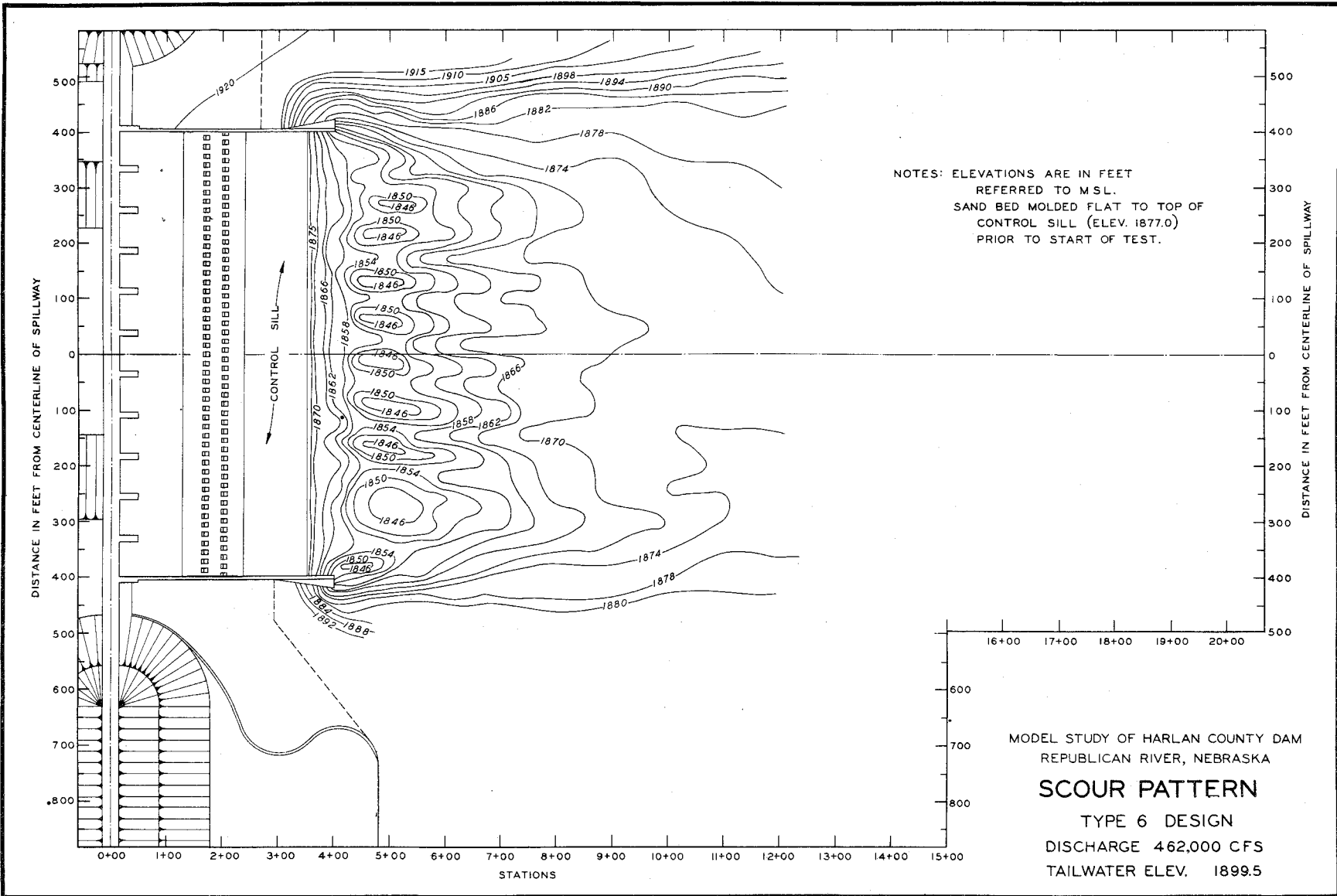

NOTES: ELEVATIONS ARE IN FEET
 REFERRED TO M.S.L.
 SAND BED MOLDED FLAT TO TOP OF
 CONTROL SILL (ELEV. 1877.0)
 PRIOR TO START OF TEST.

MODEL STUDY OF HARLAN COUNTY DAM
 REPUBLICAN RIVER, NEBRASKA
SCOUR PATTERN
 TYPE 6 DESIGN
 DISCHARGE 462,000 CFS
 TAILWATER ELEV. 1899.5

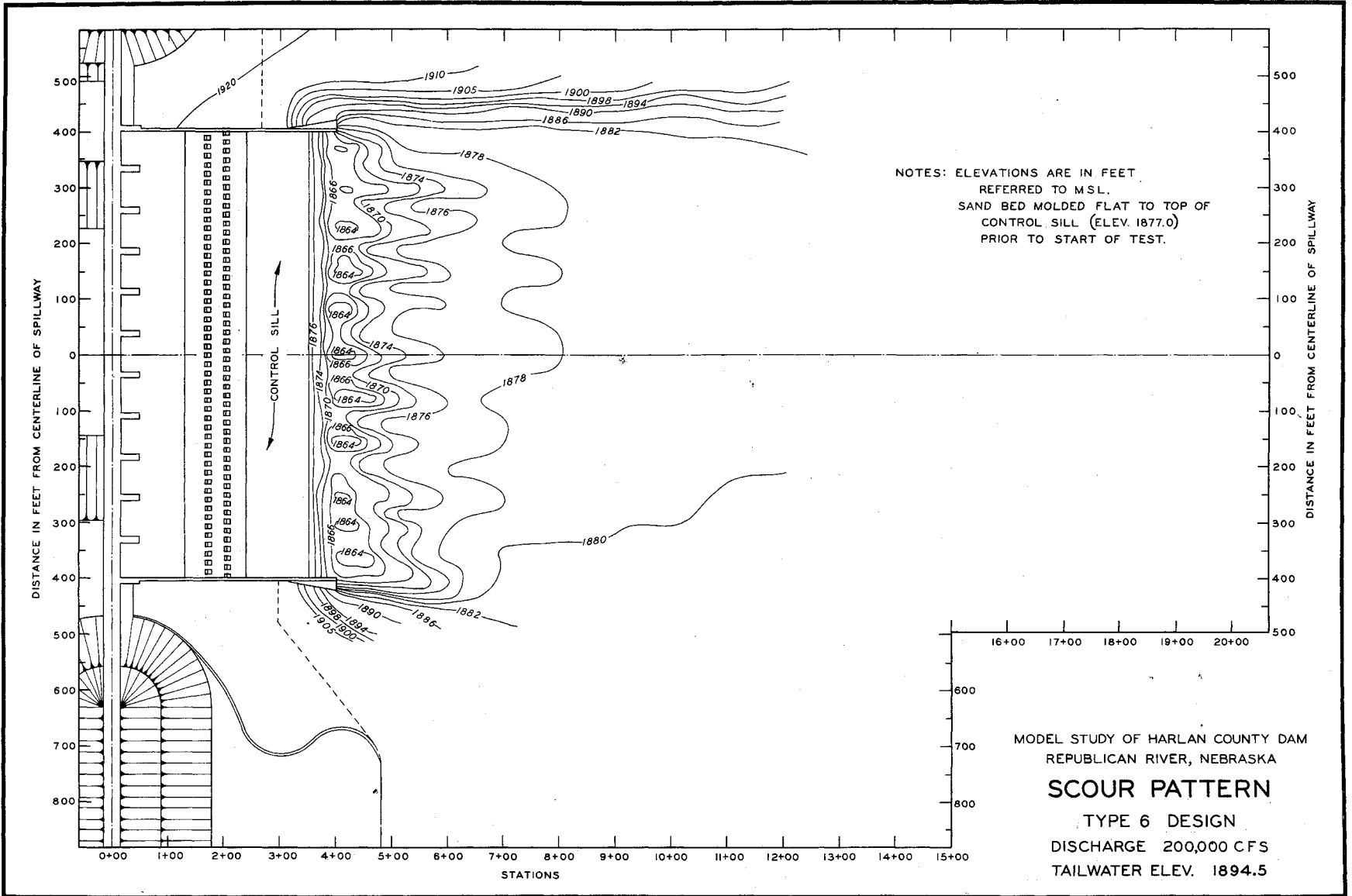

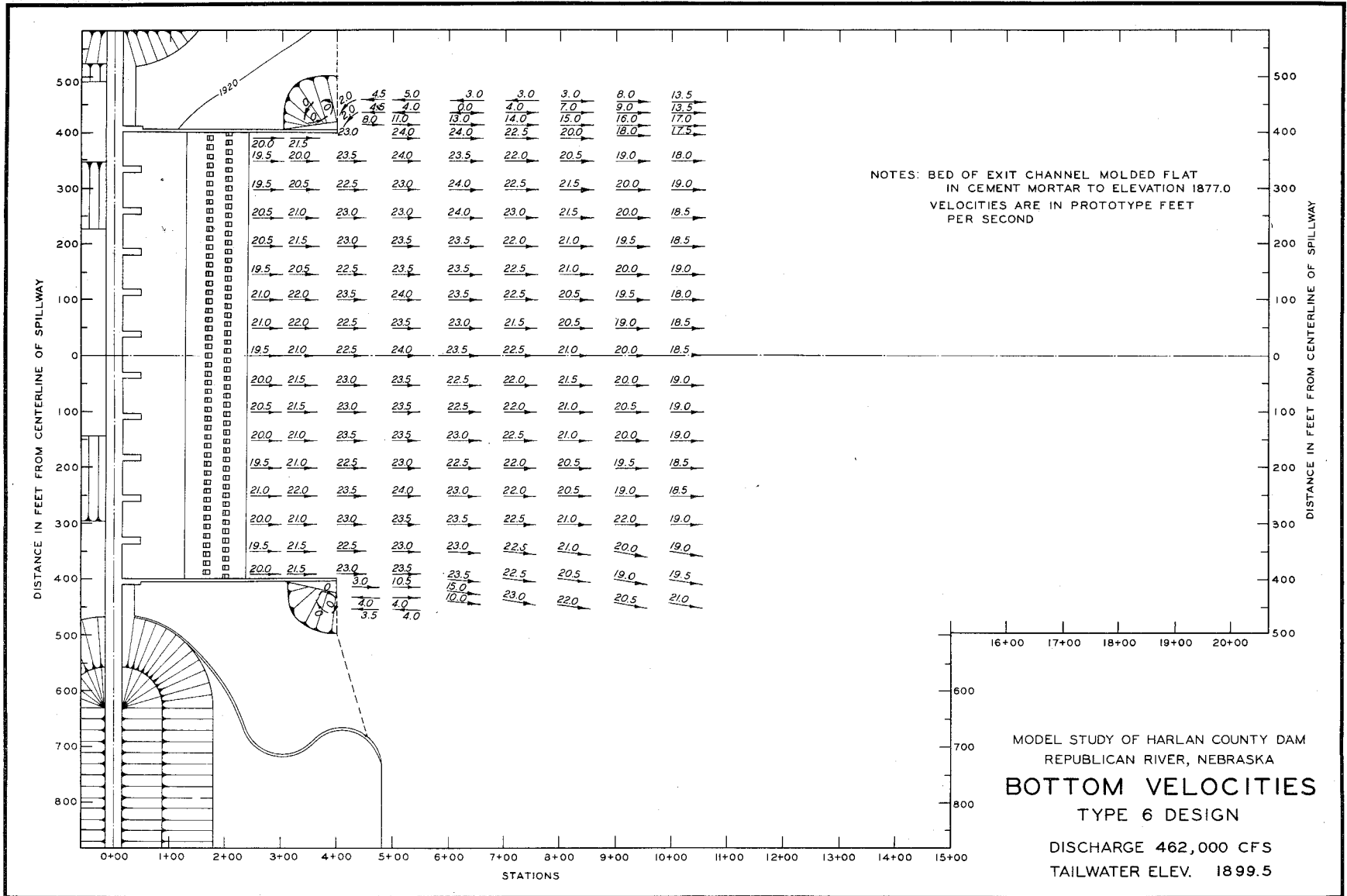

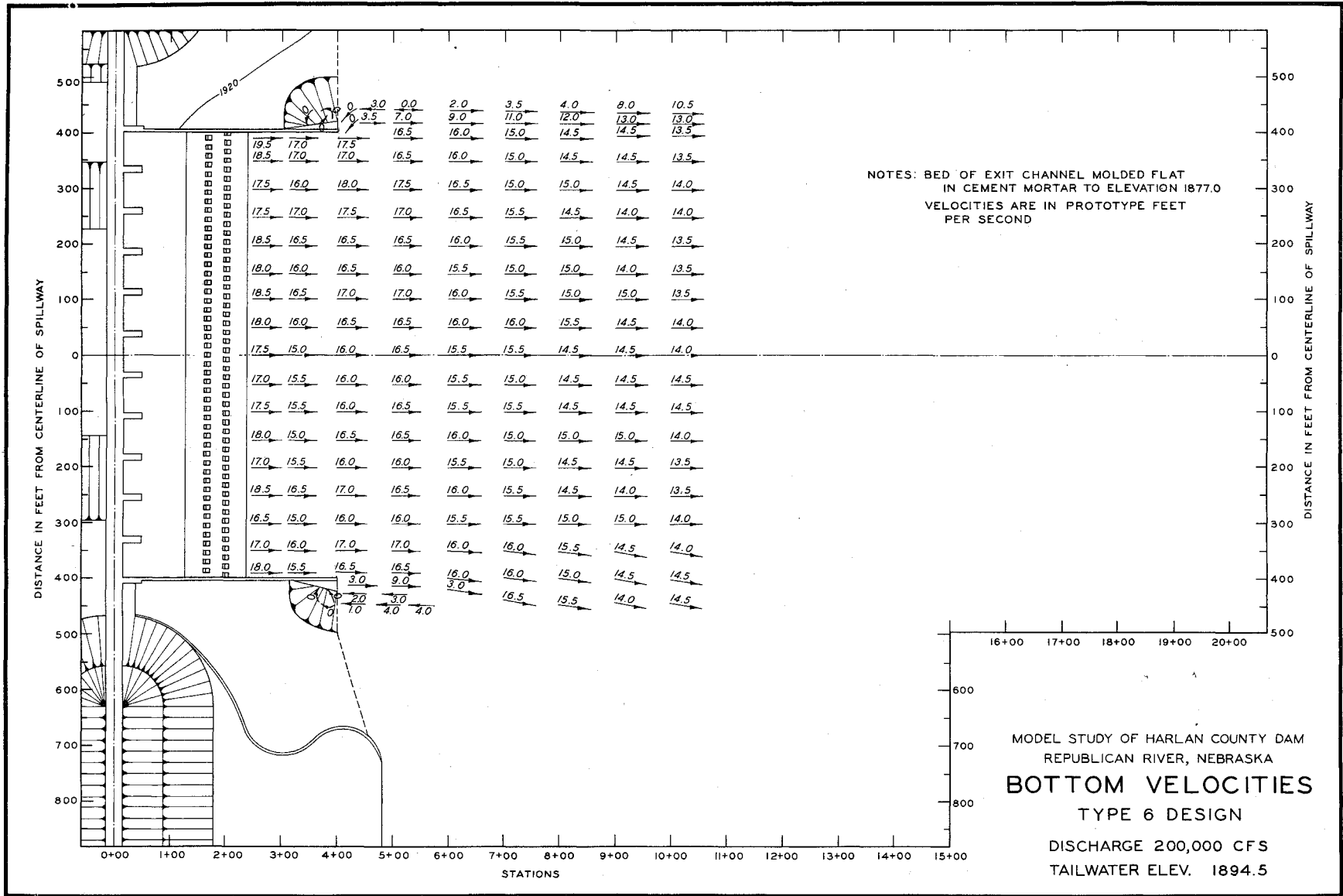

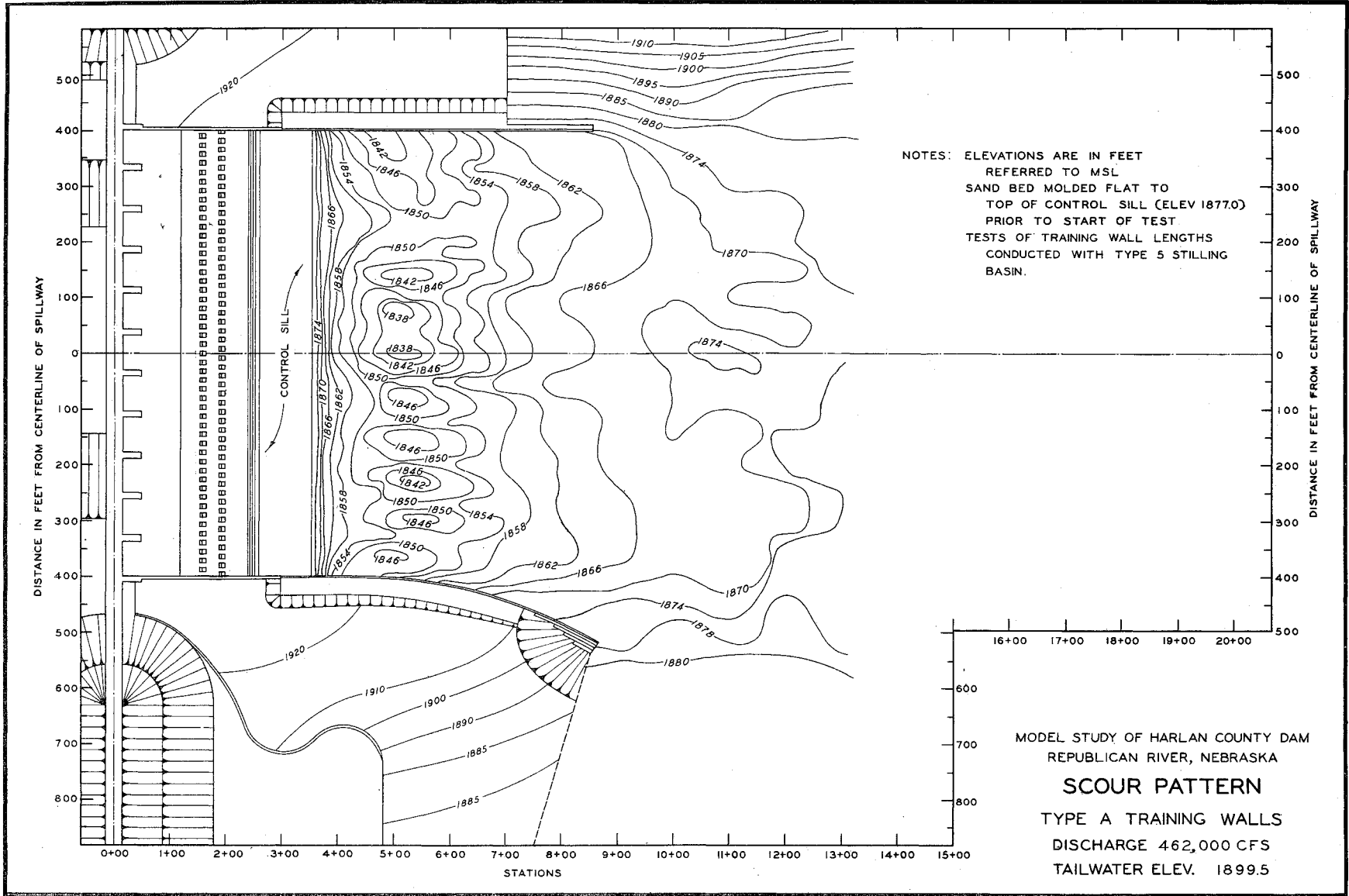

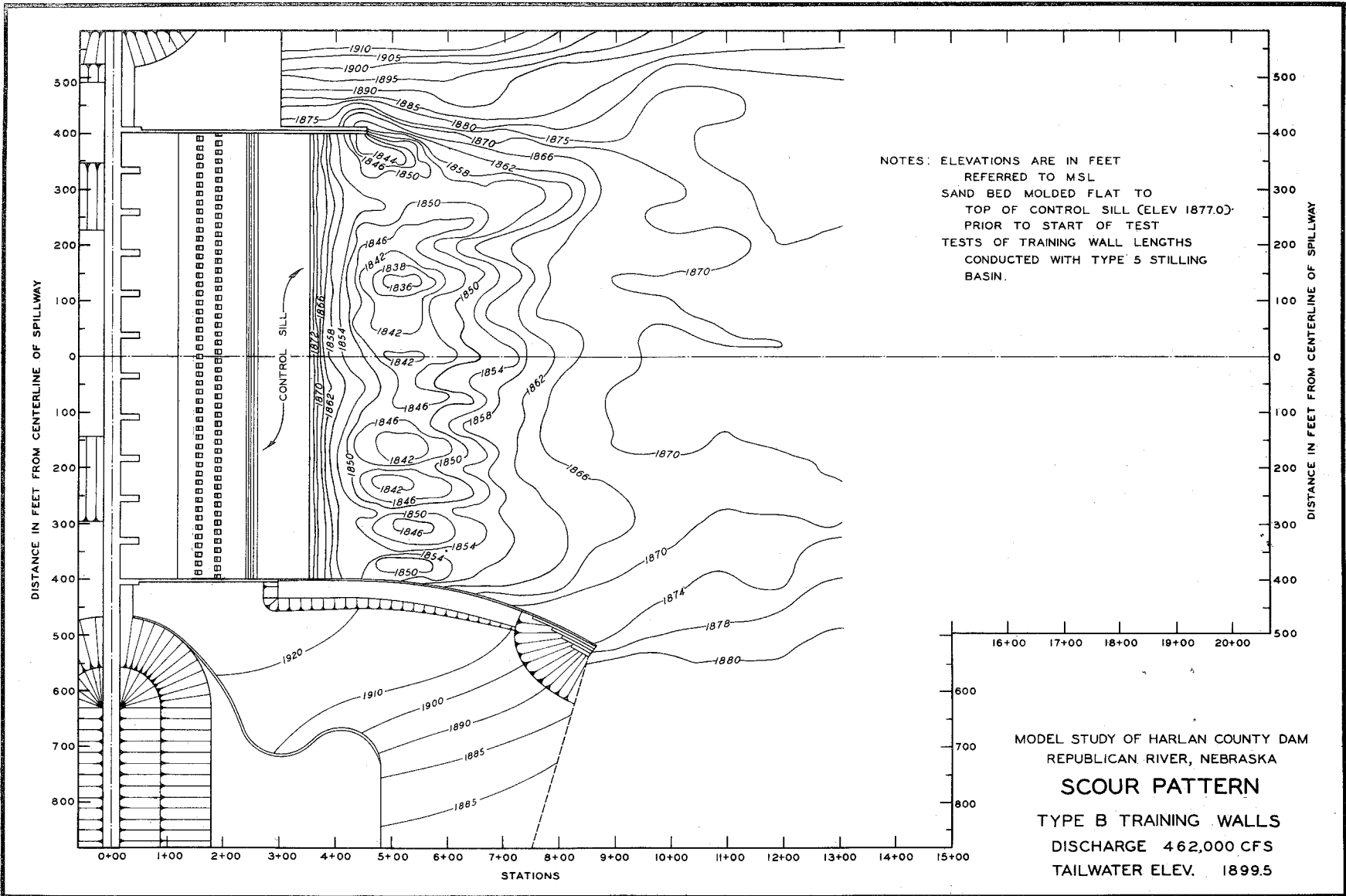

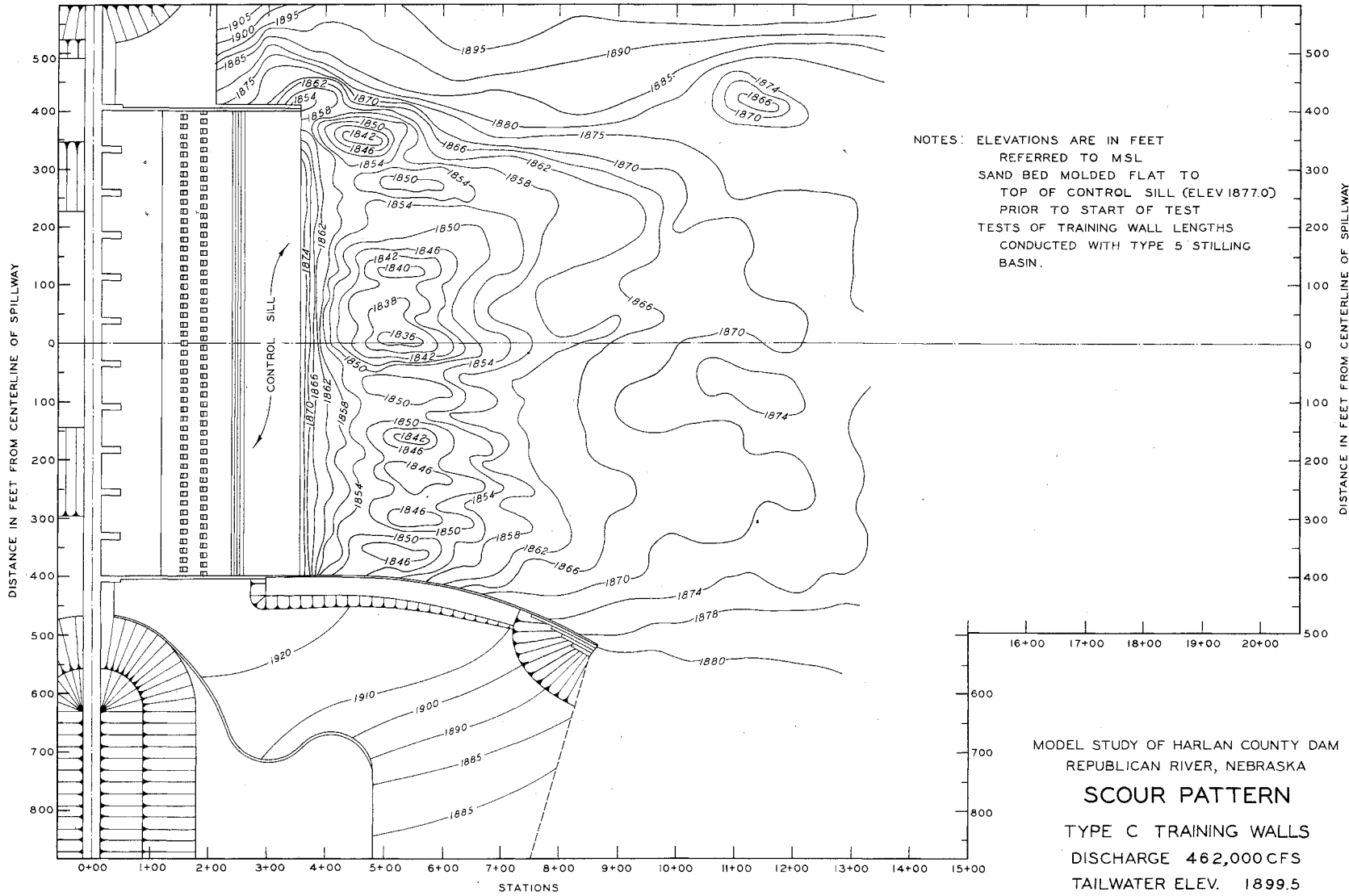

NOTES: ELEVATIONS ARE IN FEET
 REFERRED TO MSL
 SAND BED MOLDED FLAT TO
 TOP OF CONTROL SILL (ELEV 1877.0)
 PRIOR TO START OF TEST
 TESTS OF TRAINING WALL LENGTHS
 CONDUCTED WITH TYPE 5 STILLING
 BASIN.

MODEL STUDY OF HARLAN COUNTY DAM
 REPUBLICAN RIVER, NEBRASKA
SCOUR PATTERN
 TYPE C TRAINING WALLS
 DISCHARGE 462,000 CFS
 TAILWATER ELEV. 1899.5

