



AUTOMATED COASTAL ENGINEERING SYSTEM

USER'S GUIDE

by

David A. Leenknecht, Andre Szuwalski
and Ann R. Sherlock



Coastal Engineering Research Center

DEPARTMENT OF THE ARMY
Waterways Experiment Station, Corps of Engineers
3909 Halls Ferry Road, Vicksburg, Mississippi 39180-6199

Version 1.07
September 1992



HECSA TECHNICAL LIBRARY

Report Documentation Page

Form Approved
OMB No. 0704-0188

Public reporting burden for the collection of information is estimated to average 1 hour per response, including the time for reviewing instructions, searching existing data sources, gathering and maintaining the data needed, and completing and reviewing the collection of information. Send comments regarding this burden estimate or any other aspect of this collection of information, including suggestions for reducing this burden, to Washington Headquarters Services, Directorate for Information Operations and Reports, 1215 Jefferson Davis Highway, Suite 1204, Arlington VA 22202-4302. Respondents should be aware that notwithstanding any other provision of law, no person shall be subject to a penalty for failing to comply with a collection of information if it does not display a currently valid OMB control number.

1. REPORT DATE SEP 1992		2. REPORT TYPE		3. DATES COVERED 00-00-1992 to 00-00-1992	
4. TITLE AND SUBTITLE Automated Coastal Engineering System: User's Guide				5a. CONTRACT NUMBER	
				5b. GRANT NUMBER	
				5c. PROGRAM ELEMENT NUMBER	
6. AUTHOR(S)				5d. PROJECT NUMBER	
				5e. TASK NUMBER	
				5f. WORK UNIT NUMBER	
7. PERFORMING ORGANIZATION NAME(S) AND ADDRESS(ES) U.S. Army Corps of Engineers, Waterway Experiment Station, 3903 Halls Ferry Road, Vicksburg, MS, 39180				8. PERFORMING ORGANIZATION REPORT NUMBER	
9. SPONSORING/MONITORING AGENCY NAME(S) AND ADDRESS(ES)				10. SPONSOR/MONITOR'S ACRONYM(S)	
				11. SPONSOR/MONITOR'S REPORT NUMBER(S)	
12. DISTRIBUTION/AVAILABILITY STATEMENT Approved for public release; distribution unlimited					
13. SUPPLEMENTARY NOTES					
14. ABSTRACT					
15. SUBJECT TERMS					
16. SECURITY CLASSIFICATION OF:			17. LIMITATION OF ABSTRACT	18. NUMBER OF PAGES	19a. NAME OF RESPONSIBLE PERSON
a REPORT unclassified	b ABSTRACT unclassified	c THIS PAGE unclassified			

Destroy this report when no longer needed.
Do not return it to the originator.

The findings in this report are not to be construed as an official Department of the Army position unless so designated by other authorized documents.

The computer program and supporting technical data provided by the US Army Corps of Engineers in this package are received and accepted by the user with the express understanding that the Government makes no warranties, expressed or implied, regarding functionality, accuracy, or utility of the package or of the information generated by the package. **THE IMPLIED WARRANTIES OF MERCHANTABILITY AND OF FITNESS OR SUITABILITY FOR A PARTICULAR PURPOSE ARE SPECIFICALLY DISCLAIMED.** The Government also makes no representations that this package will meet the user's needs or requirements, will properly operate in the systems selected by the user, or will be uninterrupted or error free in the user's applications. Accordingly, it is recommended that each person or entity using or relying on this package undertake an independent assessment and thorough evaluation of his own requirements and needs before proceeding.

Further, this package is provided to and accepted by the user "as is" with any accompanying faults and defects. Any person or entity that relies upon information generated or obtained by this package does so at his own risk. The Government does not and cannot warrant the performance or results of this package under any and all circumstances. Therefore, no representations or claims are made about the completeness, accuracy, reliability, usability, or suitability of this package for any particular purpose or of any results derived by the use of this package.

Finally, the Government also disclaims all liability to users and third parties for damages including, but not limited to, direct, indirect, incidental, special, consequential, or any other damages whatsoever arising from, or in connection with, the use and results of this package. These disclaimers extend to any and all advice, interpretations, or other information given by Government personnel about the use or modification of the package.

Any references to products, tradenames, or trademarks herein are made for the purpose of illustration or clarification and do not constitute an official endorsement or approval of such items by the Government.

This program is the work of the United States Government and is in the public domain. It is approved for public release with unlimited distribution. It is improper and against Army policy to assist or encourage any advertisement, commercial product, or promotional activity which might imply Army endorsement for private benefit. Permission to use the Corps' name, materials, and activities can be obtained only under Army Regulation 360-5, dated 31 May 1989.

Copies of this software may be obtained from the Federal Software Exchange Center, National Technical Information Service, 5285 Port Royal Road, Springfield, VA 22161 or 703-487-4650.

PREFACE

The Automated Coastal Engineering System (ACES) is being developed by the Automated Coastal Engineering (ACE) Group, Research Division (RD), Coastal Engineering Research Center (CERC), US Army Engineer Waterways Experiment Station (WES). Funding for the effort is part of the Coastal Structures Evaluation and Design Research and Development Program. Messrs. John H. Lockhart, Jr., John G. Housley, Barry W. Holiday, and David Roellig are the Technical Monitors, Headquarters, US Army Corps of Engineers, for this program.

Development of the system was performed by Mr. David A. Leenknecht, Principal Investigator of the ACES, assisted by Mrs. Ann R. Sherlock, ACE Group. Contributors in the development were Miss Willie A. Brandon, Dr. Robert E. Jensen, Mr. Doyle L. Jones, Dr. Edward F. Thompson, CERC, Mr. Michael E. George, Information Technology Laboratory (ITL), and Mr. David W. Hyde, Structures Laboratory, WES; former CERC employees who also made contributions include Mr. John Ahrens, National Oceanic and Atmospheric Administration Sea Grant, Silver Spring, MD; Dr. Mark R. Byrnes, Louisiana State University, Baton Rouge, LA; Mr. Peter L. Crawford, US Army Engineer (USAE) District, Buffalo (NCB); Miss Leslie M. Fields, Aubrey Consultants Incorporated, Falmouth, MA; Mr. James M. Kaihatu, University of Delaware, Newark, DE; and Mr. Kent A. Turner, USAE Division, Lower Mississippi Valley. This report was edited by Mrs. Janean Shirley, ITL, WES.

The work was performed under the general supervision of Dr. James R. Houston, Director, CERC; Mr. Charles C. Calhoun, Jr., Assistant Director, CERC; Ms. Carolyn M. Holmes, CERC Coastal Program Manager; Mr. H. Lee Butler, Chief, RD; and under the direct supervision of Mr. Andre Szuwalski, Chief, ACE Group. Commander and Deputy Director of WES during publication of this guide was COL Leonard G. Hassell, EN. Dr. Robert W. Whalin was the Director of WES.

A Corps-wide Pilot Committee of coastal specialists guides the direction of the ACES effort. Members of the ACES Pilot Committee during this period were Mr. George Domurat, (Chairman), USAE Division, South Pacific (SPD); Mr. Dave Timpy, (Vice-Chairman), USAE District, Wilmington; Mr. John Oliver, USAE Division, North Pacific; Mr. Doug Pirie, SPD; Mr. Peter Crawford, NCB; Mr. Doug Gaffney, USAE District, Philadelphia; Ms. Cheryl Ulrich, USAE District, Mobile; Mr. Housley; and Dr. C. Linwood Vincent (CERC).

TABLE OF CONTENTS

Preface	i
Introduction	v
General Goals of the ACES	v
ACES Contents	v
Target Hardware Environment	v
Document Overview	vi
Reference	vii
General Instructions and Information	ix
User Interface	ix
Starting	ix
Ending	ix
Definitions	ix
Modes	x
Single Case Mode Execution	x
Multiple Case Mode Execution	x
Exceptions	xi
General Data Specifications	xi
System of Units	xi
General Water Type	xi
Title	xi
Print File/Device	xi
Page Ejects	xii
Files	xii
Trace Output File	xii
Plot Output Files	xii
Defaults	xiii
Errors	xiii
Instructions for Individual Applications	
Wave Prediction Functional Area	
Windspeed Adjustment and Wave Growth	1-1
Beta-Rayleigh Distribution	1-2
Extremal Significant Wave Height Analysis	1-3
Constituent Tide Record Generation	1-4
Wave Theory Functional Area	
Linear Wave Theory	2-1
Cnoidal Wave Theory	2-2

Fourier Series Wave Theory	2-3
Wave Transformation Functional Area	
Linear Wave Theory with Snell's Law	3-1
Irregular Wave Transformation (Goda's Method)	3-2
Combined Diffraction and Reflection by a Vertical Wedge	3-3
Structural Design Functional Area	
Breakwater Design Using Hudson and Related Equations	4-1
Toe Protection Design	4-2
Nonbreaking Wave Forces at Vertical Walls	4-3
Rubble-Mound Revetment Design	4-4
Wave Runup, Transmission, and Overtopping Functional Area	
Irregular Wave Runup on Beaches	5-1
Wave Runup and Overtopping on Impermeable Structures	5-2
Wave Transmission on Impermeable Structures	5-3
Wave Transmission Through Permeable Structures	5-4
Littoral Processes Functional Area	
Longshore Sediment Transport	6-1
Numerical Simulation of Time-Dependent Beach and Dune Erosion	6-2
Calculation of Composite Grain-Size Distributions	6-3
Beach Nourishment Overfill Ratio and Volume	6-4
Inlet Processes Functional Area	
A Spatially Integrated Numerical Model for Inlet Hydraulics	7-1

Appendices

Appendix A: Tables	A
Appendix B: Hardware and Installation	B
Appendix C: Graphics Options	C
Appendix D: Input/Output Options	D

INTRODUCTION

GENERAL GOALS OF THE ACES

The Automated Coastal Engineering System (ACES) is an interactive computer-based design and analysis system in the field of coastal engineering. In response to a charge by the Chief of Engineers, LTG E. R. Heiberg III, to the Coastal Engineering Research Board (US Army Engineer Waterways Experiment Station, 1985) to provide improved design capabilities to Corps coastal specialists, the Coastal Engineering Research Center (CERC) conducted a series of six regional workshops in July 1986 to gather input from Corps field offices concerning various aspects of an ACES. Subsequent to the workshops, the ACES Pilot Committee and various working committees were formed from coastal experts throughout the Corps, and the Automated Coastal Engineering (ACE) Group was formed at CERC. The general goal of the ACES is to provide state-of-the-art computer-based tools that will increase the accuracy, reliability, and cost-effectiveness of Corps coastal engineering endeavors.

ACES CONTENTS

Reflecting the nature of coastal engineering, methodologies contained in this release of the ACES are richly diverse in sophistication and origin. The contents range from simple algebraic expressions, both theoretical and empirical in origin, to numerically intense algorithms spawned by the increasing power and affordability of computers. Historically, the methods range from classical theory describing wave motion, to expressions resulting from tests of structures in wave flumes, and to recent numerical models describing the exchange of energy from the atmosphere to the sea surface. In a general procedural sense, much has been taken from previous individual programs on both mainframes and microcomputers.

The various methodologies included in ACES are called **applications** and are organized into categories called **functional areas** differentiated according to general relevant physical processes and design or analysis activities. A list of the applications currently resident in the ACES is given in the table on the next page.

TARGET HARDWARE ENVIRONMENT

A strong preference expressed in the workshops and subsequent meetings was for the system to reside in a desktop hardware environment. To meet this preference, the ACES is designed to reside on the current base of PC-AT class of personal computers resident at many Corps coastal offices. While expected to migrate to more powerful hardware technologies, this current generation of ACES is designed for the above environment and is written in FORTRAN 77.

DOCUMENT OVERVIEW

The documentation set for the ACES comprises two manuals: *Technical Reference* and *User's Guide*.

- * The *Technical Reference* contains theory and discussion of the various methodologies contained in the ACES. The material included in the *Technical Reference* is relatively brief. For essential features of derivations and mathematical manipulations of equations presented in each section of this manual, the reader is strongly directed to references presented at the end of each application description.
- * The *User's Guide* contains instructions for using individual applications within the ACES software package.

Current ACES Applications	
Functional Area	Application Name
Wave Prediction	Windspeed Adjustment and Wave Growth Beta-Rayleigh Distribution Extremal Significant Wave Height Analysis Constituent Tide Record
Wave Theory	Linear Wave Theory Cnoidal Wave Theory Fourier Series Wave Theory
Wave Transformation	Linear Wave Theory with Snell's Law Irregular Wave Transformation (Goda's method) Combined Diffraction and Reflection by a Vertical Wedge
Structural Design	Breakwater Design Using Hudson and Related Equations Toe Protection Design Nonbreaking Wave Forces on Vertical Walls Rubble-Mound Revetment Design
Wave Runup, Transmission, and Overtopping	Irregular Wave Runup on Beaches Wave Runup and Overtopping on Impermeable Structures Wave Transmission on Impermeable Structures Wave Transmission Through Permeable Structures
Littoral Processes	Longshore Sediment Transport Numerical Simulation of Time-Dependent Beach and Dune Erosion Calculation of Composite Grain-Size Distribution Beach Nourishment Overfill Ratio and Volume
Inlet Processes	A Spatially Integrated Numerical Model for Inlet Hydraulics

REFERENCE

US Army Engineer Waterways Experiment Station. 1985. *Proceedings of the 44th Meeting of the Coastal Engineering Research Board*, 4-6 November 1985, Sausalito, California, James R. Houston, Editor, Vicksburg, MS, pp. 11-21.

GENERAL INSTRUCTIONS AND INFORMATION

USER INTERFACE

This version of the Automated Coastal Engineering System (ACES) employs a menu-driven environment. Menus are displayed on the screen, and in general, single keystrokes (usually the **F1**-**F10** function keys) are required to select activities or options in the system. Cursor keys are used to select between highlighted input fields (displayed in reverse video). Some applications allow input through data saved in an external file. Results from computations are normally displayed in tabular format on the screen and/or written to print files or devices and/or displayed as plots. Appendix D is a summary table listing the input and output options for the applications available in this version of ACES.

STARTING

Appendix B provides installation instructions for the ACES software including graphics options. (Appendix C specifically discusses the graphics options.) The installation procedure described in Appendix B suggests copying the ACES files into a subdirectory called ACES107. To begin a session:

1. Type `CD\ACES107` and press **ENTER**.
2. Type `ACES` and press **ENTER**.

The Main Menu of ACES is displayed, and single keystrokes become the primary selection mechanism for the session.

ENDING

From any point in the system, repeated use of the **F10** key returns to successively higher menu levels and, ultimately, back to DOS. Exceptions occur when lengthy computations are in progress (they must be allowed to finish) and when incorrect data have been specified in interactive input fields (valid data must be respecified).

DEFINITIONS

An individual methodology included in the system is called an *application* and is assigned to a *functional area* according to its general end product. An operational *mode* (Single or Multiple Case) describes the type of general activity or type of input associated with a given session. This information is displayed on the screen while applications are executed in the system.

MODES

The Main Menu of ACES provides access to two (with some exceptions) separate operational modes:

<u>Option</u>	<u>Main Activity (Mode)</u>
F1	Single Case Mode
F2	Multiple Case Mode

It also provides an **F10** option to exit the system. Each of the modes is discussed below.

Single Case Mode Execution

This is one of the two execution modes requiring active participation with an application. From the Functional Area Menu, a specific application is selected from successive menus. Data for a single case are specified by moving the cursor to highlighted data input fields and specifying the value; results are displayed on the screen and can optionally be sent to a print file or device. Errors are identified, and recovery by respecification of the data is allowed. Successive execution with new values (all or individual data items ... called a new case) is an option.

Multiple Case Mode Execution

Like Single Case Mode, this execution mode is interactively selected from successive menus and also requires active participation with an application, but allows specification of sets of data values for most input variables. Sets of data are specified by declaring a range of values (minimum, maximum, and increment) or up to 20 discrete values for each variable in highlighted fields on the display screen. After entry of all sets of data (for all input variables), the permutations of the data sets are processed as discrete cases. Intended primarily for performing sensitivity or economic analysis, the Multiple Case Mode provides a powerful mechanism for looking at the effects of ranges of data. Execution results are written to the print file or device only.

CAUTION: Care should be taken to process a reasonable number of cases. (For convenience, the total number of cases to be processed is displayed.) *There are no limits imposed by the system to the number of cases possibly generated by using an incremental specification.*

NOTE: The most effective way to use the Multiple Case Mode is to pick one parameter and assign it multiple values, and assign only *one* value to the remaining parameters.

Exceptions

Not all applications will have access to both operational modes. There are a number of applications that allow only a Single Case Mode. In these applications, the Single Case Mode will normally have two options of interaction. The first option allows entering initial or new data as described above. The second option allows direct editing of a previously created data file for the particular application (see section entitled **Trace Output File**).

GENERAL DATA SPECIFICATIONS

For a given session, the information listed below is considered constant for all activities and is specified only once after selection of an operational mode from the Main Menu.

System of Units

This item refers to the general system of units in which results are displayed and printed (US Customary or Metric). Input variables are permitted many units, but final summaries are reported in the selected system of units. Specific units for each variable are itemized in the documentation for each application. The default is **US CUSTOMARY**.

NOTE: The terms US Customary and English units are used interchangeably in this document.

General Water Type

Choose between sea or fresh water. Average fluid properties are assumed based upon this specification. The default is **SEA** water.

Title

A 65-character title block is provided for unique identification of results from a given session. This title block is printed as part of the page banner (under the Project heading) on printed output.

Print File/Device

Specify the name of the target DOS device or file name (including directory path) for all output selected for printing. The default is **LPT1**.

NOTE: All file (including directory path) and device names are restricted to 20 characters.

Page Ejects

When running in Single Case Mode, the printer can be forced to print the output results of each application processed on a separate page. This could use much paper if many cases are processed. The default is **NO** page ejects.

Files

A number of input and output files are handled by the system. File overwrite protection is provided by the ACES package with optional overrides offered to the user for existing files; actual file names should be specified for maximum protection and efficiency. Specific input and output files are discussed below.

Trace Output File

Certain applications allow input via an existing file. These same applications also record the history of input during a session by writing the input data to a file. Any valid DOS file name (including directory path) may be specified for this file. The default file is named **TRACE.OUT**. If the file **TRACE.OUT** already exists, a warning message is displayed at the bottom of the screen. The following file-handling options are then displayed and available:

- F1** Replace it.
Existing data in the **TRACE.OUT** file will be deleted and a new **TRACE.OUT** file created.
- F2** Choose another file.
This option allows the user to rename the **TRACE.OUT** file, thus saving the data created in an earlier session. Any valid DOS file name (including directory path) may be specified.
- F3** Append output to it.
This option will append any input during the present session to the existing **TRACE.OUT** file.
- F10** Return to previous menu.

Plot Output Files

These files will contain output data generated by certain applications. The files can then be used outside the ACES environment. The specific content and format of these files are described in the section of this manual that describes the application which generates them. Default names are

PLOTDAT1.OUT, PLOTDAT2.OUT, PLOTDAT3.OUT. If any of these files already exist when an ACES session is begun, a warning message is displayed at the bottom of the screen, and the same file-handling options that were available for the **TRACE.OUT** file are then displayed.

DEFAULTS

Default values appear in the data fields of many applications in Single Case Mode. These values are for demonstration purposes only. Actual data should always be specified for variables in the applications. After the first execution of an application within a session, data are retained from case to case until changed.

ERRORS

Errors are reported on the display screen, but corrected differently for the two execution modes. In general, errors may be corrected in Single and Multiple Case Modes.

WINDSPEED ADJUSTMENT AND WAVE GROWTH

TABLE OF CONTENTS

Description	1-1-1
Procedure	1-1-1
Single Case Mode	1-1-1
Input	1-1-1
Main Input Screen	1-1-2
Specific Parameters	1-1-2
Wind Observation Type	1-1-3
Wind Fetch Options	1-1-3
Open-Water Wave Growth Equations Requestor	1-1-4
Average Depth of Fetch Requestor	1-1-5
Restricted Fetch Requestor	1-1-5
Keyboard Data Entry Requestor	1-1-7
Fetch Geometry Data Entry Screen	1-1-8
Data File Entry Requestor	1-1-9
Output	1-1-11
Multiple Case Mode	1-1-12
Input	1-1-12
Main Input Screen	1-1-12
Wind Observation Type	1-1-13
Wind Fetch Options	1-1-13
Open-Water Wave Growth Equations Requestor	1-1-13
Restricted Fetch Requestor	1-1-14
Specific Parameters Data Entry Screen	1-1-15
Output	1-1-16
Example Problems	1-1-17
Example 1 - Offshore to Onshore Winds - Open-Water Fetch - Shallow-Water Wave Equations	1-1-17
Example 2 - Shipboard Wind Observation - Open-Water Fetch - Deepwater Wave Equations	1-1-18
Example 3 - Overwater Wind Observation - Deepwater Wave Equations - Restricted Fetch	1-1-19
References and Bibliography	1-1-21

WINDSPEED ADJUSTMENT AND WAVE GROWTH

DESCRIPTION

The methodologies presented in this ACES application provide quick and simple estimates for wave growth over open-water and restricted fetches in deep and shallow water. Also, improved methods (over those given in the *Shore Protection Manual* (SPM), 1984) are included for adjusting the observed winds to those required by wave growth formulas. Because of the complexity of this methodology and the input requirements, familiarization with the *Technical Reference* for this application is strongly recommended.

PROCEDURE

This section provides instructions for running this application in the **Single Case** and **Multiple Case** modes.

Single Case Mode

The bulleted items listed below provide instructions for accessing the application.

- Press **F1** on the Main Menu to select Single Case Mode.
- Fill in the highlighted input fields on the General Specifications screen (or leave the default values). Press **F1** when all data on this screen are correct.
- Press **F1** on the Functional Area Menu to select Wave Prediction.
- Press **F1** on the Wave Prediction Application Menu to select Windspeed Adjustment and Wave Growth.

Input

For the **Single Case Mode**, data input for this application is accomplished through one main input screen, plus some support screens (for restricted fetch geometry), and several *pop-up windows* (hereafter called *requestors* in this document) that request additional specific data or choices between menu-style items. These are described in the following section.

Main Input Screen

The main input screen for the **Single Case Mode** is shown in Figure 1-1-1. It is used for entering data values and corresponding units for six *specific parameters*, and choosing between six *Wind Observation Types* and two *Wind Fetch Options*. Final results from the computations are displayed on this screen.

Item	Value	Units
Elevation of Observed Wind	Z _{obs} : ?	?
Observed Wind Speed	U _{obs} : ?	?
Air Sea Temp. Diff.	ΔT: ?	?
Dur of Observed Wind	DurO: ?	?
Dur of Final Wind	DurF: ?	?
Lat. of Observation	LAT: ?	deg
Wind Fetch Length	F:	
Eq Neutral Wind Spd	U _e :	
Adjusted Wind Speed	U _a :	
Wave Height	H _{mo} :	
Wave Period	T _p :	sec

Wave Growth:

↓	Wind Obs Type
	Overwater (ship)
	Overwater
	Shore (windward)
	Shore (leeward)
	Inland
	Geostrophic

↓	Wind Fetch Options
	Open Water
	Restricted

Options:
 F1: Proceed
 F10: Exit Applic

Figure 1-1-1. Main Input Screen - Single Case Mode

Specific Parameters

The following list describes the specific input parameters on the main input screen (indicated by ? in Figure 1-1-1) with corresponding units and range of data recognized by this application:

<u>Item</u>	<u>Symbol</u>	<u>Units</u>	<u>Data Range</u>
Elevation of observed wind	Z _{obs}	ft, m	1.0 to 5000.0
Observed wind speed	U _{obs}	ft/sec, mph, m/sec, knots	0.1 to 200.0
Air-sea temperature difference	ΔT	°C, °F	-100.0 to 100.0
Duration of observed wind	DurO	hr, min, sec	0.1 to 86400.0
Duration of final wind	DurF	hr, min, sec	0.1 to 86400.0
Latitude of wind observation	LAT	deg	0.0 to 180.0

Wind Observation Type

Select a *Wind Observation Type* by moving the cursor to the desired type and pressing . The options available are:

Location of ObservationWind Direction

Over water (shipboard)	
Over water (not shipboard)	
At shoreline (windward)	Offshore to onshore
At shoreline (leeward)	Onshore to offshore
Over land	
Geostrophic	

Wind Fetch Options

Select a *Wind Fetch Option* by moving the cursor to the desired option and pressing . The options available are:

- ° Open Water
- ° Restricted (Fetch)

Selecting either of these options will display *requestors* for further input. The format and data requirements of these requestors are described below.

Open-Water Wave Growth Equations Requestor

The Open-Water Wave Growth Equations *requestor* for the **Single Case Mode** is shown in Figure 1-1-2. It requests choosing between the deep- and shallow-water wave growth equations and values for the length and units of wind fetch.

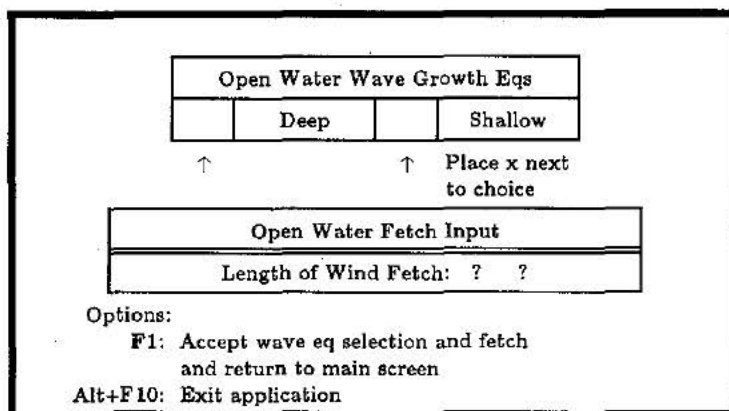

Figure 1-1-2. Open-Water Requestor - Single Case Mode

Select a *Wave Growth Equation* by moving the cursor to the desired type and pressing **[X]**. The options available are:

- Deep (deepwater wave growth relationships).
- Shallow (shallow-water wave growth relationships).

When the *Shallow* option is chosen, another *requestor* will appear on the screen asking for the value and units of the average depth of the fetch. See the section titled *Average Depth of Fetch Requestor* and Figure 1-1-3 for more details.

The following list summarizes the requested input (indicated by ? in Figure 1-1-2) for the Open-Water Wave Growth Equations *requestor*. The list identifies the specific input parameter, units, and range of data recognized by this application:

<u>Item</u>	<u>Symbol</u>	<u>Units</u>	<u>Data Range</u>
Length of wind fetch	F	ft, m, mi, km	0.0 to 9999.0

When all data on the Open-Water Wave Growth Equations *requestor* are correct, press one of the following keys to select the appropriate action:

- [F1]** Accept wave eq selection and fetch and return to main screen.
- [Alt] [F10]** Exit application.

Average Depth of Fetch Requestor

The Average Depth of Fetch *requestor* is shown in Figure 1-1-3 and appears when the shallow-water wave growth equations are selected.

Avg Depth of Fetch, d: ? ?

Options:
F1: Accept avg fetch depth data and
return to previous window
Alt+F10: Exit application

Figure 1-1-3. Average Depth of Fetch Requestor - Single Case Mode

The following list summarizes the requested input (indicated by ? in Figure 1-1-3) for this *requestor*. The list identifies the specific input parameter, units, and range of data recognized by this application:

<u>Item</u>	<u>Symbol</u>	<u>Units</u>	<u>Data Range</u>
Average depth of fetch	<i>d</i>	ft, m	0.1 to 10000.0

When the data for this *requestor* are correct, press one of the following keys to select the appropriate action:

F1 Accept avg fetch depth data and
return to previous window.

Alt F10 Exit application.

Restricted Fetch Requestor

The data requirements for the Restricted Fetch approach are substantially larger than the simpler Open-Water fetch approach. In addition to choosing between the deepwater and shallow-water wave growth equations, the wind approach direction must be specified as well as an accurate description of the geometry of the subject basin. Radial fetch lengths measured (clockwise from north) from the point of interest are used to describe the geometry of the basin. The

conventions and notations associated with data solicited by this group of *requestors* as well as the remainder of the data for the Fetch Geometry Data Entry Screen which follows are presented in Figure 1-1-4.

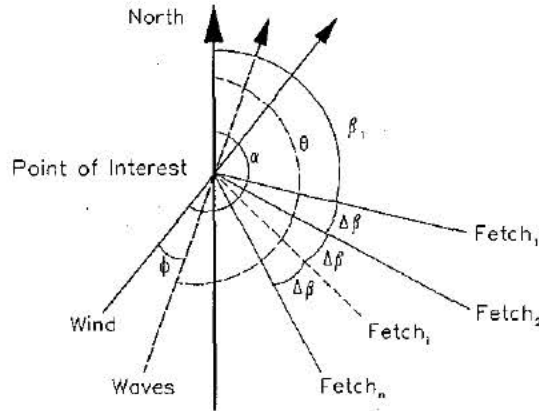

Figure 1-1-4. Restricted Fetch Conventions

The Restricted Fetch *requestor* for the **Single Case Mode** is shown in Figure 1-1-5. It requests a value for the wind approach direction and a choice between the deepwater and shallow-water wave growth equations. It also requests a choice between entering all of the fetch geometry interactively or reading the fetch geometry from a data file.

Restricted Fetch		
Wind Direction	α : ? deg	
↓	↓	
Wave Growth Equations	Fetch Geometry Input Options	
Deep	Keyboard	
Shallow	Data File	
↑	↑	
Place x on desired choice		

Options:

F1: Accept these data and return to main screen

Alt+F10: Exit Application

Figure 1-1-5. Restricted Fetch Requestor - Single Case Mode

The following list summarizes the requested input (indicated by ? in Figure 1-1-5) for the Restricted Fetch *requestor*. The list identifies the specific input parameter, units, and range of data recognized by this application:

<u>Item</u>	<u>Symbol</u>	<u>Units</u>	<u>Data Range</u>
Wind Direction	α	deg	0 to 360

Next, select a *Wave Growth Equation* by moving the cursor to the desired type and pressing \boxtimes . The options available are:

- Deep (deepwater wave growth relationships).
- Shallow (shallow-water wave growth relationships).

When the *Shallow* option is chosen, another *requestor* will appear on the screen requesting the average depth of the fetch. See the section titled *Average Depth of Fetch Requestor* and Figure 1-1-3 for data input details.

Finally, select a *Fetch Geometry Input Option* by moving the cursor to the desired option and pressing \boxtimes . The options available are:

- Keyboard (geometry keyed in now).
- Data File (geometry read from file).

Selecting either of these options will display *requestors* for further input. The format and data requirements of these requestors are described below.

Keyboard Data Entry Requestor

The Keyboard Data Entry *requestor* is shown in Figure 1-1-6.

Restricted Fetch Geometry Input	
Radial Angle Increment	$\Delta\beta$: ?
Dir of 1st Radial Fetch	β_1 : ?
No of Radial Fetches	Nfet: ?

Options:
 Alt+F1: Display radial fetch lengths
 F10: Return to previous window
 Alt+F10: Exit application

Figure 1-1-6. Keyboard Data Entry Requestor - Single Case Mode

The following list summarizes the requested input (indicated by ? in Figure 1-1-6) for the Restricted Fetch Keyboard Data Entry *requestor*. The list identifies the specific input parameter, units, and range of data recognized by this application:

<u>Item</u>	<u>Symbol</u>	<u>Units</u>	<u>Data Range</u>
Radial Angle Increment	$\Delta \beta$	deg	1.0 to 180.0
Dir of 1 st Radial Fetch	β_1	deg	0.0 to 360.0

NOTE: β_1 is measured clockwise from north.

No of Radial Fetches	Nfet		2 to 360
----------------------	------	--	----------

NOTE: The total angular coverage of the radials must not exceed 360 deg.

When the data on this *requestor* are correct, press one of the following keys to select the appropriate action:

- Alt F1 Display radial fetch lengths.
- F10 Return to previous window.
- Alt F10 Exit application.

When the Alt F1 option is selected, a Fetch Geometry Data Entry Screen (described below) will appear to allow input of fetch lengths.

Fetch Geometry Data Entry Screen

The majority of the data describing the restricted fetch geometry are collected on this data entry screen. A total of *Nfet* individual radial fetch lengths must be provided at their corresponding angles (measured clockwise from north and prescribed by $\beta_1, \Delta \beta$). The radial fetch index numbers and corresponding angles are displayed as an input aid on this screen. The units and allowed range of radial fetch values considered by this application are tabulated below:

<u>Item</u>	<u>Symbol</u>	<u>Units</u>	<u>Data Range</u>
Fetch Length		ft, m, mi, km	0.0 to 9999.0

Up to 20 values may be input and displayed on this screen. If more than 20 radial fetch values are specified ($N_{fet} > 20$), the screen will subsequently be re-invoked for the next 20 values and so on. When the data on this screen are correct, press one of the following keys to select the appropriate action:

F1 Accept data.

NOTE: The next 20 values may then be input when the screen is re-invoked in this fashion. If all (N_{fet}) values for radial fetch length have been specified, this action will signify acceptance of the data as entered and return to the main input screen (Figure 1-1-1).

Alt F10 Exit application.

Data File Entry Requestor

As an alternative to interactively keying in the restricted fetch geometry data, a data file containing the information may be specified. This requestor provides a mechanism for declaring the name of the data file which contains the restricted fetch geometry. The format of the Data File Entry *requestor* is shown in Figure 1-1-7.

Data File Name: WAWG.IN

Options:

Alt+F1: Read the data file now

F10: Return to previous window

Alt+F10: Exit Application

Figure 1-1-7. Data File Entry Requestor - Single Case Mode

Use this *requestor* to access and/or modify fetch geometry data saved in an external file. Typically this data file has been created with a text editor or saved as a trace file (default name TRACE.OUT) from a previous execution of this application. The format and contents of a trace file produced by this application match exactly the requirements of this input file. The default input file name is WAWG.IN, but other filenames (including pathname) are acceptable. For more information on files, see the section of this manual entitled, *General Instructions and Information*.

After specifying the name of the file, press one of the following keys to select the appropriate action:

(Alt) (F1) Read the data file now.

NOTE: Use this option to open and read the data file at this time. Upon successfully reading the file, the Fetch Geometry Data Entry Screen is displayed and shows the restricted fetch geometry read from the file. The data may then be edited or accepted using procedures described in the previous section.

(F10) Return to previous window.

NOTE: Use this option to return to the previous window without accepting any fetch geometry data.

(Alt) (F1) Exit application.

Finally, the application is executed with the selected options and data by pressing **(F1)** from the main input screen (Figure 1-1-1). Input and output data are displayed on the screen using the original units for related parameters. The one exception is the wave height (H_{m0}), which is reported in the final system of units. The following section entitled **Output** summarizes the parameters generated by this application.

After completion of the computations, press one of the following keys to select the appropriate action:

(F1) Solve a new case.

(F3) Send a summary of this case to the print file or device.

(F10) Exit this application and return to the Wave Prediction Application Menu.

Output

Results from this application are displayed on the main input screen in **Single Case Mode**. The report also includes the original input values. The following data are always reported:

<u>Item</u>	<u>Symbol</u>	<u>English Units</u>	<u>Metric Units</u>
Equivalent neutral wind speed	U_e	ft/sec, mph, knots	m/sec
Adjusted wind speed	U_a	ft/sec, mph, knots	m/sec
Wave height	H_{m0}	ft	m
Peak wave period	T_P	sec	sec

In addition to the above output, a message is provided indicating whether deep- or shallow-water equations were employed and whether the wave growth was ultimately determined by fetch-limited, duration-limited, or fully developed criteria.

If the restricted fetch approach was selected, the individual radial fetch data are not reported as output. However, the resultant maximized fetch as well as directional data for wind and wave growth are also displayed:

<u>Item</u>	<u>Symbol</u>	<u>English Units</u>	<u>Metric Units</u>
Fetch Length	F	ft, mi	m, km
Wind Direction	α	deg	deg
Wave Direction	θ	deg	deg

Multiple Case Mode

The bulleted items listed below provide instructions for accessing the application.

- Press **F2** on the Main Menu to select Multiple Case Mode.
- Fill in the highlighted input fields on the General Specifications screen (or leave the default values). Press **F1** when all data on this screen are correct.
- Press **F1** on the Functional Area Menu to select Wave Prediction.
- Press **F1** on the Wave Prediction Application Menu to select Windspeed Adjustment and Wave Growth.

Input

As in most ACES applications, the data requirements for the **Multiple Case Mode** are essentially the same as for **Single Case Mode**, but are organized in a different fashion. Data entry is accomplished through several screens and *requestors* which are described in the following sections.

Main Input Screen

The main input screen for the **Multiple Case Mode** is shown in Figure 1-1-8. It facilitates choosing a *Wind Observation Type* and *Wind Fetch Option* for all of the computations which follow.

	Type of Observation	Wind Direction
	Over Water (shipboard)	
	Over Water	
	Shoreline (windward)	Offshore->onshore
	Shoreline (leeward)	Onshore->offshore
	Over Land	
	Geostrophic	

Wind Fetch Options	
	Open Water
	Restricted

↑ Place x next to choice

Options:
F1: Proceed
F10: Exit Application

Figure 1-1-8. Main Input Screen - Multiple Case Mode

Wind Observation Type

Select a *Wind Observation Type* by moving the cursor to the desired type and pressing . The options available are:

<u>Location of Observation</u>	<u>Wind Direction</u>
Over water (shipboard)	
Over water (not shipboard)	
At shoreline (windward)	Offshore to onshore
At shoreline (leeward)	Onshore to offshore
Over Land	
Geostrophic	

Wind Fetch Options

Select a *Wind Fetch Option* by moving the cursor to the desired option and pressing . Two options are available:

- Open Water
- Restricted (Fetch)

Selecting either of these options will display appropriate *requestors* for further input. The format and data requirements of these *requestors* are described below.

Open-Water Wave Growth Equations Requestor

The Open-Water Wave Growth Equations *requestor* for the **Multiple Case Mode** is shown in Figure 1-1-9. It provides a mechanism for choosing between the deepwater and shallow-water wave growth equations.

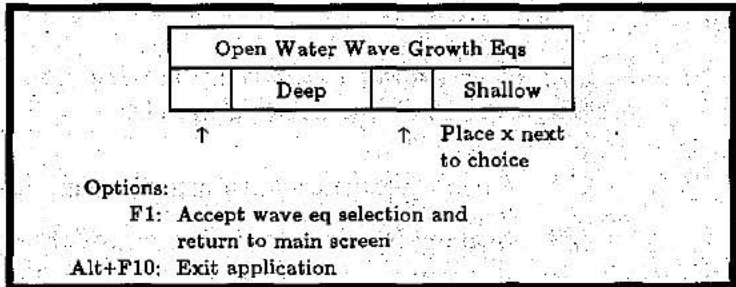

Figure 1-1-9. Open-Water Requestor - Multiple Case Mode

Select a wave growth equation by moving the cursor to the desired type and pressing . Two options are available:

- Deep (deepwater wave growth relationships).
- Shallow (shallow-water wave growth relationships).

After selecting a wave growth equation, press to return to the **Multiple Case Mode** main input screen (Figure 1-1-8) and press to bring up the *specific parameters* data entry screen.

Restricted Fetch Requestor

The *Restricted Fetch requestor* for the **Multiple Case Mode** is shown in Figure 1-1-10. It requests a choice between the deepwater and shallow-water wave growth equations and a choice for the preferred mode of entering data for the restricted fetch geometry.

↓ Wave Growth Equations	↓ Fetch Geometry Input Options
Deep	Keyboard
Shallow	Data File
↑	↑ Place x next to choice

Options:
F1: Accept these data and return to main screen
Alt+F10: Exit Application

Figure 1-1-10. Restricted Fetch Requestor - Multiple Case Mode

Select a *Wave Growth Equation* by moving the cursor to the desired type and pressing . Two options are available:

- Deep (deepwater wave growth relationships).
- Shallow (shallow-water wave growth relationships).

Finally, select a *Fetch Geometry Input Option* by moving the cursor to the desired option and pressing . The options available are:

- Keyboard (geometry keyed in now).
- Data File (geometry read from a file).

Selecting either of these options will display *requestors* for further input. The two corresponding *requestors* (Keyboard Data Entry and Data File Entry) have been described in the **Single Case Mode** portion of this document. Refer to those earlier sections for details.

After completing input on the *requestors*, return to the main input screen (Figure 1-1-8) and press to proceed to the *specific parameters* data entry screen and follow the steps outlined below for entering data on this screen.

Specific Parameters Data Entry Screen

1. Move the cursor to select a variable on this screen (the selected variable name blinks). The current set of values for the variable is displayed on the right portion of the screen. When all variable sets are correct, go to Step 3.
2. Enter a set of values for the subject variable by following one of the input methods:
 - a. Press to select random method. Enter up to 20 values constituting a set for this variable (one in each field) on the right side of the screen. The set of 20 values originally displayed (first execution) in these fields contains the "delimiting" value, which "delimits" or "ends" the set. The "delimiting" value is *not* included as a member in the set unless it is the sole member.
 - b. Press to select incremental method. Fill in the fields for minimum, maximum, and increment values for this variable on the right side of the screen. In this method, the members of the set include all values from the minimum to the maximum (both inclusive) at the specified increment.

The units field should also be specified for the variable regardless of input method. All members of a set of values for a subject variable are assigned the specified units. When all data are correct for the subject variable, press **F10** to return to Step 1. Errors are reported at the bottom of the screen and are corrected by pressing **F1** to allow respecification of the data for the subject variable.

3. Press **F1** to process the cases resulting from the combinations of the sets of data for all variables. The summary of each case will be sent to the print file or device. The screen will display the total number of cases to be processed as well as report progress. Errors are reported at the bottom of the screen and are corrected by pressing **F1** to allow respecification of variable sets.
4. Press one of the following keys to select the appropriate action:
 - F1** Return to Step 1 to specify new sets.
 - F10** Exit this application and return to the Wave Prediction Application Menu.

Output

Results from using this application in **Multiple Case Mode** are written to the Print File or Device. The format and contents reported are described in the Output section of the **Single Case Mode** portion of this document. Refer to that section for details. The primary difference is that the reported data are not displayed on the screen, but are always written to the Print File or Output Device.

EXAMPLE PROBLEMS**Example 1 - Offshore to Onshore Winds - Open-Water Fetch - Shallow-Water Wave Equations****Input****Main Input Screen**

<u>Item</u>	<u>Symbol</u>	<u>Value</u>	<u>Units</u>
Elevation of observed wind	Z_{obs}	25	ft
Observed wind speed	U_{obs}	45	mph
Air-sea temperature difference	ΔT	0	
Duration of observed wind	DUR	3	hr
Duration of final wind	DUR	3	hr
Latitude of wind observation	LAT	30	deg

Wind Observation Type -> Shore (windward)

Wind Fetch Option -> Open Water

Open-Water Wave Growth Equations Requestor

Open-Water Wave Growth Equation -> Shallow

Length of wind fetch	F	26	mi
----------------------	-----	----	----

Average Depth of Fetch Requestor

Average depth of fetch	d	13	ft
------------------------	-----	----	----

Output

<u>Item</u>	<u>Symbol</u>	<u>Value</u>	<u>Units</u>
Equivalent neutral wind speed	U_e	46.42	mph
Adjusted wind speed	U_a	67.92	mph
Wave height	H_{mo}	4.23	ft
Peak wave period	T_p	4.77	sec

Wave Growth: Shallow-water Fetch-limited

Example 2 - Shipboard Wind Observation - Open-Water Fetch - Deepwater Wave Equations

Input

Main Input Screen

<u>Item</u>	<u>Symbol</u>	<u>Value</u>	<u>Units</u>
Elevation of observed wind	Z_{obs}	60	ft
Observed wind speed	U_{obs}	30	knots
Air-sea temperature difference	ΔT	-5	deg C
Duration of observed wind	DUR	1	hr
Duration of final wind	DUR	3	hr
Latitude of wind observation	LAT	45	deg

Wind Observation Type -> Overwater (ship)

Wind Fetch Option -> Open Water

Open-Water Wave Growth Equations Requestor

Open-Water Wave Growth Equation -> Deep

Length of wind fetch	F	60	mi
----------------------	-----	----	----

Output

<u>Item</u>	<u>Symbol</u>	<u>Value</u>	<u>Units</u>
Equivalent neutral wind speed	U_e	27.71	knots
Adjusted wind speed	U_a	36.18	knots
Wave height	H_{mo}	4.74	ft
Peak wave period	T_p	4.65	sec

Wave Growth: Deepwater Duration-limited

Example 3 - Overwater Wind Observation - Deepwater Wave Equations - Restricted Fetch

Input

Main Input Screen

<u>Item</u>	<u>Symbol</u>	<u>Value</u>	<u>Units</u>
Elevation of observed wind	Z_{obs}	30	ft
Observed wind speed	U_{obs}	45	mph
Air-sea temperature difference	ΔT	-3	deg C
Duration of observed wind	DUR	5	hr
Duration of final wind	DUR	5	hr
Latitude of wind observation	LAT	47	deg
Wind Observation Type -> Overwater			
Wind Fetch Option -> Restricted			

Restricted Fetch Requestor

Wind Direction	α	125	deg
----------------	----------	-----	-----

NOTE: α is measured clockwise from north.

Open-Water Wave Growth Equation -> Deep
Fetch Geometry Input Options -> Keyboard

Keyboard Data Entry Requestor

See Figure 1-1-11 for illustration showing wind direction and fetch geometry for example problem 3.

Radial Angle Increment	$\Delta\beta$	12	deg
Dir of 1 st Radial Fetch	β_1	0	deg

NOTE: This direction angle is measured clockwise from north.

No of Radial Fetches	N_{fet}	14	
----------------------	-----------	----	--

Fetch Geometry Data Entry Screen

Units	miles	Radial Number	Fetch Angle	Fetch Length
		1	0.0	3.7
		2	12.0	12.3
		3	24.0	13.4
		4	36.0	12.2
		5	48.0	13.2
		6	60.0	36.0
		7	72.0	35.6
		8	84.0	28.7
		9	96.0	26.8
		10	108.0	13.0
		11	120.0	10.4
		12	132.0	10.1
		13	144.0	6.4
		14	156.0	5.7

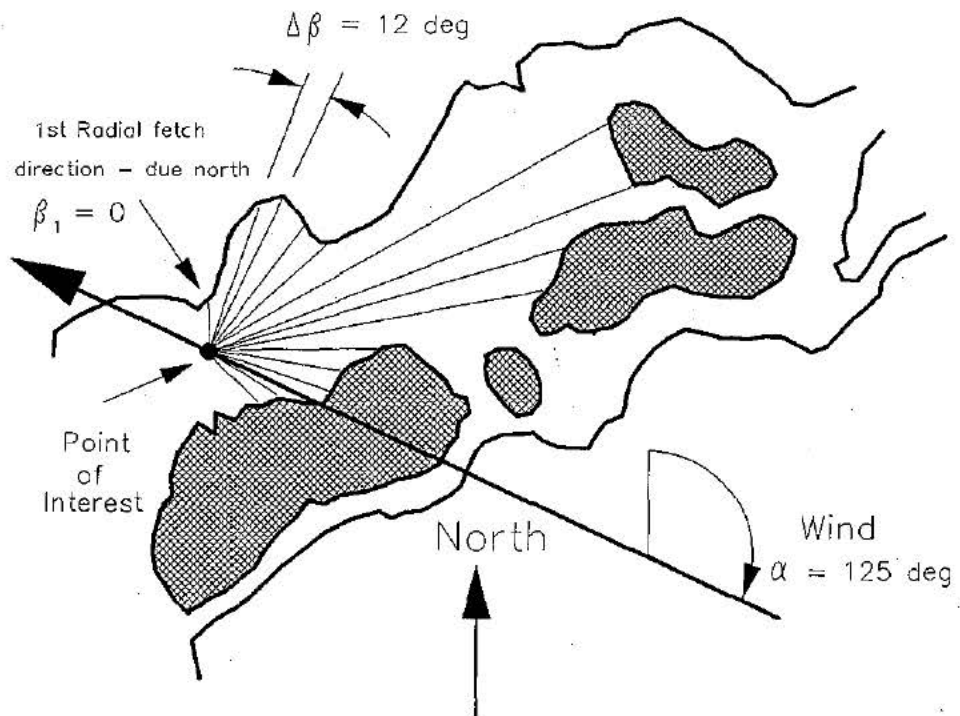

Figure 1-1-11. Restricted Fetch Geometry Illustration for Example 3

Output

<u>Item</u>	<u>Symbol</u>	<u>Value</u>	<u>Units</u>
Wind Fetch	F	26.61	mi
Wind Direction		125.00	deg
Equivalent neutral wind speed	U_e	44.00	mph
Adjusted wind speed	U_a	63.27	mph
Mean Wave Direction		93.00	deg
Wave height	H_{mo}	7.80	ft
Peak wave period	T_p	5.74	sec
Wave Growth: Deepwater Fetch-limited			

REFERENCES AND BIBLIOGRAPHY

- Bretschneider, C. L., and Reid, R. O. 1954. "Modification of Wave Height Due to Bottom Friction, Perlocation and Refraction," Technical Report 50-1, The Agricultural and Mechanical College of Texas, College Station, TX.
- Cardone, V. J. 1969. "Specification of the Wind Distribution in the Marine Boundary Layer for Wave Forecasting," TR-69-1, Geophysical Sciences Laboratory, Department of Meteorology and Oceanography, School of Engineering and Science, New York University, New York.
- Cardone, V. J., et al. 1976. "Hindcasting the Directional Spectra of Hurricane-Generated Waves," *Journal of Petroleum Technology*, American Institute of Mining and Metallurgical Engineers, No. 261, pp. 385-394.
- Donelan, M.A. 1980. "Similarity Theory Applied to the Forecasting of Wave Heights, Periods, and Directions," *Proceedings of the Canadian Coastal Conference*, National Research Council, Canada, pp. 46-61.
- Garratt, J. R., Jr. 1977. "Review of Drag Coefficients over Oceans and Continents," *Monthly Weather Review*, Vol. 105, pp. 915-929.
- Hasselmann, K., Barnett, T. P., Bonws, E., Carlson H., Cartwright, D. C., Enke, K., Ewing, J., Gienapp, H., Hasselmann, D. E., Kruseman, P., Meerburg, A., Muller, P., Olbers, D. J., Richter, K., Sell, W., and Walden, H. 1973. "Measurements of Wind-Wave Growth and Swell Decay During the Joint North Sea Wave Project (JONSWAP)," Deutches Hydrographisches Institut, Hamburg, 95 pp.
- Hasselmann, K., Ross, D. B., Muller, P., and Sell, W. 1976. "A Parametric Prediction Model," *Journal of Physical Oceanography*, Vol. 6, pp. 200-228.
- Holton, J. R. 1979. *An Introduction to Dynamic Meteorology*, Academic Press, Inc., New York, pp. 102-118.
- Lumley, J. L., and Panofsky, H. A. 1964. *The Structure of Atmospheric Turbulence*, Wiley, New York.

- Mitsuyasu, H. 1968. "On the Growth of the Spectrum of Wind-Generated Waves (I)," Reports of the Research Institute of Applied Mechanics, Kyushu University, Fukuoka, Japan, Vol. 16, No. 55, pp. 459-482.
- Resio, D. T. 1981. "The Estimation of Wind Wave Generation in a Discrete Model," *Journal of Physical Oceanography*, Vol. 11, pp. 510-525.
- Resio, D. T. 1987. "Shallow Water Waves. I: Theory," *Journal of Waterway, Port, Coastal and Ocean Engineering*, American Society of Civil Engineers, Vol. 113, No. 3, pp. 264-281.
- Resio, D. T., Vincent, C. L., and Corson, W. D. 1982. "Objective Specification of Atlantic Ocean Wind Fields from Historical Data," Wave Information Study Report No. 4, US Army Engineer Waterways Experiment Station, Vicksburg, MS.
- Shore Protection Manual*. 1984. 4th ed., 2 Vols., US Army Engineer Waterways Experiment Station, Coastal Engineering Research Center, US Government Printing Office, Washington, DC, Chapter 3, pp. 24-66.
- Smith, J.M. 1991. Wind-Wave Generation on Restricted Fetches," Miscellaneous Paper CERC-91-2, US Army Engineer Waterways Experiment Station, Vicksburg, MS.
- Vincent, C. L. 1984. "Deepwater Wind Wave Growth with Fetch and Duration," Miscellaneous Paper CERC-84-13, US Army Engineer Waterways Experiment Station, Vicksburg, MS.

BETA-RAYLEIGH DISTRIBUTION

TABLE OF CONTENTS

Description	1-2-1
Input	1-2-1
Output	1-2-1
Screen Output	1-2-1
Plot Output File 1	1-2-2
Screen Plot	1-2-2
Procedure	1-2-2
Single Case Mode	1-2-2
Multiple Case Mode	1-2-3
Example Problem	1-2-4
Input	1-2-4
Output	1-2-5
Screen Output	1-2-5
Plot Output File 1	1-2-5
Screen Plot	1-2-6
References and Bibliography	1-2-7

BETA-RAYLEIGH DISTRIBUTION

DESCRIPTION

This application provides a statistical representation for a shallow-water wave height distribution. The Beta-Rayleigh distribution is expressed in familiar wave parameters: H_{mo} (energy-based wave height), T_p (peak spectral wave period), and d (water depth). After constructing the distribution, other statistically based wave height estimates such as H_{rms} , H_{mean} , $H_{1/10}$ can be easily computed. The Beta-Rayleigh distribution features a finite upper bound corresponding to the breaking wave height, and the expression collapses to the Rayleigh distribution in the deepwater limit. The methodology for this portion of the application is taken exclusively from Hughes and Borgman (1986).

INPUT

All data input for this application is done on one screen. The following list describes the necessary input parameters with their corresponding units and range of data recognized by this application:

<u>Item</u>	<u>Symbol</u>	<u>Units</u>	<u>Data Range</u>	
Wave height	H_{mo}	ft, m	0.1	to 60.0
Wave period	T_p	sec	2.0	to 30.0
Water depth	d	ft, m	0.1	to 3000.0

OUTPUT

Results from this application are displayed on one screen. In addition, there is an option (available in the Single Case Mode only) to send data to plot output file 1 (default name PLOTDAT1.OUT). This application also generates one screen plot. Each of these outputs is described below.

Screen Output

Results from this application are displayed on one screen. Those data include the original input values (in final units) and the following parameters:

<u>Item</u>	<u>Symbol</u>	<u>English Units</u>	<u>Metric Units</u>
Root-mean-squared (rms) wave height	H_{rms}	ft	m
Median wave height	H_{med}	ft	m

$H_{1/3}$	ft	m
$H_{1/10}$	ft	m
$H_{1/100}$	ft	m

NOTE: The Beta-Rayleigh distribution will revert to the Rayleigh distribution when $d/gT^2 \geq 0.01$. A message will appear at the bottom of the screen when this occurs.

Plot Output File 1

Plot output file 1 contains the Beta-Rayleigh or Rayleigh probability density function (pdf) and is written in the following format (see Table 1-2-1 in the example problem):

Field	Columns	Format	Data
1	8-10	I3	Point counter
2	14-23	F10.3	Wave height
3	33-42	F10.3	Beta-Rayleigh or Rayleigh probability density

Screen Plot

This application generates one plot which contains seven curves. The first curve (solid line) is the Beta-Rayleigh or Rayleigh prediction. The remaining curves (represented by individual symbols) are various wave-height probabilities (see Figure 1-2-1 in the example problem).

PROCEDURE

The bulleted items in the following lists indicate potentially optional instruction steps. Any application in ACES may be executed in a given session without quitting the program. The bulleted items provide instructions for accessing the application from various menu areas of the ACES program. Ignore bulleted instruction steps that are not applicable.

Single Case Mode

- ° Press **F1** on the Main Menu to select Single Case Mode.
- ° Fill in the highlighted input fields on the General Specifications screen (or leave the default values). Press **F1** when all data on this screen are correct.

- Press **F1** on the Functional Area Menu to select Wave Prediction.
 - Press **F2** on the Wave Prediction Menu to select Beta-Rayleigh Distribution.
1. Fill in the highlighted input fields on the Beta-Rayleigh Distribution screen. Respond to any corrective instructions appearing at the bottom of the screen. Press **F1** when all data on this screen are correct.
 2. All input and output data are displayed on the screen in the final system of units.
 3. Press one of the following keys to select the appropriate action:
 - F1** Return to Step 1 for a new case.
 - F2** Plot the data.
 - F3** Send a summary of this case to the print file or device.
 - F4** Generate a file containing the plot data (Plot Output File 1).
 - F10** Exit this application and return to the Wave Prediction Menu.

Multiple Case Mode

- Press **F2** on the Main Menu to select Multi Case Mode.
 - Fill in the highlighted input fields on the General Specifications screen (or leave the default values). Press **F1** when all data on this screen are correct.
 - Press **F1** on the Functional Area Menu to select Wave Prediction.
 - Press **F2** on the Wave Prediction Menu to select Beta-Rayleigh Distribution.
1. Move the cursor to select a variable on the Beta-Rayleigh Distribution screen (the selected variable name blinks). The current set of values for the variable is displayed on the right portion of the screen. When all variable sets are correct, go to Step 3.
 2. Enter a set of values for the subject variable by following one of the input methods:
 - a. Press **R** to select random method. Enter up to 20 values constituting a set for this variable (one in each field) on the right side of the screen. The set of 20 values originally displayed (first execution) in these fields contains the "delimiting" value, which "delimits" or "ends" the set. The "delimiting" value is *not* included as a member in the set unless it is the sole member.

- b. Press **I** to select incremental method. Fill in the fields for minimum, maximum, and increment values for this variable on the right side of the screen. In this method, the members of the set include all values from the minimum to the maximum (both inclusive) at the specified increment.

The units field should also be specified for the variable regardless of input method. All members of a set of values for a subject variable are assigned the specified units. When all data are correct for the subject variable, press **F10** to return to Step 1. Errors are reported at the bottom of the screen and are corrected by pressing **F1** to allow respecification of the data for the subject variable.

3. Press **F1** to process the cases resulting from the combinations of the sets of data for all variables. The summary of each case will be sent to the print file or device. The screen will display the total number of cases to be processed as well as report progress. Errors are reported at the bottom of the screen and are corrected by pressing **F1** to allow respecification of variable sets.
4. Press one of the following keys to select the appropriate action:
- F1** Return to Step 1 to specify new sets.
 - F10** Exit this application and return to the Wave Prediction Menu.

NOTE: Multiple Case Mode does not generate any plot output files or plots.

EXAMPLE PROBLEM

Input

All data input for this application is done on one screen. The values and corresponding units selected for this example problem are shown below.

<u>Item</u>	<u>Symbol</u>	<u>Value</u>	<u>Units</u>
Wave height	H_{mo}	5.00	ft
Wave period	T_p	6.30	sec
Water depth	d	10.20	ft

Output

Results from this application are displayed on one screen and, if requested, written to plot output file 1 (default name **PLOTDAT1.OUT**). In addition, one plot is generated. Each of these outputs for the example problem is presented below.

Screen Output

Results from this application are displayed on one screen. Those data include the original input values and the following parameters:

<u>Item</u>	<u>Symbol</u>	<u>Value</u>	<u>Units</u>
Wave heights	H_{rms}	3.72	ft
	H_{med}	3.26	ft
	$H_{1/3}$	5.18	ft
	$H_{1/10}$	6.55	ft
	$H_{1/100}$	7.48	ft

Plot Output File 1

Table 1-2-1 below is a partial listing of plot output file 1 (default name **PLOTDAT1.OUT**) generated by this application for the example problem.

Table 1-2-1
Partial Listing of Plot Output File 1 for Example Problem

Counter	Wave height	Probability density
1	0.00000	0.00000
2	0.10200	0.03707
3	0.20400	0.07630
4	0.30600	0.11618
5	0.40800	0.15624
6	0.51000	0.19621
7	0.61200	0.23586
8	0.71400	0.27499
9	0.81600	0.31342
10	0.91800	0.35100
11	1.02000	0.38756
12	1.12200	0.42297
13	1.22400	0.45710
↓	↓	↓

(Table 1-2-1 Continued on the Next Page)

(Table 1-2-1 Concluded)

89	8.97600	0.00085
90	9.07800	0.00054
91	9.18000	0.00033
92	9.28200	0.00019
93	9.38400	0.00010
94	9.48600	0.00005
95	9.58800	0.00002
96	9.69000	0.00001
97	9.79200	0.00000
98	9.89400	0.00000
99	9.99600	0.00000
100	10.09800	0.00000
101	10.20000	0.00000

Screen Plot

This application generates one plot. The plot may be accessed by selecting the **Plot Data** option (**F2**) from the **Options** menu on the data output screen. The plot generated is shown in Figure 1-2-1 below. The first curve (solid line) is the Beta-Rayleigh or Rayleigh prediction. The remaining curves (represented by single symbols) are various wave-height probabilities. (This figure has been slightly altered from its actual appearance on screen to allow the wave height probability symbols to be clearly visible.)

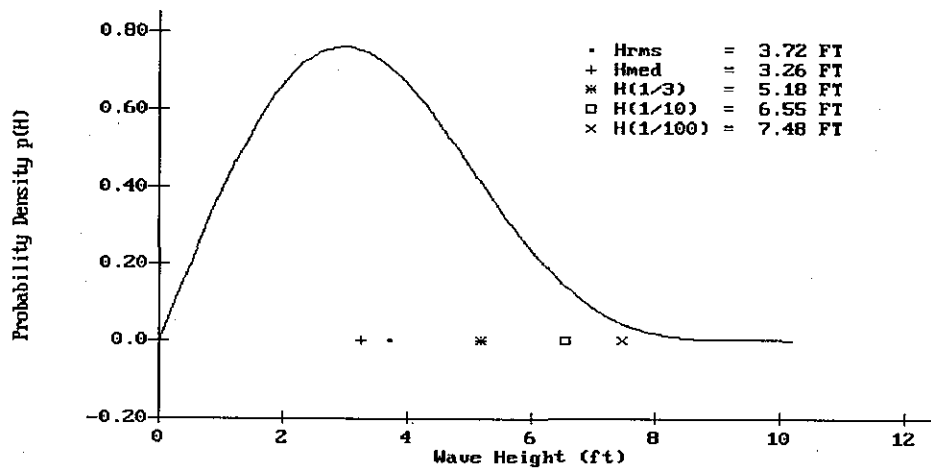

Figure 1-2-1. Beta-Rayleigh Predictions for Example Problem

REFERENCES AND BIBLIOGRAPHY

- Battjes, J. A. 1972. "Set-Up Due to Irregular Waves," *Proceedings of the 13th International Conference on Coastal Engineering*, American Society of Civil Engineers, pp. 1993-2004.
- Collins, J. I. 1970. "Probabilities of Breaking Wave Characteristics," *Proceedings of the 12th International Conference on Coastal Engineering*, American Society of Civil Engineers, pp. 399-412.
- Dattatri, J. 1973. "Waves off Mangalore Harbor - West Coast of India," *Journal of the Waterway, Port, Coastal, and Ocean Engineering Division*, American Society of Civil Engineers, Vol. 99, No. 1, pp. 39-58.
- Earle, M. D. 1975. "Extreme Wave Conditions During Hurricane Camille," *Journal of Geophysical Research*, Vol. 80, No. 3, pp. 377-379.
- Ebersole, B. A., and Hughes, S. A. 1987. "DUCK85 Photopole Experiment," Miscellaneous Paper CERC-87-18, US Army Engineer Waterways Experiment Station, Vicksburg, MS.
- Forristall, G. Z. 1978. "On the Statistical Distribution of Wave Heights in a Storm," *Journal of Geophysical Research*, Vol. 83, No. C5, pp. 2353-2358.
- Goda, Y. 1975. "Irregular Wave Deformation in the Surf Zone," *Coastal Engineering in Japan*, Vol. 18, pp. 13-26.
- Hughes, S. A., and Borgman, L. E. 1987. "Beta-Rayleigh Distribution for Shallow Water Wave Heights," *Proceedings of the American Society of Civil Engineers Specialty Conference on Coastal Hydrodynamics*, American Society of Civil Engineers, pp. 17-31.
- Kuo, C. T., and Kuo, S. T. 1974. "Effect of Wave Breaking on Statistical Distribution of Wave Heights," *Proceedings of Civil Engineering in the Oceans, III*, American Society of Civil Engineers, pp. 1211-1231.
- Longuet-Higgins, M. S. 1952. "On the Statistical Distribution of the Heights of Sea Waves", *Journal of Marine Research*, Vol. 11, No. 3, pp. 245-266.
- Ochi, M. K., Malakar, S. B., and Wang, W. C. 1982. "Statistical Analysis of Coastal Waves Observed During the ARSLOE Project," UFL/COEL/TR-045, Coastal and Oceanographic Engineering Department, University of Florida, Gainesville, FL.
- Scheffner, N. W. 1986. "Biperiodic Waves in Shallow Water," *Proceedings of the 20th International Conference on Coastal Engineering*, American Society of Civil Engineers, pp. 724-736.
- Shore Protection Manual*. 1984. 4th ed., 2 Vols., US Army Engineer Waterways Experiment Station, Coastal Engineering Research Center, US Government Printing Office, Washington, DC.
- Thompson, E. F. 1974. "Results from the CERC Wave Measurement Program," *Proceedings of the International Symposium on Ocean Wave Measurement and Analysis*, American Society of Civil Engineers, pp. 836-855.
- Thompson, E. F., and Vincent, C. L. 1985. "Significant Wave Height for Shallow Water Design," *Journal of the Waterway, Port, Coastal, and Ocean Engineering Division*, American Society of Civil Engineers, Vol. 111, No. 5, pp. 828-842.

EXTREMAL SIGNIFICANT WAVE HEIGHT ANALYSIS

TABLE OF CONTENTS

Description	1-3-1
Input	1-3-1
Output	1-3-1
Plot Output File 1	1-3-2
Procedure	1-3-2
Single Case Mode	1-3-2
Data Entry Options Menu	1-3-2
Initial Case Data Entry	1-3-2
Edit Case in External File: EXTREMAL.IN	1-3-3
Activity Menu	1-3-3
Begin Computations	1-3-3
Significant Wave Height Data Entry	1-3-3
Confidence Interval Limits Entry	1-3-4
Review Output Screens	1-3-4
Plot Output Data	1-3-5
Example Problem	1-3-6
Input	1-3-6
Output	1-3-7
Screen Output	1-3-7
Plot Output File 1	1-3-9
Screen Plots	1-3-15
References and Bibliography	1-3-17

EXTREMAL SIGNIFICANT WAVE HEIGHT ANALYSIS

DESCRIPTION

This application provides significant wave height estimates for various return periods. Confidence intervals are also provided. The approach developed by Goda (1988) is used to fit five candidate probability distributions to an input array of extreme significant wave heights. Candidate distribution functions are Fisher-Tippett Type I and Weibull with exponents ranging from 0.75 to 2.0. Goodness-of-fit information is provided for identifying the distributions which best match the input data.

INPUT

The input requirements of this application consist of the following information:

- Estimated total number of events (N_T) from the population during the length of record.
- Length of the record in years (K).
- Water depth to check for depth-limited wave heights.
- Significant wave heights (H_s) from long-term data source of measurements, hindcasts, or observations.
- Confidence level for calculating a confidence interval.

Data input to this application is accomplished through numerous input screens or through data saved in an external file. Detailed lists of the screens and input parameters are presented in the *Procedure* section of this document.

OUTPUT

Results from this application are displayed on three screens and written to plot output file 1 (default name PLOTDAT1.OUT). This application also generates five plots. The three output screens and five plots are described in the *Procedure* section of this document. The content of the plot output file is described below (refer to the **Example Problem** section for a paradigm). Equation numbers given below and referenced in the plot output file refer to equations in Section 1-3 of the ACES *Technical Reference*, titled *Extremal Significant Wave Height Analysis*.

Plot Output File 1

This file contains, for each of the five distributions, tabular summaries of:

- Correlation and the sum of the squares of the residuals.
- Estimates of the scale and location parameters from linear regression analysis.
- The probability assigned to each significant wave height (Equation 3).
- A reduced variate (Equation 5).
- An ordered variate (Equation 4).
- Difference between the significant wave height and the ordered variate.
- Expected extreme wave height for a given return period (Equation 6).
- Absolute magnitude of the standard deviation of significant wave height (Equation 10).

PROCEDURE

This application provides only a Single Case Mode. The Multiple Case Mode is not available. The Single Case Mode requires interaction with the application and provides two options of interactive participation. The first option allows entering new data sets, and the second option allows the editing of existing data files.

Single Case Mode

- Press **F1** on the Main Menu to select Single Case Mode.
- Fill in the highlighted input fields on the General Specifications screen (or leave the default values). Press **F1** when all data on this screen are correct.
- Press **F1** on the Functional Area Menu to select Wave Prediction.
- Press **F3** on the Wave Prediction Menu to select Extremal Significant Wave Height Analysis.

Data Entry Options Menu

This menu provides two options of interactive participation with the application.

F1 Initial Case Data Entry

Use this option to enter an initial (new) set of data. These data will be written to the *Trace Output* file (default name **TRACE.OUT**) and become available for subsequent editing and use.

(Alt) (F1) Edit Case in External File: EXTREMAL.IN

Use this option to access and modify data saved in an external file. This external data file is created by saving (or copying) a *trace file* from a previous execution of this application. The format and contents of the *trace file* for this application match exactly the requirements of this input file. The default input filename is **EXTREMAL.IN**, but other filenames (including pathname) are acceptable. After entering the filename, press **(ENTER)** to accept this file. *For more information on files, see the section of this manual entitled, "General Instructions and Information."*

Activity Menu

The Activity Menu is a point from which all options for Single Case data entry, modification, and execution are accessible. The options are:

- (F1)** Begin Computations.
- (F2)** Significant Wave Height Entry.
- (F3)** Confidence Interval Limits Entry.
- (F4)** Review Output Screens.
- (F5)** Plot Output Data.
- (F10)** Exit Menu.

Each option and the required data are described below.

(F1) Begin Computations

Use this option only after all data have been entered.

(F2) Significant Wave Height Data Entry

This screen provides for input of general parameters required to run the application. Values for all parameters listed are required.

<u>Item</u>	<u>Units</u>	<u>Data Range</u>	
Units	ft,m		
N _T		0	to 10000.0
Period (yr) K	years	0	to 999.9
Water Depth	ft,m	0	to 1000.0
Significant Wave Height for Each Storm	ft,m	0	to 100.0

NOTE: There is space provided on this screen to enter a title or description (optional) to identify where the significant wave data is coming from. This title will appear in the plot output file for reference.

NOTE: If there are more than 50 significant heights to be entered, press **(F1)** to access subsequent screens for entering the remaining values. Each screen will allow input of 50 values. The application will allow for a maximum of 200 values to be entered. After completing data entry on this screen, press **(F10)** to return to the Activity Menu.

(F3) Confidence Interval Limits Entry

This screen provides for selecting a particular *Confidence Interval*. Use the arrow keys to move the blinking cursor to the desired *Confidence Interval* and press **(F1)** to select it. The choices are:

- 80% Confidence Interval
- 85% Confidence Interval
- 90% Confidence Interval
- 95% Confidence Interval
- 99% Confidence Interval

(F4) Review Output Screens

This option allows for viewing the output of this application, which appears on three screens. The three screens are described below:

- The first screen is a table of extremal significant wave heights for different return periods for the five distribution functions. Also included in the table are two statistics (correlation and sum of the squares of the residuals) to assist in selecting the best fit distribution function.
 - The second screen is a table of confidence intervals for different return periods for the five distribution functions.
 - The third screen is a table of percent chance that the significant wave height will equal or exceed the return-period significant height during the period of concern.
-

[F5] Plot Output Data

This application generates five plots. The plots may be accessed from the **EXTREMAL WAVE HEIGHT PLOT MENU**, which appears when the **Plot Output Data** option is requested. To access a plot, move the cursor (using the arrow keys) to the desired plot and press **[F1]**. (Appendix C describes options to customize plots.) Available plots are:

- Fisher-Tippett (FT-I) (see Figure 1-3-1)
- Weibull Dist (k=0.75) (see Figure 1-3-2)
- Weibull Dist (k=1.00) (see Figure 1-3-3)
- Weibull Dist (k=1.40) (see Figure 1-3-4)
- Weibull Dist (k=2.00) (see Figure 1-3-5)
- **ALL PLOTS**

NOTE: This option will make all the plots available for viewing. Use the **NEXT** option of the graphics package (Appendix C) to view each plot successively.

- **EXIT MENU**

Each plot contains four curves:

- Expected extreme wave heights for given return periods.
- Candidate probability distribution.
- Upper confidence limit.
- Lower confidence limit.

EXAMPLE PROBLEM**Input**

The input for this example problem has been saved in an example file called **EXTDELFT.IN**. Refer to the section titled *Procedure* for instructions to invoke and run this data set.

F2 *Significant Wave Height Data Entry*

<u>Item</u>	<u>Value</u>
Units	meters
N_T	20
Period (yr) K	20
Water Depth	500
Significant Wave Height for Each Storm	
1	9.32
2	8.11
3	7.19
4	7.06
5	6.37
6	6.15
7	6.03
8	5.72
9	4.92
10	4.90
11	4.78
12	4.67
13	4.64
14	4.19
15	3.06

F3 *Confidence Interval Limits Entry*

90% Confidence Interval

Output

Results from this application are displayed on three screens and written to plot output file 1 (default name **PLOTDAT1.OUT**). In addition five plots are generated. Each of these outputs is described below.

Screen Output

The first screen is a table of extremal significant wave heights for different return periods for the five distribution functions. Also included in the table are two statistics (correlation and sum of the squares of the residuals) to assist in selecting the best fit distribution function.

First Screen					
N = 15 NU = 0.75 NT = 20 K = 20 yr LAMBDA = 1.00	FT-I	Weibull Distribution			
		k=0.75	k=1.00	k=1.40	k=2.00
Correlation	0.9813	0.9414	0.9674	0.9818	0.9866
Sum Square of Residuals	0.1601	0.7816	0.3568	0.2201	0.1034
Return Period (Yr)	H _s (ft)	H _s (ft)	H _s (ft)	H _s (ft)	H _s (ft)
2	15.94	15.96	15.79	15.77	15.86
5	21.50	20.18	20.91	21.56	22.02
10	25.18	24.00	24.79	25.29	25.53
25	29.84	29.66	29.91	29.76	29.44
50	33.29	34.33	33.79	32.90	32.03
100	36.72	39.29	37.66	35.89	34.40

The second screen is a table of confidence intervals for different return periods for the five distribution functions.

Second Screen					
90% Confidence Interval (Lower Bound - Upper Bound) UNITS (ft)					
Return Period	FT-I	Weibull Distribution			
		k=0.75	k=1.00	k=1.40	k=2.00
5	17.7 - 25.3	15.1 - 25.3	16.4 - 25.4	17.2 - 25.9	17.8 - 26.2
10	19.7 - 30.7	15.8 - 32.2	17.9 - 31.7	19.2 - 31.3	20.1 - 31.0
25	22.0 - 37.7	16.5 - 42.8	19.7 - 40.1	21.6 - 38.0	22.5 - 36.4
50	23.6 - 43.0	17.1 - 51.5	21.1 - 46.5	23.2 - 42.6	24.1 - 40.0
100	25.2 - 48.2	17.8 - 60.8	22.4 - 52.9	24.7 - 47.1	25.5 - 43.3

The third screen is a table of percent chance that the significant wave height will equal or exceed the return-period significant height during the period of concern.

Third Screen						
Percent Chance for Significant Height Equaling or Exceeding Return Period H_s						
Return Period	Period of Concern (Yr)					
	2	5	10	25	50	100
2	75	97	100	100	100	100
5	36	67	89	100	100	100
10	19	41	65	93	99	100
25	8	18	34	64	87	98
50	4	10	18	40	64	87
100	2	5	10	22	39	63

Plot Output File 1

This file contains, for each of the five distributions, tabular summaries of:

- Correlation and the sum of the squares of the residuals.
- Estimates of the scale and location parameters from linear regression analysis.
- The probability assigned to each significant wave height (Equation 3).
- A reduced variate (Equation 5).
- An ordered variate (Equation 4).
- Difference between the significant wave height and the ordered variate.
- Expected extreme wave height for a given return period (Equation 6).
- Absolute magnitude of the standard deviation of significant wave height (Equation 10).

Equation numbers refer to equations in Section 1-3 of the ACES *Technical Reference*, titled *Extremal Significant Wave Height Analysis*.

Table 1-3-1 is a complete listing of plot output file 1 (default name **PLOTDAT1.OUT**).

Table 1-3-1
Listing of Plot Output File 1 for Example Problem

**EXTREMAL SIGNIFICANT WAVE HEIGHT ANALYSIS
DELFT Data**

N = 15 STORMS

NT = 20 STORMS

NU = 0.75

K = 20.00 YEARS

LAMBDA = 1.00 STORMS PER YEAR

MEAN OF SAMPLE DATA = 19.053 FEET

STANDARD DEVIATION OF SAMPLE = 5.341 FEET

(Table 1-3-1 Continued on the Next Page)

(Table 1-3-1 Continued)

FISHER-TIPPETT TYPE I (FT-I) DISTRIBUTION

$F(H_s) = \text{EXP}(-\text{EXP}(-(H_s-B)/A))$ - Equation 1

A = 4.910 FEET

B = 14.136 FEET

CORRELATION = 0.9813

SUM SQUARE OF RESIDUALS = 0.1601 FEET

RANK	Hsm (Ft)	F(Hs<=Hsm) Eq. 3	Ym Eq. 5	A*Ym+B (Ft) Eq. 4	Hsm-(A*Ym+B) (Ft)
1	30.58	0.9722	3.567	31.6513	-1.0739
2	26.61	0.9225	2.517	26.4935	0.1141
3	23.59	0.8728	1.994	23.9281	-0.3388
4	23.16	0.8231	1.636	22.1690	0.9937
5	20.90	0.7734	1.359	20.8064	0.0926
6	20.18	0.7237	1.129	19.6777	0.4995
7	19.78	0.6740	0.930	18.7014	1.0821
8	18.77	0.6243	0.752	17.8303	0.9361
9	16.14	0.5746	0.590	17.0340	-0.8922
10	16.08	0.5249	0.439	16.2914	-0.2153
11	15.68	0.4751	0.296	15.5868	0.0956
12	15.32	0.4254	0.157	14.9071	0.4145
13	15.22	0.3757	0.021	14.2407	0.9824
14	13.75	0.3260	-0.114	13.5761	0.1706
15	10.04	0.2763	-0.252	12.9003	-2.8609

RETURN PERIOD TABLE with 90% CONFIDENCE INTERVAL

RETURN PERIOD (Yr)	Hs (Ft) Eq. 6	SIGR (Ft) Eq. 10	Hs-1.28*SIGR (Ft)	Hs+1.28*SIGR (Ft)
2.00	15.94	1.38	13.66	18.21
5.00	21.50	2.27	17.75	25.25
10.00	25.18	3.32	19.71	30.66
25.00	29.84	4.76	21.99	37.69
50.00	33.29	5.86	23.63	42.96
100.00	36.72	6.96	25.24	48.20

(Table 1-3-1 Continued on the Next Page)

(Table 1-3-1 Continued)

WEIBULL DISTRIBUTION $k = 0.75$

$$F(H_s) = 1 - \text{EXP}(-((H_s - B)/A)^{k}) \text{ Equation 2}$$

$$A = 3.310 \text{ FEET}$$

$$B = 13.933 \text{ FEET}$$

$$\text{CORRELATION} = 0.9414$$

$$\text{SUM SQUARE OF RESIDUALS} = 0.7816 \text{ FEET}$$

RANK	Hsm (Ft)	F(Hs<=Hsm) Eq. 3	Ym Eq. 5	A*Ym+B (Ft) Eq. 4	Hsm-(A*Ym+B) (Ft)
1	30.58	0.9761	5.796	33.1177	-2.5403
2	26.61	0.9273	3.614	25.8942	0.7134
3	23.59	0.8784	2.701	22.8739	0.7153
4	23.16	0.8296	2.140	21.0156	2.1471
5	20.90	0.7807	1.744	19.7032	1.1957
6	20.18	0.7318	1.442	18.7065	1.4707
7	19.78	0.6830	1.203	17.9146	1.8688
8	18.77	0.6341	1.007	17.2663	1.5001
9	16.14	0.5852	0.843	16.7240	-0.5823
10	16.08	0.5364	0.704	16.2632	-0.1871
11	15.68	0.4875	0.585	15.8672	-0.1848
12	15.32	0.4387	0.481	15.5241	-0.2025
13	15.22	0.3898	0.390	15.2250	-0.0019
14	13.75	0.3409	0.311	14.9635	-1.2168
15	10.04	0.2921	0.242	14.7347	-4.6954

RETURN PERIOD TABLE with 90% CONFIDENCE INTERVAL

RETURN PERIOD (Yr)	Hs (Ft) Eq. 6	SIGR (Ft) Eq. 10	Hs-1.28*SIGR (Ft)	Hs+1.28*SIGR (Ft)
2.00	15.96	1.47	13.54	18.38
5.00	20.18	3.08	15.09	25.26
10.00	24.00	4.99	15.76	32.23
25.00	29.66	7.95	16.54	42.78
50.00	34.33	10.42	17.14	51.53
100.00	39.29	13.05	17.75	60.83

(Table 1-3-1 Continued on the Next Page)

(Table 1-3-1 Continued)

WEIBULL DISTRIBUTION $k = 1.00$

$F(H_s) = 1 - \text{EXP}(-((H_s - B)/A)^k)$

A = 5.592 FEET

B = 11.913 FEET

CORRELATION = 0.9674

SUM SQUARE OF RESIDUALS = 0.3568 FEET

RANK	Hsm (Ft)	F(Hs<=Hsm) Eq. 3	Ym Eq. 5	A*Ym+B (Ft) Eq. 4	Hsm-(A*Ym+B) (Ft)
1	30.58	0.9741	3.652	32.3332	-1.7558
2	26.61	0.9251	2.592	26.4053	0.2023
3	23.59	0.8762	2.089	23.5930	-0.0038
4	23.16	0.8272	1.756	21.7306	1.4321
5	20.90	0.7783	1.506	20.3359	0.5630
6	20.18	0.7293	1.307	19.2206	0.9566
7	19.78	0.6804	1.141	18.2912	1.4923
8	18.77	0.6314	0.998	17.4944	1.2720
9	16.14	0.5825	0.873	16.7972	-0.6555
10	16.08	0.5335	0.763	16.1773	-0.1012
11	15.68	0.4846	0.663	15.6194	0.0630
12	15.32	0.4356	0.572	15.1121	0.2094
13	15.22	0.3867	0.489	14.6470	0.5761
14	13.75	0.3377	0.412	14.2177	-0.4710
15	10.04	0.2888	0.341	13.8190	-3.7796

RETURN PERIOD TABLE with 90% CONFIDENCE INTERVAL

RETURN PERIOD (Yr)	Hs (Ft) Eq. 6	SIGR (Ft) Eq. 10	Hs-1.28*SIGR (Ft)	Hs+1.28*SIGR (Ft)
2.00	15.79	1.41	13.46	18.12
5.00	20.91	2.75	16.38	25.45
10.00	24.79	4.18	17.89	31.68
25.00	29.91	6.17	19.73	40.10
50.00	33.79	7.71	21.07	46.51
100.00	37.66	9.25	22.39	52.93

(Table 1-3-1 Continued on the Next Page)

(Table 1-3-1 Continued)

WEIBULL DISTRIBUTION $k = 1.40$

$$F(H_s) = 1 - \exp(-((H_s - B)/A)^{k+1})$$

$$A = 9.115 \text{ FEET}$$

$$B = 8.756 \text{ FEET}$$

$$\text{CORRELATION} = 0.9818$$

$$\text{SUM SQUARE OF RESIDUALS} = 0.2201 \text{ FEET}$$

RANK	Hsm (Ft)	F(Hs ≤ Hsm) Eq. 3	Ym Eq. 5	A*Ym+B (Ft) Eq. 4	Hsm-(A*Ym+B) (Ft)
1	30.58	0.9720	2.484	31.3960	-0.8185
2	26.61	0.9229	1.959	26.6092	-0.0016
3	23.59	0.8739	1.682	24.0859	-0.4967
4	23.16	0.8249	1.487	22.3067	0.8561
5	20.90	0.7758	1.333	20.9058	-0.0068
6	20.18	0.7268	1.204	19.7347	0.4424
7	19.78	0.6778	1.093	18.7179	1.0655
8	18.77	0.6287	0.993	17.8111	0.9553
9	16.14	0.5797	0.903	16.9861	-0.8444
10	16.08	0.5307	0.819	16.2233	-0.1472
11	15.68	0.4816	0.741	15.5087	0.1737
12	15.32	0.4326	0.667	14.8314	0.4901
13	15.22	0.3836	0.595	14.1826	1.0405
14	13.75	0.3345	0.526	13.5545	0.1922
15	10.04	0.2855	0.459	12.9400	-2.9007

RETURN PERIOD TABLE with 90% CONFIDENCE INTERVAL

RETURN PERIOD (Yr)	Hs (Ft) Eq. 6	SIGR (Ft) Eq. 10	Hs-1.28*SIGR (Ft)	Hs+1.28*SIGR (Ft)
2.00	15.77	1.45	13.37	18.17
5.00	21.56	2.63	17.22	25.91
10.00	25.29	3.66	19.25	31.34
25.00	29.76	4.97	21.56	37.96
50.00	32.90	5.91	23.16	42.65
100.00	35.89	6.80	24.66	47.12

(Table 1-3-1 Continued on the Next Page)

(Table 1-3-1 Concluded)

WEIBULL DISTRIBUTION $k = 2.00$

$$F(H_s) = 1 - \text{EXP}(-((H_s - B)/A)^k)$$

A = 14.115 FEET

B = 4.112 FEET

CORRELATION = 0.9866

SUM SQUARE OF RESIDUALS = 0.1034 FEET

RANK	H _m (Ft)	F(H _s ≤ H _m) Eq. 3	Y _m Eq. 5	A*Y _m +B (Ft) Eq. 4	H _m -(A*Y _m +B) (Ft)
1	30.58	0.9701	1.873	30.5547	0.0228
2	26.61	0.9210	1.593	26.5991	0.0085
3	23.59	0.8719	1.433	24.3450	-0.7557
4	23.16	0.8228	1.315	22.6789	0.4838
5	20.90	0.7737	1.219	21.3167	-0.4178
6	20.18	0.7245	1.135	20.1395	0.0376
7	19.78	0.6754	1.061	19.0852	0.6983
8	18.77	0.6263	0.992	18.1165	0.6500
9	16.14	0.5772	0.928	17.2087	-1.0670
10	16.08	0.5281	0.867	16.3443	-0.2682
11	15.68	0.4790	0.807	15.5096	0.1728
12	15.32	0.4299	0.750	14.6931	0.6285
13	15.22	0.3808	0.692	13.8842	1.3389
14	13.75	0.3317	0.635	13.0725	0.6742
15	10.04	0.2826	0.576	12.2461	-2.2067

RETURN PERIOD TABLE with 90% CONFIDENCE INTERVAL

RETURN PERIOD (Yr)	H _s (Ft) Eq. 6	SIGR (Ft) Eq. 10	H _s -1.28*SIGR (Ft)	H _s +1.28*SIGR (Ft)
2.00	15.86	1.51	13.37	18.36
5.00	22.02	2.55	17.81	26.23
10.00	25.53	3.32	20.06	31.00
25.00	29.44	4.22	22.48	36.39
50.00	32.03	4.83	24.06	40.00
100.00	34.40	5.40	25.50	43.30

Screen Plots

This application generates five plots. The plots may be accessed from the **EXTREMAL WAVE HEIGHT PLOT MENU**, which appears when the **Plot Output Data** option (**F5**) from the **Activity Menu** is requested. To access a plot, move the cursor (using the arrow keys) to the desired plot and press **F1**. (Appendix C describes options to customize plots.) The plots generated are shown in Figures 1-3-1 through 1-3-5.

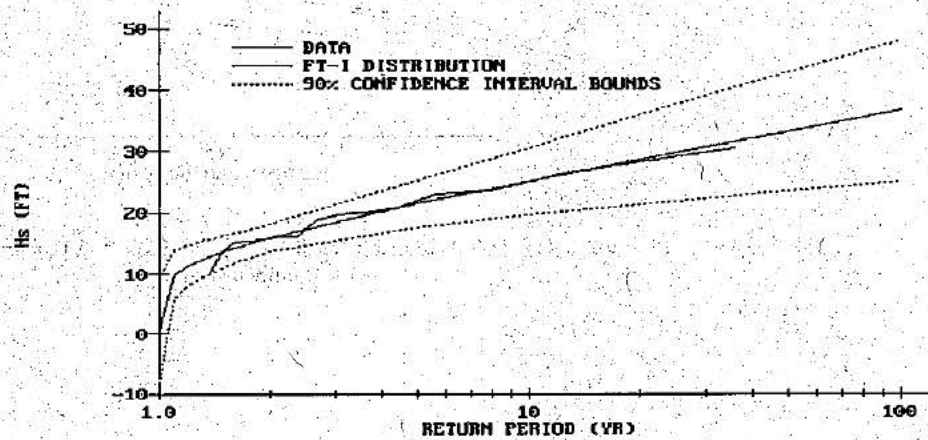

Figure 1-3-1. Fisher-Tippett Distribution and Expected Extreme Wave Heights with Confidence Limits

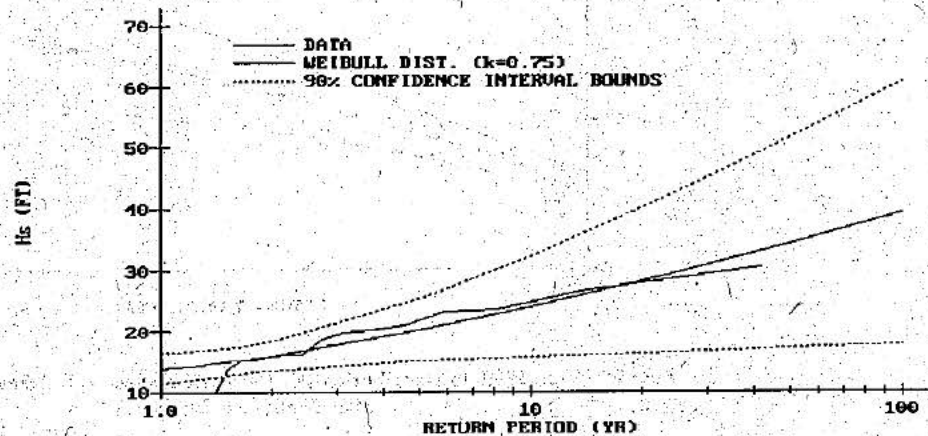

Figure 1-3-2. Weibull Distribution ($k=0.75$) and Expected Extreme Wave Heights with Confidence Limits

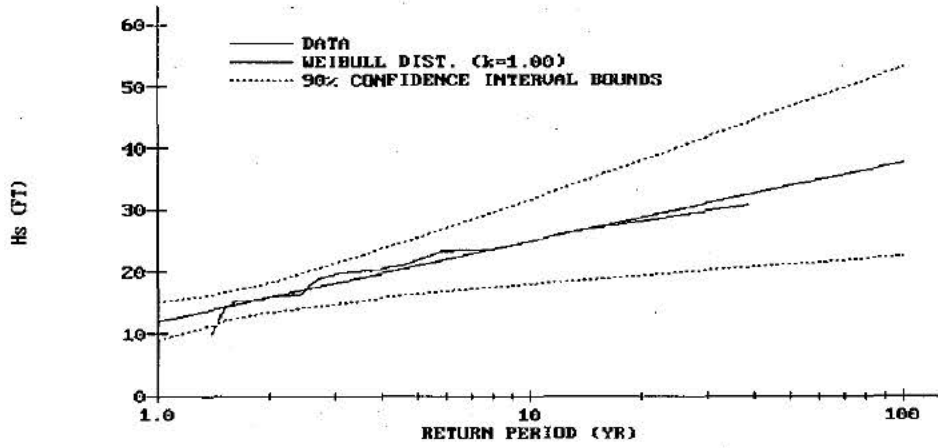

Figure 1-3-3. Weibull Distribution ($k=1.00$) and Expected Extreme Wave Heights with Confidence Limits

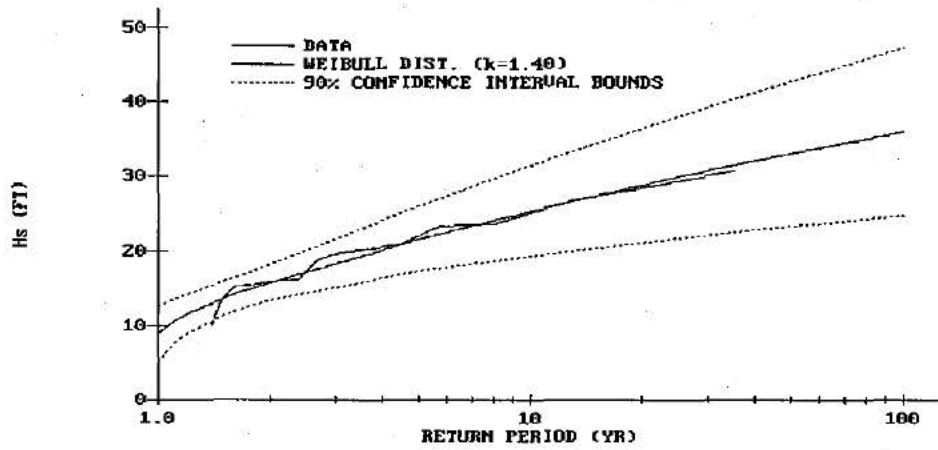

Figure 1-3-4. Weibull Distribution ($k=1.40$) and Expected Extreme Wave Heights with Confidence Limits

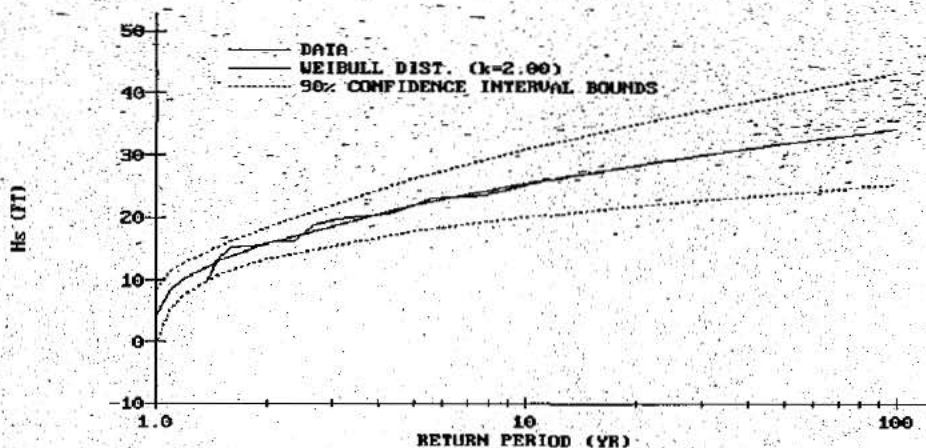

Figure 1-3-5. Weibull Distribution ($k=2.00$) and Expected Extreme Wave Heights with Confidence Limits

REFERENCES AND BIBLIOGRAPHY

- Goda, Y. 1988. "On the Methodology of Selecting Design Wave Height," *Proceedings, Twenty-first Coastal Engineering Conference*, American Society of Civil Engineers, Costa del Sol-Malaga, Spain, pp. 899-913.
- Gringorten, I. I. 1963. "A Plotting Rule for Extreme Probability Paper," *Journal of Geophysical Research*, Vol. 68, No. 3, pp. 813-814.
- Gumbel, E. J. 1958. *Statistics of Extremes*, Columbia University Press, New York.
- Muir, L. R., and El-Shaarawi, A. H. 1986. "On the Calculation of Extreme Wave Heights: A Review," *Ocean Engineering*, Vol. 13, No. 1, pp. 93-118.
- Petrauskas, C., and Aagaard, P. M. 1970. "Extrapolation of Historical Storm Data for Estimating Design Wave Heights," *Proceedings, 2nd Offshore Technology Conference*, OTC1190.
- Headquarters, Department of the Army. 1989. "Water Levels and Wave Heights for Coastal Engineering Design," *Engineer Manual 1110-2-1414*, Washington, DC, Chapter 5, pp. 72-80.

CONSTITUENT TIDE RECORD GENERATION

TABLE OF CONTENTS

Description	1-4-1
Input	1-4-1
Output	1-4-1
Plot Output File 1	1-4-1
Procedure	1-4-2
Single Case Mode	1-4-2
Data Entry Options Menu	1-4-2
Initial Case Data Entry	1-4-2
Edit Case in an External File	1-4-3
Activity Menu	1-4-3
Generate the Tide Elevation Record	1-4-3
General Time & Output Specifications	1-4-4
Constituent Data Entry	1-4-4
Write Tide Record to Plot Output File 1	1-4-5
Plot the Tide Record	1-4-5
Example Problem	1-4-6
Input	1-4-6
General Time & Output Specifications Data Entry	1-4-6
Constituent Data Entry	1-4-6
Output	1-4-7
Screen Plot	1-4-7
Plot Output File 1	1-4-8
References and Bibliography	1-4-8

CONSTITUENT TIDE RECORD GENERATION

DESCRIPTION

This ACES application predicts a tide elevation record at a specific time and locale using known amplitudes and epochs for individual harmonic constituents.

INPUT

The input requirements of this application consist of two general types of information.

- General temporal data.
- Constituent data for the particular desired location.

Data input to this application is accomplished by interaction with several input screens or by reading data from an external file. Detailed lists of the screens and input parameters are presented in the *Procedure* section of this document.

OUTPUT

This application generates one plot (see section titled **Plot Output Data**). In addition, there is an option to send data to plot output file 1 (default name **PLOTDAT1.OUT**). The contents and organization of output data in the plot output file are summarized below.

Plot Output File 1

This file contains the tide elevation at specific times. Plot output file 1 is written in the following format:

Field	Columns	Format	Data
1	1-8	F8.2	Time in hours from beginning of simulation
2	19-26	F8.2	Elevation of the tide

PROCEDURE

This application provides only a Single Case Mode. The Multiple Case Mode is not available. Single Case Mode requires interaction with the application and provides two options of interactive participation. The first option allows entering new data sets, and the second option allows editing of data sets read from an external file.

Single Case Mode

The bulleted items in the following lists indicate potentially optional instruction steps. Any application in ACES may be executed in a given session without quitting the program. The bulleted items provide instructions for accessing the application from various menu areas of the ACES program. Ignore bulleted instruction steps that are not applicable.

- Press **F1** on the Main Menu to select Single Case Mode.
- Fill in the highlighted input fields on the General Specifications screen (or leave the default values). *For information on input requirements on the General Specifications screen, please refer to the section of the User's Guide entitled "General Instructions and Information."* Press **F1** when all data on this screen are correct.
- Press **F1** on the Functional Area Menu to select Wave Prediction.
- Press **F4** on the Wave Prediction Menu to select Constituent Tide Record Generation.

Data Entry Options Menu

This menu provides two options of interactive participation with the application:

Initial Case Data Entry

Use **F1** option to enter an initial (new) set of data. These data will be written to the *Trace Output* file and become available for subsequent editing and use.

Edit Case in an External File

Use **(Alt) F1** option to access and modify data from an external file. This external data file is created by saving (or copying) a trace file from a previous execution of this application. The format and contents of the trace file for this application match exactly the requirements of this input file. The default input file name is **TIDES.IN**, but other filenames (including pathname) are acceptable. After entering the filename, press **(ENTER)** to accept this file. *For more information on files, see the section of this manual entitled "General Instructions and Information."*

Activity Menu

The Activity Menu is a pivotal point from which all options for Single Case data entry, modification, and execution are accessible. The options are:

- (F1)** Generate the Tide Elevation Record.
- (F2)** General Time & Output Specifications.
- (F3)** Constituent Data Entry.
- (F4)** Write Tide Record to *current plot output filename*.
- (F5)** Plot the Tide Record.
- (F10)** Exit Menu.

Each option and the required data are described below.

(F1) Generate the Tide Elevation Record

Use this option only after all data have been entered.

F2 General Time & Output Specifications

This screen provides for input of general parameters required to run the application. Values for all parameters listed except *Description* are required.

<u>Item</u>	<u>Units</u>	<u>Data Range</u>	
Simulation Start Time:			
Year		1900	to 2050
Month		1	to 12
Day		1	to 31
Hour		0	to 24
Length of Record	hr	0	to 744
Output Time Interval	hr,min	1	to 60
Mean Water Level Height above Datum	ft,m	-100	to 100
Description	alphanumeric		

CAUTION: The number of points used in calculating the tide record is determined by dividing the *Length of Record* by the *Output Time Interval*. A maximum of 1,500 points are allowed by this application. If this maximum is exceeded, an error message will be displayed on screen.

NOTE: When all required data have been entered on this screen, press **F10** to return to the Activity Menu.

F3 Constituent Data Entry

This series of screens provides for input of constituent data (amplitude and epoch) for any of 37 constituents. The major tidal constituents accepted by this application are listed in Table A-5 in Appendix A.

<u>Item</u>	<u>Units</u>	<u>Data Range</u>	
Gage Longitude	deg West	-180.0	to 180.00
Amplitude Units	ft,m		
Amplitude of Individual Constituent _n	ft,m	0.0	to 999.99

Epoch of Individual Constituent_n deg 0.0 to 360.00

NOTE: The symbols of 37 common harmonic constituents (see Table A-5 in Appendix A) are displayed on a series of screens. Place the values of amplitude and epoch by the appropriate desired constituent symbol.

Press **F1** to continue additional *constituent* input on subsequent screens. When finished entering all data, press **F10** to return to the Activity Menu.

The number of constituents needed to describe the astronomical tide varies with the location. More terms are needed where the tide must travel a great distance over shallow water than when the tide station is near the open sea. Additional terms may be needed to obtain an adequate representation when the tidal range is large rather than small (Harris, 1981). In the United States, 37 standards constituents (Table A-5, Appendix A) are found to be adequate for most tide stations (Schureman, 1971). These harmonic constituents are available for many US locations from the National Ocean Survey.

F4 Write Tide Record to Plot Output File 1

This option generates a plot output file (default name **PLOTDAT1.OUT**) containing tide elevations at specific times. Plot output file 1 is written in the following format (see Table 1-4-1 in the Example Problem):

Field	Columns	Format	Data
1	1-8	F8.2	Time in hours from beginning of simulation
2	19-26	F8.2	Elevation of the tide

F5 Plot the Tide Record

This application generates one plot (see Figure 1-4-1 in the Example Problem) consisting of the tide elevation against time for the *Length of Simulation* specified on the **General Time & Output Specifications** screen..

EXAMPLE PROBLEM

Input

F2 General Time & Output Specifications Data Entry

<u>Item</u>	<u>Value</u>	<u>Units</u>
Simulation Start Time:		
Year	1989	
Month	1	
Day	10	
Hour	10.00	
Length of Record	120.00	hr
Output Time Interval	15.00	min
Mean Water Height above Datum	1.79	ft
Description	Buzzards Bay Entrance, MA (Datum MLLW)	

F3 Constituent Data Entry

<u>Item</u>	<u>Value</u>	<u>Units</u>
Gage Longitude	70.62	deg West
Amplitude Units		ft

Constituents	Amplitude	Epoch
M ₂	1.621	269.90
S ₂	0.303	283.60
N ₂	0.447	245.10
K ₁	0.262	114.00
M ₄	0.266	136.70
O ₁	0.221	123.90
M ₆	0.070	241.90
MK ₃	0.045	138.00
MN ₄	0.113	82.20
NU ₂	0.077	262.20
MU ₂	0.070	225.00
2N ₂	0.071	225.70
LAMBDA ₂	0.011	276.30
S ₁	0.038	55.30
M ₁	0.016	119.00
J ₁	0.017	109.00
SSA	0.037	44.60

(Constituent Data Entry continued on the next page)

(Constituent Data Entry concluded)

SA	0.112	151.60
Q ₁	0.045	112.60
T ₂	0.018	283.60
P ₁	0.091	123.80
L ₂	0.045	294.70
2MK ₃	0.039	159.00
K ₂	0.091	274.20
MS ₄	0.076	231.00

NOTE: All other harmonic constituents are 0.0 for this example.

Output

Screen Plot

Figure 1-4-1 is the one plot generated for this Example Problem. The plot may be accessed from the Activity menu screen by pressing **FS**.

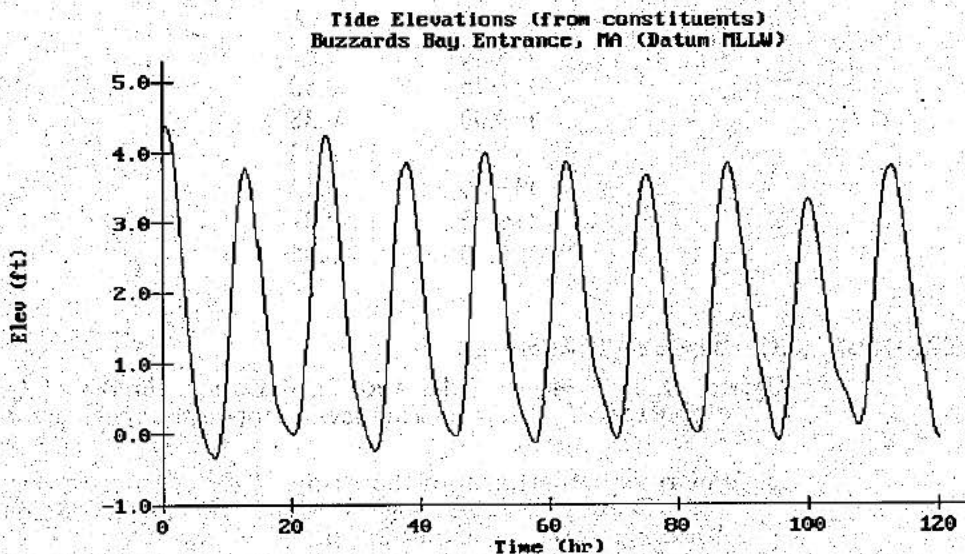

Figure 1-4-1. Tidal Elevation Curve for the Example Problem

Plot Output File 1

In addition to the screen plot, the data can be sent to plot output file 1 (default name **PLOTDAT1.OUT**) by pressing **F4**. This file contains tide elevations at specific times. Table 1-4-1 is a listing of the plot output file 1 for the Example Problem.

Table 1-4-1
Listing of Plot Output File 1 for
Example Problem

CONSTITUENT TIDE
ELEVATION RECORD
Buzzards Bay Entrance, MA
(Datum MLLW)

TIME (hrs)	ELEVATION (feet)
0.00	4.26
0.25	4.35
0.50	4.39
0.75	4.38
1.00	4.32
↓	↓
118.50	0.65
118.75	0.52
119.00	0.38
119.25	0.25
119.50	0.12
119.75	0.01
120.00	-0.08

REFERENCES AND BIBLIOGRAPHY

- Harris, D. L. 1981. "Tides and Tidal Datums in the United States," Special Report SR-7, US Army Engineer Waterways Experiment Station, Vicksburg, MS.
- Headquarters, Department of the Army. 1989. "Water Levels and Wave Heights for Coastal Engineering Design," Engineer Manual 1110-2-1414, Washington, DC, Chapter 2, pp. 5-10.
- Schureman, P. 1971 (reprinted). "Manual of Harmonic Analysis and Prediction of Tides," Coast and Geodetic Survey Special Publication No. 98, Revised (1940) Edition, US Government Printing Office, Washington, DC.

LINEAR WAVE THEORY

TABLE OF CONTENTS

Description	2-1-1
Input	2-1-1
Output	2-1-2
Procedure	2-1-2
Single Case Mode	2-1-2
Multiple Case Mode	2-1-3
Example Problem	2-1-4
Input	2-1-4
Output	2-1-4
References and Bibliography	2-1-5

LINEAR WAVE THEORY

DESCRIPTION

This application yields first-order approximations for various parameters of wave motion as predicted by the wave theory bearing the same name (also known as small-amplitude, sinusoidal, or Airy theory). It provides estimates for common items of interest such as water surface elevation, general wave properties, particle kinematics, and pressure as functions of wave height and period, water depth, and position in the wave form.

INPUT

The coordinate system and terminology used to define linear wave motion are shown in Figure 2-1-1.

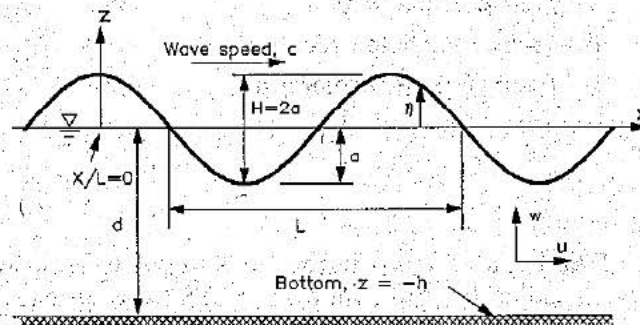

Figure 2-1-1. Small-Amplitude Wave System

All data input for this application is done on one screen. The following list describes the necessary input parameters with their corresponding units and range of data recognized by this application:

Item	Symbol	Units	Data Range
Wave height	H	ft, m	0.1 to 200.0
Wave period	T	sec	1.0 to 1000.0
Water depth	d	ft, m	0.1 to 5000.0
Vertical coordinate	z	ft, m	-5100.0 to 100.0
Horizontal coordinate as a fraction of wavelength	X/L		0.0 to 1.0

OUTPUT

Results from this application are displayed on one screen. Those data include the original input values (in final units) and the following parameters:

<u>Item</u>	<u>Symbol</u>	<u>English Units</u>	<u>Metric Units</u>
Wavelength	L	ft	m
Wave celerity	C	ft/sec	m/sec
Group velocity	C_g	ft/sec	m/sec
Energy density	E	ft-lb/ft ²	N-m/m ²
Energy flux	P	ft-lb/sec-ft	N-m/sec-m
Ursell number	U_r		
Surface elevation	η	ft	m
Horizontal particle displacement	ξ	ft	m
Vertical particle displacement	ζ	ft	m
Horizontal particle velocity	u	ft/sec	m/sec
Vertical particle velocity	w	ft/sec	m/sec
Horizontal particle acceleration	$\partial u / \partial t$	ft/sec ²	m/sec ²
Vertical particle acceleration	$\partial w / \partial t$	ft/sec ²	m/sec ²
Pressure	p	lb/ft ²	N/m ²

PROCEDURE

The bulleted items in the following lists indicate potentially optional instruction steps. Any application in ACES may be executed in a given session without quitting the program. The bulleted items provide instructions for accessing the application from various menu areas of the ACES program. Ignore bulleted instruction that are not applicable.

Single Case Mode

- Press **F1** on the Main Menu to select Single Case Mode.
- Fill in the highlighted input fields on the General Specifications screen (or leave the default values). Press **F1** when all data on this screen are correct.
- Press **F2** on the Functional Area Menu to select Wave Theory.
- Press **F1** on the Wave Theory Application Menu to select Linear Wave Theory.

1. Fill in the highlighted input fields on the Linear Wave Theory screen. Respond to any corrective instructions appearing at the bottom of the screen. Press **(F1)** when all data on this screen are correct.
2. All input and output data are displayed on the screen in the final system of units.
3. Press one of the following keys to select the appropriate action:
 - (F1)** Return to Step 1 for a new case.
 - (F3)** Send a summary of this case to the print file or device.
 - (F10)** Exit this application and return to the Wave Theory Application Menu.

Multiple Case Mode

- Press **(F2)** on the Main Menu to select Multi Case Mode.
 - Fill in the highlighted input fields on the General Specifications screen (or leave the default values). Press **(F1)** when all data on this screen are correct.
 - Press **(F2)** on the Functional Area Menu to select Wave Theory.
 - Press **(F1)** on the Wave Theory Application Menu to select Linear Wave Theory.
1. Move the cursor to select a variable on the Linear Wave Theory screen (the selected variable name blinks). The current set of values for the variable is displayed on the right portion of the screen. When all variable sets are correct, go to Step 3.
 2. Enter a set of values for the subject variable by following one of the input methods:
 - a. Press **(R)** to select random method. Enter up to 20 values constituting a set for this variable (one in each field) on the right side of the screen. The set of 20 values originally displayed (first execution) in these fields contains the "delimiting" value, which "delimits" or "ends" the set. The "delimiting" value is *not* included as a member in the set unless it is the sole member.
 - b. Press **(I)** to select incremental method. Fill in the fields for minimum, maximum, and increment values for this variable on the right side of the screen. In this method, the members of the set include all values from the minimum to the maximum (both inclusive) at the specified increment.

The units field should also be specified for the variable regardless of input method. All members of a set of values for a subject variable are assigned the specified units. When all data are correct for the subject variable, press

F10 to return to Step 1. Errors are reported at the bottom of the screen and are corrected by pressing **F1** to allow respecification of the data for the subject variable.

3. Press **F1** to process the cases resulting from the combinations of the sets of data for all variables. The summary of each case will be sent to the print file or device. The screen will display the total number of cases to be processed as well as report progress. Errors are reported at the bottom of the screen and are corrected by pressing **F1** to allow respecification of variable sets.
4. Press one of the following keys to select the appropriate action:
 - F1** Return to Step 1 to specify new sets.
 - F10** Exit this application and return to the Wave Theory Application Menu.

EXAMPLE PROBLEM

Input

All data input for this application is done on one screen. The values and corresponding units selected for this example are shown below.

<u>Item</u>	<u>Symbol</u>	<u>Value</u>	<u>Units</u>
Wave height	<i>H</i>	6.30	ft
Wave period	<i>T</i>	8.00	sec
Water depth	<i>d</i>	20.00	ft
Vertical coordinate	<i>z</i>	-12.00	ft
Horizontal coordinate as a fraction of wavelength	<i>X/L</i>	0.75	

Output

Results from this application are displayed on one screen. Those data include the original input values and the following parameters (refer to Figure 2-1-2 for location of the parameters):

<u>Item</u>	<u>Symbol</u>	<u>Value</u>	<u>Units</u>
Wavelength	<i>L</i>	189.90	ft
Wave celerity	<i>C</i>	23.74	ft/sec

Group velocity	C_g	20.87	ft/sec
Energy density	E	317.45	ft-lb/ft ²
Energy flux	P	6625.07	ft-lb/sec-ft
Ursell number	U_r	28.40	
Surface elevation	η	0.00	ft
Horizontal particle displacement	ξ	4.59	ft
Vertical particle displacement	ζ	0.00	ft
Horizontal particle velocity	u	0.00	ft/sec
Vertical particle velocity	w	-0.93	ft/sec
Horizontal particle acceleration	$\partial u / \partial t$	-2.83	ft/sec ²
Vertical particle acceleration	$\partial w / \partial t$	0.00	ft/sec ²
Pressure	p	767.83	lb/ft ²

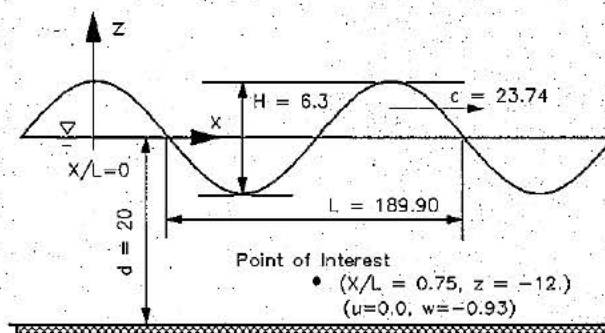

Figure 2-1-2. Linear Wave Theory Example Output

REFERENCES AND BIBLIOGRAPHY

- Airy, G. B. 1845. "Tides and Waves," *Encyclopaedia Metropolitana*, Vol. 192, pp. 241-396.
- Dean, R. G., and Dalrymple, R. A. 1984. *Water Wave Mechanics for Engineers and Scientists*, Prentice-Hall, Englewood Cliffs, NJ, pp. 41-86.
- Hunt, J. N. 1979. "Direct Solution of Wave Dispersion Equation," *Journal of Waterway, Port, Coastal and Ocean Division*, American Society of Civil Engineers, Vol. 105, No. WW4, pp. 457-459.
- Sarpkaya, T., and Isaacson, M. 1981. *Mechanics of Wave Forces on Offshore Structures*, Van Nostrand Reinhold, New York, pp. 150-168.
- Shore Protection Manual*. 1984. 4th ed., 2 Vols., US Army Engineer Waterways Experiment Station, Coastal Engineering Research Center, US Government Printing Office, Washington, DC, Chapter 2, pp. 6-33.
- Stokes, G. G. 1847. "On the Theory of Oscillatory Waves," *Transactions of the Cambridge Philosophical Society*, Vol. 8, pp. 441-455.
- Ursell, F. 1953. "The Long-Wave Paradox in the Theory of Gravity Waves," *Proceedings of the Cambridge Philosophical Society*, Vol. 49, pp. 685-694.

CNOIDAL WAVE THEORY

TABLE OF CONTENTS

Description	2-2-1
Input	2-2-1
Output	2-2-2
Screen Output	2-2-2
Plot Output File 1	2-2-2
Procedure	2-2-3
Single Case Mode	2-2-3
Cnoidal Wave Theory Plot Menu	2-2-4
Multiple Case Mode	2-2-4
Example Problems	2-2-5
Example 1 - First-Order Approximation	2-2-5
Input	2-2-5
Output	2-2-6
Screen Output	2-2-6
Plot Output File 1	2-2-7
Screen Plots	2-2-7
Example 2 - Second-Order Approximation	2-2-9
Input	2-2-9
Output	2-2-9
Screen Output	2-2-9
Plot Output File 1	2-2-10
Screen Plots	2-2-10
References and Bibliography	2-2-12

CNOIDAL WAVE THEORY

DESCRIPTION

This application yields various parameters of wave motion as predicted by first-order (Isobe, 1985) and second-order (Hardy and Kraus, 1987) approximations for cnoidal wave theory. It provides estimates for common items of interest such as water surface elevation, general wave properties, kinematics, and pressure as functions of wave height and period, water depth, and position in the wave form.

INPUT

The coordinate system and terminology used to define cnoidal wave motion is shown in Figure 2-2-1.

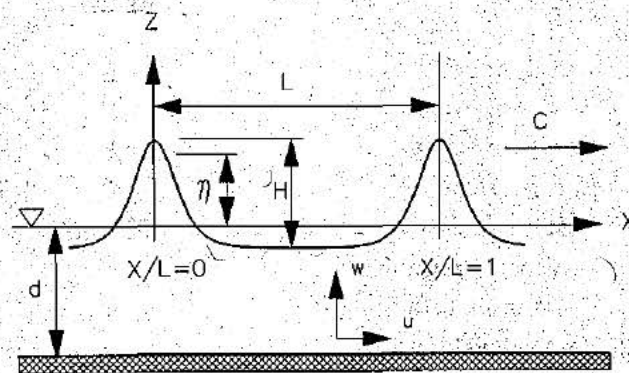

Figure 2-2-1. Progressive Cnoidal Wave System

All data input for this application is done on one screen. The following list describes the necessary input parameters with their corresponding units and range of data recognized by this application:

Item	Symbol	Units	Data Range
Wave height	H	ft, m	0.1 to 200.0
Wave period	T	sec	1.0 to 1000.0
Water depth	d	ft, m	0.1 to 5000.0
Vertical coordinate	z	ft, m	-5100.0 to 100.0

Horizontal coordinate as a fraction of wavelength X/L 0.0 to 1.0
 Order approximation 1 or 2

OUTPUT

Results from this application are written to one screen. In addition, there is an option (available in Single Case Mode only) to send data to plot output file 1 (default name PLOTDAT1.OUT). This application also generates three screen plots. The three plots are described in the *Procedure* section of this document. The screen output and the content of plot output file 1 are described below (refer to the *Example Problem* section for a paradigm).

Screen Output

Results which are displayed on one screen include the original input values (in final units) and the following parameters:

<u>Item</u>	<u>Symbol</u>	<u>English Units</u>	<u>Metric Units</u>
Wavelength	L	ft	m
Wave celerity	C	ft/sec	m/sec
Energy density	E	ft-lb/ft ²	N-m/m ²
Energy flux	P	ft-lb/sec-ft	N-m/sec-m
Ursell number	HL^2/d^3		
Surface elevation	η	ft	m
Horizontal velocity	u	ft/sec	m/sec
Vertical velocity	w	ft/sec	m/sec
Horizontal acceleration	$\partial u / \partial t$	ft/sec ²	m/sec ²
Vertical acceleration	$\partial w / \partial t$	ft/sec ²	m/sec ²
Pressure	p	lb/ft ²	N/m ²

Plot Output File 1

Plot output file 1 contains water surface and velocity values across two wavelengths. The format of the file is described below.

Field	Columns	Format	Data
1	1-10	F10.3	(X/L) horizontal coordinate as a fraction of wavelength
2	11-20	F10.3	(η) water surface elevation
3	21-30	F10.3	(u) horizontal component of the water velocity
4	31-40	F10.3	(w) vertical component of the water velocity

PROCEDURE

The bulleted items in the following lists indicate potentially optional instruction steps. Any application in ACES may be executed in a given session without quitting the program. The bulleted items provide instructions for accessing the application from various menu areas of the ACES program. Ignore bulleted instruction steps that are not applicable.

Single Case Mode

- Press **F1** on the Main Menu to select Single Case Mode.
 - Fill in the highlighted input fields on the General Specifications screen (or leave the default values). Press **F1** when all data on this screen are correct.
 - Press **F2** on the Functional Area Menu to select Wave Theory.
 - Press **F2** on the Wave Theory Application Menu to select Cnoidal Wave Theory.
1. Fill in the highlighted input fields on the Cnoidal Wave Theory screen. Respond to any corrective instructions appearing at the bottom of the screen. Press **F1** when all data on this screen are correct.
 2. All input and output data are displayed on the screen in the final system of units.
 3. Press one of the following keys to select the appropriate action:
 - F1** Return to Step 1 for a new case.
 - F2** Invoke the Plot Menu screen (see the following section titled **Cnoidal Wave Theory Plot Menu**).
 - F3** Send a summary of this case to the print file or device.
 - F4** Generate a file containing plot data (Plot Output File 1).

- F10** Exit this application and return to the Wave Theory Application Menu.

Cnoidal Wave Theory Plot Menu

This application generates three plots. The plots may be accessed from the **CNOIDAL WAVE THEORY PLOT MENU**, which appears when the **Plot Data** option (**F2** key) on the data output screen is selected. To access a plot, move the cursor (using the arrow keys) to the desired selection on the menu and press **F1**. (Appendix C describes options to customize plots.) Available selections are:

- Water Surface Elevation (see Figure 2-2-3)
- Horizontal Velocity (see Figure 2-2-4)
- Vertical Velocity (see Figure 2-2-5)
- ALL PLOTS

NOTE: This option will make all the plots available for viewing. Use the **NEXT** option of the graphics package (Appendix C) to view each plot successively.

- EXIT MENU

Multiple Case Mode

- Press **F2** on the Main Menu to select Multi Case Mode.
 - Fill in the highlighted input fields on the General Specifications screen (or leave the default values). Press **F1** when all data on this screen are correct.
 - Press **F2** on the Functional Area Menu to select Wave Theory.
 - Press **F2** on the Wave Theory Application Menu to select Cnoidal Wave Theory.
1. Move the cursor to select a variable on the Cnoidal Wave Theory screen (the selected variable name blinks). The current set of values for the variable is displayed on the right portion of the screen. When all variable sets are correct, go to Step 3.
 2. Enter a set of values for the subject variable by following one of the input methods:

- a. Press **[R]** to select random method. Enter up to 20 values constituting a set for this variable (one in each field) on the right side of the screen. The set of 20 values originally displayed (first execution) in these fields contains the "delimiting" value, which "delimits" or "ends" the set. The "delimiting" value is *not* included as a member in the set unless it is the sole member.
- b. Press **[I]** to select incremental method. Fill in the fields for minimum, maximum, and increment values for this variable on the right side of the screen. In this method, the members of the set include all values from the minimum to the maximum (both inclusive) at the specified increment.

The units field should also be specified for the variable regardless of input method. All members of a set of values for a subject variable are assigned the specified units. When all data are correct for the subject variable, press **[F10]** to return to Step 1. Errors are reported at the bottom of the screen and are corrected by pressing **[F1]** to allow respecification of the data for the subject variable.

3. Press **[F1]** to process the cases resulting from the combinations of the sets of data for all variables. The summary of each case will be sent to the print file or device. The screen will display the total number of cases to be processed as well as report progress. Errors are reported at the bottom of the screen and are corrected by pressing **[F1]** to allow respecification of variable sets.
4. Press one of the following keys to select the appropriate action:
 - [F1]** Return to Step 1 to specify new sets.
 - [F10]** Exit this application and return to the Wave Theory Application Menu.

NOTE: Multiple Case Mode does not generate any plot output files or plots.

EXAMPLE PROBLEMS

Example 1 - First-Order Approximation

Input

All data input for this application is done on one screen. The values and corresponding units selected for this first example are shown below.

<u>Item</u>	<u>Symbol</u>	<u>Value</u>	<u>Units</u>
Wave height	H	10.00	ft
Wave period	T	15.00	sec
Water depth	d	25.00	ft
Vertical coordinate	z	-12.50	ft
Horizontal coordinate as a fraction of wavelength	X/L	0.50	

Output

Results from this application are written to one screen and, if requested, to plot output file 1 (default name **PLOTDAT1.OUT**). In addition, three screen plots are generated. Each of these outputs for the example problem is presented below.

Screen Output

Results from this application are displayed on one screen. Those data include the original input values and the following parameters (see Figure 2-2-2):

<u>Item</u>	<u>Symbol</u>	<u>Value</u>	<u>Units</u>
Wavelength	L	455.74	ft
Wave celerity	C	30.38	ft/sec
Energy density	E	621.52	ft-lb/ft ²
Energy flux	P	17625.85	ft-lb/sec-ft
Ursell number	HL^2/d^3	132.93	
Surface elevation	η	-2.14	ft
Horizontal velocity	u	-2.43	ft/sec
Vertical velocity	w	0.00	ft/sec
Horizontal acceleration	$\partial u / \partial t$	0.00	ft/sec ²
Vertical acceleration	$\partial w / \partial t$	0.01	ft/sec ²
Pressure	p	643.23	lb/ft ²

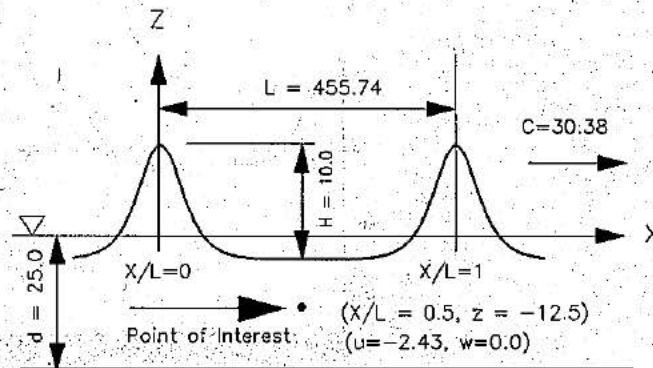

Figure 2-2-2. Cnoidal Theory (First-Order Approximation) Example Output

Plot Output File 1

Table 2-2-1 below is a partial listing of plot output file 1 generated (if requested) by this application for the example problem.

Table 2-2-1
Partial Listing of Plot Output File 1 for Example
Problem 1

X/L	ETA (ft)	U (ft/sec)	W (ft/sec)
-1.000	7.860	8.917	0.000
-0.992	7.805	8.854	0.430
-0.984	7.641	8.668	0.841
-0.976	7.376	8.367	1.216
-0.968	7.020	7.963	1.541
-0.960	6.588	7.474	1.807
-0.952	6.096	6.916	2.008
↓	↓	↓	↓
0.952	6.096	6.916	-2.008
0.960	6.588	7.474	-1.807
0.968	7.020	7.963	-1.541
0.976	7.376	8.367	-1.216
0.984	7.641	8.668	-0.841
0.992	7.805	8.854	-0.430

Screen Plots

This application generates three screen plots. Figures 2-2-3 through 2-2-5 are plots of the water surface elevation (ETA) and the horizontal (U) and vertical (W) water velocity as a function of the horizontal coordinate (X/L).

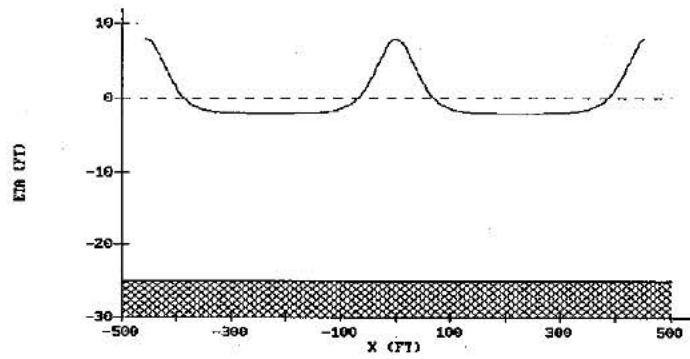

Figure 2-2-3. Water Surface Elevation

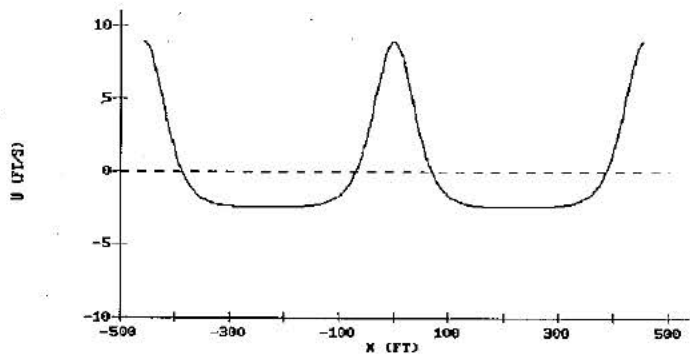

Figure 2-2-4. Horizontal Water Velocity

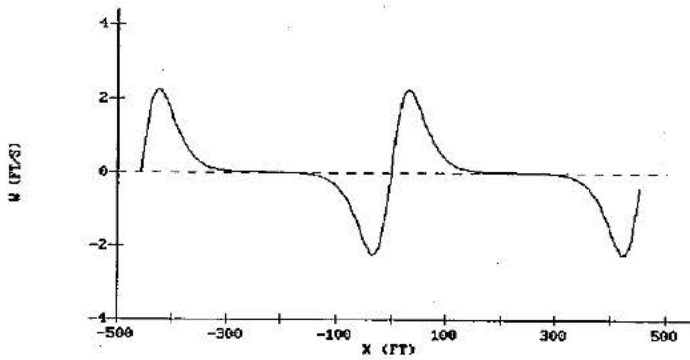

Figure 2-2-5. Vertical Water Velocity

Example 2 - Second-Order Approximation**Input**

All data input for this application is done on one screen. The values and corresponding units selected for this second example are shown below.

<u>Item</u>	<u>Symbol</u>	<u>Value</u>	<u>Units</u>
Wave height	H	10.00	ft
Wave period	T	15.00	sec
Water depth	d	25.00	ft
Vertical coordinate	z	-12.50	ft
Horizontal coordinate as a fraction of wavelength	X/L	0.50	

Output

Results from this application are written to one screen and, if requested, to plot output file 1 (default name **PLOTDAT1.OUT**). In addition, three screen plots are generated. Each of these outputs for the example problem is presented below.

Screen Output

Results from this application are displayed on one screen. Those data include the original input values, and the following parameters (see Figure 2-2-6):

<u>Item</u>	<u>Symbol</u>	<u>Value</u>	<u>Units</u>
Wavelength	L	445.78	ft
Wave celerity	C	29.72	ft/sec
Energy density	E	614.59	ft-lb/ft ²
Energy flux	P	17154.86	ft-lb/sec-ft
Ursell number	HL^2/d^3	127.18	
Surface elevation	η	-2.03	ft
Horizontal velocity	u	-2.70	ft/sec
Vertical velocity	w	0.00	ft/sec
Horizontal acceleration	$\partial u / \partial t$	0.00	ft/sec ²
Vertical acceleration	$\partial w / \partial t$	0.01	ft/sec ²
Pressure	p	673.11	lb/ft ²

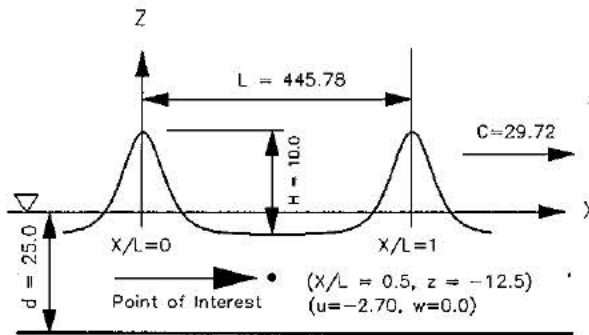

Figure 2-2-6. Cnoidal Theory (Second-Order Approximation) Example Output

Plot Output File 1

Table 2-2-2 below is a partial listing of plot output file 1 generated (if requested) by this application for the second example problem.

Table 2-2-2
Partial Listing of Plot Output File 1 for Example Problem 2

X/L	ETA (ft)	U (ft/sec)	W (ft/sec)
-1.000	7.972	6.601	0.000
-0.992	7.907	6.564	0.177
-0.984	7.716	6.455	0.355
-0.976	7.408	6.277	0.533
-0.968	7.000	6.033	0.708
-0.960	6.510	5.730	0.879
-0.952	5.959	5.374	1.040
-0.944	5.369	4.975	1.185
-0.936	4.761	4.542	1.309
↓	↓	↓	↓
0.944	5.369	4.975	-1.185
0.952	5.959	5.374	-1.040
0.960	6.510	5.730	-0.879
0.968	7.000	6.033	-0.708
0.976	7.408	6.277	-0.533
0.984	7.716	6.455	-0.355
0.992	7.907	6.564	-0.177

Screen Plots

This application generates three screen plots. Figures 2-2-7 through 2-2-9 are plots of the water surface elevation (ETA) and the horizontal (U) and vertical (W) water velocity as a function of the horizontal coordinate (X/L).

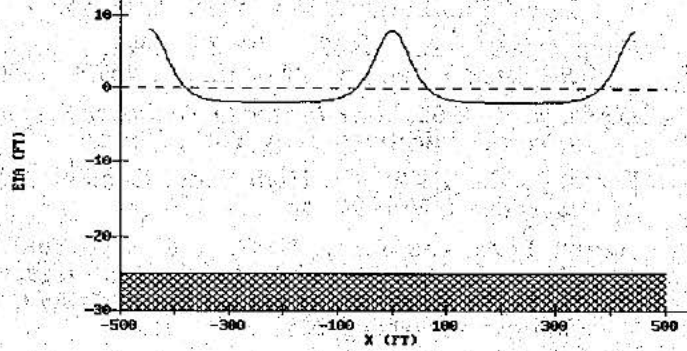

Figure 2-2-7. Water Surface Elevation

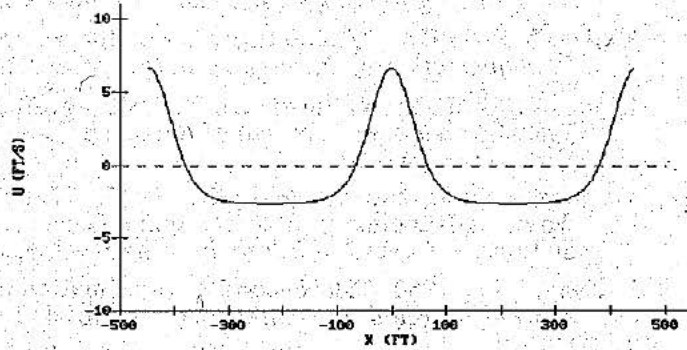

Figure 2-2-8. Horizontal Water Velocity

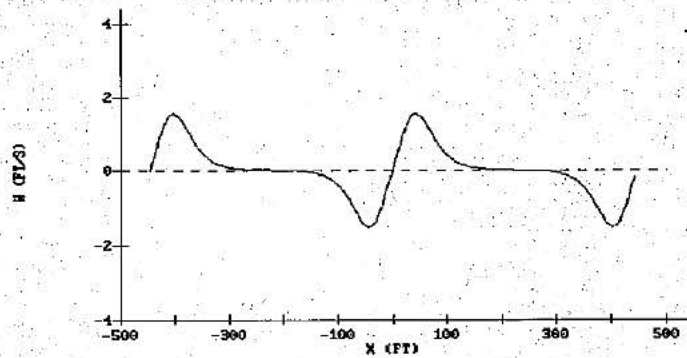

Figure 2-2-9. Vertical Water Velocity

REFERENCES AND BIBLIOGRAPHY

- Abramowitz, M., and Stegun, I. A. 1972. *Handbook of Mathematical Functions*, Dover Publications, New York, 1046 pp.
- Chappelear, J. E. 1962. "Shallow Water Waves," *Journal of Geophysical Research*," Vol. 67, No. 12, pp. 4693-4704.
- Davis, H. T. 1962. *Introduction to Nonlinear Differential and Integral Equations*, Dover Publications, New York, 596 pp.
- Fenton, J. D. 1979. "A High Order Cnoidal Wave Theory," *Journal of Fluid Mechanics*, Vol. 94, pp. 129-161.
- Hardy, T. A., and Kraus, N. C. 1987. "A Numerical Model for Shoaling and Refraction of Second-Order Cnoidal Waves over an Irregular Bottom," Miscellaneous Paper CERC-87-9, US Army Engineer Waterways Experiment Station, Vicksburg, MS.
- Isobe, M. 1985. "Calculation and Application of First-Order Cnoidal Wave Theory," *Coastal Engineering*, Vol. 9, pp. 309-325.
- Isobe, M., and Kraus, N. C. 1983. "Derivation of a Second-Order Cnoidal Wave Theory," Hydraulics Laboratory Report No. YNU-HY-83-2, Department of Civil Engineering, Yokohama National University, 43 pp.
- Keller, J. B. 1948. "The Solitary Wave and Periodic Waves in Shallow Water," *Communication of Pure and Applied Mathematics*, Vol. 1, pp. 323-339.
- Keulegan, G. H., and Patterson, G. W. 1940. "Mathematical Theory of Irrotational Translation Waves," *Journal of Research of the National Bureau of Standards*, Vol. 24, pp. 47-101.
- Korteweg, D. J., and de Vries, G. 1895. "On the Change of Form of Long Waves Advancing in a Rectangular Canal, and on a New Type of Long Stationary Waves," *Philosophy Magazine*, Series 5, Vol. 39, pp. 422-443.
- Laitone, E. V. 1960. "The Second Approximation to Cnoidal and Solitary Waves," *Journal of Fluid Mechanics*, Vol. 9, pp. 430-444.
- Shore Protection Manual*. 1984. 4th ed., 2 Vols., US Army Engineer Waterways Experiment Station, Coastal Engineering Research Center, US Government Printing Office, Washington, DC, Chapter 2, pp. 44-55.
- Stokes, G. G. 1847. "On the Theory of Oscillatory Waves," *Transactions of the Cambridge Philosophical Society*, Vol. 8, pp. 441-455.

FOURIER SERIES WAVE THEORY

TABLE OF CONTENTS

Description	2-3-1
Procedure	2-3-1
Input	2-3-2
Output	2-3-3
Screen Output	2-3-3
First Screen	2-3-3
Second Screen	2-3-4
Plot Output File 1	2-3-5
Screen Plots	2-3-6
Example Problem	2-3-7
Input	2-3-7
Output	2-3-7
Screen Output	2-3-8
First Screen	2-3-8
Second Screen	2-3-8
Plot Output File 1	2-3-9
Screen Plots	2-3-10
References and Bibliography	2-3-14

FOURIER SERIES WAVE THEORY

DESCRIPTION

This application yields various parameters for progressive waves of permanent form, as predicted by Fourier series approximation. It provides estimates for common engineering parameters such as water surface elevation, integral wave properties, and kinematics as functions of wave height, period, water depth, and position in the wave form which is assumed to exist on a uniform co-flowing current. Stokes first and second approximations for celerity (i.e., values of the mean Eulerian current or mean mass transport rate) may be specified. Fourier series of up to 25 terms may be selected to approximate the wave. In addition to providing kinematics at a given point in the wave, this application provides graphical presentations of kinematics over two wavelengths (at a given z coordinate), and the vertical profile of selected kinematics under the wave crest. The methodology is based upon a series of papers by J. D. Fenton (Reinecker and Fenton, 1981; Fenton, 1988a; Fenton, 1988b; Fenton, 1990) and R. J. Sobey (Sobey, Goodwin, Thieke, and Westberg, 1987). LINPACK routines (Dongarra et al., 1979) are used to solve the set of up to 60 simultaneous equations to determine the Fourier coefficients for the series.

PROCEDURE

This section provides instructions for running this application in the **Single Case** mode. The **Multiple Case** mode is not available.

- Press **F1** on the Main Menu to select Single Case Mode.
- Fill in the highlighted input fields on the General Specifications screen (or leave the default values). Press **F1** when all data on this screen are correct.
- Press **F2** on the Functional Area Menu to select Wave Theory.
- Press **F3** on the Wave Theory Application Menu to select Fourier Series Wave Theory.

Input

The coordinate system and terminology used to define Fourier series wave motion are shown in Figure 2-3-1.

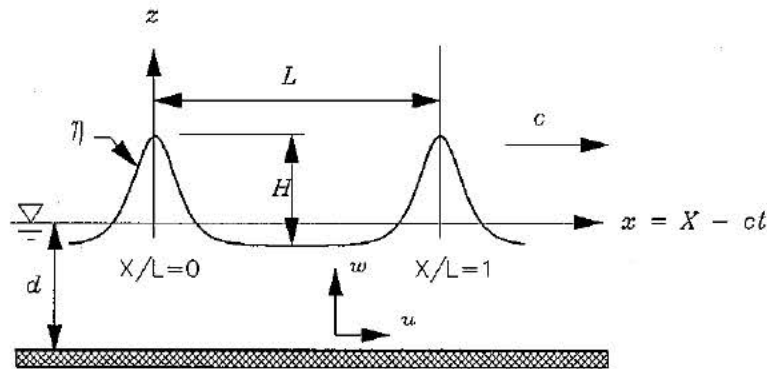

Figure 2-3-1. Progressive Fourier Series Wave System

Initial data input for this application is done on one screen. The following list describes the necessary input parameters with their corresponding units and range of data recognized by this application:

<u>Item</u>	<u>Symbol</u>	<u>Units</u>	<u>Data Range</u>	
Wave height	H	ft, m	0.1	to 200.0
Wave period	T	sec	1.0	to 1000.0
Water depth	d	ft, m	0.1	to 5000.0
Celerity Definition			E(Euler)	or S(Stokes)
Mean Velocity	u	fps, mps	1.0	to 10.0
Number of terms in Fourier Series			1	to 25
Number of steps in Wave Height ramping			1	to 10

In addition to the above input the user has the option to request kinematics (horizontal and vertical velocity and acceleration, pressure, and water surface elevation) at a selected point of interest. This option is presented to the user only after computations are performed using the above initial input values. The option to get kinematics is offered on the *second* screen displaying output and is described in a later section.

When the required input data on the screen are correct, press one of the following keys to select the next appropriate action:

- (F1) Perform computations.
- (F10) Exit this application and return to the Wave Theory Application Menu.

Output

Results from this application are displayed on two screens. In addition, there is an option to send data to plot output file 1 (default name **PLOTDAT1.OUT**). This application also generates nine screen plots. These various outputs are described in the following sections.

Screen Output

First Screen

Results which are displayed on the first screen include the original input values (in final units) and the following parameters:

<u>Item</u>	<u>Symbol</u>	<u>English Units</u>	<u>Metric Units</u>
Celerity		ft/sec	m/sec
Wavelength		ft	m
Mean Eulerian Fluid Velocity		ft/sec	m/sec
Mean Mass Transport Velocity		ft/sec	m/sec
Mean Velocity relative to Wave		ft/sec	m/sec
Volume Flux		ft ² /sec	m ² /sec
Bernoulli Constant		ft ² /sec ²	m ² /sec ²
Impulse	I	lb-sec/ft ²	N-sec/m ²
Kinetic Energy	E_K	ft-lb/ft ²	N-m/m ²
Potential Energy	E_P	ft-lb/ft ²	N-m/m ²
Energy density	E_K+E_P	ft-lb/ft ²	N-m/m ²
Mean Square of Bed Velocity	U_b^2	ft ² /sec ²	m ² /sec ²
Radiation Stress	S_{xx}	ft-lb/ft ²	N-m/m ²
Wave Power (Energy flux)	F	ft-lb/sec-ft	N-m/sec-m
Volume Flux	Q	ft ² /sec	m ² /sec
Bernoulli Constant	R	ft ² /sec ²	m ² /sec ²

After viewing the first output screen press one of the following keys to select the next appropriate action:

- F1** Return to the input screen for a new case.
- F2** Send a summary of this case to the print file or device.
- F5** Invoke the next screen to view additional output results and request kinematics at a particular point of interest.
- F10** Exit this application and return to the Wave Theory Application Menu.

Second Screen

Results displayed on the second screen include the wave surface elevations at the crest and trough, the dimensionless Fourier coefficients, and *if desired*, the following kinematics at a selected point of interest.

Velocity (horizontal and vertical)	U, W	ft/sec	m/sec
Acceleration (horizontal and vertical)	a_x, a_z	ft/sec ²	m/sec ²
Pressure	p	lb/ft ²	N/m ²
Water surface elevation	η	ft	m

After viewing the second output screen, press one of the following keys to select the next appropriate action:

- Y** Invoke the *requestor* for entering the coordinates where kinematics are desired.
- F1** Return to Previous Screen.
- F10** Exit this application and return to the Wave Theory Application Menu.

When **Y** is pressed, a *requestor* is displayed requesting the point of interest where kinematics are desired. Enter a horizontal (X/L) and vertical Z coordinate where kinematics are desired. The horizontal coordinate is entered as a fraction of the wavelength where 1.0 is the crest and 0.5 is the trough. The vertical coordinate is entered as a distance below the wave surface. After the coordinates are entered press **Alt F1** to accept the values and make the computations, or press **Alt F10** to exit the *requestor* and return to the previous screen.

After the kinematic computations have been performed and displayed press one of the following keys to select the next appropriate action:

- F1** Return to Previous Screen.
- F2** Invoke the Plot Menu screen (see section Screen Plots).
- F3** Print the Kinematics.
- F4** Generate a file containing plot data (see section Plot Output File 1).
- F5** Invoke *requestor* for new kinematics location.
- F10** Exit this application and return to the Wave Theory Application Menu.

Plot Output File 1

Plot output file 1 contains two sections. The first section includes horizontal and vertical velocity and acceleration, pressure, and water surface elevation at Z as a function of the horizontal coordinate (X/L). The second section contains the horizontal velocity, vertical acceleration, and pressure under the wave crest.

Section 1 of the plot output file 1

Kinematics at Z (across two wavelengths)

Field	Columns	Format	Data
1	1-10	F10.3	counter
2	11-20	F10.3	(X/L) horizontal coordinate as a fraction of wavelength
3	21-30	F10.3	(η) water surface elevation
4	31-40	F10.3	(U) horizontal component of water velocity
5	41-50	F10.3	(W) vertical component of water velocity
6	51-60	F10.3	(p) pressure
7	61-70	F10.3	(a_x) horizontal acceleration
8	71-80	F10.3	(a_z) vertical acceleration

Section 2 of the plot output file 1

Kinematics Under Wave Crest

Field	Columns	Format	Data
1	1-10	F10.3	counter
2	11-20	F10.3	(Z) vertical coordinate under wave crest
3	21-30	F10.3	(η) water surface elevation
4	31-40	F10.3	(U) horizontal component of water velocity
5	41-50	F10.3	(p) pressure
6	51-60	F10.3	(a_z) vertical acceleration

Screen Plots

This application generates nine plots. The plots may be accessed from the **FOURIER SERIES WAVE THEORY PLOT MENU (KINEMATICS)**, which appears when the **Plot Data** option (**F2** key) on the *second* data output screen is selected. To access a plot, move the cursor (using the arrow keys) to the desired selection on the menu and press **F1**. (Appendix C describes options to customize plots.) Available selections are:

(at Z) Across Two Wavelengths

- Horizontal Velocity (see Figure 2-3-2 of Example Problem)
- Vertical Velocity (see Figure 2-3-3 of Example Problem)
- Horizontal Acceleration (see Figure 2-3-4 of Example Problem)
- Vertical Acceleration (see Figure 2-3-5 of Example Problem)
- Pressure (see Figure 2-3-6 of Example Problem)
- Water Surface Elevation (see Figure 2-3-7 of Example Problem)

Under Wave Crest

- Horizontal Velocity (see Figure 2-3-8 of Example Problem)
- Vertical Acceleration (see Figure 2-3-9 of Example Problem)
- Pressure (see Figure 2-3-10 of Example Problem)

- **ALL PLOTS**

NOTE: This option will make all the plots available for viewing. Use the **NEXT** option of the graphics package (Appendix C) to view each plot successively.

- **EXIT MENU**

EXAMPLE PROBLEM**Input**

Initial data input for this application is done on one screen. The following list describes the necessary input parameters with their corresponding units and range of data recognized by this application:

<u>Item</u>	<u>Symbol</u>	<u>Value</u>	<u>Units</u>
Wave height	H	4.50	ft
Wave period	T	9.00	sec
Water depth	d	22.00	ft
Celerity Definition		E(Euler)	
Mean Velocity	u	0.00	ft/s
Number of terms if Fourier Series		16	
Number of steps in Wave Height ramping		5	

Output

Results from this application are displayed on two screens. In addition, there is an option to send data to plot output file 1 (default name **PLOTDAT1.OUT**). This application also generates nine screen plots. The plots are described in the *Procedure* section of this document. The screen output and the content of plot output file 1 are described below (refer to the **Example Problem** section for a paradigm).

Screen Output*First Screen*

Results which are displayed on the first screen include the original input values (in final units) and the following parameters:

<u>Item</u>	<u>Symbol</u>	<u>Value</u>	<u>Units</u>
Celerity		25.620	ft/sec
Wavelength		230.581	ft
Mean Eulerian Fluid Velocity		0.000	ft/sec
Mean Mass Transport Velocity		0.140	ft/sec
Mean Velocity relative to Wave		25.620	ft/sec
Volume Flux		3.088	ft ² /sec
Bernoulli Constant		329.518	ft ² /sec ²
Impulse	I	0.61411E+01	lb-sec/ft ²
Kinetic Energy	E_K	78.667	ft-lb/ft ²
Potential Energy	E_P	77.306	ft-lb/ft ²
Energy density	E_K+E_P	155.97	ft-lb/ft ²
Mean Square of Bed Velocity	U_b^2	2.6479	ft ² /sec ²
Radiation Stress	S_{xx}	198.62	ft-lb/ft ²
Wave Power (Energy flux)	F	3577.6	ft-lb/sec-ft
Volume Flux	Q	560.55	ft ² /sec
Bernoulli Constant	R	1037.3	ft ² /sec ²

Second Screen

Results displayed on the second screen include the wave surface elevations at the crest and trough, the dimensionless Fourier coefficients, and *if desired*, the following kinematics at the selected point of interest.

Point of interest	$(x/L, Z)$	Horizontal	Vertical	
		0.000	-5.000 ft	
Velocity (horizontal and vertical)	U, W	3.150	0.000	ft/sec
Acceleration (horizontal and vertical)	a_x, a_z	0.000	-1.302	ft/sec ²
Pressure	p	473.223		lb/ft ²
Water surface elevation	η	2.803		ft

Plot Output File 1

Table 2-3-1 below is a partial listing of plot output file 1 generated (if requested) by this application for the example problem.

Table 2-3-1
Partial Listing of Plot Output File 1

Section 1 of the plot output file 1

Kinematics at Z (across 2 wavelengths)

	X/L	ETA (ft)	U(x/L,z) (ft/s)	W(x/L,z) (ft/s)	PRESSURE (lb/ft ²)	a _x (x/L,z) (ft/s ²)	a _z (x/L,z) (ft/s ²)
1	-1.000	2.803	3.150	0.000	473.223	0.000	-1.302
2	-0.992	2.795	3.143	0.107	472.899	0.177	-1.297
3	-0.984	2.773	3.122	0.213	471.927	0.352	-1.280
4	-0.976	2.737	3.087	0.317	470.318	0.525	-1.252
5	-0.968	2.686	3.039	0.419	468.082	0.693	-1.215
6	-0.960	2.623	2.978	0.517	465.238	0.856	-1.167
7	-0.952	2.547	2.904	0.612	461.808	1.012	-1.110
8	-0.944	2.460	2.819	0.701	457.820	1.160	-1.044
9	-0.936	2.362	2.722	0.786	453.303	1.300	-0.971
10	-0.928	2.255	2.615	0.865	448.294	1.429	-0.892
↓	↓	↓	↓	↓	↓	↓	↓
241	0.920	2.140	2.499	-0.937	442.830	-1.548	-0.807
242	0.928	2.255	2.615	-0.865	448.295	-1.429	-0.892
243	0.936	2.362	2.722	-0.786	453.305	-1.300	-0.971
244	0.944	2.460	2.819	-0.701	457.821	-1.160	-1.044
245	0.952	2.547	2.904	-0.612	461.810	-1.012	-1.110
246	0.960	2.623	2.978	-0.517	465.239	-0.856	-1.167
247	0.968	2.686	3.039	-0.419	468.083	-0.693	-1.215
248	0.976	2.737	3.088	-0.317	470.318	-0.525	-1.252
249	0.984	2.773	3.122	-0.213	471.928	-0.352	-1.280
250	0.992	2.795	3.143	-0.107	472.899	-0.177	-1.297
251	1.000	2.803	3.150	0.000	473.223	0.000	-1.302

(Table 2-3-1 Continued on the Next Page)

(Table 2-3-1 Concluded)

Section 2 of the plot output file 1

Kinematics Under Wave Crest

	Z (ft)	ETA (ft)	U(x/L,z) (ft/s)	PRESSURE (lb/ft ²)	a _z (x/L,z) (ft/s ²)
1	-22.000	2.803	2.682	1539.861	0.000
2	-21.901	2.803	2.682	1533.514	-0.007
3	-21.802	2.803	2.682	1527.168	-0.014
4	-21.702	2.803	2.682	1520.823	-0.021
5	-21.603	2.803	2.683	1514.480	-0.028
6	-21.504	2.803	2.683	1508.138	-0.035
7	-21.405	2.803	2.683	1501.797	-0.042
8	-21.306	2.803	2.683	1495.458	-0.049
9	-21.206	2.803	2.683	1489.120	-0.056
10	-21.107	2.803	2.684	1482.784	-0.063
	↓	↓	↓	↓	↓
243	2.009	2.803	3.667	47.563	-1.995
244	2.108	2.803	3.676	41.609	-2.006
245	2.207	2.803	3.685	35.658	-2.017
246	2.307	2.803	3.694	29.709	-2.028
247	2.406	2.803	3.703	23.762	-2.039
248	2.505	2.803	3.712	17.818	-2.050
249	2.604	2.803	3.722	11.875	-2.061
250	2.703	2.803	3.731	5.935	-2.072
251	2.803	2.803	3.740	-0.003	-2.083

Screen Plots

This application generates nine screen plots. Figures 2-3-2 through 2-3-10 are plots of the horizontal and vertical velocity and acceleration, pressure, and water surface elevation at Z as a function of the horizontal coordinate (X/L). Also plotted is the horizontal velocity, vertical acceleration, and pressure under the wave crest.

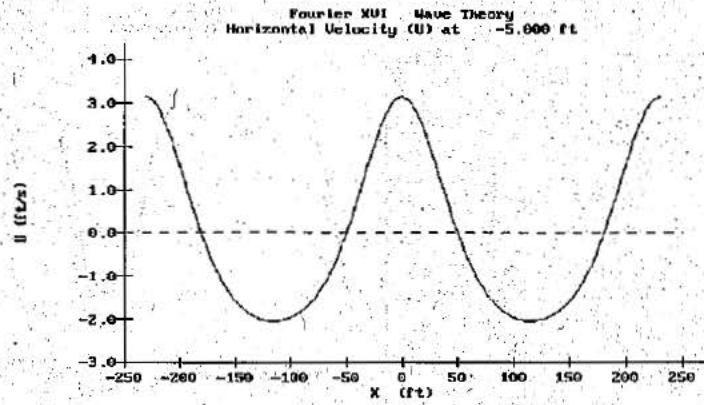

Figure 2-3-2. Horizontal Water Velocity at Z

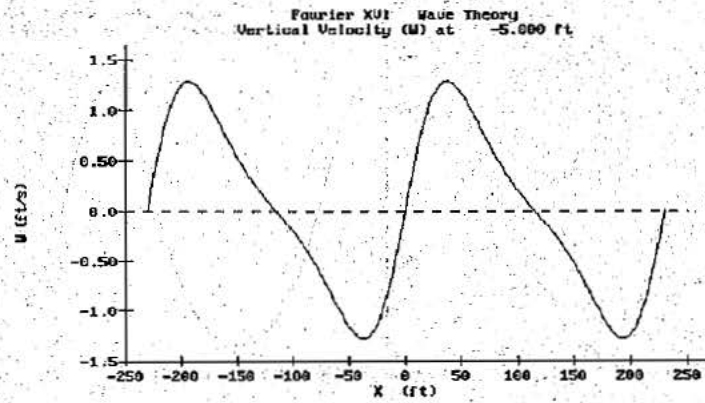

Figure 2-3-3. Vertical Water Velocity at Z

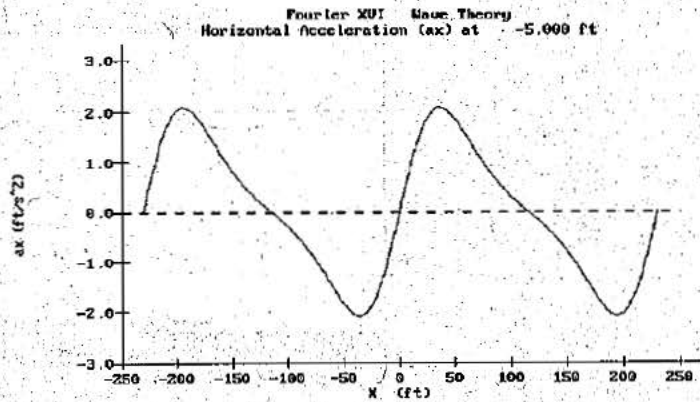

Figure 2-3-4. Horizontal Acceleration at Z

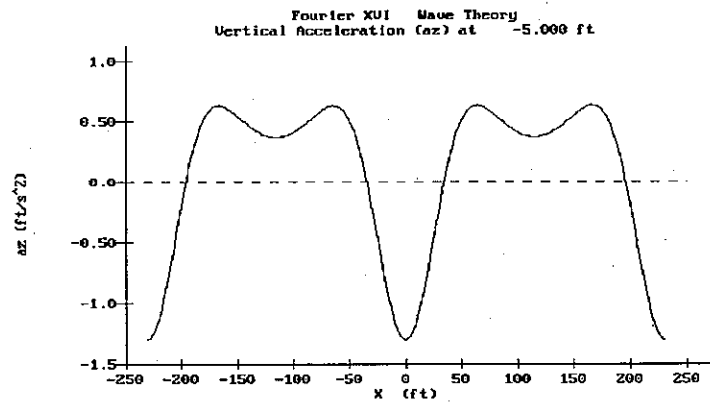

Figure 2-3-5. Vertical Acceleration at Z

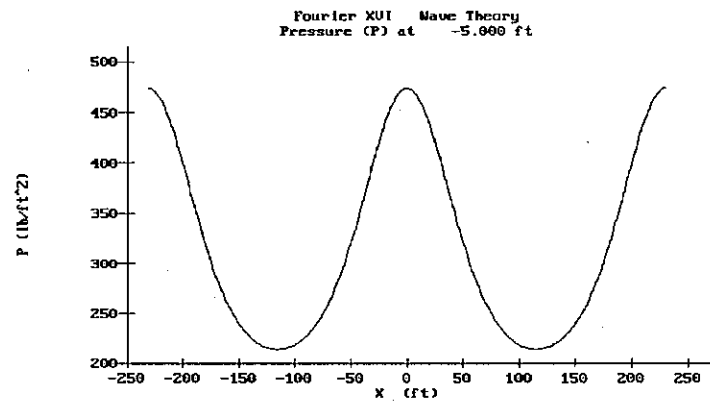

Figure 2-3-6. Pressure at Z

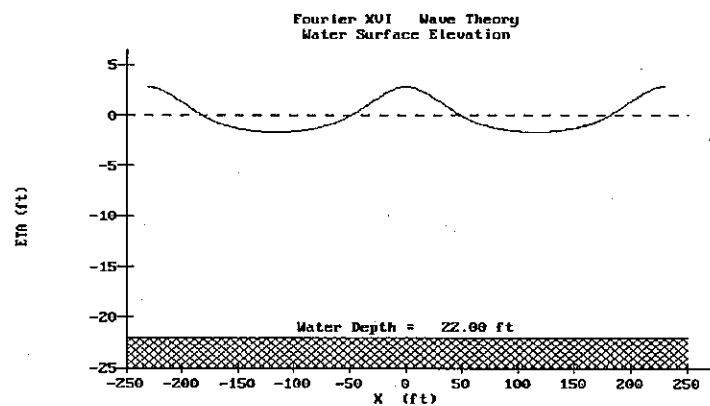

Figure 2-3-7. Water Surface Elevation

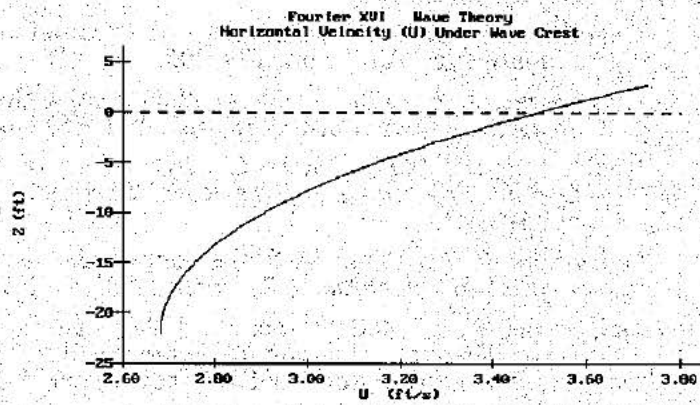

Figure 2-3-8. Horizontal Water Velocity Under Wave Crest

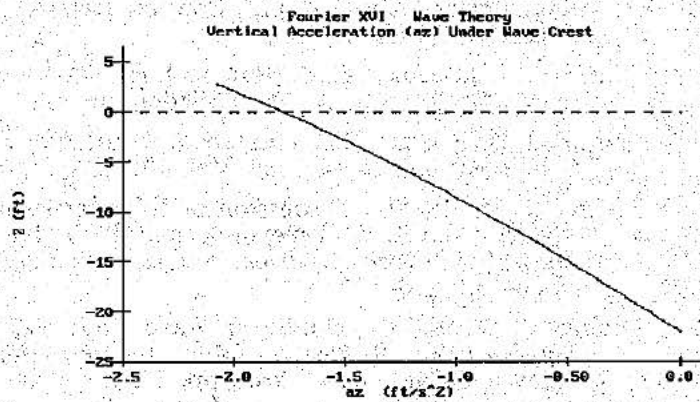

Figure 2-3-9. Vertical Acceleration Under Wave Crest

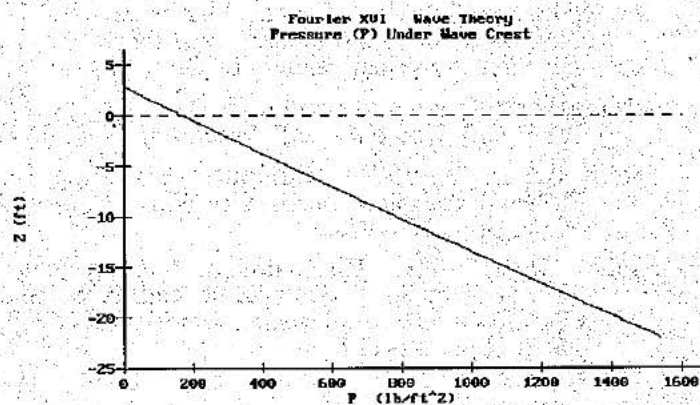

Figure 2-3-10. Pressure Under Wave Crest

REFERENCES AND BIBLIOGRAPHY

- Chaplin, J. R., 1980. "Developments of Stream-Function Wave Theory," *Coastal Engineering*, Vol. 3, pp. 179-205.
- Chappelear, J. E., 1961. "Direct Numerical Calculation of Wave Properties," *Journal of Geophysical Research*, Vol. 66, No. 2, pp. 501-508.
- Cokelet, E. D., 1977. "Steep Gravity Waves in Water of Arbitrary Uniform Depth," *Proceedings of the Royal Society of London, Series A*, Vol. 286, pp. 183-230.
- Dalrymple, R. A., 1974. "A Finite Amplitude Wave on a Linear Shear Current," *Journal of Geophysical Research*, Vol. 79, No. 30, pp. 4498-4504.
- Dalrymple, R. A., and Solana, P., 1986. "Nonuniqueness in Stream Function Wave Theory," *Journal of Waterway, Port, Coastal and Ocean Division*, American Society of Civil Engineers, Vol. 112, No. 2, pp. 333-337.
- Dean, R. G., 1965. "Stream Function Representation of Nonlinear Ocean Waves," *Journal of Geophysical Research*, Vol. 70, No. 18, pp. 4561-4572.
- Dean, R. G., 1974. "Evaluation and Development of Water Wave Theories for Engineering Application," Special Report No. 1, Coastal Engineering Research Center, 2 Vols.
- Dongarra, J. J., Moler, C. B., Bunch, J. R., and Stewart, G. W., 1979. LINPACK User's Guide, S. I. A. M., Philadelphia.
- Fenton, J. D., 1988a. "The Numerical Solution of Steady Water Wave Problems," *Computers and Geoscience*, Vol. 14, No. 3, pp. 357-368.
- Fenton, J. D., 1988b. Discussion of "Nonuniqueness in Stream Function Wave Theory," by R. A. Dalrymple and P. Solana, *Journal of Waterway, Port, Coastal and Ocean Division*, American Society of Civil Engineers, Vol. 114, No. 1, pp. 110-112.
- Fenton, J. D., 1990. "Nonlinear Wave Theories," Ocean Engineering Science, The Sea, Vol. 9, Part A, Edited by Le Mehaute, B., and Hanes, D., John Wiley and Sons, New York, pp. 3-25.
- Klopman, G., 1990. "A Note on Integral Properties of Periodic Gravity Waves in the Case of a Non-zero Mean Eulerian Velocity," *Journal of Fluid Mechanics*, Vol. 211, pp. 609-615.
- Le Mehaute, B., Lu, C. C., and Ulmer, E. W., 1984. "Parametized Solution to Nonlinear Wave Problem," *Journal of Waterway, Port, Coastal and Ocean Division*, American Society of Civil Engineers, Vol. 110, No. 3, pp. 309-320.
- Reinecker, M. M., and Fenton, J. D., 1981. "A Fourier Approximation Method for Steady Water Waves," *Journal of Fluid Mechanics*, Vol. 104, pp. 119-137.
- Schwartz, L. W., 1974. "Computer Extension and Analytical Continuation of Stokes' Expansion for Gravity Waves," *Journal of Fluid Mechanics*, Vol. 62, Part 3, pp. 553-578.
- Sobey, R. J., 1988. Discussion of "Nonuniqueness in Stream Function Wave Theory," by R. A. Dalrymple and P. Solana, *Journal of Waterway, Port, Coastal and Ocean Division*, American Society of Civil Engineers, Vol. 114, No. 1, pp. 112-114.

Sobey, R. J., Goodwin, P., Thieke, R. J., Westberg, R. J. Jr., 1987. "Application of Stokes, Cnoidal, and Fourier Wave Theories," *Journal of Waterway, Port, Coastal and Ocean Division*, American Society of Civil Engineers, Vol. 113, No. 6, pp. 565-587.

Stokes, G. G., 1847. "On the Theory of Oscillatory Waves," *Transactions of the Cambridge Philosophical Society*, Vol. 8, pp. 441-455.

LINEAR WAVE THEORY WITH SNELL'S LAW

TABLE OF CONTENTS

Description	3-1-1
Input	3-1-1
Output	3-1-2
Procedure	3-1-3
Single Case Mode	3-1-3
Multiple Case Mode	3-1-3
Example Problem	3-1-5
Input	3-1-5
Output	3-1-5
References and Bibliography	3-1-6

LINEAR WAVE THEORY WITH SNELL'S LAW

DESCRIPTION

This application provides a simple estimate for wave shoaling and refraction using Snell's law with wave properties predicted by linear wave theory. Given wave properties and a crest angle at a known depth, it predicts the values in deep water and at a subject location specified by a new water depth. An important assumption for this application is that all depth contours are assumed to be straight and parallel. The criteria of Singamsetti and Wind (1980) and Weggel (1972) are employed to provide an estimate for breaker parameters.

INPUT

The coordinate system and terminology used to define wave motion and Snell's law are shown in Figures 3-1-1 and 3-1-2.

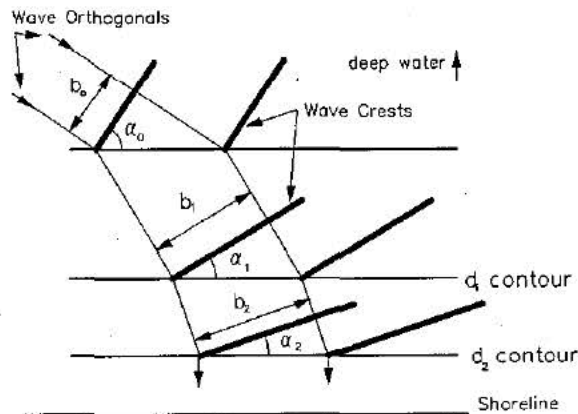

Figure 3-1-1. Snell's Law and Wave Refraction

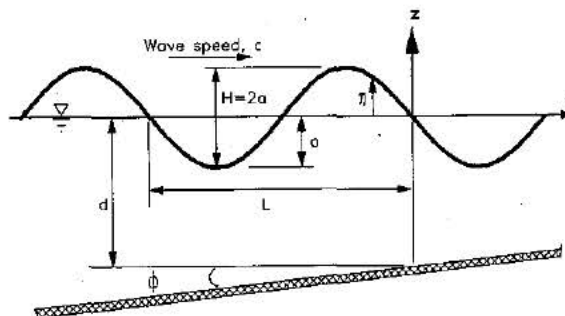

Figure 3-1-2. Progressive Wave on a Nearshore Slope

All data input for this application is done on one screen. The following list describes the necessary input parameters with their corresponding units and range of data recognized by this application:

<u>Location</u>	<u>Item</u>	<u>Symbol</u>	<u>Units</u>	<u>Data Range</u>	
Known	Wave height	H_1	ft, m	0.1	to 200.0
	Wave period	T	sec	1.0	to 1000.0
	Water depth	d_1	ft, m	0.1	to 5000.0
	Wave crest angle	α_1	deg	0.0	to 90.0
	Cotan of nearshore slope	$\cot \phi$		5.0	to 1000.0
Subject	Water depth	d_2	ft, m	0.1	to 5000.0

OUTPUT

Results from this application are displayed on one screen. Those data include the original input values (in final units) and the following parameters:

<u>Item</u>	<u>Wave Location</u>			<u>English Units</u>	<u>Metric Units</u>
	<u>Known</u>	<u>Deep Water</u>	<u>Subject</u>		
Wave height	H_1	H_0	H_2	ft	m
Wave crest angle	α_1	α_0	α_2	deg	deg
Wavelength	L_1	L_0	L_2	ft	m
Wave celerity	c_1	c_0	c_2	ft/sec	m/sec
Group velocity	C_{g1}	C_{g0}	C_{g2}	ft/sec	m/sec
Energy density	E_1	E_0	E_2	ft-lb/ft ²	N-m/m ²
Energy flux	P_1	P_0	P_2	ft-lb/sec-ft	N-m/sec-m
Deepwater wave steepness		H_0/L_0			
Ursell number	$\frac{H_1 L_1^2}{d_1^3}$		$\frac{H_2 L_2^2}{d_2^3}$		

Breaker parameters

<u>Item</u>	<u>Symbol</u>	<u>English Units</u>	<u>Metric Units</u>
Height	H_b	ft	m
Depth	d_b	ft	m

PROCEDURE

The bulleted items in the following lists indicate potentially optional instruction steps. Any application in ACES may be executed in a given session without quitting the program. The bulleted items provide instructions for accessing the application from various menu areas of the ACES program. Ignore bulleted instruction steps that are not applicable.

Single Case Mode

- Press **F1** on the Main Menu to select Single Case Mode.
 - Fill in the highlighted input fields on the General Specifications screen (or leave the default values). Press **F1** when all data on this screen are correct.
 - Press **F3** on the Functional Area Menu to select Wave Transformation.
 - Press **F1** on the Wave Transformation Application Menu to select Linear Wave Theory with Snell's Law.
1. Fill in the highlighted input fields on the Linear Wave Theory with Snell's Law screen. Respond to any corrective instructions appearing at the bottom of the screen. Press **F1** when all data on this screen are correct.
 2. All input and output data are displayed on the screen in the final system of units.
 3. Press one of the following keys to select the appropriate action:
 - F1** Return to Step 1 for a new case.
 - F3** Send a summary of this case to the print file or device.
 - F10** Exit this application and return to the Wave Transformation Application Menu.

Multiple Case Mode

- Press **F2** on the Main Menu to select Multi Case Mode.
- Fill in the highlighted input fields on the General Specifications screen (or leave the default values). Press **F1** when all data on this screen are correct.
- Press **F3** on the Functional Area Menu to select Wave Transformation.
- Press **F1** on the Wave Transformation Application Menu to select Linear Wave Theory with Snell's Law.

1. Move the cursor to select a variable on the Linear Wave Theory with Snell's Law screen (the selected variable name blinks). The current set of values for the variable is displayed on the right portion of the screen. When all variable sets are correct, go to Step 3.
2. Enter a set of values for the subject variable by following one of the input methods:
 - a. Press **(R)** to select random method. Enter up to 20 values constituting a set for this variable (one in each field) on the right side of the screen. The set of 20 values originally displayed (first execution) in these fields contains the "delimiting" value, which "delimits" or "ends" the set. The "delimiting" value is *not* included as a member in the set unless it is the sole member.
 - b. Press **(I)** to select incremental method. Fill in the fields for minimum, maximum, and increment values for this variable on the right side of the screen. In this method, the members of the set include all values from the minimum to the maximum (both inclusive) at the specified increment.

The units field should also be specified for the variable regardless of input method. All members of a set of values for a subject variable are assigned the specified units. When all data are correct for the subject variable, press **(F10)** to return to Step 1. Errors are reported at the bottom of the screen and are corrected by pressing **(F1)** to allow respecification of the data for the subject variable.

3. Press **(F1)** to process the cases resulting from the combinations of the sets of data for all variables. The summary of each case will be sent to the print file or device. The screen will display the total number of cases to be processed as well as report progress. Errors are reported at the bottom of the screen and are corrected by pressing **(F1)** to allow respecification of variable sets.
4. Press one of the following keys to select the appropriate action:
 - (F1)** Return to Step 1 to specify new sets.
 - (F10)** Exit this application and return to the Wave Transformation Application Menu.

EXAMPLE PROBLEM**Input**

All data input for this application is done on one screen. The values and corresponding units selected for this example problem are shown below.

<u>Location</u>	<u>Item</u>	<u>Symbol</u>	<u>Value</u>	<u>Units</u>
Known	Wave height	H_1	10.00	ft
	Wave period	T	7.50	sec
	Water depth	d_1	25.00	ft
	Wave crest angle	α_1	10.00	deg
	Cotan of nearshore slope	$\cot \phi$	100.00	
Subject	Water depth	d_2	20.00	ft

Output

Results from this application are displayed on one screen. Those data include the original input values and the following parameters (see Figure 3-1-3 for location of calculated parameters):

<u>Item</u>	<u>Wave Location</u>			<u>Units</u>
	<u>Known</u>	<u>Deep Water</u>	<u>Subject</u>	
Wave height	10.00	10.68	10.27	ft
Wave crest angle	10.00	15.00	9.12	deg
Wavelength	193.27	288.00	176.34	ft
Wave celerity	25.77	38.40	23.51	ft/sec
Group velocity	21.46	19.20	20.31	ft/sec
Energy density	799.83	911.50	843.04	ft-lb/ft ²
Energy flux	17165.59	17500.84	17121.06	ft-lb/sec-ft
Ursell number	23.91		39.91	
Deepwater wave steepness		0.04		

Breaker parameters

<u>Item</u>	<u>Symbol</u>	<u>Value</u>	<u>Units</u>
Height	H_b	12.29	ft
Depth	d_b	15.25	ft

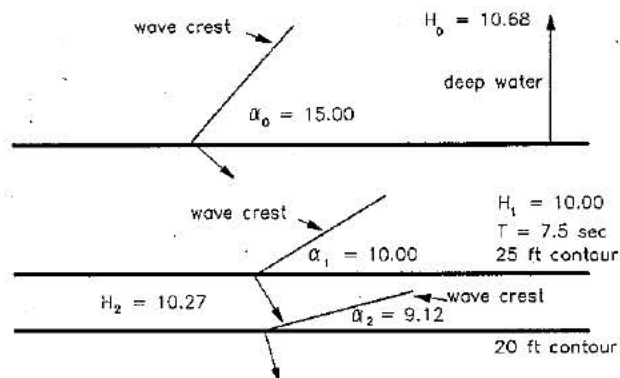

Figure 3-1-3. Snell's Law Example Output

REFERENCES AND BIBLIOGRAPHY

- Airy, G. B. 1845. "Tides and Waves," *Encyclopaedia Metropolitana*, Vol. 192, pp. 241-396.
- Dean, R. G., and Dalrymple, R. A. 1984. *Water Wave Mechanics for Engineers and Scientists*, Prentice-Hall, Englewood Cliffs, NJ, pp. 41-86, 104-105.
- Hunt, J. N. 1979. "Direct Solution of Dispersion Equation," *Journal of Waterway, Port, Coastal and Ocean Division*, American Society of Civil Engineers, Vol. 107, No. WW4, pp. 457-459.
- Le Mehaute, B. 1976. *An Introduction to Hydrodynamics and Water Waves*, Springer-Verlag, New York, pp. 228-232.
- O'Brien, M. P. 1942. "A Summary of the Theory of Oscillatory Waves," Technical Report No. 2, US Army Corps of Engineers, Beach Erosion Board, Washington, DC.
- Sarpkaya, T., and Isaacson, M. 1981. *Mechanics of Wave Forces on Offshore Structures*, Van Nostrand Reinhold, New York, pp. 150-168, 237-242.
- Shore Protection Manual*. 1984. 4th ed., 2 Vols., US Army Engineer Waterways Experiment Station, Coastal Engineering Research Center, US Government Printing Office, Washington, DC, Chapter 2, pp. 6-33, 60-66.
- Singamsetti, S. R., and Wind, H. G. 1980. "Characteristics of Shoaling and Breaking Periodic Waves Normally Incident to Plane Beaches of Constant Slope," *Breaking Waves Publication No. M1371*, Waterstaat, The Netherlands, pp. 23-27.
- Weggel, J. R. 1972. "Maximum Breaker Height," *Journal of Waterways, Harbors and Coastal Engineering Division*, American Society of Civil Engineers, Vol. 98, No. WW4, pp. 529-548.

IRREGULAR WAVE TRANSFORMATION (GODA'S METHOD)

TABLE OF CONTENTS

Description	3-2-1
Input	3-2-1
Output	3-2-2
Screen Output	3-2-2
Plot Output File 1	3-2-2
Screen Plots	3-2-3
Procedure	3-2-3
Single Case Mode	3-2-3
Multiple Case Mode	3-2-4
Example Problem	3-2-5
Input	3-2-5
Output	3-2-5
Screen Output	3-2-6
Plot Output File 1	3-2-7
Screen Plots	3-2-8
References and Bibliography	3-2-9

IRREGULAR WAVE TRANSFORMATION (GODA'S METHOD)

DESCRIPTION

This application yields cumulative probability distributions of wave heights as a field of irregular waves propagate from deep water through the surf zone. The application is based on two random-wave theories by Yoshimi Goda (1975 and 1984). The 1975 paper concerns transformation of random waves shoaling over a plane bottom with straight parallel contours. This analysis treated breaking and broken waves and resulted in cumulative probability distributions for wave heights given a water depth. It did not include refraction, however. The 1984 book details a refraction procedure for random waves propagating over a plane bottom with straight parallel contours assuming a particular incident spectrum. This ACES application combines the two approaches by treating directional random waves propagating over a plane bottom with straight parallel contours. This application also uses the theory of Shuto (1974) for the shoaling calculation. The theories assume a Rayleigh distribution of wave heights in the nearshore zone and a Bretschneider-Mitsuyasu incident directional spectrum.

INPUT

All data input for this application is done on one screen. The following list describes the necessary input parameters with their corresponding units and range of data recognized by this application.

<u>Item</u>	<u>Symbol</u>	<u>Units</u>	<u>Data Range</u>
Significant deepwater wave height	H_o	ft m	2.00 to 20.0 0.61 to 6.09
Water depth	d	ft, m	10.00 to 5000.0
Significant wave period	T_s	sec	4.00 to 16.0
Cotan of nearshore slope	$\cot\phi$		30.00 to 100.0
Principal direction of incident wave spectrum	θ	deg	-75.00 to 75.0

OUTPUT

Results from this application are displayed on one screen. In addition, there is an option (available in the Single Case Mode only) to send data to plot output file 1 (default name **PLOTDAT1.OUT**). This application also generates two screen plots. Each of these outputs is described below.

Screen Output

Results from this application are displayed on one screen. Those data include the original input values (in final units) and the following parameters:

<u>Item</u>	<u>Symbol</u>	<u>English Units</u>	<u>Metric Units</u>
Significant wave height	H_s	ft	m
Mean wave height	H	ft	m
Root-mean-square wave height	H_{rms}	ft	m
Average of highest 10 percent of all waves	H_{10}	ft	m
Average of highest 2 percent of all waves	H_2	ft	m
Maximum wave height	H_{max}	ft	m
Shoaling coefficient	K_s		
Root-mean-square surf beat	ξ	ft	m
Wave setup	S_w	ft	m
Deepwater wave steepness	H_o/L_o		
Effective refraction coefficient	K_r		
Ratio of water depth to deepwater wave height	d/H_o		
Relative water depth	d/L_o		

Plot Output File 1

Plot output file 1 contains wave heights with their cumulative probability distribution of exceedance for both deep water and the specified depth and is available in Single Case Mode only. The data are written to plot output file 1 in the following format (refer to the **Example Problem** section for a paradigm):

Field	Columns	Format	Data
1	1-10	F10.3	Wave height in deep water
2	11-20	F10.3	Cumulative probability distribution of exceedance (CDF)
3	21-30	F10.3	Wave height in water depth of interest
4	31-40	F10.3	Cumulative probability distribution of exceedance (CDF2)

Screen Plots

This application generates two plots. These plots may be accessed by selecting the **Plot Data** option (**F2**) from the **Options** menu on the data output screen. The plots generated are shown in Figures 3-2-1 and 3-2-2 in the example problem below. The first plot displayed is the cumulative probability distribution of exceedance (CDF) versus wave height in deep water. The second plot is the CDF versus wave height in water depth of interest.

PROCEDURE

The bulleted items in the following lists indicate potentially optional instruction steps. Any application in ACES may be executed in a given session without quitting the program. The bulleted items provide instructions for accessing the application from various menu areas of the ACES program. Ignore bulleted instruction steps that are not applicable.

Single Case Mode

- Press **F1** on the Main Menu to select Single Case Mode.
 - Fill in the highlighted input fields on the General Specifications screen (or leave the default values). Press **F1** when all data on this screen are correct.
 - Press **F3** on the Functional Area Menu to select Wave Transformation.
 - Press **F2** on the Wave Transformation Application Menu to select Goda's Wave Transformation.
1. Fill in the highlighted input fields on the Goda's Wave Transformation screen. Respond to any corrective instructions appearing at the bottom of the screen. Press **F1** when all data on this screen are correct.
 2. All input and output data are displayed on the screen in the final system of units.
 3. Press one of the following keys to select the appropriate action:

- F1** Return to Step 1 for a new case.
- F2** Plot the data.
- F3** Send a summary of this case to the print file or device.
- F4** Generate a file containing plot data (cumulative probability versus wave height).
- F10** Exit this application and return to the Wave Transformation Application Menu.

Multiple Case Mode

- Press **F2** on the Main Menu to select Multi Case Mode.
 - Fill in the highlighted input fields on the General Specifications screen (or leave the default values). Press **F1** when all data on this screen are correct.
 - Press **F3** on the Functional Area Menu to select Wave Transformation.
 - Press **F2** on the Wave Transformation Application Menu to select Goda's Wave Transformation.
1. Move the cursor to select a variable on the Goda's Wave Transformation screen (the selected variable name blinks). The current set of values for the variable is displayed on the right portion of the screen. When all variable sets are correct, go to Step 3.
 2. Enter a set of values for the subject variable by following one of the input methods:
 - a. Press **R** to select random method. Enter up to 20 values constituting a set for this variable (one in each field) on the right side of the screen. The set of 20 values originally displayed (first execution) in these fields contains the "delimiting" value, which "delimits" or "ends" the set. The "delimiting" value is *not* included as a member in the set unless it is the sole member.
 - b. Press **I** to select incremental method. Fill in the fields for minimum, maximum, and increment values for this variable on the right side of the screen. In this method, the members of the set include all values from the minimum to the maximum (both inclusive) at the specified increment.

The units field should also be specified for the variable regardless of input method. All members of a set of values for a subject variable are assigned the specified units. When all data are correct for the subject variable, press **F10** to return to Step 1. Errors are reported at the bottom of the screen and are corrected by pressing **F1** to allow respecification of the data for the subject variable.

3. Press **F1** to process the cases resulting from the combinations of the sets of data for all variables. The summary of each case will be sent to the print file or device. The screen will display the total number of cases to be processed as well as report progress. Errors are reported at the bottom of the screen and are corrected by pressing **F1** to allow respecification of variable sets.
4. Press one of the following keys to select the appropriate action:
 - F1** Return to Step 1 to specify new sets.
 - F10** Exit this application and return to the Wave Transformation Application Menu.

NOTE: Multiple Case Mode does not generate any plot output files or plots.

EXAMPLE PROBLEM

Input

All data input for this application is done on one screen. The values and corresponding units selected for this example problem are shown below.

<u>Item</u>	<u>Symbol</u>	<u>Value</u>	<u>Units</u>
Significant deepwater wave height	H_o	20.00	ft
Water depth	d	50.00	ft
Significant wave period	T_s	8.00	sec
Cotan of nearshore slope	$\cot\phi$	100.00	
Principal direction of incident wave spectrum	θ	10.00	deg

Output

Results from this application are displayed on one screen and, if requested, written to plot output file 1 (default name **PLOTDAT1.OUT**). In addition, two plots are generated. Each of these outputs for the example problem is presented below.

Screen Output

Results from this application are displayed on one screen. Those data include the original input values and the following parameters:

<u>Item</u>	<u>Symbol</u>	<u>Subject</u>	<u>Deep Water</u>	<u>Units</u>
Significant wave height	H_s	17.7	20.1	ft
Mean wave height	H	11.2	12.5	ft
Root-mean-square wave height	H_{rms}	12.5	14.1	ft
Average of highest 10 percent of all waves	H_{10}	22.5	27.0	ft
Average of highest 2 percent of all waves	H_2	26.7	32.1	ft
Maximum wave height	H_{max}	30.1	37.6	ft
Shoaling coefficient	K_s	0.9133	1.0000	
Root-mean-square surf beat	ξ	0.4350	0.1766	ft
Wave setup	S_w	-0.0763	-0.0218	ft
Deepwater wave steepness	H_o/L_o	0.0611	0.0611	
Effective refraction coefficient	K_r	0.9638		
Ratio of water depth to deepwater wave height	d/H_o	2.4655	20.0000	
Relative water depth	d/L_o	0.1505	1.2212	

Plot Output File 1

Table 3-2-1 below is a partial listing of plot output file 1 generated by this application.

Table 3-2-1
Wave Height versus Cumulative Probability
Distribution of Exceedance

Deep Water		Water Depth = 50 ft	
H (ft)	CDF	H (ft)	CDF2
0.328	0.001	0.328	0.001
0.656	0.004	0.656	0.003
0.984	0.007	0.984	0.007
1.312	0.011	1.312	0.012
1.640	0.017	1.640	0.018
1.968	0.023	1.968	0.026
2.296	0.030	2.296	0.034
2.624	0.039	2.624	0.044
2.952	0.048	2.952	0.055
3.280	0.058	3.280	0.067
↓	↓	↓	↓
26.240	0.970	26.240	0.995
26.568	0.972	26.568	0.996
26.896	0.975	26.896	0.997
27.224	0.977	27.224	0.998
27.552	0.979	27.552	0.998
27.880	0.981	27.880	0.999
28.208	0.982		
28.536	0.984		
28.864	0.985		
29.192	0.987		
↓	↓		
33.784	0.997		
34.112	0.997		
34.440	0.998		
34.768	0.998		
35.096	0.998		
35.424	0.998		
35.752	0.998		
36.080	0.999		
36.408	0.999		
36.736	0.999		

Screen Plots

This application generates two plots. These plots may be accessed by selecting the **Plot Data** option (**F2**) from the **Options** menu on the data output screen. The plots generated for the example problem are shown in Figures 3-2-1 and 3-2-2 below. The first plot displayed is the cumulative probability distribution of exceedance (CDF) versus wave height in deep water. The second plot is the CDF versus wave height in water depth of interest. After viewing the first plot, the second plot may be displayed by selecting the **NEXT** option in the graphics package (see Appendix C).

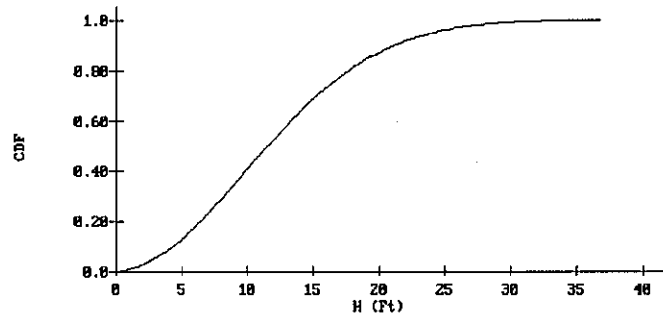

Figure 3-2-1. Wave Height versus Cumulative Probability Distribution of Exceedance (Deep Water)

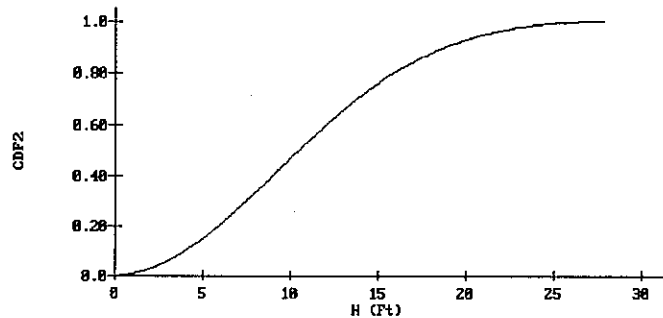

Figure 3-2-2. Wave Height versus Cumulative Probability Distribution of Exceedance (Water Depth = 50 ft)

REFERENCES AND BIBLIOGRAPHY

- Goda, Y. 1975. "Irregular Wave Deformation in the Surf Zone," *Coastal Engineering in Japan*, Vol. 18, pp. 13-26.
- Goda, Y. 1984. *Random Seas and Design of Maritime Structures*, University of Tokyo Press, Tokyo, Japan, pp. 41-46.
- Mitsuyasu, H. 1975. "Observation of the Directional Spectrum of Ocean Waves Using a Cloverleaf Buoy," *Journal of Physical Oceanography*, Vol. 5, No. 4, pp. 750-760.
- Shuto, N. 1974. "Nonlinear Long Waves in a Channel of Variable Section," *Coastal Engineering in Japan*, Vol. 17, pp. 1-12.

COMBINED DIFFRACTION AND REFLECTION BY A VERTICAL WEDGE

TABLE OF CONTENTS

Description	3-3-1
Coordinate System	3-3-1
Procedure	3-3-2
Single Case Mode	3-3-2
Evaluate at a Single Location	3-3-2
Evaluate Upon a Uniform Grid	3-3-4
Plot Output File 1	3-3-5
Multiple Case Mode	3-3-5
Example Problems	3-3-7
Example 1 - Semi-Infinite Breakwater (Single Point)	3-3-7
Input	3-3-7
Output	3-3-7
Example 2 - 90-Deg Wedge (Single Point)	3-3-8
Input	3-3-8
Output	3-3-8
Example 3 - Semi-Infinite Breakwater (Uniform Grid)	3-3-9
Input	3-3-9
Output	3-3-10
Print File or Device	3-3-10
Plot Output File 1	3-3-11
References and Bibliography	3-3-12

COMBINED DIFFRACTION AND REFLECTION BY A VERTICAL WEDGE

DESCRIPTION

This application estimates wave height modification due to combined diffraction and reflection near jettied harbor entrances, quay walls, and other such structures. Jetties and breakwaters are approximated as a single straight, semi-infinite breakwater by setting the wedge angle to zero. Corners of docks and quay walls may be represented by setting the wedge angle equal to 90 deg. Additionally, such natural diffracting and reflecting obstacles as rocky headlands can be approximated by setting a particular value for the wedge angle. Assumptions include monochromatic, linear waves, and constant water depth.

COORDINATE SYSTEM

The coordinate system and terminology used in the diffraction and reflection by a vertical wedge is shown in Figure 3-3-1.

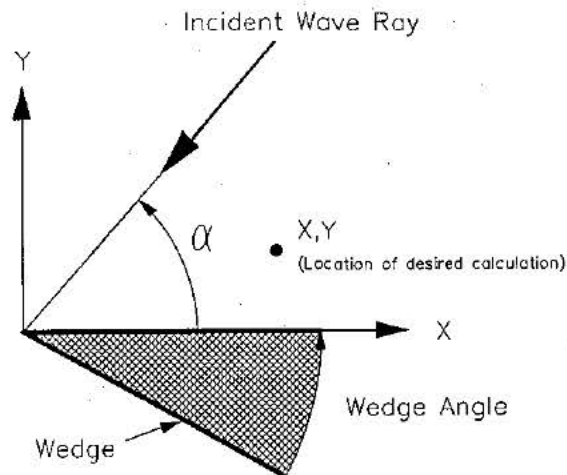

Figure 3-3-1. Diffraction/Reflection by Vertical Wedge System

PROCEDURE

This section provides instructions for running this application in the **Single Case** and **Multiple Case** modes.

Single Case Mode

- Press **F1** on the Main Menu to select Single Case Mode.
- Fill in the highlighted input fields on the General Specifications screen (or leave the default values). Press **F1** when all data on this screen are correct.
- Press **F3** on the Functional Area Menu to select Wave Transformation.
- Press **F3** on the Wave Transformation Application Area Menu to select Combined Diffraction and Reflection by a Vertical Wedge.

In Single Case mode, this application allows two options for calculating a modification factor and modified wave height.

- At a single location.
- Upon a uniform grid.

From the Activity Menu, select either the Single Location or Uniform Grid option. These two options are described below.

F1 Evaluate at a Single Location

All data input for this option is done on one screen. The following list describes the necessary input parameters with their corresponding units and range of data recognized by this application:

<u>Item</u>	<u>Symbol</u>	<u>Units</u>	<u>Data Range</u>
Incident Wave Height	H_i	ft,m	0.1 to 200
Wave Period	T	sec	1 to 1000

Water Depth	d	ft,m	0.01	to	5000
Wave Angle	α	deg	0	to	180
Wedge Angle		deg	0	to	180
X Coordinate	X	ft,m	-5280	to	5280
Y Coordinate	Y	ft,m	-5280	to	5280

NOTE: In practice, the range for X and Y should be limited to plus or minus 10 wavelengths.

When all the data have been entered press, **F1** to begin calculations. When calculations have been completed, all input and output data are displayed on the screen in the selected system of units. Output data include the following parameters:

<u>Item</u>	<u>Symbol</u>	<u>English Units</u>	<u>Metric Units</u>
Wave Length	L	ft	m
Modification Factor (ratio of calculated wave height to incident wave height)	ϕ		
Wave Phase	β	rad	rad
Modified Wave Height	H	ft	m

After data have been displayed, press one of the following keys to select the appropriate action:

- F1** Return to Step 1 for a new case.
- F3** Send a summary of this case to the print file or device.
- F10** Exit this application and return to the Activity Menu.

F2 Evaluate Upon a Uniform Grid

All data input for this option is done on one screen. The following list describes the necessary input parameters with their corresponding units and range of data recognized by this application:

<u>Item</u>	<u>Symbol</u>	<u>Units</u>	<u>Data Range</u>		
Incident Wave Height	H_i	ft,m	0.1	to	200
Wave Period	T	sec	1	to	1000
Water Depth	d	ft,m	0.01	to	5000
Wave Angle	α	deg	0	to	180
Wedge Angle		deg	0	to	180
X Start Coordinate	X_0	ft,m	-5280	to	5280
X End Coordinate	X_m	ft,m	-5280	to	5280
Spatial Increment (X-direction)	ΔX		0.1	to	5280
Y Start Coordinate	Y_0	ft,m	-5280	to	5280
Y End Coordinate	Y_m	ft,m	-5280	to	5280
Spatial Increment (Y-direction)	ΔY		0.1	to	5280

CAUTION: For the application to function properly, the **Start Coordinate** for both the X- and Y-directions **must be less than** the corresponding End Coordinate.

When all the data have been entered, press **F1** to begin calculations. When calculations have been completed, all input and output data are sent to the print file or device and also to plot output file 1 (default name **PLOTDAT1.OUT**). See the section titled Plot Output File 1 for the description and format of the contents of plot output file 1.

After calculations have been completed, press one of the following keys to select the appropriate action:

- F1** Return to Step 1 for a new case.
- F10** Exit this application and return to the Activity Menu.

Plot Output File 1

Plot output file 1 (default name **PLOTDAT1.OUT**) contains the Modification Factors, Modified Wave Heights, and Wave Phase differences between the incident and the modified waves at the grid points defined by the X and Y start and end coordinates. Plot output file 1 is written in the following format (see Table 3-3-2 in Example Problem 3):

Field	Columns	Format	Data
1	1-10	G10.3	X-coordinate
2	11-20	G10.3	Y-coordinate
3	21-30	G10.3	Modified wave height
4	31-40	G10.3	Modification factor
5	41-50	G10.3	Wave phase difference

Multiple Case Mode

- Press **F2** on the Main Menu to select Multi Case Mode.
 - Fill in the highlighted input fields on the General Specifications screen (or leave the default values). Press **F1** when all data on this screen are correct.
 - Press **F3** on the Functional Area Menu to select Wave Transformation.
 - Press **F3** on the Wave Transformation Application Menu to select Combined Diffraction and Reflection by a Vertical Wedge.
1. Move the cursor to select a variable on the Combined Diffraction and Reflection by a Vertical Wedge screen (the selected variable name blinks). The current set of values for the variable is displayed on the right portion of the screen. When all variable sets are correct, go to Step 3.
 2. Enter a set of values for the subject variable by following one of the input methods:

- a. Press **[R]** to select random method. Enter up to 20 values constituting a set for this variable (one in each field) on the right side of the screen. The set of 20 values originally displayed (first execution) in these fields contains the "delimiting" value, which "delimits" or "ends" the set. The "delimiting" value is *not* included as a member in the set unless it is the sole member.
- b. Press **[I]** to select incremental method. Fill in the fields for minimum, maximum, and increment values for this variable on the right side of the screen. In this method, the members of the set include all values from the minimum to the maximum (both inclusive) at the specified increment.

The units field should also be specified for the variable regardless of input method. All members of a set of values for a subject variable are assigned the specified units. When all data are correct for the subject variable, press **[F10]** to return to Step 1. Errors are reported at the bottom of the screen and are corrected by pressing **[F1]** to allow respecification of the data for the subject variable.

3. Press **[F1]** to process the cases resulting from the combinations of the sets of data for all variables. The summary of each case will be sent to the print file or device. The screen will display the total number of cases to be processed as well as report progress. Errors are reported at the bottom of the screen and are corrected by pressing **[F1]** to allow respecification of variable sets.
4. Press one of the following keys to select the appropriate action:
 - [F1]** Return to Step 1 to specify new sets.
 - [F10]** Exit this application and return to the Wave Transformation Application Menu.

EXAMPLE PROBLEMS

Example 1 - Semi-Infinite Breakwater (Single Point)

Input

All data input for this application is done on one screen. The values and corresponding units selected for this first example problem are shown below.

<u>Item</u>	<u>Symbol</u>	<u>Value</u>	<u>Units</u>
Incident Wave Height	H_i	2.0	ft
Wave Period	T	6.0	sec
Water Depth	d	12.0	ft
Wave Angle	α	135.0	deg
Wedge Angle		0.0	deg
X Coordinate	X	35.0	ft
Y Coordinate	Y	-17.0	ft

Output

Results from this application are displayed on one screen. These data include the original input values and the following parameters (see Figure 3-3-2):

<u>Item</u>	<u>Symbol</u>	<u>Value</u>	<u>Units</u>
Wave Length	L	109.82	ft
Modification Factor (ratio of calculated wave height to incident wave height)	ϕ	0.58	
Wave Phase	β	-2.58	rad
Modified Wave Height	H	1.16	ft

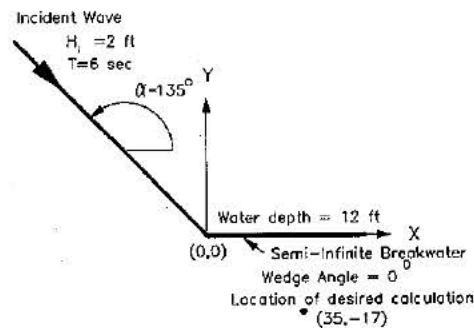

Figure 3-3-2. Semi-Infinite Breakwater Diffraction/Reflection Example Output

Example 2 - 90-Deg Wedge (Single Point)

Input

All data input for this application is done on one screen. The values and corresponding units selected for this second example problem are shown below.

<u>Item</u>	<u>Symbol</u>	<u>Value</u>	<u>Units</u>
Incident Wave Height	H_i	5	m
Wave Period	T	8	sec
Water Depth	d	10	m
Wave Angle	α	47	deg
Wedge Angle		90	deg
X Coordinate	X	-10	m
Y Coordinate	Y	-40	m

Output

Results from this application are displayed on one screen. These data include the original input values and the following parameters (see Figure 3-3-3):

<u>Item</u>	<u>Symbol</u>	<u>Value</u>	<u>Units</u>
Wave Length	L	70.88	m
Modification Factor (ratio of calculated wave height to incident wave height)	ϕ	0.60	
Wave Phase	β	2.12	rad
Modified Wave Height	H	3.01	m

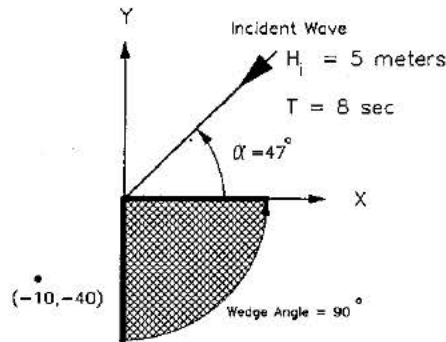

Figure 3-3-3. 90-Deg Wedge Diffraction/Reflection Example Output

Example 3 - Semi-Infinite Breakwater (Uniform Grid)**Input**

All data input for this application is done on one screen. The values and corresponding units selected for this second example problem are shown below (see Figure 3-3-4).

<u>Item</u>	<u>Symbol</u>	<u>Value</u>	<u>Units</u>
Incident Wave Height	H_i	4	ft
Wave Period	T	12	sec
Water Depth	d	30	ft
Wave Angle	α	52	deg
Wedge Angle		0	deg
X Start Coordinate	X_o	-600	ft
X End Coordinate	X_m	200	ft
Spatial Increment (X-direction)	ΔX	200	ft
Y Start Coordinate	Y_o	-400	ft
Y End Coordinate	Y_m	200	ft
Spatial Increment (Y-direction)	ΔY	100	ft

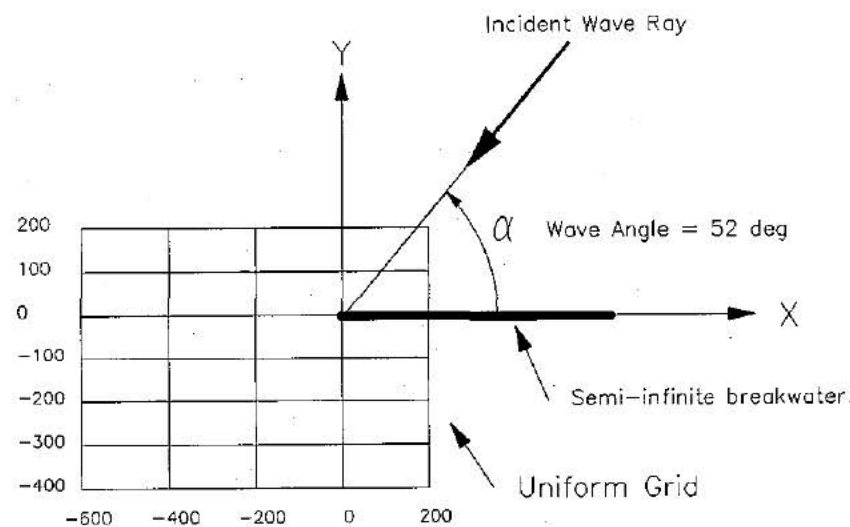

Figure 3-3-4. Semi-Infinite Breakwater Diffraction/Reflection (uniform grid)

Output

Results from this application are sent to the print file or device (see Table 3-3-1) and to plot output file 1 (default name **PLOTDAT1.OUT**) (see Table 3-3-2).

Print File or Device

Table 3-3-1
Combined Reflection and Diffraction by a Vertical Wedge

Incident Wave Height	=	4.00	ft	Wave Period	=	12.00	sec
Water Depth	=	30.00	ft	Wavelength	=	356.85	ft
Wave Angle	=	52.00	deg	Wedge Angle	=	0.00	deg

***** Modification Factors:

	x=	-600.00	-400.00	-200.00	0.00	200.00
y=	200.00	1.00	1.15	1.27	1.67	1.88
y=	100.00	1.04	1.00	0.83	0.74	0.20
y=	0.00	1.00	1.00	1.00	1.00	1.77
y=	-100.00	1.04	1.03	0.86	0.46	0.23
y=	-200.00	1.06	0.93	0.66	0.37	0.22
y=	-300.00	1.00	0.80	0.53	0.32	0.21
y=	-400.00	0.90	0.67	0.44	0.28	0.20
	x=	-600.00	-400.00	-200.00	0.00	200.00

***** Modified Wave Heights (ft):

	x=	-600.00	-400.00	-200.00	0.00	200.00
y=	200.00	4.02	4.59	5.07	6.68	7.52
y=	100.00	4.17	4.00	3.33	2.96	0.81
y=	0.00	4.00	4.00	4.00	4.00	7.08
y=	-100.00	4.17	4.10	3.42	1.84	0.92
y=	-200.00	4.25	3.74	2.66	1.48	0.88
y=	-300.00	4.02	3.19	2.12	1.27	0.84
y=	-400.00	3.61	2.68	1.77	1.14	0.80
	x=	-600.00	-400.00	-200.00	0.00	200.00

***** Phase Angles (rad):

	x=	-600.00	-400.00	-200.00	0.00	200.00
y=	200.00	2.47	-1.60	0.79	-2.97	-1.09
y=	100.00	1.18	-2.87	-0.75	0.52	2.77
y=	0.00	-0.22	1.95	-2.17	0.00	2.18
y=	-100.00	-1.61	0.63	2.82	-2.22	1.64
y=	-200.00	-2.93	-0.68	1.34	2.22	0.60
y=	-300.00	2.04	-2.07	-0.27	0.42	-0.77
y=	-400.00	0.69	2.75	-1.94	-1.37	-2.30
	x=	-600.00	-400.00	-200.00	0.00	200.00

Plot Output File 1

Plot output file 1 (default name **PLOTDAT1.OUT**) contains at grid points defined by the X and Y start and end coordinates the Modified Wave Heights, Modification Factors, and Wave Phase differences between the incident and modified waves. Table 3-3-2 is a listing of plot output file 1 for Example 3.

Table 3-3-2
Listing of Plot Output File 1 for Example Problem 3

Combined Reflection and Diffraction by a Vertical Wedge
Wedge Angle: 0 Incident Wave Angle: 52

ft	ft	ft		rad
-600.	-400.	3.61	0.903	0.690
-400.	-400.	2.68	0.670	2.75
-200.	-400.	1.77	0.442	-1.94
0.000	-400.	1.14	0.285	-1.37
200.	-400.	0.804	0.201	-2.30
-600.	-300.	4.02	1.00	2.04
-400.	-300.	3.19	0.798	-2.07
-200.	-300.	2.12	0.531	-0.273
0.000	-300.	1.27	0.319	0.419
200.	-300.	0.843	0.211	-0.772
-600.	-200.	4.25	1.06	-2.93
-400.	-200.	3.74	0.934	-0.684
-200.	-200.	2.66	0.665	1.34
0.000	-200.	1.48	0.369	2.22
200.	-200.	0.882	0.221	0.599
-600.	-100.	4.17	1.04	-1.61
-400.	-100.	4.10	1.03	0.629
-200.	-100.	3.42	0.856	2.82
0.000	-100.	1.84	0.460	-2.22
200.	-100.	0.916	0.229	1.64
-600.	0.000	4.00	1.00	-0.221
-400.	0.000	4.00	1.00	1.95
-200.	0.000	4.00	1.00	-2.17
0.000	0.000	4.00	1.00	0.000
200.	0.000	7.08	1.77	2.18
-600.	100.	4.17	1.04	1.18
-400.	100.	4.00	1.00	-2.87
-200.	100.	3.33	0.833	-0.754

(Table 3-3-2 Continued on the Next Page)

(Table 3-3-2 Concluded)

0.000	100.	2.96	0.740	0.517
200.	100.	0.809	0.202	2.77
-600.	200.	4.02	1.00	2.47
-400.	200.	4.59	1.15	-1.60
-200.	200.	5.07	1.27	0.787
0.000	200.	6.68	1.67	-2.97
200.	200.	7.52	1.88	-1.09

REFERENCES AND BIBLIOGRAPHY

- Chen, H. S. 1987. "Combined Reflection and Diffraction by a Vertical Wedge," Technical Report CERC-87-16, US Army Engineer Waterways Experiment Station, Vicksburg, MS.
- Chen, H. S., and Thompson, E. F. 1985. "Iterative and Pade Solutions for the Water - Wave Dispersion Relation," Miscellaneous Paper CERC-85-4, US Army Engineer Waterways Experiment Station, Vicksburg, MS.
- Kaihatu, J. A., and Chen, H. S. 1988. "Combined Diffraction and Reflection by a Vertical Wedge: PCDFRAC User's Manual," Technical Report CERC-88-9, US Army Engineer Waterways Experiment Station, Vicksburg, MS.
- Morris, A. H., Jr. 1984. "NSWC Library of Mathematics Subroutines," NSWC TR 84 -143, Strategic Systems Department, Naval Surface Weapons Center, Dahlgren, Va.
- Penny, W. G., and Price, A. T. 1952 "The Diffraction Theory of Sea Waves by Breakwaters, and the Shelter Afforded by Breakwaters", *Philosophical Transactions, Royal Society* (London), Series A, Vol. 244, pp. 236-253
- Stoker, J. J. 1957. *Water Waves*, Interscience Publishers Inc., New York, pp. 109-133.
- Shore Protection Manual*. 1984. 4th ed., 2 Vols., US Army Engineer Waterways Experiment Station, Coastal Engineering Research Center, US Government Printing Office, Washington, DC, Chapter 2, pp. 75-109.
- Wiegel, R. L. 1962. "Diffraction of Waves by a Semi-Infinite Breakwater," *Journal of the Hydraulics Division*, Vol. 88, No. HY1, pp. 27-44.

BREAKWATER DESIGN USING HUDSON AND RELATED EQUATIONS

TABLE OF CONTENTS

Description	4-1-1
Input	4-1-1
Output	4-1-1
Procedure	4-1-2
Single Case Mode	4-1-2
Multiple Case Mode	4-1-3
Example Problem	4-1-4
Input	4-1-4
Output	4-1-4
References and Bibliography	4-1-5

BREAKWATER DESIGN USING HUDSON AND RELATED EQUATIONS

DESCRIPTION

This application provides estimates for the armor weight, minimum crest width, armor thickness, and the number of armor units per unit area of a breakwater using Hudson and related equations.

INPUT

All data input for this application is done on one screen. The following list describes the necessary input parameters with their corresponding units and range of data recognized by this application:

<u>Item</u>	<u>Symbol</u>	<u>Units</u>	<u>Data Range</u>
Armor unit weight	w_r	lb/ft ³ , N/m ³	1.0 to 99999.0
Wave height	H_i	ft, m	0.1 to 100.0
Stability coefficient	K_D		See Table A-1, Appendix A.
Layer coefficient	k_Δ		See Table A-2, Appendix A.
Average porosity of armor layer	P	%	See Table A-2, Appendix A.
Cotangent of structure slope	$\cot\theta$		1.0 to 6.0
Number of armor units comprising the thickness of the armor layer	n		1 to 3

OUTPUT

Results from this application are displayed on one screen. Those data include the original input values (in final units) and the following parameters:

<u>Item</u>	<u>Symbol</u>	<u>English Units</u>	<u>Metric Units</u>
Weight of an individual armor unit	W	lb	N
Crest width of breakwater	B	ft	m
Average cover layer thickness	r	ft	m
Number of single armor units per unit surface area	N_r		

PROCEDURE

The bulleted items in the following lists indicate potentially optional instruction steps. Any application in ACES may be executed in a given session without quitting the program. The bulleted items provide instructions for accessing the application from various menu areas of the ACES program. Ignore bulleted instruction steps that are not applicable.

Single Case Mode

- Press **F1** on the Main Menu to select Single Case Mode.
 - Fill in the highlighted input fields on the General Specifications screen (or leave the default values). Press **F1** when all data on this screen are correct.
 - Press **F4** on the Functional Area Menu to select Wave - Structure Interaction.
 - Press **F1** on the Structural Design Menu to select Breakwater Design Using Hudson and Related Equations.
1. Fill in the highlighted input fields on the screen. Respond to any corrective instructions appearing at the bottom of the screens. Press **F1** when all data on this screen are correct or **F10** to provide access to the additional following options (choose one):
 - F1** Return to the input screen.
 - F3** Display tables of suggested K_D values.
 - F4** Display a table of suggested values for P and k_Δ .
 - F10** Exit application.
 2. All output data and selected input data are displayed on the screen in the final system of units.
 3. Press one of the following keys to select the appropriate action:
 - F1** Return to Step 1 for a new case.
 - F3** Send a summary of this case to the print file or device.
 - F10** Exit this application and return to the Structural Design Menu.

Multiple Case Mode

- Press **F2** on the Main Menu to select Multi Case Mode.
 - Fill in the highlighted input fields on the General Specifications screen (or leave the default values). Press **F1** when all data on this screen are correct.
 - Press **F4** on the Functional Area Menu to select Structural Design.
 - Press **F1** on the Structural Design Menu to select Breakwater Design Using Hudson and Related Equations.
1. Move the cursor to select a variable on the Breakwater Design Using Hudson and Related Equations screen (the selected variable name blinks). The current set of values for the variable is displayed on the right portion of the screen. When all variable sets are correct, go to Step 3.
 2. Enter a set of values for the subject variable by following one of the input methods:
 - a. Press **R** to select random method. Enter up to 20 values constituting a set for this variable (one in each field) on the right side of the screen. The set of 20 values originally displayed (first execution) in these fields contains the "delimiting" value, which "delimits" or "ends" the set. The "delimiting" value is *not* included as a member in the set unless it is the sole member.
 - b. Press **I** to select incremental method. Fill in the fields for minimum, maximum, and increment values for this variable on the right side of the screen. In this method, the members of the set include all values from the minimum to the maximum (both inclusive) at the specified increment.

The units field should also be specified for the variable regardless of input method. All members of a set of values for a subject variable are assigned the specified units. When all data are correct for the subject variable, press **F10** to return to Step 1. Errors are reported at the bottom of the screen and are corrected by pressing **F1** to allow respecification of the data for the subject variable.
 3. Press **F1** to process the cases resulting from the combinations of the sets of data for all variables. The summary of each case will be sent to the print file or device. The screen will display the total number of cases to be processed as well as report progress. Errors are reported at the bottom of the screen and are corrected by pressing **F1** to allow respecification of variable sets.
 4. Press one of the following keys to select the appropriate action:
 - F1** Return to Step 1 to specify new sets.
 - F10** Exit this application and return to the Structural Design Menu.

EXAMPLE PROBLEM**Input**

All data input for this application is done on one screen. The values and corresponding units selected for this example problem are shown below.

Type of Armor Unit: Tribar, nonbreaking wave on structure trunk [Optional Input]

<u>Item</u>	<u>Symbol</u>	<u>Value</u>	<u>Units</u>
Armor unit weight	w_r	165.00	lb/ft ³
Wave height	H_i	11.50	ft
Stability coefficient	K_D	10.00	
Layer coefficient	k_Δ	1.02	
Average porosity of armor layer	P	54.00	%
Cotangent of structure slope	$\cot\theta$	2.00	
Number of armor units comprising the thickness of the armor layer	n	2	

Output

Results from this application are displayed on one screen. These data include the original input values and the following parameters:

<u>Item</u>	<u>Symbol</u>	<u>Value</u>	<u>Units</u>
Weight of an individual armor unit	W	1.59	tons
Crest width of breakwater	B	8.21	ft
Average cover layer thickness	r	5.47	ft
Number of single armor units per unit surface area	N_r	130.30	

REFERENCES AND BIBLIOGRAPHY

- Headquarters, Department of the Army. 1986. "Design of Breakwaters and Jetties," Engineer Manual 1110-2-2904, Washington, DC, p. 4-10.
- Hudson, R. Y. 1953. "Wave Forces on Breakwaters," *Transactions of the American Society of Civil Engineers*, American Society of Civil Engineers, Vol. 118, p. 653.
- Hudson, R. Y. 1959. "Laboratory Investigations of Rubble-Mound Breakwaters," *Proceedings of the American Society of Civil Engineers*, American Society of Civil Engineers, Waterways and Harbors Division, Vol. 85, NO. WW3, Paper No. 2171.
- Hudson, R. Y. 1961a. "Laboratory Investigation of Rubble-Mound Breakwaters," *Transactions of the American Society of Civil Engineers*, American Society of Civil Engineers, Vol. 126, Pt IV.
- Hudson, R. Y. 1961b. "Wave Forces on Rubble-Mound Breakwaters and Jetties," Miscellaneous Paper 2-453, US Army Engineer Waterways Experiment Station, Vicksburg, MS.
- Markel, D. G., and Davidson, D. D. 1979. "Placed-Stone Stability Tests, Tillamook, Oregon; Hydraulic Model Investigation," Technical Report HL-79-16, US Army Engineer Waterways Experiment Station, Vicksburg, MS.
- Shore Protection Manual*. 1984. 4th ed., 2 Vols., US Army Engineer Waterways Experiment Station, Coastal Engineering Research Center, US Government Printing Office, Washington, DC, Chapter 7, pp. 202-242.
- Smith, O. P. 1986. "Cost-Effective Optimization of Rubble-Mound Breakwater Cross Sections," Technical Report CERC-86-2, US Army Engineer Waterways Experiment Station, Vicksburg, MS, p. 48.
- Zwamborn, J. A., and Van Niekerk, M. 1982. *Additional Model Tests--Dolos Packing Density and Effect of Relative Block Density*, CSIR Research Report 554, Council for Scientific and Industrial Research, National Research Institute for Oceanology, Coastal Engineering and Hydraulics Division, Stellenbosch, South Africa.

TOE PROTECTION DESIGN

TABLE OF CONTENTS

Description	4-2-1
Input	4-2-1
Output	4-2-2
Procedure	4-2-3
Single Case Mode	4-2-3
Multiple Case Mode	4-2-3
Example Problems	4-2-5
Example 1 - Toe Protection for a Bulkhead	4-2-5
Input	4-2-5
Output	4-2-5
Example 2 - Toe Protection for a Vertical Breakwater	4-2-6
Input	4-2-6
Output	4-2-6
References and Bibliography	4-2-7

TOE PROTECTION DESIGN

DESCRIPTION

Toe protection consists of armor for the beach or bottom material fronting a structure to prevent wave scour. This application determines armor stone size and width of a toe protection apron for *vertical* faced structures such as seawalls, bulkheads, quay walls, breakwaters, and groins. Apron width is determined by the geotechnical and hydraulic guidelines specified in Engineer Manual 1110-2-1614. Stone size is determined by a method (Tanimoto, Yagyu, and Goda, 1982) whereby a stability equation is applied to a single rubble unit placed at a position equal to the width of the toe apron and subjected to standing waves.

INPUT

The terminology and symbols used in this application are shown in Figures 4-2-1 and 4-2-2.

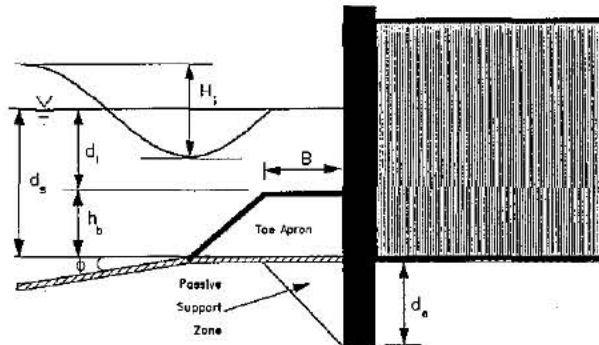

Figure 4-2-1. Typical Toe Apron for Sheet-Pile Walls

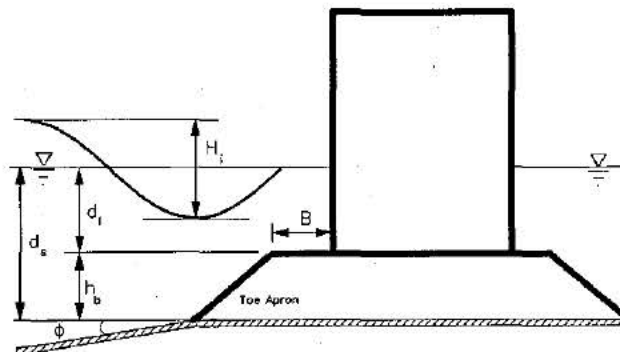

Figure 4-2-2. Typical Apron for Breakwaters

All data input for this application is done on one screen. The following list describes the necessary input parameters with their corresponding units and range of data recognized by this application:

<u>Item</u>	<u>Symbol</u>	<u>Units</u>	<u>Data Range</u>	
Incident wave height	H_i	ft, m	0.1	to 100.0
Wave period	T	sec	1.0	to 1000.0
Water depth at structure	d_s	ft, m	0.1	to 200.0
Cotangent of nearshore slope	$\cot\phi$		5.0	to 10000.0
Passive earth pressure coefficient	K_p		0.0	to 50.0
Sheet-pile penetration depth	d_e	ft, m	0.0	to 200.0
NOTE: For structures without sheet piles, the values of K_p and d_e should be set to 0.0.				
Height of toe protection layer above mudline	h_b	ft, m	0.1	to 200.0
Unit weight of rock	w_r	lb/ft ³ , N/m ³	1.0	to 99999.0

OUTPUT

Results from this application are displayed on one screen. Those data include the original input values (in final units) and the following parameters:

<u>Item</u>	<u>Symbol</u>	<u>English Units</u>	<u>Metric Units</u>
Width of toe protection apron	B	ft	m
Weight of individual armor unit	W	lb	N
Water depth at top of toe protection layer	d_1	ft	m

PROCEDURE

The bulleted items in the following lists indicate potentially optional instruction steps. Any application in ACES may be executed in a given session without quitting the program. The bulleted items provide instructions for accessing the application from various menu areas of the ACES program. Ignore bulleted instruction steps that are not applicable.

Single Case Mode

- Press **(F1)** on the Main Menu to select Single Case Mode.
 - Fill in the highlighted input fields on the General Specifications screen (or leave the default values). Press **(F1)** when all data on this screen are correct.
 - Press **(F4)** on the Functional Area Menu to select Structural Design.
 - Press **(F2)** on the Structural Design Menu to select Toe Protection Design.
1. Fill in the highlighted input fields on the screen. Respond to any corrective instructions appearing at the bottom of the screens. Press **(F1)** when all data on this screen are correct.
 2. All output data and selected input data are displayed on the screen in the final system of units.
 3. Press one of the following keys to select the appropriate action:
 - (F1)** Return to Step 1 for a new case.
 - (F3)** Send a summary of this case to the print file or device.
 - (F10)** Exit this application and return to the Structural Design Menu.

Multiple Case Mode

- Press **(F2)** on the Main Menu to select Multi Case Mode.
- Fill in the highlighted input fields on the General Specifications screen (or leave the default values). Press **(F1)** when all data on this screen are correct.
- Press **(F4)** on the Functional Area Menu to select Structural Design.
- Press **(F2)** on the Structural Design Menu to select Toe Protection Design.

1. Move the cursor to select a variable on the Toe Protection Design screen (the selected variable name blinks). The current set of values for the variable is displayed on the right portion of the screen. When all variable sets are correct, go to Step 3.
2. Enter a set of values for the subject variable by following one of the input methods:
 - a. Press **(R)** to select random method. Enter up to 20 values constituting a set for this variable (one in each field) on the right side of the screen. The set of 20 values originally displayed (first execution) in these fields contains the "delimiting" value, which "delimits" or "ends" the set. The "delimiting" value is *not* included as a member in the set unless it is the sole member.
 - b. Press **(I)** to select incremental method. Fill in the fields for minimum, maximum, and increment values for this variable on the right side of the screen. In this method, the members of the set include all values from the minimum to the maximum (both inclusive) at the specified increment.

The units field should also be specified for the variable regardless of input method. All members of a set of values for a subject variable are assigned the specified units. When all data are correct for the subject variable, press **(F10)** to return to Step 1. Errors are reported at the bottom of the screen and are corrected by pressing **(F1)** to allow respecification of the data for the subject variable.

3. Press **(F1)** to process the cases resulting from the combinations of the sets of data for all variables. The summary of each case will be sent to the print file or device. The screen will display the total number of cases to be processed as well as report progress. Errors are reported at the bottom of the screen and are corrected by pressing **(F1)** to allow respecification of variable sets.
4. Press one of the following keys to select the appropriate action:
 - (F1)** Return to Step 1 to specify new sets.
 - (F10)** Exit this application and return to the Structural Design Menu.

EXAMPLE PROBLEMS

Example 1 - Toe Protection for a Bulkhead

Input

All data input for this application is done on one screen. The values and corresponding units selected for this first example problem are shown below.

<u>Item</u>	<u>Symbol</u>	<u>Value</u>	<u>Units</u>
Incident wave height	H_i	5.00	ft
Wave period	T	12.00	sec
Water depth at structure	d_s	20.00	ft
Cotangent of nearshore slope	$\cot\phi$	100.00	
Passive earth pressure coefficient	K_p	1.50	
Sheet-pile penetration depth	d_e	10.00	ft
Height of toe protection layer above mudline	h_b	4.50	ft
Unit weight of rock	w_r	165.00	lb/ft ³

Output

Results from this application are displayed on one screen. Those data include the original input values and the following parameters (see Figure 4-2-3 for location of parameters):

<u>Item</u>	<u>Symbol</u>	<u>Value</u>	<u>Units</u>
Width of toe protection apron	B	15.00	ft
Weight of individual armor unit	W	12.99	lb
Water depth at top of toe protection layer	d_1	15.50	ft

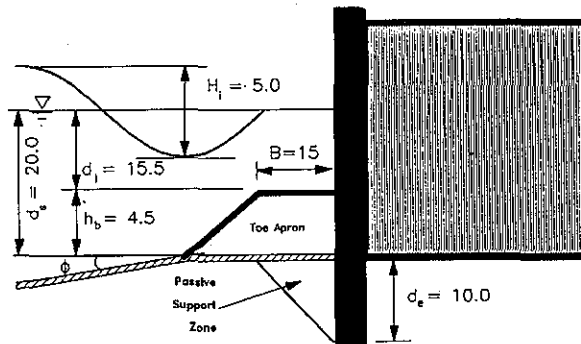

Figure 4-2-3. Toe Protection for Bulkhead Example Output

Example 2 - Toe Protection for a Vertical Breakwater

Input

All data input for this application is done on one screen. The values and corresponding units selected for this example problem are shown below.

<u>Item</u>	<u>Symbol</u>	<u>Value</u>	<u>Units</u>
Incident wave height	H_i	5.00	ft
Wave period	T	12.00	sec
Water depth at structure	d_s	20.00	ft
Cotangent of nearshore slope	$\cot\phi$	100.00	
Passive earth pressure coefficient	K_p	0.00	
Sheet-pile penetration depth	d_e	0.00	
Height of toe protection layer above mudline	h_b	4.50	ft
Unit weight of rock	w_r	165.00	lb/ft ³

Output

Results from this application are displayed on one screen. Those data include the original input values and the following parameters (see Figure 4-2-4 for location of parameters):

<u>Item</u>	<u>Symbol</u>	<u>Value</u>	<u>Units</u>
Width of toe protection apron	B	10.00	ft
Weight of individual armor unit	W	4.836	lb
Water depth at top of toe protection layer	d_t	15.50	ft

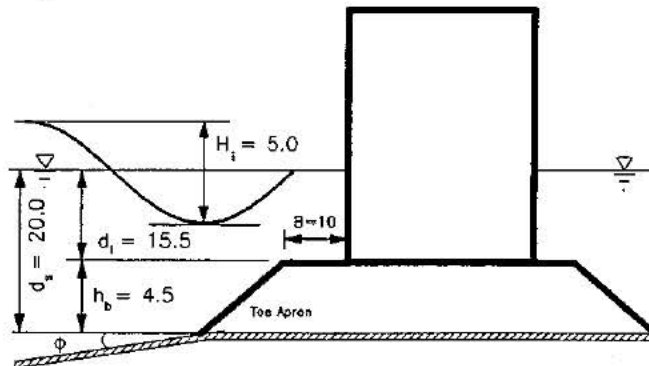

Figure 4-2-4. Toe Protection for Vertical Breakwater Example Output

REFERENCES AND BIBLIOGRAPHY

- Eckert, J. W. 1983. "Design of Toe Protection for Coastal Structures," *Proceedings of the Coastal Structures '83 Conference*, American Society of Civil Engineers, Arlington, VA, pp. 331-341.
- Eckert, J. W., and Callendar, G. 1987. "Geotechnical Engineering in the Coastal Zone," Instructional Report CERC-87-1, US Army Engineer Waterways Experiment Station, Vicksburg, MS, Chapter 8, pp. 36-38.
- Headquarters, Department of the Army. 1985. "Design of Coastal Revetments, Seawalls, and Bulkheads," Engineer Manual 1110-2-1614, Washington, DC, Chapter 2, pp. 15-19.
- Hudson, R. Y. 1959. "Laboratory Investigations of Rubble-Mound Breakwaters," *Proceedings of the American Society of Civil Engineers*, American Society of Civil Engineers, Waterways and Harbors Division, Vol. 85, NO. WW3, Paper No. 2171.
- Shore Protection Manual*. 1984. 4th ed., 2 Vols., US Army Engineer Waterways Experiment Station, Coastal Engineering Research Center, US Government Printing Office, Washington, DC, Chapter 7, pp. 242-249.
- Tanimoto, K., Yagyu, T., and Goda, Y. 1982. "Irregular Wave Tests for Composite Breakwater Foundations," *Proceedings of the 18th Coastal Engineering Conference*, American Society of Civil Engineers, Cape Town, Republic of South Africa, Vol. III, pp. 2144-2161.

NONBREAKING WAVE FORCES AT VERTICAL WALLS

TABLE OF CONTENTS

Description	4-3-1
Input	4-3-1
Output	4-3-2
Screen Output	4-3-2
Plot Output File 1	4-3-3
Screen Plots	4-3-3
Procedure	4-3-3
Single Case Mode	4-3-3
Multiple Case Mode	4-3-4
Example Problem	4-3-6
Input	4-3-6
Output	4-3-6
Screen Output	4-3-6
Plot Output File 1	4-3-7
Screen Plot	4-3-10
References and Bibliography	4-3-12

NONBREAKING WAVE FORCES AT VERTICAL WALLS

DESCRIPTION

This application provides the pressure distribution and resultant force and moment loading on a vertical wall caused by normally incident, *nonbreaking*, regular waves as proposed by Sainflou (1928), Miche (1944), and Rundgren (1958). The results can be used to design vertical structures in protected or fetch-limited regions when the water depth at the structure is greater than about 1.5 times the maximum expected wave height. Both the Sainflou and Miche-Rundgren theories are used by this application to determine wave-induced pressure distribution on a vertical wall. Sainflou's theory is more appropriate for measuring results of long, nonbreaking waves of low steepness, but it overpredicts as the waves become steeper. The Miche-Rundgren theory provides more accurate results for steep, nonbreaking waves, but the theory begins to overpredict as the wavelength is increased. Given wave properties and a wave reflection coefficient, this application presents results of each theory with a recommendation of using results from the theory giving lower values for force and moment. This application provides the same results as found using the design curves given in Chapter 7 of the SPM (1984).

INPUT

The terminology used to define wave forces at vertical walls is shown in Figure 4-3-1.

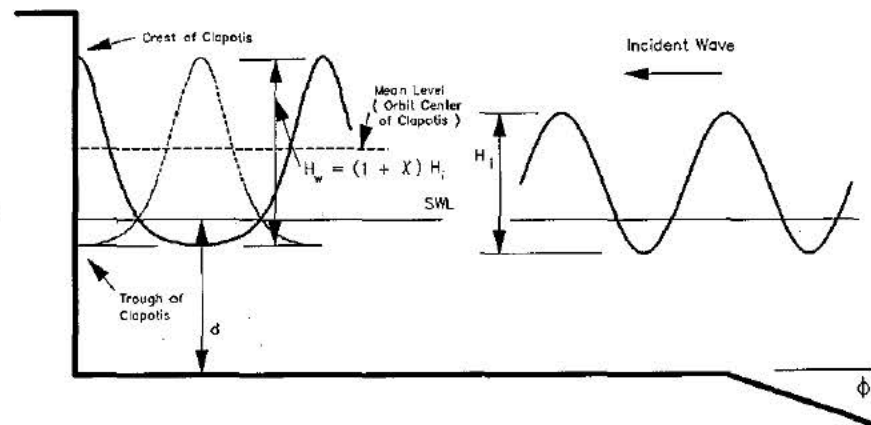

Figure 4-3-1. Nonbreaking Waves at Vertical Walls

All data input for this application is done on one screen. The following list describes the necessary input parameters with their corresponding units and range of data recognized by this application:

<u>Item</u>	<u>Symbol</u>	<u>Units</u>	<u>Data Range</u>	
Depth for SWL	d	ft, m	0.1	to 200.0
Incident wave height	H_i	ft, m	0.1	to 100.0
Wave period	T	sec	1.0	to 100.0
Wave reflection coefficient	χ		0.9	to 1.0
Cotangent of nearshore slope	$\cot \phi$		5.0	to 10000.0

OUTPUT

Results from this application are displayed on one screen. In addition, there is an option (available in Single Case Mode only) to send data to a plot output file (default name **PLOTDAT1.OUT**). This application also generates four screen plots. Each of these outputs is described below.

Screen Output

Results from this application are displayed on one screen. Those data includes the original input values (in final units) and the following parameters at the wave *crest* and *trough* for both the *Miche-Rundgren* and *Sainflou* methods:

<u>Item</u>	<u>Symbol</u>	<u>English Units</u>	<u>Metric Units</u>
Wave crest and trough positions at wall (measured from the bottom)		ft	m
Integrated wave force		lb/ft	n/m
Integrated moment about base		lb-ft/ft	n-m/m

Also displayed on the screen is a recommendation to use results from the method yielding the lower values for force and moment.

Plot Output File 1

Plot output file 1 contains the Miche-Rundgren and Sainflou pressure distribution for both the wave crest and trough at the wall and is written in the following format (see Table 4-3-1 in the example problem):

Field	Columns	Format	Data
1	1-3	I3	Point Counter
2	5-14	F10.2	Elevation
3	19-28	F10.2	Wave Pressure
4	33-42	F10.2	Hydrostatic Pressure
5	50-59	F10.2	Wave and Hydrostatic Pressure

Screen Plots

This application generates four plots showing pressure distribution for both the Miche-Rundgren and Sainflou methods with the wave crest and trough at the wall. Three curves per plot are plotted including the individual wave and hydrostatic pressure and the sum of the wave and hydrostatic pressure (see Figures 4-3-2 through 4-3-5 in the example problem).

PROCEDURE

The bulleted items in the following lists indicate potentially optional instruction steps. Any application in ACES may be executed in a given session without quitting the program. The bulleted items provide instructions for accessing the application from various menu areas of the ACES program. Ignore bulleted instruction steps that are not applicable.

Single Case Mode

- Press **F1** on the Main Menu to select Single Case Mode.
- Fill in the highlighted input fields on the General Specifications screen (or leave the default values). Press **F1** when all data on this screen are correct.
- Press **F4** on the Functional Area Menu to select Structural Design.

- Press **F3** on the Structural Design Menu to select Nonbreaking Wave Forces at Vertical Walls.
1. Fill in the highlighted input fields on the Nonbreaking Wave Forces at Vertical Walls screen. Respond to any corrective instructions appearing at the bottom of the screen. Press **F1** when all data on this screen are correct.
 2. All input and output data are displayed on the screen in the final system of units.
 3. Press one of the following keys to select the appropriate action:
 - F1** Return to Step 1 for a new case.
 - F2** Plot pressure data.
 - F3** Send a summary of this case to the print file or device.
 - F4** Generate a file containing the plot data (Plot Output File 1).
 - F10** Exit this application and return to the Structural Design Menu.

Multiple Case Mode

- Press **F2** on the Main Menu to select Multi Case Mode.
 - Fill in the highlighted input fields on the General Specifications screen (or leave the default values). Press **F1** when all data on this screen are correct.
 - Press **F4** on the Functional Area Menu to select Structural Design.
 - Press **F3** on the Structural Design Menu to select Nonbreaking Wave Forces at Vertical Walls.
1. Press **F1** to enter Multi Case data entry mode.
 2. Move the cursor to select a variable on the Nonbreaking Wave Forces at Vertical Walls screen (the selected variable name blinks). The current set of values for the variable is displayed on the right portion of the screen. When all variable sets are correct, go to Step 3.
 3. Enter a set of values for the subject variable by following one of the input methods:
 - a. Press **R** to select random method. Enter up to 20 values constituting a set for this variable (one in each field) on the right side of the screen. The set of 20 values originally displayed (first execution) in these fields

contains the "delimiting" value, which "delimits" or "ends" the set. The "delimiting" value is *not* included as a member in the set unless it is the sole member.

- b. Press **I** to select incremental method. Fill in the fields for minimum, maximum, and increment values for this variable on the right side of the screen. In this method, the members of the set include all values from the minimum to the maximum (both inclusive) at the specified increment.

The units field should also be specified for the variable regardless of input method. All members of a set of values for a subject variable are assigned the specified units. When all data are correct for the subject variable, press **F10** to return to Step 1. Errors are reported at the bottom of the screen and are corrected by pressing **F1** to allow respecification of the data for the subject variable.

4. Press **F1** to process the cases resulting from the combinations of the sets of data for all variables. The summary of each case will be sent to the print file or device. The screen will display the total number of cases to be processed as well as report progress. Errors are reported at the bottom of the screen and are corrected by pressing **F1** to allow respecification of variable sets.
5. Press one of the following keys to select the appropriate action:

- F1** Return to Step 1 to specify new sets.
- F10** Exit this application and return to the Structural Design Menu.

NOTE: Multiple Case Mode does not generate any plot output files or plots.

EXAMPLE PROBLEM

Input

All data input for this application is done on one screen. The values and corresponding units selected for this example problem are shown below.

<u>Item</u>	<u>Symbol</u>	<u>Value</u>	<u>Units</u>
Depth for SWL	d	15.0	ft
Incident wave height	H_i	8.0	ft
Wave period	T	10.0	sec
Wave reflection coefficient	χ	1.0	
Cotangent of nearshore slope	$\cot\phi$	100.0	

Output

Results from this application are displayed on one screen and, if requested (in Single Case only), written to plot output file 1. In addition, four plots are generated. Each of these outputs for the example problem is presented below.

Screen Output

Results from this application are displayed on one screen. Those data include the original input values and the following parameters:

Wave Position at Wall	MICHE-RUNDGREN		SAINFLOU		Units
	Crest	Trough	Crest	Trough	
Hgt above Bottom	32.95	16.95	32.95	16.95	ft
Integrated Force	28683.39	7121.92	17724.17	2323.04	lb/ft
Integrated Moment about Base	306958.40	38825.47	148008.60	7214.73	lb-ft/ft

NOTE: Sainflou results are recommended for this case.

Plot Output File 1

Table 4-3-1 below is a partial listing of plot output file 1 (default name **PLOTDAT1.OUT**) generated by this application for the example problem.

Table 4-3-1
Partial Listing of Plot Output File 1 for Example Problem

Miche-Rundgren Pressure Distribution
Crest at Wall (Figure 4-3-2)

	Elevation (ft)	Wave Pressure (lb/ft ²)	Hydrostatic Pressure (lb/ft ²)	Wave & Hydrostatic Pressure (lb/ft ²)
1	-15.00	871.49	959.79	1831.28
2	-14.65	871.52	937.40	1808.92
3	-14.30	871.62	915.00	1786.62
4	-13.95	871.78	892.60	1764.38
5	-13.60	872.01	870.20	1742.21
6	-13.25	872.30	847.79	1720.09
7	-12.90	872.65	825.39	1698.04
8	-12.55	873.07	802.97	1676.05
9	-12.20	873.56	780.56	1654.12
↓	↓	↓	↓	↓
83	14.79	152.88	0.00	152.88
84	15.18	133.71	0.00	133.71
85	15.57	114.56	0.00	114.56
86	15.96	95.43	0.00	95.43
87	16.36	76.31	0.00	76.31
88	16.75	57.21	0.00	57.21
89	17.15	38.13	0.00	38.13
90	17.55	19.06	0.00	19.06
91	17.95	0.00	0.00	0.00

(Table 4-3-1 Continued on the Next Page)

(Table 4-3-1 Continued)
 Miche-Rundgren Pressure Distribution
 Trough at Wall (Figure 4-3-3)

	Elevation (ft)	Wave Pressure (lb/ft ²)	Hydrostatic Pressure (lb/ft ²)	Wave & Hydrostatic Pressure (lb/ft ²)
1	-15.00	-465.53	959.79	494.26
2	-14.82	-459.31	948.41	489.10
3	-14.64	-453.10	937.02	483.92
4	-14.47	-446.90	925.64	478.74
5	-14.29	-440.71	914.25	473.54
6	-14.11	-434.53	902.86	468.33
7	-13.93	-428.35	891.47	463.11
8	-13.75	-422.19	880.07	457.89
9	-13.58	-416.03	868.68	452.65
↓	↓	↓	↓	↓
83	0.29	45.25	0.00	45.25
84	0.50	39.59	0.00	39.59
85	0.70	33.94	0.00	33.94
86	0.91	28.28	0.00	28.28
87	1.11	22.63	0.00	22.63
88	1.32	16.97	0.00	16.97
89	1.53	11.31	0.00	11.31
90	1.74	5.66	0.00	5.66
91	1.95	0.00	0.00	0.00

Sainflou Pressure Distribution
 Crest at Wall (Figure 4-3-4)

	Elevation (ft)	Wave Pressure (lb/ft ²)	Hydrostatic Pressure (lb/ft ²)	Wave & Hydrostatic Pressure (lb/ft ²)
1	-15.00	465.53	959.79	1425.32
2	-14.73	466.96	942.20	1409.16

(Table 4-3-1 Continued on the Next Page)

(Table 4-3-1 Continued)

3	-14.45	468.40	924.61	1393.00
4	-14.18	469.85	907.02	1376.86
5	-13.90	471.31	889.42	1360.73
6	-13.63	472.78	871.83	1344.61
7	-13.35	474.27	854.23	1328.50
8	-13.08	475.76	836.63	1312.40
9	-12.80	477.27	819.03	1296.31
↓	↓	↓	↓	↓
83	7.94	125.38	0.00	125.38
84	8.23	109.71	0.00	109.71
85	8.52	94.03	0.00	94.03
86	8.81	78.36	0.00	78.36
87	9.10	62.69	0.00	62.69
88	9.39	47.02	0.00	47.02
89	9.69	31.34	0.00	31.34
90	9.98	15.67	0.00	15.67
91	17.95	0.00	0.00	0.00

Sainflou Pressure Distribution
Trough at Wall (Figure 4-3-5)

	Elevation (ft)	Wave Pressure (lb/ft ²)	Hydrostatic Pressure (lb/ft ²)	Wave & Hydrostatic Pressure (lb/ft ²)
1	-15.00	-465.53	959.79	494.26
2	-14.90	-464.11	953.21	489.10
3	-14.79	-462.71	946.63	483.92
4	-14.69	-461.32	940.05	478.74
5	-14.59	-459.93	933.47	473.54
6	-14.49	-458.56	926.89	468.33
7	-14.38	-457.20	920.31	463.11
8	-14.28	-455.85	913.73	457.89
9	-14.18	-454.51	907.15	452.65
↓	↓	↓	↓	↓

(Table 4-3-1 Continued on the Next Page)

(Table 4-3-1 Concluded)

83	-6.56	-374.30	419.54	45.25
84	-6.45	-373.33	412.93	39.59
85	-6.35	-372.37	406.31	33.94
86	-6.25	-371.41	399.69	28.28
87	-6.14	-370.45	393.07	22.63
88	-6.04	-369.48	386.45	16.97
89	-5.94	-368.52	379.83	11.31
90	-5.83	-367.55	373.21	5.66
91	1.95	0.00	0.00	0.00

Screen Plot

This application generates four plots. The plots may be accessed from the **Nonbreaking Wave Forces on Vertical Walls Plot Selection Menu**, which appears when the **Plot Pressure Data** option (F2) from the input screen is requested. To access a plot, move the cursor (using the arrow keys) to the desired plot and press (F1). (Appendix C describes options to customize plots.) The plots generated for this example problem are shown below.

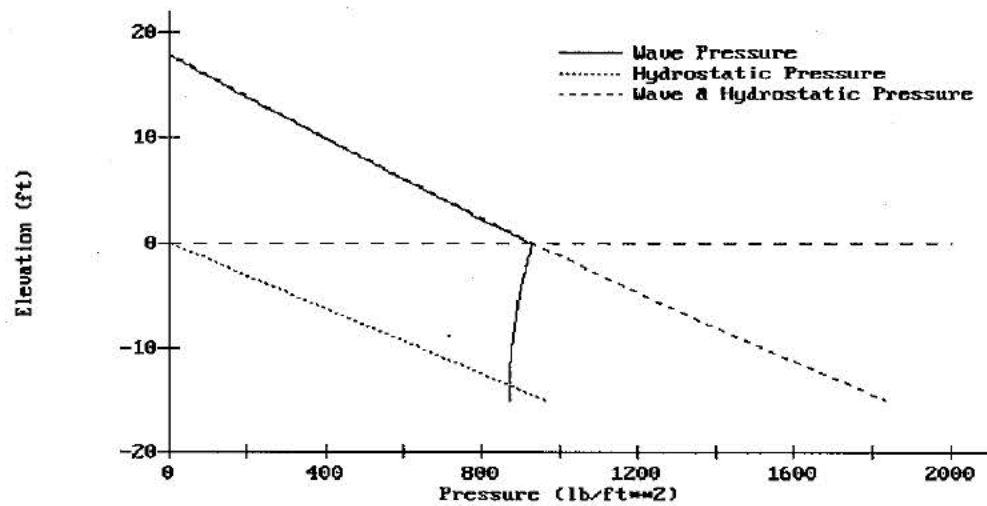
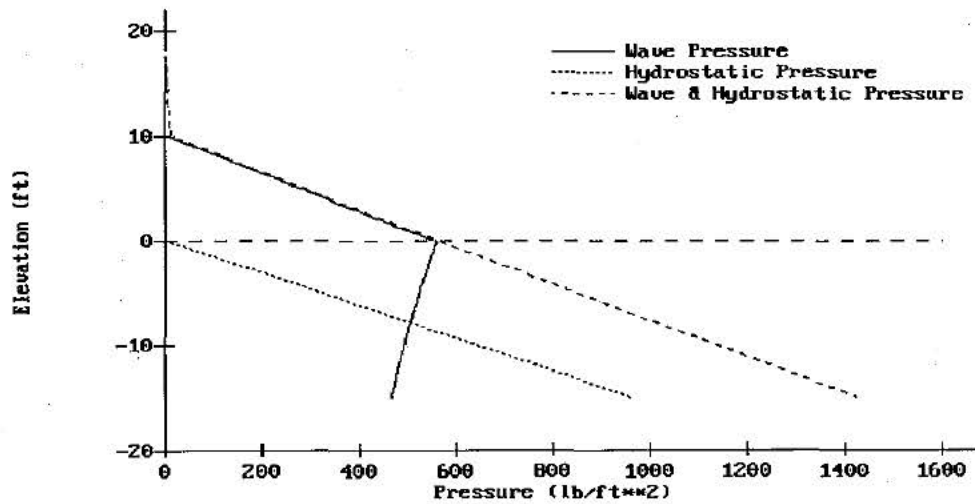
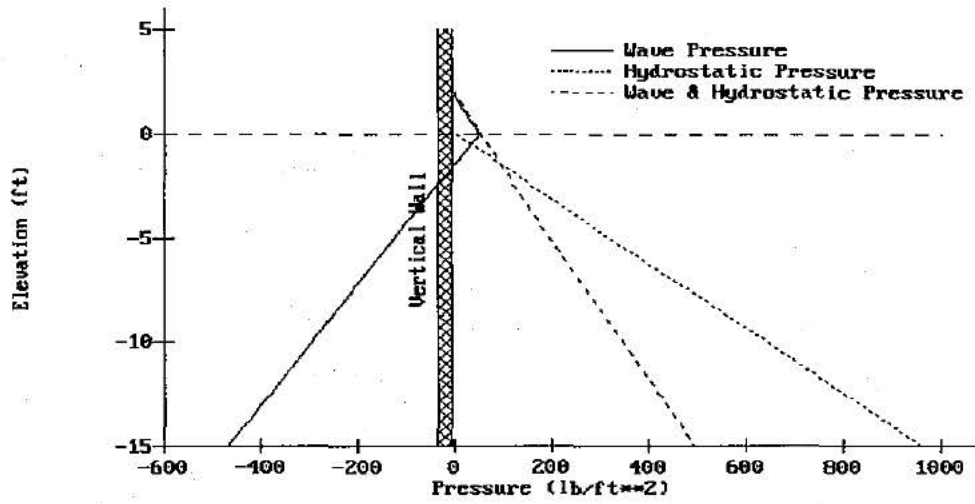

Figure 4-3-2. Miche-Rundgren Pressure Distribution - Crest at Wall



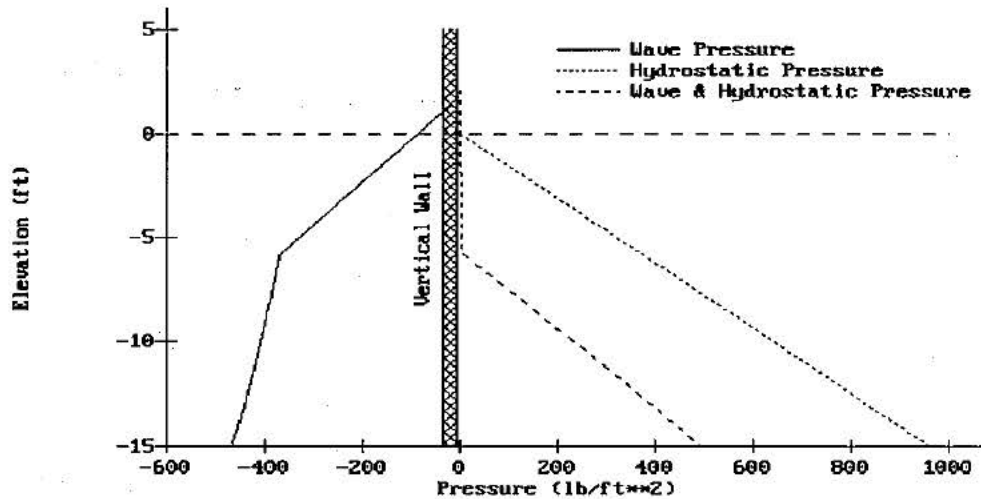

Figure 4-3-5. Sainflou Pressure Distribution - Trough at Wall

REFERENCES AND BIBLIOGRAPHY

- Miche, R. 1944. "Mouvements ondulatoires de la mer en profondeur constante ou décroissante," *Annales des Ponts et Chaussées*, Paris, Vol. 114.
- Rundgren, L. 1958. "Water Wave Forces," Bulletin No. 54, Royal Institute of Technology, Division of Hydraulics, Stockholm, Sweden.
- Sainflou, M. 1928. "Essay on Vertical Breakwaters," *Annals des Ponts et Chaussées*, Paris (Translated by Clarence R. Hatch, Western Reserve University, Cleveland, OH).
- Shore Protection Manual*. 1984. 4th ed., 2 Vols., US Army Engineer Waterways Experiment Station, Coastal Engineering Research Center, US Government Printing Office, Washington, DC, Chapter 7, pp. 161-173.

RUBBLE-MOUND REVETMENT DESIGN

TABLE OF CONTENTS

Description	4-4-1
Input	4-4-1
Output	4-4-1
Procedure	4-4-2
Single Case Mode	4-4-2
Multiple Case Mode	4-4-2
Example Problem	4-4-4
Input	4-4-4
Output	4-4-4
References and Bibliography	4-4-5

RUBBLE-MOUND REVETMENT DESIGN

DESCRIPTION

Quarystone is the most commonly used material for protecting earth embankments from wave attack because, where available, high-quality stone provides a stable and unusually durable revetment armor material at relatively low cost. This ACES application provides estimates for revetment armor and bedding layer stone sizes, thicknesses, and gradation characteristics. Also calculated are two values of runoff on the revetment, an expected extreme and a conservative runoff value.

INPUT

All data input for this application is done on one screen. The following list describes the necessary input parameters with their corresponding units and range of data recognized by this application:

<u>Item</u>	<u>Symbol</u>	<u>Units</u>	<u>Data Range</u>	
Significant wave height	H_s	ft, m	0.1	to 100.0
Significant wave period	T_s	sec	1.0	to 1000.0
Cotangent nearshore slope	$\cot \phi$		5.0	to 10000.0
Water depth at toe of revetment	d_s	ft, m	0.1	to 200.0
Cotangent of structure slope	$\cot \theta$		2.0	to 6.0
Unit weight of rock	w_r	lb/ft ³ , N/m ³	1.0	to 99999.0
Permeability coefficient	P		0.05	to 0.6
Damage level	S		2	to 17

OUTPUT

Results from this application are displayed on one screen. The results include the armor and filter layer thicknesses, stone size gradations (weight and size), and an expected extreme and conservative runoff on the riprap revetment.

<u>Item</u>	<u>Symbol</u>	<u>English Units</u>	<u>Metric Units</u>
Weight of individual armor and filter stone	W	lb	N
Armor/filter layer thickness	r	ft	m
Runup (expected maximum and conservative)	R	ft	m

PROCEDURE

The bulleted items in the following lists indicate potentially optional instruction steps. Any application in ACES may be executed in a given session without quitting the program. The bulleted items provide instructions for accessing the application from various menu areas of the ACES program. Ignore bulleted instruction steps that are not applicable.

Single Case Mode

- Press **F1** on the Main Menu to select Single Case Mode.
 - Fill in the highlighted input fields on the General Specifications screen (or leave the default values). Press **F1** when all data on this screen are correct.
 - Press **F4** on the Functional Area Menu to select Structural Design.
 - Press **F4** on the Structural Design Menu to select Rubble-Mound Revetment Design.
1. Fill in the highlighted input fields on the screen. Respond to any corrective instructions appearing at the bottom of the screens. Press **F1** when all data on this screen are correct.
 2. All output data are displayed on the screen in the final system of units.
 3. Press one of the following keys to select the appropriate action:
 - F1** Return to Step 1 for a new case.
 - F3** Send a summary of this case to the print file or device.
 - F10** Exit this application and return to the Structural Design Menu.

Multiple Case Mode

- Press **F2** on the Main Menu to select Multi Case Mode.
- Fill in the highlighted input fields on the General Specifications screen (or leave the default values). Press **F1** when all data on this screen are correct.
- Press **F4** on the Functional Area Menu to select Structural Design.
- Press **F4** on the Structural Design Menu to select Rubble-Mound Revetment Design.

1. Move the cursor to select a variable on the Rubble-Mound Revetment Design screen (the selected variable name blinks). The current set of values for the variable is displayed on the right portion of the screen. When all variable sets are correct, go to Step 3.
2. Enter a set of values for the subject variable by following one of the input methods:
 - a. Press **(R)** to select random method. Enter up to 20 values constituting a set for this variable (one in each field) on the right side of the screen. The set of 20 values originally displayed (first execution) in these fields contains the "delimiting" value, which "delimits" or "ends" the set. The "delimiting" value is *not* included as a member in the set unless it is the sole member.
 - b. Press **(I)** to select incremental method. Fill in the fields for minimum, maximum, and increment values for this variable on the right side of the screen. In this method, the members of the set include all values from the minimum to the maximum (both inclusive) at the specified increment.

The units field should also be specified for the variable regardless of input method. All members of a set of values for a subject variable are assigned the specified units. When all data are correct for the subject variable, press **(F10)** to return to Step 1. Errors are reported at the bottom of the screen and are corrected by pressing **(F1)** to allow respecification of the data for the subject variable.
3. Press **(F1)** to process the cases resulting from the combinations of the sets of data for all variables. The summary of each case will be sent to the print file or device. The screen will display the total number of cases to be processed as well as report progress. Errors are reported at the bottom of the screen and are corrected by pressing **(F1)** to allow respecification of variable sets.
4. Press one of the following keys to select the appropriate action:
 - (F1)** Return to Step 1 to specify new sets.
 - (F10)** Exit this application and return to the Structural Design Menu.

EXAMPLE PROBLEM

Input

All data input for this application is done on one screen. The values and corresponding units selected for this example problem are shown below.

<u>Item</u>	<u>Symbol</u>	<u>Value</u>	<u>Units</u>
Significant wave height	H_s	5.0	ft
Significant wave period	T_s	10.0	sec
Cotangent nearshore slope	$\cot \phi$	100.0	
Water depth at toe of revetment	d_s	9.0	ft
Cotangent of structure slope	$\cot \theta$	2.0	
Unit weight of rock	w_r	165.0	lb/ft ³
Permeability coefficient	P	0.1	
Damage level	S	2.0	

Output

Results from this application are displayed on one screen. The results include the armor and filter layer thicknesses, stone size gradations (weight and size), and an expected extreme and conservative runup on the riprap revetment.

ARMOR LAYER Thickness = 4.95 ft

PERCENT LESS THAN BY WEIGHT	WEIGHT (lbs)	DIMENSION (ft)
0.00	313.08	1.24
15.00	1001.84	1.82
50.00	2504.61	2.48
85.00	4909.04	3.10
100.00	10018.44	3.93

FILTER LAYER Thickness = 1.24 ft

PERCENT LESS THAN BY WEIGHT	WEIGHT (lbs)	DIMENSION (ft)
0.00	0.82	0.17
15.00	1.38	0.20
50.00	4.65	0.30
85.00	15.65	0.46
100.00	26.35	0.54

IRREGULAR WAVE RUNUP
 EXPECTED MAXIMUM = 10.96 ft
 CONSERVATIVE = 13.79 ft

REFERENCES AND BIBLIOGRAPHY

- Ahrens, J. P. 1975. "Large Wave Tank Tests of Riprap Stability," CERC Technical Memorandum 51, US Army Engineer Waterways Experiment Station, Vicksburg, MS.
- Ahrens, J. P. 1977. "Prediction of Irregular Wave Overtopping," CERC CETA 77-7, US Army Engineer Waterways Experiment Station, Vicksburg, MS.
- Ahrens, J. P. 1981. "Design of Riprap Revetments for Protection Against Wave Attack," CERC TP 81-5, US Army Engineer Waterways Experiment Station, Vicksburg, MS.
- Ahrens, J. P. 1987. "Characteristics of Reef Breakwaters," Technical Report CERC-87-17, US Army Engineer Waterways Experiment Station, Vicksburg, MS.
- Ahrens, J. P., and Heimbaugh, M. S. 1988. "Approximate Upperlimit of Irregular Wave Runup on Riprap," Technical Report CERC-88-5, US Army Engineer Waterways Experiment Station, Vicksburg, MS.
- Ahrens, J. P., and McCartney B. L. 1975. "Wave Period Effect on the Stability of Riprap," *Proceedings of Civil Engineering in the Oceans/III*, American Society of Civil Engineers, pp. 1019-1034.
- Battjes, J. A. 1974. "Surf Similarity," *Proceedings of the 14th Coastal Engineering Conference*, Copenhagen, Denmark.
- Bradbury, A. P., Allsop, N. W. H., and Latham, L-P. 1990. "Rock Armor Stability Formulae-Influence of Stone Shape and Layer Thickness," *Proceedings of the 22nd International Conference on Coastal Engineering*, Delft, The Netherlands.
- Broderick, L. L. 1983. "Riprap Stability, A Progress Report," *Proceedings of the Coastal Structures '83 Conference*, American Society of Civil Engineers, Arlington, VA, pp. 320-330.
- Broderick, L. L., and Ahrens, J. P. 1982. "Riprap Stability Scale Effects," CERC TP 82-3, US Army Engineer Waterways Experiment Station, Vicksburg, MS.
- Headquarters, Department of the Army. 1971. "Earth and Rock-Fill Dams, General Design and Constructions Operations," Engineer Manual 1110-2-2300, Washington, DC.
- Hudson, R. Y. 1958. "Design of Quarry Stone Cover Layers for Rubble Mound Breakwaters," Research Report 2-2, US Army Engineer Waterways Experiment Station, Vicksburg, MS.
- Shore Protection Manual*. 1984. 4th ed., 2 Vols., US Army Engineer Waterways Experiment Station, Coastal Engineering Research Center, US Government Printing Office, Washington, DC, Chapter 7.
- Van der Meer, J. W., and Pilarczyk, K. W. 1987. "Stability of Breakwater Armor Layers Deterministic and Probabilistic Design," Delft Hydraulics Communication No. 378, Delft, The Netherlands.
- Van der Meer, J. W. 1988a. "Deterministic and Probabilistic Design of Breakwater Armor Layers," *Journal of Waterways, Port, Coastal, and Ocean Engineering*, American Society of Civil Engineers, Vol. 114, No. 1, pp. 66-80.

Van der Meer, J. W. 1988b. "Rock Slopes and Gravel Beaches Under Wave Attack," Ph.d. Thesis, Department of Civil Engineering, Delft Technical University; also Delft Hydraulics Communication No. 396, Delft, The Netherlands.

IRREGULAR WAVE RUNUP ON BEACHES

TABLE OF CONTENTS

Description	5-1-1
Input	5-1-1
Output	5-1-1
Procedure	5-1-2
Single Case Mode	5-1-2
Multiple Case Mode	5-1-3
Example Problem	5-1-4
Input	5-1-4
Output	5-1-4
References and Bibliography	5-1-5

IRREGULAR WAVE RUNUP ON BEACHES

DESCRIPTION

This application provides an approach to calculate runup statistical parameters for wave runup on smooth slope linear beaches. To account for permeable and rough slope natural beaches, the present approach needs to be modified by multiplying the results for the smooth slope linear beaches by a reduction factor. However, there is no guidance for such a reduction due to the sparsity of good field data on wave runup. The approach used in this ACES application is based on existing laboratory data on irregular wave runup (Mase and Iwagaki, 1984; Mase, 1989).

INPUT

All data input for this application is done on one screen. The following list describes the necessary input parameters with their corresponding units and range of data recognized by this application:

<u>Item</u>	<u>Symbol</u>	<u>Units</u>	<u>Data Range</u>	
Deepwater significant wave height	H_{so}	ft, m	0.1	to 100.0
Peak energy wave period	T_p	sec	0.1	to 100.0
Cotangent of foreshore slope	$\cot\theta$		0.1	to 100.0

OUTPUT

Results from this application are displayed on one screen. Those data include the original input values (in final units) and the following parameter:

<u>Item</u>	<u>Symbol</u>	<u>English Units</u>	<u>Metric Units</u>
Runup			
Maximum runup	R_{max}	ft	m
Runup exceeded by 2 percent of the runups	R_2	ft	m

Average of the highest one-tenth of the runups	$R_{1/10}$	ft	m
Average of the highest one-third of the runups	$R_{1/3}$	ft	m
Average runup	\bar{R}	ft	m

PROCEDURE

The bulleted items in the following lists indicate potentially optional instruction steps. Any application in ACES may be executed in a given session without quitting the program. The bulleted items provide instructions for accessing the application from various menu areas of the ACES program. Ignore bulleted instruction steps that are not applicable.

Single Case Mode

- Press **F1** on the Main Menu to select Single Case Mode.
 - Fill in the highlighted input fields on the General Specifications screen (or leave the default values). Press **F1** when all data on this screen are correct.
 - Press **F5** on the Functional Area Menu to select Wave Runup, Transmission, and Overtopping.
 - Press **F1** on the Wave Runup, Transmission, and Overtopping Application Menu to select Irregular Wave Runup on Beaches.
1. Fill in the highlighted input fields on the Irregular Wave Runup on Beaches screen. Respond to any corrective instructions appearing at the bottom of the screen. Press **F1** when all data on this screen are correct.
 2. All input and output data are displayed on the screen in the final system of units.
 3. Press one of the following keys to select the appropriate action:
 - F1** Return to Step 1 for a new case.
 - F3** Send a summary of this case to the print file or device.
 - F10** Exit this application and return to the Wave Runup, Transmission, and Overtopping Menu.

Multiple Case Mode

- Press **(F2)** on the Main Menu to select Multi Case Mode.
 - Fill in the highlighted input fields on the General Specifications screen (or leave the default values). Press **(F1)** when all data on this screen are correct.
 - Press **(F5)** on the Functional Area Menu to select Wave Runup, Transmission, and Overtopping.
 - Press **(F1)** on the Wave Runup, Transmission, and Overtopping Application Menu to select Irregular Wave Runup on Beaches.
1. Move the cursor to select a variable on the Irregular Wave Runup on Beaches screen (the selected variable name blinks). The current set of values for the variable is displayed on the right portion of the screen. When all variable sets are correct, go to Step 3.
 2. Enter a set of values for the subject variable by following one of the input methods:
 - a. Press **(R)** to select random method. Enter up to 20 values constituting a set for this variable (one in each field) on the right side of the screen. The set of 20 values originally displayed (first execution) in these fields contains the "delimiting" value, which "delimits" or "ends" the set. The "delimiting" value is *not* included as a member in the set unless it is the sole member.
 - b. Press **(I)** to select incremental method. Fill in the fields for minimum, maximum, and increment values for this variable on the right side of the screen. In this method, the members of the set include all values from the minimum to the maximum (both inclusive) at the specified increment.

The units field should also be specified for the variable regardless of input method. All members of a set of values for a subject variable are assigned the specified units. When all data are correct for the subject variable, press **(F10)** to return to Step 1. Errors are reported at the bottom of the screen and are corrected by pressing **(F1)** to allow respecification of the data for the subject variable.

3. Press **(F1)** to process the cases resulting from the combinations of the sets of data for all variables. The summary of each case will be sent to the print file or device. The screen will display the total number of cases to be

processed as well as report progress. Errors are reported at the bottom of the screen and are corrected by pressing **F1** to allow respecification of variable sets.

4. Press one of the following keys to select the appropriate action:

F1 Return to Step 1 to specify new sets.

F10 Exit this application and return to the Wave Runup, Transmission, and Overtopping Menu.

EXAMPLE PROBLEM

Input

All data input for this application is done on one screen. The values and corresponding units selected for this first example problem are shown below.

<u>Item</u>	<u>Symbol</u>	<u>Value</u>	<u>Units</u>
Deepwater significant wave height	H_{80}	4.60	ft
Peak energy wave period	T_p	9.50	sec
Cotangent of foreshore slope	$\cot\theta$	13.00	

Output

Results from this application are displayed on one screen. Those data include the original input values and the following parameters:

<u>Item</u>	<u>Symbol</u>	<u>Value</u>	<u>Units</u>
Maximum runup	R_{\max}	8.74	ft
Runup exceeded by 2 percent of the runups	R_2	7.11	ft
Average of the highest one-tenth of the runups	$R_{1/10}$	6.50	ft
Average of the highest one-third of the runups	$R_{1/3}$	5.29	ft
Average runup	\bar{R}	3.38	ft

REFERENCES AND BIBLIOGRAPHY

- Hunt, I. A. 1959. "Design of Seawalls and Breakwaters," *Journal of the Waterway, Port, Coastal, and Ocean Engineering Division*, American Society Civil Engineers, Vol. 85, No. 3, pp. 123-152.
- Mase, H. 1989. "Random Wave Runup Height on Gentle Slopes," *Journal of the Waterway, Port, Coastal, and Ocean Engineering Division*, American Society Civil Engineers, Vol. 115, No. 5, pp. 649-661.
- Mase, H., and Iwagaki, Y. 1984. "Runup of Random Waves on Gentle Slopes," *Proceedings of the 19th International Conference on Coastal Engineering*, Houston, TX, American Society Civil Engineers, pp. 593-609.
- Walton, T. L., Jr., and Ahrens, J. P. 1989. "Maximum Periodic Wave Run-Up on Smooth Slopes," *Journal of the Waterway, Port, Coastal, and Ocean Engineering Division*, American Society Civil Engineers, Vol. 115, No. 5, pp. 703-708.
- Walton, T. L., Jr., Ahrens, J. P., Truitt, C. L., and Dean, R. G. 1989. "Criteria for Evaluating Coastal Flood-Protection Structures," Technical Report CERC-89-15, US Army Engineer Waterways Experiment Station, Vicksburg, MS.

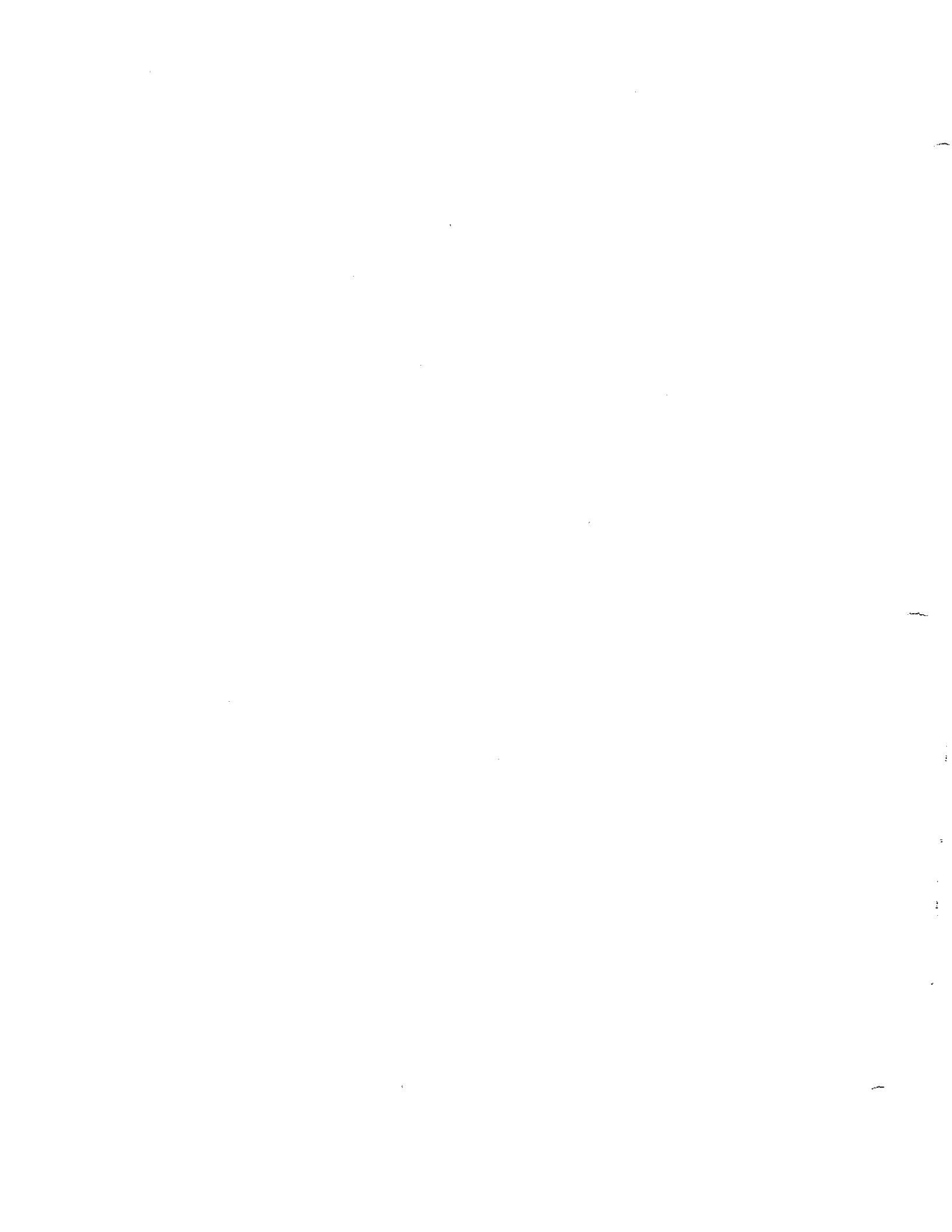

WAVE RUNUP AND OVERTOPPING ON IMPERMEABLE STRUCTURES

TABLE OF CONTENTS

Description	5-2-1
Input	5-2-1
Output	5-2-3
Procedure	5-2-3
Single Case Mode	5-2-3
Multiple Case Mode	5-2-5
Example Problems	5-2-7
Example 1 - Monochromatic Wave - Rough Slope Runup (Riprap)	5-2-7
Example 2 - Monochromatic Wave - Smooth Slope Runup	5-2-8
Example 3 - Monochromatic Wave - Rough Slope Overtopping	5-2-9
Example 4 - Monochromatic Wave - Smooth Slope Overtopping	5-2-10
Example 5 - Monochromatic Wave - Rough Slope Runup and Overtopping (Riprap)	5-2-11
Example 6 - Monochromatic Wave - Smooth Slope Runup and Overtopping	5-2-12
Example 7 - Irregular Wave - Rough Slope Runup and Overtopping (Riprap) ..	5-2-13
Example 8 - Irregular Wave - Smooth Slope Runup and Overtopping	5-2-14
References and Bibliography	5-2-15

WAVE RUNUP AND OVERTOPPING ON IMPERMEABLE STRUCTURES

DESCRIPTION

This application provides estimates of wave runup and overtopping on rough and smooth slope structures that are assumed to be impermeable. Run-up heights and overtopping rates are estimated independently or jointly for monochromatic or irregular waves specified at the toe of the structure. The empirical equations suggested by Ahrens and McCartney (1975), Ahrens and Titus (1985), and Ahrens and Burke (1987) are used to predict runup, and Weggel (1976) to predict overtopping. Irregular waves are represented by a significant wave height and are assumed to conform to a Rayleigh distribution (Ahrens, 1977). The overtopping rate is estimated by summing the overtopping contributions from individual runups in the distribution.

INPUT

The terminology used to define wave runup is shown in Figure 5-2-1.

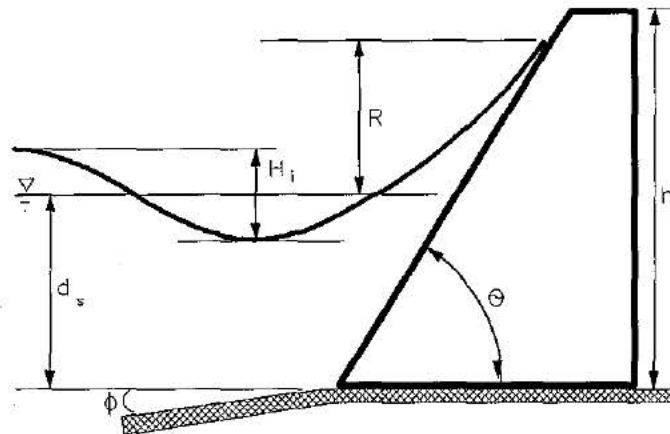

Figure 5-2-1. Wave Runup and Overtopping

All data input for this application is done on one screen. The following list describes the necessary input parameters with their corresponding units and range of data recognized by this application:

<u>Mandatory Item</u>	<u>Symbol</u>	<u>Units</u>	<u>Data Range</u>	
Incident wave height	H_i	ft, m	0.1	to 100.0
Wave period	T	sec	1.0	to 1000.0
Cotan of nearshore slope	$\cot \phi$		5.0	to 10000.0
Water depth at structure toe	d_s	ft, m	0.1	to 200.0
Cotan of structure slope	$\cot \Theta$		0.0	to 30.0

NOTE: For vertical walls, specify 0.0.

Structure height above toe	h_s	ft, m	0.0	to 200.0
----------------------------	-------	-------	-----	----------

The above input variables are mandatory. In addition, the following input variables are required under the specified circumstances:

<u>Item</u>	<u>Symbol</u>	<u>Source</u>
<u>Rough slope runup</u>		
Empirical coefficient	a	See Table A-3 of Appendix A for suggested values.
Empirical coefficient	b	

<u>Overtopping</u>		
Empirical coefficient	α	See Figures 7-24 to 7-34 in the SPM (1984).
Empirical coefficient	Q^*_0	

<u>Item</u>	<u>Symbol</u>	<u>Units</u>	<u>Data Range</u>	
Onshore wind velocity	U	kn, ft/sec mph, m/sec, kph	0.0	to 200.0
Wave runup (if known)	R	ft, m	0.0	to 100.0

NOTE: For irregular waves, substitute the following:

Incident significant wave height	(H_s)	for	H_i
Peak wave period	(T_p)	for	T

OUTPUT

Results from this application are displayed on one screen. Those data include the original input values (in final units) and the following parameters:

<u>Item</u>	<u>Symbol</u>		<u>English Units</u>	<u>Metric Units</u>
	monochromatic waves	irregular waves		
Deepwater				
Wave height	H_0	H_{s0}	ft	m
Relative height	d_s/H_0	d_s/H_{s0}		
Wave steepness	H_0/gT^2	H_{s0}/gT^2		
Runup	R (if requested)	R_s	ft	m
Overtopping rate	Q (if requested)	Q	ft ³ /sec-ft	m ³ /sec-m

The deepwater wave parameters are provided as an aid to determining the empirical overtopping coefficients from the referenced figures in the SPM (1984).

PROCEDURE

The bulleted items in the following lists indicate potentially optional instruction steps. Any application in ACES may be executed in a given session without quitting the program. The bulleted items provide instructions for accessing the application from various menu areas of the ACES program. Ignore bulleted instruction steps that are not applicable.

Single Case Mode

- Press **F1** on the Main Menu to select Single Case Mode.
- Fill in the highlighted input fields on the General Specifications screen (or leave the default values). Press **F1** when all data on this screen are correct.
- Press **F5** on the Functional Area Menu to select Wave Runup, Transmission, and Overtopping.
- Press **F2** on the Wave Runup, Transmission, and Overtopping Application Menu to select Wave Runup and Overtopping on Impermeable Structures.
- On the Wave Runup and Overtopping on Impermeable Structures Menu, press one of the following:

Selections for Monochromatic Waves

- F1** Estimate runup on rough slope structures.
- F2** Estimate runup on smooth slope structures.
- F3** or **F4** Estimate overtopping rate with a known run-up value.
- F5** Estimate both runup and overtopping rate on rough slope structures.
- F6** Estimate both runup and overtopping rate on smooth slope structures.

Selections for Irregular Waves

- F7** or **F8** Estimate overtopping rate with a known run-up value.

1. Fill in the highlighted input fields on the Wave Runup and Overtopping on Impermeable Structures screen. Respond to any corrective instructions appearing at the bottom of the screen. Press **F1** when all data on this screen are correct.

NOTE: If the selected case involved the computation of rough slope runup, **F10** may be pressed to provide access to the additional following options (choose one):

- F1** Return to the input screen.
- F2** Display a table of suggested rough slope run-up empirical coefficients (a and b). If this option is selected, these coefficients must be entered in the designated fields of the display screen. The data thus given will be transferred back to (and displayed on) the main input screen when **F1** is pressed.
- F10** Exit the application.

2. All input and output data are displayed on the screen in the final system of units.

3. Press one of the following keys to select the appropriate action:

- F1** Return to Step 1 for a new case.
- F3** Send a summary of this case to the print file or device.
- F10** Exit this application and return to the Wave Runup, Transmission, and Overtopping Menu.

Multiple Case Mode

Run-up values are provided in this operational mode, but overtopping rates are excluded because of possible functional dependencies between incident wave conditions, structure slope, and the empirical overtopping coefficients. Single Case or Batch Modes may be used to process cases providing overtopping rates.

- Press **F2** on the Main Menu to select Multi Case Mode.
 - Fill in the highlighted input fields on the General Specifications screen (or leave the default values). Press **F1** when all data on this screen are correct.
 - Press **F5** on the Functional Area Menu to select Wave Runup, Transmission, and Overtopping.
 - Press **F2** on the Wave Runup, Transmission, and Overtopping Application Menu to select Wave Runup and Overtopping on Impermeable Structures.
 - On the Wave Runup and Overtopping on Impermeable Structures Menu, press one of the following:
 - F1** Estimate runup on rough slope structures.

NOTE: Selection of this option will display the table of suggested rough slope run-up empirical coefficients (*a* and *b*). Fill in the highlighted input fields with the values for these items, and press **F1** to resume input on the main input screen, or press **F10** to exit the application.
 - F2** Estimate runup on smooth slope structures.
1. Move the cursor to select a variable on the Wave Runup and Overtopping on Impermeable Structures screen (the selected variable name blinks). The current set of values for the variable is displayed on the right portion of the screen. When all variable sets are correct, go to Step 3.
 2. Enter a set of values for the subject variable by following one of the input methods:
 - a. Press **R** to select random method. Enter up to 20 values constituting a set for this variable (one in each field) on the right side of the screen. The set of 20 values originally displayed (first execution) in these fields contains the "delimiting" value, which "delimits" or "ends" the set. The "delimiting" value is *not* included as a member in the set unless it is the sole member.

- b. Press **I** to select incremental method. Fill in the fields for minimum, maximum, and increment values for this variable on the right side of the screen. In this method, the members of the set include all values from the minimum to the maximum (both inclusive) at the specified increment.

The units field should also be specified for the variable regardless of input method. All members of a set of values for a subject variable are assigned the specified units. When all data are correct for the subject variable, press **F10** to return to Step 1. Errors are reported at the bottom of the screen and are corrected by pressing **F1** to allow respecification of the data for the subject variable.

3. Press **F1** to process the cases resulting from the combinations of the sets of data for all variables. The summary of each case will be sent to the print file or device. The screen will display the total number of cases to be processed as well as report progress. Errors are reported at the bottom of the screen and are corrected by pressing **F1** to allow respecification of variable sets.

4. Press one of the following keys to select the appropriate action:

F1 Return to Step 1 to specify new sets.

F10 Exit this application and return to the Wave Runup, Transmission, and Overtopping Menu.

EXAMPLE PROBLEMS**Example 1 - Monochromatic Wave - Rough Slope Runup (Riprap)****Input**

<u>Item</u>	<u>Symbol</u>	<u>Value</u>	<u>Units</u>
Incident wave height	H_i	7.50	ft
Wave period	T	10.00	sec
Cotan of nearshore slope	$\cot \phi$	100.00	
Water depth at structure toe	d_s	12.50	ft
Cotan of structure slope	$\cot \Theta$	3.00	
Structure height above toe	h_s	20.00	ft

Rough slope run-up item

Empirical coefficient	a	0.956	
Empirical coefficient	b	0.398	

Output

<u>Item</u>	<u>Symbol</u>	<u>Value</u>	<u>Units</u>
Deep water			
Wave height	H_0	6.386	ft
Relative height	d_s/H_0	1.957	
Wave steepness	H_0/gT^2	0.002	
Runup	R	9.421	ft

Example 2 - Monochromatic Wave - Smooth Slope Runup**Input**

<u>Item</u>	<u>Symbol</u>	<u>Value</u>	<u>Units</u>
Incident wave height	H_i	7.50	ft
Wave period	T	10.00	sec
Cotan of nearshore slope	$\cot \phi$	100.00	
Water depth at structure toe	d_s	12.50	ft
Cotan of structure slope	$\cot \Theta$	3.00	
Structure height above toe	h_s	20.00	ft

Output

<u>Item</u>	<u>Symbol</u>	<u>Value</u>	<u>Units</u>
Deep water			
Wave height	H_0	6.386	ft
Relative height	d_s/H_0	1.957	
Wave steepness	H_0/gT^2	0.002	
Runup	R	21.366	ft

Example 3 - Monochromatic Wave - Rough Slope Overtopping**Input**

<u>Item</u>	<u>Symbol</u>	<u>Value</u>	<u>Units</u>
Incident wave height	H_i	7.50	ft
Wave period	T	10.00	sec
Cotan of nearshore slope	$\cot \phi$	100.00	
Water depth at structure toe	d_s	12.50	ft
Cotan of structure slope	$\cot \Theta$	3.00	
Structure height above toe	h_s	20.00	ft

Overtopping item

Empirical coefficient (computed)	α	0.076463	
Empirical coefficient	Q^*_0	0.025	
Onshore wind velocity	U	35.000	kn
Wave runup (if known)	R	15.000	ft

Output

<u>Item</u>	<u>Symbol</u>	<u>Value</u>	<u>Units</u>
Deep water			
Wave height	H_0	6.386	ft
Relative height	d_s/H_0	1.957	
Wave steepness	H_0/gT^2	0.001985	
Overtopping rate	Q	3.565	ft ³ /sec-ft

Example 4 - Monochromatic Wave - Smooth Slope Overtopping**Input**

<u>Item</u>	<u>Symbol</u>	<u>Value</u>	<u>Units</u>
Incident wave height	H_i	7.50	ft
Wave period	T	10.00	sec
Cotan of nearshore slope	$\cot \phi$	100.00	
Water depth at structure toe	d_s	12.50	ft
Cotan of structure slope	$\cot \theta$	3.00	
Structure height above toe	h_s	20.00	ft

Overtopping item

Empirical coefficient (computed)	α	0.076463	
Empirical coefficient	Q^*_0	0.025	
Onshore wind velocity	U	35.000	kn
Wave runup (if known)	R	20.000	ft

Output

<u>Item</u>	<u>Symbol</u>	<u>Value</u>	<u>Units</u>
Deep water			
Wave height	H_0	6.386	ft
Relative height	d_s/H_0	1.957	
Wave steepness	H_0/gT^2	0.001985	
Overtopping rate	Q	5.368	ft ³ /sec-ft

Example 5 - Monochromatic Wave - Rough Slope Runup and Overtopping (Riprap)

Input

<u>Item</u>	<u>Symbol</u>	<u>Value</u>	<u>Units</u>
Incident wave height	H_i	7.50	ft
Wave period	T	10.00	sec
Cotan of nearshore slope	$\cot \phi$	100.00	
Water depth at structure toe	d_s	12.50	ft
Cotan of structure slope	$\cot \Theta$	3.00	
Structure height above toe	h_s	20.00	ft

Rough slope run-up item

Empirical coefficient	a	0.956	
Empirical coefficient	b	0.398	

Overtopping item

Empirical coefficient (computed)	α	0.076463	
Empirical coefficient	Q^*_0	0.025	
Onshore wind velocity	U	35.000	kn

Output

<u>Item</u>	<u>Symbol</u>	<u>Value</u>	<u>Units</u>
Deep water			
Wave height	H_0	6.386	ft
Relative height	d_s/H_0	1.957	
Wave steepness	H_0/gT^2	0.001985	
Runup	R	9.421	ft
Overtopping rate	Q	0.829	ft ³ /sec-ft

Example 6 - Monochromatic Wave - Smooth Slope Runup and Overtopping**Input**

<u>Item</u>	<u>Symbol</u>	<u>Value</u>	<u>Units</u>
Incident wave height	H_i	7.50	ft
Wave period	T	10.00	sec
Cotan of nearshore slope	$\cot \phi$	100.00	
Water depth at structure toe	d_s	12.50	ft
Cotan of structure slope	$\cot \theta$	3.00	
Structure height above toe	h_s	20.00	ft

Overtopping item

Empirical coefficient (computed)	α	0.076463	
Empirical coefficient	Q^*_0	0.025	
Onshore wind velocity	U	35.000	kn

Output

<u>Item</u>	<u>Symbol</u>	<u>Value</u>	<u>Units</u>
Deep water			
Wave height	H_0	6.386	ft
Relative height	d_s/H_0	1.957	
Wave steepness	H_0/gT^2	0.001985	
Runup	R	21.366	ft
Overtopping rate	Q	5.771	ft ³ /sec-ft

Example 7 - Irregular Wave - Rough Slope Runup and Overtopping (Riprap)**Input**

<u>Item</u>	<u>Symbol</u>	<u>Value</u>	<u>Units</u>
Incident wave height	H_s	7.50	ft
Wave period	T	10.00	sec
Cotan of nearshore slope	$\cot \phi$	100.00	
Water depth at structure toe	d_s	12.50	ft
Cotan of structure slope	$\cot \Theta$	3.00	
Structure height above toe	h_s	20.00	ft

Rough slope run-up item

Empirical coefficient	a	0.956	
Empirical coefficient	b	0.398	

Overtopping item

Empirical coefficient (computed)	α	0.076463	
Empirical coefficient	Q^*_0	0.025	
Onshore wind velocity	U	35.000	kn

Output

<u>Item</u>	<u>Symbol</u>	<u>Value</u>	<u>Units</u>
Deep water			
Wave height	H_{s0}	6.386	ft
Relative height	d_s/H_{s0}	1.957	
Wave steepness	H_{s0}/gT^2	0.001985	
Runup	R_s	9.421	ft
Overtopping rate	Q	0.287	ft ³ /sec-ft

Example 8 - Irregular Wave - Smooth Slope Runup and Overtopping**Input**

<u>Item</u>	<u>Symbol</u>	<u>Value</u>	<u>Units</u>
Incident wave height	H_s	7.50	ft
Wave period	T	10.00	sec
Cotan of nearshore slope	$\cot \phi$	100.00	
Water depth at structure toe	d_s	12.50	ft
Cotan of structure slope	$\cot \Theta$	3.00	
Structure height above toe	h_s	20.00	ft

Overtopping item

Empirical coefficient (computed)	α	0.076463	
Empirical coefficient	Q^*_0	0.025	
Onshore wind velocity	U	35.000	kn

Output

<u>Item</u>	<u>Symbol</u>	<u>Value</u>	<u>Units</u>
Deep water			
Wave height	H_{s0}	6.386	ft
Relative height	d_s/H_0	1.957	
Wave steepness	H_{s0}/gT^2	0.001985	
Runup	R_s	21.366	ft
Overtopping rate	Q	2.728	ft ³ /s-ft

REFERENCES AND BIBLIOGRAPHY

- Ahrens, J. P. 1977. "Prediction of Irregular Wave Overtopping," CERC CETA 77-7, US Army Engineer Waterways Experiment Station, Vicksburg, MS.
- Ahrens, J. P., and Burke, C. E. 1987. Unpublished report of modifications to method cited in above reference.
- Ahrens, J. P., and McCartney B. L. 1975. "Wave Period Effect on the Stability of Riprap," *Proceedings of Civil Engineering in the Oceans/III*, American Society of Civil Engineers, pp. 1019-1034.
- Ahrens, J. P., and Titus, M. F. 1985. "Wave Runup Formulas for Smooth Slopes," *Journal of Waterway, Port, Coastal and Ocean Engineering*, American Society of Civil Engineers, Vol. 111, No. 1, pp. 128-133.
- Battjes, J. A. 1974. "Surf Similarity," *Proceedings of the 14th Coastal Engineering Conference*, Copenhagen, Denmark.
- Dean, R. G. 1974. "Evaluation and Development of Water Wave Theories for Engineering Applications," Vols. 1-2, CERC Special Report No. 1, US Army Engineer Waterways Experiment Station, Vicksburg, MS.
- Douglass, S. L. 1986. "Review and Comparison of Methods for Estimating Irregular Wave Overtopping Rates," Technical Report CERC-86-12, US Army Engineer Waterways Experiment Station, Vicksburg, MS, pp. 6-14.
- Goda, Y. 1983. "A Unified Nonlinearity Parameter of Water Waves," *Report of the Port and Harbour Research Institute*, Vol. 22, No. 3, pp. 3-30.
- Saville, T., Jr. 1955. "Laboratory Data on Wave Run-Up and Overtopping on Shore Structures," TM No. 64, US Army Corps of Engineers, Beach Erosion Board, Washington, DC.
- Saville, T., Jr., and Caldwell, J. M. 1953. "Experimental Study of Wave Overtopping on Shore Structures," *Proceedings, Minnesota International Hydraulics Convention*, Minneapolis, MN.
- Seelig, W. N. 1980. "Two-Dimensional Tests of Wave Transmission and Reflection Characteristics of Laboratory Breakwaters," CERC TR 80-1, US Army Engineer Waterways Experiment Station, Vicksburg, MS.
- Shore Protection Manual*. 1984. 4th ed., 2 Vols., US Army Engineer Waterways Experiment Station, Coastal Engineering Research Center, US Government Printing Office, Washington, DC, Chapter 7, pp. 43-58.
- Smith, O. P. 1986. "Cost-Effective Optimization of Rubble-Mound Breakwater Cross Sections," Technical Report CERC-86-2, US Army Engineer Waterways Experiment Station, Vicksburg, MS, pp. 45-53.
- Weggel, J. R. 1972. "Maximum Breaker Height," *Journal of Waterways, Harbors and Coastal Engineering Division*, American Society of Civil Engineers, Vol. 98, No. WW4, pp. 529-548.
- Weggel, J. R. 1976. "Wave Overtopping Equation," *Proceedings of the 15th Coastal Engineering Conference*, American Society of Civil Engineers, Honolulu, HI, pp. 2737-2755.

WAVE TRANSMISSION ON IMPERMEABLE STRUCTURES

TABLE OF CONTENTS

Description	5-3-1
Input	5-3-1
Output	5-3-2
Procedure	5-3-3
Single Case Mode	5-3-3
Multiple Case Mode	5-3-4
Example Problems	5-3-6
Example 1 - Sloped Structure - Known Runup - Transmission Only	5-3-6
Example 2 - Vertical Wall with Berm (Submerged) - Transmission Only	5-3-6
Example 3 - Rough Slope - Runup and Transmission (Riprap)	5-3-7
Example 4 - Smooth Slope - Runup and Transmission	5-3-7
References and Bibliography	5-3-8

WAVE TRANSMISSION ON IMPERMEABLE STRUCTURES

DESCRIPTION

This application provides estimates of wave runup and transmission on rough and smooth slope structures. It also addresses wave transmission over impermeable vertical walls and composite structures. In all cases, monochromatic waves are specified at the toe of a structure that is assumed to be impermeable. For sloped structures, a method suggested by Ahrens and Titus (1985) and Ahrens and Burke (1987) is used to predict runup, while the method of Cross and Sollitt (1971) as modified by Seelig (1980) is used to predict overtopping. For vertical wall and composite structures, a method proposed by Goda, Takeda, and Moriya (1967) and Goda (1969) is used to predict wave transmission.

INPUT

The terminology used to define wave transmission on impermeable structures is shown in Figures 5-3-1 and 5-3-2.

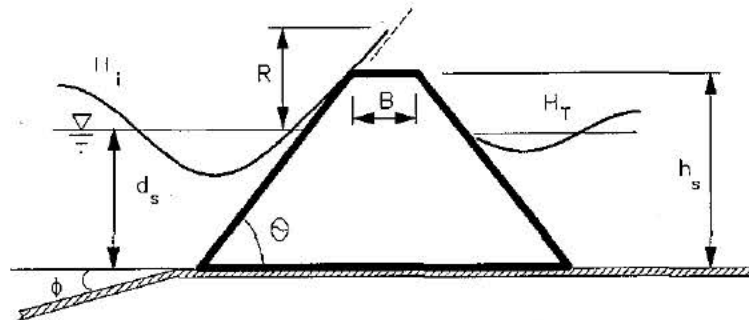

Figure 5-3-1. Wave Runup and Overtopping

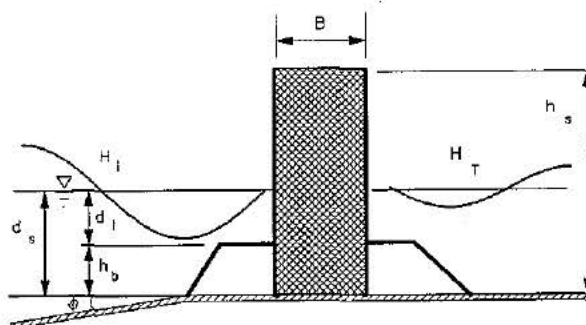

Figure 5-3-2. Composite Structure with Vertical Wall

All data input for this application is done on one screen. The following list describes the necessary input parameters with their corresponding units and range of data recognized by this application:

<u>Mandatory item</u>	<u>Symbol</u>	<u>Units</u>	<u>Data Range</u>	
Incident wave height	H_i	ft, m	0.1	to 100.0
Wave period	T	sec	1.0	to 1000.0
Cotan of nearshore slope	$\cot \phi$		5.0	to 10000.0
Water depth at structure toe	d_s	ft, m	0.1	to 200.0
Structure height above toe	h_s	ft, m	0.0	to 200.0
Structure crest width	B	ft, m	0.0	to 200.0

The above input variables are mandatory. In addition, the following input variables are required under the specified circumstances:

<u>Item</u>	<u>Symbol</u>	<u>Units</u>	<u>Data Range</u>	
<u>Rough and smooth slope</u>				
Cotan of structure slope	$\cot \theta$		0.0	to 30.0
Runup (if known)	R	ft, m	0.0	to 100.0

<u>Item</u>	<u>Symbol</u>	<u>Source</u>
<u>Rough slope runup</u>		
Empirical coefficient	a	See Table A-3 of Appendix A for suggested values.
Empirical coefficient	b	

<u>Item</u>	<u>Symbol</u>	<u>Units</u>	<u>Data Range</u>	
<u>Vertical wall</u>				
Toe protection or composite breakwater berm height above structure toe (if present)	h_b	ft, m	0.0	to 200.0

OUTPUT

Results from this application are displayed on one screen. Those data include the original input values (in final units) and the following parameters:

<u>Item</u>	<u>Symbol</u>	<u>English Units</u>	<u>Metric Units</u>
Wave runup (if requested)	R	ft	m
Transmitted wave height	H_T	ft	m

PROCEDURE

The bulleted items in the following lists indicate potentially optional instruction steps. Any application in ACES may be executed in a given session without quitting the program. The bulleted items provide instructions for accessing the application from various menu areas of the ACES program. Ignore bulleted instruction steps that are not applicable.

Single Case Mode

- Press **F1** on the Main Menu to select Single Case Mode.
- Fill in the highlighted input fields on the General Specifications screen (or leave the default values). Press **F1** when all data on this screen are correct.
- Press **F5** on the Functional Area Menu to select Wave Runup, Transmission, and Overtopping.
- Press **F3** on the Wave Runup, Transmission, and Overtopping Application Menu to select Wave Transmission on Impermeable Structures.
- On the Wave Transmission on Impermeable Structures Menu, press one of the following:
 - F1** Estimate wave transmission over a sloped structure (with a known run-up value).
 - F2** Estimate wave transmission over a vertical wall or composite breakwater.
 - F3** Estimate both runup and wave transmission on rough slope structures.
 - F4** Estimate both runup and wave transmission on smooth slope structures.
- 1. Fill in the highlighted input fields on the Wave Transmission on Impermeable Structures screen. Respond to any corrective instructions appearing at the bottom of the screen. Press **F1** when all data on this screen are correct.

NOTE: If the selected case involved the computation of rough slope runup, **F10** may be pressed to provide access to the additional following options (choose one):

- F1** Return to the input screen.

- (F2) Display a table of suggested rough slope run-up empirical coefficients (a and b). If this option is selected, these coefficients must be entered in the designated fields of the display screen. The data thus given will be transferred back to (and displayed on) the main input screen when (F1) is pressed.
 - (F10) Exit the application.
2. All input and output data are displayed on the screen in the final system of units.
 3. Press one of the following keys to select the appropriate action:
 - (F1) Return to Step 1 for a new case.
 - (F3) Send a summary of this case to the print file or device.
 - (F10) Exit this application and return to the Wave Runup, Transmission, and Overtopping Menu.

Multiple Case Mode

Run-up values and the associated transmitted wave heights over sloped structures are provided in this operational mode. Also, wave transmission over vertical walls and composite structures is handled. Wave transmission with known run-up values on sloped structures is excluded because of possible functional dependencies between given incident wave conditions, structure slope, and run-up values. Single Case or Batch Modes may be used to process cases providing wave transmission with known run-up values.

- Press (F2) on the Main Menu to select Multi Case Mode.
- Fill in the highlighted input fields on the General Specifications screen (or leave the default values). Press (F1) when all data on this screen are correct.
- Press (F5) on the Functional Area Menu to select Wave Runup, Transmission, and Overtopping.
- Press (F3) on the Wave Runup, Transmission, and Overtopping Application Menu to select Wave Transmission on Impermeable Structures.
- On the Wave Transmission on Impermeable Structures Menu, press one of the following:
 - (F2) Estimate wave transmission over vertical walls or composite structures.
 - (F3) Estimate runup and wave transmission on rough slope structures.

NOTE: Selection of this option will display the table of suggested rough slope run-up empirical coefficients (a and b). Fill in the highlighted input fields with the values for these items, and press **F1** to resume input on the main input screen, or press **F10** to exit the application.

F4 Estimate runup and wave transmission on smooth slope structures.

1. Move the cursor to select a variable on the Wave Transmission on Impermeable Structures screen (the selected variable name blinks). The current set of values for the variable is displayed on the right portion of the screen. When all variable sets are correct, go to Step 3.
2. Enter a set of values for the subject variable by following one of the input methods:
 - a. Press **R** to select random method. Enter up to 20 values constituting a set for this variable (one in each field) on the right side of the screen. The set of 20 values originally displayed (first execution) in these fields contains the "delimiting" value, which "delimits" or "ends" the set. The "delimiting" value is *not* included as a member in the set unless it is the sole member.
 - b. Press **I** to select incremental method. Fill in the fields for minimum, maximum, and increment values for this variable on the right side of the screen. In this method, the members of the set include all values from the minimum to the maximum (both inclusive) at the specified increment.

The units field should also be specified for the variable regardless of input method. All members of a set of values for a subject variable are assigned the specified units. When all data are correct for the subject variable, press **F10** to return to Step 1. Errors are reported at the bottom of the screen and are corrected by pressing **F1** to allow respecification of the data for the subject variable.

3. Press **F1** to process the cases resulting from the combinations of the sets of data for all variables. The summary of each case will be sent to the print file or device. The screen will display the total number of cases to be processed as well as report progress. Errors are reported at the bottom of the screen and are corrected by pressing **F1** to allow respecification of variable sets.
4. Press one of the following keys to select the appropriate action:
 - F1** Return to Step 1 to specify new sets.
 - F10** Exit this application and return to the Wave Runup, Transmission, and Overtopping Menu.

EXAMPLE PROBLEMS**Example 1 - Sloped Structure - Known Runup - Transmission Only****Input**

<u>Item</u>	<u>Symbol</u>	<u>Value</u>	<u>Units</u>
Incident wave height	H_i	7.50	ft
Wave period	T	10.00	sec
Cotan of nearshore slope	$\cot \phi$	100.00	
Water depth at structure toe	d_s	10.00	ft
Cotan of structure slope	$\cot \Theta$	3.00	
Structure height above toe	h_s	15.00	ft
Structure crest width	B	7.50	ft
Known runup	R	15.00	ft

Output

<u>Item</u>	<u>Symbol</u>	<u>Value</u>	<u>Units</u>
Transmitted wave height	H_T	2.275	ft

Example 2 - Vertical Wall with Berm (Submerged) - Transmission Only**Input**

<u>Item</u>	<u>Symbol</u>	<u>Value</u>	<u>Units</u>
Incident wave height	H_i	7.50	ft
Wave period	T	4.50	sec
Cotan of nearshore slope	$\cot \phi$	100.00	
Water depth at structure toe	d_s	20.00	ft
Structure height above toe	h_s	17.50	ft
Structure crest width	B	12.00	ft
Structure berm height above toe	h_b	6.00	ft

Output

<u>Item</u>	<u>Symbol</u>	<u>Value</u>	<u>Units</u>
Transmitted wave height	H_T	3.798	ft

Example 3 - Rough Slope - Runup and Transmission (Riprap)**Input**

<u>Item</u>	<u>Symbol</u>	<u>Value</u>	<u>Units</u>
Incident wave height	H_i	7.50	ft
Wave period	T	10.00	sec
Cotan of nearshore slope	$\cot \phi$	100.00	
Water depth at structure toe	d_s	10.00	ft
Cotan of structure slope	$\cot \Theta$	3.00	
Structure height above toe	h_s	15.00	ft
Structure crest width	B	7.50	ft
Empirical coefficient	a	0.956	
Empirical coefficient	b	0.398	

Output

<u>Item</u>	<u>Symbol</u>	<u>Value</u>	<u>Units</u>
Wave runup	R	9.421	ft
Transmitted wave height	H_T	1.601	ft

Example 4 - Smooth Slope - Runup and Transmission**Input**

<u>Item</u>	<u>Symbol</u>	<u>Value</u>	<u>Units</u>
Incident wave height	H_i	7.50	ft
Wave period	T	10.00	sec
Cotan of nearshore slope	$\cot \phi$	100.00	
Water depth at structure toe	d_s	10.00	ft
Cotan of structure slope	$\cot \Theta$	3.00	
Structure height above toe	h_s	15.00	ft
Structure crest width	B	7.50	ft

Output

<u>Item</u>	<u>Symbol</u>	<u>Value</u>	<u>Units</u>
Wave runup	R	22.436	ft
Transmitted wave height	H_T	2.652	ft

REFERENCES AND BIBLIOGRAPHY

- Ahrens, J. P. 1977. "Prediction of Irregular Wave Overtopping," CERC CETA 77-7, US Army Engineer Waterways Experiment Station, Vicksburg, MS.
- Ahrens, J. P., and Burke, C. E. 1987. Unpublished report of modifications to method cited in above reference.
- Ahrens, J. P., and Titus, M. F. 1985. "Wave Runup Formulas for Smooth Slopes," *Journal of Waterway, Port, Coastal and Ocean Engineering*, American Society of Civil Engineers, Vol. 111, No. 1, pp. 128-133.
- Battjes, J. A. 1974. "Surf Similarity," *Proceedings of the 14th Coastal Engineering Conference*, Copenhagen, Denmark.
- Cross, R., and Sollitt, C. 1971. "Wave Transmission by Overtopping," Technical Note No. 15, Massachusetts Institute of Technology, Ralph M. Parsons Laboratory, Boston.
- Douglass, S. L. 1986. "Review and Comparison of Methods for Estimating Irregular Wave Overtopping Rates," Technical Report CERC-86-12, US Army Engineer Waterways Experiment Station, Vicksburg, MS, pp. 6-14.
- Goda, Y. 1969. "Reanalysis of Laboratory Data on Wave Transmission over Breakwaters," *Report of the Port and Harbour Research Institute*, Vol. 8, No. 3.
- Goda, Y. 1983. "A Unified Nonlinearity Parameter of Water Waves," *Report of the Port and Harbour Research Institute*, Vol. 22, No. 3, pp. 3-30.
- Goda, Y., Takeda, H., and Moriya, Y. 1967. "Laboratory Investigation of Wave Transmission over Breakwaters," *Report of the Port and Harbour Research Institute*, No. 13.
- Saville, T., Jr. 1955. "Laboratory Data on Wave Run-Up and Overtopping on Shore Structures," TM No. 64, US Army Corps of Engineers, Beach Erosion Board, Washington, DC.
- Seelig, W. N. 1976. "A Simplified Method for Determining Vertical Breakwater Crest Elevation Considering Wave Height Transmitted by Overtopping," CERC CDM 76-1, US Army Engineer Waterways Experiment Station, Vicksburg, MS.
- Seelig, W. N. 1980. "Two-Dimensional Tests of Wave Transmission and Reflection Characteristics of Laboratory Breakwaters," CERC TR 80-1, US Army Engineer Waterways Experiment Station, Vicksburg, MS.
- Shore Protection Manual*. 1984. 4th ed., 2 Vols., US Army Engineer Waterways Experiment Station, Coastal Engineering Research Center, US Government Printing Office, Washington, DC, Chapter 7, pp. 61-80.
- Smith, O. P. 1986. "Cost-Effective Optimization of Rubble-Mound Breakwater Cross Sections," Technical Report CERC-86-2, US Army Engineer Waterways Experiment Station, Vicksburg, MS, pp. 45-53.
- Weggel, J. R. 1972. "Maximum Breaker Height," *Journal of Waterways, Harbors and Coastal Engineering Division*, American Society of Civil Engineers, Vol. 98, No. WW4, pp. 529-548.

WAVE TRANSMISSION THROUGH PERMEABLE STRUCTURES

TABLE OF CONTENTS

Description	5-4-1
Input	5-4-1
First Screen	5-4-1
Second Screen (Breakwater Geometry Input)	5-4-2
Output	5-4-3
Procedure	5-4-3
Single Case Mode	5-4-3
Multiple Case Mode	5-4-4
Example Problems	5-4-6
Example 1 - Breakwater (3 Materials and 3 Layers)	5-4-6
Input	5-4-6
First Screen	5-4-6
Second Screen (Breakwater Geometry Input)	5-4-6
Output	5-4-7
Example 2 - Breakwater (3 Materials and 4 Layers)	5-4-8
Input	5-4-8
First Screen	5-4-8
Second Screen (Breakwater Geometry Input)	5-4-8
Output	5-4-9
References and Bibliography	5-4-10

WAVE TRANSMISSION THROUGH PERMEABLE STRUCTURES

DESCRIPTION

Porous rubble-mound structures consisting of quarry stones of various sizes often offer an attractive solution to the problem of protecting a harbor against wave action. It is important to assess the effectiveness of a given breakwater design by predicting the amount of wave energy transmitted by the structure. This application determines wave transmission coefficients and transmitted wave heights for permeable breakwaters with crest elevations at or above the still-water level. This application can be used with breakwaters armored with stone or artificial armor units. The application uses a method developed for predicting wave transmission by overtopping coefficients using the ratio of breakwater freeboard to wave runup (suggested by Cross and Sollitt, 1971). The wave transmission by overtopping prediction method is then combined with the model of wave reflection and wave transmission through permeable structures of Madsen and White (1976). Seelig (1979,1980) had developed a similar version for mainframe processors.

INPUT

All data input for this application is done on two screens. For each screen the necessary input parameters with their corresponding units and range of data recognized by this application are given below.

First Screen

<u>Item</u>	<u>Symbol</u>	<u>Units</u>	<u>Data Range</u>	
Incident wave height	H_i	ft, m	0.1	to 100.0
Wave period	T	sec	1.0	to 1000.0
Water depth at structure	d_s	ft, m	0.1	to 200.0
Number of materials comprising the breakwater	NM		1	to 4

Mean diameter of each material d_{50} ft, m 0.05 to 99.0

NOTE: Determine the mean diameter of a given material using the following relation:

$$d_{50} = \left(\frac{W_{50}}{\gamma} \right)^{\frac{1}{3}} \quad \text{where: } W_{50} = \text{median weight}$$

$$\gamma = \text{specific weight}$$

Porosity of each material P % See Table A-2, Appendix A

Second Screen (Breakwater Geometry Input)

<u>Item</u>	<u>Symbol</u>	<u>Units</u>	<u>Data Range</u>	
Units		ft, m		
Structure height above toe	h_s	ft, m	0.1	to 200.0
Cotangent of structure slope	$\cot \theta$		1.0	to 5.0
Structure crest width	B	ft, m	0.1	to 200.0
Number of horizontal layers in the breakwater	NL		1	to 4

NOTE: Divide the breakwater into horizontal layers. A new layer occurs any time there is a change vertically in any material type. Make the layer next to the seabed *layer number 1* and proceed upward.

Thickness of each horizontal layer	TH	ft, m	0.1	to 200.0
Horizontal length of each material in each layer	LL	ft, m	0.0	to 200.0

NOTE: Determine an *average* horizontal length of each material in each layer. This average length is measured at the *midpoint* of each layer. Remove the outer layer of armor from the seaward face of the breakwater before making length calculations, because the energy dissipation on the front face is determined separately.

OUTPUT

Results from this application are displayed on one screen. Those data include the original input values (in final units) and the following parameters:

<u>Item</u>	<u>Symbol</u>	<u>English Units</u>	<u>Metric Units</u>
Wave reflection coefficient	K_R		
Wave transmission coefficients			
Through	K_{Tt}		
Overtopping	K_{To}		
Total	K_T		
Transmitted wave height	H_T	ft	m

PROCEDURE

The bulleted items in the following lists indicate potentially optional instruction steps. Any application in ACES may be executed in a given session without quitting the program. The bulleted items provide instructions for accessing the application from various menu areas of the ACES program. Ignore bulleted instruction steps that are not applicable.

Single Case Mode

- Press **F1** on the Main Menu to select Single Case Mode.
- Fill in the highlighted input fields on the General Specifications screen (or leave the default values). Press **F1** when all data on this screen are correct.
- Press **F5** on the Functional Area Menu to select Wave Runup, Transmission, and Overtopping.
- Press **F4** on the Wave Runup, Transmission, and Overtopping Menu to select Wave Transmission Through Permeable Structures.

1. Fill in the highlighted input fields on the first screen; then press **F1** to obtain the second screen in this application, and fill in the input fields. Respond to any corrective instructions appearing at the bottom of the screens. Press **F1** when all data on this second screen are correct.
2. All output data and selected input data are displayed on the screen in the final system of units.
3. Press one of the following keys to select the appropriate action:
 - F1** Return to Step 1 for a new case.
 - F3** Send a summary of this case to the print file or device.
 - F10** Exit this application and return to the Wave Runup, Transmission, and Overtopping Menu.

Multiple Case Mode

- Press **F2** on the Main Menu to select Multi Case Mode.
 - Fill in the highlighted input fields on the General Specifications screen (or leave the default values). Press **F1** when all data on this screen are correct.
 - Press **F5** on the Functional Area Menu to select Wave Runup, Transmission, and Overtopping.
 - Press **F4** on the Wave Runup, Transmission, and Overtopping Menu to select Wave Transmission Through Permeable Structures.
1. Fill in the highlighted input fields on the first screen; then press **F1** to obtain the second screen in this application, and fill in the input fields. Respond to any corrective instructions appearing at the bottom of the screen. Press **F1** when all data on this second screen are correct to obtain the third data input screen.
 2. Move the cursor to select the wave height or wave period variable on this screen (the selected variable name blinks). The current set of values for the variable is displayed on the right portion of the screen. When all variable sets are correct, go to Step 4.

3. Enter a set of values for the subject variable by following one of the input methods:
 - a. Press **(R)** to select random method. Enter up to 20 values constituting a set for this variable (one in each field) on the right side of the screen. The set of 20 values originally displayed (first execution) in these fields contains the "delimiting" value, which "delimits" or "ends" the set. The "delimiting" value is *not* included as a member in the set unless it is the sole member.
 - b. Press **(I)** to select incremental method. Fill in the fields for minimum, maximum, and increment values for this variable on the right side of the screen. In this method, the members of the set include all values from the minimum to the maximum (both inclusive) at the specified increment.

The units field should also be specified for the variable regardless of input method. All members of a set of values for a subject variable are assigned the specified units. When all data are correct for the subject variable, press **(F10)** to return to Step 1. Errors are reported at the bottom of the screen and are corrected by pressing **(F1)** to allow respecification of the data for the subject variable.

4. Press **(F1)** to process the cases resulting from the combinations of the sets of data for all variables. The summary of each case will be sent to the print file or device. The screen will display the total number of cases to be processed as well as report progress. Errors are reported at the bottom of the screen and are corrected by pressing **(F1)** to allow respecification of variable sets.
5. Press one of the following keys to select the appropriate action:
 - (F1)** Return to Step 1 to specify new sets.
 - (F10)** Exit this application and return to the Wave Runup, Transmission, and Overtopping Menu.

EXAMPLE PROBLEMS

Example 1 - Breakwater (3 Materials and 3 Layers)

Input

All data input for this application is done on two screens. For each screen the values and corresponding units selected for this first example problem are shown below.

First Screen

<u>Item</u>	<u>Symbol</u>	<u>Value</u>	<u>Units</u>
Wave Characteristics			
Incident wave height	H_i	6.56	ft
Wave period	T	20.00	sec
Water depth at structure	d_s	15.75	ft

<u>Item</u>	<u>Symbol</u>	<u>Value</u>
Material Characteristics		
Number of materials comprising the breakwater	NM	3
Units		ft
Mean diameter of material 1-Armor	d_{50}	2.39
Mean diameter of material 2-Underlayer		1.11
Mean diameter of material 3-Core		0.30
Porosity of material 1	P	37%
Porosity of material 2		37%
Porosity of material 3		37%

Second Screen (Breakwater Geometry Input)

See Figure 5-4-1 for the breakwater dimensions used in this first example.

<u>Item</u>	<u>Symbol</u>	<u>Value</u>
Units		ft
Structure height above toe	h_s	19.69
Cotangent of structure slope	$\cot \theta$	1.5
Structure crest width	B	8.27
Number of horizontal layers in the breakwater	NL	3

Thickness of layer 1	TH_1	11.65
Thickness of layer 2	TH_2	2.56
Thickness of layer 3	TH_3	1.54

Note: Sum of the layer thicknesses must = the water depth.

Length of material 1 in layer 1	$LL_{1,1}$	14.76 _(9.84+4.92)
Length of material 1 in layer 2	$LL_{1,2}$	14.76 _(9.84+4.92)
Length of material 1 in layer 3	$LL_{1,3}$	17.39
Length of material 2 in layer 1	$LL_{2,1}$	12.46 _(6.23+6.23)
Length of material 2 in layer 2	$LL_{2,2}$	8.20
Length of material 2 in layer 3	$LL_{2,3}$	0.0
Length of material 3 in layer 1	$LL_{3,1}$	21.00
Length of material 3 in layer 2	$LL_{3,2}$	0.0
Length of material 3 in layer 3	$LL_{3,3}$	0.0

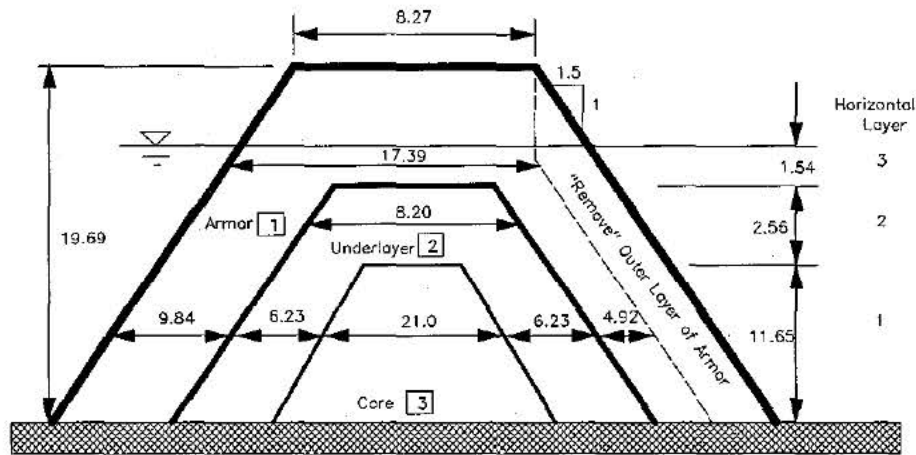

Figure 5-4-1. Sample Problem 1 - Breakwater Geometry

Output

<u>Item</u>	<u>Symbol</u>	<u>Value</u>	<u>Units</u>
Wave reflection coefficient	K_R	0.719	
Wave transmission coefficients			
Through	K_{Tt}	0.077	
Overtopping	K_{To}	0.227	
Total	K_T	0.239	
Transmitted wave height	H_T	1.570	ft

Example 2 - Breakwater (3 Materials and 4 Layers)

Input

All data input for this application is done on two screens. For each screen the values and corresponding units selected for this second example problem are shown below.

First Screen

<u>Item</u>	<u>Symbol</u>	<u>Value</u>	<u>Units</u>
Wave Characteristics			
Incident wave height	H_1	10	ft
Wave period	T	15.00	sec
Water depth at structure	d_s	25.00	ft

<u>Item</u>	<u>Symbol</u>	<u>Value</u>
Material Characteristics		
Number of materials comprising the breakwater	NM	3
Units		ft
Mean diameter of material 1	d_{50}	3.61
Armor-16,000 lb units (170 lb/ft ³)		
Mean diameter of material 2		2.07
Underlayer-3,000 lb stone (170 lb/ft ³)		
Mean diameter of material 3		1.05
Core-400 lb stone (170 lb/ft ³)		
Porosity of material 1	P	37%
Porosity of material 2		37%
Porosity of material 3		37%

Second Screen (Breakwater Geometry Input)

See Figure 5-4-2 for the breakwater dimensions used in this second example.

<u>Item</u>	<u>Symbol</u>	<u>Value</u>
Units		ft
Structure height above toe	h_s	38.00
Cotangent of structure slope	$\cot\theta$	1.75
Structure crest width	B	18.00
Number of horizontal layers in the breakwater	NL	4

Thickness of layer 1	TH_1	4.00
Thickness of layer 2	TH_2	8.00
Thickness of layer 3	TH_3	7.00
Thickness of layer 4	TH_4	6.00

Note: Sum of the layer thicknesses must = the water depth.

Length of material 1 in layer 1	$LL_{1,1}$	0
Length of material 1 in layer 2	$LL_{1,2}$	0
Length of material 1 in layer 3	$LL_{1,3}$	10
Length of material 1 in layer 4	$LL_{1,4}$	28 ₍₁₀₊₁₈₎
Length of material 2 in layer 1	$LL_{2,1}$	14
Length of material 2 in layer 2	$LL_{2,2}$	36
Length of material 2 in layer 3	$LL_{2,3}$	46 ₍₁₆₊₃₀₎
Length of material 2 in layer 4	$LL_{2,4}$	32
Length of material 3 in layer 1	$LL_{3,1}$	128
Length of material 3 in layer 2	$LL_{3,2}$	75
Length of material 3 in layer 3	$LL_{3,3}$	22
Length of material 3 in layer 4	$LL_{3,4}$	0

NOTE: Length of a particular material is measured at the *midpoint* of the layer.

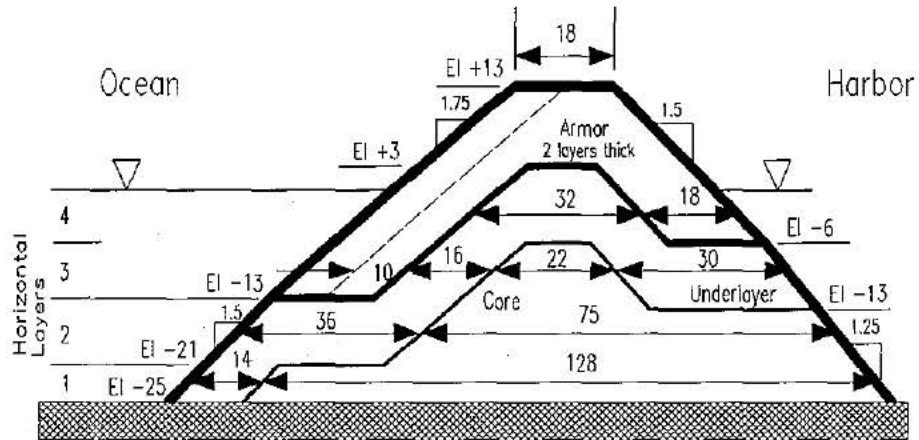

Figure 5-4-2. Sample Problem 2 - Breakwater Geometry

Output

<u>Item</u>	<u>Symbol</u>	<u>Value</u>	<u>Units</u>
Wave reflection coefficient	K_R	0.662	
Wave transmission coefficients			
Through	K_{Tt}	0.055	
Overtopping	K_{To}	0	
Total	K_T	0.055	
Transmitted wave height	H_T	0.550	ft

REFERENCES AND BIBLIOGRAPHY

- Ahrens, J. P., and McCartney B. L. 1975. "Wave Period Effect on the Stability of Riprap," *Proceedings of Civil Engineering in the Oceans/III*, American Society of Civil Engineers, pp. 1019-1034.
- Bear, J., et al. 1968. *Physical Principles of Water Percolation and Seepage*, United Nations Educational, Scientific and Cultural Organization.
- Cross, R., and Sollitt, C. 1971. "Wave Transmission by Overtopping," Technical Note No. 15, Ralph M. Parsons Laboratory, Massachusetts Institute of Technology, Boston.
- Madsen, O. S., and White, S. M. 1976. "Reflection and Transmission Characteristics of Porous Rubble-Mound Breakwaters," CERC MR 76-5, US Army Engineer Waterways Experiment Station, Vicksburg, MS.
- Morris, A. H. 1981. "NSWC/DL Library of Mathematics Subroutines," NSWC-TR-81-410, Naval Surface Weapons Center, Dahlgren, VA.
- Seelig, W. N. 1979. "Estimation of Wave Transmission Coefficients for Permeable Breakwaters," CERC CETA 79-6, US Army Engineer Waterways Experiment Station, Vicksburg, MS.
- Seelig, W. N. 1980. "Two-Dimensional Tests of Wave Transmission and Reflection Characteristics of Laboratory Breakwaters," CERC TR 80-1, US Army Engineer Waterways Experiment Station, Vicksburg, MS.

LONGSHORE SEDIMENT TRANSPORT

TABLE OF CONTENTS

Description	6-1-1
Input	6-1-1
Coastal Engineering Data Retrieval System	6-1-2
CEDRS Percent Occurrence Table Files	6-1-2
Sediment Transport Direction Convention	6-1-4
Output	6-1-5
Procedure	6-1-6
Single Case Mode	6-1-6
Multiple Case Mode	6-1-7
Example Problems	6-1-9
Example 1 - Deepwater Wave Condition	6-1-9
Input	6-1-9
Output	6-1-9
Example 2 - Breaking Wave Condition	6-1-9
Input	6-1-9
Output	6-1-9
Example 3 - Transport Using CEDRS Percent Occurrence Data	6-1-10
Input	6-1-10
Output	6-1-10
References and Bibliography	6-1-20

LONGSHORE SEDIMENT TRANSPORT

DESCRIPTION

This application provides estimates of the *potential* longshore transport rate under the action of waves. The method used is based on the empirical relationship between the longshore component of wave energy flux entering the surf zone and the immersed weight of sand moved (Galvin, 1979). Three methods are available to the user depending on whether available input data are breaker wave height and direction, deepwater wave height and direction, or using a Wave Information Study hindcast data file created by the Coastal Engineering Data Retrieval System (CEDRS). The material presented herein can be found in Chapter 4 of the *Shore Protection Manual* (1984) and in Gravens (1988).

INPUT

All data input for this application is done on one screen. The following list describes the necessary input parameters with their corresponding units and range of data recognized by this application:

<u>Mandatory item</u>	<u>Symbol</u>	<u>Units</u>	<u>Data Range</u>		
Breaking wave height	H_b	ft, m	0.1	to	100.0
Deepwater wave height	H_o	ft, m	0.1	to	100.0
Wave crest angle with shoreline	α_b	deg	0.0	to	90.0
Deepwater angle of wave crest	α_o	deg	0.0	to	90.0
Empirical coefficient	K		0.0	to	1.0

These items are required when using a CEDRS data file. *For information on CEDRS and input requirements see section entitled "Coastal Engineering Data Retrieval System."*

Shore-normal azimuth	Θ	deg	0.0	to	360.0
Empirical coefficient	K		0.0	to	1.0
External CEDRS file name			??xxx.810		

This ACES application will read the various regional data files containing the percent occurrence statistical data in the form of tables that reside on the CEDRS auxiliary hard disk. These data files have the following DOS name convention:

??xxx.810

where

?? = coast (see Table 6-1-2)

xxx = station on the coast

Table 6-1-2 Coast Designation	
??	Region
a2	Atlantic
g1	Gulf
p2	Pacific
e0	Lake Erie
h0	Lake Huron
m0	Lake Michigan
s0	Lake Superior
o0	Lake Ontario

To use a particular regional data file in this ACES application, type in the regional data file name and directory path name to the CEDRS directory where the regional file exists.

Sediment Transport Direction Convention

For calculation of potential longshore sand transport using the CEDRS percent occurrence data files, a right-handed coordinate system is used, in which waves approaching normal to the shoreline are given an angle of 0 deg. Looking seaward, waves approaching from the right are associated with negative angles, and waves approaching from the left are associated with positive angles such that positive transport is directed to the right. The shore-normal azimuth θ is measured clockwise from true north (see Figure 6-1-2).

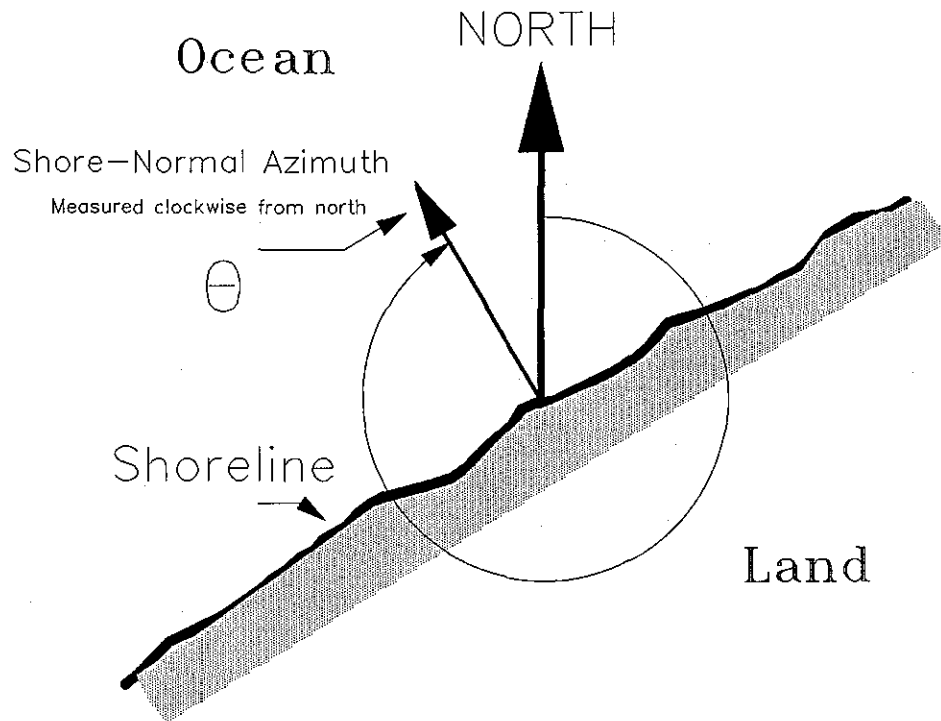

Figure 6-1-2. Definition Diagram for Shore-Normal Azimuth

OUTPUT

Results from this application are displayed on one screen. Those data include the original input values (in final units) and the following:

<u>Item</u>	<u>Symbol</u>	<u>English Units</u>	<u>Metric Units</u>
Transport rate	Q	yd ³ /yr	m ³ /yr

When the CEDRS data file is used, the following additional data are output: The wave bands that approach the specified shoreline; the wave direction angle associated with the wave band; and the percentage of the transport rate for each contributing wave band (see Example 3).

PROCEDURE

The bulleted items in the following lists indicate potentially optional instruction steps. Any application in ACES may be executed in a given session without quitting the program. The bulleted items provide instructions for accessing the application from various menu areas of the ACES Program. Ignore bulleted instruction steps that are not applicable.

Single Case Mode

- Press **F1** on the Main Menu to select Single Case Mode.
 - Fill in the highlighted input fields on the General Specifications screen (or leave the default values). Press **F1** when all data on this screen are correct.
 - Press **F6** on the Functional Area Menu to select Littoral Processes.
 - Press **F1** on the Littoral Processes Application Menu to select Longshore Sediment Transport.
 - On the Longshore Sediment Transport Menu, press one of the following:
 - F1** Estimate the transport rate using deepwater wave conditions.
 - F2** Estimate the transport rate using breaking wave conditions.
 - F3** Estimate the transport rate using CEDRS statistical data: Percent Occurrence of Wave Height & Period by Direction. *For information on CEDRS and input requirements see section entitled "Coastal Engineering Data Retrieval System."*
 - F10** Exit application
1. Fill in the highlighted input fields on the Longshore Sediment Transport screen. Respond to any corrective instructions appearing at the bottom of the screen. Press **F1** when all data on this screen are correct.
 2. All input and output data are displayed on the screen in the final system of units.
 3. Press one of the following keys to select the appropriate action:
 - F1** Return to Step 1 for a new case.
 - F3** Send a summary of this case to the print file or device.

- **F10** Exit this application and return to the Littoral Processes Menu.

Multiple Case Mode

- Press **F2** on the Main Menu to select Multi Case Mode.
 - Fill in the highlighted input fields on the General Specifications screen (or leave the default values). Press **F1** when all data on this screen are correct.
 - Press **F6** on the Functional Area Menu to select Littoral Processes.
 - Press **F1** on the Littoral Processes Application Menu to select Longshore Sediment Transport.
 - On the Longshore Sediment Transport Menu, press one of the following:
 - F1** Estimate the transport rate using deepwater wave conditions.
 - F2** Estimate the transport rate using breaking wave conditions.
1. Move the cursor to select a variable on the Longshore Sediment Transport screen (the selected variable name blinks). The current set of values for the variable is displayed on the right portion of the screen. When all variable sets are correct, go to Step 3.
 2. Enter a set of values for the subject variable by following one of the input methods:
 - a. Press **R** to select random method. Enter up to 20 values constituting a set for this variable (one in each field) on the right side of the screen. The set of 20 values originally displayed (first execution) in these fields contains the "delimiting" value, which "delimits" or "ends" the set. The "delimiting" value is *not* included as a member in the set unless it is the sole member.
 - b. Press **I** to select incremental method. Fill in the fields for minimum, maximum, and increment values for this variable on the right side of the screen. In this method, the members of the set include all values from the minimum to the maximum (both inclusive) at the specified increment.

The units field should also be specified for the variable regardless of input method. All members of a set of values for a subject variable are assigned the specified units. When all data are correct for the subject variable, press **F10** to return to Step 1. Errors are reported at the bottom of the screen and are corrected by pressing **F1** to allow respecification of the data for the subject variable.

3. Press **F1** to process the cases resulting from the combinations of the sets of data for all variables. The summary of each case will be sent to the print file or device. The screen will display the total number of cases to be processed as well as report progress. Errors are reported at the bottom of the screen and are corrected by pressing **F1** to allow respecification of variable sets.
4. Press one of the following keys to select the appropriate action:
 - F1** Return to Step 1 to specify new sets.
 - F10** Exit this application and return to the Littoral Processes Menu.

EXAMPLE PROBLEMS**Example 1 - Deepwater Wave Condition****Input**

All data input for this application is done on one screen. The values and corresponding units selected for this first example problem are shown below.

<u>Item</u>	<u>Symbol</u>	<u>Value</u>	<u>Units</u>
Deepwater wave height	H_o	1.75	ft
Deepwater angle of wave crest	α_o	15.00	deg
Empirical coefficient	K	0.39	

Output

Results from this application are displayed on one screen. Those data include the original input values and the following parameter:

<u>Item</u>	<u>Symbol</u>	<u>Value</u>	<u>Units</u>
Transport rate	Q	275,234	yd ³ /yr

Example 2 - Breaking Wave Condition**Input**

All data input for this application is done on one screen. The values and corresponding units selected for this second example problem are shown below.

<u>Item</u>	<u>Symbol</u>	<u>Value</u>	<u>Units</u>
Breaking wave height	H_b	3.75	ft
Wave crest angle with shoreline	α_b	12.00	deg
Empirical coefficient	K	0.39	

Output

Results from this application are displayed on one screen. Those data include the original input values and the following parameter:

<u>Item</u>	<u>Symbol</u>	<u>Value</u>	<u>Units</u>
Transport rate	Q	2,662,872	yd ³ /yr

Example 3 - Transport Using CEDRS Percent Occurrence Data

Input

All data input for this application is done on one screen. The values and corresponding units selected for this second example problem are shown below.

<u>Item</u>	<u>Symbol</u>	<u>Value</u>	<u>Units</u>
Shore-Normal Azimuth (see Figure 6-1-3)	θ	40.0	deg
Empirical coefficient	K	0.39	
External CEDRS File (see Table 6-1-3) (WIS Report 18, pp. C73-C77)		G1033.810	

Output

Results from this application are displayed on one screen. Those data include the original input values and the following:

Band	Angle From Shore-Normal	Contributing Percentage	Transport Rate (cu yd/yr)
15	85.00	72.22	9822.69
16	62.50	100.00	67924.60
1	40.00	100.00	89224.06
2	17.50	100.00	60693.54
3	-5.00	100.00	-30549.34
4	-27.50	100.00	-279184.05
5	-50.00	100.00	-556982.29
6	-72.5	100.00	-215797.42
7	-95.00	27.78	-0.56
		Total	-854848.77

NOTE: Looking seaward, negative transport is directed to the left.

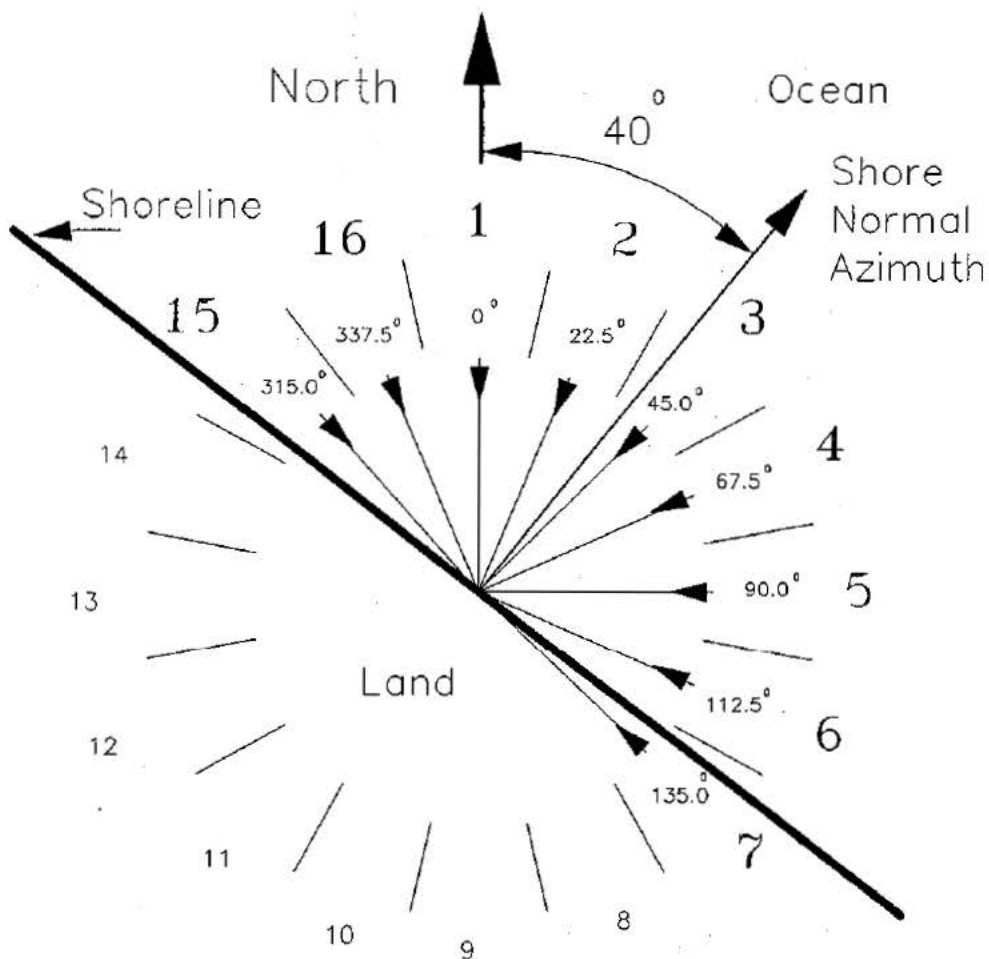

Figure 6-1-3. Shore-Normal Azimuth Definition for Example 6-1-3

Table 6-1-3
 CEDRS Statistical File for Gulf of Mexico Station No. 33
 (File G1033.810)
 (WIS Report 18, pp. C73-C77)

PERCENT OCCURRENCE (X1000) OF HEIGHT AND PERIOD BY DIRECTION
 22.5 DEGREES ABOUT 0.0 DEGREES AZIMUTH

STATION: G1033 (29.0N, 85.5W / 68.0M)		NO. CASES: 1335									
		% OF TOTAL: 2.3									
HEIGHT IN METERS	PEAK PERIOD (IN SECONDS)										TOTAL
	<4.2	4.2- 5.3	5.4- 6.5	6.6- 7.4	7.5- 8.7	8.8- 9.5	9.6- 10.5	10.6- 11.8	11.9- 13.3	13.4- LONGER	
0.00-0.49	34	30	5	69
0.50-0.99	378	532	30	940
1.00-1.49	.	780	99	879
1.50-1.99	.	.	345	3	348
2.00-2.49	.	.	42	42
2.50-2.99	.	.	1	1
3.00-3.49	0
3.50-3.99	0
4.00-4.49	0
4.50-4.99	0
5.00+	0
TOTAL	412	1342	522	3	0	0	0	0	0	0	
MEAN HS(M) = 1.1		LARGEST HS(M) = 2.5				MEAN TP(SEC) = 4.8					

PERCENT OCCURRENCE (X1000) OF HEIGHT AND PERIOD BY DIRECTION
 22.5 DEGREES ABOUT 22.5 DEGREES AZIMUTH

STATION: G1033 (29.0N, 85.5W / 68.0M)		NO. CASES: 1471									
		% OF TOTAL: 2.5									
HEIGHT IN METERS	PEAK PERIOD (IN SECONDS)										TOTAL
	<4.2	4.2- 5.3	5.4- 6.5	6.6- 7.4	7.5- 8.7	8.8- 9.5	9.6- 10.5	10.6- 11.8	11.9- 13.3	13.4- LONGER	
0.00-0.49	66	41	15	122
0.50-0.99	321	602	56	979
1.00-1.49	1	888	104	993
1.50-1.99	.	.	359	1	360
2.00-2.49	.	.	58	58
2.50-2.99	0
3.00-3.49	0
3.50-3.99	0
4.00-4.49	0
4.50-4.99	0
5.00+	0
TOTAL	388	1531	592	1	0	0	0	0	0	0	
MEAN HS(M) = 1.1		LARGEST HS(M) = 2.4				MEAN TP(SEC) = 4.8					

(Table 6-1-3 Continued on the Next Page)

(Table 6-1-3 Continued)

PERCENT OCCURRENCE (X1000) OF HEIGHT AND PERIOD BY DIRECTION
22.5 DEGREES ABOUT 45.0 DEGREES AZIMUTH

STATION: G1033 (29.0N, 85.5W / 68.0M)

NO. CASES: 2256

% OF TOTAL: 3.9

HEIGHT IN METERS	PEAK PERIOD (IN SECONDS)										TOTAL
	<4.2	4.2- 5.3	5.4- 6.5	6.6- 7.4	7.5- 8.7	8.8- 9.5	9.6- 10.5	10.6- 11.8	11.9- 13.3	13.4- LONGER	
0.00-0.49	75	18	23	116
0.50-0.99	629	915	39	1583
1.00-1.49	1	1302	135	1438
1.50-1.99	.	.	592	592
2.00-2.49	.	.	126	126
2.50-2.99	0
3.00-3.49	0
3.50-3.99	0
4.00-4.49	0
4.50-4.99	0
5.00+	0
TOTAL	705	2235	915	0	0	0	0	0	0	0	0

MEAN HS(M) = 1.1 LARGEST HS(M) = 2.4 MEAN TP(SEC) = 4.7

PERCENT OCCURRENCE (X1000) OF HEIGHT AND PERIOD BY DIRECTION
22.5 DEGREES ABOUT 67.5 DEGREES AZIMUTH

STATION: G1033 (29.0N, 85.5W / 68.0M)

NO. CASES: 4915

% OF TOTAL: 8.4

HEIGHT IN METERS	PEAK PERIOD (IN SECONDS)										TOTAL
	<4.2	4.2- 5.3	5.4- 6.5	6.6- 7.4	7.5- 8.7	8.8- 9.5	9.6- 10.5	10.6- 11.8	11.9- 13.3	13.4- LONGER	
0.00-0.49	213	53	135	401
0.50-0.99	675	2250	181	3106
1.00-1.49	.	3151	532	3	3686
1.50-1.99	.	3	1052	6	1061
2.00-2.49	.	.	147	3	150
2.50-2.99	0
3.00-3.49	0
3.50-3.99	0
4.00-4.49	0
4.50-4.99	0
5.00+	0
TOTAL	888	5457	2047	12	0	0	0	0	0	0	0

MEAN HS(M) = 1.1 LARGEST HS(M) = 2.4 MEAN TP(SEC) = 4.8

(Table 6-1-3 Continued on the Next Page)

(Table 6-1-3 Continued)

PERCENT OCCURRENCE (X1000) OF HEIGHT AND PERIOD BY DIRECTION
22.5 DEGREES ABOUT 90.0 DEGREES AZIMUTH

STATION: G1033 (29.0N, 85.5W / 68.0M) NO. CASES: 9243
% OF TOTAL: 15.8

HEIGHT IN METERS	PEAK PERIOD (IN SECONDS)										TOTAL LONGER
	<4.2	4.2- 5.3	5.4- 6.5	6.6- 7.4	7.5- 8.7	8.8- 9.5	9.6- 10.5	10.6- 11.8	11.9- 13.3	13.4-	
0.00-0.49	472	296	75	843
0.50-0.99	980	4433	374	5787
1.00-1.49	.	2320	4712	159	7191
1.50-1.99	.	18	874	831	44	1767
2.00-2.49	.	.	71	39	100	210
2.50-2.99	.	.	5	.	5	10
3.00-3.49	0
3.50-3.99	0
4.00-4.49	0
4.50-4.99	0
5.00+	0
TOTAL	1452	7067	6111	1029	149	0	0	0	0	0	0
MEAN HS(M) = 1.0	LARGEST HS(M) = 2.8				MEAN TP(SEC) = 5.2						

PERCENT OCCURRENCE (X1000) OF HEIGHT AND PERIOD BY DIRECTION
22.5 DEGREES ABOUT 112.5 DEGREES AZIMUTH

STATION: G1033 (29.0N, 85.5W / 68.0M) NO. CASES: 8139
% OF TOTAL: 13.9

HEIGHT IN METERS	PEAK PERIOD (IN SECONDS)										TOTAL LONGER
	<4.2	4.2- 5.3	5.4- 6.5	6.6- 7.4	7.5- 8.7	8.8- 9.5	9.6- 10.5	10.6- 11.8	11.9- 13.3	13.4-	
0.00-0.49	412	345	112	869
0.50-0.99	925	4404	545	5874
1.00-1.49	.	716	4609	547	5872
1.50-1.99	.	.	246	828	58	1132
2.00-2.49	.	.	6	23	102	1	132
2.50-2.99	.	.	.	3	27	30
3.00-3.49	1	5	6
3.50-3.99	0
4.00-4.49	0
4.50-4.99	0
5.00+	0
TOTAL	1337	5465	5518	1401	188	6	0	0	0	0	0
MEAN HS(M) = 1.0	LARGEST HS(M) = 3.2				MEAN TP(SEC) = 5.3						

(Table 6-1-3 Continued on the Next Page)

(Table 6-1-3 Continued)

PERCENT OCCURRENCE (X1000) OF HEIGHT AND PERIOD BY DIRECTION
22.5 DEGREES ABOUT 135.0 DEGREES AZIMUTH

STATION: G1033 (29.0N, 85.5W / 68.0M)

NO. CASES: 6876
% OF TOTAL: 11.8

HEIGHT IN METERS	PEAK PERIOD (IN SECONDS)										TOTAL
	<4.2	4.2- 5.3	5.4- 6.5	6.6- 7.4	7.5- 8.7	8.8- 9.5	9.6- 10.5	10.6- 11.8	11.9- 13.3	13.4- LONGER	
0.00-0.49	496	381	39	916
0.50-0.99	853	3417	662	1	4933
1.00-1.49	1	638	3307	513	3	4462
1.50-1.99	.	.	119	961	136	1216
2.00-2.49	.	.	.	23	160	3	186
2.50-2.99	15	15	30
3.00-3.49	11	11
3.50-3.99	0
4.00-4.49	0
4.50-4.99	0
5.00+	0
TOTAL	1350	4436	4127	1498	314	29	0	0	0	0	
MEAN HS(M) = 1.0		LARGEST HS(M) = 3.4				MEAN TP(SEC) = 5.3					

PERCENT OCCURRENCE (X1000) OF HEIGHT AND PERIOD BY DIRECTION
22.5 DEGREES ABOUT 157.5 DEGREES AZIMUTH

STATION: G1033 (29.0N, 85.5W / 68.0M)

NO. CASES: 4619
% OF TOTAL: 7.9

HEIGHT IN METERS	PEAK PERIOD (IN SECONDS)										TOTAL
	<4.2	4.2- 5.3	5.4- 6.5	6.6- 7.4	7.5- 8.7	8.8- 9.5	9.6- 10.5	10.6- 11.8	11.9- 13.3	13.4- LONGER	
0.00-0.49	133	128	77	338
0.50-0.99	627	1875	477	6	2985
1.00-1.49	1	487	2345	319	1	3153
1.50-1.99	.	.	119	766	203	1088
2.00-2.49	.	.	.	25	249	6	280
2.50-2.99	39	5	44
3.00-3.49	3	3
3.50-3.99	0
4.00-4.49	0
4.50-4.99	0
5.00+	0
TOTAL	761	2490	3018	1116	495	11	0	0	0	0	
MEAN HS(M) = 1.1		LARGEST HS(M) = 3.0				MEAN TP(SEC) = 5.5					

(Table 6-1-3 Continued on the Next Page)

(Table 6-1-3 Continued)

PERCENT OCCURRENCE (X1000) OF HEIGHT AND PERIOD BY DIRECTION
22.5 DEGREES ABOUT 180.0 DEGREES AZIMUTH

STATION: G1033 (29.0N, 85.5W / 68.0M) NO. CASES: 3024
% OF TOTAL: 5.2

HEIGHT IN METERS	PEAK PERIOD (IN SECONDS)										TOTAL
	<4.2	4.2- 5.3	5.4- 6.5	6.6- 7.4	7.5- 8.7	8.8- 9.5	9.6- 10.5	10.6- 11.8	11.9- 13.3	13.4- LONGER	
0.00-0.49	131	71	90	292
0.50-0.99	453	1483	277	2213
1.00-1.49	.	369	1185	191	8	1753
1.50-1.99	.	.	100	503	97	700
2.00-2.49	.	.	1	34	159	1	195
2.50-2.99	6	5	11
3.00-3.49	0
3.50-3.99	0
4.00-4.49	0
4.50-4.99	0
5.00+	0
TOTAL	584	1923	1653	728	270	6	0	0	0	0	

MEAN HS(M) = 1.0 LARGEST HS(M) = 2.9 MEAN TP(SEC) = 5.4

PERCENT OCCURRENCE (X1000) OF HEIGHT AND PERIOD BY DIRECTION
22.5 DEGREES ABOUT 202.5 DEGREES AZIMUTH

STATION: G1033 (29.0N, 85.5W / 68.0M) NO. CASES: 2470
% OF TOTAL: 4.2

HEIGHT IN METERS	PEAK PERIOD (IN SECONDS)										TOTAL
	<4.2	4.2- 5.3	5.4- 6.5	6.6- 7.4	7.5- 8.7	8.8- 9.5	9.6- 10.5	10.6- 11.8	11.9- 13.3	13.4- LONGER	
0.00-0.49	75	66	66	207
0.50-0.99	458	1401	241	11	2111
1.00-1.49	.	241	922	160	17	1340
1.50-1.99	.	.	87	302	53	6	1	.	.	.	449
2.00-2.49	.	.	1	15	71	87
2.50-2.99	15	3	18
3.00-3.49	3	3
3.50-3.99	0
4.00-4.49	0
4.50-4.99	0
5.00+	0
TOTAL	533	1708	1317	488	156	12	1	0	0	0	

MEAN HS(M) = 1.0 LARGEST HS(M) = 3.0 MEAN TP(SEC) = 5.3

(Table 6-1-3 Continued on the Next Page)

(Table 6-1-3 Continued)

PERCENT OCCURRENCE (X1000) OF HEIGHT AND PERIOD BY DIRECTION
22.5 DEGREES ABOUT 225.0 DEGREES AZIMUTH

STATION: G1033 (29.0N, 85.5W / 68.0M)

NO. CASES: 3459
% OF TOTAL: 5.9

HEIGHT IN METERS	PEAK PERIOD (IN SECONDS)										TOTAL
	<4.2	4.2- 5.3	5.4- 6.5	6.6- 7.4	7.5- 8.7	8.8- 9.5	9.6- 10.5	10.6- 11.8	11.9- 13.3	13.4- LONGER	
0.00-0.49	78	210	124	412
0.50-0.99	557	1810	272	25	1	2665
1.00-1.49	.	361	1630	188	22	6	2207
1.50-1.99	.	.	83	311	59	5	458
2.00-2.49	.	.	.	20	85	3	108
2.50-2.99	.	.	.	1	35	6	42
3.00-3.49	13	13
3.50-3.99	0
4.00-4.49	0
4.50-4.99	0
5.00+	0
TOTAL	635	2381	2109	545	202	33	0	0	0	0	

MEAN HS(M) = 1.0 LARGEST HS(M) = 3.3 MEAN TP(SEC) = 5.3

PERCENT OCCURRENCE (X1000) OF HEIGHT AND PERIOD BY DIRECTION
22.5 DEGREES ABOUT 247.5 DEGREES AZIMUTH

STATION: G1033 (29.0N, 85.5W / 68.0M)

NO. CASES: 2885
% OF TOTAL: 4.9

HEIGHT IN METERS	PEAK PERIOD (IN SECONDS)										TOTAL
	<4.2	4.2- 5.3	5.4- 6.5	6.6- 7.4	7.5- 8.7	8.8- 9.5	9.6- 10.5	10.6- 11.8	11.9- 13.3	13.4- LONGER	
0.00-0.49	131	191	73	395
0.50-0.99	557	1813	260	6	2636
1.00-1.49	1	278	968	181	6	1434
1.50-1.99	.	.	80	244	37	361
2.00-2.49	.	.	.	23	63	86
2.50-2.99	6	.	1	.	.	.	7
3.00-3.49	1	3	.	.	.	4
3.50-3.99	0
4.00-4.49	0
4.50-4.99	0
5.00+	0
TOTAL	689	2282	1381	454	112	1	4	0	0	0	

MEAN HS(M) = 0.9 LARGEST HS(M) = 3.3 MEAN TP(SEC) = 5.1

(Table 6-1-3 Continued on the Next Page)

(Table 6-1-3 Continued)

PERCENT OCCURRENCE (X1000) OF HEIGHT AND PERIOD BY DIRECTION
22.5 DEGREES ABOUT 270.0 DEGREES AZIMUTH

STATION: G1033 (29.0N, 85.5W / 68.0M) NO. CASES: 2210
% OF TOTAL: 3.8

HEIGHT IN METERS	PEAK PERIOD (IN SECONDS)										TOTAL LONGER
	<4.2	4.2- 5.3	5.4- 6.5	6.6- 7.4	7.5- 8.7	8.8- 9.5	9.6- 10.5	10.6- 11.8	11.9- 13.3	13.4-	
0.00-0.49	121	97	46	264
0.50-0.99	391	1031	361	10	1793
1.00-1.49	1	140	740	189	10	1080
1.50-1.99	.	.	106	290	68	464
2.00-2.49	.	.	8	46	90	144
2.50-2.99	25	1	26
3.00-3.49	0
3.50-3.99	0
4.00-4.49	0
4.50-4.99	0
5.00+	0
TOTAL	513	1268	1261	535	193	1	0	0	0	0	

MEAN HS(M) = 1.0 LARGEST HS(M) = 2.8 MEAN TP(SEC) = 5.3

PERCENT OCCURRENCE (X1000) OF HEIGHT AND PERIOD BY DIRECTION
22.5 DEGREES ABOUT 292.5 DEGREES AZIMUTH

STATION: G1033 (29.0N, 85.5W / 68.0M) NO. CASES: 2189
% OF TOTAL: 3.7

HEIGHT IN METERS	PEAK PERIOD (IN SECONDS)										TOTAL LONGER
	<4.2	4.2- 5.3	5.4- 6.5	6.6- 7.4	7.5- 8.7	8.8- 9.5	9.6- 10.5	10.6- 11.8	11.9- 13.3	13.4-	
0.00-0.49	44	56	58	158
0.50-0.99	301	939	330	1	1571
1.00-1.49	.	210	869	116	1	1196
1.50-1.99	.	1	179	453	6	639
2.00-2.49	.	.	8	119	42	169
2.50-2.99	3	3
3.00-3.49	0
3.50-3.99	0
4.00-4.49	0
4.50-4.99	0
5.00+	0
TOTAL	345	1206	1444	689	52	0	0	0	0	0	

MEAN HS(M) = 1.1 LARGEST HS(M) = 2.7 MEAN TP(SEC) = 5.5

(Table 6-1-3 Continued on the Next Page)

(Table 6-1-3 Continued)

PERCENT OCCURRENCE (X1000) OF HEIGHT AND PERIOD BY DIRECTION
22.5 DEGREES ABOUT 315.0 DEGREES AZIMUTH

STATION: G1033 (29.0N, 85.5W / 68.0M) NO. CASES: 1884
% OF TOTAL: 3.2

HEIGHT IN METERS	PEAK PERIOD (IN SECONDS)										TOTAL LONGER
	<4.2	4.2- 5.3	5.4- 6.5	6.6- 7.4	7.5- 8.7	8.8- 9.5	9.6- 10.5	10.6- 11.8	11.9- 13.3	13.4-	
0.00-0.49	49	71	35	155
0.50-0.99	256	872	106	1234
1.00-1.49	.	669	588	27	1284
1.50-1.99	.	1	285	200	1	487
2.00-2.49	.	.	10	37	1	48
2.50-2.99	.	.	1	5	6
3.00-3.49	0
3.50-3.99	0
4.00-4.49	0
4.50-4.99	0
5.00+	0
TOTAL	305	1613	1025	269	2	0	0	0	0	0	0

MEAN HS(M) = 1.1 LARGEST HS(M) = 2.9 MEAN TP(SEC) = 5.1

PERCENT OCCURRENCE (X1000) OF HEIGHT AND PERIOD BY DIRECTION
22.5 DEGREES ABOUT 337.5 DEGREES AZIMUTH

STATION: G1033 (29.0N, 85.5W / 68.0M) NO. CASES: 1465
% OF TOTAL: 2.5

HEIGHT IN METERS	PEAK PERIOD (IN SECONDS)										TOTAL LONGER
	<4.2	4.2- 5.3	5.4- 6.5	6.6- 7.4	7.5- 8.7	8.8- 9.5	9.6- 10.5	10.6- 11.8	11.9- 13.3	13.4-	
0.00-0.49	63	41	10	114
0.50-0.99	369	619	100	1088
1.00-1.49	1	795	123	919
1.50-1.99	.	5	306	3	314
2.00-2.49	.	.	58	3	61
2.50-2.99	.	.	3	1	4
3.00-3.49	0
3.50-3.99	0
4.00-4.49	0
4.50-4.99	0
5.00+	0
TOTAL	433	1460	600	7	0	0	0	0	0	0	0

MEAN HS(M) = 1.0 LARGEST HS(M) = 2.7 MEAN TP(SEC) = 4.7

(Table 6-1-3 Continued on the Next Page)

(Table 6-1-3 Concluded)

PERCENT OCCURRENCE (X1000) OF HEIGHT AND PERIOD
FOR ALL DIRECTIONS

STATION: G1033 (29.0N, 85.5W / 68.0M) NO. CASES: 58440

HEIGHT IN METERS	PEAK PERIOD (IN SECONDS)										TOTAL
	<4.2	4.2-	5.4-	6.6-	7.5-	8.8-	9.6-	10.6-	11.9-	13.4-	
		5.3	6.5	7.4	8.7	9.5	10.5	11.8	13.3	LONGER	
0.00-0.49	2600	2103	990	5693
0.50-0.99	8740	8403	4317	65	1	1526
1.00-1.49	11	3352	2876	2599	71	6	8915
1.50-1.99	.	30	4940	5710	768	11	1	.	.	.	1460
2.00-2.49	.	.	542	417	1129	17	2105
2.50-2.99	.	.	11	11	181	37	1	.	.	.	241
3.00-3.49	5	35	3	.	.	.	43
3.50-3.99	0
4.00-4.49	0
4.50-4.99	0
5.00+	0
TOTAL	11351	43888	33676	8802	2155	106	5	0	0	0	

MEAN HS(M) = 1.0 LARGEST HS(M) = 3.4 MEAN TP(SEC) = 5.2

REFERENCES AND BIBLIOGRAPHY

Coastal Engineering Technical Note II-19 1989. "Estimating Potential Longshore Sand Transport Rates Using WIS Data," US Army Engineer Waterways Experiment Station, Vicksburg, MS.

Galvin, C. J. 1979. "Relation Between Immersed Weight and Volume Rates of Longshore Transport," CERC TP 79-1, US Army Engineer Waterways Experiment Station, Vicksburg, MS.

Galvin, C. J., and Schweppe, C. R. 1980. "The SPM Energy Flux Method for Predicting Longshore Transport Rate," CERC TP 80-4, US Army Engineer Waterways Experiment Station, Vicksburg, MS.

Gravens, M. B. 1988. "Use of Hindcast Wave Data for Estimation of Longshore Sediment Transport," *Proceedings of the Symposium on Coastal Water Resources*, American Water Resources Association, Wilmington, NC, pp. 63-72.

Shore Protection Manual. 1984. 4th ed., 2 Vols., US Army Engineer Waterways Experiment Station, Coastal Engineering Research Center, US Government Printing Office, Washington, DC, Chapter 4, pp. 89-107.

Vitale, P. 1980. "A Guide for Estimating Longshore Transport Rate Using Four SPM Methods," CERC CETA 80-6, US Army Engineer Waterways Experiment Station, Vicksburg, MS.

Wave Information Studies of US Coastlines

- Corson, W. D., Able, C. E., Brooks, R. M., Farrar, P. D., Groves, B. J., Payne, J. B., McAneny, D. S., and Tracy, B. A. 1987. "Pacific Coast Hindcast Phase II Wave Information," Wave Information Studies of US Coastlines, WIS Report 16, US Army Engineer Waterways Experiment Station, Vicksburg, MS.
- Driver, D. B., Reinhard, R. D., and Hubertz, J. M. 1991. "Hindcast Wave Information for the Great Lakes: Lake Erie," Wave Information Studies of US Coastlines, WIS Report 22, US Army Engineer Waterways Experiment Station, Vicksburg, MS.
- Driver, D. B., Reinhard, R. D., and Hubertz, J. M. 1992. "Hindcast Wave Information for the Great Lakes: Lake Superior," Wave Information Studies of US Coastlines, WIS Report 23, US Army Engineer Waterways Experiment Station, Vicksburg, MS.
- Hubertz, J. M., and Brooks, R. M. 1989. "Gulf of Mexico Hindcast Wave Information," Wave Information Studies of US Coastlines, WIS Report 18, US Army Engineer Waterways Experiment Station, Vicksburg, MS.
- Hubertz, J. M., Driver, D. B., and Reinhard, R. D. 1991. "Hindcast Wave Information for the Great Lakes: Lake Michigan," Wave Information Studies of US Coastlines, WIS Report 24, US Army Engineer Waterways Experiment Station, Vicksburg, MS.
- Jensen, R. E. 1983. "Atlantic Coast Hindcast, Shallow-Water Significant Wave Information," Wave Information Studies of US Coastlines, WIS Report 9, US Army Engineer Waterways Experiment Station, Vicksburg, MS.
- Reinhard, R. D., Driver, D. B., and Hubertz, J. M. 1991. "Hindcast Wave Information for the Great Lakes: Lake Huron," Wave Information Studies of US Coastlines, WIS Report 26, US Army Engineer Waterways Experiment Station, Vicksburg, MS.
- Reinhard, R. D., Driver, D. B., and Hubertz, J. M. 1991. "Hindcast Wave Information for the Great Lakes: Lake Ontario," Wave Information Studies of US Coastlines, WIS Report 25, US Army Engineer Waterways Experiment Station, Vicksburg, MS.

NUMERICAL SIMULATION OF TIME-DEPENDENT BEACH AND DUNE EROSION

TABLE OF CONTENTS

Description	6-2-1
Input	6-2-1
Output	6-2-1
Plot Output File 1	6-2-2
Plot Output File 2	6-2-2
Procedure	6-2-2
Data Entry Options Menu	6-2-3
Initial Case Data Entry	6-2-3
Edit Case in External File: XSHORE1.IN	6-2-3
Activity Menu	6-2-3
Begin Computations	6-2-4
General Time & Output Specifications	6-2-4
Interval Output Time Requestor	6-2-5
Specific Output Times Requestor	6-2-5
Beach Characteristics Data Entry	6-2-6
Actual Beach Profile Requestor	6-2-7
Enter/Edit/View Profile Data	6-2-7
Read an ISRP Data File	6-2-8
Select an ISRP Profile	6-2-9
Format of an ISRP Data File	6-2-10
Generic Beach Profile Requestor	6-2-12
Water Level Data Entry	6-2-12
Tabulated Data	6-2-13
Constituent Tide Data	6-2-13
Wave Parameter Data Entry	6-2-14
Plot Output Data	6-2-14
Application Restrictions, Requirements, and Limitations	6-2-15
Example Problems	6-2-16
Example 1 - Generic Profile with Constituent Tide Data	6-2-16
Input	6-2-16
General Time & Output Specifications Data Entry	6-2-16
Beach Characteristics Data Entry	6-2-16
Water Level Data Entry	6-2-17
Wave Parameter Data Entry	6-2-17
Output	6-2-17
Plot Output File 1	6-2-17
Plot Output File 2	6-2-20
Example 2 - Generic Profile with No Water Level Data	6-2-21
Input	6-2-21
General Time & Output Specifications Data Entry	6-2-21
Beach Characteristics Data Entry	6-2-21
Generic Profile Data	6-2-21
Wave Parameter Data Entry	6-2-21

NUMERICAL SIMULATION OF TIME-DEPENDENT BEACH AND DUNE EROSION

Output	6-2-22
Plot Output File 1	6-2-22
Plot Output File 2	6-2-24
Example 3 - Generic Profile with Tabulated Water Data	6-2-25
Input	6-2-25
General Time & Output Specifications Data Entry	6-2-25
Beach Characteristics Data Entry	6-2-25
Water Level Data Entry	6-2-26
Wave Parameter Data Entry	6-2-26
Output	6-2-26
Plot Output File 1	6-2-26
Plot Output File 2	6-2-29
Example 4 - Actual Profile Data with No Water Level Data	6-2-30
Input	6-2-30
General Time & Output Specifications Data Entry	6-2-30
Beach Characteristics Data Entry	6-2-30
Actual Profile Data	6-2-31
Wave Parameter Data Entry	6-2-31
Output	6-2-32
Plot Output File 1	6-2-32
Plot Output File 2	6-2-34
References and Bibliography	6-2-35

NUMERICAL SIMULATION OF TIME-DEPENDENT BEACH AND DUNE EROSION

DESCRIPTION

This application is a numerical beach and dune erosion model that predicts the evolution of an equilibrium beach profile from variations in water level and breaking wave height as occur during a storm. The model is one-dimensional (only onshore-offshore sediment transport is represented). It is based on the theory that an equilibrium profile results from uniform wave energy dissipation per unit volume of water in the surf zone. The general characteristics of the model are based on a model described by Kriebel (1982, 1984a, 1984b, 1986). Because of the complexity of this methodology and the input requirements, familiarization with the above references is strongly recommended.

INPUT

The input requirements of this application consist of four general types of information.

- General data describing temporal data to run the model.
- Beach characteristics (actual prestorm profile or a generic profile).
- Changes in water elevation relative to mean water level due to storm surge and/or tides.
- Wave parameters (height, period, direction) and associated water depth.

Data input to this application is accomplished through numerous input screens or through data saved in external files, i.e., ACES trace file or the Interactive Survey Reduction Program (ISRP) (Birkemeier, 1984) beach profile output file. Detailed lists of the screens and input parameters are presented in the *Procedure* section of this document.

OUTPUT

Results from this application are written to the plot output files (1, 2). The contents and organization of output data in the plot output files are summarized below. In addition, this application generates one plot (see section titled **Plot Output Data**).

Plot Output File 1

This file contains simulated profile data representing the original profile and evolving, time-dependent profiles. Each point along the profile is defined by some distance seaward of a baseline and a corresponding elevation. Profiles are reported at the *Tabular Output Time Interval*. Plot output file 1 is written in the following format:

Field	Columns	Format	Data
1	1-9	F9.0	Distance Seaward from Baseline (X Coordinate)
2	18-23	F6.2	Elevation (Corresponding Y Coordinate)

Plot Output File 2

This file contains a table consisting of changes in sand volume and changes (advance/retreat) in position of the 0-, +5-, +10-, and +15-ft contours. Erosion statistics are reported at the *Tabular Output Time Interval*.

Field	Columns	Format	Data
1	8-11	I4	Time (hours) when erosion statistics are reported
2	19-28	F10.2	Change in sand volume above mean water level
3	34-43	F10.2	Change in shoreline position at the 0-ft contour
4	44-53	F10.2	Change in shoreline position at the +5-ft contour
5	54-63	F10.2	Change in shoreline position at the +10-ft contour
6	64-73	F10.2	Change in shoreline position at the +15-ft contour

PROCEDURE

This application provides only a Single Case Mode. The Multiple Case Mode is not available. The Single Case Mode requires interaction with the application and provides three options of interactive participation. The first option allows entering a new data set via screen input, the second option allows editing of data sets read from an external ACES trace file, and the third option allows editing of X,Y profile coordinates read from an external ISRP output file.

Single Case Mode

The bulleted items in the following lists indicate potentially optional instruction steps. Any application in ACES may be executed in a given session without quitting the program. The bulleted items provide instructions for accessing the application from various menu areas of the ACES Program. Ignore bulleted instruction steps that are not applicable.

- Press **F1** on the Main Menu to select Single Case Mode.
- Fill in the highlighted input fields on the General Specifications screen (or leave the default values). Press **F1** when all data on this screen are correct.
- Press **F6** on the Functional Area Menu to select Littoral Processes.
- Press **F2** on the Littoral Processes Menu to select Numerical Simulation of Time-Dependent Beach and Dune Erosion.

Data Entry Options Menu

This menu provides two options of interactive participation with the application.

F1 Initial Case Data Entry

Use this option to enter an initial (new) set of data. These data will be written to the *Trace Output* file (default name **TRACE.OUT**) and become available for subsequent editing and use.

Alt F1 Edit Case in External File: XSHORE1.IN

Use this option to access and modify data saved in an external ACES trace file. This external data file is created by saving (or copying) a *trace file* from a previous execution of this application. The format and contents of the *trace file* for this application match exactly the requirements of this input file. The default input file name is **XSHORE1.IN**, but other file names (including path name) are acceptable. After entering the file name, press **ENTER** to accept this file. *For more information on files, see the section of this manual entitled "General Instructions and Information."*

Activity Menu

The Activity Menu is a pivotal point from which all options for Single Case data entry, modification, and execution are accessible. The options are:

- F1** Begin Computations.
- F2** General Time & Output Specifications Data Entry.
- F3** Beach Characteristics Data Entry.
- F4** Water Level Data Entry.
- F5** Wave Parameter Data Entry.
- F6** Plot Output Data.
- F10** Exit Menu.

Each option and the required data are described below.

(F1) Begin Computations

Use this option only after all data have been entered.

(F2) General Time & Output Specifications

This screen provides for input of general parameters required to run the application. Values for all parameters listed are required.

<u>Item</u>	<u>Units</u>	<u>Data Range</u>
Simulation start time:		
Year		1900 to 2050
Month		1 to 12
Day		1 to 31
Hour		0 to 24
Length of simulation	hr	1 to 120
Tabular Output Time		interval or specific times

Select a *Tabular Output Time* by moving the cursor to the desired type and pressing . Choices available are:

- Interval
- Specific Times

Selecting either of these choices will display a *requestor* for further input. The format and data requirements of these *requestors* are described next.

Interval Output Time Requestor

Enter an integer value identifying a constant output time *interval* for results to be written to the plot output files. The range of values allowed for the constant *interval* is:

<u>Item</u>	<u>Units</u>	<u>Data Range</u>
Interval	hours	1 to 120

After entering an interval value, press one of the following keys to select the next appropriate action:

F1 Accept Data & Exit Requestor.

Alt F10 Return to Activity Menu.

Specific Output Times Requestor

Enter as many as 30 integer values indicating the *specific times* from beginning of simulation for results to be written to the plot output files. The range of values allowed for the *specific times* is:

<u>Item</u>	<u>Units</u>	<u>Data Range</u>
Specific Times	hours	1 to 120

After entering the desired specific times, press one of the following keys to select the next appropriate action:

Alt F1 More Input.

NOTE: Ten values can be displayed/entered on a screen. Press **Alt F1** to re-invoke the screen for subsequent values.

F1 Accept Data & Exit Requestor.

Alt F10 Return to Activity Menu.

F3 Beach Characteristics Data Entry

This option provides an interactive capability to enter new or edit existing input of an original prestorm beach profile. The beach profile may be described by one of two methods:

1. Actual profile - A series of X,Y coordinate pairs that define points along the profile. The X coordinate represents distance seaward from a baseline. The Y coordinate represents a corresponding elevation relative to mean water level (MWL = 0). In addition, the user defines elevations for the top of dune and berm and mean grain size.
2. Generic profile - A schematic representation of a simple berm-dune and offshore system. See Figure 6-2-1 for definition of profile terms.

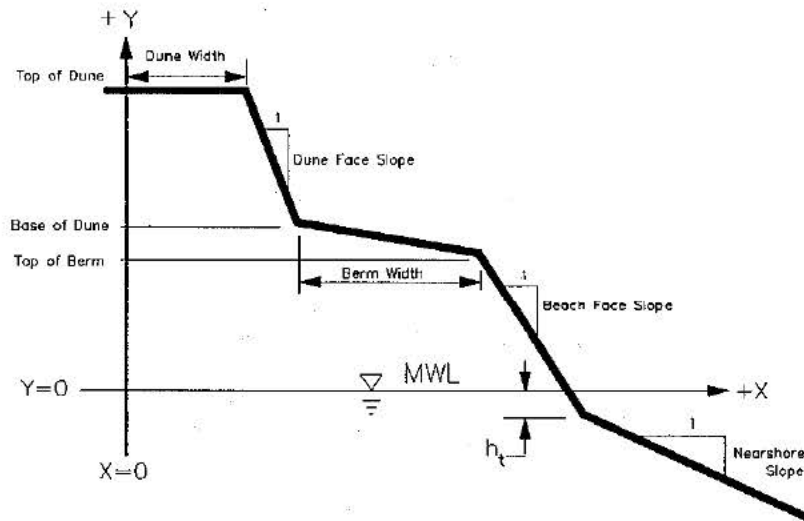

Figure 6-2-1. Idealized Berm, Dune, and Offshore System

The following list describes parameters on the *General Beach Characteristics* screen with corresponding units and ranges of values recognized by this application:

<u>Item</u>	<u>Units</u>	<u>Data Range</u>	
Elevation at top of dune	ft,m	0.0	to 9,999.0
Elevation at base of dune	ft,m	0.0	to below dune top
Elevation at top of berm	ft,m	0.0	to 9,999.0
Dune width from baseline	ft,m	0.0	to 100.0
Berm width	ft,m	0.0	to 500.0
Mean grain size	mm	0.1	to 0.5
Profile		actual	or generic

Select a beach profile by moving the cursor to the desired type and pressing . The choices are:

- Actual Beach Profile
- Generic Beach Profile

Selecting either of these will display *requestors* for further input. The format and data requirements of these *requestors* are described next.

Actual Beach Profile Requestor

When this option is selected, the *Actual Beach Profile Point Data Entry Options* requestor is displayed. This *requestor* invokes other *requestors* that collect choices and input to complete an actual beach profile definition for this application. As a minimum, these parameters are required to define an actual profile:

- Elevations at top of dune and berm.
- Mean grain size.
- 20 survey points (X,Y coordinate pairs) along the profile.

The *Actual Beach Profile Data Entry Options* requestor provides these choices to complete a profile definition:

- Enter/Edit/View Profile Data.
- Read an ISRP Data File.
- Select an ISRP Profile/ Survey Number.

To make a selection, move the cursor to the desired choice and press . Selecting a choice will display *requestors* for further input.

Enter/Edit/View Profile Data

This choice invokes the *Actual Beach Profile Point Data* requestor that allows for interactively entering a data set of survey points along a profile, editing a profile data set, or viewing a profile data set. The following list describes parameters on the *Actual Beach Profile Point Data* requestor with their corresponding units and range of data recognized by this application:

<u>Item</u>	<u>Units</u>	<u>Data Range</u>
Profile data units	ft,m	
Distance from baseline (X)	ft,m	0.0 to 4,000.0
Elevation (Y)	ft,m	-999.0 to 9,999.0

The first survey point on the profile should have a *Distance from baseline (X)* value of zero, and the corresponding *Elevation (Y)* value should match the value for *Elevation at Top of Dune (General Beach Characteristics)*.

NOTE: Minimum input parameters required to define an actual profile are *Elevations at Top of Dune and Berm, Mean Grain Size*, and 20 survey points (X,Y coordinate pairs) along the profile.

Press one of the following keys to select the next appropriate action:

(Alt)(F1) Display/Enter More Data.

NOTE: Twenty survey points can be displayed/entered on a screen. Press **(Alt)(F1)** to re-invoke the screen for subsequent points. The maximum number of X/Y pairs allowed to define the profile is 200.

(F1) Accept Data & Exit.

(Alt)(F10) Exit Requestor (do not accept data).

Read an ISRP Data File

If available, an ISRP data file may be input as an alternative to interactively keying in actual profile data or reading them from an external ACES trace file. This choice provides a *requestor* as a mechanism for declaring the name of the external file containing two-dimensional profile data in ISRP *Edit-2* format. Typically, data have been saved in the file from a previous execution of ISRP. The default ISRP file name is **ISRP1.IN**, but other file names (including path name) are acceptable. After entering the file name, press **(Enter)** to accept this file. For more information on ISRP files, see the following section, titled *Format of an ISRP Data File*.

After specifying the name of the file, press one of the following keys to select the appropriate action:

(F1) Accept Data & Exit Requestor.

NOTE: Use this option to open and read the ISRP file. A message, "Please Wait - Reading data file," is displayed at the bottom of the screen until the file is read.

Only the first 216 profile definitions in the file are read by this application. If the file contains more definitions, they are ignored. A message indicating this limitation is displayed at the bottom of the screen. *This is not an error, the program will continue accepting commands.*

A maximum of 200 survey points along the profile are read by this application. Any additional points on that profile are skipped. A message to that effect is displayed at the bottom of the screen. *This is not an error, the program will continue to read the file.*

Upon successfully reading the file, a profile data set can be selected and edited using procedures described in *Select an ISRP Profile* and *Enter/Edit/View Profile Data* sections of this manual.

Alt F10 Exit Requestor (do not accept data).

Select an ISRP Profile

This choice invokes the *Select One ISRP Profile Number* requestor that allows selecting an ISRP profile by tagging the desired profile number. All profile numbers identifying profiles read from the ISRP file are displayed as an aid for selection and tagging. To tag a profile for selection, move the cursor to the desired choice and press **⊗**. Only one profile selection is needed for each computation.

When selection is complete, press one of the following keys to select the next appropriate action:

Alt F1 Next Screen.

NOTE: As many as 60 ISRP profile names are displayed on a screen. If more than 60 are read from the ISRP file, press **Alt F1** to display more profile names on the next screen. A maximum of 216 names can be displayed.

F1 Accept Data, Exit Requestor.

Alt F10 Exit Requestor (selection is not accepted).

Format of an ISRP Data File

The ISRP primary output is a file defining profile line data sets (distance offshore and elevation) for a specific area in ISRP *Edit-2* format. The ISRP has more than one data file format; however, only *Edit-2* type data files are recognized by this application.

The first record in an ISRP *Edit-2* type data file is a *Header* record that provides general information about data in the file. Other records in the file define profile data sets.

The following sections describe the records including format, parameters, and corresponding range of values recognized by this application. See Figure 6-2-2 for a sample of an ISRP *Edit-2* file.

Header Record

Column	Type	Item	Data Range
1-2	Integer	Header Record Identifier	00
11	Integer	Edit-2 Identifier	1
12	Integer	Number of places to right of decimal for distance coordinates	0 to 3
13	Integer	Number of places to right of decimal for elevation coordinates	0 to 3
14-15	Character	Abbreviation for units of measurements of recorded data	ft or m
16-19	Character	Vertical datum reference	MSL NGVD
20-69	Character	Description	
70-75	Integer	Date file was created	yyymmdd
77-80	Character	Initials of person creating file	

Profile Data Set Record

Column	Type	Item	Data Range
1-2	Character	Locality code	any characters
3-5	Integer	Profile line number	1 to 999
6-9	Integer	Survey identification number	1 to 9999
10	Character	First record of profile definition	1
11-16	Integer	Date of survey	yyymmdd
18-21	Integer	Time of survey (24-hour clock)	0001 to 2400
22-24	Integer	Number of X,Y pairs in profile definition	20 to 200
25-29	Integer	Minimum elevation on profile	-9999 to 99999
41-45	Integer	Distance coordinate	0 to 99999
46-50	Integer	Elevation coordinate	-9999 to 99999
51-55	Integer	Distance coordinate	0 to 99999
56-60	Integer	Elevation coordinate	-9999 to 99999
61-65	Integer	Distance coordinate	0 to 99999
66-70	Integer	Elevation coordinate	-9999 to 99999
71-75	Integer	Distance coordinate	0 to 99999
76-80	Integer	Elevation coordinate	-9999 to 99999

Profile Data Set Continuation Record

Column	Type	Item	Data Range
1-2	Character	Locality code	any characters
3-5	Integer	Profile line number	1 to 999
6-9	Integer	Survey identification number	1 to 9999
10	Character	Continuation record counter	2 to 9 and A to Z
11-15	Integer	Distance coordinate	0 to 99999
16-20	Integer	Elevation coordinate	-9999 to 99999
21-25	Integer	Distance coordinate	0 to 99999
26-30	Integer	Elevation coordinate	-9999 to 99999
31-35	Integer	Distance coordinate	0 to 99999
36-40	Integer	Elevation coordinate	-9999 to 99999
41-45	Integer	Distance coordinate	0 to 99999
46-50	Integer	Elevation coordinate	-9999 to 99999
51-55	Integer	Distance coordinate	0 to 99999
56-60	Integer	Elevation coordinate	-9999 to 99999
61-65	Integer	Distance coordinate	0 to 99999
66-70	Integer	Elevation coordinate	-9999 to 99999
71-75	Integer	Distance coordinate	0 to 99999
76-80	Integer	Elevation coordinate	-9999 to 99999

00	101ft	Little River Inlet data	MAC
LR 50	21810430	1200 74 -181	0 93 20 127 25 117 35 98
LR 50	22 50	95 75 85 100 60 125 46 150 36 175 31 200 27	
LR 50	23 225	23 250 18 275 15 300 12 325 6 350 1 375 -6	
LR 50	24 400	-11 425 -17 450 -13 500 -42 550 -43 600 -42 650 -53	
LR 50	25 700	-61 750 -71 800 -71 850 -85 900 -90 950 -96 1000 -99	
LR 50	26 1050	-109 1100 -118 1150 -120 1200 -115 1250 -125 1300 -129 1350 -133	
LR 50	27 1400	-135 1450 -134 1500 -140 1550 -141 1600 -142 1650 -150 1700 -148	
LR 50	28 1750	-150 1800 -153 1850 -155 1900 -157 1950 -164 2000 -163 2050 -165	
LR 50	29 2100	-160 2150 -174 2200 -165 2250 -173 2300 -172 2350 -175 2400 -168	
LR 50	2A 2450	-169 2500 -171 2550 -171 2600 -171 2650 -172 2700 -176 2750 -176	
LR 50	2B 2800	-175 2850 -180 2900 -178 2950 -181 3000 -180 3050 -180 3100 -180	
LR 50	31810715	1200 76 -193	0 92 20 26 35 96 40 95
LR 50	32 60	85 80 76 100 60 120 49 140 37 160 35 180 33	
LR 50	33 200	29 220 22 240 26 260 21 280 15 300 9 320 3	
LR 50	34 340	-2 360 -8 380 -13 400 -15 420 -11 440 -11 460 -14	
LR 50	35 480	-29 500 -40 550 -40 600 -44 650 -60 700 -63 750 -80	
LR 50	36 800	-86 850 -90 900 -104 950 -109 1000 -102 1050 -116 1100 -121	
LR 50	37 1150	-128 1200 -133 1250 -132 1300 -138 1350 -144 1400 -143 1450 -150	
LR 50	38 1500	-152 1550 -154 1600 -152 1650 -158 1700 -159 1750 -159 1800 -160	
LR 50	39 1850	-159 1900 -168 1950 -162 2000 -170 2050 -170 2100 -168 2150 -172	
LR 50	3A 2200	-170 2250 -173 2300 -173 2350 -174 2400 -180 2450 -178 2500 -183	
LR 50	3B 2550	-180 2600 -181 2650 -185 2700 -190 2750 -188 2800 -188 2850 -190	
LR 50	3C 2900	-191 2950 -193 0 0 0 0 0 0 0 0 0 0 0	
LR 50	41811015	1200 67 -200	0 93 20 127 25 118 50 94
LR 50	42 75	79 100 63 125 53 150 40 175 32 200 29 225 19	
LR 50	43 250	15 275 10 300 5 325 -1 350 -4 375 -8 400 -20	
LR 50	44 450	-71 500 -82 550 -86 600 -92 650 -100 700 -104 750 -117	
LR 50	45 800	-109 850 -126 900 -121 950 -125 1000 -130 1050 -137 1100 -140	
LR 50	46 1150	-140 1200 -143 1250 -145 1300 -146 1350 -148 1400 -153 1450 -147	
LR 50	47 1500	-160 1550 -153 1600 -160 1650 -161 1700 -160 1750 -159 1800 -168	
LR 50	48 1850	-161 1900 -169 1950 -164 2000 -172 2050 -169 2100 -171 2150 -180	
LR 50	49 2200	-171 2250 -179 2300 -180 2350 -175 2400 -180 2450 -183 2500 -182	
LR 50	4A 2550	-181 2600 -184 2650 -181 2700 -190 2750 -191 2800 -190 2850 -200	
LR 50	51820115	1200 60 -190	50 93 75 79 100 66 125 49
LR 50	52 150	40 175 34 200 28 225 23 250 19 275 14 300 9	
LR 50	53 325	7 350 3 375 -2 400 -7 450 -82 500 -88 550 -97	
LR 50	54 600	-102 650 -104 700 -114 750 -120 800 -120 850 -123 900 -132	
LR 50	55 950	-134 1000 -136 1050 -140 1100 -145 1150 -149 1200 -147 1250 -153	
LR 50	56 1300	-157 1350 -158 1400 -155 1450 -160 1500 -161 1550 -159 1600 -168	
LR 50	57 1650	-167 1700 -163 1750 -170 1800 -164 1850 -168 1900 -172 1950 -172	
LR 50	58 2000	-170 2050 -177 2100 -176 2150 -177 2200 -179 2250 -180 2300 -186	
LR 50	59 2350	-182 2400 -188 2450 -185 2500 -186 2550 -187 2600 -190 2650 -190	

Figure 6-2-2. Sample of an ISRP Edit-2 File

Generic Beach Profile Requestor

This choice invokes the *Generic Beach Profile Parameters* requestor that collects additional input for completing a schematic representation of an idealized profile. When *Elevation At Top of Dune* is entered, then *Elevation At Base of Dune* and *Cotangent of Dune Face Slope* are required. When *Elevation At Top of Berm* is entered, then *Cotangent of Beach Slope* is required. In addition, *Mean Grain Size* and *Cotangent of Nearshore Slope* are always required. The following list describes parameters on the *Generic Beach Profile Parameters* requestor with their corresponding units and range of data recognized by this application:

<u>Item</u>	<u>Data Range</u>
Cotangent of dune face slope	1.0 to 10.0
Cotangent of beach face slope	1.0 to 20.0
Cotangent of nearshore slope	20.0 to 60.0

Press one of the following keys to select the next appropriate action:

(F1) Accept Data & Exit Requestor.

(Alt)(F10) Exit Requestor (do not accept data).

(F4) Water Level Data Entry

This series of screens provides for input of water level variations for the model. Water levels may be described by one or both of the following methods:

1. *Tabulated* entries (100 maximum) collected by a tide gage at a constant sampling interval.
2. Tides as a *constituent* tide record with an amplitude and corresponding epoch for any of 37 constituents. The major tidal constituents accepted by this application are listed in Table A-5 in Appendix A.

NOTE: The final water level used in the model will be the sum of *tabulated* entries and a *constituent* tide record. The model will also run without water level data.

From the menu on the screen *Identify Type of Time-Series Water Level Data*, press:

- (F1) To access the screen for entering tabulated data.
 (F2) To access the screen for entering constituent tide data.

Tabulated Data

<u>Item</u>	<u>Units</u>	<u>Data Range</u>
Δt for hydrograph input	hr	1.0 to 120.0
Water level units	ft,m	
Water levels _m ($m = 1 \dots M, M \leq 100$)	ft,m	0.0 to 20.0

NOTE: Enter water levels relative to Mean Water Level (MWL) = 0. First water level must be 0.0. Each screen will accept a maximum of 20 values.

Press one of the following keys to select the next appropriate action:

- (F1) More Input.

NOTE: Use this option to continue *tabulated* input (maximum 100 values).

- (Alt)(F10) Return.

Constituent Tide Data

<u>Item</u>	<u>Units</u>	<u>Data Range</u>
Gage longitude	deg WEST	-180.0 to 180.00
Amplitude units	ft,m	
Amplitude of individual constituent _n	ft,m	0.0 to 999.99
Epoch of individual constituent _n	deg	0.0 to 360.00

NOTE: The names of 37 common harmonic constituents (see Table A-5, Appendix A) are displayed on a series of screens. Place the values of amplitude and epoch at the appropriate desired constituent name.

Press one of the following keys to select the next appropriate action:

F1 More Input.

NOTE: Use this option to continue additional *constituent* input on subsequent screens.

Alt F10 Return.

F5 Wave Parameter Data Entry

This series of screens provides for input of wave parameters and an associated water depth for the model. Wave parameters are collected at a constant time interval and constant water depth.

<u>Item</u>	<u>Units</u>	<u>Data Range</u>
Δt for wave parameters	hr	1.0 to 120.00
Wave height units	ft,m	
Water depth	ft,m	5.0 to 9,999.99
Wave height	ft,m	1.0 to 30.00
Wave period	sec	1.0 to 30.00
Wave crest angle	deg	0.0 to 89.00

Press one of the following keys to select the next appropriate action:

F1 More Input.

NOTE: Ten wave records can be displayed/entered on a screen. Press **ALT F1** to re-invoke the screen for subsequent values.

Alt F10 Return to Activity Menu.

F6 Plot Output Data

This application generates one plot with two curves (see Figure 6-2-3). The two curves are:

- Original profile.
 - Computer profile at the end of the simulation time.
-

APPLICATION RESTRICTIONS, REQUIREMENTS, AND LIMITATIONS

Listed below are some restrictions, requirements, and limitations of this application.

- If the profile used in this application is a *Generic* profile, then the water depth at the gage must be at least twice the maximum wave height that is used.
- If the profile that is used is an *Actual* profile, then the maximum profile depth must be equal to or greater than twice the maximum wave height that is used.
- If the entire profile becomes submerged during execution of this application, then the program will stop and the user will be requested to check the *water depth* entry and **Water Level Data Entry** option.
- This application can be used to determine the beach response profile in front of a seawall by assuming that the seawall is located at $X = 0$ on the profile.
- Calculations over the horizontal grid of the model are carried out to a maximum depth of 45 ft.

EXAMPLE PROBLEMS

Example 1 - Generic Profile with Constituent Tide Data

Input

All input is accomplished through screens accessible from the **Activity Menu**.

F2) General Time & Output Specifications Data Entry

<u>Item</u>	<u>Value</u>	<u>Units</u>
Simulation start time:		
Year	1989	
Month	1	
Day	10	
Hour	10.00	
Length of simulation	20.00	hr
Tabular output time (Interval)	2.00	hr

F3) Beach Characteristics Data Entry

<u>Item</u>	<u>Value</u>	<u>Units</u>
Elevation at top of dune	20.000	ft
Elevation at base of dune	6.000	ft
Elevation at top of berm	6.000	ft
Dune width from baseline	50.000	ft
Berm width	100.000	ft
Mean grain size	0.220	mm
Profile	GENERIC	

Generic Profile Data

<u>Item</u>	<u>Value</u>	<u>Units</u>
Cotangent of dune face slope	2.000	
Cotangent of beach face slope	10.000	
Cotangent of nearshore slope	20.000	

F4) Water Level Data Entry**F2) Constituent Tide Data (see Table A-5, Appendix A)**

<u>Item</u>	<u>Value</u>	<u>Units</u>
Gage longitude	75.00	deg WEST
Amplitude units		ft
Amplitude of individual constituent _n (M4)	4.00	ft
Epoch of individual constituent _n (M4)	90.00	deg

NOTE: All other common harmonic constituents are 0.0 for this example.

F5) Wave Parameter Data Entry

<u>Item</u>	<u>Value</u>	<u>Units</u>
Δt for wave parameters	20.00	hr
Wave height units		ft
Water depth	60.00	ft
Wave height	8.00	ft
Wave period	8.00	sec
Wave crest angle	10.00	deg

Output

Results from this application are written to two plot output files. In addition, this application generates one screen plot.

Plot Output File 1

This file contains simulated profile data representing the original profile and evolving, time-dependent profiles. Each point along the profile is defined by some distance seaward of a baseline and a corresponding elevation. Profiles are reported at the *Tabular Output Time Interval*. Table 6-2-1 is a partial listing of plot output file 1 (default name **PLOTDAT1.OUT**). Figure 6-2-3 is a plot comparing the original profile with the 20-hr profile.

Table 6-2-1
 Listing of Plot Output File 1 for Example Problem 1
 Original Profile Data

Dist. Seaward from Baseline (ft)	Elev.(ft)
0.	20.00
4.	20.00
8.	20.00
↓	↓
212.	2.40
216.	2.00
220.	1.60
224.	1.20
228.	0.80
232.	0.40
↓	↓
1128.	-44.60
1132.	-44.80
1136.	-45.00

Profile Data at 2 hr

Dist. Seaward from Baseline (ft)	Elev.(ft)
0.	20.00
4.	20.00
8.	20.00
↓	↓
212.	2.10
216.	1.46
220.	1.08
224.	0.78
228.	0.49
232.	0.22
↓	↓
1128.	-44.60
1132.	-44.80
1136.	-45.00

(Table 6-2-1 Continued on the Next Page)

(Table 6-2-1 Concluded)

Profile Data at 20 hr

Dist. Seaward from Baseline (ft)	Elev.(ft)
0.	20.00
4.	20.00
8.	20.00
↓	↓
204.	1.63
208.	1.26
212.	0.91
216.	0.59
220.	0.29
224.	0.00
228.	-0.28
232.	-0.55
236.	-0.81
↓	↓
1128.	-44.60
1132.	-44.80
1136.	-45.00

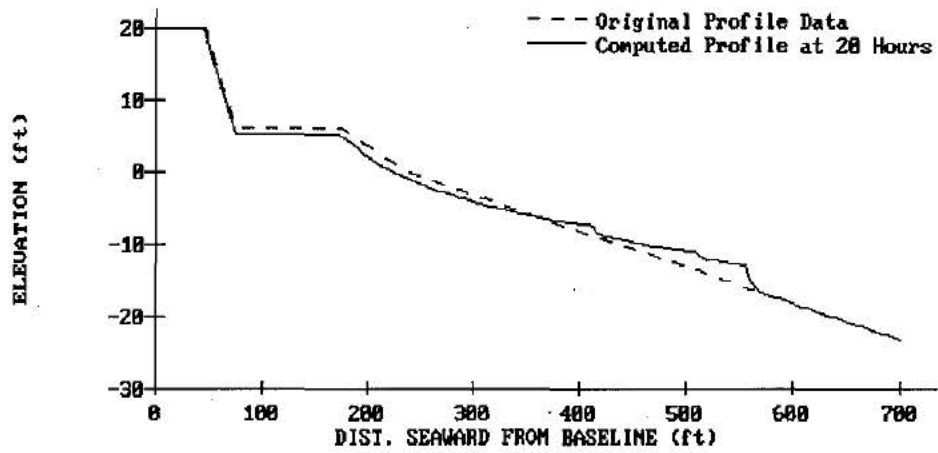

Figure 6-2-3. Profile Change After 20 Hr

Plot Output File 2

This file contains a table consisting of changes in sand volume and changes (advance/retreat) in position of the 0-, +5-, +10-, and +15-ft contours. Erosion statistics are reported at the *Tabular Output Time Interval*. Table 6-2-2 is a listing of plot output file 2 (default name **PLOTDAT2.OUT**).

Table 6-2-2
Listing of Plot Output File 2 for Example Problem 1

Hour	Change in Volume (yd ³ /ft)	Contour Change (ft)			
		0	+5	+10	+15
2	-1.05	-0.63	-2.98	-0.14	-0.14
4	-0.94	-0.40	-2.84	-0.11	-0.11
6	-1.13	-5.13	-2.94	-0.14	-0.14
8	-2.87	-6.28	-4.84	-0.52	-0.52
10	-2.80	-6.12	-4.73	-0.49	-0.49
12	-2.96	-7.21	-4.97	-0.54	-0.54
14	-4.87	-9.26	-8.05	-1.16	-1.16
16	-4.87	-10.43	-8.04	-1.16	-1.16
18	-4.82	-10.37	-7.97	-1.14	-1.14
20	-6.80	-12.05	-11.66	-1.74	-1.74

(Example 1 Concluded)

Example 2 - Generic Profile with No Water Level Data**Input**

All input is accomplished through screens accessible from the **Activity Menu**.

F2) General Time & Output Specifications Data Entry

<u>Item</u>	<u>Value</u>	<u>Units</u>
Simulation start time:		
Year	1989	
Month	1	
Day	17	
Hour	3.00	
Length of simulation	20.00	hr
Tabular output time (Interval)	2.00	hr

F3) Beach Characteristics Data Entry

<u>Item</u>	<u>Value</u>	<u>Units</u>
Elevation at top of dune	20.000	ft
Elevation at base of dune	6.000	ft
Elevation at top of berm	6.000	ft
Dune width from baseline	50.000	ft
Berm width	100.000	ft
Mean grain size	0.220	mm
Profile	GENERIC	

Generic Profile Data

<u>Item</u>	<u>Value</u>	<u>Units</u>
Cotangent of dune face slope	2.000	
Cotangent of beach face slope	10.000	
Cotangent of nearshore slope	20.000	

F5) Wave Parameter Data Entry

<u>Item</u>	<u>Value</u>	<u>Units</u>
Δt for wave parameters	20.00	hr

Wave height units		ft
Water depth	60.00	ft
Wave height	8.00	ft
Wave period	8.00	sec
Wave crest angle	10.00	deg

Output

Results from this application are written to two plot output files. In addition, this application generates one screen plot.

Plot Output File 1

This file contains simulated profile data representing the original profile and evolving, time-dependent profiles. Each point along the profile is defined by some distance seaward of a baseline and a corresponding elevation. Profiles are reported at the *Tabular Output Time Interval*. Table 6-2-3 is a partial listing of plot output file 1 (default name **PLOTDAT1.OUT**). Figure 6-2-4 is a plot comparing the original profile with the 20-hr profile.

Table 6-2-3
Listing of Plot Output File 1 for Example Problem 2
Original Profile Data

Dist. Seaward from Baseline (ft)	Elev.(ft)
0.	20.00
4.	20.00
8.	20.00
↓	↓
208.	2.80
212.	2.40
216.	2.00
220.	1.60
224.	1.20
228.	0.80
232.	0.40
↓	↓
1128.	-44.60
1132.	-44.80
1136.	-45.00

(Table 6-2-3 Continued on the Next Page)

(Table 6-2-3 Concluded)

Profile Data at 2 hr

Dist. Seaward from Baseline (ft)	Elev.(ft)
0.	20.00
4.	20.00
8.	20.00
↓	↓
208.	2.78
212.	2.38
216.	1.98
220.	1.58
224.	1.18
228.	0.78
232.	0.38
↓	↓
1128.	-44.60
1132.	-44.80
1136.	-45.00

Profile Data at 20 hr

Dist. Seaward from Baseline (ft)	Elev.(ft)
0.	20.00
4.	20.00
8.	20.00
↓	↓
208.	1.59
212.	1.19
216.	0.79
220.	0.39
224.	-0.01
228.	-0.61
232.	-0.97
↓	↓
1128.	-44.60
1132.	-44.80
1136.	-45.00

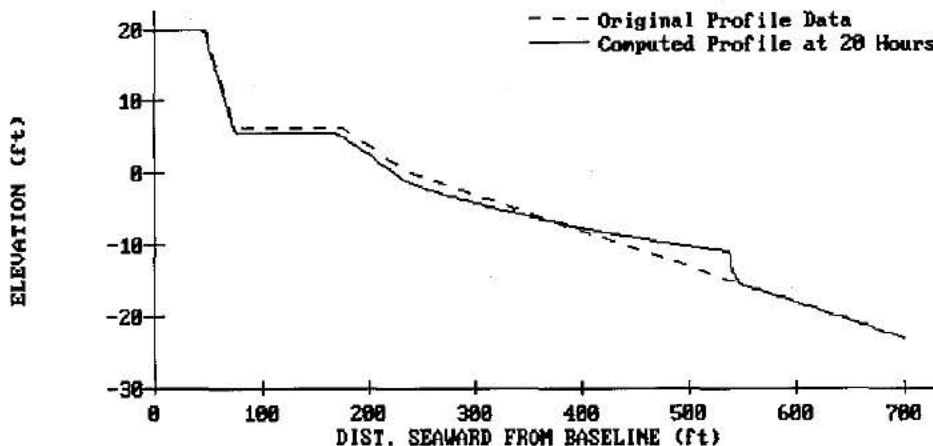

Figure 6-2-4. Profile Change After 20 Hr

Plot Output File 2

This file contains a table consisting of changes in sand volume and changes (advance/retreat) in position of the 0-, +5-, +10-, and +15-ft contours. Erosion statistics are reported at the *Tabular Output Time Interval*. Table 6-2-4 is a listing of plot output file 2 (default name **PLOTDAT2.OUT**).

Table 6-2-4
Listing of Plot Output File 2 for Example Problem 2

Hour	Change in Volume (yd ³ /ft)	Contour Change (ft)			
		0	+5	+10	+15
2	-0.01	-0.18	-0.18	0.00	0.00
4	-0.41	-1.94	-1.94	0.00	0.00
6	-0.89	-4.14	-4.14	0.00	0.00
8	-1.51	-5.90	-5.90	-0.10	-0.10
10	-2.13	-7.24	-6.82	-0.28	-0.28
12	-2.85	-7.92	-7.88	-0.49	-0.49
14	-3.59	-8.98	-8.98	-0.71	-0.71
16	-4.34	-10.09	-10.09	-0.94	-0.94
18	-4.98	-11.40	-11.03	-1.13	-1.13
20	-5.69	-12.14	-12.07	-1.34	-1.34

(Example 2 Concluded)

Example 3 - Generic Profile with Tabulated Water Data**Input**

All input is accomplished through screens accessible from the **Activity Menu**.

F2 General Time & Output Specifications Data Entry

<u>Item</u>	<u>Value</u>	<u>Units</u>
Simulation start time:		
Year	1989	
Month	1	
Day	17	
Hour	2.50	
Length of simulation	20.00	hr
Specific output times from beginning of the simulation (Tabulated)	1, 2, 4, 6, 8, 10, 12, 14, 16, 18, 20	hr

F3 Beach Characteristics Data Entry

<u>Item</u>	<u>Value</u>	<u>Units</u>
Elevation at top of dune	14.100	ft
Elevation at base of dune	6.000	ft
Elevation at top of berm	6.000	ft
Dune width from baseline	50.000	ft
Berm width	100.000	ft
Mean grain size	0.220	mm
Profile	GENERIC	

Generic Profile Data

<u>Item</u>	<u>Value</u>	<u>Units</u>
Cotangent of dune face slope	2.000	
Cotangent of beach face slope	10.000	
Cotangent of nearshore slope	20.000	

F4) Water Level Data Entry**F1) Tabulated Tide Data**

<u>Item</u>	<u>Value</u>	<u>Units</u>
Δt for hydrograph input	4.000	hr
Water level units		ft
Water levels _m ($m = 1 \dots M, M \leq 100$)	0, 3, 5, 7, 5, 2	

F5) Wave Parameter Data Entry

<u>Item</u>	<u>Value</u>	<u>Units</u>
Δt for wave parameters	5.00	hr
Wave height units		ft
Water depth	60.00	ft
Wave heights	8, 5, 3, 12	ft
Wave periods	8, 5, 4, 10	sec
Wave crest angles	10, 45, 30, 0	deg

Output

Results from this application are written to two plot output files. In addition, this application generates one plot.

Plot Output File 1

This file contains simulated profile data representing the original profile and evolving, time-dependent profiles. Each point along the profile is defined by some distance seaward of a baseline and a corresponding elevation. Profiles are reported at the *Tabular Output Time Interval*. Table 6-2-5 is a partial listing of plot output file 1 (default name **PLOTDAT1.OUT**). Figure 6-2-5 is a plot comparing the original profile with the 20-hr profile.

Table 6-2-5
Listing of Plot Output File 1 for Example Problem 3
Original Profile Data

Dist. Seaward from Baseline (ft)	Elev.(ft)
0.	20.00
4.	20.00
8.	20.00
12.	20.00
↓	↓
208.	2.80
212.	2.40
216.	2.00
220.	1.60
224.	1.20
228.	0.80
232.	0.40
↓	↓
1128.	-44.60
1132.	-44.80
1136.	-45.00

Profile Data at 1 hr

Dist. Seaward from Baseline (ft)	Elev.(ft)
0.	20.00
4.	20.00
8.	20.00
12.	20.00
↓	↓
208.	2.82
212.	2.42
216.	2.02
220.	1.62
224.	1.22
228.	0.82
232.	0.42
↓	↓
1128.	-44.60
1132.	-44.80
1136.	-45.00

(Table 6-2-5 Continued on the Next Page)

(Table 6-2-5 Concluded)

Profile Data at 20 hr

Dist. Seaward from Baseline (ft)	Elev.(ft)
0.	20.00
4.	20.00
8.	20.00
↓	↓
200.	1.77
204.	1.58
208.	1.39
212.	1.19
216.	1.00
220.	0.80
224.	0.60
228.	0.40
232.	0.20
236.	0.00
240.	-0.21
↓	↓
1128.	-44.60
1132.	-44.80
1136.	-45.00

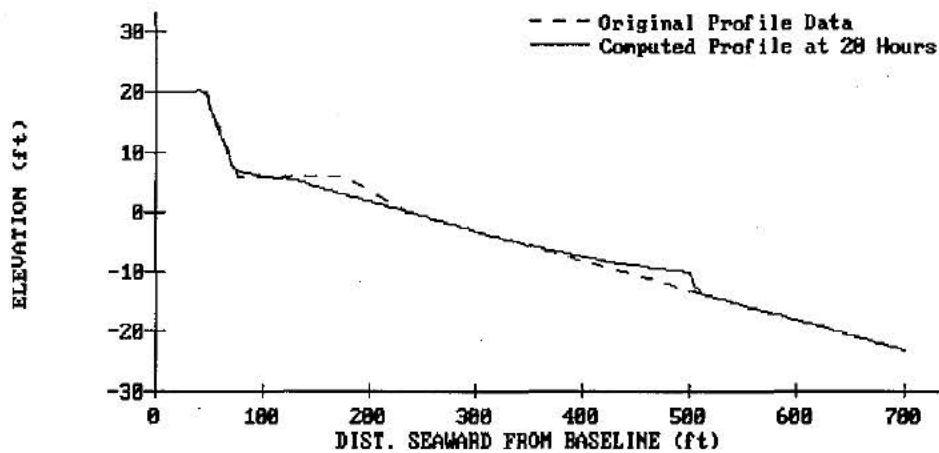

Figure 6-2-5. Profile Change After 20 Hr

Plot Output File 2

This file contains a table consisting of changes in sand volume and changes (advance/retreat) in position of the 0-, +5-, +10-, and +15-ft contours. Erosion statistics are reported at the *Tabular Output Time Interval*. Table 6-2-6 is a listing of plot output file 2 (default name **PLOTDAT2.OUT**).

Table 6-2-6
Listing of Plot Output File 2 for Example Problem 3

Hour	Change in Volume (yd ³ /ft)	Contour Change (ft)			
		0	+5	+10	+15
1	0.08	0.23	0.22	0.00	0.00
2	-0.01	-0.18	-0.18	0.00	0.00
4	-0.41	-1.94	-1.94	0.00	0.00
6	-1.98	-1.17	-10.14	0.00	0.00
8	-2.87	1.45	-11.07	-0.29	-0.29
10	-3.54	23.19	-13.00	-0.82	-0.82
12	-3.95	34.73	-14.31	-1.28	-1.28
14	-6.15	34.73	-46.76	-1.95	-1.95
16	-5.56	34.73	-52.90	-1.64	-1.64
18	-5.78	8.86	-48.78	-1.42	-1.42
20	-7.41	-0.07	-48.45	-1.40	-1.40

(Example 3 Concluded)

Example 4 - Actual Profile Data with No Water Level Data

Input

All input is accomplished through screens accessible from the **Activity Menu**.

F2 General Time & Output Specifications Data Entry

<u>Item</u>	<u>Value</u>	<u>Units</u>
Simulation start time:		
Year	1989	
Month	1	
Day	17	
Hour	3.00	
Length of simulation	20.00	hr
Tabular output time (Interval)	2.00	hr

F3 Beach Characteristics Data Entry

<u>Item</u>	<u>Value</u>	<u>Units</u>
Elevation at top of dune	14.100	ft
Elevation at base of dune	6.000	ft
Elevation at top of berm	6.000	ft
Dune width from baseline	50.000	ft
Berm width	100.000	ft
Mean grain size	0.220	mm
Profile	ACTUAL	

Actual Profile Data

	Distance Seaward from Baseline	Elevation		Distance Seaward from Baseline	Elevation
Pt	X	Y	Pt	X	Y
1	0.000	14.100	28	772.900	-9.000
2	4.000	13.400	29	821.800	-7.600
3	11.200	13.100	30	883.900	-7.500
4	25.100	10.600	31	957.000	-10.000
5	45.000	15.000	32	975.600	-11.300
6	54.400	14.100	33	998.000	-12.000
7	75.700	12.500	34	1028.000	-13.400
8	105.200	12.900	35	1076.000	-16.100
9	139.600	13.500	36	1120.000	-18.100
10	163.900	12.500	37	1153.000	-19.200
11	189.400	10.500	38	1190.000	-20.500
12	205.500	8.600	39	1226.000	-21.500
13	242.500	4.300	40	1285.000	-22.900
14	281.600	2.300	41	1316.000	-23.000
15	320.600	1.100	42	1372.000	-24.400
16	374.700	0.400	43	1421.000	-25.500
17	393.700	0.200	44	1485.000	-26.500
18	421.300	-0.500	45	1532.000	-27.200
19	453.600	-3.100	46	1585.000	-28.300
20	497.300	-6.900	47	1625.000	-29.200
21	539.200	-7.000	48	1682.000	-30.100
22	577.400	-6.600	49	1723.000	-30.400
23	626.700	-7.600	50	1777.000	-31.100
24	638.700	-8.700	51	1821.000	-31.500
25	672.600	-9.800	52	1870.000	-32.200
26	721.900	-9.700	53	1916.000	-32.400
27	735.700	-8.800			

F5 Wave Parameter Data Entry

<u>Item</u>	<u>Value</u>	<u>Units</u>
Δt for wave parameters	20.00	hr
Wave height units		ft
Water depth	60.00	ft
Wave height	8.00	ft
Wave period	8.00	sec
Wave crest angle	10.00	deg

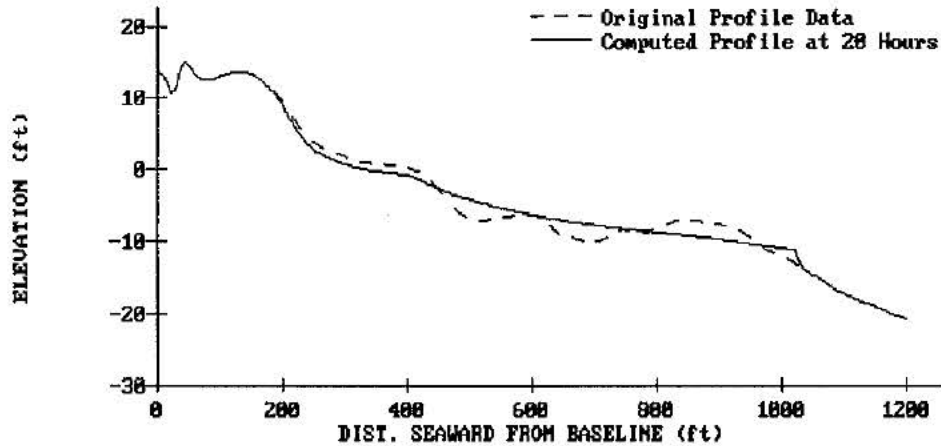

Figure 6-2-6. Profile Change After 20 Hr

Plot Output File 2

This file contains a table consisting of changes in sand volume and changes (advance/retreat) in position of the 0-, +5-, +10-, and +15-ft contours. Erosion statistics are reported at the *Tabular Output Time Interval*. Table 6-2-8 is a listing of plot output file 2 (default name **PLOTDAT2.OUT**).

Table 6-2-8
Listing of Plot Output File 2 for Example Problem 4

Hour	Change in Volume (yd ³ /ft)	Contour Change (ft)			
		0	+5	+10	+15
2	-1.68	-17.54	-2.41	0.00	0.00
4	-2.76	-34.67	-3.98	0.00	0.00
6	-3.50	-48.52	-5.09	0.00	0.00
8	-4.07	-58.17	-5.96	-0.18	0.00
10	-4.54	-64.89	-6.69	-0.84	0.00
12	-4.94	-69.85	-7.29	-1.39	0.00
14	-5.28	-73.61	-7.79	-1.86	0.00
16	-5.59	-76.76	-8.25	-2.33	0.00
18	-5.85	-79.29	-8.65	-2.73	0.00
20	-6.07	-81.33	-8.99	-3.09	0.00

(Example 4 Concluded)

REFERENCES AND BIBLIOGRAPHY

- Birkemeier, W. 1984. "A User's Guide to ISRP: The Interactive Survey Reduction Program," Instruction Report CERC-84-1, US Army Engineer Waterways Experiment Station, Vicksburg, MS.
- Bruun, P. 1954. "Coast Erosion and the Development of Beach Profiles," Technical Memorandum No. 44, Beach Erosion Board, US Army Engineer Waterways Experiment Station, Vicksburg, MS.
- Dean, R. G. 1977. "Equilibrium Beach Profiles: U.S. Atlantic and Gulf Coasts," Ocean Engineering Report No. 12, Department of Civil Engineering, University of Delaware, Newark, DE.
- Kraus, N. C., and Larson, M. 1988. "Beach Profile Change Measured in the Tank for Large Waves, 1956-1957 and 1962," Technical Report CERC-88-6, US Army Engineer Waterways Experiment Station, Vicksburg, MS.
- Kriebel, D. L. 1982. "Beach and Dune Response to Hurricanes," M. S. Thesis, Department of Civil Engineering, University of Delaware, Newark, NJ.
- Kriebel, D. L. 1984a. "Beach Erosion Model (EBEACH) Users Manual, Volume I: Description of Computer Model," Beach and Shores Technical and Design Memorandum No. 84-5-I, Division of Beaches and Shores, Florida Department of Natural Resources, Tallahassee, FL.
- Kriebel, D. L. 1984b. "Beach Erosion Model (EBEACH) Users Manual, Volume II: Theory and Background," Beach and Shores Technical and Design Memorandum No. 84-5-II, Division of Beaches and Shores, Florida Department of Natural Resources, Tallahassee, FL.
- Kriebel, D. L. 1986. "Verification Study of a Dune Erosion Model," *Shore and Beach*, Vol. 54, No. 3, pp. 13-21.
- Moore, B. 1982. "Beach Profile Evolution in Response to Changes in Water Level and Wave Height," M.S. Thesis, Department of Civil Engineering, University of Delaware, Newark, DE.
- Saville, T. 1957. "Scale Effects in Two-Dimensional Beach Studies," *Transactions 7th Meeting of International Association of Hydraulic Research, Lisbon, Portugal*, Vol. 10, pp. A3-1 through A3-10.

CALCULATION OF COMPOSITE GRAIN-SIZE DISTRIBUTIONS

TABLE OF CONTENTS

Description	6-3-1
Input	6-3-1
Output	6-3-1
Plot Output File 1	6-3-1
Plot Output File 2	6-3-2
Trace Output File	6-3-2
Procedure	6-3-2
Select Unit of Measurement for Composite Particle Diameter	6-3-3
Application's Major Activities	6-3-3
Compute and View a Composite	6-3-3
Data Entry Options Menu	6-3-3
Activity Menu	6-3-4
Begin Computations	6-3-5
Enter Header Information for Composite	6-3-5
Enter/Edit Sample Data	6-3-5
Enter Sample Data	6-3-6
Enter Sample Header Data	6-3-6
Enter Sample Sand-Size Distribution	6-3-8
Edit Sample Data	6-3-9
Tag Sample Names for Editing	6-3-9
Edit Sample Header Data	6-3-9
Edit Sample Sand-Size Distribution	6-3-11
Identify Samples for Composite	6-3-12
Surface Samples	6-3-13
Profile Line Number(s)	6-3-14
A Range Of Elevations	6-3-15
Both Range of El. & Profile No.	6-3-16
Individual Surface Name(s)	6-3-16
Core Samples	6-3-17
Individual Core Name(s)	6-3-18
A Range of Elevations	6-3-18
Both Range of El. & Core Name	6-3-19
Profile Line Number(s)	6-3-19
Both Range of El. & Profile No.	6-3-20
All Samples	6-3-21
View Output Data	6-3-21
Plot Output Data	6-3-22
Plot Samples/Composites on the Same Screen	6-3-23
Read Data in External File	6-3-23
Tag Names for Plotting	6-3-23
Enter Title(s) for Plots	6-3-24
Plot Selection Menu	6-3-24
Application Limitations and Error Provisions	6-3-25

CALCULATION OF COMPOSITE GRAIN-SIZE DISTRIBUTIONS

Example Problem	6-3-26
Input	6-3-26
Enter/Edit Sample Data	6-3-26
First Sample	6-3-26
Enter Sample Header Data	6-3-26
Enter Sample Sand-Size Distribution	6-3-27
Second Sample	6-3-28
Enter Sample Header Data	6-3-28
Enter Sample Sand-Size Distribution	6-3-28
Identify Samples for Composite	6-3-29
Begin Computations	6-3-29
Output	6-3-30
Screen Output	6-3-30
Plot Output File 1	6-3-31
Plot Output File 2	6-3-32
Screen Plots	6-3-33
References and Bibliography	6-3-34

CALCULATION OF COMPOSITE GRAIN-SIZE DISTRIBUTIONS

DESCRIPTION

The major concern in the design of a sediment sampling plan for beach-fill purposes is determining the composite grain-size characteristics of both the native beach and the potential borrow site. This application calculates a composite grain-size distribution that reflects textural variability of the samples collected at the native beach or the potential borrow area.

INPUT

The input requirements of this application consist of (a) entering and/or editing sand sample weights and germane identification characteristics, (b) selecting samples to be used in calculating the composite grain-size distribution, and (c) selecting multiple samples and/or composites for plotting on one screen. Data input and selection are accomplished through screens and pop-up windows (hereafter called *requestors*). Detailed lists and descriptions of the *requestors* and input parameters are presented in the *Procedure* section of this document.

OUTPUT

Results from composite calculations may be displayed on screens, written to plot output files 1 and 2 (default name **PLOTDAT1.OUT** and **PLOTDAT2.OUT**), and displayed via plots. Detailed descriptions of the screen output and plots are given in the *Procedure* section of this document. The plot output files are described below.

Plot Output File 1

The contents and format of plot output file 1 (default name **PLOTDAT1.OUT**) duplicate that of option **F4: View Output Data** accessible from the *Activity Menu*. Information reported is:

- a. Wentworth and Unified Soils Classification schemes identifying percentage of the composite's sand weight in various categories (gravel, sand, silt, etc.)
- b. Statistics of the composite calculated by Method of Moments and Folk Graphics Measures.

- c. Header information and percentage by sand weight of specific grain sizes in the composite.
- d. When the composite is composed from core samples, the percentage of the total core length that each sample represents is also provided.

Plot Output File 2

Composite data (header information and percent of sand weight distribution are written to plot output file 2 (default name **PLOTDAT2.OUT**). The format of this file duplicates that of sand samples read from an external file or written to the trace output file with one exception. A "C" in line 4 of this file indicates to the application that it is composite data rather than sample data. Data in this file may be used as input to the second major function of this application, *Plot Samples/Composites on the Same Screen*.

Trace Output File

Sand samples selected for composite calculations are written to the trace output file (default name **TRACE.OUT**). The format and contents of this file match exactly the requirements of input files for this application.

PROCEDURE

This application provides only a Single Case Mode. The Multiple Case Mode is not available. The Single Case Mode requires interaction with the application through numerous *requestors*.

- Press **(F1)** on the Main Menu to select Single Case Mode.
- Fill in the highlighted input fields on the General Specifications screen (or leave the default values). Press **(F1)** when all data on this screen are correct.
- Press **(F6)** on the Functional Area Menu to select Littoral Processes.
- Press **(F3)** on the Littoral Processes Menu to select Calculation of Composite Grain-Size Distributions.

Select Unit of Measurement for Composite Particle Diameter

This item refers only to the *final* system of units (phi, millimeter, or American Society for Testing Materials (ASTM) mesh sizes) in which the composite grain-size distribution is displayed and printed. The units allowed for *Particle Diameter* are:

phi, mm, or ASTM mesh sizes

Table A-4 in Appendix A lists sediment particle diameters (in phi units, equivalent millimeters, and ASTM mesh sizes) recognized by this application. After selecting the desired units, press one of the following keys to select the appropriate action:

- F1** Proceed.
- F10** Exit Application.

Application's Major Activities

This application provides two *major* activities:

- F1** Compute and View a Composite.
- F2** Plot Samples/Composites on Same Screen.
- F10** Exit Menu.

F1 Compute and View a Composite

The following sections describe the various activity menus and screen requestors enabling data entry, data selection, composite calculations, viewing a composite, and plotting a composite.

Data Entry Options Menu

This menu provides two options for interactive participation with the application. The first option allows entering new data sets and the second option allows editing of data sets in an external file.

F1 Initial Case Data Entry.

Use this option to enter an initial (new) set of data. These data, referred to as a *case*, will be stored in a temporary file and will be accessible to the program only while processing this *case*. All data in the *case* are *not* automatically written to the Trace Output File. The only data that are written to

the Trace Output File are those identified for calculating the composite grain-size characteristics. Data identification is made via the **Identify Samples for Composite** option.

(Alt) (F1) Edit Existing Case from File: CGS1.IN.

Use this option to access and modify data saved in an external file and to add additional data. Addition of data is accomplished via the **Enter Sample Data** option. Modification of data is made via the **Edit Sample Data** option. Additions and/or modifications are written to a temporary file and are accessible to the program only while processing this case. All new and/or modified samples are *not* automatically written to the Trace Output file. The only data that are written to the Trace Output File are those identified for calculating the composite grain-size characteristics. Data identification is made via the **Identify Samples for Composite** option.

Typically this data file has been saved as a trace output file from a previous execution of this application. The default input file name is **CGS1.IN**, but other file names (including path name) are acceptable. After entering the file name, press **(ENTER)** to accept this file. *For more information on files, see the section of this manual entitled "General Instructions and Information."*

NOTE: The file **CGS1.IN** contains 128 core samples collected in 1984 for the beach nourishment project at Panama City, Florida.

Activity Menu

The Activity Menu is a point from which all options for Single Case data entry, modification, execution, and plotting are accessible. The options are:

- (F1)** Begin Computations.
- (F2)** Enter/Edit Sample Data.
- (F3)** Identify Samples for Composite.
- (F4)** View Output Data.
- (F5)** Plot Output Data.
- (F10)** Exit Menu.

Each option and the required input are described below.

F1 Begin Computations

Use this option only after all sample data have been entered and/or modified and selected for computations. Before executing the composite grain-size calculations, a *requestor* (**Enter Header Information for Composite**) requiring identification and commentary parameters specific to the composite is displayed.

Enter Header Information for Composite

Enter an accurate description of data used in calculating the composite. This information is helpful for immediate as well as future uses of the composite grain-size distribution. The following list describes parameters required on the **Enter Header Information for Composite** *requestor*.

<u>Item</u>	<u>Description</u>
Composite Name	Unique name assigned to this composite
Analyzer	Person/company/agency analyzing the data
Title	Project title
Comment	Any helpful information

When the header information has been entered, press one of the following keys to select the next appropriate action:

- F1** Accept Data & Begin Computations.
 - F10** Exit Window.
-

F2 Enter/Edit Sample Data

This option provides an interactive capability to enter new or edit existing sand sample data that are used for calculating composite grain-size distributions. The set of data that is entered or edited is referred to as the **case**. Input is accomplished through numerous *requestors*. A flowchart showing *requestors* available under the **Enter/Edit Sample Data** option is shown in Figure 6-3-1. The format and data requirements for these *requestors* are described below.

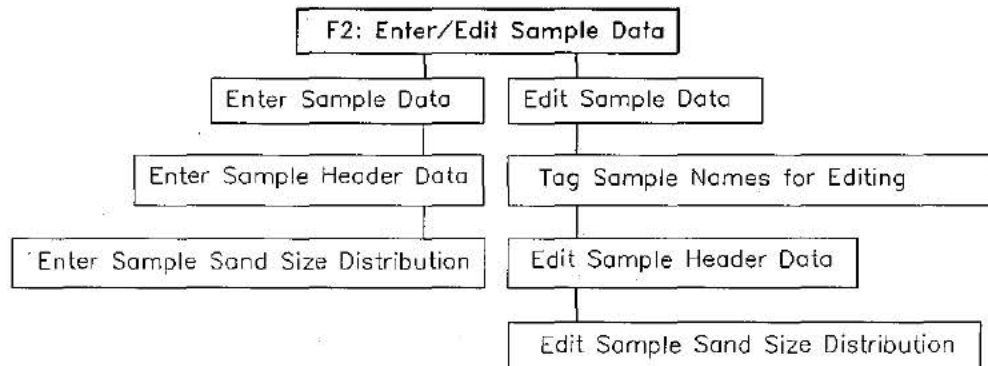

Figure 6-3-1. Flowchart of Requestors for Option **F2**, "Enter/Edit Sample Data"

When the **F2** option (**Enter/Edit Sample Data**) from the **Activity Menu** is selected, the **Enter/Edit Sample Data** requestor is displayed.

Enter/Edit Sample Data

This requestor provides options for:

- Entering new sand sample data (**Enter Sample Data**).
- Editing existing sand sample data (**Edit Sample Data**).

To select an option, move the cursor to the desired choice and press **↵**. Selecting either of these choices will display requestors for further input.

Enter Sample Data

This option allows for interactively adding new sand sample data to an existing case or creating a new case. Two requestors are required to record data. The first requestor (**Enter Sample Header Data**) is used to collect header data and germane information for each sample in the case. The second requestor (**Enter Sample Sand-Size Distribution**) is used to record sand-size distribution data for each sample. A case can contain a maximum of 144 samples. These requestors are described in detail below.

Enter Sample Header Data

This requestor collects header data and general information unique to each sand sample in the case. The following list describes parameters on the **Enter Sample Header Data** requestor with their corresponding units and range of data recognized by this application:

<u>Item</u>	<u>Description</u>
Sample Name	Unique name assigned to this sample (each sample <i>must</i> be uniquely identified)
Title	Project title
Date Collected	Date the sand sample was collected
Analyzer	Person/company/agency analyzing the data
Comment	Any helpful information
Position on Beach	Location where sand sample was taken (nearshore, offshore, etc.)
Type of Sample	Method of collection of sample (surface, core, vibracore, etc.)

<u>Item</u>	<u>Units</u>	<u>Data Range</u>
Profile Number		0 to 9,999
Surface/Core Elevation	ft, m	-100.0 to 100.0
Core Length (Core Sample only)	ft, m	0.0 to 50.0
Top of Sample (Core Sample only)	ft, m	0.0 to 50.0
Bottom of Sample (Core Sample only)	ft, m	0.0 to 50.0
Latitude		0.0 to 9,999,999.
Longitude		0.0 to 9,999,999.
Total Sand Weight	grams	0.0 to 500.0

Particle Diameter Units phi, mm, ASTM mesh size

NOTE: Particle Diameter units declared on the **Enter Sample Header Data** *requestor* identify the units of measurement for grain sizes collected on the **Enter Sample Sand-Size Distribution** *requestor*.

When data have been entered, press one of the following keys to select the next appropriate action:

- ALT F1** Continue Input (invokes the **Enter Sample Sand-Size Distribution** *requestor*).
- F1** Accept Data & Return.
- F10** Return to Menu (Activity Menu).

Enter Sample Sand-Size Distribution

This *requestor* collects sand weight in grams for standard particle diameters (see Table A-4 in Appendix A). The standard particle diameters are displayed as an aid for inputting sand weights. The particle diameter unit (phi, millimeter, or ASTM mesh size) specified on the **Enter Sample Header Data** *requestor* determines the unit of measurement for sand weights recorded on the **Enter Sample Sand-Size Distribution** *requestor*. A maximum of 56 sand weights can be entered. The range of sand weight values allowed by this application is listed below.

<u>Item</u>	<u>Units</u>	<u>Data Range</u>
Sand Weight	grams	-1.0 to 3000.0

NOTE: A sand weight of *-1.0* indicates to the application that **NO** weight was recorded for the associated grain size. This allows sand distributions to be entered independently of the sieve interval. Thus, mixed and/or well-sorted sand populations may be recorded.

LIMITATION: Sediment particle diameters accepted by this application are listed in Table A-4 in Appendix A.

When finished entering sand weights on this *requestor*, press one of the following keys to select the next appropriate action:

(ALT)(F1) Continue Input.

NOTE: A maximum of 28 particle diameters and associated sand weights can be displayed and entered on one screen. To display the remaining 28 standard particle diameters and enter corresponding sand weights, press **(ALT)(F1)**. After all sand weights have been entered, press **(ALT)(F1)** again to invoke the **Enter Sample Header Data** *requestor* for entering data for the next sand sample.

(F1) Accept Data & Return.

(F10) Return to Menu (to Activity Menu).

Edit Sample Data

This option allows for interactively editing sand sample data. Three *requestors* guide the user through the editing procedure. The first *requestor* (**Tag Sample Names for Editing**) provides an easy process to identify samples for editing. The second *requestor* (**Edit Sample Header Data**) is used to edit header data and general information for each sample selected. The *third requestor* (**Edit Sample Sand-Size Distribution**) is used to edit sand-size distribution data for each sample. These *requestors* are described in detail below.

Tag Sample Names for Editing

This *requestor* allows identifying samples for editing by tagging the name of the sample. All sample names in the case are displayed as an aid for identification and tagging. To select and tag a sample, move the cursor to the desired choice and press . Continue this procedure until all desired samples are tagged.

When selection and tagging are complete, press one of the following keys to select the next appropriate action:

ALT **F1** More Input.

NOTE: A maximum of 60 sample names are displayed on one screen. If more than 60 samples are in the case, press **ALT** **F1** to display more sample names.

F1 Accept Data, Exit Window (invokes the **Edit Sample Header Data** *requestor* to begin the editing process).

F10 Exit Window (Activity Menu).

Edit Sample Header Data

This *requestor* allows editing the header data and general information unique to the tagged sand samples. The following list describes the specific parameters on the **Edit Sample Header Data** *requestor* that can be edited, with their corresponding units and range of data recognized by this application:

Edit Sample Sand-Size Distribution

This *requestor* displays sand weights in grams for standard particle diameters for the tagged sand samples. The standard particle diameters are displayed as an aid for inputting sand weights. The particle diameter unit (phi, millimeter, or ASTM mesh size) specified on the **Edit Sample Header Data** *requestor* determines the unit of measurement for sand weights recorded on the **Edit Sample Sand-Size Distribution** *requestor*. A maximum of 56 sand weights can be entered. The range of sand weight values allowed by this application is listed below.

<u>Item</u>	<u>Units</u>	<u>Data Range</u>
Sand Weight	grams	-1.0 to 3,000.0

NOTE: A sand weight of *-1.0* indicates to the application that **NO** weight was recorded for the associated grain size. This allows sand distributions to be entered independently of the sieve interval. Thus, mixed and/or well-sorted sand populations may be recorded.

LIMITATION: Sediment particle diameters accepted by this application are listed in Table A-4 in Appendix A.

When finished editing sand weights on this *requestor*, press one of the following keys to select the next appropriate action:

(ALT)(F1) Continue Input.

NOTE: A maximum of 28 particle diameters and associated sand weights can be displayed and recorded on one screen. To display the remaining standard particle diameters and corresponding sand weights, press **(ALT)(F1)**. After all sand weights have been edited, press **(ALT)(F1)** again to invoke the **Edit Sample Header Data** *requestor*. This will display recorded data for the next tagged sand sample.

(F1) Accept Data & Return.

(F10) Return to Menu (Activity Menu).

F3 Identify Samples for Composite

This option provides an interactive capability to identify and select data samples from the case for use in calculating the composite grain-size distribution. Selection of the data is accomplished through numerous *requestors*. A flowchart depicting *requestors* available via the **F3: Identify Samples for Composite** option is shown in Figure 6-3-2. The samples selected from the case via this option are written to the **Trace Output File** (default name **TRACE.OUT**) and then used in the composite grain-size calculations. The format and data requirements for these *requestors* are described below.

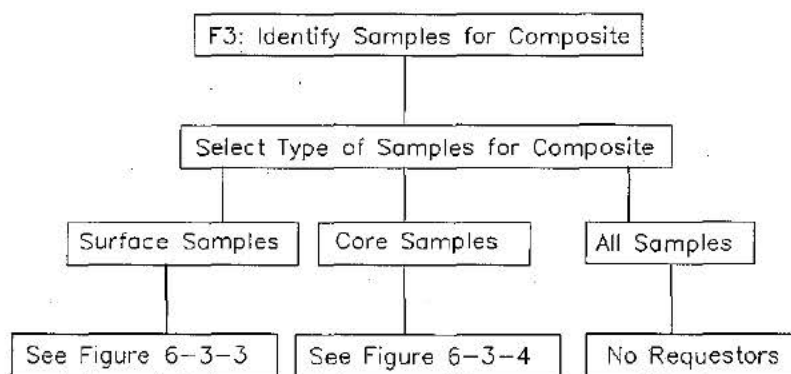

Figure 6-3-2. Flowchart of Requestors for Option **F3**, "Identify Samples for Composite"

When the **F3: Identify Samples for Composite** option is selected, the **Select Type of Samples for Composite** *requestor* is displayed.

Select Type of Samples for Composite

This *requestor* provides three options for identifying the type of samples that will make up the data set used in the composite grain-size calculations. The options are:

- ° Surface Samples.
- ° Core Samples.
- ° All Samples.

To select an option, move the cursor to the desired choice and press **⊗**. Selecting either **Surface Samples** or **Core Samples** will display more *requestors* for further input. Selecting **All Samples** requires no further *requestors*.

Surface Samples

When the **Surface Samples** option is selected, the **Select Surface Samples By** requestor is displayed. This requestor invokes other requestors (Figure 6-3-3) that collect choices and input to determine the data set for composite grain-size calculations.

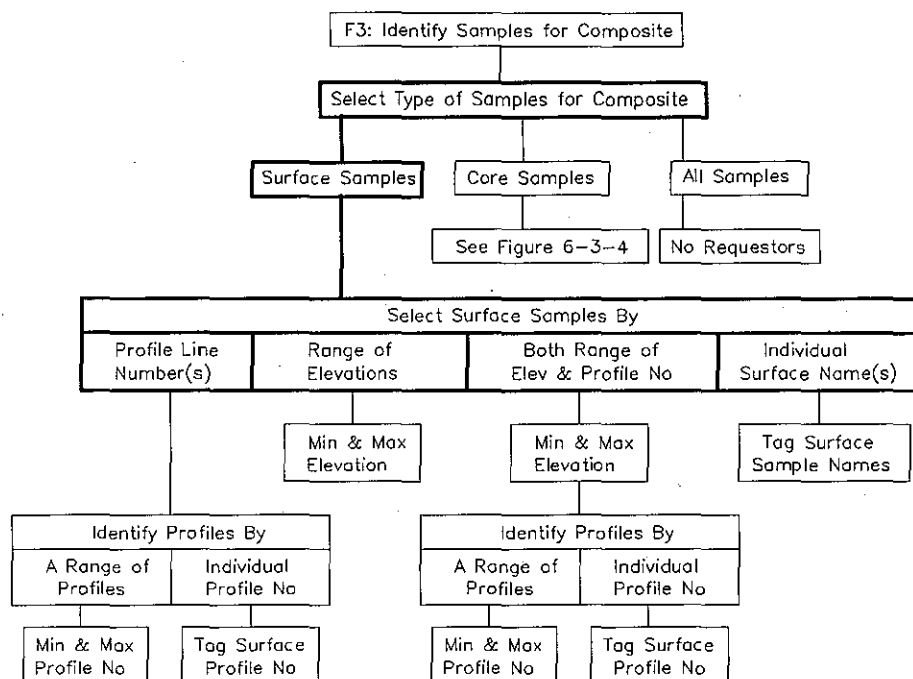

Figure 6-3-3. Flowchart of Requestors for the Surface Samples Option

The **Select Surface Samples By** requestor provides four choices for selecting samples. These choices are:

- Profile Line Number(s)
- A Range of Elevations
- Both Range of El. & Profile No.
- Individual Surface Name(s)

Make a selection by moving the cursor to the desired choice and pressing **↵**. Each choice will display more requestors for identifying desired surface samples. The format and data requirements of resulting requestors are described below. After samples are identified and selected, the program returns to the **Select Surface Samples By** requestor. To accept samples that were selected, press **F1**. The program now writes this data set to the **Trace Output File** (default name **TRACE.OUT**) and these data are used in the composite grain-size calculations.

Profile Line Number(s)

This option allows selecting samples by a specific number assigned to a profile line. Choosing this option invokes the **Identify Profiles By requestor**. The choices offered by this *requestor* are:

- A Range of Profiles.
- Individual Profile(s).

Select one of the two choices by moving the cursor to the desired choice and pressing . Both choices display more *requestors* that ultimately identify a set of surface samples for the composite data set. These *requestors* are described below.

A Range of Profiles

This choice invokes the **Enter Profile Range requestor**, which allows selecting samples that fall within a certain range of profile numbers.

The range of profile number values allowed by this application is given below:

<u>Item</u>	<u>Data Range</u>
Minimum Profile Number	0 to 9999
Maximum Profile Number	0 to 9999

When the range of profile numbers has been entered, press one of the following keys to select the next appropriate action:

Accept Data & Exit Window.

Exit Window.

Individual Profile(s)

This choice invokes the **Tag Surface Sample Profile Numbers for Composite requestor**, which allows selecting samples by tagging the desired profile line number(s). All sample profile line numbers in the case are displayed as an aid to identification and tagging. To select and tag a sample, move the cursor to the desired choice and press . Continue this procedure until all desired samples are tagged.

When selection and tagging are complete, press one of the following keys to select the next appropriate action:

ALT **F1** More Input.

NOTE: A maximum of 60 sample names are displayed on one screen. If more than 60 samples are in the case, press **ALT** **F1** to display more sample names.

F1 Accept Data, Exit Window.

F10 Exit Window.

A Range Of Elevations

This option allows selecting only those samples that fall within a certain range of elevations. Choosing this option invokes the **Enter Elevation Range requestor**.

The units and range of elevation values allowed by this application are given below:

<u>Item</u>	<u>Units</u>	<u>Data Range</u>
Minimum Elevation	ft, m	-100.0 to 100.0
Maximum Elevation	ft, m	-100.0 to 100.0

When the range of elevations has been entered, press one of the following keys to select the next appropriate action:

F1 Accept Data & Exit Window.

ALT **F10** Exit Window.

Both Range of El. & Profile No.

This option allows selecting samples that fall within a certain range of elevations and for specific profile number(s). A sample must meet **both** elevation and profile number criteria to be selected for the data set. Selection of samples is made through numerous *requestors*. The first *requestor* that appears is the **Enter Elevation Range** *requestor* that was described earlier. After the maximum and minimum elevations have been entered, the **Identify Profiles By** *requestor* is invoked by responding *yes* to the question *To Profile Screens?* Selection of samples can then continue through two more *requestors*.

- See **A Range of Profiles** (described earlier).
- See **Individual Profile(s)** (described earlier).

Individual Surface Name(s)

This option invokes the **Tag Surface Samples Names for Composite** *requestor*, which allows selecting samples by tagging the desired surface sample name(s). All sample names in the **case** are displayed as an aid for identification and tagging. To select and tag a surface sample, move the cursor to the desired name and press . Continue this procedure until all desired samples are tagged.

When selection and tagging are complete, press one of the following keys to select the next appropriate action:

ALT **F1** More Input.

NOTE: A maximum of 60 sample names are displayed on one screen. If more than 60 samples are in the **case**, press **ALT** **F1** to display more sample names.

F1 Accept Data, Exit Window.

F10 Exit Window.

Core Samples

When the **Core Samples** option is selected, the **Select Core Samples By** *requestor* is displayed. This *requestor* invokes other *requestors* (Figure 6-3-4) that collect choices and input to determine the data set for composite grain-size calculations.

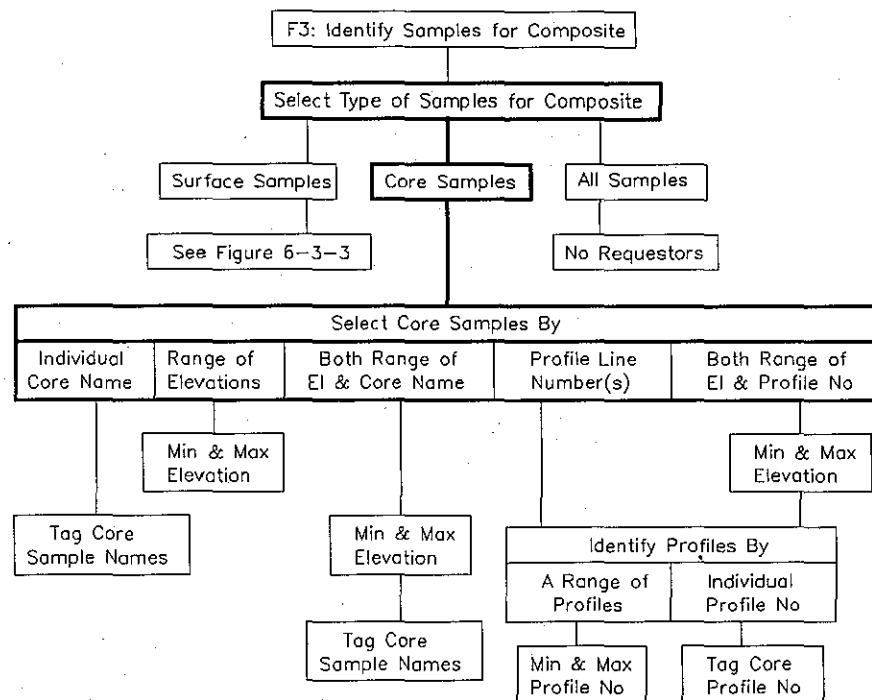

Figure 6-3-4. Flowchart of Requestors for the Core Samples Option

The **Select Core Samples By** *requestor* provides five choices for selecting samples. These choices are:

- Individual Core Name(s)
- A Range of Elevations
- Both Range of El. & Core Name
- Profile Line Number(s)
- Both Range of El. & Profile No.

Make a selection by moving the cursor to the desired choice and pressing **⊞**. Each choice displays more *requestors* for identifying desired core samples. The format and data requirements of resulting *requestors* are described below. After samples are identified and selected, the program returns to the **Select Core Samples By** *requestor*. To accept samples that were selected, press **F1**. The program now writes this data set to the **Trace Output File** (default name **TRACE.OUT**) and these data are used in the composite grain-size calculations.

Individual Core Name(s)

This option invokes the **Tag Core Samples Names for Composite** *requestor*, which allows selecting samples by tagging the desired core name(s). All sample names in the **case** are displayed as an aid for identification and tagging. To select and tag a core sample, move the cursor to the desired name and press **⊗**. Continue this procedure until all desired samples are tagged.

When selection and tagging are complete, press one of the following keys to select the next appropriate action:

ALT F1 More Input.

NOTE: A maximum of 60 sample names are displayed on one screen. If more than 60 samples are in the **case**, press **ALT F1** to display more sample names.

F1 Accept Data, Exit Window.

F10 Exit Window.

A Range of Elevations

This option allows selecting only those samples that fall within a certain range of elevations. Choosing this option invokes the **Enter Elevation Range** *requestor*.

The units and range of elevation values allowed by this application are given below:

<u>Item</u>	<u>Units</u>	<u>Data Range</u>
Minimum Elevation	ft, m	-100.0 to 100.0
Maximum Elevation	ft, m	-100.0 to 100.0

When the range of elevations has been entered, press one of the following keys to select the next appropriate action:

F1 Accept Data & Exit Window.

ALT F10 Exit Window.

Both Range of El. & Core Name

This option allows selecting samples that fall within a range of elevations and for specific core name(s). A sample must meet **both** elevation and name criteria to be selected for the data set. Selection of samples is made through two *requestors*.

- Enter Elevation Range.
- Tag Core Samples for Composite.

The first *requestor* displayed is the **Enter Elevation Range** *requestor*, which was described earlier in the section titled **A Range of Elevations**. After maximum and minimum elevations have been entered, the **Tag Core Sample Names for Composite** *requestor* (described earlier in the section titled **Individual Core Name(s)**) is invoked by responding *yes* to the question *To Core Name Screens?*

Profile Line Number(s)

This option allows selecting samples by a specific number assigned to a profile line. Choosing this option invokes the **Identify Profiles By** *requestor*. The choices offered by this *requestor* are:

- A Range of Profiles.
- Individual Profile(s).

Select one of the two choices by moving the cursor to the desired choice and pressing . Both choices display more *requestors* that ultimately identify a set of core samples for the composite data set. These *requestors* are described below.

A Range of Profiles

This choice invokes the **Enter Profile Range** *requestor* which allows selecting samples that fall within certain profile numbers.

The range of profile number values allowed by this application is given below:

<u>Item</u>	<u>Data Range</u>
Minimum Profile Number	0 to 9999
Maximum Profile Number	0 to 9999

When the range of profile numbers has been entered, press one of the following keys to select the next appropriate action:

- F1** Accept Data & Exit Window.
- ALT F10** Exit Window.

Individual Profile(s)

This choice invokes the **Tag Core Sample Profile Numbers for Composite requestor**, which allows selecting samples by tagging the desired profile line number(s). All sample profile line numbers in the **case** are displayed as an aid to identification and tagging. To select and tag a sample, move the cursor to the desired choice and press **⊗**. Continue this procedure until all desired samples are tagged.

When selection and tagging are complete, press one of the following keys to select the next appropriate action:

ALT F1 More Input.

NOTE: A maximum of 60 sample names are displayed on one screen. If more than 60 samples are in the **case**, press **ALT F1** to display more sample names.

F1 Accept Data, Exit Window.

F10 Exit Window.

Both Range of El. & Profile No.

This option allows selecting samples that fall within certain elevations **and** for specific profile number(s). A sample must meet **both** elevation and profile number criteria to be selected for the data set. Selection of samples is made through numerous *requestors*. The first *requestor* that appears is the **Enter Elevation Range requestor** described earlier. After the maximum and minimum elevations have been entered, the **Identify Profiles By requestor** is invoked by responding *yes* to the question *To Profile Screens?* Selection of samples can then continue through two more *requestors*.

- See **A Range of Profiles** (described earlier).
 - See **Individual Profile(s)** (described earlier).
-

All Samples

Selecting **All Samples** requires no further *requestors*, and all samples in the case make up the data set used for the composite grain-size calculations. The program then writes this data set to the **Trace Output file** (default name **TRACE.OUT**). This same data set is used to determine properties of the composite when the application is executed.

SUGGESTION:

After an initial or new set of sample data has been entered, it is suggested that the **All Samples** choice be selected to save *all* the data that were entered. This file can then be recalled, and desired samples from it can be selected for the composite calculations.

F4 View Output Data

This option allows for viewing the results of this application, which are displayed on two screens.

- The first screen displays percentage by weight (for the composite) of the various sediment categories on the Wentworth and Unified Soils classification schemes. This screen also displays the following statistics of the composite sample calculated by Method of Moments and Folk Graphics Measures.
 - Median Diameter.
 - Mean Diameter.
 - Standard Deviation.
 - Skewness.
 - Kurtosis.
 - The second screen displays parameters for the composite.
 - Header information.
 - Percent weight distribution.
-

(F5) Plot Output Data

This application generates three plots. The plots may be accessed from the **Composite Grain-Size Distribution Plot Selection Menu** which is displayed when the **Plot Output Data (F5)** option is requested. To access a plot, move the cursor (using the arrow keys) to the desired plot and press **(F1)**. (Appendix C describes options to customize plots.) Available plots are:

- Frequency Weight Percent.
- Cumulative Weight Percent.
- Probability Weight Percent.
- ALL PLOTS.

NOTE: This option will make all the plots available for viewing. Use the **NEXT** option of the graphics package (Appendix C) to view each plot successively.

- EXIT MENU.
-

F2 Plot Samples/Composites on the Same Screen

This option from the *Application's Major Activities* menu is used to plot individual samples, composites, or a combination of individual samples and composites. As many as five may be plotted on a screen. The following sections describe various screen *requestors* enabling data entry, selection, and plotting.

Read Data in External File

Use this option to read sample and/or composite data saved in an external file. Normally the data file is created with a text editor, or saved as a trace file (default name **TRACE.OUT**) or as plot output file 2 (default name **PLOTDAT2.OUT**) from a previous execution of this application. The format and contents of a trace file and a plot output file 2 produced by this application match exactly the requirements of this input file. The default input file name is **CGSPLT.IN** but other file names (including path name) are acceptable. After entering the file name, press **ENTER** to accept this file. *For more information on files, see the section of this manual entitled "General Instructions and Information."*

Press one of the following keys to select the next appropriate action:

- ALT F10** Accept Data & Exit (after reading the data file, invoke **Tag Names for Plotting requestor**).
- F1** Exit Window.

Tag Names for Plotting

This *requestor* allows identifying sample and/or composites for plotting by tagging the name. All names in the file are displayed as an aid for identification and tagging. To select and tag a name, move the cursor to the desired choice and press **X**. Continue this procedure until all desired names (maximum of five) are tagged. (Allowing more than five on a plot may produce a cluttered display.)

When selection and tagging are complete, press one of the following keys to select the next appropriate action:

- ALT F1** More Input.
NOTE: A maximum of 60 composite and/or sample names are displayed on one screen. If more than 60 names are in the file, press **ALT F1** to display more names.
- F1** Accept Data, Exit Window (invokes the **Enter Title for Plots requestor**).
- F10** Exit Window.

Enter Title(s) for Plots

The following list describes parameters on the **Enter Title(s) for Plot** requestor:

<u>Item</u>	<u>Description</u>
Title 1	Text displayed on the first title line of the plot (a maximum of 60 characters).
Title 2	Text displayed on the second title line of the plot (a maximum of 60 characters).

When text for the title(s) has been entered, press one of the following keys to select the next appropriate action:

- F1** Accept Data & Begin Plotting (invokes the **Plot Selection Menu** requestor).
- ALT F10** Exit Window.

Plot Selection Menu

This option provides a visual comparison of the selected data. Three plotting options are available:

- Frequency Weight Percent.
- Cumulative Weight Percent.
- Probability Weight Percent.
- ALL PLOTS.

NOTE: This option will make all the plots available for viewing. Use the **NEXT** option of the graphics package (Appendix C) to view each plot successively.

- EXIT MENU.

To access a plot, move the cursor (using the arrow keys) to the desired plot and press **F1**. (Appendix C describes options to customize plots.)

Application Limitations and Error Provisions

Provisions are available for correcting input data errors detected by the program. If an error in a sample is encountered, a message is displayed at the bottom of the screen. This message, while terse, is usually enough to identify which sample and field are causing the error. Errors must be corrected before a sample is selected for computing or plotting. Use the **Edit Sample Data** option to make corrections.

A limitation of this application is that it accepts only specific particle diameters in phi units, millimeters, or ASTM mesh sizes. These particle diameters are listed in Table A-4 of Appendix A.

EXAMPLE PROBLEM

This example will demonstrate how to interactively enter an initial/new case of sand sample data, save it in the Trace Output File, execute the computations, and describe output options.

Input

The input for this example consists of entering germane identification characteristics and sand weights for sand samples collected from a core taken in Panama City, Florida. Since this is an initial/new data case, it is suggested that the data be saved in a file. Therefore, it is required that the default name (TRACE.OUT) for the Trace Output File be renamed at the time the **General Data Specifications** screen is displayed. (This is the second screen displayed when the ACES Program is started.) Rename the Trace Output File to **CGSEX.IN**. Now proceed to the **Calculation of Composite Grain-Size Distributions** application.

F2 Enter/Edit Sample Data

This example consists of entering data for two samples collected from a core boring taken in Panama City, Florida, in 1984.

First Sample

Enter Sample Header Data

<u>Item</u>	<u>Value</u>
Sample Name	2-84 1
Title	Panama City Beach Nourishment
Date Collected	1984
Analyzer	CEWES-GL
Comment	1st of 2 samples from boring
Profile Number	0
Surface/Core Elevation	-38.
Surface/Core Elevation Units	Feet
Core Length	19.4

Core Length Units	Feet
Top of Sample	0.0
Top of Sample Units	Feet
Bottom of Sample	18.1
Bottom of Sample Units	Feet
Latitude	1606792 (state plane coordinate system)
Longitude	406465 (state plane coordinate system)
Position on Beach	Offshore
Type of Sample	Vibracore
Total Sand Weight	72.519 grams
Particle Diameter Units	PHI

Enter Sample Sand-Size Distribution

Particle Diameter (phi)	Sand Weight (grams)
0.75	0.000
1.00	2.498
1.25	0.606
1.50	0.984
1.75	2.195
2.00	3.179
2.25	7.721
2.50	11.431
2.75	16.805
3.00	17.184
3.25	5.677
3.50	3.028
3.75	0.984
4.00	0.227

Second Sample

Enter Sample Header Data

<u>Item</u>	<u>Value</u>
Sample Name	2-84 2
Title	Panama City Beach Nourishment
Date Collected	1984
Analyzer	CEWES-GL
Comment	2nd of 2 samples from boring
Profile Number	0
Surface/Core Elevation	-38.
Surface/Core Elevation Units	Feet
Core Length	19.4
Core Length Units	Feet
Top of Sample	18.1
Top of Sample Units	Feet
Bottom of Sample	19.4
Bottom of Sample Units	Feet
Latitude	1606792 (state plane coordinate system)
Longitude	406465 (state plane coordinate system)
Position on Beach	Offshore
Type of Sample	Vibracore
Total Sand Weight	37.706 grams
Particle Diameter Units	PHI

Enter Sample Sand-Size Distribution

Particle Diameter (phi)	Sand Weight (grams)
0.75	0.000
1.00	5.112
1.25	1.595
1.50	2.908
1.75	5.065
2.00	5.090
2.25	6.425
2.50	3.283
2.75	3.517
3.00	2.204
3.25	0.985
3.50	0.281
3.75	0.328
4.00	0.094

F3 Identify Samples for Composite

After the sample data have been entered, they need to be saved in a file that can be edited and used later. The procedure is outlined below:

1. At the main activity menu, press **F3**.
 2. Move cursor to **Core Sample** and press **⊗**.
 3. Move cursor to **Individual Core Name(s)** and press **⊗**.
 4. Move cursor to each name and press **⊗**.
 5. Press **F1** (Accept Data & Exit Window).
 6. Press **F1** (Accept Data & Exit).
-

F1 Begin Computations

The data have now been identified and tagged, and computations can begin.

1. Press **F1** at the main activity menu to enter header information for the composite.
2. Enter header information for composite.

<u>Item</u>	<u>Value</u>
Composite Name	Panama, FL
Analyzer	CEWES-CERC
Title	Example for ACES User's Guide
Comment	This is a Composite of Data from the File CGSEX.IN

3. Press **F1** (Accept Data & Begin Computations).

The file **CGSEX.IN** is now created and saved and computations are started.

Output

Results from this application are displayed on two screens, written to plot output files 1 and 2 (default names **PLOTDAT1.OUT** and **PLOTDAT2.OUT**), and displayed on three plots.

Screen Output

From the Activity Menu, press **F4** (**View Output Data**) to display the output. The first screen (Figure 6-3-5) displays percentage by weight (for the composite) of the various sediment categories on the Wentworth and Unified Soils classification schemes. This screen also displays statistics of the composite sample calculated by Method of Moments and Folk Graphics Measures. The second screen (Figure 6-3-6) displays header information and percentage by weight of specific grain sizes for the composite.

Method	Gravel				Silt	Clay
		Coarse	Medium	Fine		
Wentworth	0.00	4.12	11.71	84.17	0.00	0.00
Unified	0.00	0.00	5.19	94.51	0.31	0.00

Standard Statistics	Method of Moments	Folk Graphic Measures	Grain Size
Median Diameter		2.59 phi	0.166 mm
Mean Diameter	2.49 phi	2.52 phi	0.179 mm
Standard Deviation	0.58 phi	0.56 phi	
Skewness	-0.90	-0.27	
Kurtosis	3.98	1.29	

Figure 6-3-5. First Screen Output for Example Problem

Composite of Grain-Size Distributions											
Composite		Title						Date Analyzed			
Panama, FL		Example for ACES User's Guide						07/02/92			
Analyzer		Comment						Total Weight			
CEWES-CERC		This is a composite of Data from File CGSEX.IN						100.00			
Type of Samples		Samples in Composite		Top of Composite		Bottom of Composite					
Offshore		2		0.00 feet		0.00 feet					
ASTM	MM	PHI	Weight	ASTM	MM	PHI	Weight	ASTM	MM	PHI	Weight
MESH	Size	Size	(%)	MESH	Size	Size	(%)	MESH	Size	Size	(%)
30.00	0.59	0.75	0.000	35.00	0.50	1.00	4.122	40.00	0.42	1.25	1.063
45.00	0.35	1.50	1.783	50.00	0.30	1.75	3.724	60.00	0.25	2.00	5.140
70.00	0.21	2.25	11.075	80.00	0.177	2.50	15.290	100.00	0.149	2.75	22.245
120.00	0.125	3.00	22.500	140.00	0.105	3.25	7.479	170.00	0.088	3.5	3.946
200.00	0.074	3.75	1.324	230.00	.0625	4.00	0.309				

Figure 6-3-6. Second Screen Output for Example Problem

Plot Output File 1

This file (default name **PLOTDAT1.OUT**) contains the following composite information:

- Wentworth and Unified Soils Classification schemes identifying percentage of the composite's sand weight in various categories (gravel, sand, silt, etc.)
- Statistics of the composite calculated by Method of Moments and Folk Graphics Measures.
- Header information and percentage by sand weight of specific grain sizes in the composite.
- When the composite is composed of core samples, the percentage of the total core length that each sample represents is also provided.

Table 6-3-1 is a listing of plot output file 1 for this example.

Table 6-3-1
Listing of Plot Output File 1 for Example Problem

Calculation of Composite Grain-Size Distribution

Sample: 2-84 1 represents 93.3% of the core

Sample: 2-84 2 represents 6.7% of the core

Calculation of Composite Grain-Size Distribution

SIZE CLASSIFICATION: (By Percent Weight)	Gravel	----- Coarse	Sand Medium	----- Fine	Silt	Clay
Wentworth	0.00	4.12	11.71	84.17	0.00	0.00
Unified	0.00	0.00	5.19	94.51	0.31	0.00

STANDARD STATISTICS: Method of Moments Folk Graphic Measures Grain Size

Median Diameter		2.59 phi	0.166mm
Mean Diameter	2.49 phi	2.52 phi	0.179mm
Standard Deviation	0.58 phi	0.56 phi	
Skewness	-0.90	-0.27	
Kurtosis	3.98	1.29	

Composite	Title										Date Analyzed	
Panama, FL	Example for ACES User's Guide										07/02/92	
Analyzer	Comment										Total Weight	
CEWES-CERC	This is a composite of Data from File CGSEX.IN										100.00	
Type of Samples	Samples in Composite			Top of Composite				Bottom of Composite				
Offshore	2			0.00 feet				0.00 feet				
ASTM	MM	PHI	Weight	ASTM	MM	PHI	Weight	ASTM	MM	PHI	Weight	
MESH	Size	Size	(%)	MESH	Size	Size	(%)	MESH	Size	Size	(%)	
30.00	0.59	0.757	0.000	60.00	0.25	2.00	5.140	140.0	0.105	3.25	7.479	
35.00	0.50	1.00	4.122	70.00	0.21	2.25	11.075	170.0	0.088	3.50	3.946	
40.00	0.42	1.25	1.063	80.00	0.177	2.50	15.290	200.0	0.074	3.75	1.324	
45.00	0.35	1.50	1.783	100.0	0.149	2.75	22.245	230.0	.0625	4.00	0.309	
50.00	0.30	1.75	3.724	120.0	0.125	3.00	22.500					

Plot Output File 2

This file (default name **PLOTDAT2.OUT**) contains header information and percent of sand weight distribution for the composite generated by the example problem.

Table 6-3-2 is a listing of plot output file 2 for this example.

Table 6-3-2
Listing of Plot Output File 2 for Example Problem

```

Panama, FL Example for ACES User's Guide                               1984
CEWES-CERC This is a composite of data from file CGSEX.IN
  0.00f   0.00f   0.00f   00.0f  1606792.00   406465.00   07/02/92
Offshore  Vibracore  100.00   14   PHI  C
  0.75   0.000   1.00   4.122   1.25   1.063   1.50   1.783   1.75   3.724
  2.00   5.140   2.25  11.075   2.50  15.290   2.75  22.245   3.00  22.500
  3.25   7.479   3.50   3.946   3.75   1.324   4.00   0.309
    
```

A "C" in line 4 of this file indicates to the application that this is composite data rather than sample data. Otherwise, the format is the same as that of sand samples read from an external file or written to the trace output file. Composite data may be stored in a file containing other composite or sample data to be plotted. See section titled **Plot Samples/Composites on the Same Screen** for more information.

Screen Plots

This application generates three plots. The plots may be accessed from the **Composite Grain-Size Distribution Plot Selection Menu**, which is displayed when the **Plot Output Data** (F5) option is requested. The plots generated by the example problem are shown below (Figures 6-3-7 to 6-3-9).

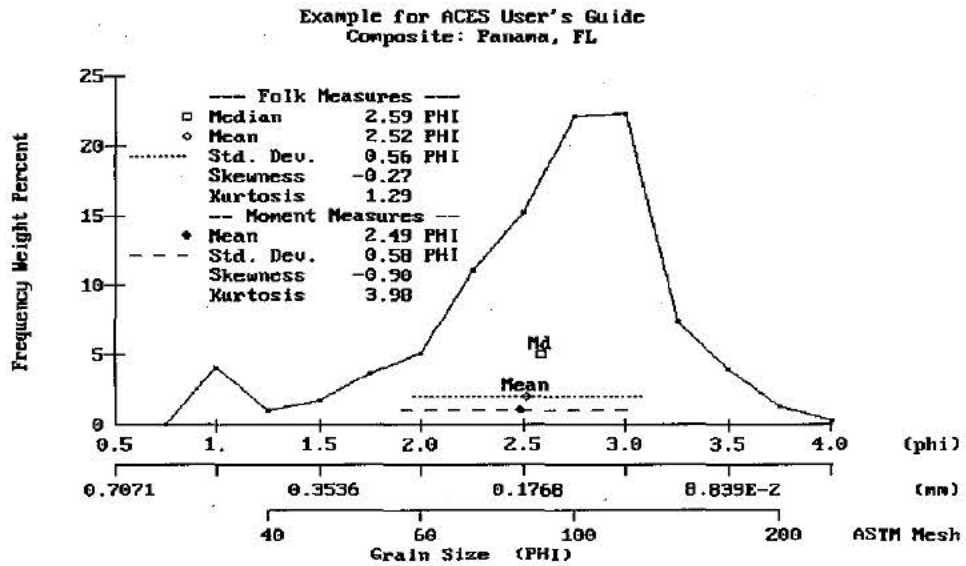

Figure 6-3-7. Frequency Weight Percent for Example Problem

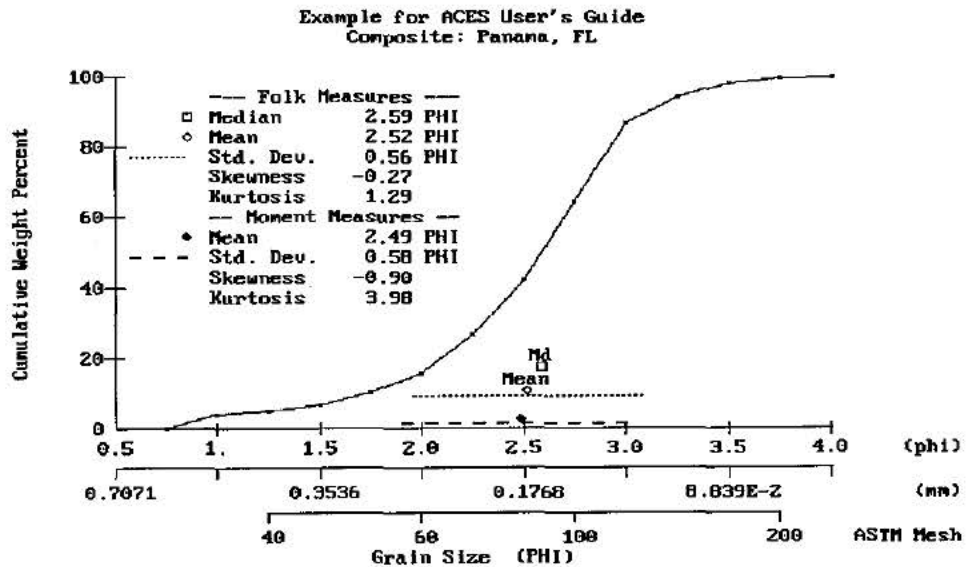

Figure 6-3-8. Cumulative Weight Percent for Example Problem

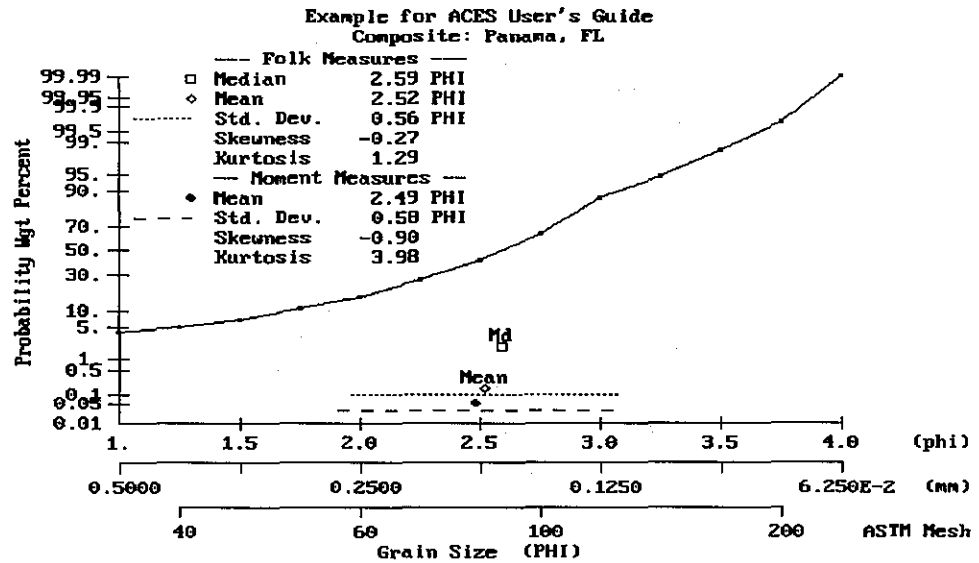

Figure 6-3-9. Probability Weight Percent for Example Problem

REFERENCES AND BIBLIOGRAPHY

- Folk, R. L. 1974. *Petrology of Sedimentary Rocks*, Hemphill Publishing Company, Austin, TX, pp. 183.
- Friedman, G. M., and Sanders, J. E. 1978. *Principles of Sedimentology*, John Wiley & Sons, New York, NY, Chapter 3.
- Hobson, R. D. 1977. "Review of Design Elements for Beach Fill Evaluation," Technical Paper 77-6, US Army Engineer Waterways Experiment Station, Vicksburg, MS.
- James, W. R. 1974. "Beach Fill Stability and Borrow Material Texture," *Proceedings of the 14th International Conference on Coastal Engineering*, American Society of Civil Engineers, pp. 1334-1349.
- James, W. R. 1975. "Techniques in Evaluating Suitability of Borrow Material for Beach Nourishment," Technical Memorandum No. 60, US Army Engineer Waterways Experiment Station, Vicksburg, MS.
- Krumbein, W. C. 1934. "Size Frequency Distribution of Sediments," *Journal of Sedimentary Petrology*, Vol. 4, pp. 65-77.
- Krumbein, W. C. 1938. "Size Frequency Distributions of Sediments and the Normal Phi Curve," *Journal of Sedimentary Petrology*, Vol. 18, pp. 84-90.
- Krumbein, W. C. 1957. "A Method for Specification of Sand for Beach Fills," Technical Memorandum No. 102, Beach Erosion Board, US Army Engineer Waterways Experiment Station, Vicksburg, MS.

Moussa, T. M. 1977. "Phi Mean and Phi Standard Deviation of Grain-Size Distribution in Sediments: Method of Moments," *Journal of Sedimentary Petrology*, Vol. 47, No. 3, pp. 1295-1298.

Shore Protection Manual. 1984. 4th ed., 2 Vols., US Army Engineer Waterways Experiment Station, Coastal Engineering Research Center, US Government Printing Office, Washington, DC, Chapter 5, pp. 6-24.

BEACH NOURISHMENT OVERFILL RATIO AND VOLUME

TABLE OF CONTENTS

Description	6-4-1
Input	6-4-1
Output	6-4-1
Procedure	6-4-2
Single Case Mode	6-4-2
Example Problem	6-4-3
Input	6-4-3
Output	6-4-3
References and Bibliography	6-4-3

BEACH NOURISHMENT OVERFILL RATIO AND VOLUME

DESCRIPTION

The methodologies represented in this ACES application provide two approaches to the planning and design of nourishment projects. The first approach is the calculation of the *overflow ratio*, which is defined as the volume of actual borrow material required to produce a unit volume of usable fill. The second approach is the calculation of a *renourishment factor* which is germane to the long-term maintenance of a project and addresses the basic question of how often renourishment will be required if a particular borrow source is selected that is texturally different from the native beach sand.

INPUT

All data input for this application is done on one screen. The following list describes the necessary input parameters with their corresponding units and range of data recognized by this application:

<u>Mandatory item</u>	<u>Symbol</u>	<u>Units</u>	<u>Data Range</u>
Initial Volume	VOL_I	yd ³ , m ³	1 to 1 x 10 ⁸
Native Mean	M_n	phi, mm	-5.0 to 5.0
Native Standard Deviation	σ_n	phi	0.01 to 5.0
Borrow Mean	M_b	phi, mm	-5.0 to 5.0
Borrow Standard Deviation	σ_b	phi	0.01 to 5.0

NOTE: Table A-4 in Appendix A provides a comparison of grain-size scales and classification systems.

OUTPUT

Results from this application are displayed on one screen. Those data include the original input values (in final units) and the following parameters:

<u>Item</u>	<u>Symbol</u>	<u>English Units</u>	<u>Metric Units</u>
Overfill Ratio	R_a		
Renourishment Factor	R_j		
Design Volume	VOL_D	yd ₃	m ₃

PROCEDURE

This application provides only a Single Case Mode. The Multiple Case Mode is not available. The bulleted items in the following lists indicate potentially optional instruction steps. Any application in ACES may be executed in a given session without quitting the program. The bulleted items provide instructions for accessing the application from various menu areas of the ACES program. Ignore bulleted instruction steps that are not applicable.

Single Case Mode

- ° Press **F1** on the Main Menu to select Single Case Mode.
 - ° Fill in the highlighted input fields on the General Specifications screen (or leave the default values). Press **F1** when all data on this screen are correct.
 - ° Press **F6** on the Functional Area Menu to select Littoral Processes.
 - ° Press **F4** on the Littoral Processes Application Menu to select Beach Nourishment Overfill Ratio and Volume.
1. Fill in the highlighted input fields on the Beach Nourishment Overfill Ratio and Volume screen. Respond to any corrective instructions appearing at the bottom of the screen. Press **F1** when all data on this screen are correct.
 2. All input and output data are displayed on the screen in the final system of units.
 3. Press one of the following keys to select the appropriate action:
 - F1** Return to Step 1 for a new case.
 - F3** Send a summary of this case to the print file or device.
 - F10** Exit this application and return to the Littoral Processes Menu.

EXAMPLE PROBLEM

Input

All data input for this application is done on one screen. The values and corresponding units selected for this example problem are shown below.

<u>Item</u>	<u>Symbol</u>	<u>Value</u>	<u>Units</u>
Initial Volume	VOL_I	800,000.0	yd ₃
Native Mean	M_n	1.800	phi
Native Standard Deviation	σ_n	0.450	phi
Borrow Mean	M_b	2.250	phi
Borrow Standard Deviation	σ_b	0.760	phi

Output

Results from this application are displayed on one screen. Those data include the original input values and the following parameters:

<u>Item</u>	<u>Symbol</u>	<u>Value</u>	<u>Units</u>
Overfill Ratio	R_a	2.003	
Renourishment Factor	R_j	1.077	
Design Volume	VOL_D	1,602,521.0	yd ₃

REFERENCES AND BIBLIOGRAPHY

- Hobson, R. D. 1977. "Review of Design Elements for Beach Fill Evaluation," Technical Paper 77-6, US Army Engineer Waterways Experiment Station, Vicksburg, MS.
- James, W. R. 1974. "Beach Fill Stability and Borrow Material Texture," *Proceedings of the 14th International Conference on Coastal Engineering*, American Society of Civil Engineers, pp.1334-1349.
- James, W. R. 1975. "Techniques in Evaluating Suitability of Borrow Material for Beach Nourishment," Technical Memorandum No. 60, US Army Engineer Waterways Experiment Station, Vicksburg, MS.
- Krumbein, W. C. 1934. "Size Frequency Distribution of Sediments," *Journal of Sedimentary Petrology*, Vol. 4, pp. 65-77.
- Krumbein, W. C. 1938. "Size Frequency Distributions of Sediments and the Normal Phi Curve," *Journal of Sedimentary Petrology*, Vol. 18, pp. 84-90.
- Krumbein, W. C. 1957. "A Method for Specification of Sand for Beach Fills," Technical Memorandum No. 102, Beach Erosion Board, US Army Engineer Waterways Experiment Station, Vicksburg, MS.

Shore Protection Manual. 1984. 4th ed., 2 Vols., US Army Engineer Waterways Experiment Station, Coastal Engineering Research Center, US Government Printing Office, Washington, DC, Chapter 5, pp. 6-24.

A SPATIALLY INTEGRATED NUMERICAL MODEL FOR INLET HYDRAULICS

TABLE OF CONTENTS

Description	7-1-1
Input	7-1-2
Output	7-1-2
Plot Output File 1	7-1-2
Plot Output File 2	7-1-3
Plot Output File 3	7-1-3
Procedure	7-1-3
Single Case Mode	7-1-3
Data Entry Options Menu	7-1-4
Initial Case Data Entry	7-1-4
Edit Case in External File: INLET.IN	7-1-4
Activity Menu	7-1-4
Begin Computations	7-1-4
General Time and Inlet Data Entry	7-1-5
Inlet(s) Cross-Section Data Entry	7-1-6
Sea(s) Boundary Condition (BC) Data Entry	7-1-8
Tabulated Data	7-1-8
Constituent Tide Data	7-1-9
Bay Boundary Condition Data Entry	7-1-10
Specify Velocity Output Locations	7-1-11
Plot Output Data	7-1-12
Example Problems	7-1-13
Example 1 - One-Inlet, One-Bay, and One-Sea System with Constituent Tide and River Discharge Data	7-1-13
Example 1 Input	7-1-13
General Time and Inlet Data Entry	7-1-13
Inlet(s) Cross-Section Data Entry	7-1-14
Sea(s) Boundary Condition Data Entry	7-1-16
Bay Boundary Condition Data Entry	7-1-16
Specify Velocity Output Locations	7-1-16
Example 1 Output	7-1-17
Plot Output File 1	7-1-17
Plot Output File 2	7-1-19
Plot Output File 3	7-1-20
Example 2 - One-Inlet, One-Bay, and One-Sea System with Tabulated Data	7-1-23
Example 2 Input	7-1-23
General Time and Inlet Data Entry	7-1-23
Inlet(s) Cross-Section Data Entry	7-1-24
Sea(s) Boundary Condition Data Entry	7-1-26
Bay Boundary Condition Data Entry	7-1-26
Specify Velocity Output Locations	7-1-26
Example 2 Output	7-1-27
Plot Output File 1	7-1-27
Plot Output File 2	7-1-29
Plot Output File 3	7-1-30
References and Bibliography	7-1-32

A SPATIALLY INTEGRATED NUMERICAL MODEL FOR INLET HYDRAULICS

DESCRIPTION

This application is a numerical model that estimates coastal inlet velocities, discharges, and bay levels as functions of time for a given time-dependent sea level fluctuation. Inlet hydraulics are predicted in this model by simultaneously solving the time-dependent momentum equation for flow in the inlet and the continuity equation relating the bay and sea levels to inlet discharge. The model is designed for cases where the bay water level fluctuates uniformly throughout the bay and the volume of water stored in the inlet between high and low water is negligible compared with the tidal prism of water that moves through the inlet and is stored in the bay. The model has been previously described by Seelig (1977) and Seelig, Harris, and Herchenroder (1977). Because of the complexity of this methodology and the input requirements, familiarization with the above references is strongly recommended.

An inlet-bay system typically consists of a *sea* (ocean or lake) connected to a *bay* by one or more *inlets*. Possible system configurations that this ACES application will run include:

- 1-Sea - 1-Inlet - 1-Bay System
- 1-Sea - 2-Inlet - 1-Bay System
- 2-Sea Boundary Condition - 2-Inlet - 1-Bay System (see Figure 7-1-1)

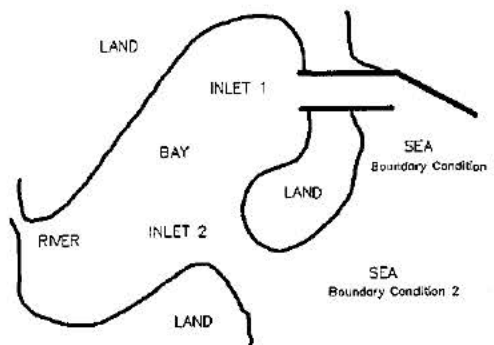

Figure 7-1-1. Conceptual 2-Sea, 2-Inlet, and 1-Bay System

CAUTION: Only the 1-Sea, 1-Inlet, 1-Bay System has been tested with this version of the model. Use the other system configurations with caution!

LIMITATION: The bay and inlet must contain water throughout the water level cycle. This application cannot treat shallow inlet areas that may be exposed (dry up) during any portion of the tidal cycle.

INPUT

The input requirements of this application consist of five general types of information:

- General data describing system configuration and temporal data.
- Inlet geometries characterized with cross-section tables and locations.
- Seaward boundary conditions (tabulated records or predicted tides using harmonic constituents).
- Bayside boundary conditions (bay area and shape factor, and other freshwater inflows distinct from inlet contributions).
- Locations where velocity hydrographs are to be reported from the simulation.

Data input to this application is accomplished through numerous input screens or through data saved in an external file. Detailed lists of the screens and input parameters are presented in the *Procedure* section of this document. Also, a review of the referenced documents is strongly recommended.

OUTPUT

Results from this application are written to the plot output files (1-3). The contents and organization of output data in the plot output files are summarized below. In addition, this application generates numerous screen plots (see section titled **Plot Output Data**).

Plot Output File 1

This file contains tabular summaries of grid characteristics for equal channel discharge (based upon an assumed representative velocity for the minimal cross section). The contents of the file are for general information only and are relative to assumptions made in constructing the flow net. The data are not results of the simulation using the time-dependent sea and bay hydrographs.

Summarized by channel for each cross section (for each inlet) are common geometric properties such as area, width, depth, and a weighting factor describing the flow distribution among the channels.

Also provided for each cross section is a table of discharge distribution and water depths for the entire cross section, tabulated at 100 equally spaced segments across the section. Finally, a table of friction loss (per foot of channel) is tabulated by cross section.

Plot Output File 2

This file contains a table of velocity hydrographs produced by the simulation at selected flow net cell locations. The velocities (feet per second) are reported at the *Tabular Output Time Interval* and represent the velocity condition at the centers of the selected flow net cells.

Plot Output File 3

This file contains elevation and discharge hydrographs for the sea boundary conditions (BC), bay, and inlet(s). Results are tabulated at the *Tabular Output Time Interval* and represent summary conditions at the indicated times for the entire system. Included are sea and bay elevations, riverine inflows, average velocity at the controlling cross section, and inlet discharge.

A final table is provided that summarizes flood and ebb regimes and volumes identified during the simulation.

PROCEDURE

This application provides only a Single Case Mode. The Multiple Case Mode is not available. The Single Case Mode requires interaction with the application and provides two options of interactive participation. The first option allows entering new data sets, and the second option allows the editing of existing data files.

Single Case Mode

- Press **(F1)** on the Main Menu to select Single Case Mode.
- Fill in the highlighted input fields on the General Specifications screen (or leave the default values). Press **(F1)** when all data on this screen are correct.
- Press **(F7)** on the Functional Area Menu to select Inlet Processes.
- Press **(F1)** on the Inlet Processes Menu to select A Spatially Integrated Numerical Model for Inlet Hydraulics.

Data Entry Options Menu

This menu provides two options of interactive participation with the application.

(F1) Initial Case Data Entry

Use this option to enter an initial (new) set of data. These data will be written to the *Trace Output* file (default name **TRACE.OUT**) and become available for subsequent editing and use.

(Alt) (F1) Edit Case in External File: INLET.IN

Use this option to access and modify data saved in an external file. This external data file is created by saving (or copying) a *trace file* from a previous execution of this application. The format and contents of the *trace file* for this application match exactly the requirements of this input file. The default input file name is **INLET.IN**, but other file names (including path name) are acceptable. After entering the file name, press **(ENTER)** to accept this file. *For more information on files, see the section of this manual entitled, "General Instructions and Information."*

Activity Menu

The Activity Menu is a point from which all options for Single Case data entry, modification, and execution are accessible. The options are:

- (F1)** Begin Computations.
- (F2)** General Time and Inlet Data Entry.
- (F3)** Inlet(s) Cross-Section Data Entry.
- (F4)** Sea(s) Boundary Condition Data Entry.
- (F5)** Bay Boundary Condition Data Entry.
- (F6)** Specify Velocity Output Locations.
- (F7)** Plot Output Data.
- (F10)** Exit Menu.

Each option and the required data are described below.

(F1) Begin Computations

Use this option only after all data have been entered.

F2) General Time and Inlet Data Entry

This screen provides for input of general parameters required to run the application. Values for all parameters listed are required.

<u>Item</u>	<u>Units</u>	<u>Data Range</u>
Profile point units	ft,m	
Simulation start time:		
Year		1900 to 2050
Month		1 to 12
Day		1 to 31
Hour		0 to 24
Time step	sec	60 to 300
Length of simulation	hr	0 to 48
Tabular output time interval	min	2 to 360

NOTE: The tabular output time interval must be a multiple of the time step, and, at a minimum, it must be at least twice the time step.

Number of inlets	1 or 2
Number of bays	1
Number of seaward boundary condition locations	1 or 2

The following data are required for each inlet:

Number of channels	1	to	7
Number of cross sections	1	to	16
Flood loss coefficient	0.0	to	10.0
Ebb loss coefficient	0.1	to	10.0
Coefficient C_1 to evaluate Manning's n	0.001	to	3.0
Coefficient C_2 to evaluate Manning's n	0.00001	to	1.0

NOTE: After completing data entry on this screen, press **F10** to return to the Activity Menu.

F3 Inlet(s) Cross-Section Data Entry

This series of screens provides for input of data that will be used to construct a flow net (or grid) for the inlet(s). The flow net is used to characterize hydraulic properties and bottom friction throughout the inlet (see Seelig, Harris, and Herchenroder, 1977, Appendix B). This application will accept 1 or 2 inlets with a maximum of 16 cross sections per inlet. Each cross section can be defined by a maximum of 54 elevations spaced at a constant distance (ΔX). Cross sections should be indexed in ascending order from sea to bay through the inlet. Channels are indexed in ascending order from left to right (from a seaward perspective). In Figure 7-1-2 a flow net with six channels and eight cross sections is depicted. Figure 7-1-3 shows a simple cross section consisting of nine equally spaced elevation points.

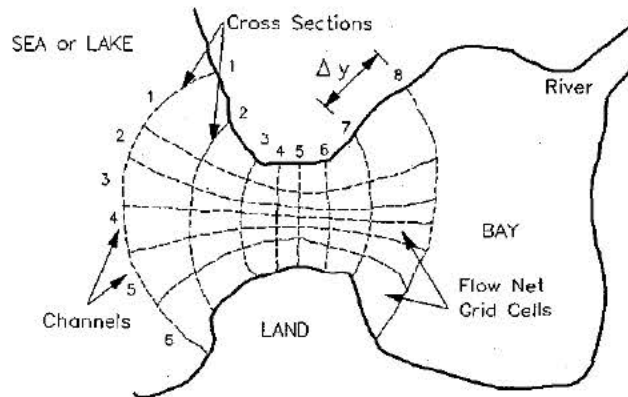

Figure 7-1-2. Typical Inlet Flow Net

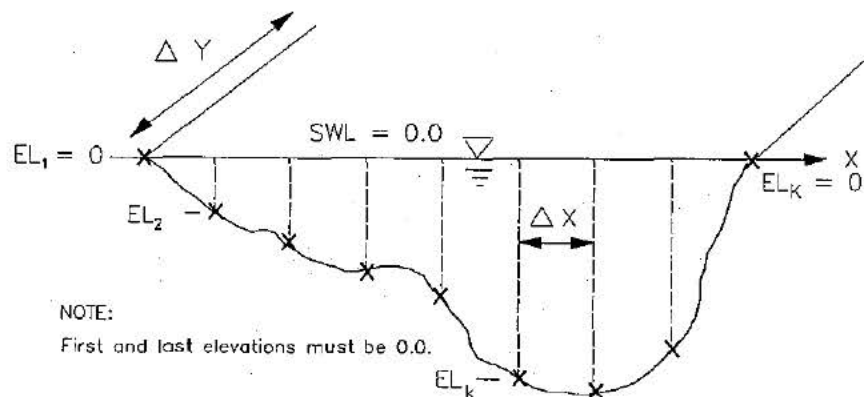

Figure 7-1-3. Typical Inlet Cross Section

<u>Item/Description</u>	<u>Units</u>	<u>Data Range</u>
Inlet _i - (index)		1 or 2
Cross section _j - (index)		1 to 16

Press **(F1)** to access the screen for input of specific cross-section data.

ΔX - horizontal spacing of cross-section points ft,m 1.0 to 5,000.0

NOTE: This distance should be small enough so that linear interpolation between elevation readings will adequately describe the bottom topography for each cross section.

ΔY - distance to the next cross section ft,m 5.0 to 10,000.0

NOTE: For the last cross section, the ΔY must be 0.0.

EL_k - cross-section elevations relative to still-water level ($k = 1 \dots K$, $K \leq 54$) -999.999 to 0.0

CAUTION: The first and last elevation on each cross section *must* be 0.0. Because the inlet must contain water throughout the water level cycle, cross-section elevations throughout the inlet should exceed the lowest point in the water cycle.

NOTE: If there are more than 27 elevation points for the selected cross section, press **(F1)** to access another screen for entering remaining (27 through 54) elevation values. After completing elevation data entry for one cross section, press **(F10)** to return to the Activity Menu. Then press **(F3)** to continue entering elevation data for the next cross section.

F4 Sea(s) Boundary Condition (BC) Data Entry

This series of screens provides for the input of the seaward-side forcing boundary conditions for the model. Water levels may be described by *tabulated* entries (120 maximum) collected at a constant sampling interval. Alternately, tides can be expressed as a *constituent* tide record with an amplitude and epoch for any of 37 constituents (see Table A-5, Appendix A).

<u>Item/Description</u>	<u>Units</u>	<u>Data Range</u>
Sea BC ₁ - (index)		1 or 2
Sea BC type - (constituent or tabulated)		Tab or Con
Sea BC Δt - time interval for tabulated or generated BC hydrograph record	min	0.0 to 720.0

Press **F1** to continue input.

Tabulated Data

<u>Item/Description</u>	<u>Units</u>	<u>Data Range</u>
Sea BC elevation units	ft, m	
Press F1 to continue <i>tabulated data</i> input.		
Sea BC EL _m ($m = 1..M$, $M \leq 120$)	ft,m	-999.99 to 9,999.99

NOTE: Each screen will accept a maximum of 30 values. Press **F1** to continue *tabulated* input (maximum 120 values). When finished entering all elevation data, press **F10** to return to the Activity Menu.

CAUTION: The simulation begins with a sea level of zero and zero current, which means the sea boundary condition should reflect these conditions. This can be achieved by ensuring that tabulated entries begin with a gradual change (slope of the forcing boundary condition time series is near zero at the beginning of the simulation).

NOTE: The total time span for tabulated water levels must equal or exceed the *Length of Simulation*. For example, if the time interval between tabulated water level entries is 30 minutes and there are 77 entries, then the *Length of Simulation* must be less than or equal to 38 hours.

$$\frac{(77 - 1) * 30 \text{ minutes}}{60 \text{ minutes}} = 38 \text{ hours}$$

Constituent Tide Data

<u>Item/Description</u>	<u>Units</u>	<u>Data Range</u>
Sea BC longitude	deg WEST	-180.0 to 180.0
Sea BC amplitude units	ft,m	

Press **F1** to continue *constituent tide data* input.

Amplitude _n of individual constituent _n	ft,m	0.0 to 999.99
Epoch _n of individual constituent _n	deg	0.0 to 360.0

NOTE: The names of 37 common harmonic constituents (see Table A-5, Appendix A) are displayed on a series of screens. Place the values of amplitude and epoch by the appropriate desired constituent name. Press **F1** to continue additional *constituent* input on subsequent screens. When finished entering all data, press **F10** to return to the Activity Menu.

F5 Bay Boundary Condition Data Entry

This series of screens provides for the input of bay characteristics and inflows from a source (river) other than the inlet. Bay surface area is the only required input.

<u>Item/Description</u>	<u>Units</u>	<u>Data Range</u>
Area - bay surface area	ft ² , m ²	9x10 ⁴ to 1x10 ¹⁰
Bay α - bay area variation parameter		0.0 to 3.3

Press **F1** to continue input.

Inflow Δt - time interval for river discharge inflow hydrograph	min	0.0 to 720.0
---	-----	--------------

Inflow Q units - river discharge units	cfs,cms	
--	---------	--

Press **F1** to access the screen for entering tabulated river discharge data.

Inflow Q _{ii} (ii = 1...II, II, ≤ 120) - tabulated values of river inflow discharges	cfs,cms	0.0 to 9,999.99
---	---------	-----------------

NOTE: If there are more than 30 discharge values to be entered, press **F1** to access subsequent screens for entering the remaining values (each screen will allow input of 30 values). After completing discharge data entry, press **F10** to return to the Activity Menu.

CAUTION: Because the simulation begins with zero current in the inlet, it is advisable to begin any river discharge with zero inflow and gradually build up to the desired hydrograph for the simulation.

NOTE: The total time span for tabulated river discharge inflow must equal or exceed the *Length of Simulation*. For example, if the time interval between river discharge inflow entries is 240 minutes and there are nine entries, then the *Length of Simulation* must be less than or equal to 32 hours.

$$\frac{(9 - 1) * 240 \text{ minutes}}{60 \text{ minutes}} = 32 \text{ hours}$$

F6 Specify Velocity Output Locations

This series of screens provides for input of specific cell locations in the flow net grid where inlet velocities are desired (see Figure 7-1-4). Inlet velocities are computed at the specified *Time Step* at all grid cells, but only values at the *Tabular Output Time Interval* and at the specified cell locations are saved for output. The computed velocities are at the center of the flow net cells (see figure below). These velocity values are written to plot output file 2. A maximum of 20 locations can be identified, and a minimum of 1 location is required.

<u>Item/Description</u>	<u>Units</u>	<u>Data Range</u>
Inlet _{ii} - (index)		1 or 2
Cross Section _{jj} - (index)		1 to 15
Channel _{kk} - (index)		1 to 6

NOTE: If there are more than 10 grid cells to be specified, press **F1** to access another screen for inputting the remaining (11-20) cell locations. After completing grid cell location data entry, press **F10** to return to the Activity Menu.

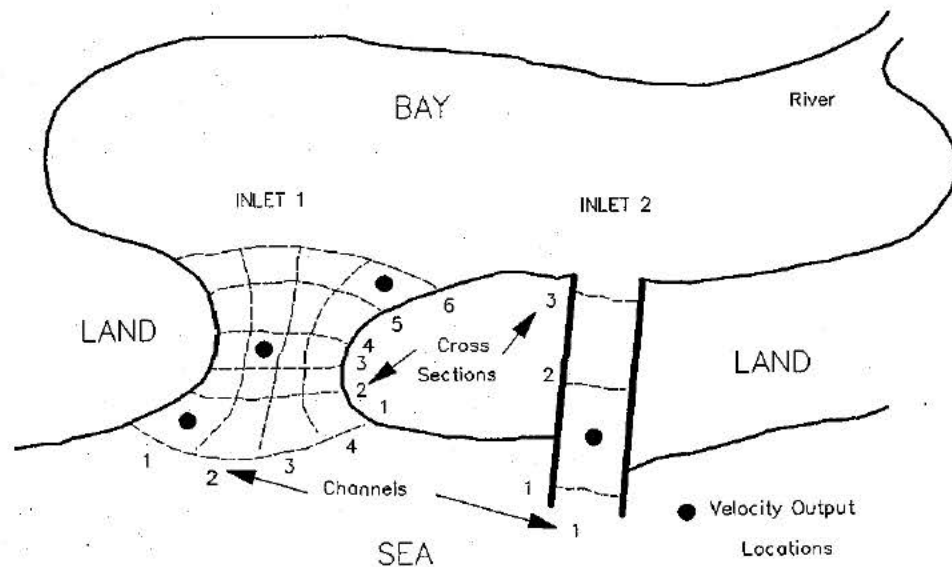

Figure 7-1-4. Typical Velocity Output Locations

For example, in Figure 7-1-4, four cell locations for a 1-sea, 2-inlet, 1-bay system are shown. A cell is referenced by Inlet, Cross Section, and Channel numbers.

Inlet - 1; Cross Section - 1; Channel - 1
 Inlet - 1; Cross Section - 3; Channel - 2
 Inlet - 1; Cross Section - 5; Channel - 4
 Inlet - 2; Cross Section - 1; Channel - 1

F7 Plot Output Data

This application generates numerous plots. The plots may be accessed from the **INLET PLOT SELECTION MENU**, which appears when the **Plot Output Data** option is requested. To access a plot, move the cursor (using the arrow keys) to the desired plot and press **F1**. (Appendix C describes options to customize plots.) Available plots are:

- Predicted Water Velocities at Specified Cells (see Figure 7-1-5 of Example Problem 1)

NOTE: This option displays a menu for selecting specific cells for which predicted water velocities are to be plotted. Use the arrow keys to move the cursor to the desired cells and enter an x. When finished selecting the cells, press **F1** to begin plotting. If more than one cell was selected, use the **NEXT** option of the graphics package (Appendix C) to view each plot successively.

- Sea & Bay Elevations at Each Inlet (see Figure 7-1-6 of Example Problem 1)
- Riverine Inflow (see Figure 7-1-7 of Example Problem 1)
- Predicted Velocity at the Controlling Cross Section (Figure 7-1-8 of Example Problem 1)
- Discharge at Each Inlet (see Figure 7-1-9 of Example Problem 1)
- **ALL PLOTS**

NOTE: This option will make all the plots available for viewing. Use the **NEXT** option of the graphics package (Appendix C) to view each plot successively.

- **EXIT MENU**

EXAMPLE PROBLEMS**Example 1 - One-Inlet, One-Bay, and One-Sea System with Constituent Tide and River Discharge Data****Example 1 Input**

All input is accomplished through screens accessible from the Activity Menu.

F2) General Time and Inlet Data Entry

Simulation start time:

Year	1988
Month	7
Day	6
Hour	0.00
Time step	60 sec
Length of simulation	30 hr
Tabular output time interval	15 min
Number of inlets	1
Number of bays	1
Number of seaward boundary condition locations	1

Inlet 1

Number of channels	4
Number of cross sections	5
Flood loss coefficient	4.00
Ebb loss coefficient	1.00
Coefficient C_1 to evaluate Manning's n	0.05
Coefficient C_2 to evaluate Manning's n	0.0007

(Example 1 Input Continued)

F3 Inlet(s) Cross-Section Data Entry

Data for five cross sections will be used in this first example.

Inlet 1 Cross Section 1 $\Delta X = 104.00$ ft $\Delta Y = 1750.00$ ft**Elevations (ft)**

1	0.0	16	-13.0	31	-32.0
2	-27.0	17	-13.0	32	-24.0
3	-27.0	18	-13.0	33	-24.0
4	-27.0	19	-13.0	34	-24.0
5	-27.0	20	-18.0	35	-24.0
6	-27.0	21	-24.0	36	-25.0
7	-27.0	22	-30.0	37	-25.0
8	-27.0	23	-32.0	38	-18.0
9	-27.0	24	-34.0	39	-18.0
10	-27.0	25	-34.0	40	-18.0
11	-27.0	26	-34.0	41	-18.0
12	-18.0	27	-34.0	42	0.0
13	-13.0	28	-32.0		
14	-13.0	29	-32.0		
15	-13.0	30	-32.0		

Inlet 1 Cross Section 2 $\Delta X = 104.00$ ft $\Delta Y = 1625.00$ ft**Elevations (ft)**

1	0.0	6	-34.0	11	-30.0
2	-30.0	7	-34.0	12	-30.0
3	-33.0	8	-34.0	13	-20.0
4	-33.0	9	-34.0	14	-10.0
5	-33.0	10	-34.0	15	0.0

(Example 1 Input Continued)

Inlet 1 Cross Section 3

$\Delta X = 104.00$ ft

$\Delta Y = 1917.00$ ft

Elevations (ft)

1	0.0	9	-34.0	17	-8.0
2	-12.0	10	-34.0	18	-8.0
3	-18.0	11	-34.0	19	-8.0
4	-20.0	12	-34.0	20	-6.0
5	-25.0	13	-34.0	21	-6.0
6	-30.0	14	-30.0	22	-6.0
7	-33.0	15	-18.0	23	-6.0
8	-34.0	16	-12.0	24	0.0

Inlet 1 Cross Section 4

$\Delta X = 104.00$ ft

$\Delta Y = 1250.00$ ft

Elevations (ft)

1	0.0	6	-50.0	11	-34.0
2	-18.0	7	-50.0	12	-24.0
3	-37.0	8	-34.0	13	-18.0
4	-37.0	9	-34.0	14	0.0
5	-50.0	10	-34.0		

Inlet 1 Cross Section 5

$\Delta X = 104.00$ ft

$\Delta Y = 0.00$ ft

Elevations (ft)

1	0.0	13	-18.0	25	-10.0
2	-11.0	14	-25.0	26	-10.0
3	-11.0	15	-25.0	27	-10.0
4	-11.0	16	-20.0	28	-10.0
5	-12.0	17	-20.0	29	-10.0
6	-12.0	18	-20.0	30	-10.0
7	-17.0	19	-34.0	31	-10.0
8	-17.0	20	-34.0	32	-10.0
9	-17.0	21	-34.0	33	-10.0
10	-15.0	22	-34.0	34	-10.0
11	-15.0	23	-23.0	35	-10.0
12	-15.0	24	-18.0	36	-10.0
				37	0.0

(Example 1 Input Continued)

(F4) Sea(s) Boundary Condition Data Entry

Sea BC 1
 Sea BC type Con
 Sea BC Δt 15.00 min
 Sea BC longitude 75.00 deg WEST
 Sea BC amplitude units ft
 Length of simulation 30 hr
 Tabular output time interval 15 min

Constituent tide data

Harmonic Constituent	Amplitude (ft)	Epoch (deg)
M2	2.0	90.0

NOTE: All other harmonic constituents are zero for this example problem.

(F5) Bay Boundary Condition Data Entry

Bay 1
 Bay surface area 1.80E+9 ft²
 Bay area variation parameter α 0.00
 Inflow Δt 260.00 min
 Inflow Q units cfs

River Discharge (cfs)

1	4000.0	4	3200.0	7	4200.0
2	3800.0	5	3500.0	8	4300.0
3	3600.0	6	3800.0	9	4500.0

(F6) Specify Velocity Output Locations

<u>Inlet</u>	<u>Cross Section</u>	<u>Channel</u>
1	2	2
1	2	1
1	2	3
1	2	4

Example 1 Output

Results from this application are written to three plot output files. In addition, this application generates numerous screen plots.

Plot Output File 1

This file contains tabular summaries of various grid characteristics for equal channel discharge. Summarized by channel for each cross section (for each inlet) are common geometric properties such as area, width, depth, and a weighting factor describing the flow distribution among all the channels. Also provided for each cross section is a table of discharge distribution and water depths for the entire cross section, tabulated at 100 equally spaced segments across the section. Finally, a table of friction loss (per foot of channel) is tabulated by cross section. Table 7-1-1 is a partial list of the data in the output file 1 (default name **PLOTDAT1.OUT**) for cross sections 1 and 5 only.

Table 7-1-1
Partial Listing of Plot Output File 1 for Example Problem 1

Inlet 1 Cross Section 1

Total area (ft ²)	100360.00			
Total width (ft)	4264.00			
Channel ->	1	2	3	4
Area (ft ²)	23245.7	36558.4	9483.8	31071.7
Width (ft)	912.9	1708.6	288.0	1354.5
Depth (ft)	25.5	21.4	32.9	22.9
Weight	0.2521	0.2458	0.2513	0.2508
X	Discharge (cfs)		Depths (ft)	
42.661	0.015		5.541	
85.323	0.209		16.622	
127.984	0.894		25.949	
170.645	1.029		27.014	
213.307	1.029		27.014	
255.968	1.029		27.014	
298.629	1.029		27.014	
341.291	1.029		27.014	
383.952	1.029		27.014	
↓	↓		↓	
4095.491	0.235		18.009	
4138.152	0.235		18.009	
4180.813	0.204		17.128	
4223.474	0.055		10.712	
4266.135	0.004		3.334	

(Table 7-1-1 Continued on the Next Page)

(Example 1 Output Continued)

(Table 7-1-1 Concluded)

Inlet 1 Cross Section 5

Total area (ft²) 60112.00
 Total width (ft) 3744.00

Channel ->	1	2	3	4
Area (ft ²)	22912.5	6873.2	5186.1	25139.6
Width (ft)	1507.7	325.9	155.5	1754.9
Depth (ft)	15.3	24.3	34.0	14.7
Weight	0.2850	0.3649	0.0600	0.2901

X	Discharge (cfs)	Depths (ft)
37.459	0.002	1.982
74.917	0.024	5.946
112.376	0.087	9.810
149.835	0.117	11.006
187.294	0.117	11.006
224.752	0.117	11.006
262.211	0.117	11.006
299.670	0.117	11.006
337.129	0.119	11.087
374.587	0.130	11.427
↓	↓	↓
3633.498	0.090	10.005
3670.956	0.064	8.773
3708.415	0.017	5.225
3745.874	0.020	1.626

Summary of Friction Losses

Section	Friction Loss/ft of Channel Length (dimensionless)
1	43.992
2	2.460
3	14.245
4	3.332
5	35.970

(Example 1 Output Continued)

Plot Output File 2

This file (Table 7-1-2, default name **PLOTDAT2.OUT**) contains a table of velocity hydrographs produced by the simulation at selected flow net cell locations. The velocities (feet per second) are reported at the *Tabular Output Time Interval* and represent the velocity condition at the centers of the selected flow net cells. Figure 7-1-5 is a velocity hydrograph at cell (1,2,2) of the inlet.

Table 7-1-2
Listing of Plot Output File 2 for Example Problem 1

Hour	(1,2,2)	(1,2,1)	(1,2,3)	(1,2,4)
0.27	-6.42	-2.53	-6.56	-1.56
0.50	-9.02	-3.55	-9.21	-2.18
0.77	-10.12	-3.97	-10.33	-2.44
1.00	-10.63	-4.16	-10.85	-2.55
1.27	-11.00	-4.30	-11.23	-2.62
1.50	-11.19	-4.36	-11.43	-2.66
1.77	-11.26	-4.38	-11.50	-2.67
2.00	-11.19	-4.35	-11.43	-2.64
↓	↓	↓	↓	↓
28.00	-10.50	-4.08	-10.73	-2.48
28.27	-9.55	-3.71	-9.76	-2.25
28.50	-8.55	-3.32	-8.73	-2.02
28.77	-7.16	-2.79	-7.32	-1.70
29.00	-5.67	-2.21	-5.79	-1.35
29.27	-3.49	-1.36	-3.56	-0.83
29.50	-0.81	-0.32	-0.83	-0.19
29.77	3.45	1.35	3.52	0.83
30.00	5.48	2.16	5.60	1.33

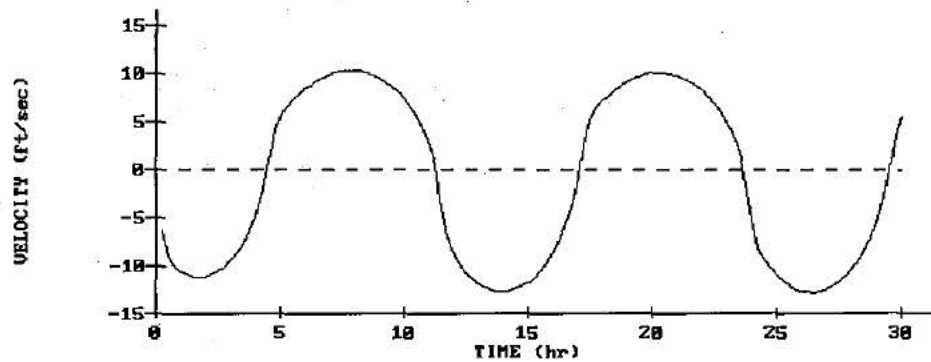

Figure 7-1-5. Velocity Hydrograph at Cell (1,2,2)

(Example 1 Output Continued)

Plot Output File 3

This file contains elevation and discharge hydrographs for the sea boundary conditions, bay, and inlet(s). Results are tabulated at the *Tabular Output Time Interval* and represent summary conditions at the indicated times for the entire system. Included in the file are sea and bay elevations, riverine inflows, average velocity at the controlling cross section, and inlet discharge. Also included in the file is a summary of flood and ebb regimes and volumes identified during the simulation. Table 7-1-3 is a partial listing of data contained in plot output file 3 (default name **PLOTDAT3.OUT**). Figures 7-1-6 through 7-1-9 are hydrograph plots of these parameters.

Table 7-1-3
Partial Listing of Plot Output File 3 for Example Problem 1

Time (hr)	Sea El (ft)	Bay El (ft)	Riverine Inflow (cfs)	Controlling Section Vel (cfs)	Inlet Q (cfs)
0.27	-0.80	-0.03	3993.10	-2.90	-123469.20
0.50	-1.00	-0.10	3985.94	-4.07	-172096.80
0.77	-1.21	-0.20	3976.59	-4.56	-191325.90
1.00	-1.38	-0.29	3967.49	-4.78	-199430.30
1.27	-1.55	-0.39	3956.17	-4.94	-204821.00
1.50	-1.67	-0.49	3945.55	-5.02	-207072.10
1.63	-1.73	-0.54	3939.24	-5.04	-207424.60
1.73	-1.77	-0.58	3934.39	-5.05	-207260.20
1.77	-1.79	-0.60	3932.75	-5.05	-207125.00
↓	↓	↓	↓	↓	↓
28.77	-1.47	-1.10	4269.00	-3.21	-131937.30
29.00	-1.31	-1.15	4271.69	-2.55	-104957.00
29.27	-1.11	-1.20	4275.25	-1.57	-64973.95
29.50	-0.92	-1.21	4278.98	-0.36	-15196.69
29.53	-0.89	-1.22	4279.58	0.15	-6093.05
29.77	-0.68	-1.20	4284.22	0.55	65138.12
30.00	-0.46	-1.16	4289.85	2.47	104461.80

Inlet #1	Start Time	End Time	Volume (ft ³ x1000)
Ebb	0.03	4.47	-2551027.00
Flood	4.50	11.30	3883867.00
Ebb	1.33	17.10	-3765760.00
Flood	17.13	23.67	3693283.00
Ebb	23.70	29.53	-3843678.00
Flood	29.57	30.00	99142.08

(Example 1 Output Continued)

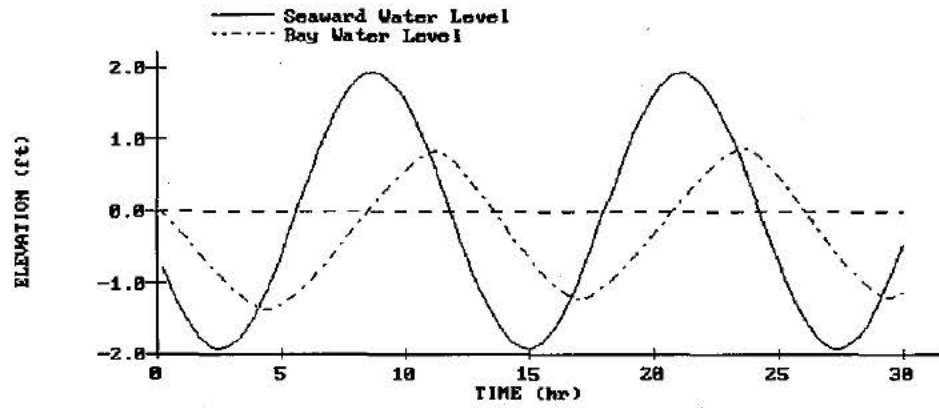

Figure 7-1-6. Sea and Bay Water Elevations at Inlet 1

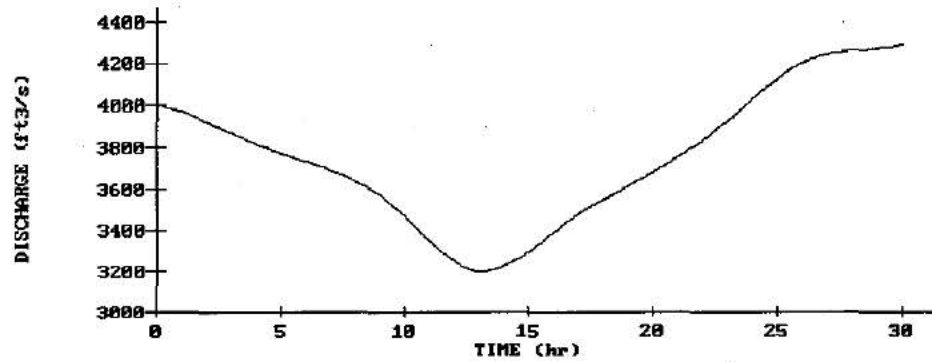

Figure 7-1-7. Riverine Inflow

(Example 1 Output Continued)

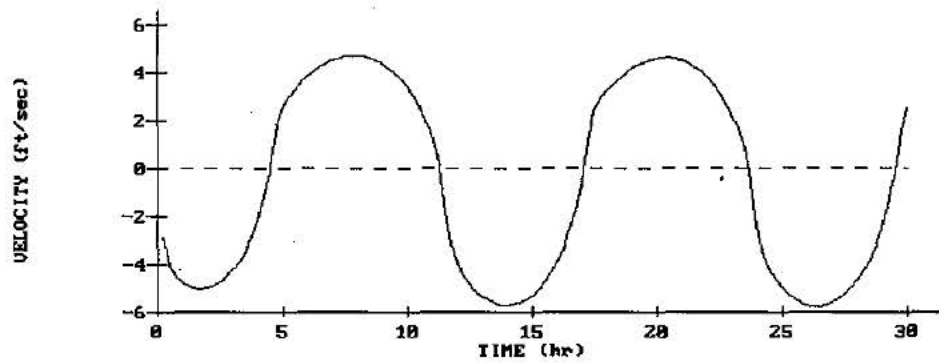

Figure 7-1-8. Average Velocity at Controlling Cross Section

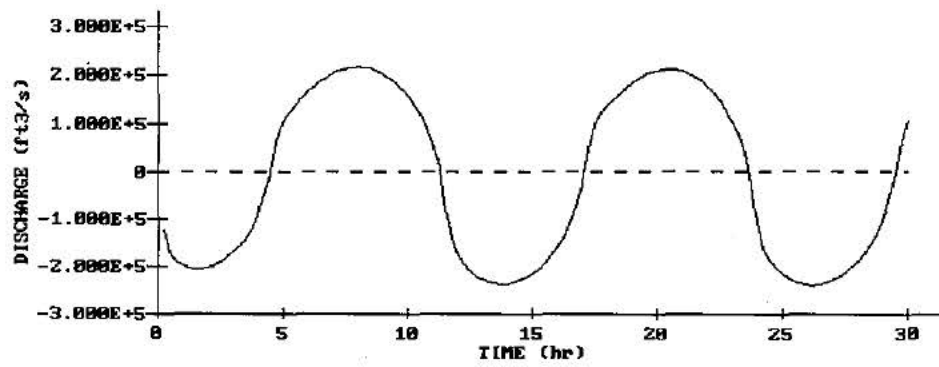

Figure 7-1-9. Inlet Discharge

Example 2 - One-Inlet, One-Bay, and One-Sea System with Tabulated Data**Example 2 Input**

All input is accomplished through screens accessible from the Activity Menu.

F2 General Time and Inlet Data Entry

Simulation start time:

Year	1988
Month	8
Day	23
Hour	12.00
Time step	60 sec
Length of simulation	38 hr
Tabular output time interval	30 min
Number of inlets	1
Number of bays	1
Number of seaward boundary condition locations	1

Inlet 1

Number of channels	4
Number of cross sections	5
Flood loss coefficient	4.00
Ebb loss coefficient	1.00
Coefficient C_1 to evaluate Manning's n	0.05
Coefficient C_2 to evaluate Manning's n	0.0007

(Example 2 Input Continued)

F3 Inlet(s) Cross-Section Data Entry

Data for five cross sections will be used in this second example.

Inlet 1 Cross Section 1

$\Delta X = 104.00$ ft

$\Delta Y = 1750.00$ ft

Elevations (ft)

1	0.0	16	-13.0	31	-32.0
2	-27.0	17	-13.0	32	-24.0
3	-27.0	18	-13.0	33	-24.0
4	-27.0	19	-13.0	34	-24.0
5	-27.0	20	-18.0	35	-24.0
6	-27.0	21	-24.0	36	-25.0
7	-27.0	22	-30.0	37	-25.0
8	-27.0	23	-32.0	38	-18.0
9	-27.0	24	-34.0	39	-18.0
10	-27.0	25	-34.0	40	-18.0
11	-27.0	26	-34.0	41	-18.0
12	-18.0	27	-34.0	42	0.0
13	-13.0	28	-32.0		
14	-13.0	29	-32.0		
15	-13.0	30	-32.0		

Inlet 1 Cross Section 2

$\Delta X = 104.00$ ft

$\Delta Y = 1625.00$ ft

Elevations (ft)

1	0.0	6	-34.0	11	-30.0
2	-30.0	7	-34.0	12	-30.0
3	-33.0	8	-34.0	13	-20.0
4	-33.0	9	-34.0	14	-10.0
5	-33.0	10	-34.0	15	0.0

(Example 2 Input Continued)

Inlet 1 Cross Section 3

$\Delta X = 104.00$ ft

$\Delta Y = 1917.00$ ft

Elevations (ft)

1	0.0	9	-34.0	17	-8.0
2	-12.0	10	-34.0	18	-8.0
3	-18.0	11	-34.0	19	-8.0
4	-20.0	12	-34.0	20	-6.0
5	-25.0	13	-34.0	21	-6.0
6	-30.0	14	-30.0	22	-6.0
7	-33.0	15	-18.0	23	-6.0
8	-34.0	16	-12.0	24	0.0

Inlet 1 Cross Section 4

$\Delta X = 104.00$ ft

$\Delta Y = 1250.00$ ft

Elevations (ft)

1	0.0	6	-50.0	11	-34.0
2	-18.0	7	-50.0	12	-24.0
3	-37.0	8	-34.0	13	-18.0
4	-37.0	9	-34.0	14	0.0
5	-50.0	10	-34.0		

Inlet 1 Cross Section 5

$\Delta X = 104.00$ ft

$\Delta Y = 0.00$ ft

Elevations (ft)

1	0.0	13	-18.0	25	-10.0
2	-11.0	14	-25.0	26	-10.0
3	-11.0	15	-25.0	27	-10.0
4	-11.0	16	-20.0	28	-10.0
5	-12.0	17	-20.0	29	-10.0
6	-12.0	18	-20.0	30	-10.0
7	-17.0	19	-34.0	31	-10.0
8	-17.0	20	-34.0	32	-10.0
9	-17.0	21	-34.0	33	-10.0
10	-15.0	22	-34.0	34	-10.0
11	-15.0	23	-23.0	35	-10.0
12	-15.0	24	-18.0	36	-10.0
				37	0.0

(Example 2 Input Continued)

(F4) Sea(s) Boundary Condition Data Entry

Sea BC 1
 Sea BC type Tab
 Sea BC Δt 30.00 min

Tabulated Time-Series Data Elevations (ft)

1	-0.500	21	1.550	41	0.640	61	0.340
2	-0.490	22	1.650	42	0.480	62	0.450
3	-0.470	23	1.740	43	0.320	63	0.560
4	-0.430	24	1.820	44	0.180	64	0.680
5	-0.370	25	1.890	45	0.060	65	0.800
6	-0.300	26	1.940	46	-0.050	66	0.920
7	-0.220	27	1.980	47	-0.150	67	1.030
8	-0.120	28	2.000	48	-0.220	68	1.140
9	-0.020	29	2.000	49	-0.270	69	1.250
10	0.100	30	1.980	50	-0.300	70	1.350
11	0.220	31	1.940	51	-0.300	71	1.440
12	0.350	32	1.880	52	-0.290	72	1.530
13	0.490	33	1.790	53	-0.260	73	1.600
14	0.630	34	1.690	54	-0.230	74	1.670
15	0.770	35	1.570	55	-0.180	75	1.720
16	0.910	36	1.430	56	-0.110	76	1.760
17	1.050	37	1.280	57	-0.040	77	1.780
18	1.190	38	1.130	58	0.040	78	1.800
19	1.310	39	0.970	59	0.130		
20	1.440	40	0.800	60	0.230		

(F5) Bay Boundary Condition Data Entry

Bay 1
 Bay Surface Area 1.80E+9 ft²
 Bay Area Variation Parameter α 0.00
 Inflow Δt 0 min
 Inflow Q units cfs

(F6) Specify Velocity Output Locations

<u>Inlet</u>	<u>Cross Section</u>	<u>Channel</u>
1	2	2
1	2	1
1	2	3
1	2	4

Example 2 Output

Results from this application are written to three plot output files. In addition, this application generates numerous screen plots.

Plot Output File 1

This file contains tabular summaries of various grid characteristics for equal channel discharge. Summarized by channel for each cross section (for each inlet) are common geometric properties such as area, width, depth, and a weighting factor describing the flow distribution among all the channels. Also provided for each cross section is a table of discharge distribution and water depths for the entire cross section, tabulated at 100 equally spaced segments across the section. Finally, a table of friction loss (per foot of channel) is tabulated by cross section. Table 7-1-4 is a partial list of the data in the output file 1 (default name **PLOTDAT1.OUT**) for cross sections 1 and 5 only.

Table 7-1-4

Partial Listing of Plot Output File 1 for Example Problem 2

Inlet 1 Cross Section 1

Total area (ft ²)	100360.00
Total width (ft)	4264.00

Channel ->	1	2	3	4
Area (ft ²)	23245.7	36558.4	9483.8	31071.7
Width (ft)	912.9	1708.6	288.0	1354.5
Depth (ft)	25.5	21.4	32.9	22.9
Weight	0.2521	0.2458	0.2513	0.2508

X	Discharge (cfs)	Depths (ft)
42.661	0.015	5.541
85.323	0.209	16.622
127.984	0.894	25.949
170.645	1.029	27.014
213.307	1.029	27.014
255.968	1.029	27.014
298.629	1.029	27.014
341.291	1.029	27.014
↓	↓	↓
4138.152	0.235	18.009
4180.813	0.204	17.128
4223.474	0.055	10.712
4266.135	0.004	3.334

(Table 7-1-4 Continued on the Next Page)

(Example 2 Output Continued)

(Table 7-1-4 Concluded)

Inlet 1 Cross Section 5

Total area (ft²) 60112.00
 Total width (ft) 3744.00

Channel ->	1	2	3	4
Area (ft ²)	22912.5	6873.2	5186.1	25139.6
Width (ft)	1507.7	325.9	155.5	1754.9
Depth (ft)	15.3	24.3	34.0	14.7
Weight	0.2850	0.3649	0.0600	0.2901

X	Discharge (cfs)	Depths (ft)
37.459	0.002	1.982
74.917	0.024	5.946
112.376	0.087	9.810
149.835	0.117	11.006
187.294	0.117	11.006
224.752	0.117	11.006
262.211	0.117	11.006
299.670	0.117	11.006
337.129	0.119	11.087
374.587	0.130	11.427
↓	↓	↓
3633.498	0.090	10.005
3670.956	0.064	8.773
3708.415	0.017	5.225
3745.874	0.020	1.626

Summary of Friction Losses

Section	Friction Loss/ft of Channel Length (dimensionless)
1	43.992
2	2.460
3	14.245
4	3.332
5	35.970

(Example 2 Output Continued)

Plot Output File 2

This file (Table 7-1-5, default name **PLOTDAT2.OUT**) contains a table of velocity hydrographs produced by the simulation at selected flow net cell locations. The velocities (feet per second) are reported at the *Tabular Output Time Interval* and represent the velocity condition at the centers of the selected flow net cells. Figure 7-1-10 is a velocity hydrograph at cell (1,2,2) of the inlet.

Table 7-1-5
Listing of Plot Output File 2 for Example Problem 2

Hour	(1,2,2)	(1,2,1)	(1,2,3)	(1,2,4)
0.50	-6.26	-2.48	-6.39	-1.53
1.00	-5.81	-2.30	-5.93	-1.42
1.50	-4.52	-1.79	-4.61	-1.10
2.00	-2.87	-1.14	-2.93	-0.70
2.50	-0.70	-0.28	-0.72	-0.17
3.00	2.10	0.83	2.14	0.51
3.50	3.22	1.28	3.28	0.79
4.00	3.56	1.42	3.63	0.88
↓	↓	↓	↓	↓
34.50	4.90	1.99	5.00	1.25
35.00	4.85	1.97	4.94	1.24
35.50	4.79	1.95	4.88	1.23
36.00	4.64	1.89	4.74	1.19
36.50	4.49	1.83	4.58	1.16
37.00	4.25	1.74	4.34	1.10
37.50	3.96	1.62	4.04	1.02
38.00	3.57	1.46	3.64	0.92

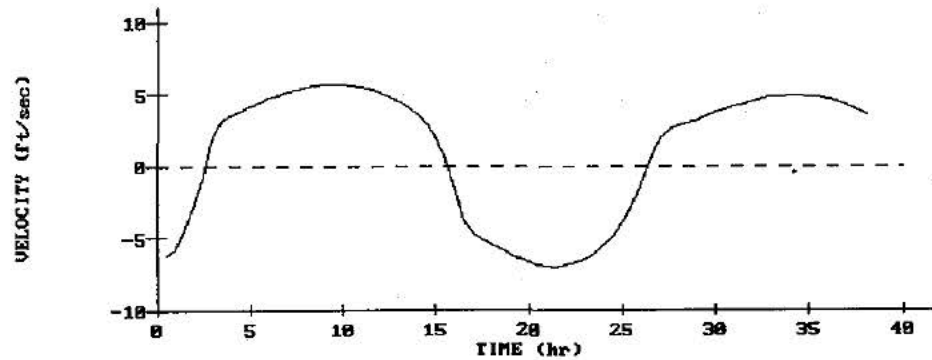

Figure 7-1-10. Velocity Hydrograph at Cell (1,2,2)

(Example 2 Output Continued)

Plot Output File 3

This file contains elevation and discharge hydrographs for the sea boundary conditions, bay, and inlet(s). Results are tabulated at the *Tabular Output Time Interval* and represent summary conditions at the indicated times for the entire system. Included in the file are sea and bay elevations, riverine inflows, average velocity at the controlling cross section, and inlet discharge. Also included in the file is a summary of flood and ebb regimes and volumes identified during the simulation. Table 7-1-6 is a partial listing of data contained in plot output file 3 (default name **PLOTDAT3.OUT**). Figures 7-1-11 through 7-1-13 are hydrograph plots of these parameters.

Table 7-1-6
Partial Listing of Plot Output File 3 for Example Problem 2

Time (hr)	Sea El (ft)	Bay El (ft)	Riverine Inflow (cfs)	Controlling Section Vel (cfs)	Inlet Q (cfs)
0.50	-0.49	-0.08	0.00	-2.83	-121489.60
0.60	-0.49	-0.10	0.00	-2.87	-123317.00
1.00	-0.47	-0.20	0.00	-2.62	-112561.60
1.50	-0.43	-0.30	0.00	-2.04	-87524.16
2.00	-0.37	-0.37	0.00	-1.30	-55659.24
2.50	-0.30	-0.41	0.00	-0.32	-13664.77
2.63	-0.28	-0.41	0.00	0.02	745.18
3.00	-0.22	-0.39	0.00	0.95	40848.79
3.50	-0.12	-0.34	0.00	1.45	62900.23
4.00	-0.02	-0.27	0.00	1.61	69955.90
↓	↓	↓	↓	↓	↓
35.50	1.53	1.10	0.00	2.19	101222.60
36.00	1.60	1.20	0.00	2.12	98549.31
36.50	1.67	1.30	0.00	2.05	95617.21
37.00	1.72	1.39	0.00	1.95	90929.11
37.50	1.76	1.48	0.00	1.81	84919.09
38.00	1.78	1.56	0.00	1.63	76627.07

Inlet 1	Start Time	End Time	Volume (ft ³ x1000)
Ebb	0.03	2.60	-735969.80
Flood	2.63	15.67	4240797.00
Ebb	15.70	26.43	-4078206.00
Flood	26.47	38.50	3528005.00

(Example 2 Output Continued)

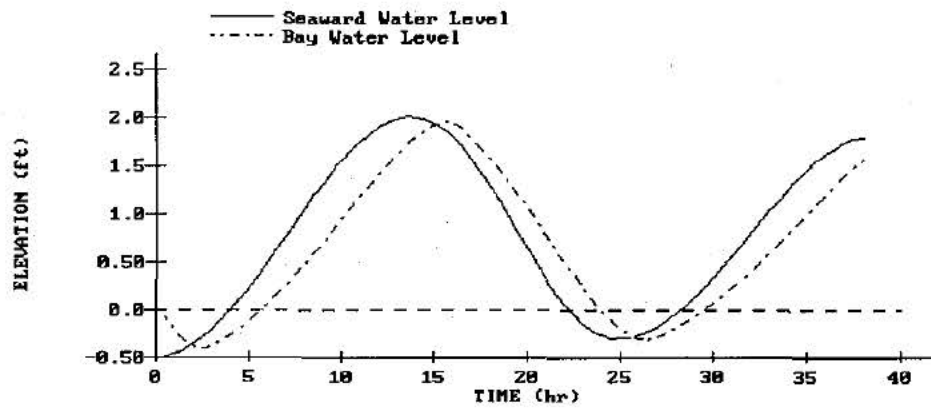

Figure 7-1-11. Sea and Bay Water Elevations at Inlet 1

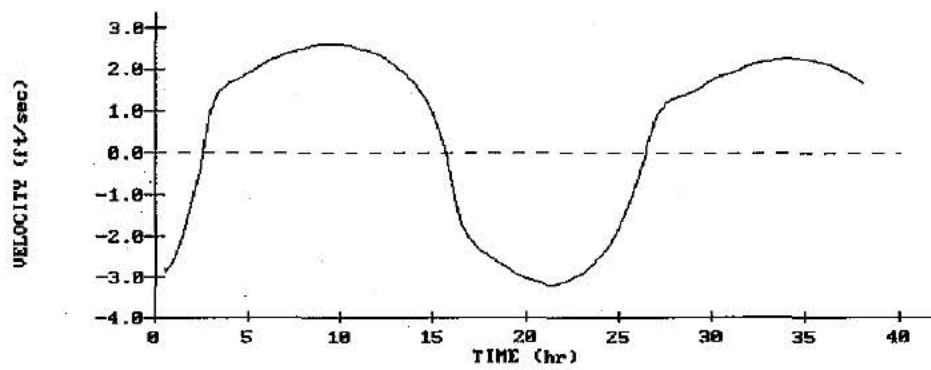

Figure 7-1-12. Average Velocity at Controlling Cross Section

(Example 2 Output Continued)

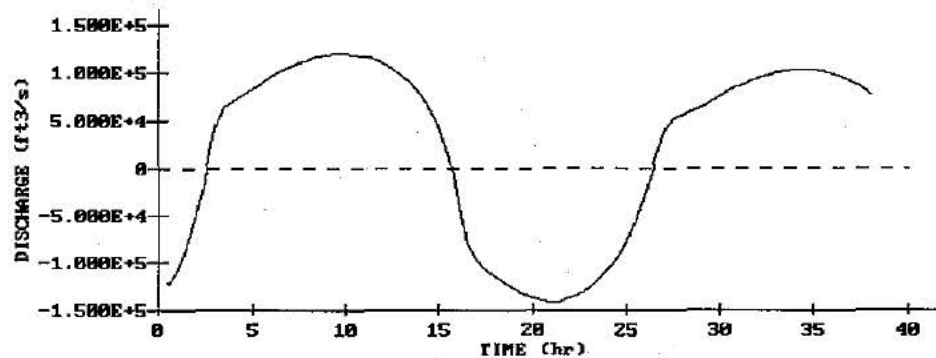

Figure 7-1-13. Inlet Discharge

REFERENCES AND BIBLIOGRAPHY

- Harris, D. L., and Bodine, B. R. 1977. "Comparison of Numerical and Physical Models, Masonboro Inlet, North Carolina," CERC GITI Report 6, US Army Engineer Waterways Experiment Station, Vicksburg, MS.
- International Business Machines. 1970. "System/360 Scientific Subroutine Package, Version II Programmer's Manual," White Plains, NY.
- Keulegan, G. H. 1967. "Tidal Flow in Entrances, Water-Level Fluctuations of Basins in Communication with Seas," Technical Bulletin No. 14, Committee on Tidal Hydraulics, US Army Corps of Engineers, Vicksburg, MS.
- Masch, F. D., Brandes, R. J., and Reagan, J. D. 1977. "Numerical Simulation of Hydrodynamics (WRE)," Appendix 2, CERC GITI Report 6, US Army Engineer Waterways Experiment Station, Vicksburg, MS.
- Seelig, W. N. 1977. "A Simple Computer Model for Evaluating Coastal Inlet Hydraulics," CERC CETA 77-1, US Army Engineer Waterways Experiment Station, Vicksburg, MS.
- Seelig, W. N., Harris, D. L., and Herchenroder, B. E. 1977. "A Spatially Integrated Numerical Model of Inlet Hydraulics," CERC GITI Report 14, US Army Engineer Waterways Experiment Station, Vicksburg, MS.

APPENDICES

The following pages contain the miscellaneous appendices referenced in the main body of the User's Guide. Appendix A consists of various tables of coefficients, grain-size classifications, and tidal constituents. Appendix B describes the target hardware environment and instructions for installing this version of ACES. Appendix C contains instructions for using the graphics options. Appendix D is a table listing the input and output options of the applications in this version of ACES.

APPENDIX A - TABLES

TABLE OF CONTENTS

Table A-1: K_D Values for Use in Determining Armor Unit Weight	A-1
Table A-2: Layer Coefficient and Porosity for Various Armor Units	A-2
Table A-3: Rough Slope Run-Up Coefficients	A-2
Table A-4: Grain-Size Scales (Soil Classification)	A-3
Table A-5: Major Tidal Constituents	A-4
References and Bibliography	A-5

APPENDIX A - TABLES

Table A-1

K _D Values for Use in Determining Armor Unit Weight (Source: EM 1110-2-2904)							
Armor Units	n ⁽²⁾	Placement	Structure Trunk ⁽⁷⁾		Structure Head		
			Breaking Wave	Nonbreaking Wave	Breaking Wave	Nonbreaking Wave	Slope cot θ
Quarystone							
Smooth rounded	2	Random	1.2 ⁽¹⁾	2.4	1.1 ⁽¹⁾	1.9	1.5-3.0 ⁽⁸⁾
Smooth rounded	>3	Random	1.6 ⁽¹⁾	3.2 ⁽¹⁾	1.4 ⁽¹⁾	2.3 ⁽¹⁾	1.5-3.0 ⁽⁸⁾
Rough angular	1	Random ⁽³⁾	--- ⁽³⁾	2.9 ⁽¹⁾	--- ⁽³⁾	2.3 ⁽¹⁾	1.5-3.0 ⁽⁸⁾
Rough angular	2	Random	2.0	4.0	1.9 ⁽¹⁾ 1.6 ⁽¹⁾ 1.3	3.2 2.8 2.3	1.5 2.0 3.0
Rough angular	>3	Random	2.2 ⁽¹⁾	4.5 ⁽¹⁾	2.1 ⁽¹⁾	4.2 ⁽¹⁾	1.5-3.0 ⁽⁸⁾
Rough angular	2	Special ⁽⁴⁾	5.8	7.0	5.3 ⁽¹⁾	6.4	1.5-3.0 ⁽⁸⁾
Parallelepiped ⁽⁹⁾	2	Special	7.0 - 20.0	8.5 - 24.0 ⁽¹⁾	---	---	1.0-3.0
Tetrapod and Quadripod	2	Random	7.0	8.0	5.0 ⁽¹⁾ 4.5 ⁽¹⁾ 3.5 ⁽¹⁾	6.0 5.5 4.0	1.5 2.0 3.0
Tribar	2	Random	9.0 ⁽¹⁾	10.0	8.3 ⁽¹⁾ 7.8 ⁽¹⁾ 6.0	9.0 8.5 6.5	1.5 2.0 3.0
Dolos	2	Random	15.0 ⁽⁶⁾	31.0 ⁽⁶⁾	8.0 ⁽¹⁾ 7.0	16.0 ⁽¹⁾ 14.0 ⁽¹⁾	2.0 ⁽⁵⁾ 3.0
Modified cube	2	Random	6.5 ⁽¹⁾	7.5	---	5.0 ⁽¹⁾	1.5-3.0 ⁽⁸⁾
Hexapod	2	Random	8.0 ⁽¹⁾	9.5	5.0 ⁽¹⁾	7.0 ⁽¹⁾	1.5-3.0 ⁽⁸⁾
Toskane	2	Random	11.0 ⁽¹⁾	22.0	---	---	1.5-3.0 ⁽⁸⁾
Tribar	1	Uniform	12.0	15.0	7.5 ⁽¹⁾	9.5 ⁽¹⁾	1.5-3.0 ⁽⁸⁾
Quarystone - graded angular riprap	-	Random	2.2	2.5	---	---	---

(1) **CAUTION:** These K_D values are unsupported and are provided only for preliminary design.

(2) n is the number of units comprising the thickness of the armor layer.

(3) The use of single layer of quarystone armor units is not recommended for structures subject to breaking waves, and only under special conditions for structures subject to nonbreaking waves. When it is used, the stone should be carefully placed.

(4) Special placement with long axis of stone placed perpendicular to structure face.

(5) Stability of dolosse on slopes steeper than 1 on 2 should be substantiated by site-specific tests.

(6) Refers to no-damage criteria (<5 percent displacement, rocking, etc.); if no rocking (<2 percent) is desired, reduce K_D 50 percent (Zwamborn and Van Niekerk, 1982).

(7) Applicable to slopes ranging from 1 on 1.5 to 1 on 5.

(8) Until more information is available, the use of K_D should be limited to slopes ranging from 1 on 1.5 to 1 on 3. Some armor units tested on a structure head indicate a K_D-slope dependence.

(9) Parallelepiped-shaped stone: long slab-like stone with long dimension approximately three times the shortest dimension (Markie and Davidson, 1979).

Table A-2

Layer Coefficient and Porosity for Various Armor Units (Source: SPM)				
Armor Unit	n	Placement	Layer Coefficient	Porosity %
Quarrystone (smooth)	2	Random	1.02	38
Quarrystone (rough)	2	Random	1.00	37
Quarrystone (rough)	>3	Random	1.00	40
Quarrystone (parallelepiped)	2	Special	-	27
Cube (modified)	2	Random	1.10	47
Tetrapod	2	Random	1.04	50
Quadripod	2	Random	0.95	49
Hexipod	2	Random	1.15	47
Tribar	2	Random	1.02	54
Dolos	2	Random	0.94	56
Toskane	2	Random	1.03	52
Tribar	1	Uniform	1.13	47
Quarrystone	Graded	Random	-	37

Table A-3

Rough Slope Run-Up Coefficients (Source: Smith, 1986)		
Armor Material	a	b
Riprap	0.956	0.398
Rubble (Permeable - No Core)	0.692	0.504
Rubble (2 Layers - Impermeable Core)	0.775	0.361
Modified Cubes	0.950	0.690
Tetrapods	1.010	0.910
Quadripods	0.590	0.350
Hexapods	0.820	0.630
Tribars	1.810	1.570
Dolosse	0.988	0.703

Table A-4

Grain-Size Scales (Soil Classification)								
Unified Soils Classification	ASTM Mesh	PHI	MM	Wentworth Classification				
Cobble		-8.00	256.00	Cobble	G R A V E L			
		-7.00	128.00					
		-6.75	107.60					
		-6.50	90.51					
		-6.25	76.11					
		-6.00	64.00					
		-5.75	53.82					
		-5.50	45.26					
		-5.25	38.06					
		-5.00	32.00					
Coarse Gravel		-4.75	26.91	Pebble	G R A V E L			
		-4.50	22.83					
		-4.25	19.00					
		-4.00	16.00					
		-3.75	13.45					
		-3.50	11.31					
		-3.25	9.51					
		-3.00	8.00					
		-2.75	6.73					
		-2.50	5.68					
Fine Gravel	2.5	-2.25	4.76	Granule	S A N D			
	3	-2.00	4.00					
	3.5	-1.75	3.36					
	4	-1.50	2.83					
	5	-1.25	2.38					
	6	-1.00	2.00					
	7	-0.75	1.68					
	8	-0.50	1.41					
	10	-0.25	1.19					
	12	0.00	1.00					
Coarse	14	0.25	0.84	Very Course	S A N D			
	16	0.50	0.71					
	18	0.75	0.59					
	20	1.00	0.50					
	25	1.25	0.42					
	30	1.50	0.35					
	35	1.75	0.30					
	40	2.00	0.25					
	45	2.25	0.21					
	50	2.50	0.177					
Medium	60	2.75	0.149	Coarse	S A N D			
	70	3.00	0.125					
	80	3.25	0.105					
	100	3.50	0.088					
	120	3.75	0.074					
	140	4.00	0.0625					
	170	4.25	0.0526					
	200	4.50	0.0442					
	230	4.75	0.0372					
	270	5.00	0.0313					
Fine	325	6.00	0.0156	Medium	M U D			
	400	7.00	0.0078					
		8.00	0.0039					
		9.00	0.0020					
		10.00	0.0009					
		12.00	0.0002					
	Silt						Very Fine	M U D
Clay				Silt	M U D			
Clay				Clay	M U D			

Table A-5

Major Tidal Constituents		
Symbol	Constituent Name	Frequency (degrees/hour)
M ₂	Lunar semidiurnal	28.984
S ₂	Principal solar semidiurnal	30.000
N ₂	Larger lunar elliptic semidiurnal	28.439
K ₁	Lunisolar diurnal	15.041
M ₄	Shallow-water overtide of principal lunar	57.968
O ₁	Principal lunar diurnal	13.943
M ₆	Shallow-water overtide of principal lunar	86.952
MK ₃	Shallow-water compound	44.025
S ₄	Shallow-water overtide of principal solar	60.000
MN ₄	Shallow-water compound	57.423
ν ₂	Larger lunar evectional	28.512
S ₆	Shallow-water overtide of principal solar	90.000
μ ₂	Variational	27.968
2N ₂	Lunar elliptic semidiurnal (second order)	27.895
00 ₁	Lunar diurnal (second order)	16.139
λ ₂	Smaller lunar evectional	29.455
S ₁	Solar diurnal	15.000
M ₁	Smaller lunar elliptic diurnal	14.496
J ₁	Smaller lunar elliptic diurnal	15.585
M _m	Lunar monthly	0.544
S _{sa}	Solar semidiurnal	0.082
S _a	Solar annual	0.041
M _{sf}	Lunisolar synodic fortnightly	1.015
M _f	Lunar fortnightly	1.098
ρ ₁	Larger lunar evectional diurnal	13.471
Q ₁	Larger lunar elliptic diurnal	13.398
T ₂	Larger solar elliptic	29.958
R ₂	Smaller solar elliptic	30.041
2Q ₁	Lunar elliptic diurnal (second order)	12.854
P ₁	Solar diurnal	14.958
2SM ₂	Shallow-water compound	31.015
M ₃	Lunar terdiurnal	43.476
L ₂	Smaller lunar elliptic semidiurnal	29.528
2MK ₃	Shallow-water compound	42.927
K ₂	Lunisolar semidiurnal	30.082
M ₈	Shallow-water overtide of principal lunar	115.936
MS ₄	Shallow-water compound	58.984

REFERENCES AND BIBLIOGRAPHY

- Headquarters, Department of the Army. 1986. "Design of Breakwaters and Jetties," Engineer Manual 1110-2-2904, Washington, DC, Chapter 4, p. 10.
- Hobson, R. D. 1977. "Review of Design Elements for Beach Fill Evaluation," Technical Paper 77-6, US Army Engineer Waterways Experiment Station, Vicksburg, MS.
- Krumbein, W. C. 1957. "A Method for Specification of Sand for Beach Fills," Technical Memorandum No. 102, Beach Erosion Board, US Army Engineer Waterways Experiment Station, Vicksburg, MS.
- Markle, D. G., and Davidson, D. D. 1979. "Placed-Stone Stability Tests, Tillamook, Oregon; Hydraulic Model Investigation," Technical Report HL-79-16, US Army Engineer Waterways Experiment Station, Vicksburg, MS.
- Schureman, P. 1971 (reprinted). "Manual of Harmonic Analysis and Prediction of Tides," Coast and Geodetic Survey Special Publication No. 98, Revised (1940) Edition, US Government Printing Office, Washington, DC.
- Shore Protection Manual*. 1984. 4th ed., 2 Vols., US Army Engineer Waterways Experiment Station, Coastal Engineering Research Center, US Government Printing Office, Washington, DC, Chapter 7, pp. 202-242.
- Smith, O. P. 1986. "Cost-Effective Optimization of Rubble-Mound Breakwater Cross Sections," Technical Report CERC-86-2, US Army Engineer Waterways Experiment Station, Vicksburg, MS, p. 48.
- Zwamborn, J. A., and Van Niekerk, M. 1982. *Additional Model Tests--Dolos Packing Density and Effect of Relative Block Density*, CSIR Research Report 554, Council for Scientific and Industrial Research, National Research Institute for Oceanology, Coastal Engineering and Hydraulics Division, Stellenbosch, South Africa.

APPENDIX B - HARDWARE AND INSTALLATION

TABLE OF CONTENTS

Hardware	B-1
Installation	B-2
ACES Software Installation	B-2
Graphics Software Installation	B-4
Example of Graphics Software Installation	B-4

APPENDIX B - HARDWARE AND INSTALLATION

HARDWARE

The Automated Coastal Engineering System (ACES) is designed to run on IBM PC-AT (or compatible) machines having the following configuration:

- 640 Kb memory
- 80287 math co-processor

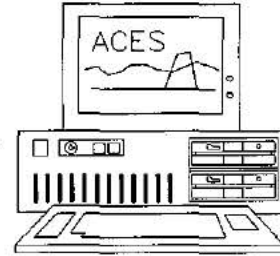

The screen displays in ACES are designed in color. A color adaptor and monitor (VGA, EGA, PGA, or CGA) are preferable. Some monochrome display adaptors and monitors will also work. A printer is preferable, but not required.

Tables B-1 through B-3 list the hardware devices (graphics adaptors, printers, and plotters) that are supported by the graphics software.

Table B-1. Supported Graphics Adaptors (Resolution and Colors)
Color Graphics Adaptor (CGA)
Enhanced Graphics Adaptor (EGA)
Monochrome Display (640 x 350; 4 colors)
Color Display (640 x 200; 16 colors)
Enhanced Color Display (640 x 200; 16 colors)
NEC GB-1 with Multi-Frequency Monitor (640 x 480; 16/64 colors)
EVEREX EVGA with Multi-Frequency Monitor (800 x 600; 16/64 colors)
Video Graphics Adaptor (VGA)
Analog Monitor (640 x 480; 16/256 colors)
Video 7 with Multi-Frequency Analog Monitor (720 x 640; 16/256 colors)
Video 7 with Multi-Frequency Analog Monitor (800 x 600; 16/256 colors)
ORCHID/GENOA with Multi-Frequency Analog Monitor (800 x 600; 16/256 colors)
AST/PARADISE with Multi-Frequency Analog Monitor (800 x 600; 16/256 colors)
Other Graphics Adaptors
Hercules (720 x 348; 2 colors)
COMPAQ Portable III with Gas Plasma Display (640 x 400; 2 colors)

Table B-2. Supported Printers
IBM Graphics
Epson FX/RX Series
HP LaserJet
HP PaintJet

Table B-3. Supported Plotters
HP-Compatible 2-Pen Plotter
HP-Compatible 6-Pen Plotter
HP-Compatible 8-Pen Plotter

INSTALLATION

Installation of this version of ACES requires installing ACES in a specified directory and customizing the graphics setup. The next two sections describe these installation procedures.

ACES Software Installation

The ACES software is distributed on one high-density (1.2-Mb) diskette. To install ACES on a hard disk requires creating a directory where ACES will reside, and de-archiving the files on the ACES diskette to that directory. These steps are detailed below.

1. Use the DOS **MD** or **MKDIR** command to create a subdirectory in which the ACES files will reside. The example below assumes that the subdirectory will be called **ACES107** and will be a subdirectory of the *root* directory on the **C:** drive.

CD C: (go to the root directory)

MD C:\ACES107 **ENTER** (create a new directory called ACES107)

CD \ACES107 **ENTER** (move into the new directory)

2. Insert the ACES disk in Drive A and type:

```
A:PKXARC A:*.ARC 
```

ACES will now be installed in subdirectory ACES107. Refer to the section of Appendix B titled **Graphics Software Installation** for instructions for installing the ACES graphics capability.

3. Any last-minute changes or additions to the ACES Program are documented in a file called **README**. Review this file and make note of any changes. To display the **README** file, type:

```
TYPE README | MORE 
```

4. For ACES to run properly, the configuration file **CONFIG.SYS** must contain the following two statements:

```
FILES=n  
BUFFERS=n
```

where n is greater than or equal to 20. If n is less than 20, edit the **CONFIG.SYS** file and reboot DOS.

5. To run the ACES program, type:

```
ACES 
```

Graphics Software Installation

The graphics capabilities of this version of ACES must be installed with a special program called **INSTALL.COM**. The following section provides an example installation using the program **INSTALL.COM**.

Example of Graphics Software Installation

A typical interactive session for **INSTALL.COM** is described below. Please note that all user responses are highlighted in **boldface type**. Standard default options (inside brackets []) can be selected by pressing **ENTER** from the keyboard. This example installation assumes the following configuration to be installed:

- Enhanced Graphics Adaptor (EGA)
- Resolution (640 x 350)
- Supporting 16 colors
- Plotter Type - HP compatible 8-pen plotter (COM1:)
- Printer Type - Hewlett Packard (HP) Laserjet (LPT1:)

The graphics software may be installed by following these steps (user responses are highlighted in **boldface type**):

1. C:\ACES107> **INSTALL** **ENTER**

2. Enter the code for the display adaptor that matches your system:
- 0) Monochrome Display Adaptor (No graphics)
 - 1) Color Graphics Adaptor (CGA)
 - 2) Enhanced Graphics Adaptor (EGA)
 - 3) Video Graphics Adaptor (VGA)
 - 4) Other

Enter selection [1] **2** **ENTER**

3. Enter the code for the EGA and display monitor that matches your system:

	Resolution and Colors
0) Return to previous menu	
1) Enhanced Graphics Adaptor w/ Monochrome Display	640 x 350 x 4
2) Enhanced Graphics Adaptor w/ Color Display	640 x 200 x 16
3) Enhanced Graphics Adaptor w/ Enhanced Color Display, 64K	640 x 200 x 16
4) Enhanced Graphics Adaptor w/ Enhanced Color Display, >64K	640 x 350 x 16/64
5) NEC GB-1 EGA w/ multi-frequency monitor	640 x 480 x 16/64
6) Everex EVGA w/ multi-frequency monitor	800 x 600 x 16/64

Enter selection [0] 4

4. Select a pen plotter:

- 0) No Plotter
- 1) HP-compatible 2-pen plotter
- 2) HP-compatible 6-pen plotter
- 3) HP-compatible 8-pen plotter

Enter selection [0] 3

5. Select a graphics printer:

- 0) No Printer
- 1) IBM Graphics
- 2) Epson FX/RX Series
- 3) HP LaserJet
- 4) HP PaintJet

Enter selection [1] 3

6. Select plotter port:

1) COM1: 2) COM2: 3) LPT1: 4) LPT2: 5) LPT3:

Enter selection [1] 1

7. Select printer port:

1) LPT1: 2) LPT2: 3) LPT3:

Enter selection [1] 1

Please wait ...

Finished installing ACES.EXE & INSTALL 4.5...21 Nov 1989

NOTE: Before sending graphics to a plotter, be sure to type

MODE COM1:(rate),n,8,1,p

where (rate) is the baud rate to which the plotter is set with
the switches on the rear panel.

APPENDIX C - GRAPHICS OPTIONS

TABLE OF CONTENTS

Introduction	C-1
Main Graphics Options Menu	C-1
Scal	C-2
Grid	C-2
Colr	C-3
Dump	C-3
Styl	C-4
Legn	C-5
Axis	C-6
Read	C-6
Devi	C-7
Wind	C-8
Zero	C-9
Next	C-9
Quit	C-9

APPENDIX C - GRAPHICS OPTIONS

INTRODUCTION

A simple graph often can reveal information that is not immediately apparent in a table. The Automated Coastal Engineering System (ACES) has the capability to instantly create and modify graphs for certain applications. This appendix of the *User's Guide* describes how to create, customize, and print graphs. For installation of the graphics capability, see Appendix B.

MAIN GRAPHICS OPTIONS MENU

For ACES applications providing graphics capabilities, the Main Graphics Options Menu appears at the bottom of the screen below each plot. The current option is highlighted for identification. Options may be accessed by using the \leftarrow and \rightarrow keys from the keyboard. Options may also be accessed by typing the first letter of the option name. The graphics software also supports a mouse (Microsoft Mouse compatible), which can be used as an input device. The main graphics options available are shown in Table C-1. A description of each option (and suboptions) is given in the sections that follow.

Option	Description	Default
Scal	AUTOMATIC or USER-DEFINED SCALING	Automatic
Grid	GRIDAXIS Toggle Switch	tic axis
Colr	Change COLOR of Each Curve	
Dump	SCREEN DUMP to Installed Printer	
Styl	Change LINE & MARKER STYLES of Each Curve	Solid Line
Legn	Relocate the LEGEND	
Axis	AXIS TYPE - Linear/Log	Linear
Read	READ POINTS from the Selected Curve	
Devi	Select OUTPUT DEVICE - Screen, Plotter, HPGL file	Screen
Wind	WINDOW the Current Plot	All
Zero	ZERO LINE DISPLAY Toggle Switch	
Next	NEXT Plot	
Quit	Return to Current ACES Application	

Scal

Automatic (computer-generated) or user-defined scaling may be selected for the current display. Suboptions available under **Scal** are:

(a) **Automatic** - This is the default case. Minimums and maximums are computed for both X and Y from the data selected for plotting. These values (xmin, xmax, ymin, ymax) become the window for the current display.

(b) **User-Defined** - A user-defined scale may be selected. The current minimum and maximum values for both X and Y are displayed (inside parentheses) at the bottom of the screen. These may be changed to new values or selected with a carriage return to accept the current value shown. The revised plot is then displayed.

(c) **Ret** - Program control is returned to the Main Graphics Options Menu.

Grid

This option allows switching (toggling) between *tic* axes (the default) and *grid* generated axes for the plot. Since the default plot uses *tic* axes, the first time this option is selected, *grid* axes will be generated for both the X- and Y-axes. Again selecting this option returns the axis to the default or *tic* axes display.

NOTE: The selected axis type remains in effect for all subsequent plots for a particular application unless changed with this option.

Colr

The color of each curve on the display can be changed. **Colr** options are displayed across the bottom of the screen. Suboptions available under **Colr** are:

(a) - 0,1,2,...,15 - These numbers represent colors supported by this graphics software. The color name for each number is displayed in the lower left corner of the screen just above the numbers.

NOTE: If a color is not supported by the graphics adapter (see Table B-1 in Appendix B), the curve will retain its original color. The color **black** can be used to *blackout* or temporarily delete a particular curve.

(b) - **Plt** - Replot the graph after changes have been made.

(c) - **Ret** - Control is returned to the Main Graphics Options Menu.

The **<-** and **->** keys are used to move the highlighted box to the number representing the desired color. Press **ENTER** to select the highlighted color for the curve. This process can be repeated for the remaining curves on the graph. The suboption **Plt** will replot the graph with the new color selections.

NOTE: The curve that is to be changed is identified in the upper left corner of the screen, and its current color number is highlighted at the bottom of the screen. Press **ENTER** if no change in the curve color is desired.

Dump

A screen image of the current display (without the Main Graphics Options Menu) is sent to the installed printer. Program control is temporarily suspended until printing is completed.

NOTE: If no printer has been installed, a message will be displayed at the bottom of the screen. Press **ENTER** to return to the Main Graphics Options Menu.

Styl

The *Line Styles* and/or *Marker Types* of each curve on the current display can be changed. The suboptions available under **Styl** are displayed across the bottom of the screen. Suboptions are:

(a) Line Styles - 0,1,2,...,6 - These numbers represent the *Line Styles* supported by this graphics software. A *Line Styles* description for each number is displayed in the lower left corner of the screen just above the numbers. The *Line Styles* supported are:

- 0 - No Line (Points Only)
 - 1 - Solid Line (Default)
 - 2 - Long Dashed Line
 - 3 - Dotted Line
 - 4 - Dashed Dotted Line
 - 5 - Medium Dashed Line
 - 6 - Dash Dot Dot Line
- Ret - Program control is returned to the **Styl Options Menu**.

The **<-** and **->** keys are used to move the highlighted box to the desired *Line Styles* number. Press **ENTER** to select the highlighted *Line Style*. This process can be repeated for the remaining curves on the graph. The suboption **Plt** will replot the graph with the new *Line Styles*. The suboption **Ret** will return to the **Styl Options Menu**.

NOTE: The curve that is to be affected by the *Line Styles* change is identified in the upper-left corner of the screen, and its current *Line Style* number is highlighted at the bottom of the screen. Press **ENTER** if no change in the curve *Style* is desired.

(b) Marker Types - 0,1,2,...,6 - These numbers represent the *Marker Types* supported by this graphics software. A *Marker Types* description for each number is displayed in the lower-left corner of the screen just above the numbers. The *Marker Types* supported are:

- 0 - No Marker (Default)
- 1 - Dot

- 2 - Cross
- 3 - Star
- 4 - Square
- 5 - X
- 6 - Diamond

Ret - Program control is returned to the Styl Options Menu.

The \leftarrow and \rightarrow keys are used to move the highlighted box to the desired *Marker Types* number. Pressing **ENTER** will select the highlighted *Marker Types*. This process can be repeated for the remaining curves on the graph. The suboption **Plt** will replot the graph with the new *Marker Types*. The suboption **Ret** will return to the Styl Options Menu.

NOTE: The curve that is to be affected by the *Marker Types* change is identified in the upper-left corner of the screen and its current *Marker Type* number is highlighted at the bottom of the screen. Press **ENTER** if no change in the curve *Marker* is desired.

(c) **Plt** - Replot the graph after changes have been made.

(d) **Ret** - Program control is returned to the Main Graphics Options Menu.

Legn

The legend may be moved to any position on the current display. When this option is selected, cross hairs appear on the screen at the upper-left corner of the legend. The arrow keys may be used to position the cross hairs at a new location. Press **ENTER** to display the revised plot.

NOTE: The new legend position remains in effect for all remaining plots of the current application unless changed with this option.

Axis

This option allows the flexibility of switching to logarithmic or linear coordinate systems for the selected data.

NOTE: If the data contain negative values which cannot be scaled into logarithmic coordinates, a message will appear on the screen stating that no logarithmic axis can be drawn. The resulting plot is then displayed with a linear coordinate system (default).

Suboptions available under Axis are:

- (a) **Lin X-Lin Y** - This is the default case. The coordinate system is linear for both the X- and Y-axes.
 - (b) **Lin X-Log Y** - The coordinate system is linear for the X-axis and logarithmic (base 10) for the Y-axis.
 - (c) **Log X-Lin Y** - The coordinate system is logarithmic (base 10) for the X-axis and linear for the Y-axis.
 - (d) **Log X-Log Y** - The coordinate system is logarithmic (base 10) for both the X- and Y-axes.
 - (e) **Ret** - Program Control is returned to the Main Graphics Options Menu.
-

Read

This option displays the estimated y value for a corresponding x value for each curve. At the prompt, an x value is entered that is bounded by the window of the current display ($x_{\min} < x < x_{\max}$). The estimated y value is displayed at the bottom of the screen. Each selected (x,y) pair is marked on its corresponding curve by an x . Press **ENTER** to return program control to the Main Graphics Option Menu.

NOTE: If an x value that is not inside the window of the current display is selected, a message is displayed at the bottom of the screen stating that the entered x value is out of range. Press **ENTER** to re-display the plot and return to the Main Graphics Options Menu.

Devi

This option selects a specific output device to which the current display will be sent. Suboptions available under **Devi** are:

(a) **Screen** - This is the default case. The selected plot will be displayed on the installed graphics display.

(b) **Plotter** - The plot will be sent to the installed plotter.

NOTE: Program control is suspended until the plotter has stopped. If no plotter has been installed, a message will be displayed requesting that the **INSTALL** program be run to configure the proper hardware setup. The ACES program will be terminated, and control will be returned to the DOS prompt.

(c) **Plot File** - The plot will be sent to a plot file for processing at a later time. The plot file is named xxxx.PLT, where xxxx is a 4-digit number beginning with 0000. Any subsequent plots sent to this device are named 0001.PLT, 0002.PLT, etc. These plot files are HP compatible *only* and can be postprocessed upon completion of the ACES interactive session. These files can be copied to the appropriate communication port where the plotter is connected to generate the plots. For example, to copy plot file 0001.PLT to the plotter that is connected to communication port 2 (COM2:), the following is entered at the DOS prompt:

```
C:\ACES105> COPY 0001.PLT COM2: 
```

NOTE: The communication port must be set to coincide with the plotter's baud rate, parity, and stop bit settings for correct use. (Third party software is available that will translate these plot files to an HP-compatible LaserJet Series printer.)

(d) **Ret** - Program Control is returned to the Main Graphics Options Menu.

Wind

This option specifies the boundaries and size of the current display. Suboptions available under **Wind** are:

(a) **All** - This is the default case. The original plot will be displayed. If **User-Defined** scaling is selected (see **Scal** options described above), this becomes the default during this option.

(b) **Window** - This option zooms in or out on a particular subregion of the current display by locating two opposite corners of a window enclosing the desired region. When this suboption is selected, crosshairs are displayed in the middle of the screen. The arrow keys are used to re-locate the crosshairs to one corner of the desired window. Press **ENTER** to lock in this position. The opposite corner of the window is similarly located, and the new region is shown bordered in a box. Press **ENTER** to display only the area delimited by the window.

(c) **Scale** - A scale factor can be entered to enlarge or shrink the existing window in both the X- and Y-directions. For example, a scale factor of 0.5 doubles the window in both the X- and Y-directions. The resulting plot contains the same data mapped into a larger window and gives the effect of *zooming out* on the selected data. Conversely, *zooming in* is achieved by entering a scale factor greater than 1.

NOTE: The scale factor entered is applied to both the X- and Y-coordinate system resulting in:

$$X_{min} = X_{min} / \text{factor}$$

$$X_{max} = X_{max} / \text{factor}$$

$$Y_{min} = Y_{min} / \text{factor}$$

$$Y_{max} = Y_{max} / \text{factor}$$

(d) **Ret** - Program control is returned to the Main Graphics Options Menu.

Zero

This option switches the optional display of a zero line ($y=0.0$) on the plot. The zero line contains the following two coordinates: (xmin, 0.0) and (xmax, 0.0).

NOTE: If the zero line is displayed on the plot, selecting this option will remove it. Selecting it again will re-display the zero line.

Next

This option displays the next plot in the series.

NOTE: Some applications in ACES have multiple plots. If the current application has only one plot and this option is selected, the screen is erased and the user is returned to the current ACES application.

Quit

This option terminates all graphics options. The screen is erased, and program control is returned to the current ACES application.

APPENDIX D - INPUT/OUTPUT OPTIONS

Applications	Input				Output											
	Screen		File		Screen		Printer		Plots		Plot Output Files					
											1		2		3	
	S	M	S	M	S	M	S	M	S	M	S	M	S	M	S	M
1. Wave Prediction																
1-1	Windspeed Adjustment and Wave Growth															
	D	D	-	-	D	-	O	D	-	-	-	-	-	-	-	-
1-2	Beta-Rayleigh Distribution															
	D	D	-	-	D	-	O	D	O	-	O	-	-	-	-	-
1-3	Extremal Significant Wave Height Analysis															
	O	-	O	-	O	-	O	-	O	-	D	-	-	-	-	-
1-4	Constituent Tide Record Generation															
	O	-	O	-	-	-	-	O	-	O	-	-	-	-	-	-
2. Wave Theory																
2-1	Linear Wave Theory															
	D	D	-	-	D	-	O	D	-	-	-	-	-	-	-	-
2-2	Cnoidal Wave Theory															
	D	D	-	-	D	-	O	D	O	-	O	-	-	-	-	-
2-3	Fourier Series Wave Theory															
	D	-	-	-	D	-	O	-	O	-	O	-	-	-	-	-
3. Wave Transformation																
3-1	Linear Wave Theory with Snell's Law															
	D	D	-	-	D	-	O	D	-	-	-	-	-	-	-	-
3-2	Irregular Wave Transformation (Goda's Method)															
	D	D	-	-	D	-	O	D	O	-	O	-	-	-	-	-
3-3	Combined Diffraction and Reflection by a Vertical Wedge															
	D	D	-	-	D	-	O	D	-	-	D	-	-	-	-	-
4. Structural Design																
4-1	Breakwater Design Using Hudson and Related Equations															
	D	D	-	-	D	-	O	D	-	-	-	-	-	-	-	-
4-2	Toe Protection Design															
	D	D	-	-	D	-	O	D	-	-	-	-	-	-	-	-
4-3	Nonbreaking Wave Forces on Vertical Walls															
	D	D	-	-	D	-	O	D	O	-	O	-	-	-	-	-
4-4	Rubble-Mound Revetment Design															
	D	D	-	-	D	-	O	D	-	-	-	-	-	-	-	-
5. Wave Runup, Transmission, and Overtopping																
5-1	Irregular Wave Runup on Beaches															
	D	D	-	-	D	-	O	D	-	-	-	-	-	-	-	-
5-2	Wave Runup and Overtopping on Impermeable Structures															
	D	D	-	-	D	-	O	D	-	-	-	-	-	-	-	-
5-3	Wave Transmission on Impermeable Structures															
	D	D	-	-	D	-	O	D	-	-	-	-	-	-	-	-
5-4	Wave Transmission Through Permeable Structures															
	D	D	-	-	D	-	O	D	-	-	-	-	-	-	-	-
6. Littoral Processes																
6-1	Longshore Sediment Transport															
	D	D	-	-	D	-	O	D	-	-	-	-	-	-	-	-
6-2	Numerical Simulation of Time-Dependent Beach and Dune Erosion															
	O	-	O	-	-	-	-	O	-	O	-	O	-	-	-	-
6-3	Calculation of Composite Grain-Size Distribution															
	O	-	O	-	O	-	-	O	-	D	-	-	-	-	-	-
6-4	Beach Nourishment Overfill Ratio and Volume															
	D	-	-	-	D	-	O	-	-	-	-	-	-	-	-	-
7. Inlet Processes																
7-1	A Spatially Integrated Numerical Model of Inlet Hydraulics															
	O	-	O	-	-	-	-	O	-	D	-	D	-	D	-	-

NOTE:
Symbols are defined as follows:

S - Single Case Mode
M - Multiple Case Mode

D - Default
O - Optional
- - Unavailable

REPORT DOCUMENTATION PAGE

Form Approved
OMB No. 0704-0188

Public reporting burden for this collection of information is estimated to average 1 hour per response, including the time for reviewing instructions, searching existing data sources, gathering and maintaining the data needed, and completing and reviewing the collection of information. Send comments regarding this burden estimate or any other aspect of this collection of information, including suggestions for reducing this burden, to Washington Headquarters Services, Directorate for Information Operations and Reports, 1215 Jefferson Davis Highway, Suite 1204, Arlington, VA 22202-4302, and to the Office of Management and Budget, Paperwork Reduction Project (0704-0188), Washington, DC 20503.

1. AGENCY USE ONLY (Leave blank)	2. REPORT DATE September 1992	3. REPORT TYPE AND DATES COVERED Final report	
4. TITLE AND SUBTITLE Automated Coastal Engineering System: User's Guide		5. FUNDING NUMBERS	
6. AUTHOR(S) David A. Leenknecht, Andre Szuwalski, Ann R. Sherlock		8. PERFORMING ORGANIZATION REPORT NUMBER	
7. PERFORMING ORGANIZATION NAME(S) AND ADDRESS(ES) USAE Waterways Experiment Station Coastal Engineering Research Center 3909 Halls Ferry Road Vicksburg, MS 39180-6199		10. SPONSORING/MONITORING AGENCY REPORT NUMBER	
9. SPONSORING/MONITORING AGENCY NAME(S) AND ADDRESS(ES) US Army Corps of Engineers Washington, DC 20314-1000		11. SUPPLEMENTARY NOTES Available from National Technical Information Service, 5285 Port Royal Road, Springfield, VA 22161.	
12a. DISTRIBUTION/AVAILABILITY STATEMENT Approved for public release; distribution is unlimited.		12b. DISTRIBUTION CODE	
13. ABSTRACT (Maximum 200 words) The Automated Coastal Engineering System (ACES) is an interactive computer-based design and analysis system in the field of coastal engineering. The general goal of the ACES is to provide state-of-the-art computer-based tools that will increase the accuracy, reliability, and cost-effectiveness of Corps coastal engineering endeavors. Reflecting the nature of coastal engineering, methodologies (called "applications" in this guide) contained in this release of the ACES are richly diverse in sophistication and origin. The contents range from simple algebraic expressions, both theoretical and empirical in origin, to numerically intense algorithms spawned by the increasing power and affordability of computers. Historically, the methods range from classical theory describing wave motion, to expressions resulting from tests of structures in wave flumes, and to recent numerical models describing the exchange of energy from the atmosphere to the sea surface. <p style="text-align: right;">(Continued)</p>			
14. SUBJECT TERMS ACES Automated Coastal Engineering System		15. NUMBER OF PAGES 372	
		16. PRICE CODE	
17. SECURITY CLASSIFICATION OF REPORT UNCLASSIFIED	18. SECURITY CLASSIFICATION OF THIS PAGE UNCLASSIFIED	19. SECURITY CLASSIFICATION OF ABSTRACT	20. LIMITATION OF ABSTRACT

19. (Concluded).

In a general procedural sense, much has been taken from previous individual programs on both mainframes and microcomputers. The ACES is designed for a current base of PC-AT (including compatibles) class of personal computers resident at many Corps coastal offices. While expected to migrate to more powerful hardware technologies, this current generation of ACES is designed for the above environment and is written in FORTRAN 77.

The documentation set for the ACES comprises two manuals: User's Guide and Technical Reference. The User's Guide contains instructions for using the individual applications within the ACES software package. The Technical Reference contains theory and discussion of the various methodologies contained in the ACES.