

LOW-JITTER, HIGH-VOLTAGE, INFRARED, LASER-TRIGGERED,  
VACUUM SWITCH

L. M. Earley and G. A. Barnes  
Los Alamos National Laboratory  
P.O. Box 1663  
Los Alamos, New Mexico 87545

Abstract

A laser-triggered, high-voltage vacuum switch using a triggering pellet embedded in the cathode has been developed. The switch was constructed with tungsten electrodes and used either KCl or Poco graphite pellets. An aperture in the anode allowed the laser beam to strike the pellet on the cathode surface. Reliable triggering was achieved with only 200  $\mu$ J of laser energy at a wavelength of 1064 nm. The switch was operated with an A-K gap voltage ranging from 5- to 30-kV with switching currents up to 15 kA peak. The delay time of the switch varied from  $70 \pm 3$  ns at 25 kV to  $500 \pm 100$  ns at 5 kV.

Introduction

A laser-triggered, high-voltage vacuum switch using a triggering pellet embedded in the cathode has been developed for use at voltages comparable to thyratrons. Previous work on a similar switch [1,2] operating at lower voltages was used as the base design. The present work extends the technology from 3- kV to 30-kV. In the present work both KCl and graphite pellets were tested, whereas in the previous work only KCl was used. The motivation to develop this laser-triggered switch was the ability to trigger with low-energy (100  $\mu$ J) laser pulses at a wavelength of 1064 nm. Fiber-optic triggering is very practical for low-energy infrared light. A large body of work has been published on the Back Lighted Thyatron (BLT) with many impressive results [3-5]. However, low jitter BLT triggering has been achieved with ultraviolet (uv) lasers at energy levels of mJ. The BLT switches operate more efficiently at shorter wavelengths but fibers are less efficient at shorter wavelengths. Practical fiber-optic triggering is difficult for these uv levels. The laser-triggered vacuum switch allows a simpler fiber optic triggering system to be developed. Gordon Scott [6] at Sandia National Laboratories has triggered a 3-kV vacuum switch with 1-ns jitter using 1 km of fiber with only 200  $\mu$ J injected into the fiber at a wavelength of 1064 nm. The vacuum switch, however, does not have the long pulse life ( $>10^7$ ) that BLT switches exhibit. A vacuum arc is far more destructive to the electrodes than a low-pressure glow discharge.

The firing characteristics of the vacuum switch measured in this investigation were:

1. Static breakdown voltage.
2. Minimum operating voltage.
3. Laser energy threshold vs voltage.
4. Switch delay time vs voltage.
5. Switch delay time vs laser energy.
6. Jitter vs voltage.
7. Jitter vs laser energy.

Work performed under the auspices of the U.S. Department of Energy.

Experimental Apparatus

Figure 1 shows a cross-sectional drawing of the laser-triggered switch. The switch was constructed with tungsten electrodes, which were taken from a standard Maxwell (Model 40065) 100-kV spark gap. A 0.3-cm-diam aperture in the anode allowed the laser beam to strike the cathode. A 0.3-cm-diam hole in the cathode held either the KCl or carbon pellets. The thickness of the pellets was also 0.3 cm. The switch was operated with an A-K gap of 0.5 cm. Both the anode and cathode were 1.5-cm-diam with full radius. A biconvex lens with a 2.54-cm focal length was used to focus the laser beam to a 0.015-cm-diam spot on the surface of the pellet. The chamber used in this experiment was evacuated using two 100 l/s Varian Vacuon pumps. The typical vacuum level for this experiment was  $5 \times 10^{-8}$  torr. All components were suspended from the cover of the vacuum chamber. Shown in Fig. 1 are the high-voltage vacuum feedthrough, charging inductor, capacitors, switch plates, focusing lens, and the Lucite insulating support rods. Figure 2 shows a cross-sectional view of the switch gap region.

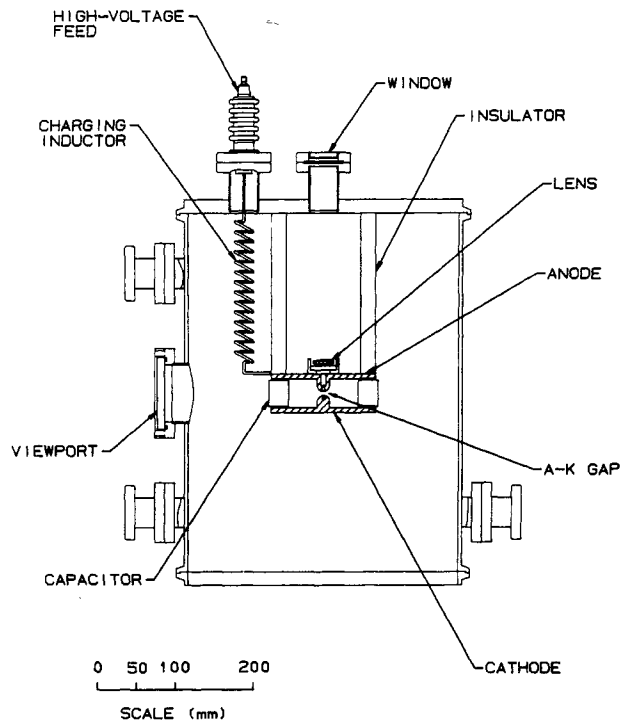

Fig. 1. Laser-triggered switch.

Reliable triggering was achieved with only 200  $\mu$ J ( $1.2 \text{ J/cm}^2$ ) of laser energy at a wavelength of 1064 nm using a Nd:YAG laser (Laser Photonics Model MYL-100). The maximum laser output was 15 mJ in a pulse width of 8 ns. Figure 3 shows a drawing of the optical setup. The pulse energy was varied by adjusting a CVI Laser Corp., continuously variable, high-power attenuator placed after the laser output. The diameter of the focused beam spot on the cathode was adjusted by moving the position of the 2.54-cm focal-length lens. The energy density of the spot could be varied by either

## Report Documentation Page

*Form Approved*  
*OMB No. 0704-0188*

Public reporting burden for the collection of information is estimated to average 1 hour per response, including the time for reviewing instructions, searching existing data sources, gathering and maintaining the data needed, and completing and reviewing the collection of information. Send comments regarding this burden estimate or any other aspect of this collection of information, including suggestions for reducing this burden, to Washington Headquarters Services, Directorate for Information Operations and Reports, 1215 Jefferson Davis Highway, Suite 1204, Arlington VA 22202-4302. Respondents should be aware that notwithstanding any other provision of law, no person shall be subject to a penalty for failing to comply with a collection of information if it does not display a currently valid OMB control number.

1. REPORT DATE <b>JUN 1991</b>	2. REPORT TYPE <b>N/A</b>	3. DATES COVERED <b>-</b>	
4. TITLE AND SUBTITLE <b>Low-Jitter, High-Voltage, Infrared, Laser-Triggered, Vacuum Switch</b>		5a. CONTRACT NUMBER	
		5b. GRANT NUMBER	
		5c. PROGRAM ELEMENT NUMBER	
6. AUTHOR(S)		5d. PROJECT NUMBER	
		5e. TASK NUMBER	
		5f. WORK UNIT NUMBER	
7. PERFORMING ORGANIZATION NAME(S) AND ADDRESS(ES) <b>Los Alamos National Laboratory P. O. Box 1663 Los Alamos, New Mexico 87545</b>		8. PERFORMING ORGANIZATION REPORT NUMBER	
9. SPONSORING/MONITORING AGENCY NAME(S) AND ADDRESS(ES)		10. SPONSOR/MONITOR'S ACRONYM(S)	
		11. SPONSOR/MONITOR'S REPORT NUMBER(S)	
12. DISTRIBUTION/AVAILABILITY STATEMENT <b>Approved for public release, distribution unlimited</b>			
13. SUPPLEMENTARY NOTES <b>See also ADM002371. 2013 IEEE Pulsed Power Conference, Digest of Technical Papers 1976-2013, and Abstracts of the 2013 IEEE International Conference on Plasma Science. Held in San Francisco, CA on 16-21 June 2013. U.S. Government or Federal Purpose Rights License</b>			
14. ABSTRACT <b>A laser-triggered, high-voltage vacuum switch using a triggering pellet embedded in the cathode has been developed. The switch was constructed with tungsten electrodes and used either KCl or Poco graphite pellets. An aperture in the anode allowed the laser beam to strike the pellet on the cathode surface. Reliable triggering was achieved with only 200 ~J of laser energy at a wavelength of 1064 nm. The switch was operated with an A-K gap val tage ranging from 5- to 30-kV with switching currents up to 15 kA peak. The delay time of the switch varied from 70 <math>\hat{A}</math>± 3 ns at 25 kV to 500 <math>\hat{A}</math>± 100 ns at 5 kV.</b>			
15. SUBJECT TERMS			
16. SECURITY CLASSIFICATION OF:			17. LIMITATION OF ABSTRACT <b>SAR</b>
a. REPORT <b>unclassified</b>	b. ABSTRACT <b>unclassified</b>	c. THIS PAGE <b>unclassified</b>	
			18. NUMBER OF PAGES <b>4</b>
			19a. NAME OF RESPONSIBLE PERSON

changing the laser energy or the spot diameter. The energy was measured each pulse with a Laser Precision RJ-7620 Energy Meter. The approximate spot diameter was measured using the burn pattern on a piece of Polaroid film placed on the cathode surface while the test chamber was at atmospheric pressure.

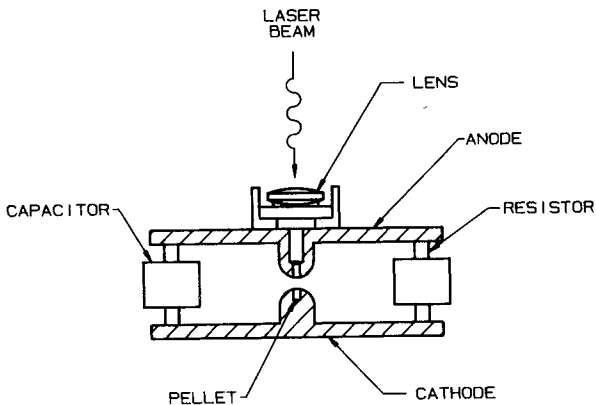

Fig. 2. Switch gap cross-sectional view.

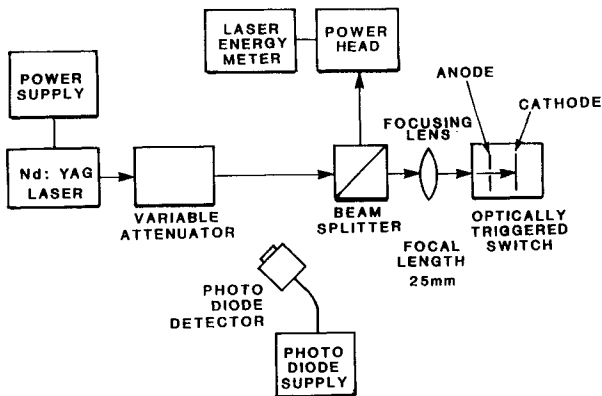

Fig. 3. Experimental optical setup.

Figure 4 shows the test circuit used to evaluate the switch performance. The circuit was a simple RLC discharge circuit where the inductance was kept to a minimum (20 nH). Three TDK 2-nF ceramic capacitors were connected in parallel and dc charged from 5- to 30-kV. To allow large peak currents to flow in the switch a small load resistor of approximately 0.1  $\Omega$  was used. The resistor was fabricated from graphite and was used for the connections between the capacitors and the metal electrode plates. The diagnostics included a high-voltage probe monitoring the charge voltage, an E-dot probe monitoring the anode voltage, and a B-dot probe monitoring the switch current.

#### Experimental Results

The measured static breakdown voltage of the switch was 35 kV. The switch was tested from 5- to 30-kV. The switch operated in a low-jitter mode for voltages above 20 kV. A large portion of the experiments was performed for an anode voltage of 25 kV, or 70% of the self-breakdown voltage. The minimum operating voltage for the switch at any laser power was 4 kV, which corresponds to an electric field in the gap of 8 kV/cm.

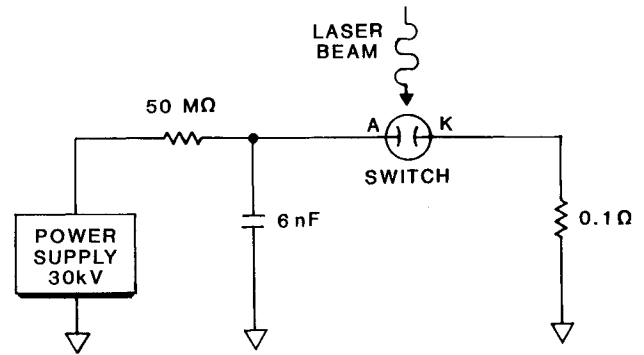

Fig. 4. Switch evaluation circuit.

The laser energy threshold for switch triggering was 50  $\mu\text{J}$  with a focused laser spot diameter at the cathode of 0.015<sub>2</sub> cm. This corresponds to an energy density of 0.3 J/cm<sup>2</sup> and a peak power density of 35 MW/cm<sup>2</sup>. This threshold energy was measured for an A-K gap voltage of 25 kV. The laser energy threshold for triggering at 5 kV was 300  $\mu\text{J}$  and at 4 kV was 400  $\mu\text{J}$ .

The delay time for this switch was defined as the time starting from the 50% point of the laser pulse measured with a photodiode to the 10% point of current flow measured with the B-dot probe. The switch jitter was defined as the variation in the delay time. The delay time was measured for an A-K gap voltage of 25 kV for laser energy of 200-, 500-, 1000-, and 1500- $\mu\text{J}$ . Approximately 100 shots were taken at each laser energy. The waveforms were measured first with a Tektronix 7903 scope with polaroid film. The photodiode measured the laser pulse and the B-dot measured the output switch current pulse. The scope was placed in add mode to superimpose the two signals from which the delay time was measured. The test was automated for the 100-pulse test by using a Tektronix 2440 dual-channel digital scope with their 2402 computer control. The 2440 scope has an analog bandwidth of 350 MHz and a digitizing rate of 500MS/s. The waveforms were then transferred to hard disk on the 2402 controller. In this way multiple waveforms could be overlaid in a post-process mode using the Tektronix software Waveview. The jitter could then be measured from the overlay. In the manual mode the 2440 scope has internal time delay measurement capability. Table I shows a summary of the delay time and jitter vs the laser energy for the switch using a graphite trigger pellet.

Table I  
Delay Time and Jitter vs Laser Energy  
for an A-K Gap Voltage of 25 kV

Energy ( $\mu\text{J}$ )	Time (ns)	Jitter (ns)
50	700	20
100	400	10
200	150	5
500	100	3
1000	80	2
1500	70	2

A direct comparison was made between the graphite trigger pellet and the KCl trigger pellet. Both materials produced nearly identical results; however, the graphite pellets produced lower delay times and jitters for the same energy levels than the KCl pellet. For example, in Table I, for the case of 200  $\mu\text{J}$  of laser energy, the KCl pellet would produce a delay of 250 ns with a 10 ns jitter of 8 ns. However, the delay time and jitter decrease in a fashion similar to the graphite pellet by increasing the laser energy.

## Discussion

Figure 5 shows an output current waveform measured with the B-dot and hardware integrated with a 50- $\Omega$ , 1- $\mu$ s time constant integrator having a bandwidth greater than 500 MHz. The waveform shows the underdamped response of the circuit. The "T" on the baseline prior to current flow is a timing mark indicating where the laser pulse fired. This waveform was taken with a gap voltage of 25 kV and a laser energy of 1000  $\mu$ J. The response of the circuit shows a total circuit and switch inductance of 20 nH. The delay time of switch was approximately 70 ns. Figure 6 shows the leading edge of the integrated B-dot signal for eight consecutive pulses. The switch and laser settings were 25 kV and 1000  $\mu$ J. The digitizing scope was triggered by the laser for each pulse so the jitter between the eight pulses can be read directly from the figure. The indicated jitter is 5 ns. The laser internal jitter, determined by the Q-switch, was less than 1 ns.

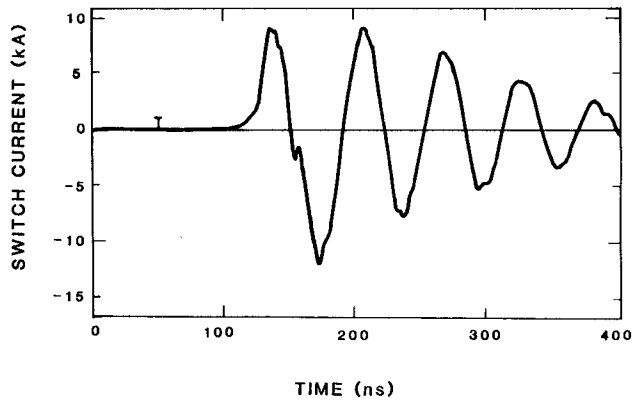

Fig. 5. Switch current measured with an integrated B-dot probe.

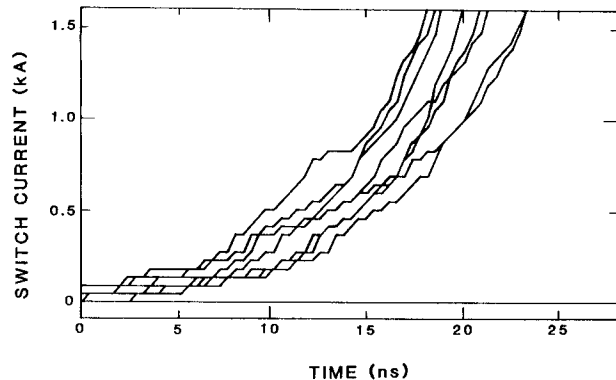

Fig. 6. Eight-pulse overlay of the leading edge of the switch current.

Several thousand pulses were studied during the experimental investigation, with the majority of the tests performed using the graphite pellets. Many different pellets of both types were tested and repeatable results were achieved. The graphite pellets consistently performed with shorter delay times and lower jitters. Erosion of the pellets was minor for laser energies near 200  $\mu$ J, but, serious erosion was observed for energies above 1000  $\mu$ J after several hundred pulses. The erosion consisted of a single crater drilled into the pellet by the laser beam. The switch arc consistently struck the tungsten electrode. Examination of the cathode showed a uniform discoloration of the tungsten around the pellet located in the center of the cathode. The switch delay remained steady even after serious damage occurred to the pellet.

A comparison of the firing characteristics of the present switch (30 kV, 0.5 cm gap) with the lower-voltage (3 kV, 0.05 cm gap) version [2] used as the base design for the present work is given in Table II.

Table II

Characteristic	3 kV Switch	30 kV Switch
A-K Gap	0.05 cm	0.5 cm
Min. Operating Voltage	400 V	4 kV
Self Breakdown Voltage	4.5 kV	35 kV
Electric Field Threshold	8 kV/cm	8 kV/cm
Min. Triggering Energy	10 $\mu$ J	50 $\mu$ J
Laser Spot Diameter	0.015 cm	0.015 cm
Min. Laser Energy Density	0.06 J/cm <sup>2</sup>	0.3 J/cm <sup>2</sup>

In both cases the laser spot diameter used in the experiments was 0.015 cm, and the minimum electric field in the gap required for operation was 8 kV/cm. The present switch (0.5-cm gap) required ten times the laser energy to fire as the 3-kV switch. In both cases the same spot diameter was used. However, the 30-kV switch required ten times the laser energy density to operate. One major difference in the experimental setups was the quality of the vacuum. The 3-kV switch was a metal-ceramic tube that was baked out at 400°C and had an internal vacuum of  $10^{-9}$  torr. The 30-kV switch was not baked out and had an internal vacuum of  $10^{-6}$  torr. One possible explanation for the difference in trigger energy for operation could have been the surface condition of the cathodes and pellets.

The 3-kV switch was also tested at Sandia National Laboratories [6] with a graphite triggering pellet. However, the laser triggering energy threshold was the same for KCl or graphite for the 3 kV switch. Graphite showed a lower energy triggering threshold in the 30-kV switch.

Recent data [6] indicate that a triggering pellet composed of a mixture of graphite and CsI in a 3-kV vacuum switch reliably triggered at a laser energy of less than 1  $\mu$ J for a wavelength of 1064 nm. This new data suggests that a 30 kV vacuum switch that triggers at an energy below 200  $\mu$ J should be reliable with low jitter. Thus, the pellet erosion problem caused by large laser energies could be solved, eliminating this basic drawback of the laser-triggered vacuum switch. Future experiments on a 30-kV vacuum switch with a composite pellet of graphite and CsI should concentrate on pellet erosion and switch pulse life.

#### References

- [1] P. J. Brannon and D. F. Cowgill, "Low- Jitter Laser-Triggered Vacuum Switch Using a Composite Target", IEEE Trans. Plasma Sci., Vol. 16, pp. 325-327, April 1988.
- [2] L. M. Earley and G. L. Scott, "Firing Characteristics of a Low-Jitter miniature Laser-Triggered Vacuum Switch", IEEE Trans. Plasma Sci., Vol. 18, pp. 247- 249, April 1990.
- [3] K. Frank, E. Boggasch, J. Christiansen, A. Goertler, W. Hartmann, C. Kozlik, G. Kirkman, C. Braun, V. Dominic, M. A. Gundersen, H. Riege, and G. Mechttersheimer, "High-Power Pseudospark and BLT Switches", IEEE Trans. Plasma Sci., Vol. 16, pp. 317-323, April 1988.
- [4] C. Braun, W. Hartmann, V. Dominic, G. Kirkman, M. Gundersen, and G. McDuff, "Fiber-Optic-Triggered High-Power Low- Pressure Glow Discharge Switches", IEEE Trans. Electron Devices, Vol. 35, pp.559- 562, April 1988.
- [5] M. C. McKinley and W. C. Nunnally, "UV Triggering of Remote BLTs Using Optical Fibers, and Neodymium:Glass, Neodymium:YAG, and Copper Vapor Lasers",
- [6] Gordon Scott, Division 2565, Sandia National Laboratories, Private Communication.