

# PRINCIPAL CONSIDERATIONS IN LARGE ENERGY-STORAGE CAPACITOR BANKS

by

E. L. Kemp  
Los Alamos Scientific Laboratory  
Los Alamos, New Mexico 87545

## ABSTRACT

Capacitor banks storing one or more megajoules and costing more than one million dollars have unique problems not often found in smaller systems. Two large banks, Scyllac at Los Alamos and Shiva at Livermore, are used as models of large, complex systems. Scyllac is a 10-MJ, 60-kV theta-pinch system while Shiva is a 20-MJ, 20-kV energy system for laser flash lamps.

A number of design principles are emphasized for expediting the design and construction of large banks.

The sensitive features of the charge system, the storage system layout, the switching system, the transmission system, and the design of the principal bank components are presented.

Project management and planning must involve a PERT chart with certain common features for all the activities. The importance of the budget is emphasized.

## Introduction

The capacitor bank is the most universal system for producing the pulse power requirements for several types of fusion experiments. Large capacitor banks, here defined as banks storing more than 1 MJ and costing more than one million dollars, require special attention because of their cost and complexity.

Three of the most important factors in the design and construction of large banks are performance, cost, and reliability. Performance is essential and obviously most important. Cost can be a determinant, but is more subtle and may become a critical issue after the project is well under way. Reliability is a necessary and worthy objective, but it can jeopardize both performance and cost if it is given too much priority. The appropriate balancing of performance, cost, and reliability requires considerable attention and mature judgement.

Two capacitor banks, Scyllac at the Los Alamos Scientific Laboratory<sup>1</sup> and Shiva at the Lawrence Livermore Laboratory,<sup>2</sup> will be used to illustrate certain characteristics of large systems. Scyllac, shown in Fig. 1 during construction, is a 60-kV, 10-MJ toroidal theta-pinch experiment. The bank was built in 1970 for 60 cents per joule. The Shiva system, shown in Fig. 2, is a 20-kV, 20-MJ laser fusion experiment. This

## Report Documentation Page

*Form Approved*  
*OMB No. 0704-0188*

Public reporting burden for the collection of information is estimated to average 1 hour per response, including the time for reviewing instructions, searching existing data sources, gathering and maintaining the data needed, and completing and reviewing the collection of information. Send comments regarding this burden estimate or any other aspect of this collection of information, including suggestions for reducing this burden, to Washington Headquarters Services, Directorate for Information Operations and Reports, 1215 Jefferson Davis Highway, Suite 1204, Arlington VA 22202-4302. Respondents should be aware that notwithstanding any other provision of law, no person shall be subject to a penalty for failing to comply with a collection of information if it does not display a currently valid OMB control number.

1. REPORT DATE <b>NOV 1976</b>	2. REPORT TYPE <b>N/A</b>	3. DATES COVERED <b>-</b>	
4. TITLE AND SUBTITLE <b>Principal Considerations In Large Energy-Storage Capacitor Banks</b>		5a. CONTRACT NUMBER	
		5b. GRANT NUMBER	
		5c. PROGRAM ELEMENT NUMBER	
6. AUTHOR(S)		5d. PROJECT NUMBER	
		5e. TASK NUMBER	
		5f. WORK UNIT NUMBER	
7. PERFORMING ORGANIZATION NAME(S) AND ADDRESS(ES) <b>Los Alamos Scientific Laboratory Los Alamos, New Mexico 87545</b>		8. PERFORMING ORGANIZATION REPORT NUMBER	
9. SPONSORING/MONITORING AGENCY NAME(S) AND ADDRESS(ES)		10. SPONSOR/MONITOR'S ACRONYM(S)	
		11. SPONSOR/MONITOR'S REPORT NUMBER(S)	
12. DISTRIBUTION/AVAILABILITY STATEMENT <b>Approved for public release, distribution unlimited</b>			
13. SUPPLEMENTARY NOTES <b>See also ADM002371. 2013 IEEE Pulsed Power Conference, Digest of Technical Papers 1976-2013, and Abstracts of the 2013 IEEE International Conference on Plasma Science. Held in San Francisco, CA on 16-21 June 2013. U.S. Government or Federal Purpose Rights License.</b>			
14. ABSTRACT <b>Capacitor banks storing one or more megajoules and costing more than one million dollars have unique problems not often found in smaller systems. Two large banks, Scyllac at Los Alamos and Shiva at Livermore, are used as models of large, complex systems. Scyllac is a 10-MJ, 60-kV thetapinch system while Shiva is a 20-MJ, 20-kV energy system for laser flash lamps.</b>			
15. SUBJECT TERMS			
16. SECURITY CLASSIFICATION OF:			17. LIMITATION OF ABSTRACT <b>SAR</b>
a. REPORT <b>unclassified</b>	b. ABSTRACT <b>unclassified</b>	c. THIS PAGE <b>unclassified</b>	
			18. NUMBER OF PAGES <b>10</b>
			19a. NAME OF RESPONSIBLE PERSON

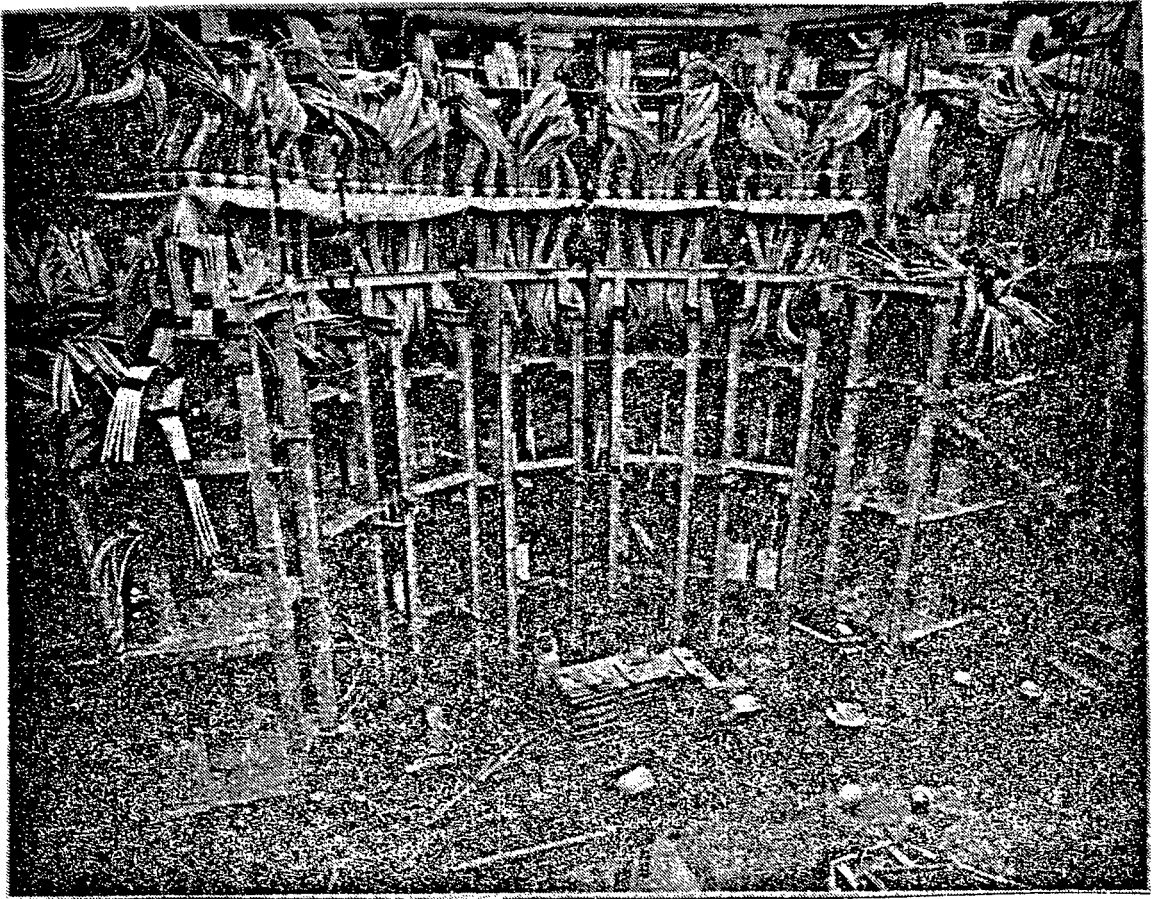

Fig. 1. Scyllac capacitor banks during construction.

bank was built in 1974 for about 20 cents per joule. It must be emphasized that the criteria for these two systems were considerably different. The Scyllac system drives a few-nanohenry load coil delivering over 100 MA in 3-4  $\mu$ s and is crowbarred. The principal components for Scyllac were developed during the design phase and were at the edge of the state-of-the-art. Reliability was compromised for performance. The Shiva bank drives a large number of flash lamps in a slow risetime, non-reversing circuit. Reliability was a major consideration so conservative designs were used whenever possible. Both systems meet their criteria specifications adequately.

#### Design Tenets

The design of a large capacitor bank often takes one to two years. Recognizing a few basic tenets can make this process go more smoothly and minimize the design time and cost.

The criteria should be completely specified at the very beginning. As in all system design, everything affects almost everything else. New requirements late in the design phase can impact or nullify many completed designs. Careful review of the criteria is a cost-effective exercise in the early phase of the project.

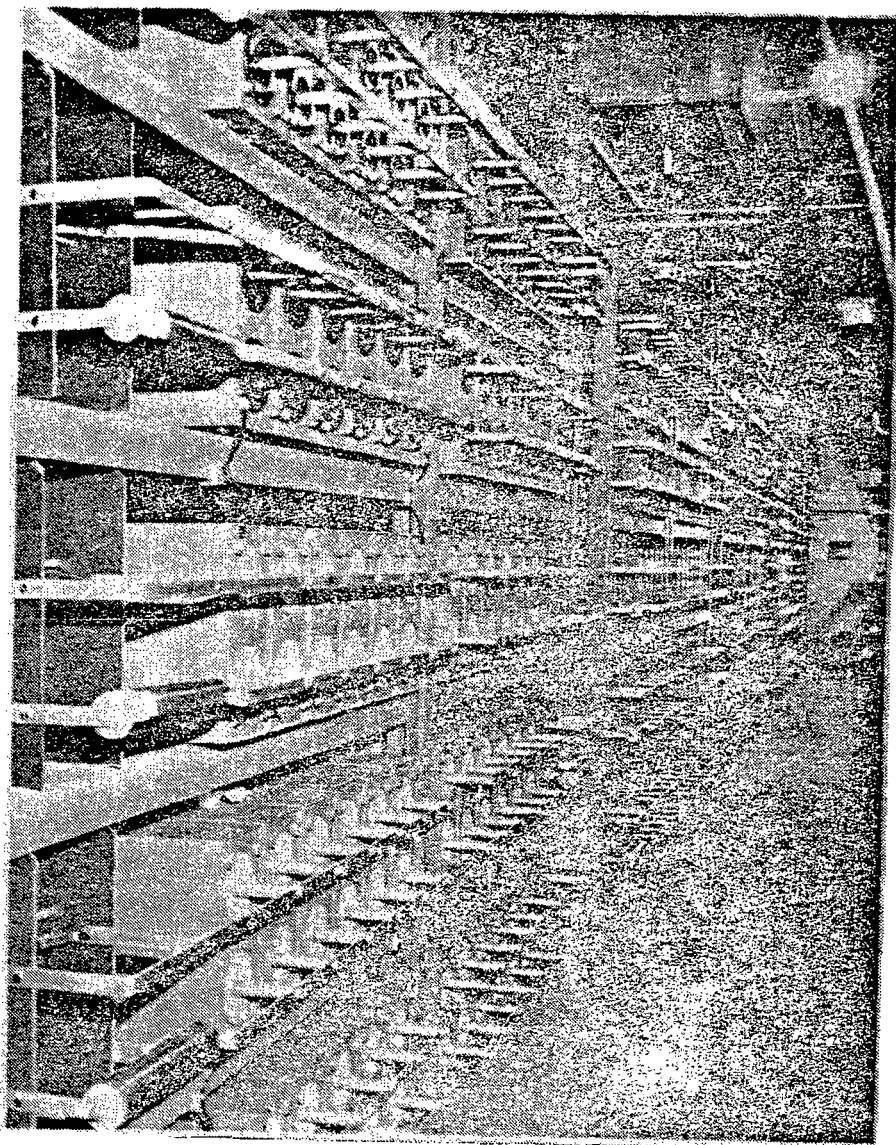

Fig. 2. Shiva capacitor banks.

The system design should be directed to meet the specified criteria. While many designs may meet the criteria, cost and time considerations must limit the design options in order to keep the project within the budget and on schedule.

Large systems must use conservative designs. Even modest design changes can be devastating. The simple addition of one charge resistor in the Scyllac circuit during construction cost over \$10,000 for the components and several man-weeks of installation. All new and novel designs should be tested in a substantial prototype system before they are approved for the main system.

Installation and maintainability are two requirements that must be incorporated into all designs. It must be appreciated that the installation cost of most electrical components is typically 20% of the component cost. Installation cost can be minimized by prefabricating and

preassembling many components before they are installed. For instance, the capacitors in the Shiva system were assembled into the racks and connected before the module was installed in the system. Much of the air distribution system of Scyllac was also prefabricated before installation.

Maintenance is often ignored by designers. All design reviews should address the operating and maintenance features of the design.

Finally, remember the control system. Often the majority of the energy system is designed before the control system is considered. After a number of the energy subsystems are installed and ready to check out, it is awkward to discover there is no control system available. The design and installation of the control system should have a high priority in the program.

### Circuits

The system circuit will depend upon the application so no particular circuit will be analyzed here. Rather, a few general comments will be addressed to various subsystems of the circuit, including the charge system, the storage system layout, the switching system, and the transmission system.

Large banks should be charged at a constant current. An RC charge system takes a long time or requires a very large power supply, and the energy dissipated in the resistor equals the energy stored in the bank. There are a variety of constant-current charging systems. Scyllac uses monocyclic networks, shown in Fig. 3, for the main charging system. Monocyclic networks are one of the least expensive methods for controlling large KVA power supplies, but they must always be connected to a load or they will generate extremely high voltages with accompanying spectacular arcs. The Shiva bank uses the three-phase voltage doubling circuit shown in Fig. 4. Like the monocyclic network, it can operate continuously into a short circuit. Both circuits use only passive components which enhance their reliability.

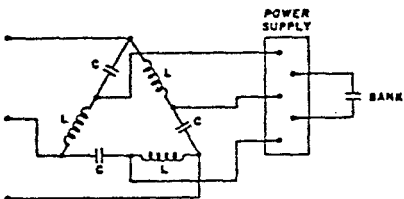

Fig. 3. Scyllac monocyclic network circuit.

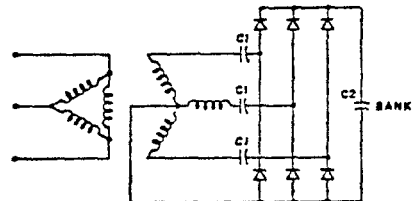

Fig. 4. Shiva voltage doubler circuit.

Scyllac uses vacuum-tube rectifiers in the power supplies while Shiva uses solid-state rectifiers. Although vacuum tubes require filament power and have a limited life, they are more forgiving to transients which always occur during system checkout, and occasionally during operations. Modern solid-state power supplies are now operating satisfactorily in Scylla IV-P, which is similar to Scyllac, after the rectifiers were changed to have an adequate PIV rating. The capacitors will ring occasionally and the rectifiers must accommodate the reverse load voltage, as well as the normal PIV.

The principal safety features of the entire bank are incorporated in the charge system. These include the dump circuit for passively discharging the bank when a shot aborts and the manual shorting system to short out a particular capacitor before it is physically touched. Convenient shorting places should be built into the charge system with shorting sticks permanently located at these locations.

There are a host of options for bank layout. The Shiva system, shown in Fig. 2, places the capacitors on their edge so that the aisle can be used for high-voltage isolation, as well as maintenance access. Six capacitors are also connected solidly together. The typical energy-storage capacitor can absorb 25 to 30 kJ without rupture so the Shiva design of 18 kJ is conservative.

The switching system is often the most critical item in the entire bank. Prefires and failures to fire may generate transients that destroy or injure many other components. In the Scyllac system a crowbar failure to fire allowed the bank to ring and broke the plasma discharge tube which shut the experiment down for three weeks. Although the crowbar trigger system was cross triggered and redundant, this event happened twice. Exhaustive diagnosis eventually revealed that an intermittent transient was getting back to the master clock and resetting it before it generated the crowbar trigger signal. This problem was overcome by taking a back-up signal from the bank to fire the crowbar system slightly later than the normal clock signal. Failure analysis should be performed on all large systems before the final design is approved.

When possible the switches should be physically grouped together. Such designs minimize installation costs, simplify the trigger system, and enhance operations and maintenance.

There are two generic transmission systems: solid conductors and coaxial cables. Solid conductor systems are often attractive because they can be built for almost any reasonable inductance and resistance characteristic, and you can do it yourself. However, in practice a few problems arise. The physical system must be located exactly as designed, there is very little flexibility with solid conductors. Small particles of foreign matter can penetrate between the conductors and eventually cause electrical failure. Finally, the magnetic force between conductors can be a very significant problem.

Coaxial cable has certain advantages for transmission systems. It is commercially available and fairly inexpensive. It is mechanically flexible, contains the magnetic forces, and also the magnetic field which minimizes electromagnetic noise problems. A coaxial cable system can be designed for low inductance by paralleling cables, so the net transmission line inductance competes well with a solid conductor system.

### Components

The principal components of an energy storage capacitor bank are the capacitors, the switches, and the coaxial transmission cable. Some features of these components will be discussed. Figure 5 shows two energy-storage capacitors. The 1.85- $\mu$ F, 60-kV capacitor has 22-nH self-inductance

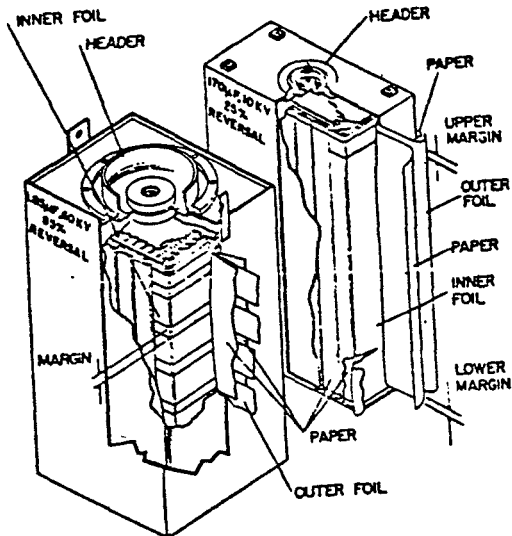

Fig. 5. Energy storage capacitors.

and has a life of about 50,000 shots with 85% voltage reversal. This capacitor stores 3300 J at 0.85 J/in.<sup>3</sup>. Recently a 2.8- $\mu$ F unit has been developed with a life of about 50,000 shots at 15% voltage reversal. It stores 5100 J at 1.3 J/in.<sup>3</sup>. The 170- $\mu$ F, 10-kV capacitor shown has a life exceeding 250,000 shots at 15% voltage reversal. This capacitor stores 8500 J at 3.5 J/in.<sup>3</sup>. Both of these capacitors are made with Kraft paper and impregnated with castor oil. Recently the 10-kV design has been made with paper and film and impregnated with another type of impregnant. It has an even higher energy density and lifetimes exceeding 50,000 shots at 15% reversal.

The ignitrons shown in Fig. 6 are about the only commercial switches available for capacitor bank switching. Ignitrons are economical and easy to trigger. They can be used as start switches and also as crowbar switches. The size A ignitron on the left is available with graphite, stainless-steel or molybdenum anodes. The graphite anode model is the least expensive and operates satisfactorily below 10 kV at modest non-reversing current. It is easy to trigger and preferred for slow pulses. The stainless-steel anode is satisfactory for about 15 kV with unidirectional or oscillating current. It may extinguish on long, slow pulses and the most common cause of failure is ignitor wetting. The molybdenum anode model is the most expensive and can be operated in fairly large numbers (50 to 100) at 20 kV. When the anode is heated to  $\sim$  80 to 100°C, a number of these ignitrons have been operated at 40 kV in a non-reversing circuit. All size A ignitrons should be limited to 30 coulombs.

The size D ignitron shown on the right in Fig. 6 has a graphite anode and water-cooling jacket. It is usually limited to 10 kV and  $\sim$  100 kA. Shiva uses two of these ignitrons in series for 20 kV. This ignitron is often used in crowbar service because of its high coulomb capacity. While rated at 200 C, some versions have run for over 10,000 shots at 90 kA and 1700 C.

Although ignitrons can be used in series for high-voltage banks, they become too inductive for many applications. Pressurized spark gaps can be designed for almost any voltage. Most designs have a limited voltage range, and require a sophisticated trigger system and a well controlled pressurized air system.

The Scyllac spark gap is shown in Fig. 7. The four-element start gap is at the bottom and the ferrite isolated crowbar gap is at the top. The two gaps operate at about 1 atm positive with very dry, clean air, but at slightly different pressures. The combined inductance of the start gap and capacitor is 60 nH. Over 3000 of these gaps have operated simultaneously in Scyllac with a 5% prefire rate and a jitter not exceeding 20 ns.

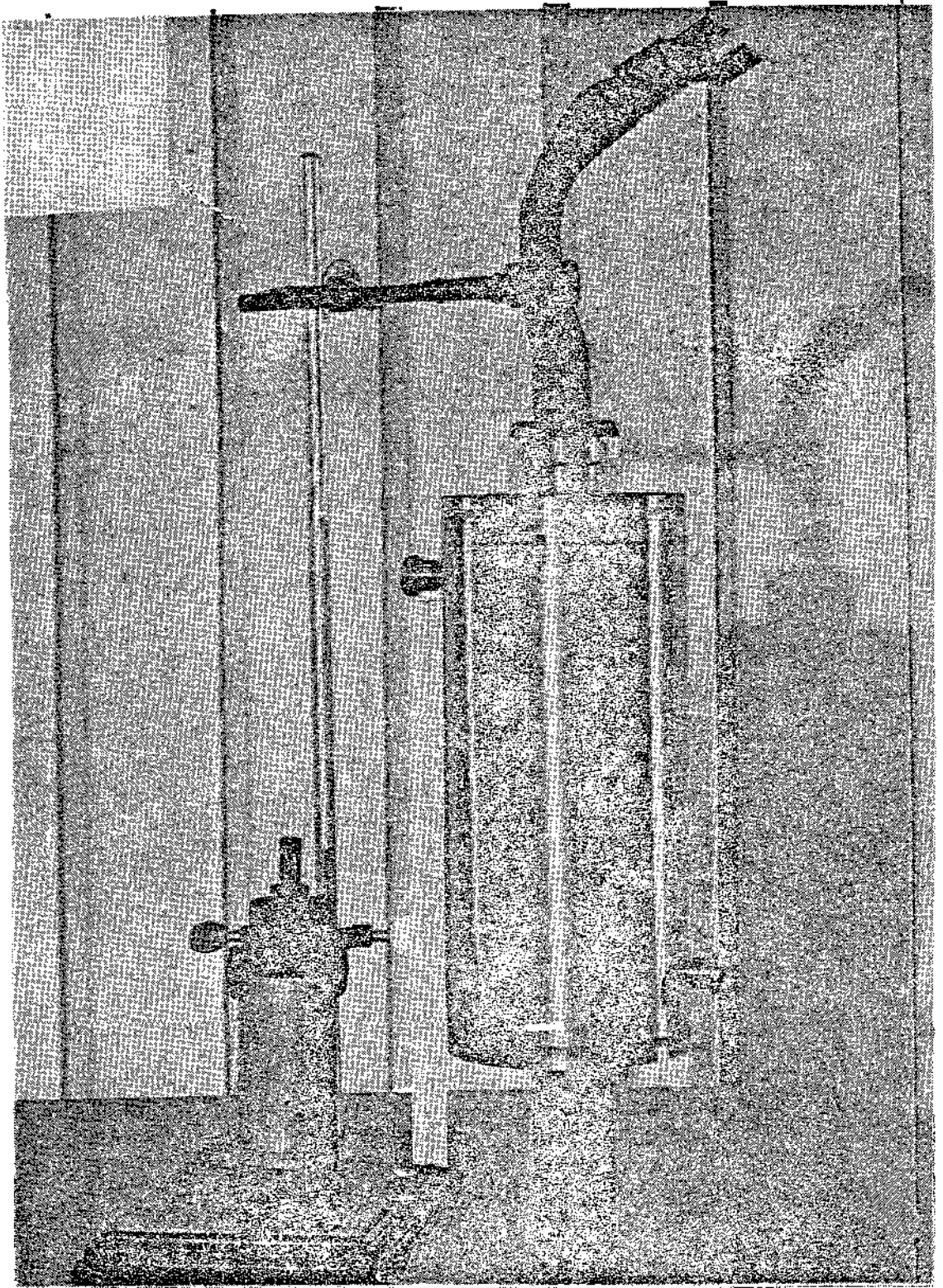

Fig. 6. Size A and size D ignitrons.

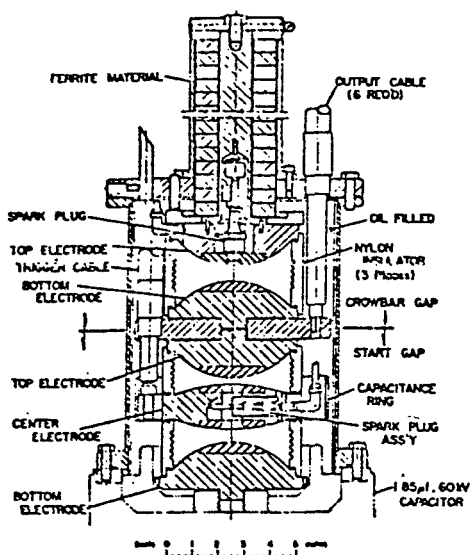

Fig. 7. Scyllac spark gap.

Scyllac cable was pretested with 50% over-voltage pulses for 10,000 shots before it was installed. Less than 5% of the cables failed during the test and most of these were due to termination failures.

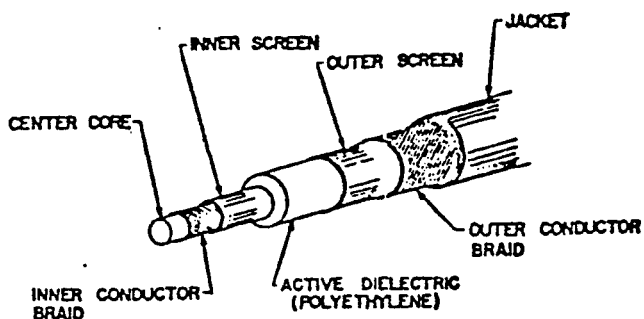

Fig. 8 Low-inductance cable design.

Fig. 8 shows the design of the low-inductance cable used in Scyllac. The center core is foamed polyethylene to improve the cable flexibility. The active dielectric is protected on both sides by conducting plastic screens. Over 500,000 feet of this type of cable is installed in Scyllac, and only two body failures have occurred in over 10,000 system shots. Each

## Project Management

Careful project management is essential for a multimillion dollar system that may take one to four years to complete. The primary considerations in project management are schedule and budget. The development, design and installation must be guided by the schedule and budget. In general it is better to plan and then organize around the plan rather than to limit the planning to the available organization. The plan must also include contingencies. Rarely does the funding arrive as requested in the original proposal so the planning must accommodate several funding delays.

The planning must involve a CPM or PERT chart. These charts will have many simultaneous activity lines, but each line should contain the common features shown in Fig. 9. As has been stated before, the criteria should be completely established first. At that point any development can commence and must be completed by the time the final design is complete. The conceptual design should be reviewed to see if it meets all the criteria. Conceptual design and preliminary design can interact with the preliminary design, actually determining the feasibility of the concept.

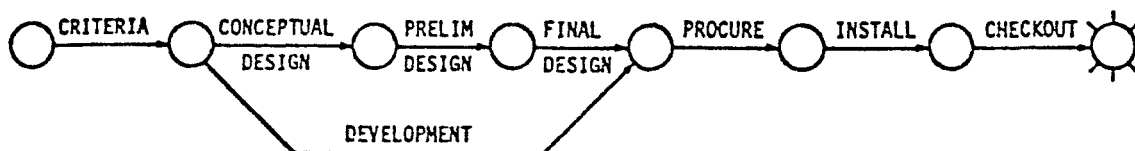

Fig. 9. Common features for a PERT chart.

A formal design review of the preliminary design is essential before the final design begins. At this review the preliminary design must be considered for meeting the performance criteria, as well as for cost, reliability, etc. This review is probably the most important review in the entire process. Final design can then proceed uninhibited by any new criteria or other frightful surprises. The review of the final design must be thorough since this design determines the cost.

Procurement may proceed when funding is available. Often it is necessary to generate an entirely new PERT chart for the installation and checkout. The installation PERT chart should be generated before procurement begins because new critical paths may be revealed which influence procurement obligations.

The budget is equally as important as the schedule. An understandable accounting system must be established before any significant costs are incurred. The PERT chart should be reviewed periodically in comparison with the budget to determine if the progress is abreast with the budget. Cost estimates for the material identified on the PERT must be continually reviewed. It is important to examine the engineering costs for accomplishing the various design goals. This is particularly true for the development program.

Large projects proceed in three phases: design, installation and checkout. In principle, the design engineer should be given the opportunity to follow his design through procurement, installation and checkout, but in reality, this becomes far too expensive. The installation and checkout engineers, who may also be doing some design work, should be designated early and they should follow the designs for which they are responsible. This allows the various designers to drop off the project as soon as their designs are complete. If this policy is clearly stated at the beginning, it avoids certain types of conflicts later in the project.

The installation usually involves union craftsmen working alongside skilled technicians.<sup>3</sup> Although the Davis-Bacon determination will identify what activities are appropriate to each group, some conflicts inevitably arise. Weekly meetings of the crafts foremen, the technician supervisors, and installation engineers usually alleviate many of the personnel and technical problems.

### Operations

There are two components to operations: technical management and personnel management. The most important step in technical management is to clearly designate the supervisors and define their technical responsibilities. This eliminates a host of problems. Then an operating procedure should be established, and an SOP written and faithfully followed. This is essential for personnel safety. It is vital to recognize that checkout and initial operations are the most hazardous times of the entire project and personnel safety must not be compromised during these critical periods. A technique must be established to review all proposed changes and document them when they are completed. If possible, the design engineers should also be consulted when significant changes are proposed.

Large systems usually operate for several years and morale often becomes a major problem with the operations crew. While each organization will have its own techniques for operations, a clear delegation of responsibilities is essential for good morale. A continuing formal training program is a productive method of showing interest in the professional development of the operating crew over the long haul. The usual parties as various milestones are met must not be overlooked.

### References

<sup>1</sup>E. L. Kemp, "The Final Design of Scyllac," Proc. of Symposium on Engineering Problems of Fusion Research, Los Alamos Scientific Laboratory Report LA-4250 (1969).

<sup>2</sup>G. R. Allen, W. L. Gagnon, P. R. Rupert, and J. B. Trenholme, "Engineering Storage and Power Conditioning System for the Shiva Laser Sixth Symposium on Engineering Problems of Fusion Research, IEEE Pub. 75CH1097-5-NPS.

<sup>3</sup>W. H. Harris, E. L. Kemp, W. E. Quinn, and F. L. Ribe, "Project Management of Scyllac Construction," Fifth Symposium on Engineering Problems of Fusion Research, IEEE Pub. 73CH0843-3-NPS.