

HIGH POWER CX 1536A THYRATRON

J. C. O'Connell
 US Army Electronics Technology & Devices Laboratory (ERADCOM)
 Fort Monmouth, NJ 07703

Summary

The development of the Megawatt Average Power (MAPS-40) thyatron for multimewatt pulsers was a major factor in reducing power conditioning subsystem size and weight for mobile military applications.¹⁻² In addition to providing a tractable package size, the resulting reduction in component count permitted by a single large "super" thyatron has led to an improvement in subsystem reliability.³ This paper reports the evaluation of an English Electric Valve (EEV) CX 1536A thyatron to determine its suitability for megawatt (MW) average power operation. The tube represents a first cut by EEV at modifying one of their standard CX 1536 thyatron to handle higher peak current. Poor inverse voltage hold-off occurred above 30 kilovolts (kV) preventing the CX 1536A from reaching the MW average power level. The maximum average power achieved was 0.4 MW and an operational envelope for rep-rate and anode voltage (E_{py}) determined.

The CX 1536A Thyatron

A standard EEV CX 1536 thyatron is a two gap deuterium filled tube with peak anode voltage rating of 70 kV, peak anode current of 10 kiloamperes (kA) and average anode current of 10 amperes (A) maximum. EEV modified this thyatron to test against MAPS-40 objective given in Table 1.

Table 1

MAPS-40 Design Objectives

Peak Anode Voltage, E_{py}	40 kV
Peak Anode Current, i_b	40 kA
dc Average Current, I_b	50 A
RMS Average Current, I_p	1400 AAC
Pulse Repetition Rate, PRR	125 Hz
Anode Delay Time Drift, $\Delta\tau_{AD}$	0.1 μ s
Life	1X10 ⁶ shots
Operating Mode	30 S burst

The modifications included increasing the grid aperture and incorporating a heavier anode to meet increased current demand. A critical issue was whether a large enough grid aperture could be provided in a 6 inch diameter tube for the 40 kA peak current demand. The gross dimensions of the thyatron shown in Figure 1 remain unchanged.

The advantages to be obtained from the successful application of the CX 1536A compared to the MAPS-40 thyatron are listed in Table 2.

Table 2

Comparison of CX 1536A and MAPS-40 Thyratrons

	CX1536A	MAPS-40
Length	14.9 in.	12.6 in.
Diameter	6.0 in.	9.0 in.
Weight	15 lbs.	44 lbs.
Heater/Reservoir Power	600 W.	1600 W.

The reduction in size and weight that could be achieved would permit higher packing density in mobile pulser subsystems and reduced standby power would be required for cathode and reservoir heater power.

Thyatron Testing

The CX 1536A thyatron was evaluated in two separate 1 MW line type modulators. The first consisted of three parallel seven-section pulse forming networks (PFNs) with a total impedance of 0.5 ohms (Ω) discharging into a 0.5 Ω copper sulfate liquid load. The pulse width is 10 microseconds (μ s). This circuit is normally employed to age MAPS-40 thyratrons.

The CX 1536A was also operated in a compact MW modulator.⁴ It consisted of two six-section PFNs which with appropriate strapping produce a 10 or 20 μ s pulses. In addition to the liquid load a resistor bank consisting of 70 parallel 35 Ω silicon carbide resistors were used to produce a 0.5 Ω load resistance.

Both modulators had end-of-line clipper circuits consisting of a solid state diode stack in series with a matched load. The series combination is connected with the end capacitors of the PFNs. The diode stack has 40 Westinghouse type 1N4594 diodes. These diodes are rated for 1000 volts (V) peak inverse voltage at 150A. A matched resistor is obtained by paralleling two 1 Ω resistor stacks of four 0.25 Ω carborundum washer resistors.

An EG&G TM-30 Trigger Module was used to provide grid drive to both of the CX 1536A grids, Figure 2. Two 20 megohm ($M\Omega$) resistor strings were connected across the gradient grids for voltage division. Initially both the cathode and reservoir heater were run off of the same 6.3 VAC transformer. Later a separate transformer was provided for independent control of each.

Test Results MAPS-40 Aging Rack

The CX 1536A thyatron was socketed in the MAPS-40 aging rack and the anode voltage, E_{py} , was increased at low rep-rate, 7 hertz (Hz). An aging period of approximately 6 hours was required to reach reliable operation (elimination of prefires) at an E_{py} of 30 kV. At the nominal heater and reservoir setting, 6.3 VAC, inverse current through the thyatron occurred at $E_{py} > 23$ kV.

Both heater and reservoir temperature were varied in an attempt to improve inverse voltage hold-off. Figure 3 shows the variation of E_{py} at the onset of inverse current as a function of heater current. Improvement occurred up to 7.0 VAC, 90 A and subsequent testing was made under that condition. The reservoir was varied between 4.0 VAC, where quenching was observed at the end of the current pulse, and 7.0 VAC. Inverse voltage hold-off was not sensitive to reservoir temperature and in fact the thyatron has an internal baretter which minimizes the ability to control this parameter.

Report Documentation Page

Form Approved
OMB No. 0704-0188

Public reporting burden for the collection of information is estimated to average 1 hour per response, including the time for reviewing instructions, searching existing data sources, gathering and maintaining the data needed, and completing and reviewing the collection of information. Send comments regarding this burden estimate or any other aspect of this collection of information, including suggestions for reducing this burden, to Washington Headquarters Services, Directorate for Information Operations and Reports, 1215 Jefferson Davis Highway, Suite 1204, Arlington VA 22202-4302. Respondents should be aware that notwithstanding any other provision of law, no person shall be subject to a penalty for failing to comply with a collection of information if it does not display a currently valid OMB control number.

1. REPORT DATE JUN 1981	2. REPORT TYPE N/A	3. DATES COVERED -			
4. TITLE AND SUBTITLE High Power Cx 1536a Thyatron		5a. CONTRACT NUMBER			
		5b. GRANT NUMBER			
		5c. PROGRAM ELEMENT NUMBER			
6. AUTHOR(S)		5d. PROJECT NUMBER			
		5e. TASK NUMBER			
		5f. WORK UNIT NUMBER			
7. PERFORMING ORGANIZATION NAME(S) AND ADDRESS(ES) US Army Electronics Technology & Devices Laboratory (ERADCOM) Fort Monmouth, NJ 07703		8. PERFORMING ORGANIZATION REPORT NUMBER			
9. SPONSORING/MONITORING AGENCY NAME(S) AND ADDRESS(ES)		10. SPONSOR/MONITOR'S ACRONYM(S)			
		11. SPONSOR/MONITOR'S REPORT NUMBER(S)			
12. DISTRIBUTION/AVAILABILITY STATEMENT Approved for public release, distribution unlimited					
13. SUPPLEMENTARY NOTES See also ADM002371. 2013 IEEE Pulsed Power Conference, Digest of Technical Papers 1976-2013, and Abstracts of the 2013 IEEE International Conference on Plasma Science. Held in San Francisco, CA on 16-21 June 2013. U.S. Government or Federal Purpose Rights License.					
14. ABSTRACT					
15. SUBJECT TERMS					
16. SECURITY CLASSIFICATION OF:			17. LIMITATION OF ABSTRACT SAR	18. NUMBER OF PAGES 3	19a. NAME OF RESPONSIBLE PERSON
a. REPORT unclassified	b. ABSTRACT unclassified	c. THIS PAGE unclassified			

At the optimum heater temperature, Figure 4 shows the 10 μ s current pulse at $E_{py} = 27$ kV and the current (320A peak) through the end-of-line clipper circuit. Figure 5 shows in comparison, the same data at 30 kV. Intermittent clipping occurs. Peak inverse current is 800A. Subsequently, the thyatron was run for approximately 200 pulses at $E_{py} = 36$ kV where the peak inverse current was 1,300A. Further testing at high anode voltage was eliminated to prevent damage to the cathode due to arcing.

Compact Megawatt Modulator

The CX 1536A thyatron was placed in the compact MW modulator which provided a much better pulse shape as shown in Figure 6. No improvement in reverse hold-off was obtained. The thyatron was adjusted for an $E_{py} = 25$ kV and the rep-rate was increased until stable operation was obtained at 125 Hz average power. The thyatron was operated in a burst mode of 5 seconds on - 45 seconds off for a series of 10 bursts at an average power of 0.39 MW.

Conclusions

The EEV CX 1536A thyatron which was evaluated for MW average power applications was limited to anode voltages less than 27 kV and as a result was limited to approximately 400 kilowatts (kW) at the maximum repetition rate of 125 Hz. This limitation resulted from the inability to achieve reverse hold-off above that level. In a similar manner, this parallels a problem encountered in the development of the MAPS-40 thyatron where operation at the MW average power level was achieved only after a suitable end-of-line clipper was incorporated in the modulator circuit. Although the same clipper circuit was employed in the CX 1536A circuit, breakdown in the inverse direction occurs at voltages as low as 1 kV and the solid state diodes although sized to handle the inverse current are too slow for this application.⁵ Continued evaluation of the CX 1536A will incorporate a second thyatron as an end-of-line clipper to eliminate the inverse hold-off problem and allow operation at higher average power levels.

References

1. J. Creedon, S. Schneider. "Megawatt Average Power Adiabatic Mode Thyatrons," Proc. of the IEEE International Pulsed Power Conf, Nov 1976
2. D. Turnquist, et al, "The MAPS-40 Burst Mode 40 kV Megawatt Average Power Thyatron," IEEE Trans. on Electron Devices, Vol. ED-26, No. 10, Oct 1979
3. J. O'Connell, et al, "Upgraded Brassboard Pulser for HELS," to be presented at 3rd Inter. Pulsed Power Conf., June 1981
4. J.E. Creedon, et al, "Compact Megawatt Average Power Pulse Generator," IEEE Trans. on Electron Devices, Vol. ED-26, No. 10, Oct 1979
5. S. Levy, "Solid State PFN Clipper Stack Analyzer Under High Peak Power Conditions," to be pres. at 3rd Inter. Pulsed Power Conf., June 1981

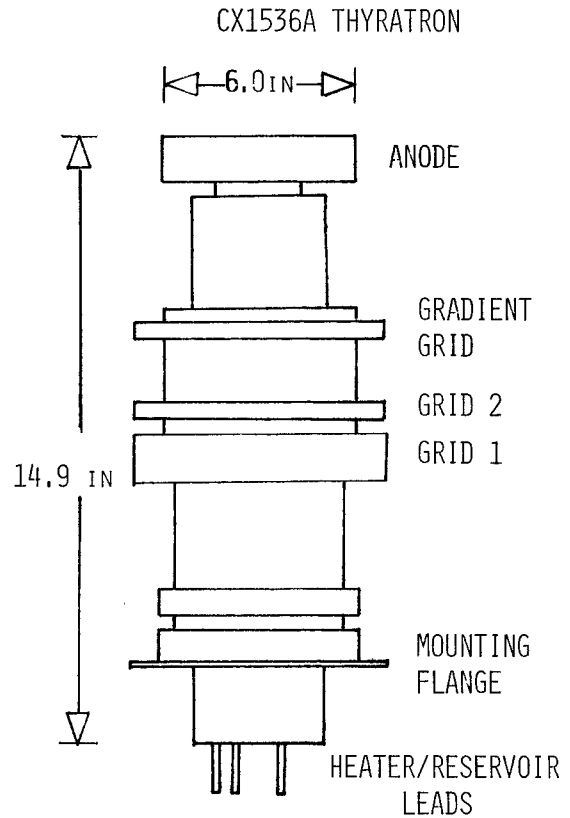

Figure 1. The CX 1536A Thyatron

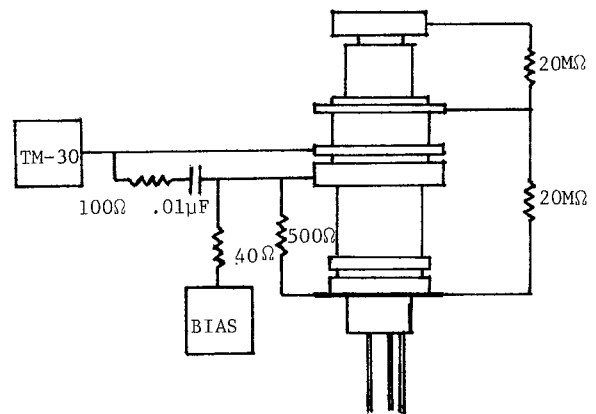

Figure 2. Control and Gradient Grid Connection

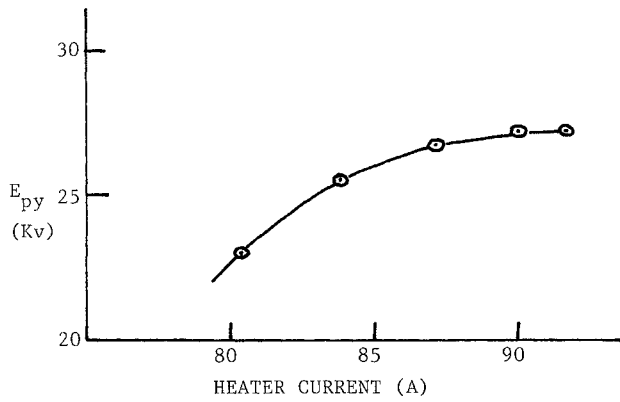

Figure 3. Anode Voltage (E_{py}) at the Onset of Inverse Current as a Function of Heater Current

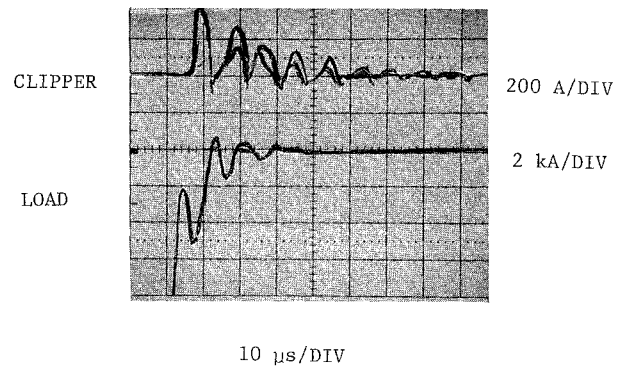

Figure 5. Load Current and End-of-Line Clipper Circuit at $E_{py} = 30$ kV for Aging Rack Modulator with CX 1536A Thyatron

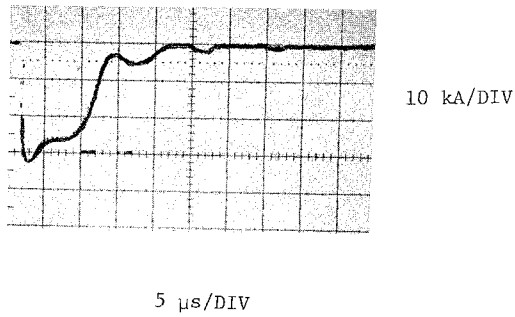

Figure 4a. Load Current at $E_{py} = 27$ kV for Aging Rack Modulator with CX 1536A Thyatron

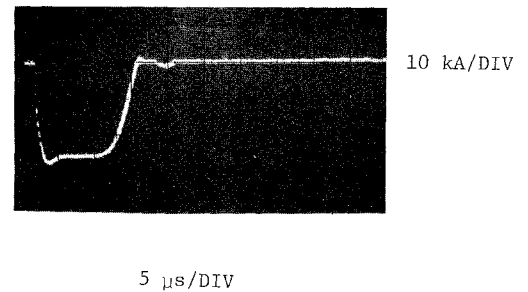

Figure 6. Load Current at $E_{py} = 25$ kV for Compact Megawatt Modulator with CX 1536A Thyatron

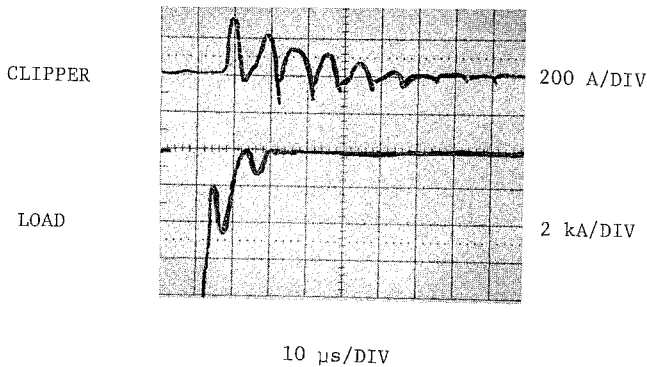

Figure 4b. Load Current and End-of-Line Clipper Circuit at $E_{py} = 27$ kV for Aging Rack Modulator with CX 1536A Thyatron