

PARALLEL OPERATION OF THYRATRONS IN LOW INDUCTANCE DISCHARGE CIRCUITS

Glen McDuff
 Los Alamos National Laboratory
 P.O. Box 1663
 Los Alamos, NM 87545

Abstract

The long-life, low-loss switch requirements of the Molecular Laser Isotope Separation program have focussed much attention on the possible application of hydrogen thytrons in electrical discharge excimer laser systems. Special low inductance, high dI/dt thytrons have been developed for use in low impedance discharge circuits. Even though thytrons meet the life and loss requirements, state-of-the-art devices are peak-current-limited at the high repetition rates required by the laser system. To overcome this drawback, several thytrons can be operated in parallel. Current sharing forced by individual ballast elements is not allowed since this would result in excessive inductance and reduced dI/dt . Instead, the thytrons are connected in "hard" parallel in a stripline circuit; that is, the anodes are connected together using a stripline and the cathodes are similarly connected. Equal current sharing between tubes is then easily accomplished by adjusting the grid bias so that the tubes commute within 1 ns of each other. A microprocessor-based control circuit monitors tube currents using special current viewing resistors (CVR's)* and makes appropriate adjustments in the grid bias to maintain current sharing. Since each tube is controlled independently, many thytrons can be operated in a single laser circuit. A complete discussion of the thyatron circuit and the controls is included.

Introduction

Parallel operation of thytrons dates to the early 40's at the Evans Signal Laboratory where the first experiments of this type were performed. It was concluded that to operate thytrons in parallel a "balancing inductor" must be used to force equal current distribution between the tubes. There is very little documentation on parallel operation of thytrons, but of all data available, the consensus is that some type of impedance must be connected in series with each tube.^{1,2} A schematic of a typical parallel thyatron circuit is shown in Fig. 1.

Using inductive elements in series with the thytrons makes parallel operation possible but also increases the total inductance of the discharge loop. In low impedance, high- dI/dt laser drive circuits this added inductance is not acceptable.

Research conducted at the Los Alamos National Laboratory in the area of high-repetition-rate switching has resulted in the successful operation of thytrons in "hard" parallel. "Hard" parallel is defined as connecting the anodes directly to a common plate and connecting the cathodes in similar fashion.

The capability of operating thytrons hard parallel in low inductance circuits have several ramifications. Spark gaps with flow systems have provided the only means of switching high-current, short-pulse rep-rated systems, but parallel thytrons may soon replace these gaps. Thytrons have several advantages over spark gaps. They exhibit:

- 1) lower resistive loss (thus higher efficiency),
- 2) longer life,
- 3) no gas or air flow requirement,
- 4) lower, more controllable jitter,
- 5) higher power gain (thus higher efficiency) when compared to spark and rail gaps.

These points make a more efficient and economical system for long-term operation. The remainder of this report will discuss the experimental apparatus, principles of parallel operation, and areas of investigation.

Circuit Operation

A photograph of the parallel tube test circuit is seen in Fig. 2.

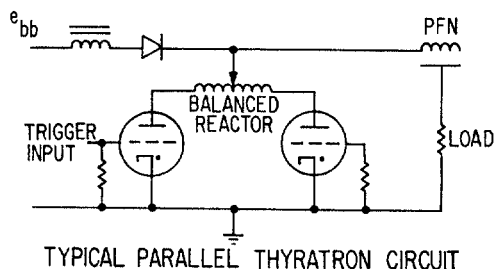

Fig. 1. Typical parallel thyatron circuit.



Fig. 2. Parallel tube test circuit.

*The special current viewing resistors are discussed in "Low Inductance Current Viewing Resistors for Hydrogen Thytrons," submitted by C. A. Muehlenweg of T & M Research Products, Inc.

Report Documentation Page

Form Approved
OMB No. 0704-0188

Public reporting burden for the collection of information is estimated to average 1 hour per response, including the time for reviewing instructions, searching existing data sources, gathering and maintaining the data needed, and completing and reviewing the collection of information. Send comments regarding this burden estimate or any other aspect of this collection of information, including suggestions for reducing this burden, to Washington Headquarters Services, Directorate for Information Operations and Reports, 1215 Jefferson Davis Highway, Suite 1204, Arlington VA 22202-4302. Respondents should be aware that notwithstanding any other provision of law, no person shall be subject to a penalty for failing to comply with a collection of information if it does not display a currently valid OMB control number.

1. REPORT DATE JUN 1981		2. REPORT TYPE N/A		3. DATES COVERED -	
4. TITLE AND SUBTITLE Parallel Operation Of Thyratrons In Low Inductance Discharge Circuits				5a. CONTRACT NUMBER	
				5b. GRANT NUMBER	
				5c. PROGRAM ELEMENT NUMBER	
6. AUTHOR(S)				5d. PROJECT NUMBER	
				5e. TASK NUMBER	
				5f. WORK UNIT NUMBER	
7. PERFORMING ORGANIZATION NAME(S) AND ADDRESS(ES) Los Alamos National Laboratory P.O. Box 1663 Los Alamos, NM 87545				8. PERFORMING ORGANIZATION REPORT NUMBER	
9. SPONSORING/MONITORING AGENCY NAME(S) AND ADDRESS(ES)				10. SPONSOR/MONITOR'S ACRONYM(S)	
				11. SPONSOR/MONITOR'S REPORT NUMBER(S)	
12. DISTRIBUTION/AVAILABILITY STATEMENT Approved for public release, distribution unlimited					
13. SUPPLEMENTARY NOTES See also ADM002371. 2013 IEEE Pulsed Power Conference, Digest of Technical Papers 1976-2013, and Abstracts of the 2013 IEEE International Conference on Plasma Science. Held in San Francisco, CA on 16-21 June 2013. U.S. Government or Federal Purpose Rights License.					
14. ABSTRACT The long-life, low-loss switch requirements of the Molecular Laser Isotope Separation program have focussed much at tent ion on the possible application of hydrogen thyratrons in electrical discharge excimer laser systems. Special low inductance, high di/dt thyratrons have been developed for use in low impedance discharge circuits. Even though thyratrons meet the life and loss requirements, state-of-the-art devices are peak-current-limited at the high repetition rates required by the laser system. To overcome this drawback, several thyratrons can be operated in parallel. Current sharing forced by individual ballast elements is not allowed since this would result in excessive inductance and reduced di/dt. Instead, the thyratrons are connected in "hard" parallel in a stripline circuit; that is, the anodes are connected together using a stripline and the cathodes are similarly connected.					
15. SUBJECT TERMS					
16. SECURITY CLASSIFICATION OF:			17. LIMITATION OF ABSTRACT SAR	18. NUMBER OF PAGES 4	19a. NAME OF RESPONSIBLE PERSON
a. REPORT unclassified	b. ABSTRACT unclassified	c. THIS PAGE unclassified			

Items of interest are:

- 1) the PFN,
- 2) the low-inductance, folded-foil load,
- 3) the two HY-3013 thyratrons, and
- 4) the two thyatron current viewing resistors

Circuit parameters for the initial test circuit were chosen so that the thyratrons would not be stressed in any way. An anode voltage of 25 kV and a PFN impedance of 25Ω will yield a peak current of 250 A per tube, which is one half the maximum cathode current rating. A relatively low dI/dt , 5×10^{10} A/s, was maintained, thus not exceeding the τ_b anode breakdown factor and keeping anode dissipation below 25 W per tube at 1250 pps. The 50 W total anode dissipation corresponds to 2.5% of the total power dissipated in the load. Operating at these parameters will make tube failure very unlikely so any problems encountered should be associated with "hard" parallel operation.

Results from previous experiments with HY-3013's indicated that for fastest switching time and lowest jitter, the control grid, G2, should be bypassed to the cathode with a 15 nF capacitor, and the auxiliary grid, G1, should be triggered. To achieve higher hold-off voltages and enhance recovery, for high repetition rates, negative bias is applied to G2 from a high impedance source. The most important effect of negative bias on G2 is that it changes the anode commutation delay time. The commutation delay time increases by approximately 300 ps for every volt negative bias applied to G2. Utilizing this aspect of thyatron behavior is one method which makes possible the "hard" parallel operation.

The schematic of the parallel thyatron switching circuit is seen in Fig. 3. Both HY-3013's are triggered from one driver capable of delivering two identical output pulses. The auxiliary grid, G1, is triggered with a 2000 V $1 \mu s$ pulse from the 50Ω source.

A fixed negative bias is applied to the control grid, G2, of HY-3013 #1. Thyatron pulse currents are monitored by computer-controlled, dual-channel waveform digitizers via the special low inductance (<3 nH) current viewing resistors. A computer-controlled power supply provides negative bias to the control grid of HY 3013 #2. If the current of HY-3013 #1 becomes larger

than that of HY-3013 #2, the negative bias of #2 is reduced. Likewise, if HY-3013 #1 pulse current becomes less than that of #2, the computer increases the negative bias on HY-3013 #2. A bias update is required approximately every 10 s to maintain equal current in the thyratrons at a repetition rate of 250 pps or below. At rep rates above 250 pps, an update must occur every second. (Note: The CVR's do add inductance in series with the thyratrons. However, the inductance of the CVR is <3 nH compared to the HY-3013's 25-30 nH inductance. Also the CVR's have a measured risetime of 750 ps, compared to the 15-20 ns switching time of the HY 3013.)

Replacing the digitizers and computer with high speed A to D converters and a microprocessor, update of negative bias is provided every 1 ms. This method of controlling current sharing in parallel thyratrons has two important features:

- 1) Many thyratrons can be operated in parallel since all are referenced to a single tube.
- 2) One driver can be used to provide identical trigger pulses to all thyratrons, which is beneficial in maintaining low jitter.

A practical limit of 5 thyratrons can be operated from one driver and one microprocessor controller at 1000 pps rep rate.

Experimental Investigation

Several areas of investigation have been and will be addressed in the parallel thyatron project. These areas are:

- 1) rep rate negative bias update,
- 2) jitter,
- 3) switching efficiency and loss,
- 4) and life.

The initial testing of the parallel tubes was done at 10 pps and rapidly increased to 250 pps. Negative bias adjustments were made manually with an update about every 5-10 s. At rep rates greater than 250 pps, negative bias update must be made by automated means. To perfect the operation of parallel thyratrons at 1000 pps rep rates, a high speed circuit to control negative bias was designed. A simplified block diagram of the

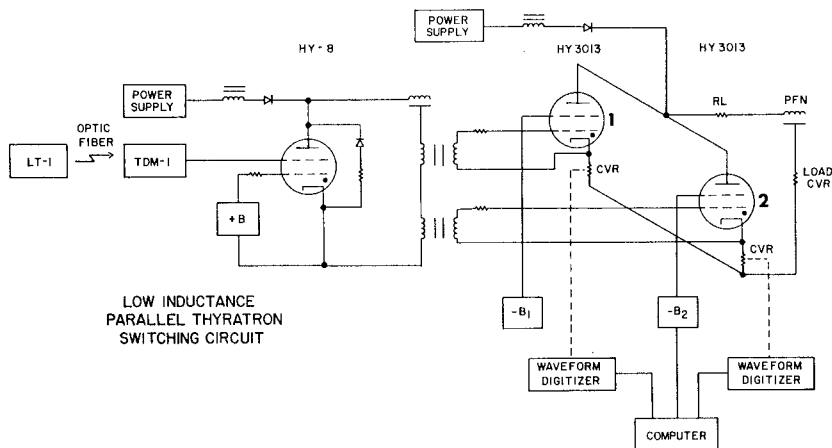

Fig. 3. Low inductance parallel thyatron switching circuit.

control circuit is seen in Fig. 4. The output of the thyatron CVR is converted to an 8-bit parallel signal with high-speed A-D converters. The digital signal from the A-D converters is fed to a Mostek Z-80 microprocessor through a Mostek 3881 in/out port. The Z-80 compares the signals and makes appropriate changes in the negative bias. (The actual process of the control circuitry is somewhat more complicated.) Settling time for a bias adjustment, that is, time from CVR signal to actual bias change is approximately 1 ms. Protection circuitry is provided in case the amplitudes of the CVR's are not within certain preset limits; if the limits are exceeded, the high voltage supply will be crowbarred.

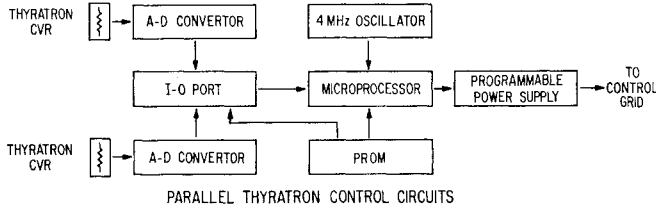

Fig. 4. Parallel thyatron control circuits.

Jitter is very important in the timing scheme for the Molecular Laser Isotope Separation Project. Therefore, it has been studied very carefully. With proper drive and proper circuit components, the overall circuit jitter is less than 2 ns peak to peak.

Loss in a thyatron is due mostly to the power dissipation during turn on or switching time (also known as anode fall time). To minimize loss, switching time, τ_s , must be minimized. Switching time is a function of tube pressure (reservoir voltage), drive, bias, and circuit components.

Appendix A contains graphs of switching time, τ_s , vs drive to G1 and negative bias on G2. It should be noted by varying only the drive, bias, and the G2 bypass capacitor, the switching time can be varied from 50 ns to 19.1 ns. At high reservoir voltages, 7.0 VAC, switching times of 15.5 ns have been achieved at 25 kV anode voltage (resonant charging). Acquiring thyatron life data is a slow process due to long life times. However, for the HY-3013, the following parameters have been consistent with a normal thyatron life:

Anode Voltage (Resonant Charged)	e_{py}	25 kV
Pulsed Current	i_b	500 A
Pulse Width	τ	250 ns
Switching Time (Anode Falltime)	τ_s	20 ns
Repetition Rate	prf	1250 pps
Lifetime (# of shots)		10^9

Autopsies of HY-3013s operated at the above parameters have shown that life was limited by cathode depletion. The cathode was evenly utilized. No signs of hydrogen depletion were noticed and there was very little crystallization of the reservoir.

Conclusions

Successfully operating thyatrons in "hard" parallel have made possible the use of these devices in high peak current, high rep rate circuits. Ongoing work with this technique will include high di/dt testing, life test, and multiple parallel tube circuits. Parallel thyatrons are geometrically oriented for use in striplines and large laser assemblies. High power gain and long life make thyatrons a viable choice over spark and rail gaps.

Thyatron technology in design, construction, and operation is advancing at a record pace. Large diameter, low inductance thyatrons and tubes requiring no heater or reservoir power are being built and tested. All these features along with the fact that once operational, a thyatron circuit is practically maintenance free, will make thyatrons the logical choice for high power switching in many future applications.

References

1. Pulse Generators, edited by G. N. Glasoe and J. V. Lebacqz, Dover Publications Inc., 1965, New York, N.Y.
2. Hydrogen Thyatron Preamble, English Electric Valve Co., 1972.

Acknowledgement

Special thanks to David Turnquist of EG&G for assistance in thyatron autopsies.

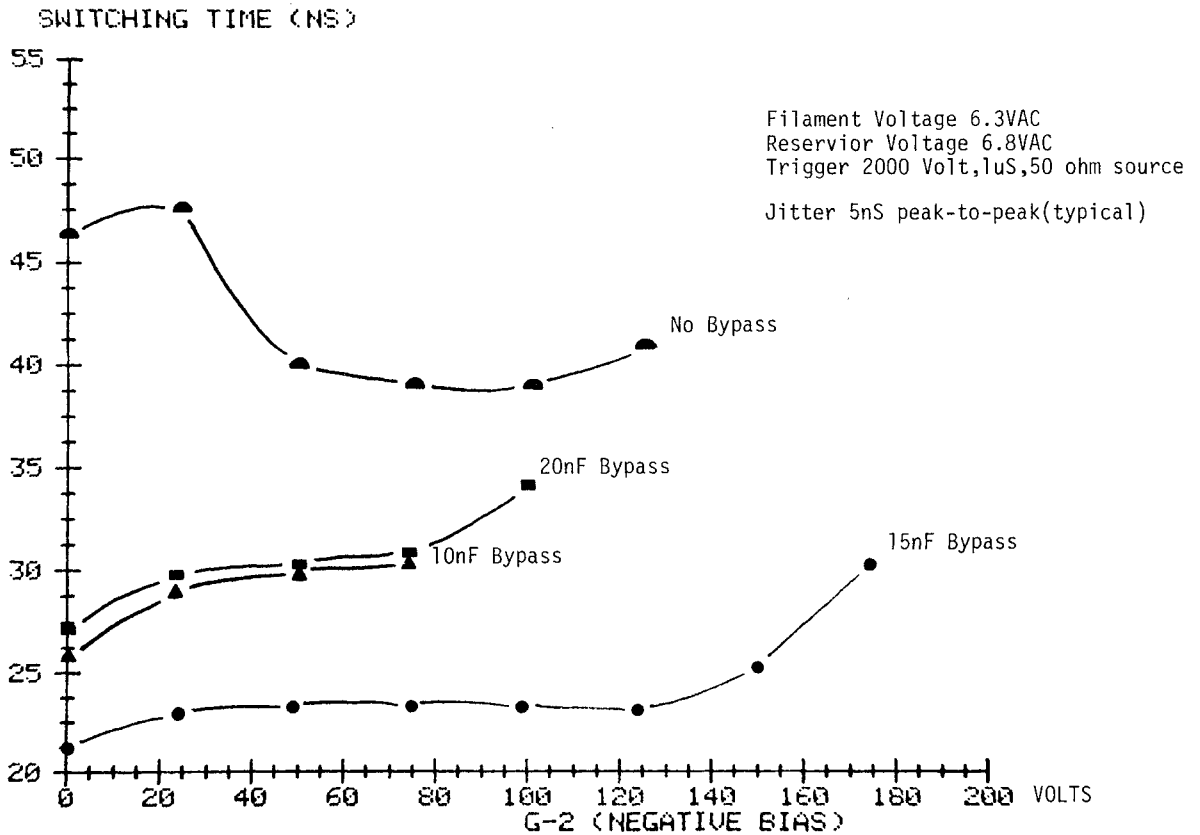
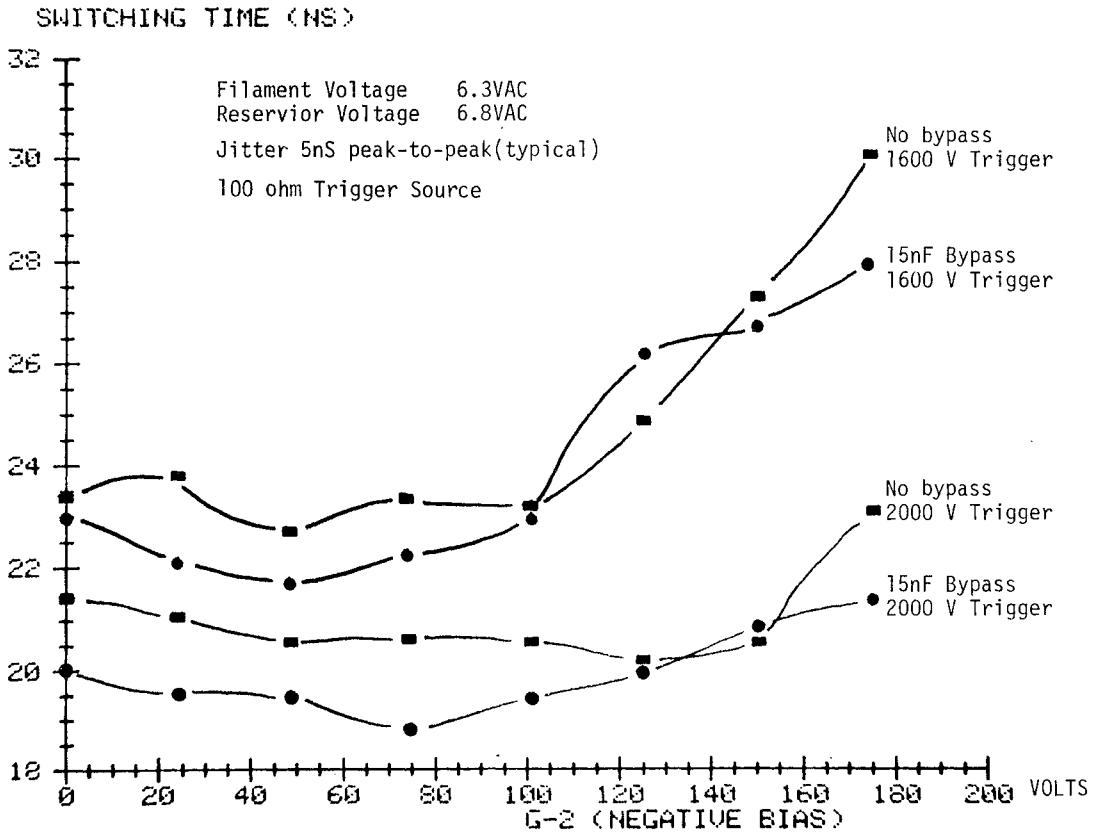

APPENDIX A

Switching time measurements for the HY-3013 as a function of drive, bias, and circuit component values.