

PARALLEL-PLATE WINDINGS TRANSFORMER FOR PULSED POWER APPLICATIONS*

John D. Galbraith
 Los Alamos National Laboratory
 Mail Stop 644
 Los Alamos, New Mexico 87545

Summary

Two sizes of the parallel-plate windings transformer with 10:1 step down turns ratios have been designed, tested at 10 kV, 500 kA, installed and have now been operating for several months in the ZT-40 RFP experiment at Los Alamos. The total leakage inductance for these three turn secondary transformers referred to the secondary has been measured at 9 nH for the larger transformer and 8 nH for the smaller transformer. Since these transformers were designed for use with a load having relatively high d.c. resistance, the d.c. resistance of aluminum windings was acceptable.

The electrical conceptual design for another application has been done with the following criteria met.

	value	units
volt-seconds rating	2.0	volt-seconds
secondary resistance	1.5×10^{-6}	ohms
secondary leakage inductance	12.6×10^{-9}	henries
penetration time	82×10^{-6}	seconds
primary voltage pulse	8×10^3	volts
secondary current	0.83×10^6	amps

Six of these transformers are to be used with their secondaries in parallel thus providing a net

secondary resistance of 0.25×10^{-6} ohms
 secondary leakage inductance of 2.1×10^{-9} henries
 secondary current of 5×10^6 amps .

Introduction

A Parallel-Plate Windings Transformer¹ refers to a transformer whose windings are fabricated from aluminum or copper sheet metal plates that are stacked around the core with the plane of each turn physically in parallel with the plane of every other turn on that same core leg (see Fig. 1). The advantages to this type of construction can be low leakage inductance, low D. C. resistance, and high current capability with large volt-second ratings. High voltage applications can be met if the proper insulation is chosen. The primary disadvantages are size and weight. Also the transformer capacitance is relatively** high.

The transformer discussed assumes a c-core mounted vertically with winding modules around both vertical legs.

*Work performed under the auspices of the U.S. Department of Energy.

**Compared to a wire windings transformer.

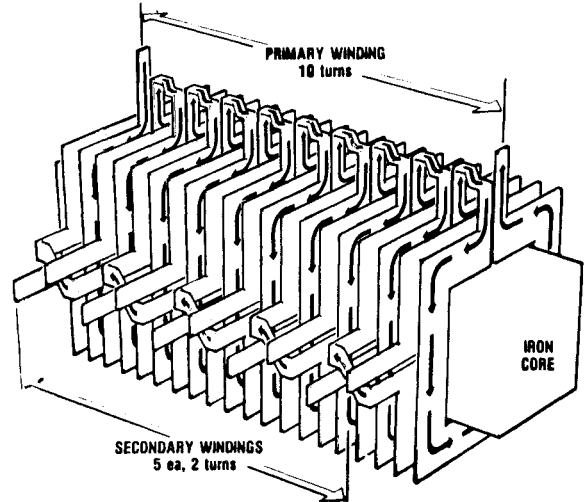

Figure 1

Electrical ConsiderationsCore

The core material should be selected based upon the application criteria to be met. In applications where a large volt-second rating is required a three percent silicon-iron core has been used. Parameters to be considered are:

volt-second rating
 weight
 characteristic property
 cross-sectional area
 window size required

For the three percent silicon-iron core these parameter values are:

volt-seconds/cm ²	3.2×10^{-4} (with bias)
weight	437 lbs. per cubic foot
characteristic property	grain oriented laminations of 0.012" thickness

The cross sectional area required in cm² is equal to the volt-seconds required divided by 3.2×10^{-4} times the number of turns per secondary windings,

$$A = \frac{v-s \text{ required}}{3.2 \times 10^{-4} N_{st}} .$$

Report Documentation Page

Form Approved
OMB No. 0704-0188

Public reporting burden for the collection of information is estimated to average 1 hour per response, including the time for reviewing instructions, searching existing data sources, gathering and maintaining the data needed, and completing and reviewing the collection of information. Send comments regarding this burden estimate or any other aspect of this collection of information, including suggestions for reducing this burden, to Washington Headquarters Services, Directorate for Information Operations and Reports, 1215 Jefferson Davis Highway, Suite 1204, Arlington VA 22202-4302. Respondents should be aware that notwithstanding any other provision of law, no person shall be subject to a penalty for failing to comply with a collection of information if it does not display a currently valid OMB control number.

1. REPORT DATE JUN 1981	2. REPORT TYPE N/A	3. DATES COVERED -			
4. TITLE AND SUBTITLE Parallel-Plate Windings Transformer For Pulsed Power Applications		5a. CONTRACT NUMBER			
		5b. GRANT NUMBER			
		5c. PROGRAM ELEMENT NUMBER			
6. AUTHOR(S)		5d. PROJECT NUMBER			
		5e. TASK NUMBER			
		5f. WORK UNIT NUMBER			
7. PERFORMING ORGANIZATION NAME(S) AND ADDRESS(ES) Los Alamos National Laboratory Mail Stop 644 Los Alamos, New Mexico 87545		8. PERFORMING ORGANIZATION REPORT NUMBER			
9. SPONSORING/MONITORING AGENCY NAME(S) AND ADDRESS(ES)		10. SPONSOR/MONITOR'S ACRONYM(S)			
		11. SPONSOR/MONITOR'S REPORT NUMBER(S)			
12. DISTRIBUTION/AVAILABILITY STATEMENT Approved for public release, distribution unlimited					
13. SUPPLEMENTARY NOTES See also ADM002371. 2013 IEEE Pulsed Power Conference, Digest of Technical Papers 1976-2013, and Abstracts of the 2013 IEEE International Conference on Plasma Science. Held in San Francisco, CA on 16-21 June 2013. U.S. Government or Federal Purpose Rights License.					
14. ABSTRACT					
15. SUBJECT TERMS					
16. SECURITY CLASSIFICATION OF:			17. LIMITATION OF ABSTRACT SAR	18. NUMBER OF PAGES 3	19a. NAME OF RESPONSIBLE PERSON
a. REPORT unclassified	b. ABSTRACT unclassified	c. THIS PAGE unclassified			

The window of a transformer is the opening between the core laminations through which the windings pass. The window size, height and width of a transformer is determined by consideration of several factors, namely: space available, core and frame size, number and thickness of turns required, and insulation space requirements.

Windings

Those parameters determining what material should be used for windings are:

- d.c. resistance*
- weight
- cost

The resistivity of aluminum is 2.824×10^{-8} ohm meters. For copper it is 1.724×10^{-8} ohm meters. Therefore when considering whether to use aluminum or copper for the windings it is necessary to realize that if d.c. resistance is of primary importance that it will require $2.824/1.724 = 1.64$ times the windings volume to achieve the same d.c. resistance with aluminum as with copper.

The weight of aluminum is 165 lbs. per cubic foot. The weight of copper is 556 lbs. per cubic foot.

The cost factor is figured based on the fact that aluminum and copper cost about the same per pound. Therefore to achieve the same d.c. resistance the cost ratio for copper versus aluminum is $(556/165) \times (1/1.64) = 2.06$. (This of course does not consider any additional core cost which would be required in providing space to place 1.64 times as much aluminum as copper.)

Winding size is influenced by design criteria such as:

- maximum leakage inductance permitted
- maximum d.c. resistance permitted
- penetration time permitted

Low leakage inductance is obtained by closely coupling the primary and secondary windings and designing a low leakage flux path. The number of primary and secondary turns is identical since the primary and secondary turns are alternately interleaved (see Fig. 2).

Leakage inductance referred to the secondary is calculated as follows. The leakage per secondary turn is approximately

$$L_{sc} = \mu_0 \left[\frac{d_T}{W_T} \cdot \ell_T + \frac{d_I}{W_I} \cdot \ell_I \right] \text{ henries ,}$$

- where
- $\mu_0 = 4\pi \times 10^{-7}$
 - d_T = insulation thickness between turns
 - W_T = winding width

*Affects number of turns required in parallel to meet a given specification and therefore space available must be considered.

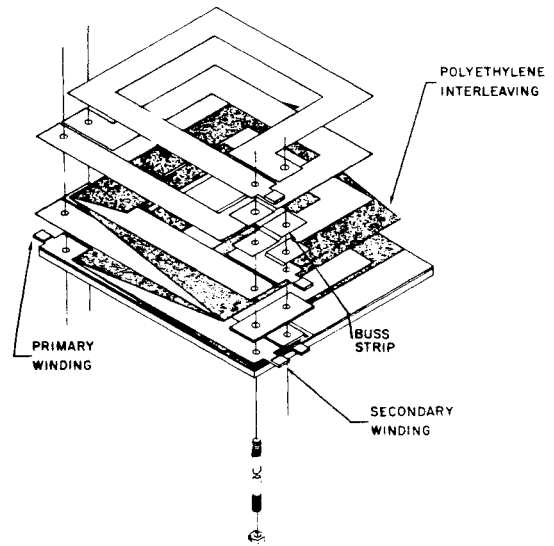

Figure 2

- ℓ_T = mean winding length
- d_I = interconnection separation**
- W_I = interconnection width
- ℓ_I = interconnection length
- (all dimensions are in meters)

The total transformer leakage inductance referred to the secondary is

$$L_T = \frac{N_{ST} \cdot L_{sc}}{N_M \cdot N_{SM}} + \frac{N_{PT} \cdot L_{sc}}{N_M \cdot N^2} \text{ henries ,}$$

where

- N_{ST} = number of secondary turns per secondary winding
- N_M = number of winding modules per core
- N_{SM} = number of secondary windings per module
- N_{PT} = number of primary turns per primary winding
- N = turns ratio

In a pulse transformer it is sometimes necessary that the skin penetration time through the winding material be less than the rise time of the pulse to be delivered. The skin penetration time for a specific thickness of material is given by

$$t = \frac{\mu_r \mu_0 \delta^2}{2\rho} ,$$

where

- $\mu_r = 1.0$ (for both copper and aluminum)
- $\mu_0 = 4\pi \times 10^{-7}$
- δ = material thickness in meters

**Interconnection separation is the insulation separation between one turn to turn interconnection piece and the next turn to turn interconnection piece.

ρ = resistivity of the winding material in ohm meters

Insulation

The insulation between turns must be capable of sufficient voltage hold-off and yet thin enough to be flexible and permit the leakage inductance to be low enough for the particular design requirement. Thus materials which seem to be best fit these requirements are low density polyethylene and mylar. In order to meet both the flexibility and voltage hold-off requirements it is best to use multiple sheets (a minimum of three). In other words, if a thickness of 0.03" is desired it would be better to have three 0.01" sheets or six 0.005" sheets than one 0.03" sheet. This is because of the possibility of pin holes in the insulation and the better flexibility of multiple thinner sheets than one thick sheet. The need for flexibility will be shown in the mechanical design section.

Transformers using this type of insulation between turns situated in air pulsed to 10 kV are presently in use. It is recommended that for use above 10 kV an oil or SF₆ environment be considered.

The insulation between turns does not insulate the windings from the transformer core. Both an air gap between the turns and the core and several wraps of sufficient thickness insulation around the core provides the necessary voltage hold-off capability. Also a window frame shaped piece of polyethylene can be used to help winding alignment relative to the transformer core (see Fig. 3).

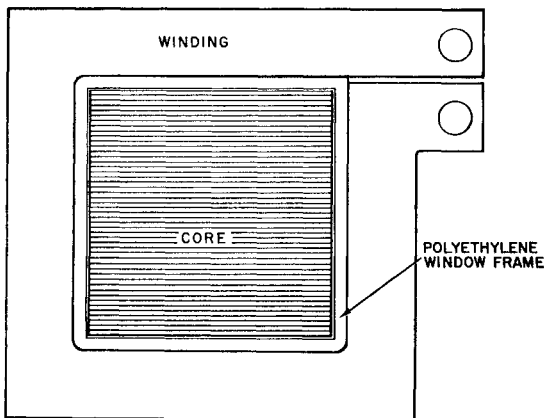

Figure 3

Mechanical Design

The two primary considerations for the mechanical design must be to minimize the leakage inductance and the d.c. resistance in order to meet the electrical design criteria. Additional items to be considered are physical size, support strength, methods of connecting the primary to its source, methods of connecting the secondary to the load, voltage hold-off requirements, ease of turns ratio changes, and ease of maintenance.

In order to minimize the leakage inductance and the d.c. resistance, careful thought must be given to the interconnections between turns. Also leakage inductance is minimized by keeping the spacing between turns as small as possible. Since the insulation

between turns is interleaved in a serpentine fashion flexibility is required (see Fig. 2).

Primary and secondary circuit connections can be made to the transformer either with the use of a header (described in Ref. 2 and illustrated in Fig. 4) where cable connections are required, or by direct connection to the winding module where transmission lines are required.

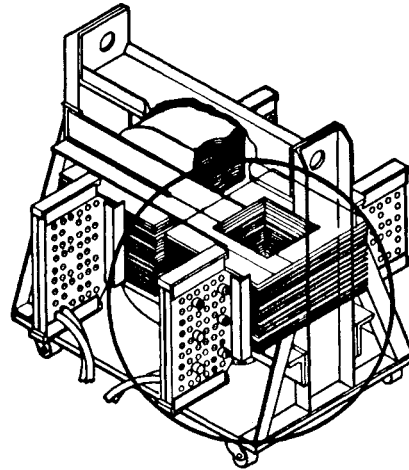

Figure 4

References

1. S. Kitagawa and K. Hirano, "Fast Power 'Crowbar' System Using a Current Transformer with Extremely Low Leakage Inductance," *Rev. Sci. Instrum.* **45** 7, 962, (1974).
2. R. Buck, J. Galbraith, W. Nunnally, "Low Leakage, High Current Power Crowbar Transformer," *Proceedings of the 8th Symposium on Engineering Problems in Fusion Research*, Vol. 3, p. 1205 (1979).