

10.1  
INVITED

SUB-OHM COAXIAL PULSE GENERATORS,  
BLACKJACK 3, 4 AND 5

A. R. Miller  
Maxwell Laboratories, Inc.  
8835 Balboa Avenue  
San Diego CA 92132

The absence of published information on the BLACKJACK machines prompts me to review their development during the past decade. This effort has produced a series of terawatt level, low impedance coaxial pulse generators. It is worthwhile to catalogue them here and to present solutions to various design problems. In addition, I will briefly discuss our present machine development and point out some of the present problems in this technology.

INTRODUCTION

As should be obvious by now, the purpose of these machines is Nuclear Weapons Effects Simulation. A typical pulser is comprised of; a low power, albeit energetic, primary energy storage unit, a concatenation of pulseforming lines and switches which effect power gain through waveform compression and a vacuum coupler, through which the energy flows to whatever radiation producing load is in vogue. Present day pulsers are large systems where typical dimensions are measured in meters and where a wide variety of pulsed power problems are encountered.

There have been marked trends in pulser development since the 1960s. These trends have been driven by a transition from electron beam bremsstrahlung — to plasma radiator type loads. This has necessitated a change from high impedance to low impedance pulsers, where, instead of high voltage, we are interested in high current. This change has been facilitated by using water, rather than oil, as a dielectric in the transient energy storage stages.

The use of either dielectric entails the solution of a variety of problems, not the least of which is dielectric breakdown — its avoidance in regions where energy is stored — and its promotion where and when energy is switched.<sup>1</sup>

Much of the basis for machine design has been provided by the pioneering work of the group under Charlie Martin at the Atomic Weapons Research Establishment in the United Kingdom.<sup>2</sup> Then and now, paper after paper cite their work. Early work outside the AWRE at places like Sandia National Laboratories, Naval Research Laboratories, EG&C Bedford, Physics International and Cornell resulted in the production of a large variety of machines, establishing the trend shown in Figure 1.<sup>3,4,5,6,7,18</sup> Only coaxial machines are shown. The inclusion of two Blumlein type, high impedance, oil dielectric machines provides a comparison with the water based technology discussed here. The point representing Aurora is for one of the four modules.

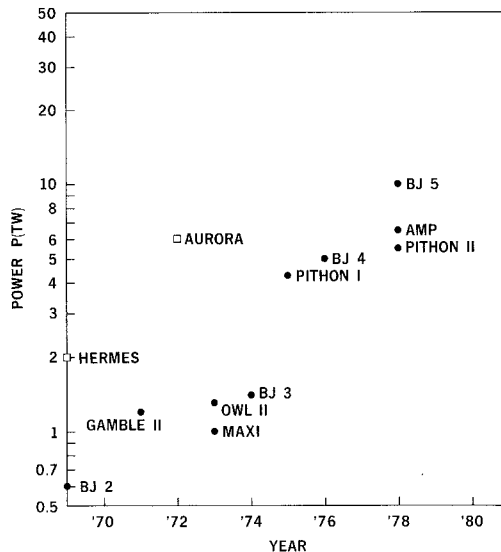

Figure 1. Machine output power vs year of commissioning for a sampling of coaxial machines, (□ oil, ● water, dielectrics).

The earliest machines of any noticeable power level had output impedances of a few ohms and delivered some tens of kJs — large electrode areas meant  $10^3$  to  $10^4$  cm<sup>2</sup>. A typical early approach to lower impedance, which was motivated by switch inductance limited risetime, was to switch a pulseforming line of relatively high impedance into a tapered line type transformer.<sup>5</sup> This provided the necessary matching (to low impedance loads) without compromising pulse risetime. The usefulness of this approach was limited by the very high voltages required to get more energy into a predetermined pulse length.

To proceed further, a number of basic issues had to be addressed.

- High power operation results from the highest density energy storage. Energy transfer, or power flow, through the pulser ultimately converges from very large dimensions down to a few cm at the load. The limits of this power convergence are determined by breakdown. Thus, the breakdown limits of a water dielectric system with large electrode areas must be determined.
- The inductance of switches for low impedance pulselines had to be reduced if pulse risetimes were to be shorter than pulse widths.
- Accurate predictive capabilities had to be developed, along with models of pulser parameters, if expensive mistakes were to be avoided.

# Report Documentation Page

*Form Approved*  
*OMB No. 0704-0188*

Public reporting burden for the collection of information is estimated to average 1 hour per response, including the time for reviewing instructions, searching existing data sources, gathering and maintaining the data needed, and completing and reviewing the collection of information. Send comments regarding this burden estimate or any other aspect of this collection of information, including suggestions for reducing this burden, to Washington Headquarters Services, Directorate for Information Operations and Reports, 1215 Jefferson Davis Highway, Suite 1204, Arlington VA 22202-4302. Respondents should be aware that notwithstanding any other provision of law, no person shall be subject to a penalty for failing to comply with a collection of information if it does not display a currently valid OMB control number.

1. REPORT DATE <b>JUN 1981</b>	2. REPORT TYPE <b>N/A</b>	3. DATES COVERED <b>-</b>	
4. TITLE AND SUBTITLE <b>Sub-Ohm Coaxial Pulse Generators, Blackjack 3, 4 And 5</b>		5a. CONTRACT NUMBER	
		5b. GRANT NUMBER	
		5c. PROGRAM ELEMENT NUMBER	
6. AUTHOR(S)		5d. PROJECT NUMBER	
		5e. TASK NUMBER	
		5f. WORK UNIT NUMBER	
7. PERFORMING ORGANIZATION NAME(S) AND ADDRESS(ES) <b>Maxwell Laboratories, Inc. 8835 Balboa Avenue San Diego CA 92132</b>		8. PERFORMING ORGANIZATION REPORT NUMBER	
9. SPONSORING/MONITORING AGENCY NAME(S) AND ADDRESS(ES)		10. SPONSOR/MONITOR'S ACRONYM(S)	
		11. SPONSOR/MONITOR'S REPORT NUMBER(S)	
12. DISTRIBUTION/AVAILABILITY STATEMENT <b>Approved for public release, distribution unlimited</b>			
13. SUPPLEMENTARY NOTES <b>See also ADM002371. 2013 IEEE Pulsed Power Conference, Digest of Technical Papers 1976-2013, and Abstracts of the 2013 IEEE International Conference on Plasma Science. Held in San Francisco, CA on 16-21 June 2013. U.S. Government or Federal Purpose Rights License.</b>			
14. ABSTRACT			
15. SUBJECT TERMS			
16. SECURITY CLASSIFICATION OF:			17. LIMITATION OF ABSTRACT
a. REPORT <b>unclassified</b>	b. ABSTRACT <b>unclassified</b>	c. THIS PAGE <b>unclassified</b>	<b>SAR</b>
			18. NUMBER OF PAGES <b>6</b>
			19a. NAME OF RESPONSIBLE PERSON

- The sometimes conflicting mechanical and electrical requirements had to be resolved by innovative design of large structures.

These issues dictated the overall structure of our machine development program at Maxwell and they are still relevant today.

### BLACKJACK PULSERS

One of the earliest pulsers produced at Maxwell was BLACKJACK 2 (Figure 2). This machine had an output impedance of 1.5 ohms and delivered almost 30 kJ in an electron beam. It featured plastic diaphragms to separate Marx oil from the water, and a pulseforming line charged directly by a Marx generator to 2 MV. Output switching was by four command triggered, gas dielectric, trigatrons in parallel. These had graded plastic envelopes to separate SF<sub>6</sub> at

100 psi from the water. The first to last closure scatter of these switches was characterized by a  $\sigma$  of 5 ns. An effective inductance of 80 nH gave 30 ns risetimes. However, it was a bomb — occasional tracks on the switches would liberate the stored pneumatic energy and most of the water. Additionally, further inductance reduction was limited by the small number of switches which could be put in parallel. This, and triggering complexity, motivated our change of emphasis to switching directly in water.

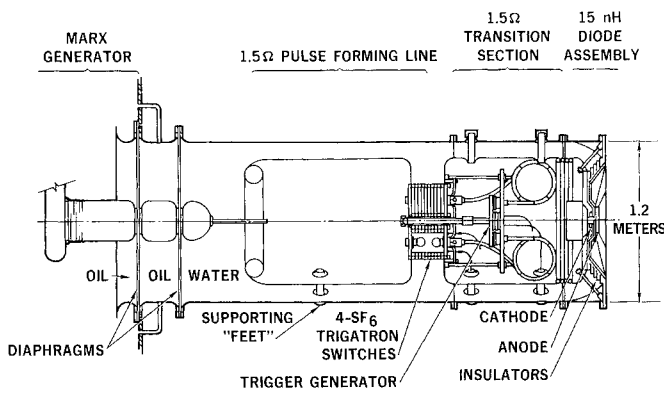

Figure 2. BLACKJACK 2, 1.5  $\Omega$  electron beam accelerator. Output power, 0.6 TW.

During the period between BLACKJACK 2 and 3, much research was done on; large area water breakdown, breakdown of plastic interfaces, and multichannel breakdown. The results of these studies contributed greatly to the design of our later machines.

The water breakdown results are summarized in Figure 3. A part of these studies was motivated by reports from Russia that pressurization would suppress breakdown in slowly charged systems.<sup>9</sup> As can be seen, there is an effect due to pressurization even at the short times of interest to us, however, that effect essentially disappears for large areas. Note that these are modal values of the breakdown voltage distributions and are for a common electrode surface; sandblasted or glassbead blasted stainless steel. The straight line is a limit predicted by the empirical relationship originating at the AWRE.<sup>10</sup> The divergence of the one atmosphere data from this breakdown criteria at small areas is worth considering,

but we see that, for sizes larger than BLACKJACK 2, the scaling first noted at the AWRE applies. This area scaling raises an important question which is yet to be resolved — whether the breakdown strength scales towards zero as machines, or groups of machines, get arbitrarily large, or whether it stops at some usable limit. Our conclusion, based upon the width of observed breakdown distributions and the desirability of obtaining further data for large electrode areas, was to design the next machine (BLACKJACK 3) to operate at the breakdown limit.

The interface studies showed that, with proper grading, plastic surfaces could be as strong as the water. Applications of this will be seen later.

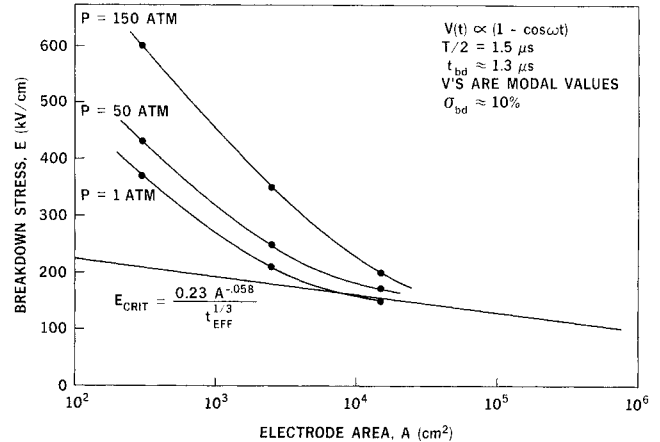

Figure 3. Variation of water breakdown stress with pressure and area.

During the period between BLACKJACK 2 and 3 we also developed multichannel switching. In this we were influenced by earlier exploratory work at NRL on the Gamble II machine.<sup>11</sup>

Consider a single electrode set and an applied voltage waveform as shown in Figure 4. Breakdown is observed to occur at various levels producing a wide distribution in breakdown times as shown. If we enhance the field at the tip of the smaller electrode the distribution is observed to narrow, and typically  $\sigma$  is found to be  $\approx 3$  percent of the  $t = 0$  to breakdown time. If we then place  $N$  of these electrode sets in parallel they will operate independently and switch in parallel if the criteria shown is satisfied. A simple analysis gives the probability of 80 percent or more of the total being closed as 0.90 if the criteria is met. What is required is that the electromagnetic wave transit time, or isolation time, between switch sites be about the width of the distribution. This is relatively easy to achieve in water. Additionally, it is necessary that the electrodes survive the mechanical shock produced by breakdown. The advantage of this scheme is that it can be utilized to produce low inductance switches in pulsers of large dimensions. Instead of locating a single switch on the axis of a pulser, with a large inductance resulting from the current convergence, the sites can be distributed around the perimeter of a given coaxial stage. One should distinguish between this preselected site scheme and the continuous edge-plane multichannel switches developed at SNL.<sup>12</sup>

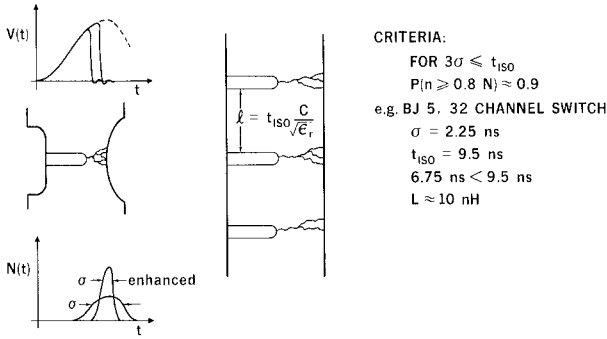

Figure 4. A rationale for multisite, multichannel water switches.

The above notions were first used in 1974 on BLACKJACK 3 (Figure 5). This machine delivers about 40 kJ in a 60 ns pulse. Peak output power is 1.3 TW at a peak current slightly over 1 MA. This was the first pulser to operate on a routine basis with a twelve channel, self-closing, multi-site, water dielectric output switch. Inductance was 20 nH at 2 MV. The single channel transfer switch is also a self-closing water switch with an inductance of 150 nH at 2.25 MV. The transfer capacitor is needed to charge the pulseforming line rapidly enough for proper operation of the output switch. Note also that what is shown here — the transfer capacitor, pulseforming line, switches, etc., are all placed within a BLACKJACK 2 envelope. These improvements doubled the power without an increase in size. In addition, note the transfer capacitor is cantilevered from the diaphragm assembly, and the diaphragms now see higher electrical stresses than in BLACKJACK 2, almost as high as the water.

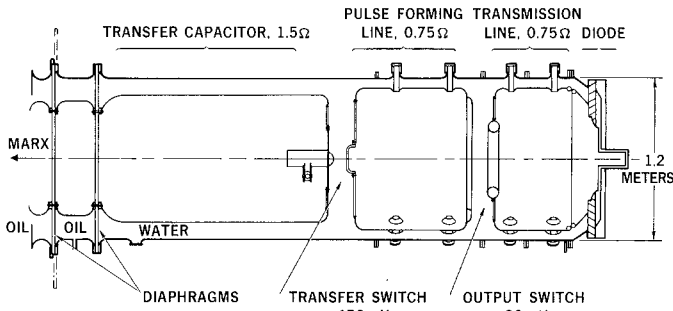

Figure 5.  $3/4 \Omega$ , 1.3 TW BLACKJACK 3 pulseline cross section.

Maximum electrical design stress levels in BLACKJACK 3 were 100 percent of those given by the water breakdown criteria whereas BLACKJACK 2 was designed to 70 percent of breakdown. Breakdowns not associated with interfaces were not observed during the pulse. There were, however, breakdowns of the plastic posts supporting the pulseline and transmission line. This machine is still in regular use at power levels up to 1 TW.

An early attempt at modeling an equivalent circuit for BLACKJACK 3 is shown in Figure 6. This was based upon experiments and simple calculations. It was used with our earliest transmission line analysis computer codes to predict gross behavior. Agreement was only approximate as a result of the omission of details later found to be very important (e.g., switch losses and stage end effects).

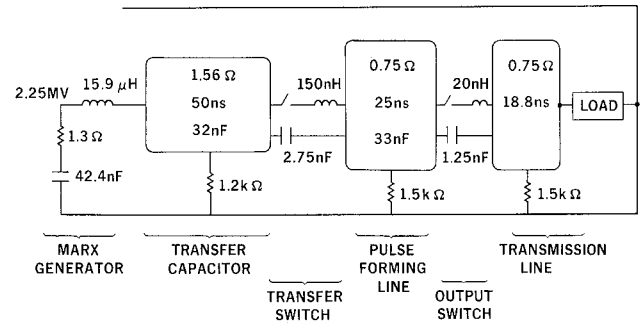

Figure 6. Electrical model of BLACKJACK 3.

All of the machines in the BLACKJACK series have been technology experiments in addition to supporting radiation source development. The results from BLACKJACK 3 provided the basis for BLACKJACK 4.<sup>13</sup> Briefly, BLACKJACK 4 met its design goal of a 5 TW output power level. To do this it used multichannel switches and high dielectric stresses. BLACKJACK 4 is now reconfigured to BLACKJACK 5, the following discussion will cover that machine.

BLACKJACK 5 is four meters in diameter and about ten meters long. It is assembled in modular sections with plastic diaphragms interposed at the flanges to support internal components. The schematic view in Figure 7 shows this structure in cross section and illustrates the number of stages used to produce power gain. These stages are interconnected by self-closing water switches. Between the first and second stage is a single channel switch. The remaining stages are connected by 6, 16 and 32 channel switches with respective inductances of 80, 30, and 10 nH. Peak stage voltages at the 10 TW level are 5.7, 5.2, 4.9 and 3.9 MV with charge times per stage of 1700, 500, 170 and 70 ns, respectively. The largest electrode areas are  $>0.5 \times 10^6 \text{ cm}^2$ . Two design features are implicit in this construction. The first is the large annular plastic diaphragms which support and insulate the stages. These operate at essentially the same electrical stress as the water. This modular construction permitted expansion from BLACKJACK 4 to BLACKJACK 5 through the addition of a stage and slight alterations of impedance. The second point is that pulse width variations are obtained by closing selected switches prior to operation. This can result in the output pulse being produced by either a 50, a 100, or a 150 ns pulseforming line. For example: closure of the 32-channel switch connects the 25 ns PFL as a part of the transmission line and the 16-channel switch then acts as an output switch for the 50 ns IPFL. The times shown are one way transit times. This flexibility was called for in optimizing load design and has proven useful.

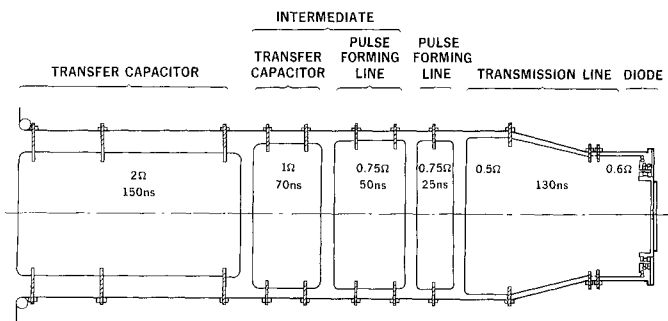

Figure 7. Cross sectional view of the BLACKJACK 5 pulseline.

Interface breakdown was mentioned earlier. We had breakdowns of the end diaphragm on the transfer capacitor at about 5 MV. All of these breakdowns were on the same surface and started from the center conductor. High resolution potential plots of this region showed a relaxation in the potential distribution through the diaphragm leading to stress enhancement at the inner corner as shown in Figure 8. The addition of a grading ring near the enhancement reshaped the fields and eliminated the breakdown.

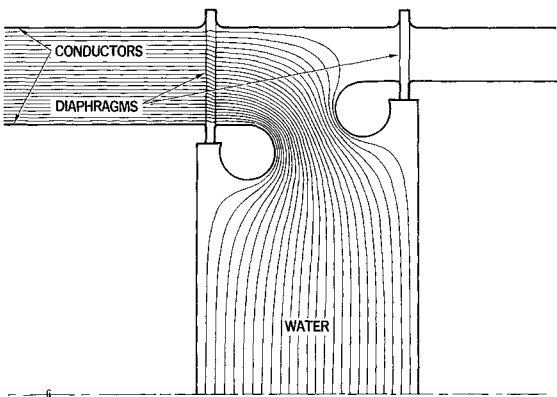

Figure 8. Equipotential distribution at end of transfer capacitor, showing enhancement at interface of diaphragm with inner conductor.

Figure 9 shows before and after diaphragm stresses and reflects the conservatism, or lack of it, in certain designs.

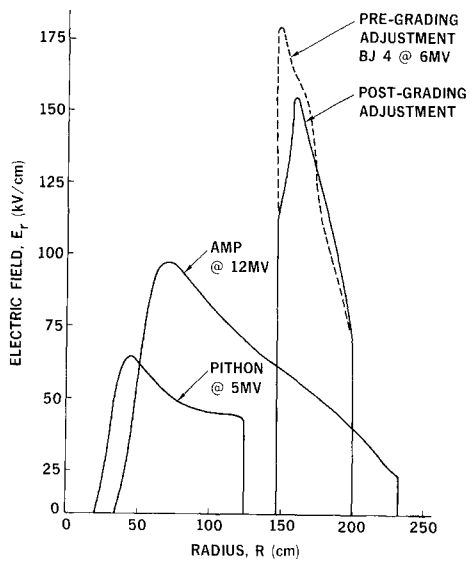

Figure 9. Pulseline diaphragm stress for BLACKJACK 4 and BLACKJACK 5 transfer capacitor, (AMP and Pithon diaphragm stresses included for comparison).

An adjunct to the potential plotting routine permits additional analysis of interstage regions. As shown in Figure 10, electric field lines break up the space into regions of equal capacitance. From this we can determine impedances and e-m wave transit times to produce the equivalent circuit shown in Figure 11. These are the first two sections of BLACKJACK 5. The modeling of the switch and interstage region is shown. Switch losses are accounted for by a resistance value which is essentially what would be calculated from one of Charlie's recent notes,<sup>14</sup> and is somewhat less than that determined by Spence, et.al.,<sup>15</sup> in a similar configuration. Performance of the complete model closely reflects reality without invoking the extraordinarily high resistances proposed by other investigators.<sup>16,17</sup>

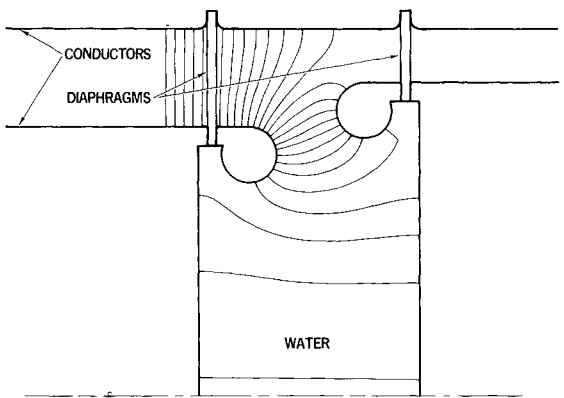

Figure 10. Electric field distribution at end of transfer capacitor.

PRESENT MACHINE DEVELOPMENT

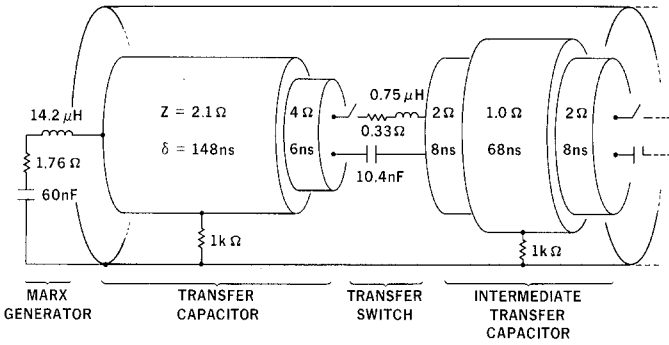

Figure 11. Part of BLACKJACK 5 pulseline model.

The Marx generator for this pulser is actually three units in parallel with a total energy storage capacity of 2 MJ. Each of the three utilize 70 capacitor stages connected by spark gaps in a configuration producing hybrid triggering.<sup>4</sup> Triggering is initiated by a smaller 1 MV Marx generator. Total inductance is 14 μH and parallel operation is uneventful. The entire array is conventionally supported against gravity by plastic straps in an oil tank.

The scaling of BLACKJACK 5 output power with Marx energy input is shown in Figure 12. Maximum pulser output current for driving imploding plasma loads is >5 MA and di/dt's of approximately 10<sup>14</sup> A/s are achieved. Essentially the same power is achieved in both 50 and 100 ns modes with slight differences in delivery energy, a result which is due, in part, to the load.

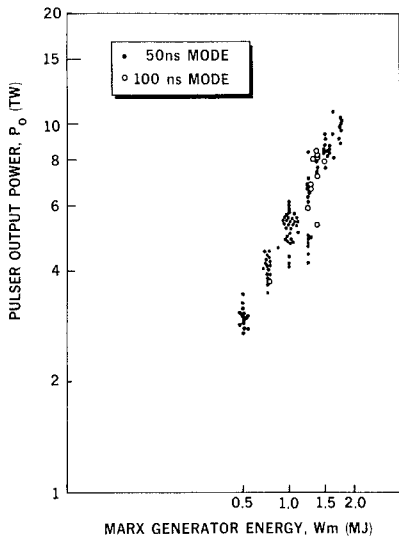

Figure 12. Scaling of BLACKJACK 5 output power vs Marx energy.

The above is a brief review of the DNA sponsored R&D at Maxwell for the past ten years — and brings us to the present machine development effort. The latest pulser design is shown in Figure 13 and is called BLACKJACK 5' (5 prime). This is a bolt on modification of the existing BLACKJACK 5 pulser and is intended to demonstrate "Convoluted Power" flow. By way of explanation of this terminology, notice that BLACKJACK 5 is very inefficient volumetrically. One can, in fact, place an entire pulser inside the active portion of the coax. This is partially what has been designed and consists of a dual pulseforming line, a dual transmission line and a double-back to back-version of the existing BLACKJACK 5 diode.

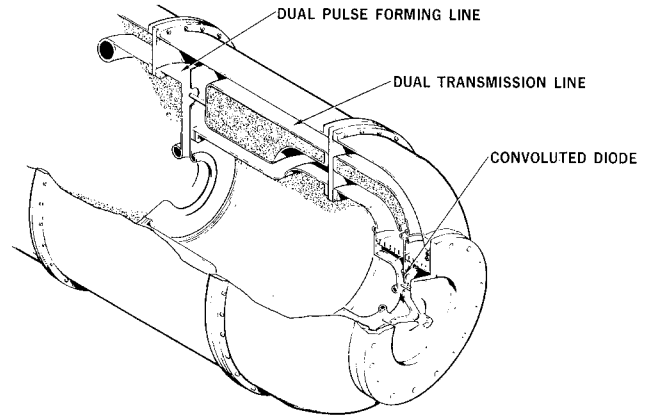

Figure 13. BLACKJACK 5', low impedance modification of BLACKJACK 5.

The preexisting PFL has been shortened slightly and a radial transmission line added at the switch end. This reduces the impedance of this section without increasing the pulse length, and also increases energy storage capacity, providing a better match to the previous stage. In addition, this helps match the PFL to the output. Switching is by multichannel switches through a ground plane shield which is also<sup>19</sup> the ground conductor for the radial line. This configuration provides the initial division, or convolution, of the power flow into the dual output Tls. Output impedance is about 0.3 ohms. As shown, the final power flow convergence is accomplished in the diode, in vacuum, through "post hole convolutes".

The important issue here is to show that this configuration will work and to determine optimum configurations for the final convolution, this being a trade off between inductance and breakdown.

The importance of this concept is that it is a viable approach to power levels above 25 TW from a single module. It is essentially two pulsers in parallel where internal synchronization problems are solved by virtue of sharing common switches. External synchronization is a separate issue and is listed below with a brief summary of some of the current problems in this technology.

- Precise synchronization with external events is a potential problem with self closing water switches — recent results with laser triggered water switching<sup>20</sup> offers a solution here.
- Internal timing anomalies in larger machines could produce azimuthal asymmetries in the pulse which may cause load instabilities — this is also possible in large, modular, radial machines.
- Better understanding of switch physics would quantify losses as a function of design and lead to better designs.
- The problem of switch generated shock and the impulsive loading of machine structures complicates their design — but not impossibly so.
- Machine structural fatigue life is an issue, even at low shot rates, as the operating power levels are increased.
- The large area breakdown scaling was mentioned earlier and is relevant if two larger BLACKJACK 5' type machines are operated in parallel.
- Power convergence is limited by the breakdown level of whatever dielectric is used — raise that level — by whatever means, and the power is raised.

#### ACKNOWLEDGEMENT

These efforts were funded by a series of DNA contracts, the latest of which is DNA001-79-C-0019. While I have tried to acknowledge the influence of others in the field, space prohibits a complete listing (which would read from Abramyan to Zucker). I would, however, like to credit my co-workers at Maxwell Laboratories, Inc., as well as Jonathan Farber, DNA, who for many years has provided insight and guidance to these programs. Particular mention should be made of the work of J. Shannon in designing the vacuum diodes for these machines, without these, the issue would be moot.

#### REFERENCES

1. I. Smith, "Short-Pulse Insulation and Breakdown: A Phenomenological Review," Conference on Electrical Insulation and Dielectric Phenomena, Pocono, PA (October 1979)
2. See for example; AFWL Pulsed Electrical Power Dielectric Strength Notes, AFWL TR 73-167, Vol 1
3. T. H. Martin, K. R. Prestwich, D. L. Johnson, "Summary of the Hermes Flash X-Ray Program," SC-RR-69-421, (October 1969)
4. B. Bernstein, I. Smith, "Aurora, an Electron Accelerator," IEEE Trans. Nucl. Sci. NS-20 (1973)
5. J. D. Shipman, Jr., "Final Electrical Design Report on the Gamble II Pulse Generator," NRL Memorandum Report 2212 (March 1971)
6. G. B. Frazier, "Owl-II, pulsed-electron-beam-generator," J. Vac. Sci. Tech., Vol 12, No. 6 (Nov/Dec 1975)
7. C. B. Dobbie, V. Fargo, A. C. Kolb, P. Korn, D. A. Phelps, A. Ramrus, "A High Current Relativistic Electron Beam Accelerator for Fusion Applications," Proc. 1st Topical Meeting on Tech. of Cont. Nuc. Fusion, Vol. II (April 1974)
8. D. Markins, "Command Triggering of Synchronized Megavolt Pulse Generators," IEEE Trans, Nucl. Sci. Vol NS-18, No. 4 (August 1971)
9. E. A. Abramyan, et al, "Megavolt Energy Intensifier," Doklady, Tech. Phys. Vol 201, No. 1 (1971)
10. R. A. Eilbert, W. N. Lupton, "Extrapolation of AWRE Breakdown Data," NRL Internal Report
11. J. K. Burton, D. Conte, W. H. Lupton, J. D. Shipman, Jr., I. M. Vitkovitsky, "Multiple Channel Switching in Water Dielectric Pulse Generators," IEEE Nuc. & Plasma Sci. (November 1973)
12. J. P. Van Devender and T. H. Martin, "Untriggered Water Switching," IEEE Trans on Nuc. Sci., Vol NS-22, No. 3 (June 1975)
13. P. Korn, A. R. Miller, "BLACKJACK 4; A Multi-terawatt Pulse Power System," Proc. of Pulsed Power Systems Workshop, Naval Surface Weapons Center, White Oak Laboratory, Silver Springs, MD (September 1976)
14. J. C. Martin, "Some Ill Considered Thoughts on the Resistive Phase of Water Spark Channels," Informal Note (e.c. 1978)
15. P. W. Spence, Y. G. Chen, G. B. Frazier, H. Calvin "Inductance and Resistance Characteristics of Single-Site Untriggered Water Switches in Water Transfer Capacitor Circuits," IEEE, 2nd Int. Pulsed Power Conf., Lubbock TX (June 1979)
16. J. D. Shipman Jr., "A Study of Power and Energy in the Aurora Modification Project," NRL Memorandum Report 4281, (July 1980)
17. F. J. Sazama, V. L. Kenyon III, "A Streamer Model for High Voltage Water Switches," 2nd IEEE Int. Pulsed Power Conf., Lubbock, TX (June 1979)
18. G. B. Frazier, "Python - A Low Impedance Super Power Generator," Proc. of Pulsed Power Systems Workshop, Naval Surface Weapons Center, White Oak Laboratory, Silver Springs, MD (September 1976)
19. D. L. Johnson, J. P. VanDevender, T. H. Martin, "High Power Density Water Dielectric Switching," IEEE Trans. on Plasma Science, V. TP-8, #3, September 1980
20. D. Lischer, A. Ramrus, "Laser Initiated Conduction of an Overvolted Water Spark Gap," 3rd IEEE International Pulsed Power Conference, Albuquerque New Mexico, June 1981