

HOMOPOLAR GENERATOR CONCEPT FOR VERSATILE PULSED OUTPUT*

W. H. Lupton, R. D. Ford, D. Jenkins, and I. M. Vitkovitsky

Naval Research Laboratory
Washington, D. C. 20375Summary

A description of a pulse generator based on inductive storage energized by a self-excited homopolar generator (HPG) is presented. The proposed system uses separate inductors for energy storage and HPG excitation field. Parallel connection at the low-impedance HPG provides voltage isolation of the inductors and yet preserves mechanical-to-electrical conversion efficiency over a wide range of currents. At given stored energy, output current and voltage are determined by altering storage inductance and switch selection. To determine the maximum current output of given HPG design, experiments have been done to determine the current density capability of brush contacts at rotor rim speeds as high as 475 m/s.

Introduction

Inertial and inductive systems are capable of storing energy with a high energy density. With proper design they can be used for storage of very large energy levels within a reasonable size and therefore permit economical construction of large pulse power facilities. A pulsed power system¹ built at the Naval Research Laboratory uses inductive energy storage energized by a self-excited homopolar generator (HPG) with the primary inertial energy stored in the HPG rotors. The storage inductor has been energized with currents of up to 60 kA. However the voltage across it has been limited to 200 kV due to insulation. Accordingly power output from inductive storage is limited to 10^{10} Watts.

For many areas of interest higher power output is needed from the inductive storage system. It is thus desirable to operate the inductor with much greater voltages across it and to be able to energize it from the HPG with greater current output. One approach for modifying the NRL system for higher-voltage and higher power output was studied earlier.² That study concluded that the coil could be energized at 200 kA and insulated to permit output at a 1-MV level. However, it involved reconfiguration of the inertial storage system to operate inside a high-voltage, liquid-dielectric insulated coil. In this paper we explore an alternative circuit concept which requires an additional energy storage inductor connected to the HPG output in parallel with the excitation inductor. This approach requires no major modification of the excitation coil or relocation of the inertial storage. Furthermore, analysis of moving contact brush performance indicates that, due to the nature of the limit on current, this modification may be implemented without an increase in brush area.

Parallel Storage Concept

If a self-excited HPG has two separate inductors electrically connected in parallel to the rotating wheel voltage source, one can be used to provide the exciting field and the other can be used as energy storage for a pulsed power device. A representation of the electrical circuit of such a self-excited HPG is shown in Fig. 1. The series connected pair of counter-rotating disc generators supplies current to

both the excitation coil and storage coil. The excitation coil, represented schematically by the inductors at the top of the figure, is wrapped as a helix coaxial with the wheels, and provides a mutual inductance coupling between it and the disc generator. The storage coil is arranged to have minimal mutual coupling with the disc generator.

The HPG voltage is the product of wheel speed, v , and the flux through the wheel circuit. This flux is Mi_1 where M is the mutual inductance between the excitation coil and the wheel circuit. As shown in Fig. 1, this voltage is applied across both the excitation coil circuit (with inductance L_1 and

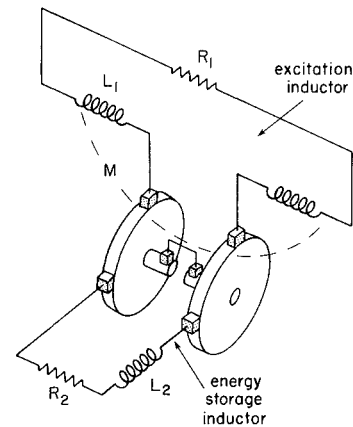

Fig. 1. Schematic circuit of self-excited HPG with parallel energy-storage inductor.

resistance R_1) and the storage coil circuit (with inductance L_2 and resistance R_2). The voltage equations are:

$$Mi_1 v = L_1 (di_1/dt) + R_1 i_1 \quad (1)$$

$$= L_2 (di_2/dt) + R_2 i_2 \quad (2)$$

The torque decelerating the HPG wheels is dependent on the total wheel current, $i_1 + i_2$, so the torque equation is:

$$2\pi I (dv/dt) = - (M/2\pi) i_1 (i_1 + i_2) \quad (3)$$

where I is the moment of inertia of the wheels.

In one case, where the time-constants of excitation and storage circuits are equal, the currents are simply related. This can be seen by writing the right-hand sides of (1) and (2) as:

*This work is supported by ONR.

Report Documentation Page

Form Approved
OMB No. 0704-0188

Public reporting burden for the collection of information is estimated to average 1 hour per response, including the time for reviewing instructions, searching existing data sources, gathering and maintaining the data needed, and completing and reviewing the collection of information. Send comments regarding this burden estimate or any other aspect of this collection of information, including suggestions for reducing this burden, to Washington Headquarters Services, Directorate for Information Operations and Reports, 1215 Jefferson Davis Highway, Suite 1204, Arlington VA 22202-4302. Respondents should be aware that notwithstanding any other provision of law, no person shall be subject to a penalty for failing to comply with a collection of information if it does not display a currently valid OMB control number.

1. REPORT DATE JUN 1981	2. REPORT TYPE N/A	3. DATES COVERED -			
4. TITLE AND SUBTITLE Homopolar Generator Concept For Versatile Pulsed Output		5a. CONTRACT NUMBER			
		5b. GRANT NUMBER			
		5c. PROGRAM ELEMENT NUMBER			
6. AUTHOR(S)		5d. PROJECT NUMBER			
		5e. TASK NUMBER			
		5f. WORK UNIT NUMBER			
7. PERFORMING ORGANIZATION NAME(S) AND ADDRESS(ES) Naval Research Laboratory, Washington, DC 20375		8. PERFORMING ORGANIZATION REPORT NUMBER			
9. SPONSORING/MONITORING AGENCY NAME(S) AND ADDRESS(ES)		10. SPONSOR/MONITOR'S ACRONYM(S)			
		11. SPONSOR/MONITOR'S REPORT NUMBER(S)			
12. DISTRIBUTION/AVAILABILITY STATEMENT Approved for public release, distribution unlimited					
13. SUPPLEMENTARY NOTES See also ADM002371. 2013 IEEE Pulsed Power Conference, Digest of Technical Papers 1976-2013, and Abstracts of the 2013 IEEE International Conference on Plasma Science. Held in San Francisco, CA on 16-21 June 2013. U.S. Government or Federal Purpose Rights License.					
14. ABSTRACT					
15. SUBJECT TERMS					
16. SECURITY CLASSIFICATION OF:			17. LIMITATION OF ABSTRACT SAR	18. NUMBER OF PAGES 4	19a. NAME OF RESPONSIBLE PERSON
a. REPORT unclassified	b. ABSTRACT unclassified	c. THIS PAGE unclassified			

$$\frac{d}{dt} (L_1 i_1) + \frac{R_1}{L_1} (L_1 i_1) = \frac{d}{dt} (L_2 i_2) + \frac{R_2}{L_2} (L_2 i_2)$$

If $R_1/L_1 = R_2/L_2$, then the above equation implies $L_1 i_1 = L_2 i_2$. In this case i_2 can be eliminated from (3) and the torque written as:

$$2\pi I(dv/dt) = - (M/2\pi) i_1^2 (1 + L_1/L_2) \quad (4)$$

If in addition, the voltage equation (1) is rewritten as

$$L_1(di_1/dt) = M i_1 (v - R_1/M) \quad (5)$$

then inductor currents and energies can be determined by a method similar to that used by Knoepfel³ in his treatment of the self-excited HPG. First, Eq. (4) is multiplied by $2\pi(v-R_1/M)$ and Eq. (5) is multiplied by a factor $(1 + L_1/L_2)i_1$, then the two resulting equations are added and easily integrated to give a constant of the motion:

$$(1+L_1/L_2)L_1 i_1^2/2 + 2\pi^2 I(v-R_1/M)^2 = C$$

This constant may be evaluated at the time of peak excitation current, $i_1 = i_{1m}$. This occurs when $di_1/dt = 0$ or, from Eq. (5), when $v = R_1/M$. Then, the constant of the motion is:

$$C = (1+L_1/L_2) L_1 i_{1m}^2/2$$

It may also be evaluated at the start of the discharge when wheel speed is v_o and currents are nearly zero, so that

$$C = 2\pi^2 I (v_o - R_1/M)^2$$

By equating these two expressions for C we can determine the peak magnetic energy transferred to the excitation coil, $W_1 = L_1 i_{1m}^2/2$. Since the initial mechanical energy stored in the wheels is $W_o = 2\pi^2 I v_o^2$, the result can be written in terms of efficiency of energy transfer to the excitation coil

$$\frac{W_1}{W_o} = \frac{L_2}{L_1+L_2} \frac{(v_o - R_1/M)^2}{v_o^2}$$

The relation between the two currents, $L_2 i_2 = L_1 i_1$, also implies $W_2 = W_1 (L_1/L_2)$ and

$$\frac{W_2}{W_o} = \frac{L_1}{L_1 + L_2} \frac{(v_o - R_1/M)^2}{v_o^2}$$

The analysis of this particular case, indicates that when $L_2 \ll L_1$ essentially all of the energy transferred from inertial to inductive storage goes into the storage coil. Further, this energy is independent of the value of L_2 (as long as that is small), so the output current level can be adjusted by selection of L_2 .

To consider cases other than those with equal time constants for both storage and excitation inductors, Equations (1), (2) and (3) can be integrated numerically to provide time-dependent currents and flywheel speed for specific generator parameters. With numerical analysis the equations can also be modified to include terms for brush voltage drops friction and other coupling. These more refined considerations will not alter the fact that a major portion of the energy is transferable at high current to a parallel storage inductor.

2-MJ, Parallel Inductive Store

By applying this parallel storage concept, a high-voltage energy storage capability can be added to the existing NRL HPG facility. Further analysis of this specific system shows that currents of 200 kA should be obtainable from the HPG.

Magnetic Energy

In the circuit shown in Fig. 1 both the storage current and the excitation current pass through the axle brushes. The resulting brush voltage drop, neglected in the prior analysis, is common to both circuits. Due to this interaction, a large storage inductor current will reduce the voltage applied to the excitation circuit. In the NRL generator the rim brushes for each wheel are all connected in parallel to a collector ring. Now the simplest way to add an auxiliary storage inductor is to connect it to the two rings. If this is done, then the resistances of both axle and rim brushes are common to both circuits. The series resistance value for all four brush sets is estimated to be $40 \mu \Omega$. A numerical analysis has been done using that value of common resistance and the other circuit parameters given in Table 1. Currents and energies were

Table 1: Self-Excited HPG Parameters

I	= 5.94	kg-m ²
L ₁	= 1.4	mH
M	= 18.8	μH
R ₁	= 2.06	mΩ
v _o	= 260	Hz
i ₁₀	= 1	kA

calculated corresponding to various values of L_2 assuming $L_2/R_2 = 1$ s. Fig. 2 shows the resulting magnetic energy stored in the inductor L_2 as a function of the value selected for L_2 . The largest values shown are comparable to the exciter inductance (L_1) and the energy is about equally divided between the two circuits.

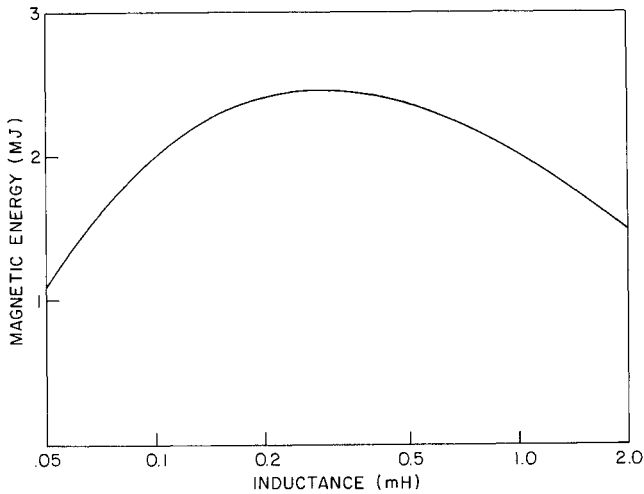

Fig. 2. Energy transferred to inductive storage from NRL HPG operating at 260 Hz .

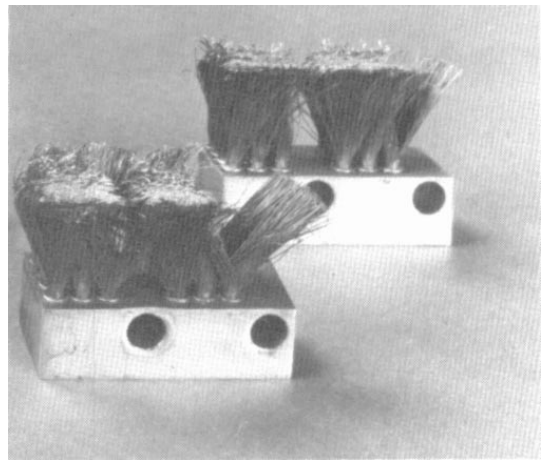

Fig. 3. Side view of 35 mm long, metal-fiber rim brushes after yielding at magnetic limit. All fibers are initially inclined like those on far right of each brush.

Decreasing values of L_2 result in greater energy in the storage coil. The storage energy is greater than 2 MJ over a range from 63 kA at 1.0 mH to 200 kA at 0.1 mH. The sharp reduction in energy transfer efficiency for smaller inductances is a result of the brush resistance. This sensitivity to brush resistance indicates a need for accurate measurement of brush voltage drops if this generator is to be used with storage inductors of 0.1 mH or less.

HPG Current Limit

The high-speed current collectors at the flywheel rims are all-metal fiber brushes similar to those first described by Reichner,⁴ and are being developed with his collaboration. Their current carrying capability was explored by operating the HPG with half of its normal brush complement to double the current per brush. For these tests each of the eighteen brushes on a wheel had about 4000 wires with diameters of either 0.005 in. or 0.006 in. Operation at a flywheel speed of 220 Hz (400 m/s) and 45 kA revealed a high-current limit where the smaller diameter wires, unable to withstand the magnetic forces, were bent backward as shown in Fig. 3. With a full complement of brushes this limiting current is increased to 64 kA corresponding to a flywheel speed of 270 Hz. (This is slightly greater than the speed used in the calculations for Fig. 2).

In considering the parallel inductor concept, it is significant that the current limit for rim brushes is due to magnetic forces, rather than due to contact surface melting. The magnetic force per unit length on an individual wire is the product of flux density (proportional to i_1) and the current (proportional to $i_1 + i_2$). In the case considered earlier where the two circuits have equal time-constants, it can be shown from the energy equations that $i_1(i_1 + i_2)$ is independent of the current division and dependent only on the energy level of operation. An increase in current per brush is compensated by a decrease in magnetic field so the rim brushes may be operated at higher currents with the parallel configuration without increasing their area. A modest area increase of a factor of two

would not be a major modification in any case.

The solid, copper-graphite axle brushes are operated at a current density of 7 MA/m^2 at 50 kA. At a current of 200 kA the current density would be pushed to 30 MA/m^2 . Although this is a factor of two greater than what is customarily used in the design of pulsed machines,^{5,6} it is much less than values reported for smaller area brushes.⁷ If experience proves that this current density is a problem, the wide axle brushes can be divided into narrower segments.

Coil Design

The numerical analysis which led to Fig. 2 indicates that the greatest practical current obtainable from the HPG is 200 kA. A separate energy storage inductor has been designed for operation by the HPG at this level. It will be constructed of 1.75 turn segments joined by large-area contacts as shown in Fig. 4. Seven of these series segments will

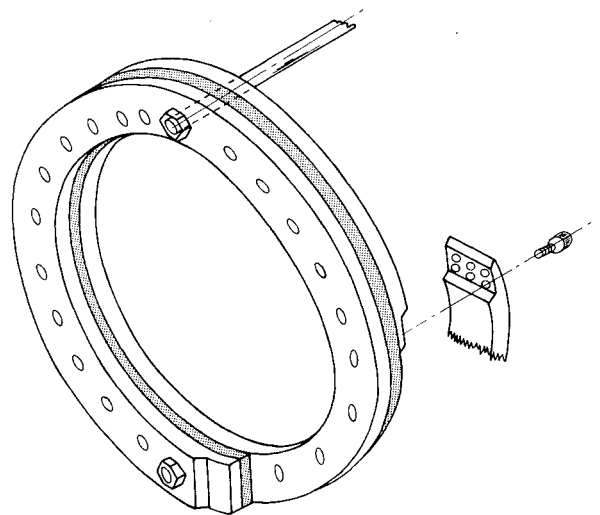

Fig. 4. Segment of 1-m diameter energy storage inductor constructed of 51 mm x 152 mm copper with 38 mm insulation gap between turns.

provide an inductance of 100 μH . The tie rods shown in the figure are needed to restrain the shear resulting from an expansive force 1.5×10^5 N/m on each turn at 200 kA.

To permit high-voltage operation the entire coil and its series switch will be placed underwater. The turns are separated by lucite since a clean lucite-water interface does not degrade the dielectric strength of water. The inter-turn spacing of 38 mm provides an overall dielectric length of 0.4 m. If operated at 1 MV, the average electric field will be 25 kV/cm, well below the breakdown field for water at 10 μs . The real limit to operating voltage is expected to be set by how well air bubbles can be removed from the interfaces.

Conclusion

Theoretical analysis of the parallel circuit concept and its application to the specific case of the NRL self-excited HPG show that a low-inductance storage coil can be energized with currents higher than those presently available. Separation of the energy storage and excitation functions permits the storage coil to be designed to operate at a much higher voltage. Taken together these advantages contribute greatly to upgrading the power output from the inductive storage system.

The absence of high-voltage interaction between inductive store and HPG excitation coil presents a possibility for future improvements in the HPG. If exciter coil dimensions are reduced to provide better coupling with the flywheels, then the resulting reduction of critical speed (R_1/M) will improve energy transfer efficiency. In addition, strategic gaps may be placed in the coil to permit easier maintenance of the inertial energy storage units.

The considerations just mentioned could also be applied to the design of even larger HPG powered inductive storage systems. Clearly a great advantage of the parallel circuit concept is that the HPG places virtually no limit on the design voltage level for the inductive storage output pulse,

References

1. A.E. Robson *et al*, "An Inductive Energy Storage System based on a Self-Excited Homopolar Generator," 6th Symp. on Engineering Problems of Fusion Research, IEEE Pub. No. 75CH1097-5-NPS (1976), p. 298.
2. W.H. Lupton *et al*, "Application of Homopolar Generators for High Voltage Plasma Experiments," 7th Symp. on Engineering Problems of Fusion Research, IEEE Pub. No. 77CH1267-4-NPS (1978), p. 430.
3. H. Knoepfel, "Pulsed High Magnetic Fields", North-Holland/American Elsevier, N.Y., p. 151.
4. P. Reichner, "Metallic Brushes for Extreme High Current Applications," Proc. 25th Holm Conference on Electric Contact Phenomena, Chicago, Sept, 10-12, 1979.
5. I.R. McNab, "Pulsed High Power Brush Research" IEEE Transactions CHMT-1 No. 1 (1978), p. 30.
6. R.A. Marshall, P. Reichner, and R.M. Slepian, "Current Collection Systems for Pulse Power Homopolar Machines," 7th Symp. on Engineering Problems of Fusion Research, IEEE Pub. No. 77CH1267-4-NPS (1978), p. 434.

7. R. A. Marshall, "Copper Graphite Brushes for Very High Current Density," Australian-US Seminar on Energy Storage, Compression and Switching, Canberra and Sydney, 1977, Books Australia, Norwalk, Conn., p. 196.