

A 220 KV PULSED CATHODE ELECTRON BEAM GUN SYSTEM

James P. O'Loughlin

Steven L. West

Air Force Weapons Laboratory

Kirtland AFB NM 87117

Summary

The electron beam gun system consists of a 5 x 25 cm aperture hot cathode gun and a thyatron switched line type high voltage pulse modulator. The gun is cathode pulsed with an operating range of 10 to 40 microseconds at a maximum voltage of 220 kV and maximum peak current of 20 amps. The equipment may be operated at a steady prf up to 150 pps for 15 seconds or in a burst mode of a few pulses each equivalent to the steady state rating. The pulse to pulse voltage stability is achieved at the expense of efficiency by resistive damping the power supply filter, using a resistive load in parallel with the gun and not counting the first low amplitude pulse of each burst.

Electron Gun

The electron gun cathode assembly consists of a stainless steel enclosure with an array of 13 tungsten wire emitters, .025 cm in diameter, 10 cm long and equally spaced at 1.9 cm. The emitters are heated with a current fed to the cathode assembly with a bifilar pulse transformer and high voltage bushing. The emission characteristics of the cathode are shown in Fig. 1. The cathode aperture is 5 x 25 cm and was originally fitted with 26 rods .15 cm in diameter and positioned with respect to the emitter wires as shown in Fig. 2. This configuration was intended to provide an electrostatic lens to collimate the beam. The design of this lens was based on a two dimensional electron trajectory code¹ which worked well in the crosssection perpendicular to the emitting wires and lens rods. However in the plane parallel to the emitter problems were encountered with this approach. The field penetration into the slots between the lens rods created a lens effect the two dimensional code did not predict satisfactorily. The result was a converging beam in the 5 cm dimension with a convergence angle of about 7°. This problem was corrected by replacing the lens rods with a coarse mesh screen with diamond shaped openings of approximately 1.25 x .75 cm. The screen established an average field penetration which was much more uniform over the aperture and reduced the convergence to less than about .5°. The problem could also be corrected by using an extraction grid between the emitter wires and the rods but this also would require the undesirable complication of providing an electrical pulsed drive signal to the grid. With the beam convergence corrected by the coarse screen the electron transmission efficiency measured from the cathode input current to the current thru the foil is about 65%.

Fig. 1
Emission
Characteristics

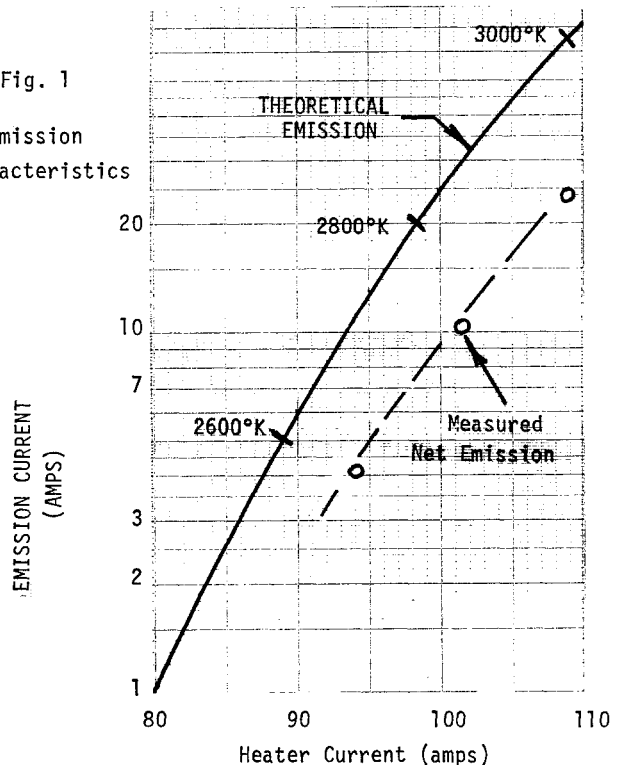
High Voltage Arcing

The E-Gun was intended to operate at 220 kV with a high degree of reliability. It eventually met this goal. Initial testing revealed two sources of high voltage arcs; down the bushing and the cathode assembly. The bushing is fabricated from nylon and is oil filled. In the original design the bushing was held in position with a threaded metal collar at the base on the vacuum side. The threads trapped gas and, being subjected to a very high electric field gradient created a plasma which initiated breakdowns from the threads across the surface of the bushing to the cathode. This problem was solved by modifying the bushing to eliminate the threaded metal collar on the vacuum side and replacing its function with a retaining ring on the oil side of the bushing. After this source of arcing at about 100 kV was corrected a breakdown problem then became evident at about 150 kV between the cathode shield structure and the vacuum chamber body.

Report Documentation Page

Form Approved
OMB No. 0704-0188

Public reporting burden for the collection of information is estimated to average 1 hour per response, including the time for reviewing instructions, searching existing data sources, gathering and maintaining the data needed, and completing and reviewing the collection of information. Send comments regarding this burden estimate or any other aspect of this collection of information, including suggestions for reducing this burden, to Washington Headquarters Services, Directorate for Information Operations and Reports, 1215 Jefferson Davis Highway, Suite 1204, Arlington VA 22202-4302. Respondents should be aware that notwithstanding any other provision of law, no person shall be subject to a penalty for failing to comply with a collection of information if it does not display a currently valid OMB control number.

1. REPORT DATE JUN 1981	2. REPORT TYPE N/A	3. DATES COVERED -			
4. TITLE AND SUBTITLE A 220 KV Pulsed Cathode Electron Beam Gun System		5a. CONTRACT NUMBER			
		5b. GRANT NUMBER			
		5c. PROGRAM ELEMENT NUMBER			
6. AUTHOR(S)		5d. PROJECT NUMBER			
		5e. TASK NUMBER			
		5f. WORK UNIT NUMBER			
7. PERFORMING ORGANIZATION NAME(S) AND ADDRESS(ES) Air Force Weapons Laboratory Kirtland AFB NM 87117		8. PERFORMING ORGANIZATION REPORT NUMBER			
9. SPONSORING/MONITORING AGENCY NAME(S) AND ADDRESS(ES)		10. SPONSOR/MONITOR'S ACRONYM(S)			
		11. SPONSOR/MONITOR'S REPORT NUMBER(S)			
12. DISTRIBUTION/AVAILABILITY STATEMENT Approved for public release, distribution unlimited					
13. SUPPLEMENTARY NOTES See also ADM002371. 2013 IEEE Pulsed Power Conference, Digest of Technical Papers 1976-2013, and Abstracts of the 2013 IEEE International Conference on Plasma Science. Held in San Francisco, CA on 16-21 June 2013. U.S. Government or Federal Purpose Rights License.					
14. ABSTRACT					
15. SUBJECT TERMS					
16. SECURITY CLASSIFICATION OF:			17. LIMITATION OF ABSTRACT SAR	18. NUMBER OF PAGES 4	19a. NAME OF RESPONSIBLE PERSON
a. REPORT unclassified	b. ABSTRACT unclassified	c. THIS PAGE unclassified			

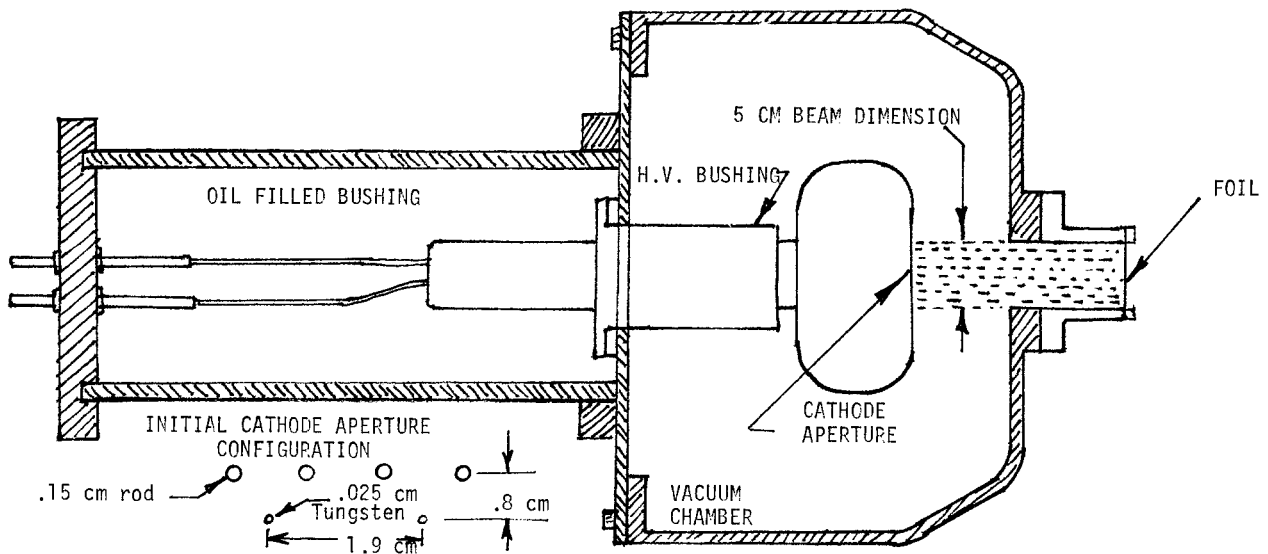

Fig. 2
E-Gun Configuration

High voltage conditioning by repeated arcing usually improved the breakdown level to the range of 160 to 170 kV. Careful polishing and removing sharp edges, screw heads, etc. did not lead to any measurable improvement. Reliable operation at 220 kV was finally obtained by a glow discharge conditioning process. In this process the gun is pumped down to its normal operating pressure of about 10^{-6} Torr and then back filled with He to about 500 Torr. The E-Gun cathode is then connected to the positive side of a high voltage d.c. power supply thru a 5000 ohm current limiting resistor. The He pressure is then slowly pumped down while the voltage is slowly increased, forming a glow discharge, with periodic breakdowns. The current is maintained in the 20 to 40 ma range until the voltage limit of the supply is reached at 60 kV at a pressure of about .01 Torr. The time for this to occur is about 15 minutes. The gun is then pumped down to about 10^{-6} Torr and operates reliably as high as -240 kV, which is the limit of the high voltage cathode pulser. At the design level of -220 kV, the arc rate is less than one pulse in 10,000. No degradation is observed if the gun pressure is released back to the atmosphere and then pumped back to 10^{-6} Torr. However, if the cathode assembly is removed from the chamber and contaminated by handling, it is necessary to repeat the He glow discharge process to regain reliable operation at voltages higher than 160 kV.

Power Conditioning

The cathode high voltage pulser is a thyratron switched line type modulator as shown in Fig. 3. The pulser consists of a high voltage d.c. power supply with an inductive input filter. The filter is damped by the 90 resistor R_1 , as explained later. The 14 section PFN is resonant charged via the charging inductor L_2 and holding diode CR_1 . The width of the pulse is adjustable from 40 microseconds downward by using correspondingly fewer of the 14 PFN sections. The switch tube, V_1 , is a KU-275C hydrogen thyratron which discharges the PFN into the primary of the 1:11 step up pulse transformer T_1 .

The primary of the pulser transformer is also provided with an inverse voltage clipper, hard vacuum diode type 2-2000A. The clipper is required to provide additional load for the transformer backswing. The pulse transformer has a flux reset bias winding which is driven by a d.c. power supply thru a pulse isolation inductor L_3 . The use of flux reset or bias

allows the transformer core to operate with a flux swing approaching twice that of an unbiased core. Thus much less core material is required and the transformer is smaller and less expensive than a unit without core bias. The secondary of the transformer is bifilar and is used to provide heater power to the E-Gun. 480 volt power is fed up the bifilar winding to a filament step down transformer at the hot end. The filament transformer is in the same oil filled case with the pulse transformer. The filament and pulse power are both fed to the E-Gun thru a bifilar high voltage bushing. A copper sulfate resistor R_4

loads the secondary of the pulse transformer in parallel with the E-Gun. In the event of a load arc the reflected power is sensed in the inverse diode circuit CR_2 and R_3 via the Pearson transformer CT_1 and a trigger blanking circuit is activated. The majority of the reflected power from such a load arc fault is dissipated in the "end of line" clipper CR_3 , R_4 on the PFN. Using a line modulator to pulse an E-Gun presents three salient problems; (1) the first pulse is always low in amplitude unless a command charging circuit is used, (2) operating the gun over a range of currents creates impedance matching problems, and (3) power supply filter ringing causes varying amplitude pulses at the beginning of each burst. The problem of the low amplitude first pulse was tolerated in this particular application by essentially ignoring it. Specifically, the E-Gun system is used to provide ionization for an electrical discharge laser (EDL). The system is programmed to blank the electrical power loading to the EDL on the first pulse allowing only the E-Gun to fire and thus ring up to rated amplitude on the second and following pulses. The problem of the impedance match changing with changes in E-Gun operating current was overcome by swamping out the E-Gun impedance variation with a high voltage 100 liter copper sulfate resistor R_4 in parallel with the E-Gun.

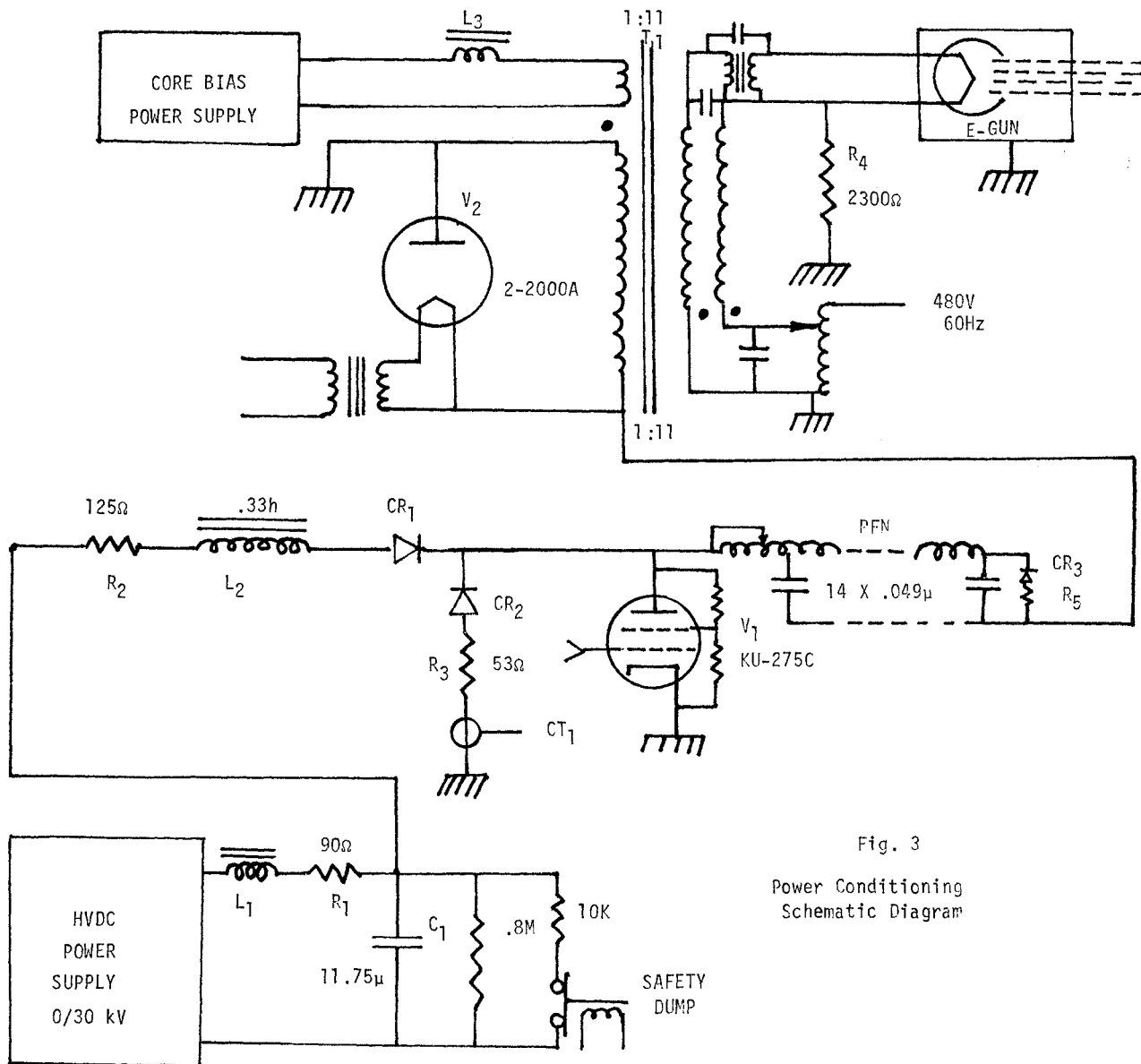

Fig. 3
Power Conditioning
Schematic Diagram

A 2300 ohm resistance is used which provides a net impedance variation to the modulator of 2300 ohms to 1900 ohms as the E-Gun current varies from zero to 20 amps peak. This is obviously an electrically inefficient solution but for laboratory use is more practical and economical than changing PFN impedances to match each 20% change in E-Gun impedance. Of course a hard tube modulator could have been used but this is an even more expensive alternative than multiple PFNs. The output voltage waveform is shown in Fig. 4. The waveform shown is quite noisy due to the high attenuation of the voltage viewing divider and thus the very low level signal fed into the waveform digitizer. A most troublesome problem was the amplitude variation caused by the ringing of the power supply filter at the beginning of each burst. The amplitude variation resulted in a modulation of the EDL discharge impedance, and thus the laser cavity voltage. This could not be tolerated for two reasons. First the cavity is operated near the breakdown level and numerous cavity arcs resulted

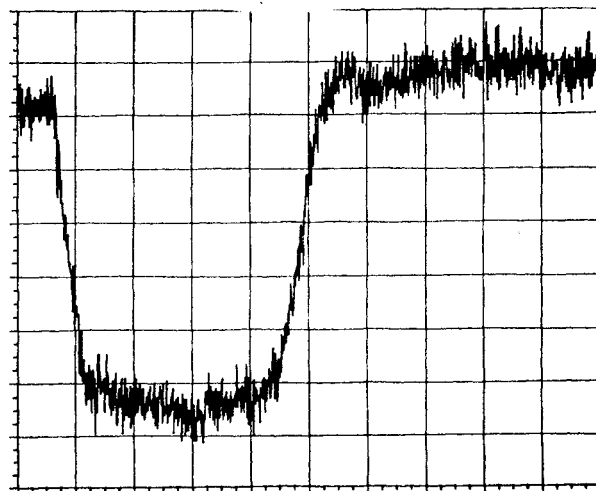

Fig. 4
Output Voltage Waveform
Approx. 40 kV/cm, 10μsec/cm

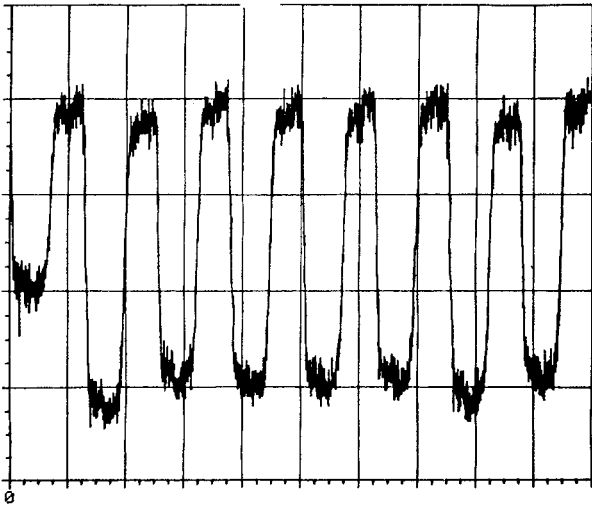

Fig. 5

Output voltage burst without R_1
 Approximately 70 kV/cm, negative pulses.
 Pulse width approximately 30 microseconds.
 PRF = 150.

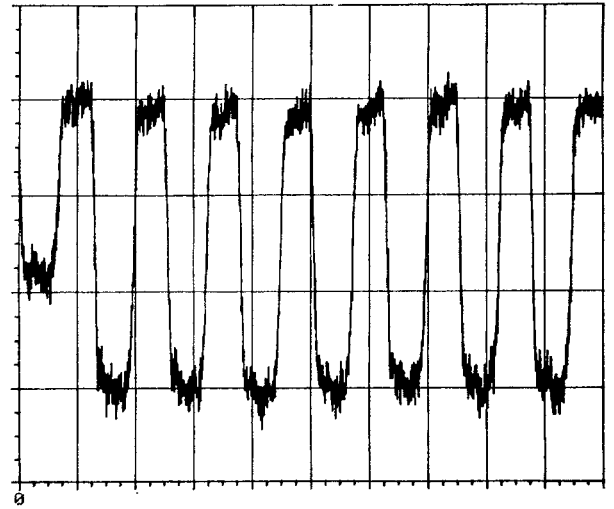

Fig. 6

Output voltage burst with $R_1 = 90 \Omega$
 Approximately 70 kV/cm, negative pulses.
 Pulse width approximately 30 microseconds.
 PRF = 150

Second, the corresponding change in energy loading is even greater than the voltage modulation and would result in unacceptable variations in the laser pumping. The ringing of the power supply filter was reduced to an acceptable level by the damping action of R_1 . It was necessary to increase R_1 to 90Ω in order to decrease the voltage ringing to an acceptable level. A wave form digitizer (Tektronix) was used to record the first few pulses of a burst with and without R_1 in the circuit. The data was taken at 150 PPS and is shown in Figs. 5 and 6. The time base is compressed between pulses, the pulse width is 30 microseconds and the time between pulses is 6.67 milliseconds. The addition of damping to the filter circuit was chosen as the solution to the problem in this case because the power supply had the filter inductor built in as an integral component. A better solution for similar situations in the future is to use a capacitive input filter for the power supply. The capacitive filter eliminates the ringing problem more efficiently than a damped L-C filter and usually results in a smaller and more economic overall system.²

References

- (1) T. E. Springer and W. J. Sarjeant, "Electron Beam Gun Simulation", Final Report AFWL Project 80-148, LANL E-D0-740-80, Jan. 1981.
- (2) J. P. O'Loughlin and S. L. West, "Effects of Transformer Leakage Inductance on Capacitive Input Filters", 3rd IEEE International Pulsed Power Conference, June 1981.