

Juan J. Ramirez
Sandia National Laboratories
Albuquerque, New Mexico 87185

Summary

Electron beam generator engineering trade-offs involved in decreasing the output duration of a large KrF laser by a factor of two so as to double the peak power delivered to an ICF target are discussed.

Introduction

A number of studies have investigated the feasibility of extending the rare gas halide laser technology to megajoule class systems for inertial confinement fusion (ICF) applications.¹ In all of these systems the laser medium is excited by a high power relativistic electron beam. Since this is not an energy storing laser medium, the output energy of an amplifier must be extracted over the entire duration of the e-beam pump pulse. At present there is insufficient data to establish the optimum e-beam pulsewidth for a large amplifier module. This number is usually taken to be a few hundred nanoseconds based on various laser kinetic issues and pulsed power considerations. On the other hand ICF target designs require irradiation times of only a few nanoseconds. Angular multiplexing consists of passing a number of short probe beams in series through the amplifier cavity extracting all the available laser energy. These amplified beams are then appropriately delayed and synchronously recombined at the target. For a given target irradiation time the ratio of the e-beam pulsewidth and the number of probe beams is fixed. The optimum value for either of these parameters must however be determined from other considerations.

The optimum target irradiation time is determined by pellet design considerations. This time interval depends on the total energy delivered and may be in the order of 10 nsec when several megajoules are delivered to the target. Any near term application of KrF to ICF would be somewhere near the 100 kJ level and a premium would be placed on obtaining the shortest reasonably attainable pellet irradiation time. Given a nominal design, a relevant question then becomes one of how to deliver the same total energy on target in half the time. This could be accomplished by using probe beams with half the pulsewidth and by either doubling the number of probe beams while keeping the e-beam pulsewidth constant or by halving the e-beam pulsewidth while keeping the number of probe beams constant. This paper addresses that tradeoff. We look specifically at a 25 kJ amplifier module based on either a 500 nsec or a 250 nsec e-beam pump.

This work was motivated by a request from Los Alamos National Laboratories to participate in a design study. They are investigating the feasibility of building a large KrF amplifier pumped by a 500 nsec e-beam. The design and scaling criteria provided for this study² are listed below:

- (1) Transverse ASE--(pump rate) x (aperture width)
= (constant)
(1 meter at 500 nsec for 20-25 kJ amplifier)

- (2) Loadings on the optical components must be limited to
 - 3 J/cm² on HR surfaces
 - 6 J/cm² on AR surfaces
- (3) The intrinsic laser efficiency, $\eta = E(\text{laser})/E(\text{deposited})$
 - is 12 percent at 100 nsec
 - 10 percent at 500 nsec
 - and 8 percent at 1000 nsec
- (4) The voltage of the e-beam driver scales linearly with the width of the amplifier cavity.
(Ref. 675 kilovolts at 1 meter)
- (5) The voltage of the e-beam driver scales linearly with the pressure in the amplifier cavity.
(Ref. 675 kilovolts at 1.7 atmospheres)
- (6) The pressure in the amplifier cavity scales directly with the e-beam pulse width.
(Ref. 3 atm at 50 nsec; 1.7 atm at 500 nsec)
- (7) Angular multiplexing of the amplifier cavity limits its aspect ratio to $L/W < 4$.
- (8) The system architecture must be scalable to megajoule class lasers.
- (9) The output e-beam pulse parameters are constrained by:
 - (a) voltage--constant within +7 percent
 - (b) power--constant within +15 percent
 - (c) 10/90 rise and fall times < 20 percent of pulse width
- (10) The e-beam diode operates under space charge limited conditions. These conditions are reached instantaneously and the effective gap closure velocity is 2 cm/ μ sec.

The System Designs

The above criteria were used to generate four different 25 kJ amplifier designs. The 500 nsec design is similar to the one being studied at Los Alamos and was used to provide a consistent comparison basis for the 250 nsec designs. In order to facilitate adequate comparisons between the various pulsed power systems, the same assumptions about power flow efficiencies were made in all four designs.

A given amplifier design began by determining the cavity dimensions and the number of e-beam modules driving the cavity. The design and scaling criteria were then used to determine the requirements on the pulsed power modules. The intrinsic laser efficiency determines the total energy that the e-beams must deliver to the gas medium. Having determined the diode voltage from the scaling data, the current and current density in the gas provided by each module was calculated. It was then assumed that 60 percent of the output current from the PFL module actually gets delivered to the gas. This determines the total current that must be delivered by each PFL module and thus its impedance. The necessary Marx generator energy was determined by further assuming that 80 percent of the energy stored in the Marx is delivered by the PFL in the time of interest, i.e., the interval defined by the FWHM of the output power pulse. The voltage rise time at the diode is approximately given by Eq. 1.

*This work was supported by the U.S. DOE under Contract DE-AC04-76-DP00789.

Report Documentation Page

Form Approved
OMB No. 0704-0188

Public reporting burden for the collection of information is estimated to average 1 hour per response, including the time for reviewing instructions, searching existing data sources, gathering and maintaining the data needed, and completing and reviewing the collection of information. Send comments regarding this burden estimate or any other aspect of this collection of information, including suggestions for reducing this burden, to Washington Headquarters Services, Directorate for Information Operations and Reports, 1215 Jefferson Davis Highway, Suite 1204, Arlington VA 22202-4302. Respondents should be aware that notwithstanding any other provision of law, no person shall be subject to a penalty for failing to comply with a collection of information if it does not display a currently valid OMB control number.

1. REPORT DATE JUN 1983	2. REPORT TYPE N/A	3. DATES COVERED -			
4. TITLE AND SUBTITLE E-Beam Pulsewidth Scaling For A Large Krf Laser		5a. CONTRACT NUMBER			
		5b. GRANT NUMBER			
		5c. PROGRAM ELEMENT NUMBER			
6. AUTHOR(S)		5d. PROJECT NUMBER			
		5e. TASK NUMBER			
		5f. WORK UNIT NUMBER			
7. PERFORMING ORGANIZATION NAME(S) AND ADDRESS(ES) Sandia National Laboratories Albuquerque, New Mexico 87185		8. PERFORMING ORGANIZATION REPORT NUMBER			
9. SPONSORING/MONITORING AGENCY NAME(S) AND ADDRESS(ES)		10. SPONSOR/MONITOR'S ACRONYM(S)			
		11. SPONSOR/MONITOR'S REPORT NUMBER(S)			
12. DISTRIBUTION/AVAILABILITY STATEMENT Approved for public release, distribution unlimited					
13. SUPPLEMENTARY NOTES See also ADM002371. 2013 IEEE Pulsed Power Conference, Digest of Technical Papers 1976-2013, and Abstracts of the 2013 IEEE International Conference on Plasma Science. Held in San Francisco, CA on 16-21 June 2013. U.S. Government or Federal Purpose Rights License.					
14. ABSTRACT					
15. SUBJECT TERMS					
16. SECURITY CLASSIFICATION OF:			17. LIMITATION OF ABSTRACT SAR	18. NUMBER OF PAGES 4	19a. NAME OF RESPONSIBLE PERSON
a. REPORT unclassified	b. ABSTRACT unclassified	c. THIS PAGE unclassified			

$$\tau_R(10/90) = 2.2[L(\text{diode}) + L(\text{switch})] / [Z_o + Z(\text{load})] \quad (1)$$

where L(diode) and L(switch) are the diode and PFL output switch inductances. Z_o and Z(load) are the PFL impedance and the load impedance respectively. Assuming 100 nH/MV inductance for the output spark gaps and a specific number of gaps per PFL, the maximum allowable diode inductance consistent with the output rise time requirements was calculated.

The 500 nsec Design

This 25 kJ cavity is 1 meter by 1 meter by 2 meters long. It is pumped by four e-beam modules configured for dual sided irradiation of the cavity. Table I summarizes the major system characteristics of this design. All of the pulsed power parameters appear to be attainable. It should be possible to operate two parallel output gaps per PFL and the diode inductance required to get a 10/90 output rise time of 100 nsec should not be difficult to obtain. The performance of the large area e-beam diode is a major uncertainty.

TABLE I

Major System Characteristics for the 500 nsec Design

Cavity dimensions	1 m x 1 m x 2 m
Pump rate	2.5×10^5 W/cc
Number beams/diodes:	4
$J_{\text{beam}}(\text{gas})$	18.5 A/cm^2
$V_{\text{PFL}}(\text{out})$	675 kV
Z(PFL)	2.2Ω
L(switch)	68 nH
L(diode)	$< 135 \text{ nH}$
E(Marx total)	624 kJ

The 250 nsec Design--Option A

In this design we assume that the cavity pump time is cut in half and the pump rate is doubled relative to the 500 nsec design. The 25 kJ amplifier in this option consists of four subcavities. Each subcavity is 0.5 meters by 0.5 meters by 1.78 meters long and delivers 6.25 kJ laser energy. The four subcavities stack on top of each other and are fed by two opposing e-beams. Table II summarizes the major system characteristics of this design. The major challenge in this design is the low voltage, high current source required. Four parallel gaps would have to be used for each PFL and the diode inductance would have to be $< 33 \text{ nH}$ in order to get the desired 50 nsec voltage rise time. This design would be significantly more difficult to implement than the following options.

The 250 nsec Design--Option B

This 25 kJ amplifier cavity is 1 meter by 1 meter by 3 meters long. It is pumped by six e-beam modules arranged for dual sided irradiation. Table III summarizes the major system characteristics for this design. The major feature of this design is that the source output voltage and PFL impedance have been significantly increased over those of Option A. In fact these parameters are larger than those for the 500 nsec design. The diode inductance must be

$< 74 \text{ nH}$ in order to meet the 50 nsec rise time requirements. This seems to be an attainable value.

TABLE II

Major System Characteristics for 250 nsec Design Option A

Subcavity dimensions	0.5 m x 0.5 m x 1.78 m
Pump rate	5.0×10^5 W/cc
Number beams/diodes	8
$J_{\text{beam}}(\text{gas})$	26 A/cm^2
$V_{\text{PFL}}(\text{out})$	480 kV
Z(PFL)	1.25Ω
L(Switch)	24 nH
L(diode)	$< 33 \text{ nH}$
E(Marx total)	552 kJ

TABLE III

Major System Characteristics for 250 nsec Design Option B

Cavity dimensions	1 m x 1 m x 3 m
Pump rate	2.96×10^5 W/cc
Number beams/diodes	6
$J_{\text{beam}}(\text{gas})$	15.4 A/cm^2
$V_{\text{PFL}}(\text{out})$	960 kV
Z(PFL)	3.74Ω
L(Switch)	96 nH
L(diode)	$< 74 \text{ nH}$
E(Marx total)	555 kJ

The 250 nsec Design--Option C

The purpose of this option is to allow for a higher diode inductance than is allowed in Option B. This 25 kJ cavity is 1 meter by 1 meter by 4 meters long. It is pumped by eight e-beam modules arranged for dual sided irradiation. Table IV summarizes the major system characteristics. It can be seen that this design allows a diode inductance $< 130 \text{ nH}$ while still maintaining the rise time requirements. This value of inductance should be readily achievable

TABLE IV

Major System Characteristics for 250 nsec Design Option C

Cavity dimensions	1 m x 1 m x 4 m
Pump rate	2.22×10^5 W/cc
Number beams/diodes	8
$J_{\text{beam}}(\text{gas})$	11.6 A/cm^2
$V_{\text{PFL}}(\text{out})$	960 kV
Z(PFL)	4.97Ω
L(Switch)	96 nH
L(diode)	$< 130 \text{ nH}$
E(Marx total)	556 kJ

Computer Simulations

The calculations presented in the previous sections show that design options B and C compare very favorably to the 500 nsec design from the systems point of view. The performance of these three pulsed power designs were simulated using the SCEPTRE network analysis code³ to determine if they could meet the voltage and power uniformity specifications.

The equivalent circuit model for the 500 nsec design is shown in Fig. 1. The elements enclosed by the dashed line represent the Marx generator that charges the PFL. This generator is assumed to be similar in design to the PBFA Marx generator.⁴ The sum of the Marx and feed inductances was adjusted to give the desired PFL charge time. The PFL has a two way transit time of 600 nsec and characteristic impedance of 2.2Ω . The resistivity of the water dielectric was assumed to be 3×10^6 ohm-cm for all designs considered. The diode and output switch inductances were obtained from Table I. The time varying load impedance models an e-beam diode that reaches space charge limited conditions instantaneously, operates with a current density of 18.5 A/cm^2 and has an effective A-K gap closure velocity of $2 \text{ cm}/\mu\text{sec}$.

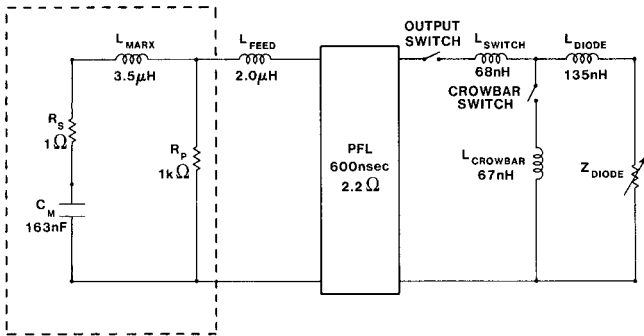

Fig. 1. Equivalent circuit model for the 500 nsec design.

Figure 2 shows the diode voltage when the Marx generator is charged to 1.41 MV and the output switch is closed $1.56 \mu\text{sec}$ into the charging waveform of the PFL. The dashed lines represent the ± 7 percent points about the 675 kilovolt level. The arrows indicate a 500 nsec window wherein the voltage meets the desired specification. Figure 3 shows the power delivered by the diode to the anode. In this figure the dashed lines represent the ± 15 percent points about an average power given by 675 kilovolts and 2.2 ohms . The arrows are the same as in Fig. 2. The diode power falls below the -15 percent line during the first 50 nsec of this 500 nsec window. This results because the diode impedance is high during the early part of the voltage pulse. There does exist a 500 nsec time window wherein the diode power meets the ± 15 percent criteria about an average power of 0.185 terawatts.

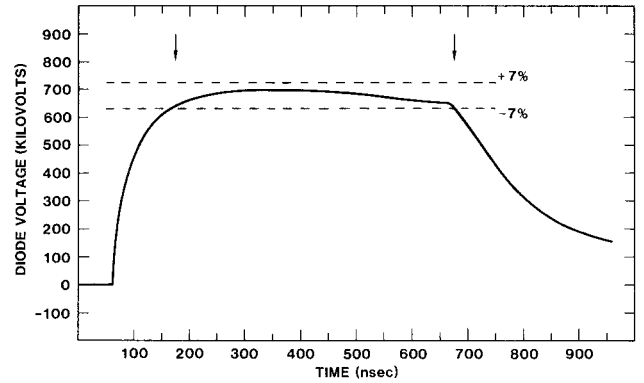

Fig. 2. Diode voltage waveform resulting from a Marx charge of 1.41 MV and an output switch closure of $1.56 \mu\text{sec}$. The dashed lines are the ± 7 percent points about an average of 675 kV.

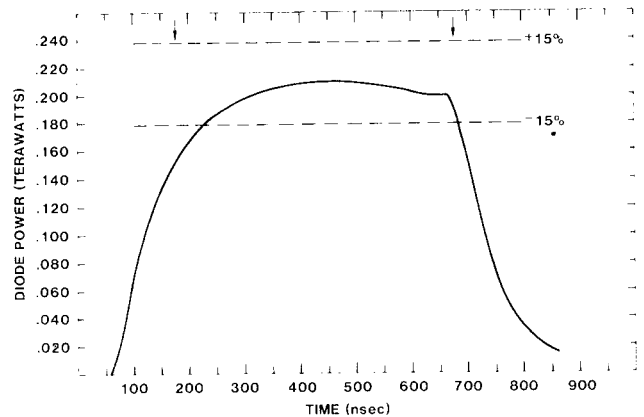

Fig. 3. Power delivered by e-beam to anode. The dashed lines are the ± 15 percent points about an average of 0.185 terawatts.

The equivalent circuit model for the 250 nsec design Option B is shown in Fig. 4. The elements enclosed by the dashed line represent a 24 stage Marx generator. Each stage consists of one $1.0 \mu\text{F}$, 100 kV capacitor. The sum of the Marx and feed inductances was adjusted so as to get the desired charge time for the PFL. The values for the PFL parameters and for the diode and output switch inductances were obtained from Table III. The time varying load impedance models an e-beam diode that instantaneously reaches space charge limited conditions, operates with a uniform current density of 15 A/cm^2 , and has an effective gap closure velocity of $2 \text{ cm}/\mu\text{sec}$.

Figure 5 shows the diode voltage when the Marx generator is charged to 2.1 MV and the output switch is closed $1.068 \mu\text{sec}$ into the charging waveform of the PFL. The dashed lines represent the ± 7 percent points about the 960 kV level. The arrows indicate a 250 nsec window wherein the voltage meets the stated uniformity specifications. Figure 6 shows the power delivered by the e-beam to the anode. The dashed lines in this figure represent the ± 15 percent points about an average power given by 960 kV and 3.75Ω . The arrows locate the same time window as in Fig. 5. The power waveform meets the uniformity specification during this time interval.

The computer simulation of the 250 nsec design-Option C show that this design also meets the voltage and power uniformity specifications.

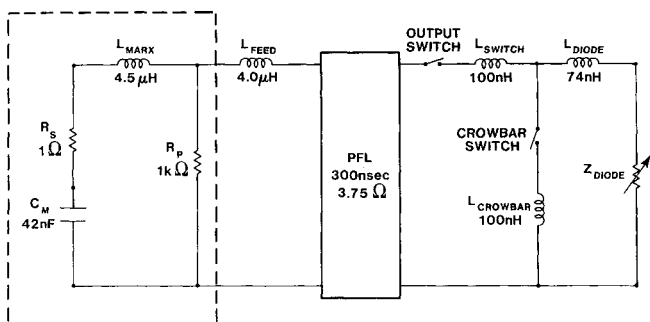

Fig. 4. Equivalent circuit model for the 250 nsec design-Option B.

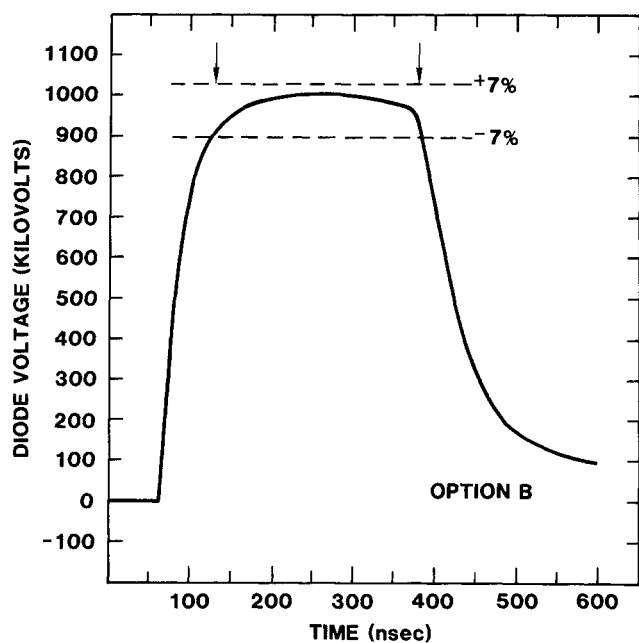

Fig. 5. Diode voltage waveform resulting from a Marx charge of 2.1 MV and an output switch closure of 1.07 μ sec.

Conclusions

We have looked at pulsed power systems needed to drive 25 kJ KrF amplifier designs based on 500 nsec and 250 nsec e-beam pumps. Two of the 250 nsec designs require pulsed power systems which do not differ significantly, other than pulsewidth, from that of the nominal 500 nsec design. The key technical risk for all three designs is in the performance of the large area low current density diodes that are required. Although there are some differences in the operating parameters one should not expect major differences in the operation of these diodes. There is insufficient data available in this area to make an accurate quantitative assessment of the relative technical risks associated with these designs. A rough hardware cost estimate, including the required applied B-field, indicates that the cost of Option B would be 10 percent higher than the cost of the 500 nsec design while Option C would cost 24 percent

more. We may conclude from this exercise that the power on target could be doubled by halving the e-beam pulsewidth to 250 nsec at a cost penalty of less than 25 percent and very little added technical risk.

The other option for doubling the power on target is to keep the e-beam pulse width at 500 nsec and double the number of probe beams. If we say that the cost of doubling the number of probe beams is to double the cost of the optics hardware, then it is clear that, for the systems considered here, halving the e-beam pulse width would be the least expensive way of doubling the power on target as long as the cost for the optics hardware in the system is greater than 62 percent of the cost for the pulsed power hardware in the system.

In this report we have looked at two specific e-beam pulsewidths and compared them based on scaling criteria that are known to be soft. It would be desirable to be able to determine the optimum pulsewidth for the e-beam pump for a given size KrF amplifier. We do not believe that enough is known at present about the performance of the laser or the e-beams to allow such a determination.

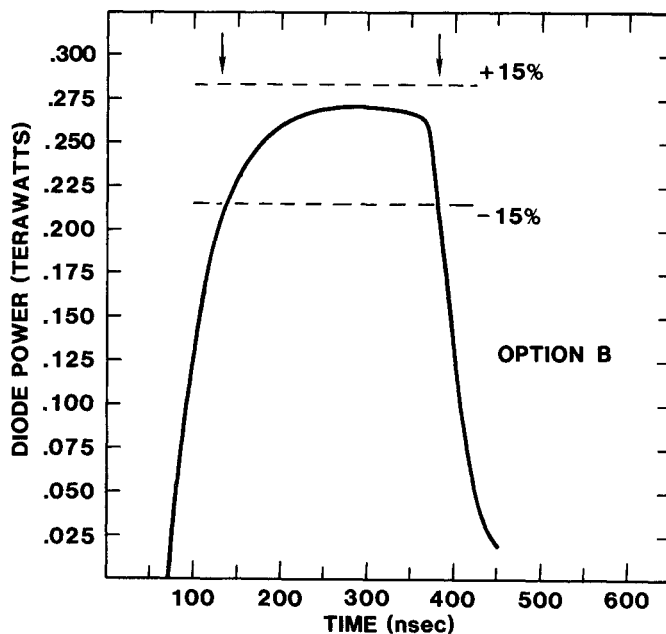

Fig. 6. Power delivered by the e-beam to anode.

References

1. J. J. Ewing, R. A. Haas, J. C. Swingle, E. V. George and W. F. Krupke, *IEEE J. Quant. Elect.*, QE-15, 368 (1979).
2. Gary Allen, private communication.
3. James C. Bowers and Stephen R. Sedore, *SCEPTRE: A Computer Program for Circuit and System Analysis*, (Prentice-Hall, Inc, Englewood Cliffs, NJ, 1971).
4. T. H. Martin, G. W. Barr, J. P. VanDevender, R. A. White, and D. L. Johnson, *Proceedings of the 1980 IEEE Fourteenth Pulse Power Modulator Symposium* (Orlando, FL, June 3-5, 1980) p. 300.