

## Spark Gap Insulator Wall Survivability

William Wright, Jr.  
US Army Electronics Technology & Devices Laboratory, (ERADCOM)  
Fort Monmouth, NJ 07703

### SUMMARY

Various insulator materials, including acrylic plastic, fused silica, Transite (an inexpensive asbestos-cement), and Pyrex have been investigated to determine their abilities to survive the hostile environment of a gas-filled spark gap operating at 8 kJ and 0.4C per pulse and 40 kA peak current at repetition frequencies up to a few tens of hertz. Damage mechanisms observed have included mechanical fracture, softening and deformation, ablation, crazing, current tracking, electrode-material deposition, and UV solarization. The acrylic walls failed from softening and ablation, the Transite from current tracking between laminations, and the fused silica from mechanical fracture. The Pyrex walls have darkened from deposits but are still running. Good results have been obtained with Pyrex, a composite wall of acrylic and Transite, and acrylic alone with the electrodes liquid-cooled.

### INTRODUCTION

A study was undertaken to determine failure modes of various dielectric materials which had been, or could be, used for insulator walls in repetitively triggered spark gaps. While realizing that the optimum material is probably a dense ceramic with good thermal shock resistance, it is inherently expensive and is a long lead-time item, and the study looked at inexpensive and/or easily fabricated materials: cast acrylic, Transite, Pyrex and combinations of these. Fused silica, the one exception to the cheap/easy criterion, was tried because its ability to pass UV allowed the pre-ionizing source to be placed outside the envelope.

A rather simple three-electrode gap with a mildly vortex gas flow was used as a test bed for the walls. Features which would have improved the wall life, such as baffles to prevent line-of-sight from the arc column to the wall, low erosion electrode material, and arc-stops to prevent a long duration fault-mode discharge from traveling to the walls were omitted to produce accelerated wall failures. The center-electrode was operated both with and without water cooling. Operation of the gap was with the lower electrode grounded, the midplane resistively biased at 40 percent above ground and triggered negatively with a 100 kV, 5 ns risetime pulse. With the 60 percent gap to the anode and the trigger polarity negative, the longer gap fires first, providing a large overvoltage for the shorter gap and a good operating range. The energy store was a 10  $\mu$ s, 0.5 ohm, 5 section PFN command-charged up to 40 kV in 2.5 ms; the load was a 0.5 ohm low-

inductance resistor. The gap was normally triggered 5 ms after completion of PFN charging. The current risetime was circuit-limited to 1 to 2  $\mu$ s, depending on physical placement of the switch, making the commutation losses in the switch a small fraction of the conduction loss. The PFN stored 8 kJ and 0.4 C at 40 kV, and most of the operation was in long runs (many minutes) at 30 Hz for 15 s alternating with 3 Hz for 45 s. The short and long term average powers were 0.24 Mw and 78 kW respectively. The flow conditions were normally 300 SCFH of compressor-supplied room air. A coalescing filter removed the oil aerosols, but no attempt was made to remove oil or water vapors. The pressure in the gap was 20 psig, giving a comfortable range between no-fire (failure to trigger) and pre-fire (closure of the gap prior to triggering). No-fires, and pre-fires after completion of charging, caused no difficulty; pre-fire during PFN charging, while the charging thyatron was conducting, allowed the capacitor bank to dump through the gap, as well as the power supply short-circuit current until the overload sensors and main breaker disconnected from the 4160 VAC line.

### Charging and Discharging Circuits

The PFN was command-charged to give the spark gap a zero-voltage condition to aid gap recovery. The 50  $\mu$ F capacitor bank, backed by a stiff power supply (50 amp DC rating), charged the 10  $\mu$ F PFN through a 0.15 Hy inductor and an EEV CX 1536 two-gap gradient grid thyatron operating off-ground, heated and triggered through isolation transformers. The CX 1536 was prevented from retriggering in response to the transients generated by the spark gap discharging the PFN by low capacity 10  $\mu$ H chokes in the anode and cathode leads, a diode-capacitor inverse clipper from cathode to ground and, most importantly, a capacitor from the gradient grid to cathode which bypassed the transients around the cathode-control grid space. Capacitors and varistors between control grid and cathode completed the protection against retriggering. The charging current was a half sine wave, 2.5 ms between zero crossings, with a slight inverse current as the thyatron recovers. The transient from the sudden stoppage of this inverse current through the inductor caused several faults before the diode-capacitor clipper was installed. Figures 1 and 2 show the schematic and physical layout of the charging circuit, respectively.

Figure 3 shows the PFN, spark gap, and trigger unit; a 0.5 ohm liquid load resistor is connected to the gap and PFN by an array of 50 ohm cables. Because physical damage was the major interest, only the charging waveform, PFN voltage, and

# Report Documentation Page

Form Approved  
OMB No. 0704-0188

Public reporting burden for the collection of information is estimated to average 1 hour per response, including the time for reviewing instructions, searching existing data sources, gathering and maintaining the data needed, and completing and reviewing the collection of information. Send comments regarding this burden estimate or any other aspect of this collection of information, including suggestions for reducing this burden, to Washington Headquarters Services, Directorate for Information Operations and Reports, 1215 Jefferson Davis Highway, Suite 1204, Arlington VA 22202-4302. Respondents should be aware that notwithstanding any other provision of law, no person shall be subject to a penalty for failing to comply with a collection of information if it does not display a currently valid OMB control number.

1. REPORT DATE <b>JUN 1983</b>		2. REPORT TYPE <b>N/A</b>		3. DATES COVERED <b>-</b>	
4. TITLE AND SUBTITLE <b>Spark Gap Insulator Wall Survivability</b>				5a. CONTRACT NUMBER	
				5b. GRANT NUMBER	
				5c. PROGRAM ELEMENT NUMBER	
6. AUTHOR(S)				5d. PROJECT NUMBER	
				5e. TASK NUMBER	
				5f. WORK UNIT NUMBER	
7. PERFORMING ORGANIZATION NAME(S) AND ADDRESS(ES) <b>US Army Electronics Technology &amp; Devices Laboratory, (ERADDOM) Fort Monmouth, NJ 07703</b>				8. PERFORMING ORGANIZATION REPORT NUMBER	
9. SPONSORING/MONITORING AGENCY NAME(S) AND ADDRESS(ES)				10. SPONSOR/MONITOR'S ACRONYM(S)	
				11. SPONSOR/MONITOR'S REPORT NUMBER(S)	
12. DISTRIBUTION/AVAILABILITY STATEMENT <b>Approved for public release, distribution unlimited</b>					
13. SUPPLEMENTARY NOTES <b>See also ADM002371. 2013 IEEE Pulsed Power Conference, Digest of Technical Papers 1976-2013, and Abstracts of the 2013 IEEE International Conference on Plasma Science. Held in San Francisco, CA on 16-21 June 2013. U.S. Government or Federal Purpose Rights License.</b>					
14. ABSTRACT					
15. SUBJECT TERMS					
16. SECURITY CLASSIFICATION OF:			17. LIMITATION OF ABSTRACT <b>SAR</b>	18. NUMBER OF PAGES <b>4</b>	19a. NAME OF RESPONSIBLE PERSON
a. REPORT <b>unclassified</b>	b. ABSTRACT <b>unclassified</b>	c. THIS PAGE <b>unclassified</b>			

discharge current pulse were monitored electrically. The load was matched to the PEN to avoid coulomb transfer in ringing pulses.

### Spark Gap and Gas Flow

The spark gap used for wall testing was a three-electrode type made by Impulse Electronics and patterned after one developed at Sandia by Rohwein. The overall dimensions, including corona protection but not gas flow manifolding, were 8 in. diameter and 6.5 in. length. The copper end electrodes were 2 in. diameter, 2.5 in. long, with a 0.75 in. axial hole for hot gas exhaust. The center electrode was a copper plate 0.5 in. thick, 5.5 in. diameter with 0.75 in. hole in the center; the hole edges were rounded. The total gap length was 0.500 in.; 0.313 in. anode to center, and 0.188 in. cathode to center. The ratio of spacings was approximately 60/40, and the center electrode was resistively biased 40 percent above ground with an 8/12 megohm divider string. The wall diameter was approximately 4 in. for all insulator types. The gas flow was fed through four manifolded holes in each end plate between the end electrode and the wall with a small amount of vorticity, exiting through the holes in the end electrodes. It was necessary to use a short coil of air-cooled metal tubing on the exhaust ports to prevent melting the plastic tubing, which was necessary for potential isolation.

The center electrode ran appreciably hotter than the end electrodes, apparently because of less contact with the flowing gas, and because it acts both as an anode for the lower gap and a cathode for the upper. Because of the symmetry, there is no gas flow through the hole in the center. When liquid cooling coils were added to the center electrode, reducing its edge temperature from 133°C to 30°C, the prefire rate improved by over an order of magnitude, indicating that the stagnant gas being heated by contact with this hot electrode is losing its dielectric holdoff strength and the effective gap spacing is decreasing.

At a nominal flow of 300 SCFM and field-stressed volume of 1.6 in.<sup>3</sup>, the clearing factor was 77 at a pulse repetition rate of 30 Hz. The switch total volume of 69.1 in.<sup>3</sup> was flushed 1.8 times per pulse for the same conditions. Switch recovery and prefire rate were not limited by gas flow; decreasing the flow by a factor of two had no effect on the prefire rate. Even at the high flow rate used the flow was ineffective in keeping the arc debris off the walls, and a noticeable deposit built up on all wall types after a few thousand pulses, increasing the fraction of radiated energy absorbed and hastening thermal damage.

### Damage Mechanisms

The wall damage can be divided into three general categories, mechanical, thermal and electrical. Electrical problems, current leakage under the effect of tangential electric field,

accounted for only one failure mode; mechanical, thermal, and their combination accounted for all the others. The damaging thermal effects are gradually increasing temperature due to heat conducted from the gas and electrodes, flash heating of the surface, and thermal shocking; mechanical effects are from the pressure pulse of the arc column, the clamping pressure necessary to affect a gas-tight seal, surface deterioration from deposition of the arc debris and ablation, and bulk deterioration from absorption of the UV generated by the arc. Deposits on the wall surface can worsen the electric field effects by enhancing surface tracking or improve it by providing resistive grading; they can also worsen the thermal effects by increasing absorption of the energy radiated from the arc.

### Wall Materials

#### a. Acrylic:

The as-delivered spark gap used cast acrylic walls, 4.0 in. ID and 0.375 in. thick, and an uncooled center electrode. The progression of damage with increasing repetition rate and average power was darkening of the walls, shallow axial crazing in the line-of-sight region, surface melting of the crazed region, and finally softening and gross deformation of the wall edge in contact with the center electrode, as shown in Figure 4, whose temperature reached 133°C, well above the softening temperature for acrylic. At moderate and high average power there was a strong acrylic smell in the exhausted gas, probably from the dissociation of polymers into monomers on the inner wall surface. There was no evidence of electrical tracking over the surface or damage from the acoustic shocking. The wall discoloration was a soft, sooty brown deposit, presumably copper evaporated during the pulse and oxidized before reaching the walls. Any UV solarization of the acrylic was in a very shallow layer at the surface, as would be expected from the high attenuation of UV in acrylic. The walls were easily cleaned with mild abrasive cleanser and water. The arc associated with a prefire fault, during which the capacitor bank dumped and the power supply drove its short-circuit current through the spark gap until the main breaker cleared, was lower current but of much longer duration. This longer time allowed significant arc motion, often leaving a meandering track on the electrode surface up to 0.5 in. long, moving under the influence of magnetic and gas dynamic forces, predominantly away from the current feed. Where the errant arc attached itself to the electrode-wall interface, the result was a heavy deposit of metallic copper, strongly bonded to the wall surface.

These walls were satisfactory at very low average power, such that the thermal limitations were not reached. A liquid cooling coil was added to the center electrode to eliminate the heat loading conducted from it to the acrylic, and a new set of acrylic walls ran 10<sup>5</sup> shots without failure, although there was serious surface damage, a reduction of thickness by 0.025 in., and

slight deformation from the clamping pressure centered on the line-of-sight region. The upper wall, consistently the more damaged, is shown in Figure 5. A significant improvement noted in prefire rate is described above. A estimate of the remaining life in these walls under the conditions described is another 2 to 3 x 10<sup>5</sup> shots.

#### b. Transite:

This is an inexpensive asbestos-loaded Portland cement laminated insulator material frequently used for its high temperature capability and reasonable dielectric strength. The 4 in. pipe, from which these walls were made, is used for electrical conduit and sewer pipe. There was no gross thermal damage, although there was slight ablation of the wall and a small amount of the cement dust was present in the exhaust gas. Electrical performance was significantly worse than with acrylic, with many more prefires and system kickouts. The cause was found to be electrical leakage between the laminations, acting as an uncontrolled resistive divider between the center electrode and the two end electrodes, changing the voltage distribution from the intended 60/40 ratio. The small dark line on the edge of the cylinder near the spark plug in Figure 6 is one end of this leakage path. The asymmetry of the metal deposits from the magnetically-pushed long duration fault arc, and its metallic rather than oxidized appearance, are evident also.

#### c. Composite Walls:

To capitalize on the good electrical properties of acrylic and the thermal properties of Transite, a composite wall was made from a 1.0 in. ring of Transite joined to an acrylic wall with a cylindrical step-joint. The Transite rings needed external metal reinforcing bands to maintain physical integrity because the presence of the holes for the spark plugs reduced the cross section of the ring by over 50 percent. Figure 7 shows these walls after 144,000 pulses at 8 kJ and 0.4 C with a prefire rate of approximately 5x10<sup>-4</sup>, equivalent to the acrylic walls alone. The major damage evident is the crack in the Transite, which occurred before the metal bands were applied, and the wearing away of the Transite around the crack from ablation and the scrubbing action of the gas flow. These walls were still servicable when shut down.

The Transite rings are inherently weak, and the machining necessary to join the materials makes the composite no longer inexpensive, but this wall gave satisfactory results at 0.24 Mw average power for 15 s burst length for hour-long runs.

#### d. Fused Silica:

Except for its cost, fused silica offered many potential advantages: good electrical properties, excellent thermal capability, fair

mechanical strength, and UV transmission which allowed placing the pre-ionizing UV source, the spark plugs in this case, outside the gap envelope. With 0.187 in. thick fused silica walls the gap ran for much of one day at 0.32 Mw for many minutes at a stretch, with a total pulse count of 43,000 pulses and a prefire rate of 4x10<sup>-4</sup>. Enough heat was deposited in the center electrode to slightly blue it, but there was no apparent damage to the walls. The next day, however, after a few seconds at low repetition rate and no kick-outs, the upper wall exploded. Autopsy showed no sign of the 45° angular cracking characteristic of fused silica which has been thermally abused, but that some of the knockout arc spots had migrated to the wall-center electrode interface. A little known characteristic of fused silica is its disparity between short-term and long-term mechanical strength<sup>1</sup>, due to the slow propagation of surface microcracking through its volume. The postulated failure mode is that one of the knockout arcs near the wall, see Figure 8, created surface cracking which, over a few hours, propagated through the wall, weakening it sufficiently that the pressure pulses from normal operation the following day broke it. The presence of grinding marks from the fabrication of the walls may have exacerbated the surface problem.

#### e. Pyrex:

After 5 x 10<sup>4</sup> pulses with a cooled center electrode, the Pyrex walls show no damage except deposits of electrode material, and the prefire rate is better than 10<sup>-4</sup>, as was acrylic with the cooled electrode. There have been no prefire/kickouts in which the arc attachment spot migrates to the wall interface, and it remains to be seen whether the Pyrex can withstand it. While Pyrex cuts off considerably more of the UV than does fused silica, enough gets through, along with the visible, to make an external source effective in stabilizing the triggering of the gap.

#### Conclusions

The spark gap insulator wall operates in a harsh electrical, thermal and mechanical environment. To ensure wall survival without resorting to exotic or expensive materials, this environment can be modified by shielding the wall from debris, deposits, and radiated energy; by liquid cooling of electrodes; and by preventing the arc from moving against the wall surface. A composite wall, where different materials are used to do different parts of the insulator function, is a viable approach.

#### Acknowledgment

The author would like to acknowledge the assistance of J. Tomaini of ERADCOM, who did most of the actual work reported here.

#### Reference

1. Private communication, N. Reinhardt, Impulse Electronics.

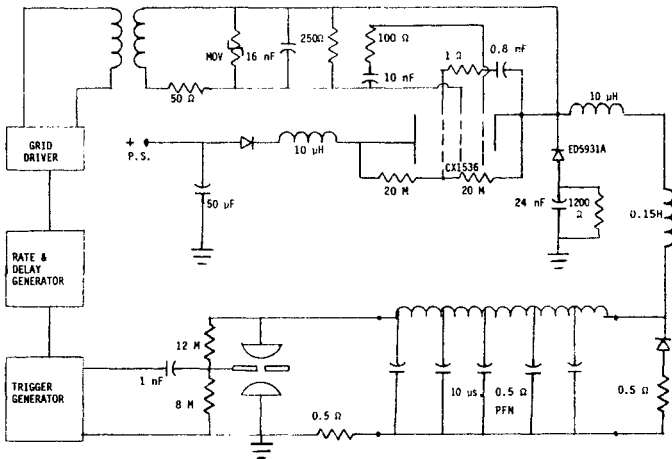

Figure 1 Pulse Charging Circuit, Schematic

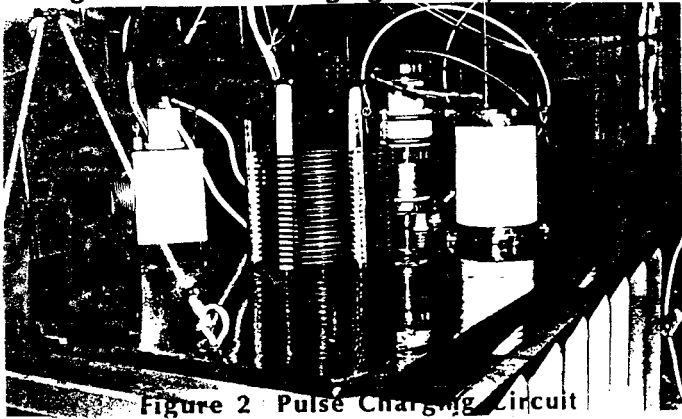

Figure 2 Pulse Charging Circuit

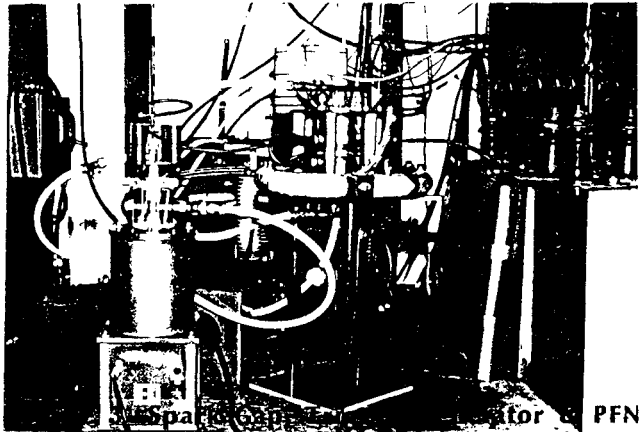

Figure 3 Pulse Charging Circuit

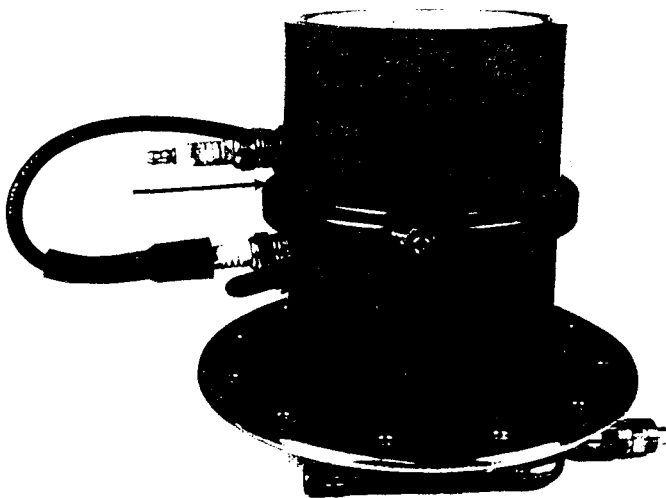

Figure 4 Deformed Acrylic Wall

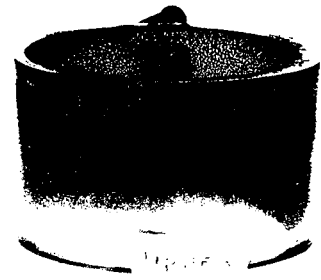

Figure 5 Acrylic Wall Cooled Electrode



Figure 6 Transite Wall Leakage Path

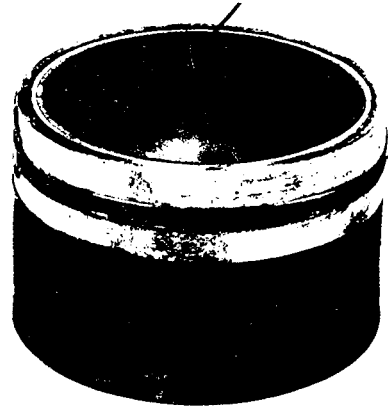

Figure 7 Transite-Acrylic Composite Wall



Figure 8 Fused Silica Wall Showing Kickout Arc Spot