

POWER FLOW ENHANCEMENT IN THE BLACKJACK 5 PULSER
(BLACKJACK 5')*

A. Richard Miller
Maxwell Laboratories, Inc.
8835 Balboa Avenue
San Diego, California 92123

Abstract

A modification of the 0.6 Ω , 10 TW BLACKJACK 5 pulser has reduced its output impedance to 0.3 Ω without a commensurate increase in pulser diameter. This new configuration is named BLACKJACK 5' and demonstrates "convoluted power flow" concepts as applied to coaxial water dielectric pulse lines. In this modification, a dual pulseforming line and ground plane shielded output switch provides the initial power flow convolution and the resultant parallel power flow is subsequently recombined in the diode. While ultimate performance is limited by the unaltered stages of BLACKJACK 5, initial tests have shown the increase in peak output power to be 20 percent greater than that from BLACKJACK 5 at the same operating level. Delivered energy will be >0.5 MJ at a power level of 10 TW. Further application of this technique should permit power levels approaching 25 TW from this single pulser module.

Introduction

A variety of water dielectric pulse lines exist, the configurations of which reflect different approaches to an ultimate electrical performance goal of the production of output power pulses at levels approaching a PW (10^{15} W). The various designs can be viewed as topological deformations of some common, generalized set of conductors where differences of scale and configuration offer different technological and system advantages. In all cases the breakdown stresses of available dielectric materials place severe limits on power flux densities and dictate a linear scaling of dimensions transverse to the power flow as total output power requirements increase. Insofar as practical limits dictate the size of a single power source, modular concepts become attractive. However, modules are ultimately a piecemeal approximation to some continuous structure wherein the basic power flow limitations still apply. Module size is determined by a compromise between technological (e.g. breakdown stress) and pragmatic (e.g. manufacturable design) issues and typical modules fall short of desired total power levels. Modularization sets in below power flux convergence determined limits and the power convergence problem is transferred to the beam power transport or converter schemes which combine the module outputs. Given the degree of convergence from these extended sources to typical loads, the variety of pulser concepts is not surprising.

One approach, while limited in applicability to final systems of the order of 100 TW, has evolved a 10 TW coaxial module capable of further development to the 25 TW level. The first step in this development is described below.

Discussion of BLACKJACK 5'

A criterion of technological growth is improvement of some figure of merit with time. Two years ago, at this pulse power conference, I presented a review of the evolution of a class of coaxial, terawatt level, low impedance pulse generators¹. At that time BLACKJACK 5 was operational at power levels up to 10 TW. In the preceding decade the improvement in output power capability was shown to have increased more than tenfold and a conceptual scheme for continuing this growth was introduced. That power flow enhancement scheme is termed "Convoluted Power Flow". It has been successfully tested and will be discussed here.

As it was the basis for BLACKJACK 5', I begin by reviewing the BLACKJACK 5 pulser shown in Figure 1. This is a typical coaxial pulser driven by a Marx generator as the primary energy source. The water insulated pulse forming line provides wave shaping and power gain and a vacuum insulated diode couples the power pulse to the load.

That the energy storage and power flow in this pulseline is confined to a narrow annular region is more clearly shown in Figure 2. This is a schematic cross-section of the pulseline. Power gain is achieved through sequential transfer of energy from stage to stage in progressively shorter times.

Energy is stored transiently in, and power flow is through, annular regions at the large radii which are required for breakdown free operation at high voltage and low impedance.

Consequently, much of the internal volume goes unused. Self-closing multi-channel switches are used at each stage.

Additional energy can be stored, and a second parallel path for power flow established in the interior of this pulser structure provided there is some means for coupling the two separate pulsers thus formed. Ground plane shielded switching, as first developed at SANDIA National Laboratories², provides the means for accomplishing this. These internal additions are the basis for BLACKJACK 5' and are shown in Figure 3.

As the first step in this technology development effort, only the output section of BLACKJACK 5 has been modified as shown. Two parallel output transmission lines were installed, the inner being slightly higher impedance, giving a net parallel impedance of 0.3 Ω . Driving this is a folded pulse forming line stage which is half-coax half-radial transmission line. As charged by the previous stage this is a 100 ns, 0.75 Ω line.

* Work Supported by the Defense Nuclear Agency
Contract No. DNA001-79-C-0019.
DFOISR Case Numbers 0404.

Report Documentation Page

Form Approved
OMB No. 0704-0188

Public reporting burden for the collection of information is estimated to average 1 hour per response, including the time for reviewing instructions, searching existing data sources, gathering and maintaining the data needed, and completing and reviewing the collection of information. Send comments regarding this burden estimate or any other aspect of this collection of information, including suggestions for reducing this burden, to Washington Headquarters Services, Directorate for Information Operations and Reports, 1215 Jefferson Davis Highway, Suite 1204, Arlington VA 22202-4302. Respondents should be aware that notwithstanding any other provision of law, no person shall be subject to a penalty for failing to comply with a collection of information if it does not display a currently valid OMB control number.

| | | | |
|---|------------------------------------|--|--|
| 1. REPORT DATE JUN 1983 | 2. REPORT TYPE N/A | 3. DATES COVERED - | |
| 4. TITLE AND SUBTITLE Power Flow Enhancement In The Blackjack 5 Pulser (Blackjack 5') | | 5a. CONTRACT NUMBER | |
| | | 5b. GRANT NUMBER | |
| | | 5c. PROGRAM ELEMENT NUMBER | |
| 6. AUTHOR(S) | | 5d. PROJECT NUMBER | |
| | | 5e. TASK NUMBER | |
| | | 5f. WORK UNIT NUMBER | |
| 7. PERFORMING ORGANIZATION NAME(S) AND ADDRESS(ES) Maxwell Laboratories, Inc. 8835 Balboa Avenue San Diego, California 92123 | | 8. PERFORMING ORGANIZATION REPORT NUMBER | |
| 9. SPONSORING/MONITORING AGENCY NAME(S) AND ADDRESS(ES) | | 10. SPONSOR/MONITOR'S ACRONYM(S) | |
| | | 11. SPONSOR/MONITOR'S REPORT NUMBER(S) | |
| 12. DISTRIBUTION/AVAILABILITY STATEMENT Approved for public release, distribution unlimited | | | |
| 13. SUPPLEMENTARY NOTES See also ADM002371. 2013 IEEE Pulsed Power Conference, Digest of Technical Papers 1976-2013, and Abstracts of the 2013 IEEE International Conference on Plasma Science. Held in San Francisco, CA on 16-21 June 2013. U.S. Government or Federal Purpose Rights License | | | |
| 14. ABSTRACT A modification of the 0.6 n, 10 TW BLACKJACK 5 pulser has reduced its output impedance to 0.3 n without a commensurate increase in pulser diameter. This new configuration is named BLACKJACK 5' and demonstrates "convoluted power flow" concepts as applied to coaxial water dielectric pulse lines. In this modification, a dual pulseforming line and ground plane shielded output switch provides the initial power flow convolution and the resultant parallel power flow is subsequently recombined in the diode. While ultimate performance is limited by the unaltered stages of BLACKJACK 5, initial tests have shown the increase in peak output power to be 20 percent greater than that from BLACKJACK 5 at the same operating level. Delivered energy will be >0.5 MJ at a power level of 10 TW. Further application of this technique should permit power levels approaching 25 TW from this single pulser module. | | | |
| 15. SUBJECT TERMS | | | |
| 16. SECURITY CLASSIFICATION OF: | | | 17. LIMITATION OF ABSTRACT SAR |
| a. REPORT unclassified | b. ABSTRACT unclassified | c. THIS PAGE unclassified | |
| | | | 18. NUMBER OF PAGES 4 |
| | | | 19a. NAME OF RESPONSIBLE PERSON |

MLA-4260

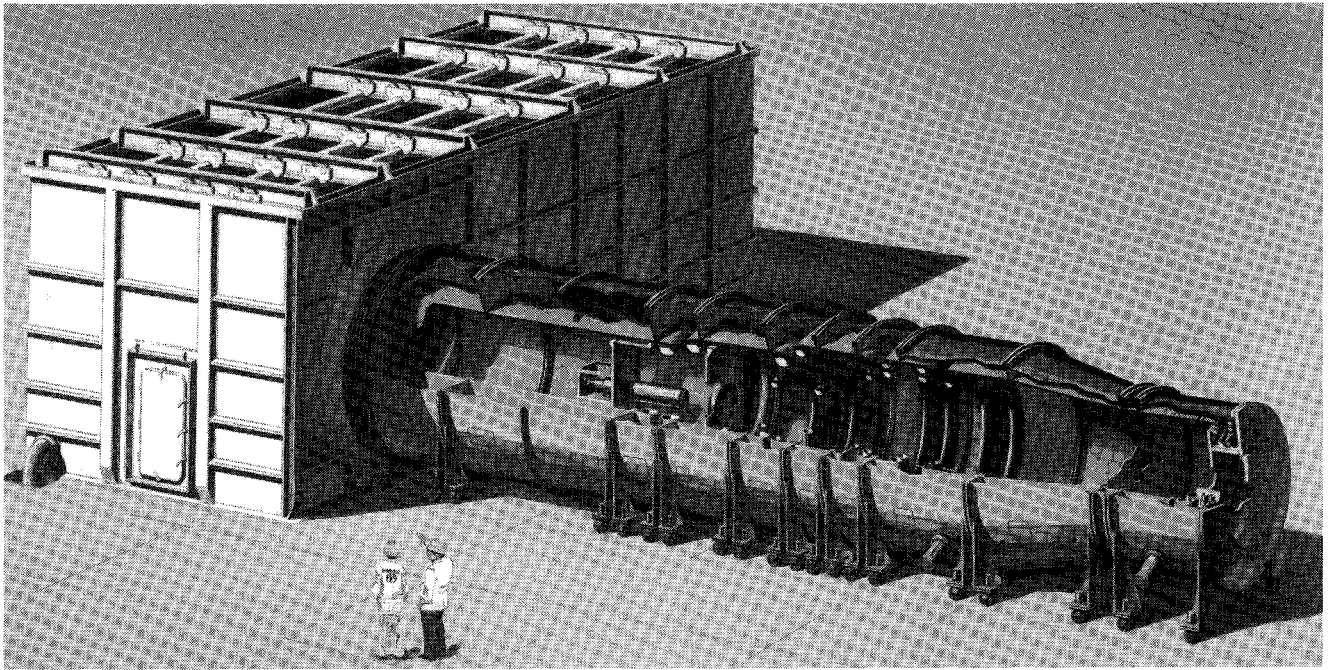

Figure 1. BLACKJACK 5, 10 TW pulser

When switched out in the middle, its output impedance is reduced to $\sim 0.4 \Omega$ and it delivers a 50 ns pulse to the dual transmission lines. The ground plane through the switch region ensures continuity of current flow on the inner ground conductors.

Power flow division is determined by the impedances. Recombination of the power flow occurs in the diode through "posthole" convolutes.

Maximum attainable performance is limited by the as yet unaltered preceding stages of the pulser. However, as shown in Figure 4, tests up to 8.5 TW demonstrate an enhancement over BLACKJACK 5 by approximately 20 percent.

A complete revision of the pulser, extending the parallel concept back to the Marx, would give 25 TW power levels.

Operational Testing

Testing of BLACKJACK 5' confirmed the importance of two effects; first, energy, and therefore, power losses are caused by the change in capacitance produced by switch breakdown channel growth, and second peak power and delivered energy depend critically upon stage switch closure times.

Time varying capacitance effects were observed in the output switch as a reduction in peak attainable

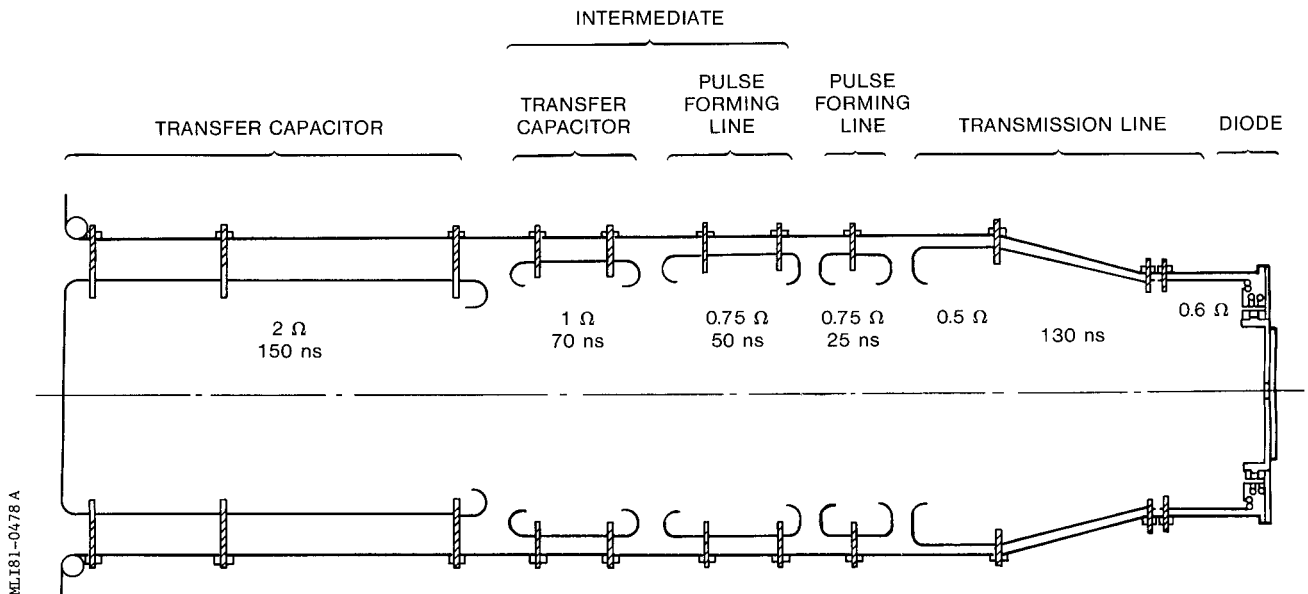

ML181-0478 A

Figure 2. BLACKJACK 5 pulser, cross section

pulse forming line voltage. The region of this effect is shown schematically in Figure 5. The hybrid pulse forming line, the dual transmission line, and the switch electrode extending through the ground plane are illustrated. Voltage probes are located as shown. Initial voltage measurements were well below predicted values and photographs showed streamers growing from the ground plane hole edges towards the PFL during the pulse. The locus of streamer tips define a considerable capacitance which varies with time as these streamers grow³. Grading

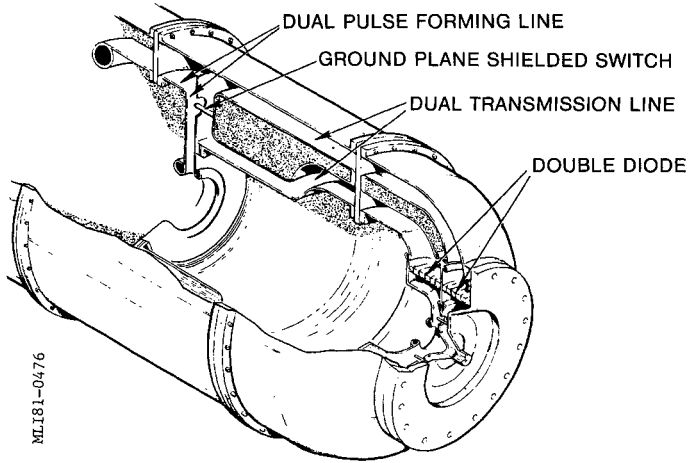

Figure 3. Cross section of BLACKJACK 5' modification

these edges caused the marked improvement shown in Figure 6. This is a plot of peak voltages measured at the radial line probe position as a function of output switch closure time. What is compared are the before and after grading results. The abrupt rise at about 50 ns is the arrival of the main charging pulse at the open circuit end of the radial line. The rolloff is due to the charging pulse wave shape and irreducible dc/dt loading by the switch. These effects are understood and are the subject of another paper at this conference⁴.

The rapid temporal variation of the PFL waveforms also implies the importance of switch timing. Simply put, one wants to maximize the power flow in the direction of the diode. Different rules pertain to the selection of optimum switch firing times according to whether one is charging and switching a pulse forming line which either performs as a capacitor or as a transmission line. Selection of optimum switch firing time for transmission line-like stages is covered by papers on "double bounce" at this conference^{5,6}. In this case, noting that we switch out in the middle of the line, the optimum is a variant of double bounce and is about 125 ns.

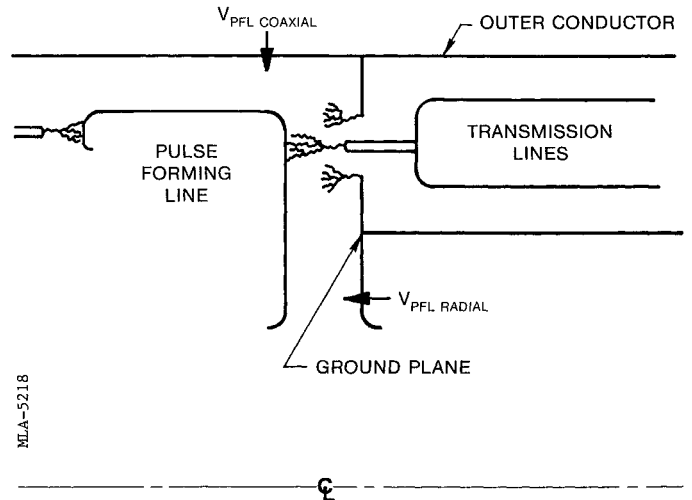

Figure 5. Output switch region of BLACKJACK 5', showing location of breakdown streamers

Optimum times for the more slowly charged capacitor-like stages are given by the rule that a switch should close three transit times of the switched line prior to the time of peak voltage on that line where the time is measured from the closure time of the preceding switch.

Finally, the optimum switch times for peak power and peak energy do not coincide as shown in Figure 7 where the variation of peak power and delivered energy with switch closure time is illustrated. Note that peak power is attained for switch closure times which are later than those which give peak energy.

Summary

Power flow studies and operational tests demonstrate this "convoluted power flow" concept. Extrapolation of present operating levels leads to a nominal 12 TW output power at maximum Marx energy delivered to the BLACKJACK 5' pulser and further testing is planned.

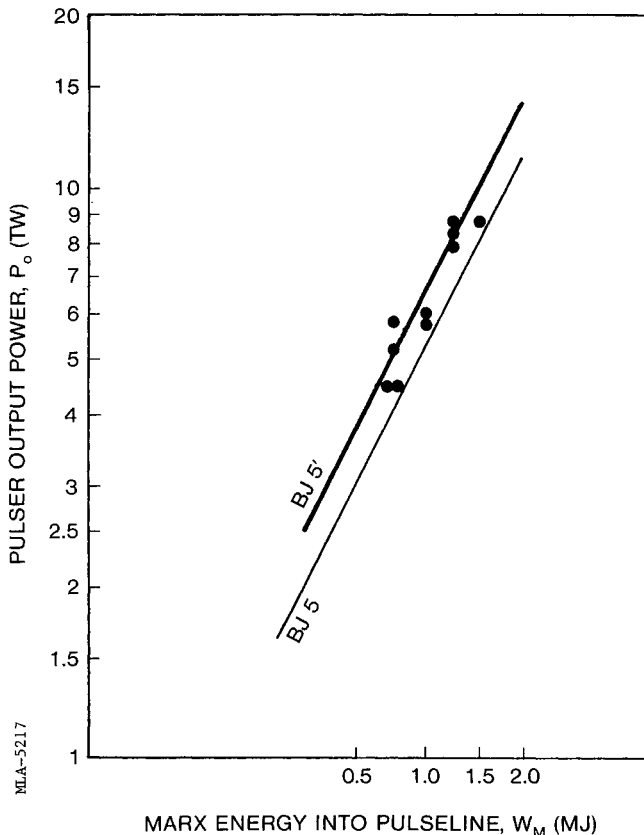

Figure 4. BLACKJACK 5', variation of output power vs. input energy

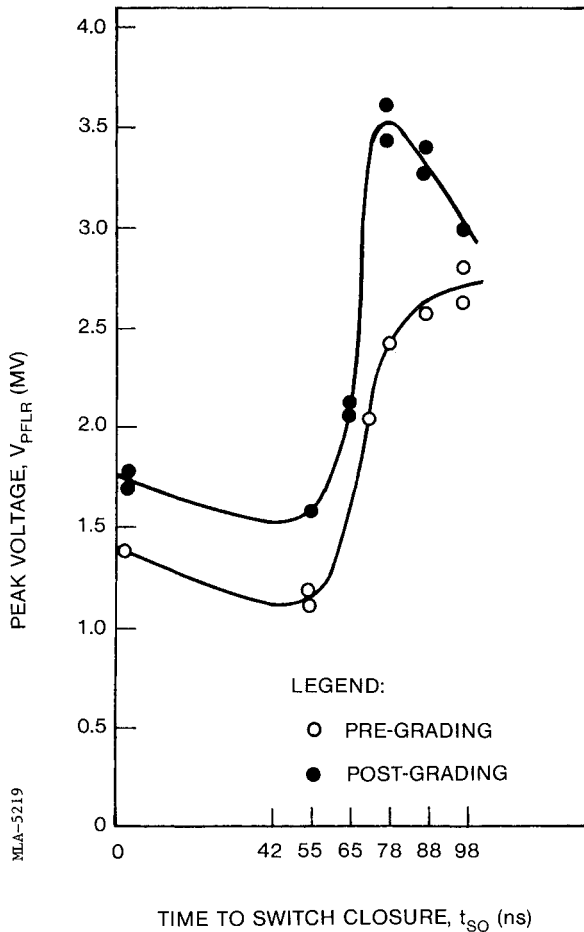

Figure 6. Variation of measured peak voltage at radial line probe position as a function of switch closure time, before and after grading (timing scan at $0.4 \hat{P}_o$)

This configuration is to be viewed as a volume efficient means of paralleling two coaxial pulselines where synchronism is assured by virtue of switches common to both pulsers. At this point only the performance of the front end has been demonstrated. A reconfiguration of the remainder of the structure would increase the module output power to 25 TW. Beyond this, additional convolutions would have a minimal effect at the expense of much greater complexity. Further increase in module power could only be achieved by larger diameters. Taking the present four meter diameter as an approximate limit on manufacturability, the asymptotic limit on power from this module is seen to be 25 TW. Applicability of this module to far term system goals of 100 TW is thus seen to be limited by the difficulty of combining the outputs of large coaxial modules and the size and cost of such a system. Its future usefulness is in supporting near term testing and the development of scaling relationships for technological issues common to it and larger machines.

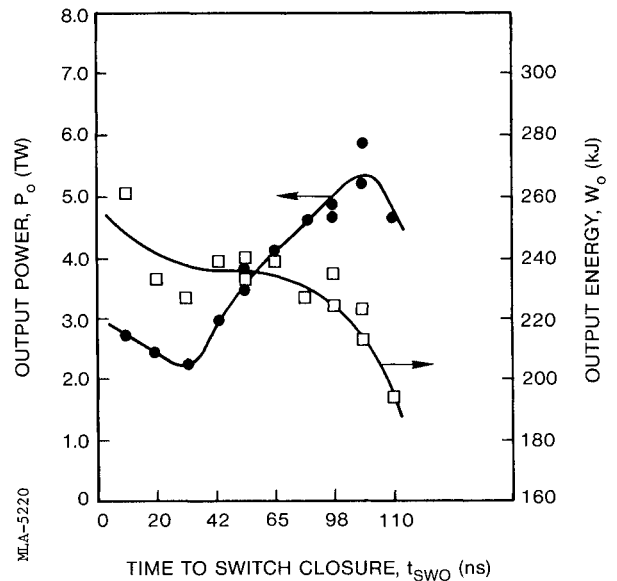

Figure 7. Variation of peak power and pulse energy with output switch closure time (timing scan at $0.4 \hat{P}_o$)

Acknowledgement

Support of the Defense Nuclear Agency and guidance from Mr. Jonathan Z. Farber and Major Hounq Soo is thankfully acknowledged. Moreover, the contributions of Maxwell staff and staff support personnel are to be recognized. In particular, the efforts of the BLACKJACK facility crew in successfully putting this pulser together on schedule are to be commended.

References

1. A. R. Miller, "Sub-Ohm Coaxial Pulse Generators, BLACKJACK 3, 4, and 5'," 3rd IEEE Int. Pulsed Power Conference, Albuquerque, NM (June 1981).
2. D. L. Johnson, J. P. VanDevender and T. H. Martin, "Low Prepulse, High Power Density Water Dielectric Switching," 2nd IEEE Int. Pulsed Power Conference, Lubbock, TX (June 1979).
3. E. F. Kelley, R. E. Hebner, Jr., "The Electric Field Distribution Associated with Prebreakdown Phenomena in Nitrobenzene," J. Appl. Phys., 52 (1), June 1981.
4. G. M. Wilkinson, "Time-Dependent Capacitance Effects in Water Dielectric Switching," 4th IEEE Pulsed Power Conference, (June 1983).
5. G. B. Frazier, "Double Bounce Switching," 4th IEEE Pulsed Power Conference, (June 1983).
6. A. Kuchler, T. Dunz, J. Dams, A. J. Schwab, "Power and Voltage Gain of Pulse-Forming Lines With Double-Bounce Switching," 4th IEEE Pulsed Power Conference, (June 1983).