

EAGLE AND DOUBLE-EAGLE*

G.B. Frazier, S.R. Ashby, L.J. Demeter, M. Di Capua,
J. Douglas, S.C. Glidden, H.G. Hammon, III; B. Huff, S.K. Lam,
A. Rutherford, R. Ryan, P. Sincerny, and D.F. Strachan

Physics International Company
2700 Merced Street
San Leandro, California 94577

Abstract

EAGLE and Double-EAGLE are high-power, Marx-generator-driven, water-dielectric, low-impedance pulse generators. EAGLE was a research test bed. It was built and tested as a prototype module for large accelerators. These large accelerators (called ROULETTE machines) can be built by arranging EAGLE modules into a circle surrounding a central load region. Double-EAGLE (now under construction) is the first example of such a machine. It will use two, horizontally-opposed EAGLE modules to drive a circular vacuum tube feeding dual-MITL's. Design parameters are 0.3 ohms, 7 TW, 0.5 MJ, 75 ns (FWHM power). Double-EAGLE will be a radiation simulator using either imploded-plasma sources or particle beam diodes. Design data for the machine came from EAGLE experiments which addressed high-power, low-jitter switching in both gas and water, and short-pulse water breakdown. In checking out EAGLE, we measured peak output pulse parameters of 4.6 ± 0.5 TW, 1.6 MA, 275 kJ, 75 ns (FWHM power) into a 1.9 ohm resistive load. We discuss results from these EAGLE experiments, describe the design and construction status of Double-EAGLE, and briefly comment on ROULETTE conceptual designs.

Introduction

EAGLE and Double-EAGLE are elements of a Defense Nuclear Agency program to enhance our national capability for above-ground nuclear weapons effects testing¹. Over the past two years, interest in using laboratory simulators for above-ground tests (AGT) has increased. This increased interest comes at an opportune time technically. Over 10 years of pulsed-power research in super-power generators²⁻¹¹ has provided us with a good technology base for expanding our capabilities in AGT.

The EAGLE/Double-EAGLE Program seeks to satisfy the increased demand for AGT by extending the pulsed power driver technology necessary for radiation-producing loads. Two types of load are particularly important: megavolt electron Bremsstrahlung (MEB), and imploding plasmas^{12,13}. Both types of load require low impedance generators so that output voltages are kept "low," between about 1-3 MV. Thus, the trend is toward higher current generators. This trend is especially important for imploded plasmas because radiation yields scale strongly with current¹⁴.

The need to keep output voltage constant even as machines grow larger requires the development of an extendable, low-impedance generator tech-

nology. The technical approach to this requirement in the EAGLE/Double-EAGLE Program has been to develop modular, Marx-generator-driven, water-dielectric pulse forming modules which can be used as building blocks for large machines. The flow of this technical approach is illustrated in Figure 1. The starting point was ROULETTE-X, a conceptual point-design for a generator with pulse parameter targets of 40-50 TW, 4-5 MJ, 20-22 MA, 2-2.5 MV, 100 ns FWHM power (EAGLE data suggest actual pulse parameters would be closer to 70 TW, 5 MJ, 75 ns). We used the ROULETTE-X design to establish performance objectives for EAGLE.

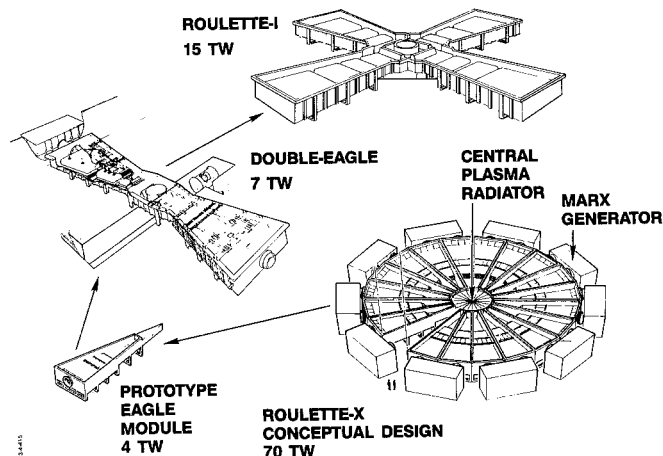

Figure 1. The ROULETTE family. ROULETTE-X was the conceptual starting point. EAGLE was a prototype testbed. Double-EAGLE (under construction) is the first working simulator. ROULETTE-1 is a candidate step beyond Double-EAGLE.

EAGLE is a prototype for one of the 20 modules that comprise ROULETTE-X. We built EAGLE to: 1) demonstrate output performance consistent with ROULETTE-X objectives; 2) establish quantitative performance objectives for Double-EAGLE, the next step in the progression shown in Figure 1; 3) gather design data for Double-EAGLE and validate design techniques (such as computer modeling); 4) demonstrate a low enough system jitter to ensure synchronous operation of the two modules in Double-EAGLE; and 5) evaluate new ideas for improving pulsed power technology.

We addressed the EAGLE research objectives in an experimental program conducted between 1 May

*Work sponsored by the Defense Nuclear Agency.

Report Documentation Page

Form Approved
OMB No. 0704-0188

Public reporting burden for the collection of information is estimated to average 1 hour per response, including the time for reviewing instructions, searching existing data sources, gathering and maintaining the data needed, and completing and reviewing the collection of information. Send comments regarding this burden estimate or any other aspect of this collection of information, including suggestions for reducing this burden, to Washington Headquarters Services, Directorate for Information Operations and Reports, 1215 Jefferson Davis Highway, Suite 1204, Arlington VA 22202-4302. Respondents should be aware that notwithstanding any other provision of law, no person shall be subject to a penalty for failing to comply with a collection of information if it does not display a currently valid OMB control number.

1. REPORT DATE JUN 1983	2. REPORT TYPE N/A	3. DATES COVERED -	
4. TITLE AND SUBTITLE Eagle And Double-Eagle		5a. CONTRACT NUMBER	
		5b. GRANT NUMBER	
		5c. PROGRAM ELEMENT NUMBER	
6. AUTHOR(S)		5d. PROJECT NUMBER	
		5e. TASK NUMBER	
		5f. WORK UNIT NUMBER	
7. PERFORMING ORGANIZATION NAME(S) AND ADDRESS(ES) Physics International Company 2700 Merced Street San Leandro, California 94577		8. PERFORMING ORGANIZATION REPORT NUMBER	
9. SPONSORING/MONITORING AGENCY NAME(S) AND ADDRESS(ES)		10. SPONSOR/MONITOR'S ACRONYM(S)	
		11. SPONSOR/MONITOR'S REPORT NUMBER(S)	
12. DISTRIBUTION/AVAILABILITY STATEMENT Approved for public release, distribution unlimited			
13. SUPPLEMENTARY NOTES See also ADM002371. 2013 IEEE Pulsed Power Conference, Digest of Technical Papers 1976-2013, and Abstracts of the 2013 IEEE International Conference on Plasma Science. Held in San Francisco, CA on 16-21 June 2013. U.S. Government or Federal Purpose Rights License			
14. ABSTRACT EAGLE and Double-EAGLE are high-power, Marxgenerator- driven, water-dielectric, low-impedance pulse generators. EAGLE was a research test bed. It was built and tested as a prototype module for large accelerators. These large accelerators (called ROULETTE machines) can be built by arranging EAGLE modules into a circle surrounding a central load region. Double-EAGLE (now under construction) is the first example of such a machine. It will use two, horizontallyopposed EAGLE modules to drive a circular vacuum tube feeding dual-MITL's. Design parameters are 0.3 ohms, 7 TW, 0.5 MJ, 75 ns (FWHM power). Double-EAGLE will be a radiation simulator using either imploded-plasma sources or particle beam diodes. Design data for the machine carne from EAGLE experiments which addressed high-power, lowjitter switching in both gas and water, and shortpulse water breakdown. In checking out EAGLE, we measured peak output pulse parameters of 4.6 Â± 0.5 TW, 1.6 MA, 275 kJ, 75 ns (FWHM power) into a 1.9 ohm resistive load. We discuss results from these EAGLE experiments, describe the design and construction status of Double-EAGLE, and b			
15. SUBJECT TERMS			
16. SECURITY CLASSIFICATION OF:			17. LIMITATION OF ABSTRACT
a. REPORT unclassified	b. ABSTRACT unclassified	c. THIS PAGE unclassified	SAR
			18. NUMBER OF PAGES 7
			19a. NAME OF RESPONSIBLE PERSON

1981 and 28 January 1983. All objectives were met. Our design calculations predicted that we could deliver a 3.8 TW, 1.4 MA, 2.8 MV, 230 kJ, 95 ns pulse into a 2 ohm resistive load. The measured output performance of 4.6 ± 0.5 TW, 1.6 MA, 3.0 MV, 275 kJ, 75 ns (FWHM power) exceeded our design predictions. We established a firm data base for Double-EAGLE, and all our design techniques were validated. We measured a total system jitter of < 5 ns (1σ) with a statistical distribution that indicates the spread of arrival time between pulses from the two modules in Double-EAGLE will be well within acceptable limits.

Pulsed Power Experiments on EAGLE

To design Double-EAGLE, we needed data to answer three basic questions: 1) What are the water breakdown limitations throughout the system? 2) How must the switches and trigger systems be arranged to satisfy the Double-EAGLE synchronism requirement? 3) What kind of output pulse will the EAGLE modules be able to deliver to the Double-EAGLE load region? The data we present here are organized with these questions in mind. They fit into the categories: 1) water breakdown data; 2) switching and jitter experiments; and 3) waterline power flow characterization. We start with a brief review of the experimental apparatus, EAGLE.

The EAGLE Testbed

EAGLE has been described in previous publications^{2,11,15}. It is a Marx-generator-driven, water-dielectric pulse forming system. The Marx generator system has two 25-stage modules which collectively can store 650 kJ at ± 63 kV/stage for the nominal 4 TW operating level. The Marx generators charge a 100 nF water transfer capacitor (TC) to about 3 MV in 1.3 μ s. Power flow down the waterlines is illustrated by the voltage waveforms in Figure 2. An externally triggered gas switch (TGS)^{16,21} allows the TC to charge the second pulse compression stage, the charging pulseline (CPL). The CPL is switched out in about 300 ns by a set of self-closing, multi-site, field-enhanced water switches^{2,20} to charge the final pulse compression stage, the pulse forming line (PFL). The PFL is switched into an output line (OL) by a second set of self-closing water switches^{2,20} in < 100 ns. The output pulse is dissipated in a set of liquid resistors mounted at the end of the OL. Load resistance was 1.9 ohms, except during the OL water breakdown experiments.

To measure voltage and current throughout the pulse forming system, we installed 40 individual sensors. Current monitors in the flat-plate waterlines were single-turn B-dot loops located in the capacitive voltage monitors. We measured load current with full-circle Rogowski coils surrounding ground electrodes on each of the five liquid resistors comprising the load. The five signals were added to obtain total current.

We used two types of voltage monitors, one capacitive and one resistive. We designed the resistive monitors with a variable length to accommodate changes in transmission line spacings¹⁷. Signals from the EAGLE monitors were processed using two separate data acquisition systems. The first was a local system using an LSI-11 and CAMAC for routine recording of peak voltage on each pulse compression stage and for timing measurements of the three energy transfer

switches. The second system was PIDAS[®], a central PDP 11/34-Tektronix 7912 data acquisition system at PI which we used for acquisition and analysis of the output line and load voltage and current waveforms.

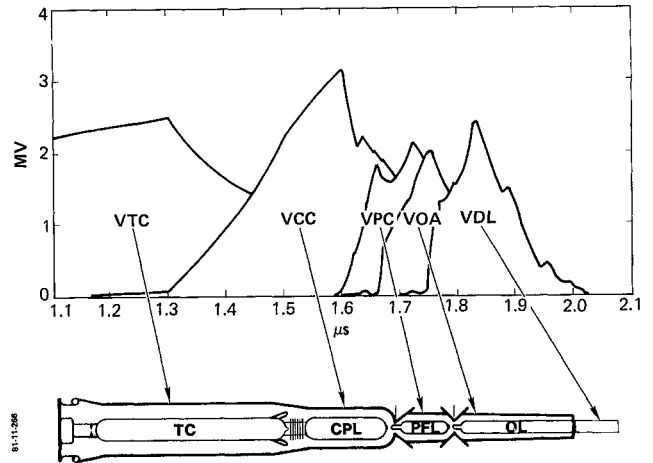

Figure 2. EAGLE voltage waveforms. Voltages for shot 137 were measured at the points indicated by the arrows.

Water Breakdown Data

To assess breakdown limitations in the Double-EAGLE design, we conducted two experiments on EAGLE. The first experiment took place as part of waterline power flow characterization. We fired EAGLE repeatedly at the Double-EAGLE spec-level (~ 4 TW per module) then tabulated the results as shown in Figure 3. Note the percent of breakdown at which each pulse compression stage in Double-EAGLE must operate to produce an output of about 7 TW. Percent of breakdown was determined from the ratio \bar{E}/F , where $\bar{E} = V/d$ in MV/cm, and F is the breakdown field in MV/cm as given by the standard formula¹⁸

$$F = 0.23 t^{-1/3} A^{-0.058}, \quad (1)$$

where t is the time (in microseconds) that pulses exceed 0.63 of their maxima, and A is electrode area in cm^2 . The CPL is the most highly stressed line, but it still falls within acceptable design criteria for a machine like Double-EAGLE. The PFL stress is reduced significantly by using the double-bounce switching technique¹⁹. The stresses indicated for the OL are not really relevant to Double-EAGLE because the OL will be replaced by a central coupler of different impedance.

We conducted our second breakdown experiment to confirm that Equation 1 is valid for the unusual output waveform produced by double-bounce switching (refer to Figure 7a). To make it easier to overstress the OL, we reduced its impedance to 1 Ohm and changed the load resistance to match the OL. The effective area of the OL (the area over which $\bar{E} > 0.9 \bar{E}_{\text{max}}$) was 4500 cm^2 ; t was 74 ns. For these parameters, Equation 1 gives $F = 335 \text{ kV/cm}$.

Our breakdown results agree with Equation 1 very well. We observed late-time breakdowns in the range $300 \text{ kV/cm} < E < 330 \text{ kV/cm}$. For $E \sim 340 \text{ kV/cm}$ breakdown occurred early enough to affect the main output pulse waveform. These results confirmed that Equation 1 was adequate to

use for designing the Double-EAGLE waterline coupler.

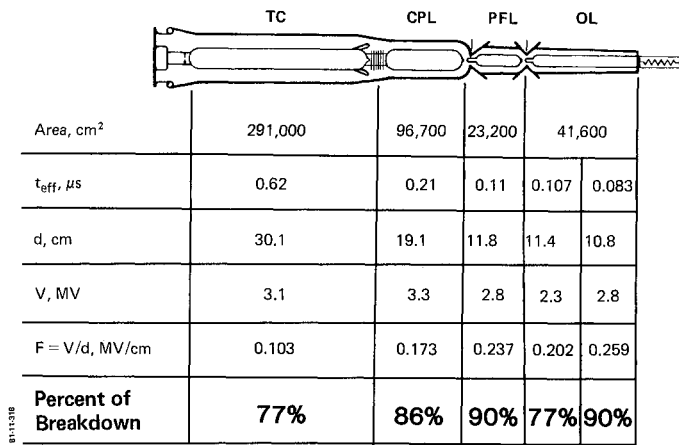

Figure 3. EAGLE waterline stresses at 4 TW. Voltage and average field maxima are given for shot 243.

Switching and Jitter Experiments

The high power switches in Double-EAGLE must shape the output pulse properly, protect the system in case of a fault, and ensure that the two modules are synchronized.

For protection, we used two sets of diverter switches, one for the TC, one for the OL. The TC diverters are particularly important. The TC diverters are necessary to protect the oil/water diaphragms and gas switch against high voltage "ringdown" in case the trigger system malfunctions. The diverters are self-closing water switches in series with a liquid resistor. The resistor helps to damp post-pulse oscillations on the TC (see Figure 4).

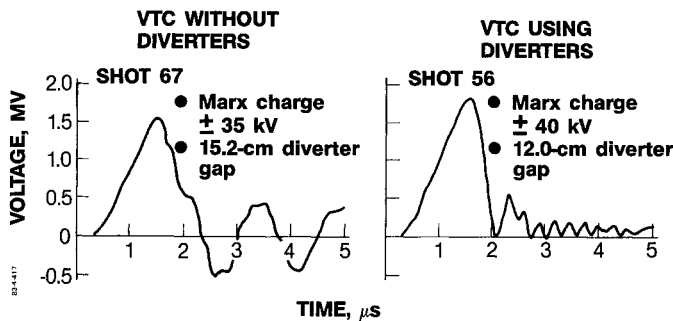

Figure 4. TC diverter switch action. Post-pulse oscillations on the TC are damped when diverters are used.

We accomplished pulse shaping with two sets of main water switches and a triggered gas switch. The two sets of main water switches in EAGLE both must operate with low jitter to ensure Double-EAGLE module synchronism. The CPL and PFL switches, respectively, exhibit 1 σ jitter of 2.5 ns and 2.7 ns at average voltages of 3.2 MV and 1.8 MV. Interestingly, the total jitter of the two water switches, the TGS, and trigger package is less than one would predict by adding the individual jitters in quadrature. This is because there is compensation between switches under real system conditions.

The triggered gas switch (TGS) and its associated trigger system will be the key to synchronous operation of Double-EAGLE (or any other member of the ROULETTE family). The switch has been described in previous publications^{2,16}. It consists of an eight-stage, UV-illuminated, multiple-electrode, electrically triggered SF₆ switch. It is triggered by an on-board pulse generator activated by a fiber optic link which enters the machine in the region of the CPL. Both the trigger system and two different versions of the TGS are described in separate publications^{16,21}. We present only the results relevant to the Double-EAGLE design here.

To determine whether Double-EAGLE synchronism requirements could be met by the EAGLE switching system, we conducted a series of tests to measure shot-to-shot reproducibility of the output pulse timing. We measured a shot-to-shot system jitter of < 5 ns for sustained operation at 4 TW. System jitter is defined as the standard deviation of t_d, the delay time between the low-level optical signal sent to activate the TGS trigger package and the injection of the output pulse into the OL. That includes jitter of both water switches, the TGS, and all components in the trigger package and control room. To determine whether measured jitter was low enough for Double-EAGLE, we had to take the statistical distribution into account. The important parameter for synchronism of multi-module machines is the spread in pulse arrival times at the point where module outputs are combined. For Double-EAGLE, we chose as a design goal to have > 70% of all shots with < 15 ns spread in arrival time. We used our measured values of t_d to see if this goal could be met.

Since the two modules of Double-EAGLE will be triggered simultaneously, and since the statistics of t_d for each module will be independent (the modules cannot interact until pulses are generated) we can use the shot-to-shot variation on EAGLE to predict the synchronism of Double-EAGLE. To do so, we tabulated all possible pairs of t_d values for each set of data (data set usually was about 30 shots, giving several hundred possible pairs of t_d values). Then we took the difference between t_d for each pair, Δt_d, and plotted the cumulative distribution of values, as shown in Figure 5.

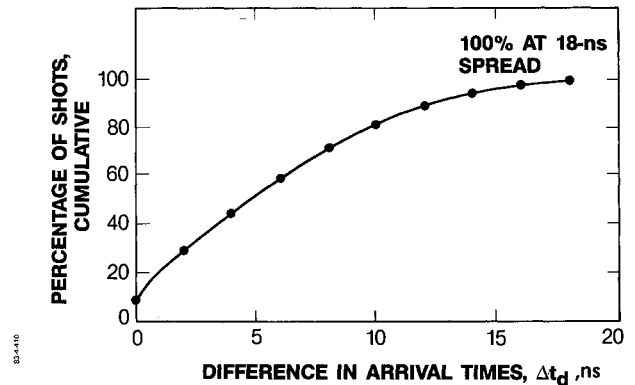

Figure 5. Double-EAGLE synchronism prediction. EAGLE shot-to-shot data is arranged in pairs to give Δt_d, the arrival-time differences.

The data show that 90% of the pairs had $\Delta t_d < 15$ ns, thereby significantly exceeding our design criterion of 70% with $\Delta t_d < 15$ ns. In fact, 80% in the pairs have $\Delta t_d < 10$ ns. Performance predictions for Double-EAGLE indicate that the distribution in arrival times we infer is more than adequate to meet specifications.

Waterline Power Flow Characterization

During our power flow characterization we sought to: 1) verify the accuracy of the computer modeling techniques we used to design Double-EAGLE; 2) estimate energy transfer efficiencies throughout the system; 3) investigate the double-bounce switching technique; 4) determine the extent to which the EAGLE output waveform can be varied; and 5) quantify the EAGLE output power and energy capabilities. Achieving these experimental objectives provided us with a design baseline for Double-EAGLE.

To validate our computer modeling techniques we compared predicted-to-measured voltage waveforms at several points in the waterline. Peak amplitudes are predicted to better than $\pm 10\%$ (within measurement error of the voltage monitors), and wave shapes are well represented on the computer even at late times. This agreement gave us high confidence in using the model to design Double-EAGLE.

Energy transfer efficiencies between stages in a fast-charged waterline system like EAGLE are difficult to measure experimentally. Figure 6 gives a tabulation of peak electrostatic energy ($1/2 CV^2$) delivered to each pulse forming element in EAGLE on a particular shot. The overall efficiency of 50% is unambiguous because it simply is the ratio of two well known quantities: DC Marx generator energy and energy dissipated in the load resistor. But the peculiar-looking transfer efficiencies between the CPL and load indicate a strong contribution of traveling wave energy in the PFL.

The electrostatic energy transfer efficiencies from the Marx generator to the TC (64%) and from the TC to CPL (87%) indicated in Figure 6 seem reasonable. The fact that less than 40% of the energy that eventually is delivered to the load appears as electrostatic energy in the PFL, however, means that over 60% of the energy flowing through the PFL was in the form of a traveling wave which did not increase the line voltage. This low-voltage operation of the PFL results from the double-bounce switching mode¹⁹ (a detailed discussion which is beyond the scope of this paper).

The double-bounce switching¹⁹ option not only provides us with a means to reduce PFL line and switch voltage, but also allows significant variation of the output wave shape. Figure 7 shows three different output waveforms (voltage across the load resistor) produced by varying output switch spacing over a factor of 2 at roughly constant machine power. The first waveform (7a) is unique to the double-bounce switching mode. Voltage rises to about 40% of its peak value in < 10 ns, then ramps to peak over about 90 ns. (This, incidently, is an excellent waveform for driving pure inductive loads such as imploded plasmas.) The other two waveforms (7b and 7c) progress toward a more conventional shape for a three-stage waterline machine. These examples show that we can vary pulse risetime (10-90%) from

45 to 70 ns, and pulse width (FWHM) from 120 to 155 ns at constant power by varying only the output switch spacing. This will be an advantage in tailoring the Double-EAGLE output pulse to fit various load conditions.

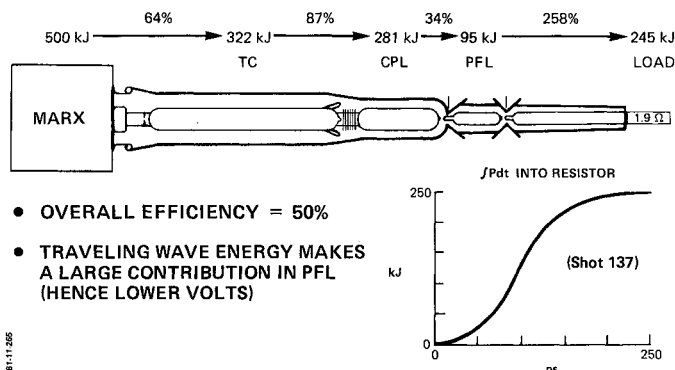

Figure 6. EAGLE energy transfer efficiencies. The electrostatic ($1/2 CV^2$) energy for each stage is shown for shot 137. Load energy came from the integral shown in the inset. The low value for PFL electrostatic energy is achieved by double-bounce switching.

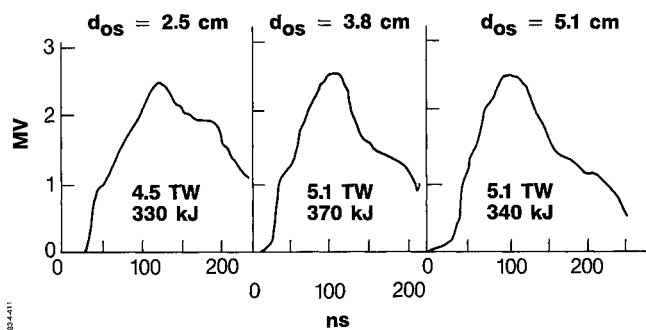

Figure 7. Output waveshape variability. The shape of voltage across the load is varied by changing PFL switch spacing. The shapes vary from double-bounce switching (7a) to conventional switching waveforms (7c).

The final data point we needed to design Double-EAGLE was the maximum output power capability for each module. The nominal output pulse parameters we measured are 4.6 ± 0.5 TW, 1.6 MA, 275 kJ, 75 ns (FWHM power) into 1.9 ohm resistive load. Figure 8 shows output waveforms for a shot at the high end of the measured range. Peak power is 5.1 TW. We chose to design Double-EAGLE for operation at 4 TW per module to provide a margin for safety.

Double-EAGLE Design

The EAGLE experimental program provided us with a firm design for the modular drivers of Double-EAGLE. The Double-EAGLE design approach is to use two modules to drive a single load. The outputs of the two modules will be combined into a single axisymmetric tube with double-sided power flow. We will merge the double-sided power flow through a magnetically insulated vacuum convolute when driving plasma loads. Since the module design essentially was established, the primary

focus of Double-EAGLE design was on the question of how to combine module outputs and merge them into a single load. The performance goals for the Double-EAGLE generator are summarized in Figure 9. An artist's rendering of the generator is shown in Figure 10.

SHOT 255

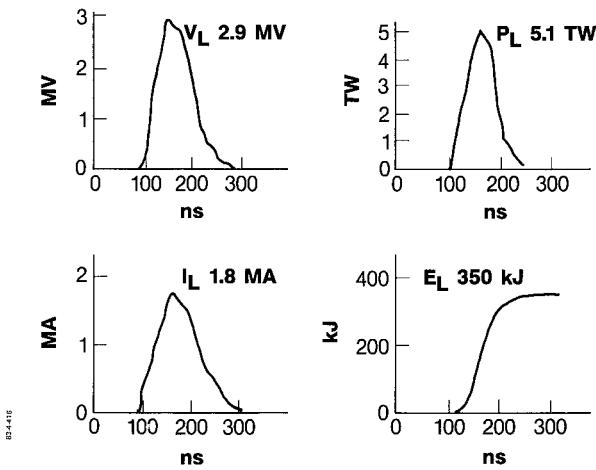

Figure 8. Output waveforms at 5.1 TW. Voltage, current, power, and energy for a maximum power shot on EAGLE are shown.

Power injected into tube	7 TW
Pulse width (FWHM power)	75 ns
Tube voltage	1.7 MV
Tube current	5.4 MA

Figure 9. Performance goals for Double-EAGLE. Tube voltage and current values apply to an imploded plasma load.

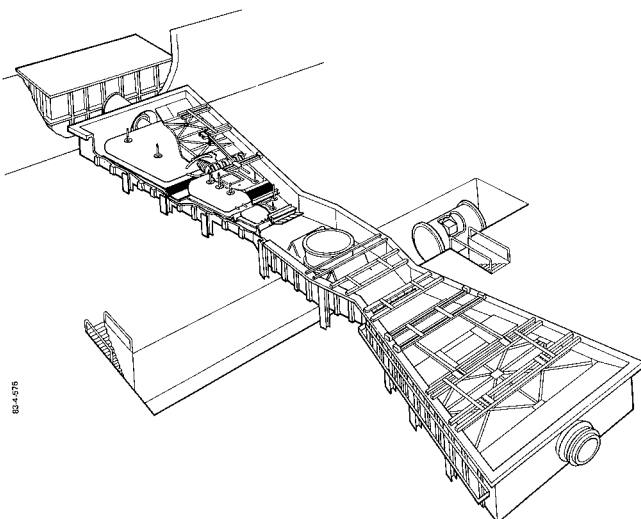

Figure 10. Artist's rendering of the Double-EAGLE generator.

Transit-Time Equalizer

The primary difficulty associated with the design of the Double-EAGLE generator has been how to maximize the azimuthal uniformity of the current delivered to the magnetically insulated feeds of the tube. As shown in Figure 11, the high wave propagation velocity in the vacuum, relative to water, produces significant non-uniformities in the currents flowing in the vacuum feeds of a tube driven with plane waves from two sides. In fact, in those sections of the tube which are at 90° to the incident wave directions, the current actually flows outward early in the

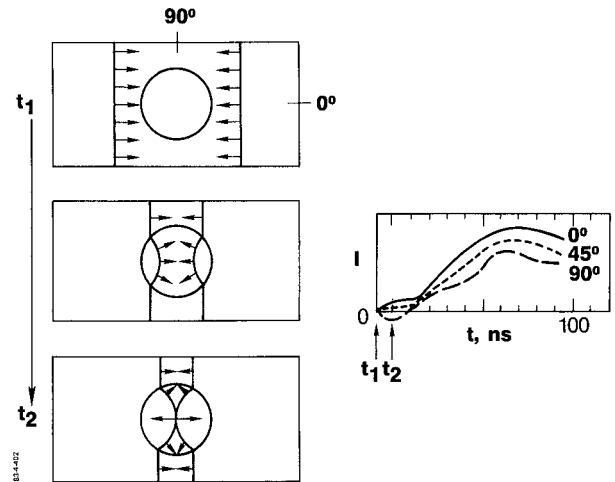

Figure 11. Wave propagation in a parallel plate transmission line driving a circular tube.

pulse then reverses to flow inward after the water section of the pulse has arrived at the edge of the tube. This produces a current null in the vacuum feed at a time when it has reached significant voltages. This could result in a failure of the magnetic insulation of the feed.

The solution we have chosen to this problem is to delay the arrival of the pulse traveling along the centerline of the generator, so that all portions of the tube see the electric wave arriving at the water/plastic interface simultaneously. This is accomplished by the use of the "transit time equalizer," shown schematically in Figure 12 and in the artist's rendering of Figure 13. We have used the NET-2 circuit code to model the performance of the coupler, which incorporates the transit time equalizer, by using a two-dimensional lumped-element circuit model shown schematically in Figure 14. As can be seen in the waveforms of Figure 13, the transit time equalizer significantly improves the azimuthal uniformity of the current, and eliminates the current null which could cause the failure of magnetic insulation. Independent calculations by Mandell and Wilson²² using a three-dimensional Maxwell equation solver agree well with these predictions.

Double-EAGLE Tube

The tube for the Double-EAGLE generator will be a vertical-axis tube with double-sided power flow. The upper half of the tube combines the currents from the upper halves of each of the two EAGLE modules; the lower tube combines the currents from the lower halves of the two EAGLE modules.

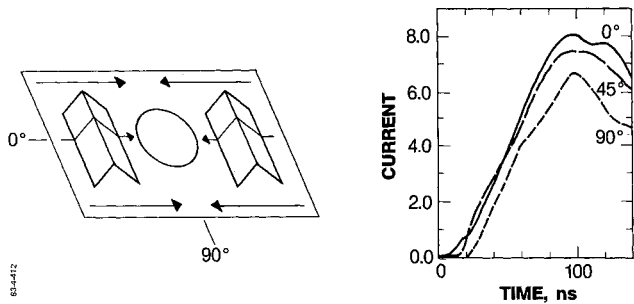

Figure 12. A schematic of the Double-EAGLE coupler region which includes the transit time equalizer. Raised elements in central portion of coupler delay the central portion of the wave with respect to the wings.

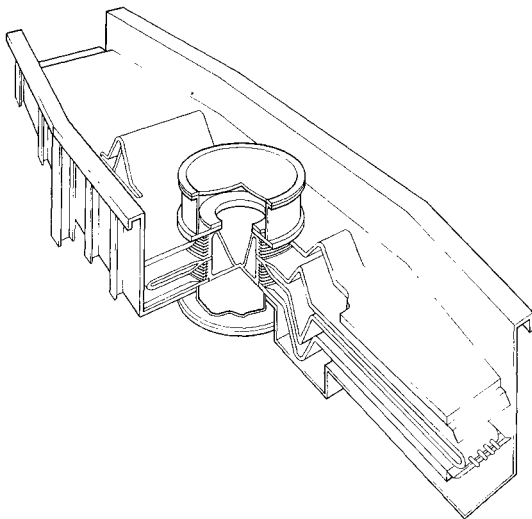

Figure 13. Artist's rendering of the Double-EAGLE coupler, which includes the transit time equalizer. The tube and vacuum feed region are at the center of the rendering.

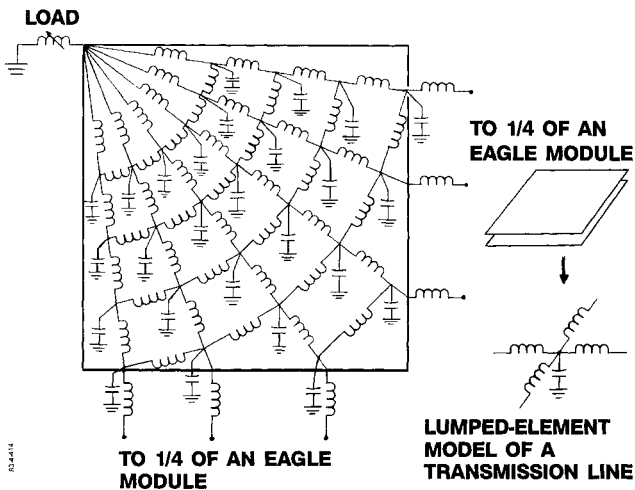

Figure 14. Two-dimensional lumped element circuit model for coupler region of ROULETTE-1.

When used with imploded plasma loads, the currents from the upper and lower feeds will be combined in a magnetically insulated convolute close to the load. The asymmetric feeds shown in Figure 15 give the maximum acceptance angle for X-rays from the source. To optimize the performance of the feed, we will field a rod anode (see Reference 23) to maximize pumping speed and to minimize damage to the feed in the case of a local arc.

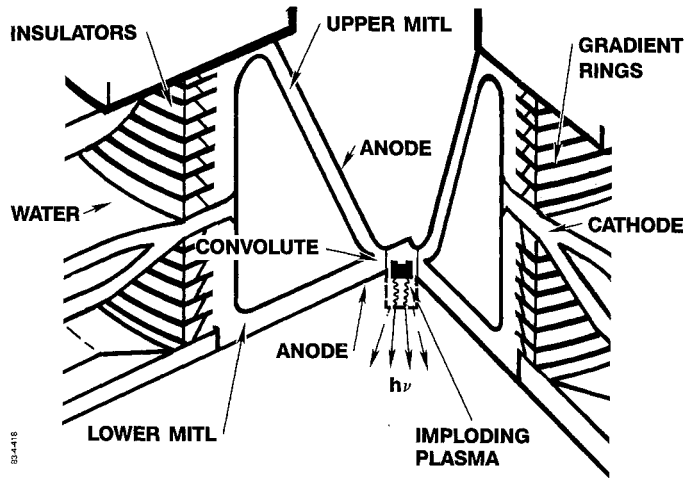

Figure 15. The Double-EAGLE tube and load region.

Double-EAGLE Construction Status

The construction of Double-EAGLE involves the fabrication of the second EAGLE module, the coupler which joins the two EAGLE modules, the vacuum tube, and the vacuum feed hardware. Also required was the extension of the existing EAGLE building to accommodate the two EAGLE modules, and other modifications of the facility to allow simulations testing on relatively large hardware.

The Double-EAGLE vacuum tube, vacuum feed, and post-hole convolute hardware are currently undergoing testing on PITHON. This is the actual hardware to be installed on Double-EAGLE. The lower feed²² has been tested separately from the upper feed, allowing the feeds to be operated at the full voltage and current levels they will see on Double-EAGLE. Additional tests are planned to obtain further operational performance and reliability data.

Facility construction, now complete, included expansion of the building to house the two modules; a large recessed test area to accommodate a large vacuum chamber for full system tests; and excavation of an oil containment berm for the oil storage and the second Marx generator.

Fabrication and assembly is ahead of schedule. Marx generator assembly has started and the outer tanks of the waterline are complete and ready for installation and alignment in the new facility. Construction of the screen room and operator area has been started and the computer-controlled command, control, and data acquisition system is being designed.

Summary

The data collected from the EAGLE testbed has been used extensively in the design of the

first of our low-impedance multi-module simulators, Double-EAGLE. The Double-EAGLE generator, designed to accommodate Megavolt Electron Bremsstrahlung and Plasma Radiation Sources for simulation testing, is presently being fabricated and will begin checkout testing in late 1983.

The modular approach to the generator has significantly reduced risks in the program. For example, the existing, thoroughly tested EAGLE module forms one of the two modules, and the second module is a direct copy of the existing EAGLE module.

The coupler which joins the two modules together has been extensively modeled with computer simulations. Furthermore, simulation predictions have been validated with experimental data from a half-scale mock-up of the coupler and cross-checked with three-dimensional computer solutions to Maxwell's equations²². To reduce risk in the tube and vacuum feed, the hardware is being checked on PITHON before final assembly into Double-EAGLE. Facility modifications for Double-EAGLE are complete and the fabrication of the hardware is going along on schedule. This 7 TW, 0.5 MJ, 75 ns (FWHM power) simulator will be available for radiation simulation testing in 1984.

Acknowledgements

The authors wish to acknowledge the support and encouragement of Mr. Jonathan Z. Farber and Major Hounq Soo of the Defense Nuclear Agency. Thanks go also to Charles Stallings and Al Toepfer for management and programmatic help. Willie Adams and Ken Klinck deserve special mention because of their many contributions to the operation and maintenance of EAGLE. Finally, we pay memorial homage to the late Jim Rhodes who was the mechanical designer of EAGLE, and most of Double-EAGLE.

REFERENCES AND NOTES

1. E. E. Conrad, Proceedings of the 3rd IEEE International Pulsed Power Conference, p. 1, IEEE 81CH1662-6 (1981).
2. G. B. Frazier, et al., ibid., p. 8.
3. J. Cortella, et al., ibid., p. 15.
4. S. A. Goldstein, et al., ibid., p. 47.
5. A. R. Miller, ibid., p. 200.
6. J. D. Shipman, Jr. "The Electrical Design of the NRL Gamble II, 100 Kilojoule, 50 Nanosecond, Water Dielectric Pulser Generator Used in Electron Beam Experiments," Proceedings of the 4th Symposium on Engineering Problems of Fusion Research, Washington, D.C. (April 20-23, 1971).
7. G. B. Frazier, Journal of Vacuum Science, Technical Volume, Volume 12, Number 6 (November/December 1975).
8. G. B. Frazier, Proceedings of NSWC 1976 Pulsed Power Workshop, Volume II, p. 342 (September 1976).
9. T. H. Martin, et al., Proceedings of the First International Topical Conference on Electron Beam Research and Technology, Volume 1, p. 450 (February 1976).
10. T. H. Martin, et al., Proceedings of the 1981 Particle Accelerator Conference, p. 3365 (March 11-13 1981).
11. G. B. Frazier, et al., IEEE Transactions on Nuclear Science, Volume NS-28, Number 3, p. 2717 (June 1981).
12. C. Stallings, K. Nielsen, and R. Schneider, Applied Physics Letters, Volume 29, Number 404 (1976).
13. C. Stallings, K. Childers, I. Roth, and R. Schneider, Applied Physics Letters, Volume 35, Number 7 (1979).
14. S. Wong, C. Gilman, P. Sincerny, and T. Young, "A Scaling Law For K-Line Radiation in the Imploding Argon Puff," 1982 IEEE International Conference on Plasma Science, Paper 2D3, IEEE 82CH1770-7 (1982).
15. G. B. Frazier, et al., Proceedings of the 4th International Topical Conference on High-Power Electron and Ion-Beam Research and Technology, Volume 2, p. 733 (June 29 - July 3, 1981).
16. L. J. Demeter, et al., IEEE Transactions on Nuclear Science, Volume NS-28, Number 3, p. 2931 (June 1981).
17. Steven R. Ashby, "An Adjustable Length Voltage Divider For Highly Stressed Transmission Lines," 4th IEEE Pulsed Power Conference (these proceedings), (1983).
18. R. A. Elbert and W. H. Lupton, Extrapolation of AWRE Breakdown Data, NRL Internal Report.
19. George B. Frazier and Steven R. Ashby, "Double-Bounce Switching," 4th IEEE Pulsed Power Conference (these proceedings), (1983).
20. J. C. Martin, unpublished notes (1977).
21. Steven C. Glidden, et al., "A 3 MV, Low-Jitter Transfer Capacitor Switching System," 4th IEEE Pulsed Power Conference (these proceedings), (1983).
22. Myron J. Mandell and Andrew Wilson, "Asymmetry Reduction in Double-EAGLE," ibid.
23. Peter Sincerny, et al., "Operating Specifications For A Rod Anode, Low Inductance, High Power MITL," ibid.