

CONTINUED DEVELOPMENT OF HIGHER ENERGY DENSITY,
HIGHER CURRENT RATED HOMOPOLAR GENERATORS AT CEM-UT

W. A. Walls and E. G. Estes
Center for Electromechanics
The University of Texas at Austin
Austin, TX 78712

Summary

The Center for Electromechanics at The University of Texas at Austin is continuing development of compact, high energy density homopolar generators for field-portable applications begun in 1979. In May 1982, the compact homopolar generator (HPG), which has a volumetric energy density of 17 MJ/m^3 , was assembled and successfully tested. Feasibility of the design depended on three novel features: inner brush mechanisms having small radial height; a means of removing one rotor half from the shaft and replacing it to permit assembly of the machine; and a magnetic shield for the rolling-element bearings.

To facilitate the development of still more compact HPGs, design work was begun in June 1982 on the Compact HPG Systems Tester. Built to test the systems and components necessary for machines storing up to 60 MJ/m^3 , the Systems Tester is one-half of a full-size counter-rotating HPG storing 2.5 MJ at 6900 rpm and generating 20 V . The Systems Tester, scheduled to be operational in June 1983, will incorporate face brushes and a stationary-shaft hydrostatic bearing. These experimental concepts allow changes in machine configuration in order to rotate a higher proportion of the magnetic circuit and to eliminate much of the stationary support structure. The Systems Tester will also provide an excellent test facility for future experiments on higher current density brushgear necessary for drawing higher currents from the reduced slip ring areas of smaller machines.

Introduction

The compact HPG is being developed for the U.S. Army Armament Research & Development Command (ARRADCOM) and the Defense Advanced Research Projects Agency (DARPA). Further increasing the volumetric energy density of the ARRADCOM/DARPA compact HPG can be accomplished by implementing several new features. Each new feature developed allows alteration of the generator configuration to produce varying energy density gains. Figure 1 shows that by splitting the field coil and

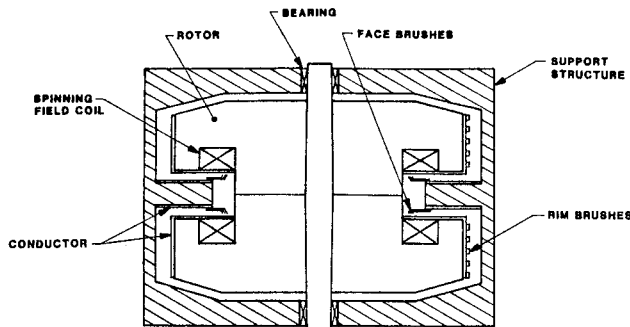

Fig. 1. Single-rotor HPG with face brushes and spinning coil - 10 MJ/m^3 energy density gain over ARRADCOM/DARPA machine

insetting the halves into the rotors so the coil spins and by replacing the inner ring brushes with face contact brushes, a greater fraction of the machine is storing inertial energy. An increase of 10 MJ/m^3 is

obtained with this design. Moving the bearings inside the rotor bore as shown in Fig. 2, the support structure becomes unnecessary, and the resulting machine

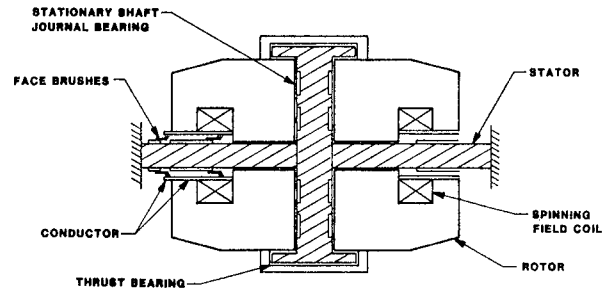

Fig. 2. Counter-rotating rotor HPG with stator face brush actuation, spinning coil, and stationary shaft bearings - 20 MJ/m^3 energy density gain over single-rotor machine

stores the same energy in a much smaller volume. These are stationary-shaft bearings and represent the single largest increase in compactness, 20 to 25 MJ/m^3 , of any of the new systems. Stationary-shaft bearings also allow counter-rotation of the two rotors and therefore torque compensation upon discharge, an important feature for some field-portable applications. In order to eliminate the stator completely, brush actuation must take place by moving one spinning rotor onto the face brushes mounted on the opposite rotor. Rotor actuation, shown in Fig. 3, represents a gain of an additional 15 MJ/m^3 , but is the most difficult of the new systems to develop.

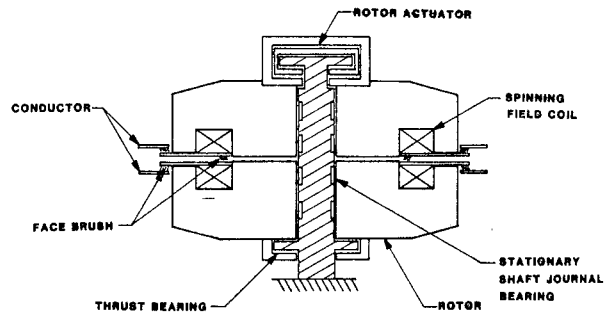

Fig. 3. Counter-rotating rotor HPG with face brushes, spinning coil, stationary shaft bearings, and rotor actuation - 15 MJ/m^3 energy density gain over face brush actuation machine

Note that Machine No. 2, which incorporates the two systems being studied on the Systems Tester, represents a gain of a factor of three in energy density over the present compact HPG.

ARRADCOM/DARPA Compact HPG Component Technology

Feasibility of the ARRADCOM/DARPA compact HPG configuration depended on the success of three subsystems designs:

Report Documentation Page

Form Approved
OMB No. 0704-0188

Public reporting burden for the collection of information is estimated to average 1 hour per response, including the time for reviewing instructions, searching existing data sources, gathering and maintaining the data needed, and completing and reviewing the collection of information. Send comments regarding this burden estimate or any other aspect of this collection of information, including suggestions for reducing this burden, to Washington Headquarters Services, Directorate for Information Operations and Reports, 1215 Jefferson Davis Highway, Suite 1204, Arlington VA 22202-4302. Respondents should be aware that notwithstanding any other provision of law, no person shall be subject to a penalty for failing to comply with a collection of information if it does not display a currently valid OMB control number.

1. REPORT DATE JUN 1983	2. REPORT TYPE N/A	3. DATES COVERED -	
4. TITLE AND SUBTITLE Continued Development Of Higher Energy Density, Higher Current Rated Homopolar Generators At CEM-UT		5a. CONTRACT NUMBER	
		5b. GRANT NUMBER	
		5c. PROGRAM ELEMENT NUMBER	
6. AUTHOR(S)		5d. PROJECT NUMBER	
		5e. TASK NUMBER	
		5f. WORK UNIT NUMBER	
7. PERFORMING ORGANIZATION NAME(S) AND ADDRESS(ES) Center for Electromechanics The University of Texas at Austin Austin, TX 78712		8. PERFORMING ORGANIZATION REPORT NUMBER	
9. SPONSORING/MONITORING AGENCY NAME(S) AND ADDRESS(ES)		10. SPONSOR/MONITOR'S ACRONYM(S)	
		11. SPONSOR/MONITOR'S REPORT NUMBER(S)	
12. DISTRIBUTION/AVAILABILITY STATEMENT Approved for public release, distribution unlimited			
13. SUPPLEMENTARY NOTES See also ADM002371. 2013 IEEE Pulsed Power Conference, Digest of Technical Papers 1976-2013, and Abstracts of the 2013 IEEE International Conference on Plasma Science. Held in San Francisco, CA on 16-21 June 2013. U.S. Government or Federal Purpose Rights License.			
14. ABSTRACT			
15. SUBJECT TERMS			
16. SECURITY CLASSIFICATION OF:			17. LIMITATION OF ABSTRACT SAR
a. REPORT unclassified	b. ABSTRACT unclassified	c. THIS PAGE unclassified	
			18. NUMBER OF PAGES 4
			19a. NAME OF RESPONSIBLE PERSON

- inner brush mechanisms having small radial height to fit under the field coil without greatly reducing rotor magnetic area and machine voltage;
- a hydraulic technique of installing and removing one rotor half from the shaft as required by machine configuration for assembly; and
- a magnetic shield to direct any leakage fields from the magnetic circuit away from the rolling-element bearings.

Each of these systems was proven during initial testing of the HPG in May 1982, as the machine met or exceeded all design goals.¹

Low Radial Height Brush Mechanisms

Inner brush mechanisms of about 1 in. in radial height were required to fit under the field coil and still allow ample magnetic area in the rotor. The heart of the resulting trailing strap design (Fig. 4) is the molded elastomer diaphragm actuators. These pieces, designed at CEM-UT and manufactured by the Randolph Austin co., are neoprene molded around a stainless steel core and trapped on top by an epoxy-impregnated Fiberglas dovetail plate which also serves to mount the actuator. Manifolding is accomplished at the outer radius of the stator inside the shrunk fit aluminum ring and is brought to the actuator by an O-ring sealed steel tube. Extensive testing of the actuator proved that it could provide the required downforce and could expand far enough to account for brush wear equivalent to more than 1,000 machine discharges.

Another important component developed for the brush mechanisms was the self-lifting laminated brush strap. Because the brush mechanisms themselves serve as making switches, it is very important that the brushes be lifted clear of the rotor to prevent arcing or premature discharge. Having the strap sufficiently flexible to minimize downforce requirements on the actuator and compliance enough to lift itself clear, a composite laminated design was employed. Each strap consists of three layers, two of annealed ETP 110 copper and one of dispersion strengthened copper. Collectively, the two ETP 110 straps can be deflected to yielding with 1.51 lbf. The dispersion strengthened strap, which has 90 percent conductivity and does not anneal during the silver brazing operation, yields after 0.037 in. of travel and requires 3.23 lbf. This deflection force also represents the restoring force which lifts the strap when released, so the dispersion strengthened strap has enough restoring force to yield both ETP 110 straps in lifting them clear of the rotor.

Although not dictated by machine geometry, brush mechanisms of low radial height were also employed for the two outer brush sets. Shorter actuators, fed with air pressure from the end, were developed for these mechanisms. In principle, the outer actuators are similar to the inner ones. Molded elastomer around a phosphor bronze core that serves as the clamping nut for the straps. Without the Fiberglas dovetail plate

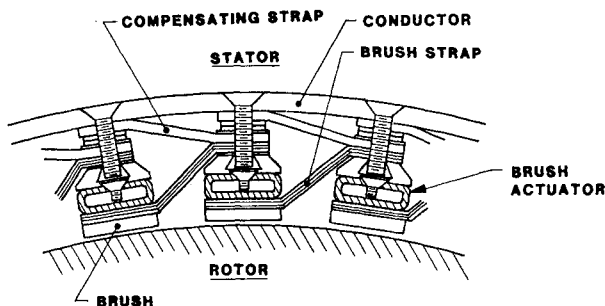

Fig. 4. Section through inner brush actuation mechanism

to clamp and hold the rubber, a molded cap was required to limit expansion except in the direction desired. The cap and actuator are shown in Fig. 5.

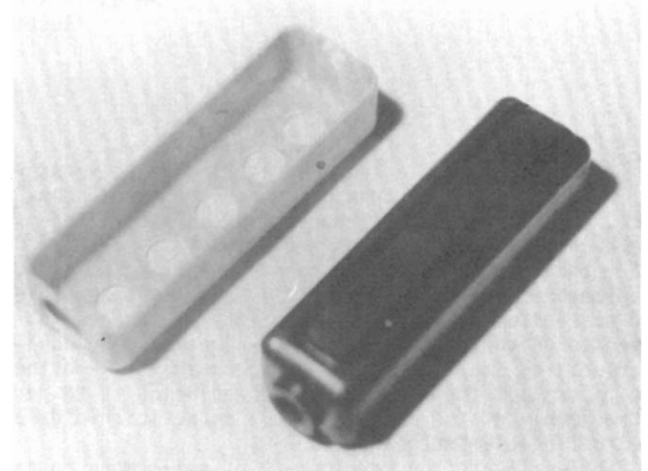

Fig. 5. Molded brush actuator diaphragm and molded cap

Rotor/Shaft Hydraulic Assembly

The design selected for the ARRADCOM/DARPA HPG also dictates splitting the rotor into halves in order to fit it around the stator, field coils and inner brush mechanisms. One rotor half must also be removable for required maintenance and servicing of these components. An interference fit between the shaft and the rotor is required to maintain contact as the rotor bore expands due to spin stresses, however. This interference is normally accomplished with a thermal shrink fit, a permanent assembly technique. In order to make one rotor half removable, a hydraulic assembly technique was refined and proven. Figure 6 shows a schematic drawing of the system. The hydraulic-fit rotor half is positioned on the shaft with high pressure seals at each

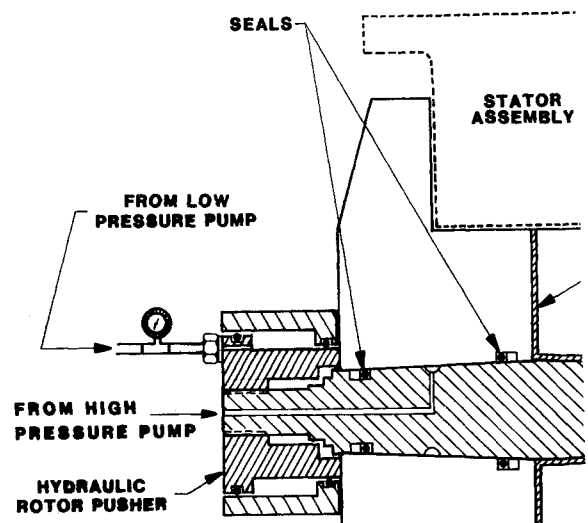

Fig. 6. Section through hydraulic rotor assembly mechanism

end to prevent leakage. A manual high pressure pump is used to pressurize the interface to 45,000 psi and expand the rotor bore sufficiently to allow the rotor to be pushed onto the shaft. Removal of the rotor is carried out by pressurizing the bore and hydraulically catching it as it is forced off the tapered shaft.

Magnetic Bearing Shields

Designed to be a lightweight, field-portable machine, the ADCHPG employs oil mist-lubricated rolling-element bearings because they require fewer auxiliaries and inherently cost less than comparable fluid film bearings. A major drawback to using rolling-element bearings is the possibility of circulating and eddy currents set up by stray magnetic fields causing arcing and pitting of the bearing surfaces. To address this problem, a magnetic shielding and shunting system was devised using a nonferromagnetic housing and ferromagnetic steel sleeves and plates to direct the stray fields away from the bearings. Aluminum oxide ceramic is also employed to insulate the bearings from the housing, thus preventing long-range circulating currents between the thrust and journal bearings.

Systems Tester

In pursuit of even higher energy density machines, CEM-UT has continuing funding from ARRADCOM/DARPA to test the systems required to alter the compact HPG configuration to rotate a greater fraction of the magnetic circuit and eliminate much of the machine support structure. The compact HPG systems tester, shown in Fig. 7, will provide full-scale experiments of

stationary-shaft bearings and the associated machine dynamics. Feasibility of running face brushes in an HPG will also be examined. Once the preliminary development of these components is complete, the systems tester will provide an excellent facility for future work on higher current density brushes, rotor actuators, and self-excited spinning-coil machines.

The 3,000-psi hydrostatic stationary shaft and thrust bearings have ample load capacity and stiffness to handle a 2-MA discharge. The brush gear to be implemented is designed mechanically to sustain a 1-MA discharge. If higher current shots are necessary, the mechanisms can be altered to handle the higher associated forces.

Brush Mechanisms

Unlike any machine built at CEM-UT before, the systems tester will run its brushes on the rotor face rather than on the rotor periphery. Several problems are inherent with running brushes in this mode. The brush tends to wear unevenly because of the variation of slip speed with radius, which can cause the brush to slowly lose its ability to track properly. Second, because of their location, face brushes are more likely to see the externally-applied magnetic field, which causes high $J \times B$ forces as well as circulating currents

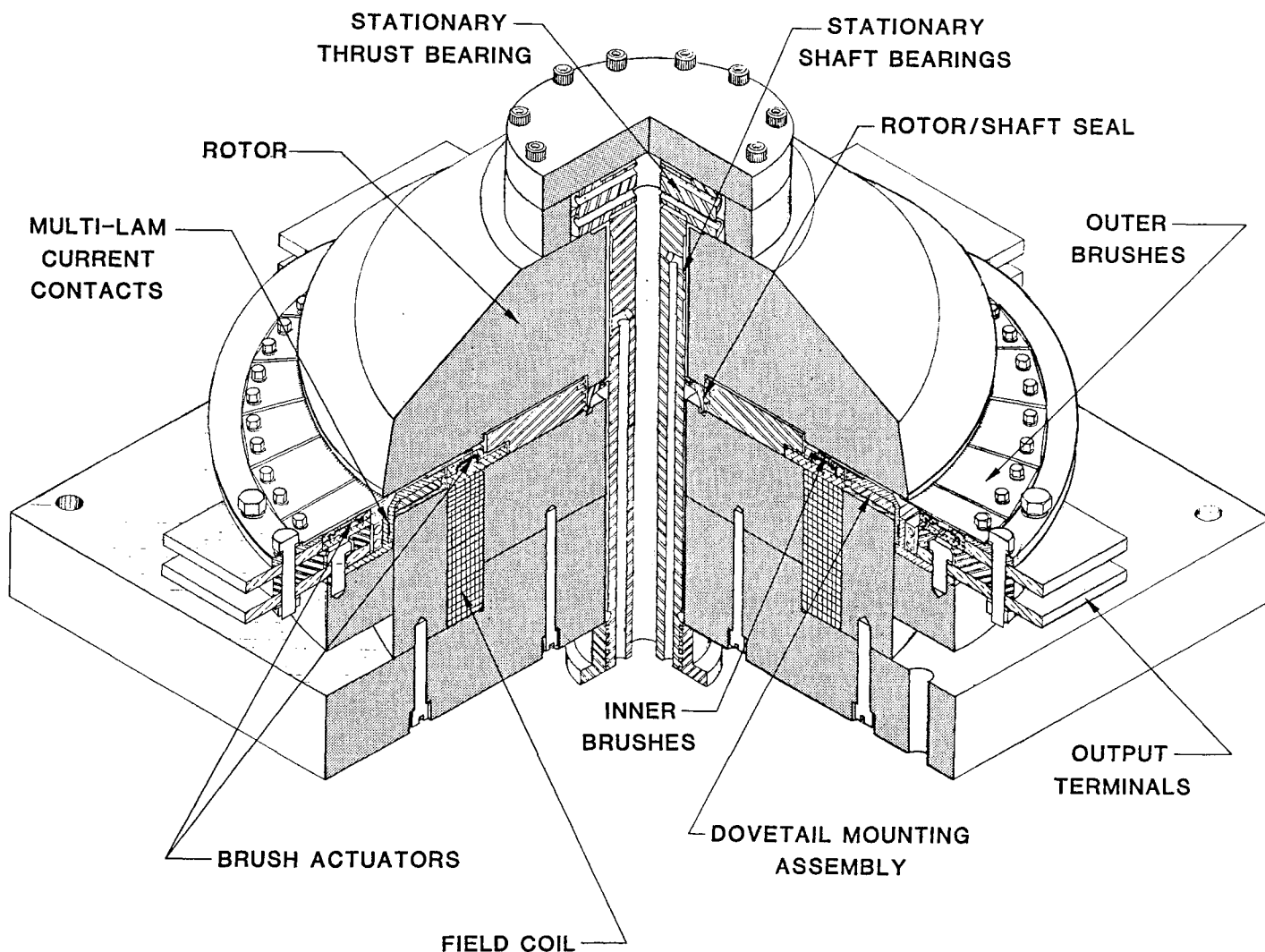

Fig. 7. Systems tester

in the straps. Also, current repulsion force compensation is difficult if the mechanism is to be axially compact.

Sintered copper-graphite (CM1S) was chosen for the Systems Tester inner brushes because it has performed reliably on other CEM-UT generators in the past. Although never run in the face mode, CM1S brushes are the first choice to minimize maintenance on the less accessible inner brush mechanism. The easily replaceable outer brushes will be experimental and the primary source of advanced brush design data. Higher slip speed at the increased radius and better visibility also make this choice a wise one.

Actuation of both mechanisms will be accomplished with an inflatable continuous ring elastomer diaphragm actuator designed at CEM-UT. Shown in Fig. 5, the actuator must provide sufficient force to deflect the laminated copper strap, to load the brush against the rotor for proper tracking, and to overcome the force generated by the opposing current paths in the rotor and straps. In total, 5,600 lb_f of actuator force is required. At 200 psi and nominal travel, the inner actuator will provide approximately 6,000 lb_f, and all tests indicate that the diaphragm can be inflated to even higher pressures.

Development of copper-finger face brushes at CEM-UT began in 1979.² Initial experiments were run at slow slip speeds on a copper surface while being pulsed with the CEM-UT 10-MJ HPG. At sliding speeds of 15 mm/s, brush finger current densities of 570 MA/m² (367 kA/in.²) were obtained for pulse durations of 0.3 s. Current densities of 78.6 MA/m² (50.7 kA/in.²) on the collector surface were recorded using a light machine oil lubrication of the interface. With these encouraging results, high-speed tests were performed in 1982. Single rows of eight copper fingers (1.57 x 3.2 mm) were run on both steel and copper slip surfaces at sliding speeds up to 230 m/s. Current pulses were drawn from a 12-V automobile battery, and switching was accomplished by the brushes. Copper fingers on steel with oil lubrication showed much promise, as voltage drops of 0.2 V were recorded at 150 m/s sliding speeds and 31 MA/m² (20 kA/in.²) finger current densities. These data are a significant improvement over CM1S brushes, which have a characteristic interface voltage drop of 0.5 V and are generally run at current densities of 15.5 MA/m² (10 kA/in.²). The copper finger brushes, however, had a very limited lifetime at these speeds and current densities, generally lasting 50 to 100 discharges. Arcing under the contacts was the primary reason for the usually high wear rates, and should not occur as severely in an actual machine, where current can commutate to another brush rather than arc. Because of difficulty in simulating actual generator brush gear operating conditions, further testing will proceed when the systems tester is complete.

Stationary-Shaft Bearings

Volumetric energy density gains of 20 to 25 MJ/m³ can be realized if stationary-shaft bearings are successfully developed. Placement of the bearing inside the rotor bore makes the aluminum structure of the HPG unnecessary and allows separation of the rotor halves for counter-rotation and torque compensation. In a normal rotor/shaft configuration, the growth is taken in an interference fit that becomes less tight at speed, but maintains a nominal contact pressure. Using a stationary-shaft bearing means that the growth must be absorbed in greater bearing clearance at speed. The two bearings have been optimized separately, with the lower bearing having wider lands to cut leakage flow at the increased clearance. Stiffness requirements dictate that the bearing be supplied with 3,000-psi oil introduced by four 3/8-in. diameter holes drilled through the entire length of the shaft. Each hole supplies one pocket in each journal bearing and two

pockets in the stationary thrust bearing mounted on the top of the shaft. The return sump for all bearings is a 1-1/8-in. diameter hole running down the center of the shaft. Sealing is accomplished at the base of the rotor by a carbon-graphite Bal-Seal for static and low-speed duty and a dynamic back-wind seal for high-speed operation when the rotor growth pulls the Bal-Seal away from the shaft. Figure 8 shows the machined bearing pockets in the stationary shaft.

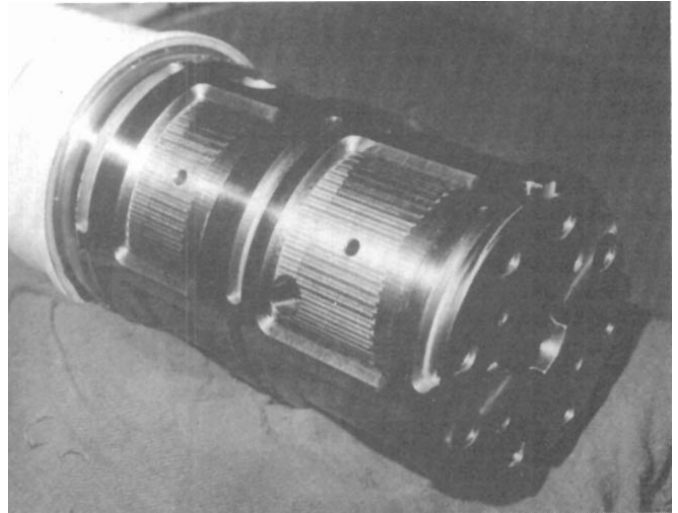

Fig. 8. Stationary-shaft bearing pockets

Both the journal bearings and the thrust bearing will be instrumented to measure transient and static pocket pressure. These data will be used to determine characteristic bearing orbits and other transient motions expected during the generator discharge sequence.

Future Research

One of the easiest ways to increase HPG energy density is to spin the rotor faster. Energy stored increases as the square of the angular velocity. At present, brushes are limited to slip speeds of about 220 m/s due to tracking problems, increased frictional heating, and wear. Also, the counter-rotating stationary-shaft bearing machine has greater problems with rotor bore growth above 200 m/s. To address these and other obstacles, such as rotor actuation and spinning self-excited field coils, the system tester is scheduled for extensive experiments and rebuilding during the next year. Brush experiments planned include copper-finger brushes and composite CM1S/copper brushes, as well as passively and actively cooled brushes. A new stationary-shaft orifice-compensated hydrostatic bearing that adjusts orifice resistance with speed to allow operation to higher speeds is already being designed. As these experiments are completed and the results evaluated, the design of the second-generation compact HPG should begin in 1984.

1. Gully, J. H., "Assembly and Testing of a Compact, Lightweight Pulsed Homopolar Generator Power Supply," Proc. IEEE Pulsed Power Conference, 4th, Albuquerque, NM, June 6-8, 1983.
2. Marshall, R. A., "High Current and High Current Density Pulse Tests of Brushes and Collectors for Homopolar Energy Stores," IEEE Components, Hybrids, and Manufacturing Technology, Vol. CHMT-4, n. 1, Mar 1981, 127-131.